

1887-8.

NEW SOUTH WALES.

VOTES

AND

PROCEEDINGS

OF THE

LEGISLATIVE ASSEMBLY

DURING THE SESSION

OF

1887-8,

WITH THE VARIOUS DOCUMENTS CONNECTED THEREWITH.

IN TEN VOLUMES.

VOL. IX.

SYDNEY :

CHARLES POTTER, GOVERNMENT PRINTER, PHILLIP-STREET.

1888.

1887-8.

---

LEGISLATIVE ASSEMBLY.  
NEW SOUTH WALES.

---

VOTES AND PROCEEDINGS.

SESSION 1887-8.

IN TEN VOLUMES.

---

TABLE OF CONTENTS.

---

VOL. IX.

Title Page.

Table of Contents.

Index.

PATENTS—

Letters of Registrations of Inventions for 1883 ... .. . 1

---



1887-8.

LEGISLATIVE ASSEMBLY.  
NEW SOUTH WALES.

INDEX

TO THE  
VOTES AND PROCEEDINGS  
AND  
PAPERS LAID UPON THE TABLE  
DURING THE SESSION  
OF  
1887-8.

Opened 20 September, 1887, prorogued 24 July, 1888.

REFERENCES TO THE VOTES AND PROCEEDINGS, VOL. I—13TH PARLIAMENT—SESSION, 1887-8.	PAPERS	
	VOL.	PAGE.
<b>A</b>		
ABATTOIRS, GLEBE ISLAND :— Petition from Municipal District Council of Leichhardt for abolition of, presented, 16 .....	8	669
ABBOTT, JOSEPH, ESQ. :— Return of Writ for Newtown, certifying to return of, reported, sworn, 249.		
ABBOTT, MR. J. P., M.P. :— Motion made ( <i>Mr. Abbott</i> ) to remove name from Select Committee on "Mineral Conditional Purchase, Parish of Metz," 462. Name of Sir Henry Parkes substituted for, on Committee on "Teralba Coal-mining Reserve," 585.		
ABBOTT, MR. T. K., STIPENDIARY MAGISTRATE— Return showing number and nature of complaints against Stipendiary Magistrates, laid on Table (not printed), 378.		
ABORIGINES OF THE COLONY :— Motion made ( <i>Mr. Dowel</i> ) for Committee of the Whole for Address to Governor for £10,000 for supplying rations, clothing, and shelter to, and withdrawn, 129. Annual Report of Board for Protection of, for 1887, laid on Table, 475 .....	4	687
ABSENCE (See "LEAVE OF ABSENCE").		
ACCIDENT (See "RAILWAYS").		
ACCOMPLICES EVIDENCE AMENDING BILL :— Motion made ( <i>Mr. Hassall</i> ) for Committee of the Whole, 215 ; Order of the Day postponed, 253, 325, 508 ; discharged, 608.		
ACCOUNTS (See "FINANCE").		
ACQUISITION OF LAND (See "PUBLIC WORKS BILL").		
ADDISON, MR., STIPENDIARY MAGISTRATE :— Motion made ( <i>Mr. O'Sullivan</i> ) for a Select Committee to inquire into charges of misconduct alleged against, by a meeting of licensed cabmen and drivers, and debate adjourned, 130 ; Order of the Day postponed, 147 ; debate resumed and motion negatived, 234. Return of cases heard at Water Police Court by, on 17th November, 1887, laid on Table (not printed), 174. Petition from C. Prince, Chairman of meeting of licensed drivers, expressing dissatisfaction with, when adjudicating in cases in which they were concerned, and praying the appointment of a Select Committee, 185 .....	2	625
Return showing number and nature of complaints against Stipendiary Magistrates, laid on Table not printed, 378.		
ADDITIONAL SITTING DAYS (See also "ASSEMBLY") :— Friday made a sitting day, meet at 3 o'clock, and Government business to take precedence of general business after 7 o'clock, p.m., 103 ; rescinded, 325. Monday made a sitting day, meet at 3 o'clock, and Government business to take precedence, 585.		

REFERENCES TO THE VOTES AND PROCEEDINGS, VOL. I—13TH PARLIAMENT—SESSION, 1887-8.	PAPERS.	
	VOL.	PAGE.
<b>A</b>		
ADDITIONAL STANDING ORDER (See "STANDING ORDERS").		
ADDRESS :—		
IN REPLY TO GOVERNOR'S OPENING SPEECH :—		
Brought up, 3; motion made ( <i>Mr. Carruthers</i> ) for adoption of, 4; presented, and His Excellency's answer reported, 5.		
CONGRATULATORY, TO HER MAJESTY THE QUEEN ON THE COMPLETION OF THE JUBILEE YEAR OF HER REIGN :—		
Mr. Speaker informed the House of the receipt of telegram conveying the special thanks of Her Majesty for the Address, 2.		
CONDOLENCE TO HER MAJESTY THE QUEEN ON THE DEATH OF THE EMPEROR OF GERMANY :—		
Motion made ( <i>Sir Henry Parkes</i> ) for, 530.		
Letter from His Excellency the Governor conveying reply of Secretary of State to, 556		
CONDOLENCE TO HER IMPERIAL MAJESTY THE EMPRESS VICTORIA :—		
Motion made ( <i>Sir Henry Parkes</i> ) for, 530.		
ADDRESSES AND ORDERS :—		
Motion made ( <i>Mr. O'Sullivan</i> ) for a return showing what Resolutions for the production of departmental papers, returns, correspondence, &c., have not been attended to, 118; Returns ( <i>in part</i> ) to Order, laid on Table, 191, 223, 257	1	839, 841, 843
Motion made ( <i>Mr. Wall</i> ) for a return showing the number of Orders made for production of papers and returns since 1st January, 1886, which have not been complied with, 210; Returns ( <i>in part</i> ) to Order laid on Table, 257, 334	1	845, 847
Alphabetical Registers of	1	821
ADELAIDE JUBILEE INTERNATIONAL EXHIBITION :—		
Motion made ( <i>Mr. Neild</i> ) for adjournment of the House in reference to, 543.		
EXECUTIVE COMMISSIONER FOR :—		
Motion made ( <i>Mr. Hassall</i> ) for a return showing the amount paid by the Treasurer to Mr. J. C. Neild, M.P., since his appointment as, 30; Return to Order, laid on Table, 75		
NEW SOUTH WALES COMMISSION :—		
Report of the President, 565		
ADJOURNMENT :—		
SPECIAL, 1, 128, 216, 246, 282, 314, 353 ( <i>Easter</i> ), 456, 467 ( <i>Queen's Birthday</i> ).		
OF HOUSE :—		
Before commencement of business, 203, 465.		
For want of Quorum, before commencement of business, 297.		
Do after commencement of business, 108, 321, 599.		
Motion made for, and passed, 12, 17, 30, 36, 53, 65, 77, 82, 85, 91, 99, 119, 123, 137, 140, 203, 211, 222, 248, 268, 288, 304, 309, 323, 329, 354, 357, 362, 366, 374, 381, 386, 391, 404, 410, 422, 426, 434, 437, 446, 452, 464, 465, 476, 481, 487, 494, 496, 502, 509, 515, 520, 526, 538, 544, 549, 554, 561, 567, 580, 587, 603, 610, 615, 628.		
Motion made for, and withdrawn, 53, 246, 370, 587.		
Motion made for, and House counted out, 108.		
Motion made for, under Additional Standing Order No. 1, on the subjects stated below, and negatived,—		
Publication of Book called "The Introduction of Parliamentary Government in New South Wales," 30.		
Increased prevalence of gambling in shops occupied by Chinese, 35.		
Payment of £16,000 for Evans's Truck Patent, and withdrawn, 53.		
Answer given to a question (Major Parrott's Military Report), 64.		
Replies in reference to paragraphs in newspapers commenting on a compromise alleged therein to have been recently effected by Sir Henry Parkes with his creditors, some of whom are his colleagues in the present Government, 70.		
Gross misrepresentation of Members of the Opposition by the Minister of Public Instruction at Tuena, 88.		
Language used by Minister of Public Instruction in referring to the Opposition, 103.		
Unsatisfactory answer of Minister for Mines <i>re</i> deputation from Newcastle <i>re</i> Sand-drift, 119.		
Statement of the Colonial Secretary as to dealing with measures before Parliament and other matters relating to the government of the Colony, 123.		
Neglect of Lands Department in not providing roads to give access to railway stations, towns, and to main roads, 135.		
Condition of Public Business, 140.		
Facts disclosed in papers laid on Table in case <i>Regina v. Pruett</i> , 151.		
Action taken by the Police in the prosecution of persons for selling the paper known as <i>The Sunday Times</i> , 186.		
Safety of Harbour Steamers and the laws for the management of steamers which are declared by the Chief Justice to be monstrous, 192.		
Answer given by Secretary for Public Works on the question of survey of railway route to Inverell, 197.		
Statements of Examiner of Coal-fields, in papers laid upon the Table, and reflecting upon Commissioners Report, <i>re</i> Bulli Explosion, 200.		
Unworthy appointments to the Commission of the Peace, made by the Ministry now in power, 208.		
Non-production of certain Schedules, 215.		
Arrest of Members, 224.		
Report on the prevalence of leprosy at Honolulu, and other matters affecting public health, 228.		
Proposed expenditure on the State House, and withdrawn, 246.		
Papers laid on Table relating to purchase of a "Gulcher" and plant by Telegraph Department, &c., 246.		
Unsatisfactory administration of the Land Laws by the Minister for Lands, 263.		
Decision of the Privy Council in <i>Tearle v. Edols</i> , and the reservation of forfeited selections within the geographical boundaries of the pastoral holdings, 287.		
Condition of railway labourers on the Blayney and Cowra line, and matters of public importance connected therewith, 325.		
Removal of a large number of men from railway workshops and sheds at Bathurst, and to the fact that the answers given in this Chamber by the Minister were inaccurate and misleading, 328.		
Attack made in an article in the <i>Sydney Morning Herald</i> on the Honorable Member for Northumberland, Mr. Melville, 335.		
Action of the Home Government in reference to the Divorce Extension Bill, 342.		
Certain parties, M's.L.A., and others occupying a number of compartments in railway carriages, where only one or two persons occupy the compartments without the number of tickets, 378.		
Statements made in the public Press reflecting upon the Administration of Justice, 429.		

REFERENCES TO THE VOTES AND PROCEEDINGS, VOL. I—13TH PARLIAMENT—SESSION, 1887-8.	PAPERS:	
	VOL.	PAGE.
<b>A</b>		
<b>ADJOURNMENT—(continued) :—</b>		
<b>OF HOUSE—(continued) :—</b>		
Motion made for, and negatived— <i>continued</i> .		
Decision of the Supreme Court, and the intention of the Government in regard thereto, in the matter of the illegal detention of certain Chinese, 463.		
Mineral Conditional Purchases made by the Lane Family and Mr. Withers on the Teralba Coal-mining Reserve, 493.		
Railway Policy of the Government, 513.		
Remission of £900 of a fine £1,000 inflicted on the Captain of the S.S. "Chelydra" for carrying more than the legal number of Chinese, 525.		
Adelaide Jubilee International Exhibition, 543.		
Statement of Treasurer in reference to state of the Public Accounts, 561.		
Necessity of immediate legislation in reference to the fencing clauses of the existing Land Law, 565.		
Refund of abatements in rents in cases where Crown Lessees have appealed and the rent has been reduced, 586.		
Certain actions of the present Government; and Point of Order raised that "a definite matter" of urgent public importance had not been stated in the notice, and Mr. Speaker pointed out that, by a previous decision of the House, he had been relieved of the responsibility of deciding the point which should have been taken before the motion was stated, 635.		
<b>OF DEBATE :—</b>		
Motion made for, and passed, 35-6, 77, 99, 104, 115, 130, 140, 145, 225, 259, 296, 309, 315, 326, 335, 338, 525, 547.		
Motion made for, and passed, to take precedence, 169, 181, 208, 210, 216.		
Do and negatived, 4, 186, 221, 253.		
<b>ADMINISTRATION OF JUSTICE (See also "ATTORNEY-GENERAL") :—</b>		
<b>EMERY v. BARCLAY :—</b>		
Motion made ( <i>Mr. Martin</i> ) for all papers and plans retained at the Supreme Court, 352.		
<b>REGINA v. PRUEN :—</b>		
Motion made ( <i>Mr. O'Mara</i> ) for all depositions, letters, &c., relating to case of, trial at Quarter Sessions, Bathurst, 30; Return to Address laid on Table, 88	2	681
Motion made that this House do now adjourn to call attention to fact disclosed in Papers, and negatived, 151.		
<b>DISTRICT COURT BAILIFFS :—</b>		
Motion made ( <i>Mr. Gould</i> ) for a return showing names, and amount of fees received by each, distinguishing the several services for which the fees were paid, during 1886 and to 30th June, 1887, 48; Return to Order laid on Table, 492	2	635
<b>PENAL ADMINISTRATION :—</b>		
Report respecting proposed changes in, laid on Table, 52	4	1213
<b>JUVENILE OFFENDERS :—</b>		
Motion made ( <i>Mr. Thompson</i> ) for return in continuation of a previous one, up to 30th June, 1887, 97; Return to Order laid on Table, 165	2	707
<b>ROBERT COYLE :—</b>		
Motion made ( <i>Mr. Walker</i> ) for a Select Committee to inquire into the treatment of, whilst a prisoner in Berrima and other gaols, and debate interrupted by Government Business, 123; Order of the Day postponed, 131; Order of the Day discharged 252.		
<b>CASE OF W. A. HOPKINS :—</b>		
Motion made ( <i>Mr. Hassall</i> ) for all papers in connection with, who was sentenced to six weeks imprisonment for assault, 128; Return to Order laid on Table (not printed), 181.		
<b>MR. ADDISON, STIPENDIARY MAGISTRATE :—</b>		
Motion made ( <i>Mr. O'Sullivan</i> ) for a Select Committee to inquire into charges of misconduct alleged against, by a meeting of licensed cabmen and drivers, and debate adjourned, 130; Order of the Day, postponed, 147; debate resumed and motion negatived, 234.		
Return of cases heard at the Water Police Court by, on 17th November, 1887, laid on Table (not printed), 174.		
Petition from C. Prince, Chairman of meeting of licensed drivers expressing dissatisfaction with, when adjudicating in cases in which they were concerned, and praying the appointment of a Select Committee, 185	2	625
<b>THE REV. H. H. BRITTEN, OF RYDE :—</b>		
Motion made ( <i>Mr. J. S. Farnell</i> ) for all documents, depositions, &c., in the case of alleged arson against, and any letters respecting the conduct of Mr. Manning, Coroner, at Ryde, 136; Return to Address laid on Table, 326	2	639
Motion made ( <i>Mr. Frank Farnell</i> ) for letters written to the Minister of Justice by Mr. J. E. Manning, on 2nd December, 1886, and 20th January, 1887, in reference to the alleged arson case at Ryde, 344; Return to Address laid on Table, 415	2	679
<b>LATE ACTING POLICE MAGISTRATE AT COROWA :—</b>		
Returns to Order ( <i>Second Session</i> , 1887), laid on Table (not printed), 144, 389; ordered to be printed, 454	2	631
<b>SUPREME COURT :—</b>		
Rules of, laid on Table, 257, 267, 635	2	709, 711, 727
<b>CLAIM OF CHARLES STEVENS :—</b>		
Report of Select Committee adopted, 268.		
<b>JUDGE DOCKER :—</b>		
Motion made ( <i>Mr. J. P. Abbott</i> ) for papers, &c., relating to claim for travelling expenses by, 287; Return to Address laid on Table, 451	2	617
<b>SHEPHERD v. LEONARD :—</b>		
Motion made ( <i>Mr. Dawson</i> ) for papers in case of, 303; Return to Order laid on Table (not printed), 341.		
<b>CASE AGAINST MR. T. W. CHAMBERS, AT TIBOOBURRA :—</b>		
Motion made ( <i>Mr. J. P. Abbott</i> ) for papers relative to, 320. Return to Address laid on Table (not printed), 524.		
<b>CASE OF QUEEN v. BOWLER :—</b>		
Motion made ( <i>Mr. Stokes</i> ) for address to the Governor for papers, &c., 403; Return to Address laid on Table, 429	2	703
<b>PRISONS :—</b>		
Annual Report on, for 1887, laid on Table, 420	4	1223
<b>POLICE MAGISTRATE FOR PARRAMATTA :—</b>		
Return to Order ( <i>Session 1885</i> ) laid on Table, 425	2	627
Motion made ( <i>Mr. Frank Farnell</i> ) for all papers in reference to appointment of, 429; Returns to Addresses laid on Table, 451, 635	2	629
Motion made ( <i>Mr. Vaughn</i> ) for adjournment of the House in order to call attention to statements made in the public Press reflecting on, 429.		

REFERENCES TO THE VOTES AND PROCEEDINGS, VOL. I—13TH PARLIAMENT—SESSION, 1887-8.	PAPERS.	
	VOL.	PAGE.
<b>A</b>		
ADMINISTRATION OF JUSTICE—(continued):—		
COMMISSIONS TO PROSECUTE FOR THE CROWN:—		
Motion made ( <i>Mr. McElhone</i> ) for return showing particulars of, 437; Return to Order laid on Table, 462.....	2	623
PUBLIC INSTRUCTION ACT:—		
Information respecting prosecutions under the compulsory clause laid on Table, 437.....	4	501
CROWN v. WALLESEND COAL COMPANY:—		
Correspondence respecting laid on Table, 524.....	8	259
DISTRICT COURTS ACT OF 1858:—		
Annual returns under 103 section, laid on Table, 524.....	2	735
MAXWELL ANNE, ASSAULT WITH INTENT ON:—		
Motion made ( <i>Mr. Buchanan</i> ) for Address to Governor for copies of all papers in reference to case of, tried at Lismore Quarter Sessions, 560; Return to Address laid on Table, 635.....	2	689
REGINA v. CHRISTENSON:—		
Motion made ( <i>Mr. Kelly</i> ) for Address for papers in case of, 619.		
ADMINISTRATION OF LAND LAWS (See "CROWN LANDS").		
"AFGHAN S.S.":—		
Return respecting Chinese passengers by, laid on Table, 454.....	2	211
AGRICULTURAL COLLEGE:—		
Motion made ( <i>Mr. Kethel</i> ) for address to the Governor for establishment of, and by leave withdrawn, 370.		
AGRICULTURAL COLLEGE AND EXPERIMENTAL FARMS BILL:—		
Motion made ( <i>Sir Henry Parkes</i> ) for Committee of the Whole, 416.		
AGRICULTURAL PRODUCTS:—		
IMPORT DUTIES:—		
Motion made ( <i>Mr. Copeland</i> ) that it is desirable to encourage the agricultural interests, by imposing import duties on grain, pulse, beans, peas, hay, barley, oats, chaff, flour, meal, bran, pollard, sharps, and potatoes, and debate adjourned, 169; negatived, 233.		
Petition presented ( <i>Mr. Copeland</i> ) from residents of New England representing that the farming industry is in a deplorable condition, and praying the House to grant relief &c., and read by the clerk, 492.....	3	873
Petition presented ( <i>Mr. Copeland</i> ) from farmers, Inverell District in favour of a specific duty on grain, 492.....	3	871
Motion made ( <i>Mr. Copeland</i> ) for moderate import duties on agricultural productions grown in the Colony on all articles that can be manufactured in the Colony, and the question not being put at 7 o'clock, Government business takes precedence, 493; Order of the Day postponed, 506; Debate resumed and question negatived, 509.		
Petition presented ( <i>Mr. Crouch</i> ) from Casino Political League in favour of, and praying the House to pass <i>Mr. Copeland's</i> resolutions, 496.....	3	869
Petition presented ( <i>Mr. Copeland</i> ) from farmers, agriculturalists and labourers of Central New England, praying for import duties on agricultural productions that can be grown in the Colony, and read by the Clerk, 505.....	3	877
Petition presented ( <i>Mr. Ewing</i> ) from Public Meeting at Tatham in favour of, 519.....	3	875
AGRICULTURAL SOCIETIES:—		
Motion made ( <i>Mr. Gormly</i> ) for Committee of the Whole, to consider whether a sum equal to their annual income be granted in aid of, 238; Order of the Day postponed, 252, 329; House in Committee, and resolution agreed to, 336.		
ALBURY:—		
PUBLIC PARK:—		
Notification, under the Lands for Public Purposes Acquisition Act, of the resumption of land for, laid on Table, 6.....	5	827
AND WAGGA WAGGA LAND OFFICES:—		
Motion made ( <i>Mr. Day</i> ) for all papers, reports, &c., sent in by the Board appointed to inquire into the working of, 23.		
REMOVAL OF SURVEY OFFICES FROM, TO WAGGA WAGGA:—		
Motion made ( <i>Mr. Day</i> ) for all papers, reports, telegrams, and recommendations respecting, 41; Return to Order laid on Table, 476.....	5	101
ALBURY CATTLE SALE-YARDS BILL:—		
Petition presented ( <i>Mr. Day</i> ) to proceed with Bill under 65th Standing Order, presented and read 1 <sup>o</sup> , 17; <i>Point of Order</i> that Bill was improperly before the House overruled, 42; read 2 <sup>o</sup> , committed, reported with amendments, and report adopted, 43; read 3 <sup>o</sup> , passed, and sent to Council, 49; returned with amendments, 113; Order of the Day postponed, 122; amendments agreed to with amendments, 192; Message to Council, 197; Council agrees to amendments upon their amendments, 200; Assent reported, 219.		
ALLEN, JOHN (See "CROWN LANDS PURCHASES VALIDATION BILL")		
ALLEN, WILLIAM JOHNSTON, ESQUIRE (See also "ELECTORAL"):—		
Return of Writ for Paddington, certifying to election of, 249; sworn, 253; Petition laid on Table to refer Seat to Elections and Qualifications Committee, Petition referred to Elections and Qualifications Committee, 269; Report brought up, 296.....	1	891
ALPHABETICAL REGISTERS:—		
Addresses and Orders passed during the Session, &c.....	1	821
Bills dealt with during the Session.....	1	819
AMMUNITION MANUFACTORY:—		
Correspondence respecting proposed establishment of, laid on Table, 479.....	2	41
ANDERSON'S COMBINATION TRUCKS (See "RAILWAYS").		
ANGLEDPOOL (See "TELEGRAPHS").		
ANIMALS (See "DISEASED ANIMALS AND MEAT BILL").		
ANIMALS INFECTIOUS DISEASES BILL:—		
Message from Governor, 314; Standing Orders suspended, Motion made ( <i>Mr. Garret</i> ) for Committee of the Whole, 326; House in Committee, Resolution reported and agreed to, presented and read 1 <sup>o</sup> , read 2 <sup>o</sup> and committed, reported, report adopted, read 3 <sup>o</sup> , passed and sent to Council, 335; Returned without amendment, 338; Assent reported, 378.	8	665
ANNIVERSARY (See "CENTENARY OF THE COLONY").		
ANSWERS AND QUESTIONS:—		
Sessional Order passed, 10.		
APPEALS (See "CROWN LANDS").		
APPEALS ACT (See "SUPREME COURT APPEALS ACT AMENDMENT BILL").		
APPLICATIONS (See "MINING").		
OPINIONS (See "CIVIL SERVICE").		

INDEX.

v

REFERENCES TO THE VOTES AND PROCEEDINGS, VOL. I—13TH PARLIAMENT—SESSION, 1887-8.		PAPERS.	
		VOL.	PAGE.
<b>A</b>			
<b>APPROPRIATION BILL :—</b>			
Ordered ( <i>Mr. Burns</i> ) founded on Resolutions of Ways and Means, Nos. 10 and 11, presented and read 1°, 627; read 2°; committed, reported without amendment; report adopted; read 3°, passed and sent to Council, 639; returned without amendment, 642; assented to in Council Chamber, 642.			
<b>ARBITRATION (See "TRADES CONCILIATION BILL").</b>			
<b>ARDILL, MR. JOHN ROCHE :—</b>			
Petition from, that owing to the action of the Surveyor-General, he is aggrieved, and has suffered loss, and praying relief, presented 49	2	139	
Motion made ( <i>Dr. Ross</i> ) for correspondence, petitions, claims, &c., for compensation for work done by, as a licensed surveyor, 155; Return to Order laid on Table (not printed), 429.			
<b>ARTILLERY, PERMANENT (See "MILITARY"; also "ELECTORAL").</b>			
<b>ASSEMBLY (See also "ADJOURNMENT"; also "CHAIRMAN OF COMMITTEES"; also "CLERK OF ASSEMBLY"; also "CLOSURE OF DEBATE"; also "DISORDER"; also "PARLIAMENT"; also "PRIVILEGE"; also "SPEAKER"; also "PARLIAMENTARY REPRESENTATIVES ALLOWANCE BILL") :—</b>			
Opening of Session, 1.			
Prorogation Speech, 643.			
Usher of Black Rod delivers Message, 1.			
Vacant Seats, 1, 73, 222, 269, 419.			
Issue and Return of Writ reported, 1, 73, 87, 249 <sup>(3)</sup> , 303, 339, 463.			
Members sworn, 76, 87, 249, 253 <sup>(2)</sup> , 303, 342, 463.			
Members named, 156 <sup>(2)</sup> , 184.			
Members declared guilty of persistent disorder and removed from the Chamber by the Sergeant-at-Arms, 220 <sup>(1)</sup> , 221 <sup>(7)</sup> .			
Member committed to custody of Sergeant-at-Arms, 490.			
Member in custody of Sergeant-at-Arms, 483.			
Member discharged from custody of Sergeant-at-Arms, 485.			
Member's name discharged from Select Committee, 432, 462.			
Member's name added to Select Committee, 89, 280.			
Member's name substituted for another on Select Committee, 585.			
Leave of Absence to Member, 17, 112, 308, 361, 437.			
Leave of Absence to Chairman of Committees, 397, 424.			
Disorder reported from Committee of the Whole and Member removed by Sergeant-at-Arms and suspended for the remainder of the sitting, 345.			
Disorderly words reported from Committee of Supply, 452.			
Disorder reported from Committee of the Whole, 479.			
Words of heat used by Member and withdrawn and apologised for, 374.			
Irregularities in Election and Proclamation curing same, reported, 73.			
<i>Pro forma</i> Bill read 1°, 2.			
Governor's opening Speech, 2; Address-in-Reply, 3, 4; Answer to Address-in-Reply, 5.			
Sittings after midnight, 4, 30, 53, 65, 77, 90, 99, 115, 119, 123, 136, 140, 146, 152, 162, 169, 186, 198, 210, 220, 242, 248, 264, 288, 296, 304, 329, 345, 361, 374, 381, 390, 422, 425, 430, 434, 442, 452, 455, 469, 476, 480, 487, 494, 496, 501, 509, 514, 520, 526, 538, 544, 548, 554, 574, 580, 587, 603, 615, 619, 628, 639.			
Continuous Sitting, 619, 628.			
Elections and Qualifications Committee, 17, 37, 53 <sup>(2)</sup> , 55 <sup>(2)</sup> , 145, 269, 287, 296, 548.			
Deputy Speaker's Commission to administer the Oath of Allegiance, 46.			
Standing Order (Right of Reply)—Additional—passed, 23; Speaker authorized to present to Governor for approval, 28; approval reported, 31.			
Standing Order—Additional—No. 5, 128.			
Standing Orders suspended, 191, 241, 294, 295, 326, 361, 344, 385, 409, 455, 479, 553, 578.			
Standing Orders referred to Standing Orders Committee, 353; Report brought up, 476; ordered to be considered in Committee, 479; Order of the Day postponed, 529, 566, 592.			
Sessional Orders passed, 9, 10 <sup>(9)</sup> , 11 <sup>(9)</sup> , 12 <sup>(2)</sup> , 89 <sup>(3)</sup> , 103, 408.			
Sessional Order rescinded, 325.			
Additional Sitting Day passed, 103, 585 <sup>(2)</sup> .			
Hour of meeting of the House, 224, 303.			
Government Business takes precedence at 7 o'clock, 103, 123, 140, 166, 234, 408, 422, 433, 452, 476, 493, 508, 525, 543, 560, 561, 580, 609.			
Business fixed for a future day to take precedence, 169, 181, 208, 210, 216.			
Interruption to Proceedings, 76, 296.			
Select Committee appointed by ballot, 30.			
Standing Committee appointed by ballot, 508.			
Records of the House removed from custody of the Clerk, 51; motion of <i>privilege</i> moved respecting, Records returned, and motion by leave withdrawn, 53.			
Speaker retires, Deputy Speaker takes Chair, Speaker resumes Chair, 579.			
Report from Select Committee referred back to Committee, 200.			
Order of the Day discharged, 77, 107, 137, 145, 146, 185, 192, 233, 241, 246, 252 <sup>(2)</sup> , 309, 325, 506 <sup>(2)</sup> , 507, 508 <sup>(2)</sup> , 608 <sup>(2)</sup> .			
Bill withdrawn, 107, 137, 146, 146, 192, 233, 241, 246, 349, 389, 506, 508, 585, 608.			
Bill recommitted, 98, 152, 201, 373, 507, 547, 586.			
Recommittal of Bill negatived, 98, 507, 586, 595.			
Notices of Motions of General Business postponed in a bunch, 162, 208, 242, 248, 487, 628.			
Notice of Motion of General Business postponed, 502.			
Orders of the Day of General Business postponed in a bunch, 248, 430, 487.			
Orders of the Day of Government Business postponed in a bunch, 417, 430, 463, 468, 487, 502, 509, 628.			
No Tellers in Division, 59, 140.			
Apology from Mr. Thos. Robertson, for having interrupted proceedings of the House, read by Mr. Speaker, and accepted, 79.			
Entry in Votes and Proceedings expunged by Order, 90, 91.			
Ministerial Statement made by Sir Henry Parkes, 123, 252, 264, 361, 364, 404, 451, 501, 613, 641.			
Motion made adjudging Member guilty of contempt, 156 <sup>(2)</sup> .			
Previous Question moved and negatived, 165.			
Death of Member of, reported, 249.			
Retirement of Mr. Jones, Clerk of, 250.			
Commission appointing Mr. Frederick William Webb to be Clerk produced, and Mr. Webb sworn, 285.			

REFERENCES TO THE VOTES AND PROCEEDINGS, VOL. I—13TH PARLIAMENT—SESSION, 1887-8.	PAPERS.	
	VOL.	PAGE.
<b>A</b>		
<b>ASSEMBLY—(continued):—</b>		
Motion made for Member to be heard, 302 <sup>(2)</sup> .		
Notice of Motion to take precedence of all other business, 328.		
Resolutions, fixing Business for other than a sitting day, rescinded, 585.		
General Orders to take precedence of Motions on Fridays, 593.		
Votes and Proceedings, 1 to 121 .. . . .	1	1
Business undisposed of at close of Session .. . . .	1	645
Attendance of Members in Divisions and Counts-out during the Session .. . . .	1	653
Business of the Session .. . . .	1	655
Weekly Reports of Divisions in Committee of the Whole, Nos. 1 to 22 .. . . .	1	657
Weekly Abstracts of Petitions received, Nos. 1 to 37 .. . . .	1	745
Alphabetical Registers of Bills .. . . .	1	819
Alphabetical Registers of Addresses and Orders .. . . .	1	821
Standing and Select Committees appointed during Session .. . . .	1	831
Explanatory Abstracts of Sums estimated and voted .. . . .	3	851
<b>FREE RAILWAY PASSES TO EX-MEMBERS OF:—</b>		
Motion made ( <i>Mr. Haynes</i> ) that Resolution affirming that Members returned to three Parliaments on ceasing to be Members shall be entitled to a permanent free railway pass, be rescinded, and debate adjourned, 129; Order of the Day postponed, 433; Order of the Day discharged, 506		
<b>FRANKING MEMBERS' CORRESPONDENCE ON PUBLIC BUSINESS —</b>		
Motion made ( <i>Mr. Ewing</i> ) that all letters on public business incidental upon the representation in Parliament of an Electorate shall be carried free by post, 24; and negatived, 25.		
<b>PAYMENT OF MEMBERS (See also "PARLIAMENTARY REPRESENTATIVES ALLOWANCE BILL") :—</b>		
Motion made ( <i>Mr. Fletcher</i> ) for Committee of the Whole to consider the necessary steps to be taken to make provision in the Estimates for, 28, House in Committee, and Resolution agreed to, 42.		
<b>POSTAGE ON CORRESPONDENCE RE-DIRECTED FOR MEMBERS —</b>		
Motion made ( <i>Mr. Chanter</i> ) for no further charge for, and motion not having been put at 7 o'clock, Government business took precedence, 433.		
<b>LIGHTING BUILDINGS WITH ELECTRIC LIGHT :—</b>		
Motion made ( <i>Mr. Thompson</i> ) for all recommendations, tenders, correspondence, &c, in connection with, 103.		
<b>ADDRESSES AND ORDERS :—</b>		
Motion made ( <i>Mr. O'Sullivan</i> ) for a return showing what Resolutions for the production of departmental papers, returns, correspondence, &c., have not been attended to, 118; Returns ( <i>in part</i> ) to Order laid on Table, 191, 223, 257 .. . . .	1	839, 841, 843
Motion made ( <i>Mr. Wall</i> ) for a return showing the number of orders made, for production of papers and returns since 1 January, 1886, which have not been complied with, 210; Returns ( <i>in part</i> ) to an Order, laid on Table, 257, 334 .. . . .	1	845, 847
<b>CENTENNIAL INTERNATIONAL EXHIBITION, MELBOURNE —</b>		
Telegram from Speaker of Legislative Assembly, Victoria, conveying invitation to, read by Mr. Speaker, 563		
<b>SELECT COMMITTEES ON PRIVATE BILLS :—</b>		
Motion made ( <i>Mr. Barbour</i> ), for Committee of the Whole to consider the question of remuneration of Members attending on, 608.		
<b>ASSENT TO BILLS (See "MESSAGES")</b>		
<b>ASSISTANT-EXAMINER OF ACCOUNTS, TREASURY :—</b>		
Return respecting applications for position of, laid on Table, 524 .. . . .	2	111
<b>ASSOCIATION CRICKET GROUND —</b>		
Motion made ( <i>Mr. McElhone</i> ) for a return showing all moneys received, and amount expended by the Trustees, giving particulars 215; Return to Order, laid on Table, 408 .. . . .	8	1021
Return respecting Trustees of, laid on Table, 519 .. . . .	8	1023
<b>TRUSTEES' ACCOUNTS :—</b>		
Motion made ( <i>Mr. McElhone</i> ), for audit and report on; and the Question not having been put at 7 o'clock, Government Business took precedence, 609.		
<b>ASYLUMS :—</b>		
<b>GOVERNMENT :—</b>		
Reports, &c., from the Manager, Matrons, Superintendents, and others, on the Report from the Board appointed to inquire into, laid on Table, 82 .. . . .	4	617
<b>INFIRM AND DESTITUTE —</b>		
Correspondence as to accommodation and treatment of ophthalmic patients, laid on Table, 82. ....	4	607
<b>ATTENDANCES OF MEMBERS IN DIVISIONS AND COUNTS OUT.—</b>		
Sessional paper .. . . .	1	653
<b>ATTENDANCE OFFICERS (See "EDUCATION").</b>		
<b>ATTORNEY-GENERAL :—</b>		
Return, showing names of gentlemen who have held the office under Responsible Government, with the amount of Patent Fees received by each, laid on Table, 144 .. . . .	2	615
Motion made ( <i>Mr. Dibbs</i> ) that the practice of Government paying Counsel's fees to, in addition to his salary, is fraught with danger, and ought to be discontinued forthwith, and debate adjourned, 140; Order of the day postponed, 232, discharged, 586.		
Resignation of office of, by Mr. Wise, 252		
Acceptance of office of, by Mr. Simpson, 264.		
Opinion of Mr. Dalley on Section 4 of Crown Lands Alienation Act of 1861, laid on Table, 500.	5	109
<b>ATTORNEYS BILLS OF COSTS AND PRACTICE OF CONVEYANCING AMENDMENT BILL :—</b>		
Motion made ( <i>Mr. Frank Farnell</i> ) for leave to bring in, presented and read 1 <sup>o</sup> , 191; Order of the Day postponed, 224, 252; read 2 <sup>o</sup> and committed 320; Order of the Day postponed, 341, 386, 433, 493, 579, 593.		
Petition from certificated conveyancers of the Supreme Court of New South Wales, praying for an amendment of the first clause, presented, 277 .. . . .	8	1025
<b>AUBURN PARK ROAD TRUST :—</b>		
Motion made ( <i>Mr. Frank Farnell</i> ) for all papers and minutes in connection with, 196; Return to Order laid on Table, 341. ....	5	967
<b>AUDITOR-GENERAL :—</b>		
Report of, on Statement of Receipts and Expenditure for the Year 1886, laid on Table, 2 .. . . .	3	509
Report of, on Statement of Receipts and Expenditure for 1887, laid on Table, 563 .. . . .	3	657
<b>AUSTRALIA (See "COLONY OF AUSTRALIA BILL").</b>		

REFERENCES TO THE VOTES AND PROCEEDINGS, VOL. I—13TH PARLIAMENT—SESSION, 1887-8.		PAPERS.	
		VOL.	PAGE.
<b>A</b>			
<b>AUSTRALASIAN NAVAL FORCE BILL :—</b>			
Motion made ( <i>Sir Henry Parkes</i> ) for Committee of the Whole—motion made, “That Question be now put”— <i>Disorder</i> in division, and Member named, and motion of contempt moved, bars opened, another Member named, and motion of contempt moved, 156; and withdrawn, and motion That Question be now put, withdrawn,—original question carried, 157; Message from Governor, 157; House in Committee, Resolution agreed to, presented and read 1 <sup>o</sup> , 166; motion made for 2 <sup>o</sup> , amendment “This day six months” moved and debate adjourned, 181; debate resumed, amendment negatived, 186; read 2 <sup>o</sup> and committed, 187; further considered in Committee, 197; reported without amendment and report adopted, 198; read 3 <sup>o</sup> , passed, and sent to Council, 210; returned without amendment, 230; assent reported, 237.	2	67	
<b>AUSTRALASIAN STEAM NAVIGATION COMPANY'S WHARF :—</b>			
<b>PURCHASE BY THE GOVERNMENT OF LAND ADJOINING :—</b>			
Motion made ( <i>Mr. Melville</i> ) for a Select Committee to inquire into, Committee appointed by ballot, 30; Report brought up, 305.....	3	917	
Motion made ( <i>Mr. Dibbs</i> ) for an Address to the Governor that the evidence of the Select Committee discloses injudicious and unsatisfactory administration by the Government, and that the amount paid was in excess of its value, and negatived, 329.	3	1011	
Correspondence respecting, laid on Table, and referred to Select Committee, 52 .....	3	1013	
<b>PURCHASE BY THE GOVERNMENT OF :—</b>			
Motion made ( <i>Mr. Trickett</i> ) for all claims, correspondence, valuations, &c., connected with, 136 Return to Order laid on Table, 191 .....	3	1013	
<b>AUSTRALIAN MUTUAL PROVIDENT SOCIETY'S ACTS AMENDMENT BILL :—</b>			
Received from Legislative Council and on motion ( <i>Mr. Day</i> ) read 1 <sup>o</sup> , 326; Order of the Day postponed, 365; Question proposed, That this Bill be now read 2 <sup>o</sup> , and the motion not having been put at 7 o'clock, Government business took precedence, 452; Order of the Day postponed, 476; read 2 <sup>o</sup> , committed, reported without amendment, report adopted, 506; read 3 <sup>o</sup> , passed, returned to Council without amendment, 512; assent reported, 524.			
<b>AUTOMATIC ELECTRIC CARS :—</b>			
Correspondence respecting, laid on Table, 373 .....	6	1125	
<b>B</b>			
<b>BAILIFFS (See “ADMINISTRATION OF JUSTICE”).</b>			
<b>BALLOT :—</b>			
For Select Committee, 30.			
For Parliamentary Standing Committee on Public Works, 508.			
<b>BALLOTING FOR SELECT COMMITTEES :—</b>			
Sessional Order passed, 11.			
<b>BALMAIN (See “BOROUGH OF BALMAIN WHARVES BILL;” also “WHARVES”).</b>			
<b>BALRANALD :—</b>			
<b>WATER SUPPLY :—</b>			
Notification under Country Towns Water and Sewerage Act, authorizing the construction of works for, laid on Table, 6 .....	5	881	
<b>BANK LIABILITIES AND ASSETS :—</b>			
For quarter ended 30th June, 1887, laid on Table, 5 .....	3	843	
For quarter ended 30th September, 1887, laid on Table, 135 .....	3	845	
For quarter ended 31st March, 1888, laid on Table, 475 .....	3	847	
<b>BANKING, LAND, BUILDING, AND INVESTMENT COMPANIES :—</b>			
General Summary of Liabilities and Assets for quarter ended 31 March, 1888, laid on Table, 475..	3	849	
<b>BANKRUPT (See “PRIVILEGE”).</b>			
<b>BANKRUPTCY ACT OF 1887 :—</b>			
General Rules under, laid on Table, 257, 267, 635 .....	2	709, 711, 727.	
Regulations for 1887, 451 .....	2	731	
<b>BANKRUPTCY ACT AMENDMENT BILL :—</b>			
Motion made ( <i>Mr. William Clarke</i> ) for leave to bring in, presented, and read 1 <sup>o</sup> , 586; read 2 <sup>o</sup> , committed, reported with an amendment, report adopted, 594; read 3 <sup>o</sup> , passed, sent to Council, 598; returned with an amendment, 614; amendment agreed to, 627; assent reported, 629.			
<b>BANKRUPTCY BILL :—</b>			
Motion made ( <i>Mr. Wise</i> ) for leave to bring in, 16; House in Committee, Resolution agreed to, presented and read 1 <sup>o</sup> , Message from Governor, 29; motion made for 2 <sup>o</sup> and debate adjourned, 35; resumed, 49; read 2 <sup>o</sup> and committed, 50; further considered in Committee, 53, 65, 71, 82, 85; reported with amendments and report adopted, 85; recommitted reported 2 <sup>o</sup> , 97, 98; report 2 <sup>o</sup> adopted, 104; read 3 <sup>o</sup> and passed, 106; sent to Council, 107; returned with amendments, 158; amendments agreed to and disagreed to, 166; Message to Council, 174; Council does not insist on its amendments disagreed to, 185; assent reported; 219.	2	729	
<b>BARCELONA :—</b>			
Despatches respecting trade in wheat with Australia, laid on Table, 335, 475 .....	8	1309, 1311	
<b>BARCLAY, ISAAC (See also “CROWN LANDS”) :—</b>			
Motion made ( <i>Mr. Martin</i> ) for a Select Committee to inquire into Claim of, for compensation for losses sustained in defending his title to land held under Crown Grant, 165; report brought up, 609 .....	5	487	
<b>BARLING, MR. JOSEPH (See “CIVIL SERVICE”).</b>			
<b>BARMAIDS :—</b>			
<b>EMPLOYMENT OF, IN PUBLIC-HOUSES :—</b>			
Petition from Women's Christian Temperance Union and others, that Licensing Law may be amended so as to prohibit, presented, 22.....	7	711	
<b>BARRIER RANGES (See “RAILWAYS”).</b>			
<b>BARISTERS BILL :—</b>			
Motion made ( <i>Mr. J. P. Abbott</i> ) for leave to bring in, 123.			
<b>BATH, CHARLES :—</b>			
Petition to be heard by counsel, attorney, or agent, before the Select Committee on Silverton Tramway Act Amending Bill, presented, 341.....	2	1097	
<b>BATHGATE, MESSRS. LEONARD AND (See “ROADS”).</b>			
<b>BATHURST TO BOURKE (See “RAILWAYS”).</b>			
<b>BEATY, MR. J. M. :—</b>			
Petition from, in reference to public services, and praying for consideration of his case, 463.....	2	141	

REFERENCES TO THE VOTES AND PROCEEDINGS, VOL. I—13TH PARLIAMENT—SESSION, 1887-8.	PAPERS.	
	VOL.	PAGE.
<b>B</b>		
BEER (See "SPIRITS").		
BEER DUTY ACT:— Regulations under, laid on Table, 35 .....	3	883
BEHAN, DANIEL:— LATE SERGEANT IN NEW SOUTH WALES ARTILLERY:— Motion made ( <i>Mr. Alfred Allen</i> ) for a Select Committee to inquire into discharge of, 71; name added to Committee, 89.		
BENN, ZACHARY, CONDITIONAL PURCHASE OF (See "CROWN LANDS").		
BENNETT, MR. C. E.:— Report of, on Prospect Dam, laid on Table, 529 .....	5	840
BEXLEY (See "RAILWAYS").		
BILLS OF COSTS (See "ATTORNEYS BILLS OF COSTS AND PRACTICE OF CONVEYANCING AMENDMENT BILL").		
BILLS:— Recommitted, 98, 152, 201, 373, 507, 547, 583. Recommittal negatived, 507, 586, 595. Withdrawn, 107, 137, 145, 146, 192, 233, 241, 246, 349, 389, 506, 508, 585, 603. Brought in on order of leave of former Bill, 246, 349. Alphabetical Registers of .....	1	819
BILLS OF SALE ACT AMENDING BILL:— Motion made ( <i>Mr. Day</i> ) for leave to bring in, 408; presented and read 1 <sup>o</sup> , 420; Order of the Day postponed, 476; read 2 <sup>o</sup> , committed, reported without amendment, report adopted, 507; read 3 <sup>o</sup> , passed, sent to Council, 513.		
BILOELA (See "COCKATOO ISLAND").		
BINGERA DISTRICT (See "MINING").		
BISHOP, MR. C. E.:— Report of, on Prospect Dam, laid on Table, 529.....	5	849
BLACK ROD:— Delivers Message, from Governor, 1, 642.		
BLAYNEY (See "RAILWAYS").		
BLUE BOOK:— For 1887 laid on Table, 479 .....	7	713
BLUE METAL CONTRACT (See "RAILWAYS").		
BLUFF RIVER (See "RAILWAYS").		
BOARDS (See "PASTURES AND STOCK PROTECTION BOARDS"; also "CIVIL SERVICE"; also "ABORIGINALS OF THE COLONY.")		
BOMBALA (See "ROADS"; also "RAILWAYS").		
BONDI ROYAL AQUARIUM:— Return respecting occupation of the 100-foot reservation at Dixon's Bay, laid on Table, 553.....	5	799
BORENORE (See "RAILWAYS").		
BORING OPERATIONS (See "MINING"; also "STOCK").		
BOROUGH OF BALMAIN WHARVES BILL:— Petition presented ( <i>Mr. Garrard</i> ) for leave to proceed with under the 65th Standing Order, presented and read 1 <sup>o</sup> , 9; read 2 <sup>o</sup> , 41; committed, reported with amendments, and Report adopted, 42; read 3 <sup>o</sup> , passed, and sent to Council, 64; returned with amendments, 151; amendments agreed to and Message to Council, 162; assent reported, 171.		
BOTANY BAY:— NUISANCE ON NORTH SHORE OF:— Motion made ( <i>Mr. Stephen</i> ) for Committee of the Whole for Address to Governor for provision to be made on the Estimates for the abatement of, and withdrawn, 128.		
PARK RESERVE AT KURNELL:— Motion made ( <i>Mr. Carruthers</i> ) that immediate steps be taken to secure, adjacent to the place where Captain Cook first landed in Australia, and withdrawn, 232.		
BOTANY WEST (See "ROCKDALE MUNICIPALITY RE-NAMING BILL").		
BOTTRELL, DR.:— CLAIM OF, TO FORESHORES OF SYDNEY HARBOUR:— Motion made ( <i>Mr. Lyne</i> ) for all papers connected with, 40; Return to Order, laid on Table, 185.	3	885
BOURKE (See also "RAILWAYS"). Notification under the Country Towns Water and Sewerage Act, completion of Water Supply Works for, 475 .....	5	883
BOWRAL (See "RAILWAYS").		
BOWLER, THE QUEEN v. (See "ADMINISTRATION OF JUSTICE").		
BOYS REFORMATORY (See "REFORMATORY FOR BOYS").		
BRAKE CONTINUOUS (See "RAILWAYS").		
BRAZENOR AND VALENTINE (See "RAILWAYS").		
BREACH OF PRIVILEGE (See "PRIVILEGE").		
BRENNING, CHARLOTTE:— Petition from, that she served for three years as a Teacher under the Public Instruction Department, and through being sent to places where great hardships had to be endured, her health was greatly affected, and having applied for removal, her resignation was accepted, and praying the appointment of a Select Committee, presented, 135.....	4	515
BREWARRINA (See "CUSTOMS"; also "RAILWAYS").		
BRIDGES (See also "ROADS"; also "PARLIAMENTARY STANDING COMMITTEE ON PUBLIC WORKS):— HIGH-LEVEL OVER RIVER DARLING:— Motion made ( <i>Mr. J. P. Abbott</i> ) that necessary steps should be taken to inquire into necessity for, at Wilcannia, at Menindie, and Wentworth, 43.		
OVER RIVER MURRAY AT MULWALA:— Motion made ( <i>Mr. Lyne</i> ) for all correspondence, plans, &c., relating to proposed, 64; Return to Order, laid on Table, 277 .....	5	1025
PARRAMATTA RIVER AND IRON COVE:— Motion made ( <i>Mr. Frank Farnell</i> ) for all papers in connection with construction of, 118.		
UPPER MURRAY:— Motion made ( <i>Mr. Lyne</i> ) for papers in reference to erection of, 308.		
VOTE OF £55,000 ON ESTIMATES FOR 1888:— Schedule showing proposed distribution, laid on Table, 224.....	5	1021
CONTRACT FOR OVER THE PATERSON RIVER:— Motion made ( <i>Mr. Hurley</i> ) for Select Committee, 404.		
IRON, BETWEEN PARRAMATTA AND PENRITH:— Copy of instructions issued to Professor Warren to inquire and report upon, laid on Table, 429....	6	1025



REFERENCES TO THE VOTES AND PROCEEDINGS, VOL. I—13TH PARLIAM NT—SESSION, 1887-8.	PAPERS.	
	VOL.	PAGE.
<b>B</b>		
<b>BRIDGES—(continued) :—</b>		
<b>IRON COVE AND PARRAMATTA RIVER :—</b>		
Return to Order (Second Session 1887, in completion) laid on Table, 432.....	5	823
<b>DUPLICATED LINE BETWEEN PARRAMATTA AND PENRITH :—</b>		
Motion made ( <i>Mr. J. P. Abbott</i> ) for papers, plans, &c., in reference to, 519.		
Motion made ( <i>Mr. J. P. Abbott</i> ) for copy of Professor Warren's report and correspondence relative thereto, 519.		
<b>BRIGADE OFFICE (See "MILITARY").</b>		
<b>BRISBANE TO SYDNEY (See "RAILWAYS").</b>		
<b>BRITTEN, THE Rev. H. H., OF RYDE :—</b>		
Motion made ( <i>Mr. J. S. Farnell</i> ) for all documents, depositions, &c., in case of alleged arson preferred against, and any letters on the subject of the conduct of Mr. Manning, Coroner at Ryde, 136; Return to Address laid on Table, 326 .....	2	639
Motion made ( <i>Mr. Frank Farnell</i> ) for letters written to the Minister of Justice by Mr. J. E. Manning, on 2nd December, 1886, and 20th January, 1887, in reference to the alleged Arson Case at Ryde, 344; Return to Address, laid on Table, 415 .....	2	679
<b>BROKEN HILL (See "RAILWAYS").</b>		
<b>BROKEN HILL AND SUBURBAN GAS COMPANY'S BILL :—</b>		
Standing Order suspended to admit of presentation of Petition to introduce; Petition presented ( <i>Mr Day</i> ), 361; leave given, presented and read 1 <sup>o</sup> , 365; referred to Select Committee, 369; Report brought up, 429; Order of the Day postponed, 476; read 2 <sup>o</sup> , committed, reported with an amendment, report adopted, 507; read 3 <sup>o</sup> , passed, sent to Council, 513.	2	817
<b>BROKEN HILL TRAMWAY BILL :—</b>		
Petition presented ( <i>Mr. O'Connor</i> ) for leave to bring in, 81; leave given, presented, and read 1 <sup>o</sup> , 147; referred to Select Committee, 155; report brought up, and referred back to Select Committee to take further evidence, 200; report brought up, 2 <sup>o</sup> , 302; Order of the Day postponed, 508.	2	825
Petition from W. P. Macgregor, W. R. Wilson, and W. Jamieson, that their interests will be seriously affected and prejudiced if the Bill be passed, and praying to be heard before the Select Committee, presented, 192.....	2	859
Petition from Inhabitants of Broken Hill and Silverton, praying the House to refuse to sanction the construction of the said Tramway, presented, 295.....	2	861
<b>BROKEN HILL WATER SUPPLY BILL :—</b>		
Petition presented ( <i>Mr. Brunker</i> ) for leave to bring in 344, leave given 348, presented and read 1 <sup>o</sup> , 353; referred to Select Committee, 361; Report brought up, 537.....	2	863
<b>BROKERS (See "MERCANTILE BROKERS").</b>		
<b>BROUGHM, JAMES KENNEDY (See "MINING").</b>		
<b>BROWNE, THOMAS FREDERIC DE COURCY, ESQUIRE :—</b>		
Return of writ for Wentworth, certifying to election of, reported, 73; sworn, 76.		
<b>BUCHANAN, DAVID, BARRISTER-AT-LAW :—</b>		
Petition in favour of Cremation Bill, presented, 272.....	8	1049
Return of Writ for Central Cumberland, certifying to election of, reported, sworn, 463.		
<b>BULLI COLLIERY :—</b>		
<b>EXPLOSION :—</b>		
Copy of the Attorney-General's opinion respecting, laid on Table, 35.....	8	435
Motion made ( <i>Mr. Melville</i> ) for all replies, letters, &c., by Mr. Mackenzie respecting Commission's Report on, 185; Return to Order, laid on Table, 196 .....	8	437
Motion made ( <i>Mr. Melville</i> ) that this House do now adjourn to consider statements of Examiner of Coal-fields in papers laid on Table, and reflecting upon Commissioners report on, and negatived, 200.		
<b>BULLI COLLIERY DISASTER FUND BILL :—</b>		
Received from Legislative Council, and on motion ( <i>Mr. Gould</i> ), read 1 <sup>o</sup> , 398; Order of the Day postponed, 454; motion made for 2 <sup>o</sup> , and, the Question not having been put at 7 o'clock, Government Business took precedence, 543; Order of the Day postponed, 546, 593, 628.		
<b>BULK SAMPLES OF ORE (See "MINING").</b>		
<b>BUNABA NORTH (See "CROWN LANDS").</b>		
<b>BURNS, THE HONORABLE JOHN FITZGERALD :—</b>		
Ministerial statement made by in reference to revenue receipts and expenditure during quarter ended 31st March, 1888, 361.		
<b>BUSHRANGERS (See "HUSBAND, JAMES H., CLAIM OF").</b>		
<b>BUSINESS DAYS :—</b>		
Sessional Orders passed, 9.		
<b>BUSINESS OF THE HOUSE :—</b>		
Sessional Order passed, 11.		
Precedence of Government Business, Sessional Order passed, 10.		
Do do on Friday, (additional sitting day,) after 7 o'clock, 103, 123, 140, 166, 234.		
Precedence of Government Business, General Business, Sessional Order passed, 10.		
Fixed for a future day to take precedence of all other business, 169, 181, 208, 210, 216.		
Precedence of Government Business on Tuesday at 7 o'clock, 408, 422, 433, 452, 476, 493, 508, 523, 525, 543, 561, 580, 609.		
Friday made a Sitting Day, with General Business to take precedence, 585.		
Monday made a Sitting Day, with Government Business to take precedence, 585.		
Orders of the Day of General Business to take precedence of Motions on Friday, 593.		
<b>PRIVILEGE :—</b>		
Motion made ( <i>Mr. Garvan</i> ) that Sir Henry Parkes, Colonial Secretary and Premier, having, tendered his resignation as a Member, and said resignation having been accepted, this House declines to transact any further business till the Premier occupies his Seat as an elected Member of this House, and negatived, 76.		
<b>BUSINESS OF THE SESSION :—</b>		
Sessional Paper .....	1	655
<b>BUTCHER, DR. (See "RABBIT PEST").</b>		
<b>BUTTERLEY, MRS. :—</b>		
<b>CLAIM OF :—</b>		
Motion made ( <i>Mr. Schey</i> ) for Select Committee, and that Return to Order ( <i>Second Session, 1887</i> ) be referred, 12; Report brought up, 140. ....	6	647
<b>BY-LAWS :—</b>		
<b>LAI D ON TABLE :—</b>		
University of Sydney, 6, 257 (2) .....	4	557, 569, 571
Free Public Library, Gunnedah, 257 .....	4	597

REFERENCES TO THE VOTES AND PROCEEDINGS, VOL. I—13TH PARLIAMENT—SESSION, 1887-8.		PAPERS.	
		VOL.	PAGE.
<b>B</b>			
BY-LAWS—(continued):—			
Laid on Table—(continued):—			
Municipalities Act:—			
Borough of Gosford, 6, 475, ...		2	347, 349
Do Alexandria, 6		2	309
Do Newcastle, 6, 257, 273		2	379, 381, 383
Do Armidale, 52		2	441
Do East St. Leonards, 52		2	477
Do West Maitland, 63		2	425
Do Kempsey, 63		2	355
Do Goulburn, 97		2	513
Do Bourke, 97		2	319
Do Marrickville, 128		2	371
Do Narrandera, 174, 403		2	375, 377
Do East Maitland, 191		2	339
Do Burwood, 223, 257		2	325, 327
Do Waverley, 334		2	421
Do Cootamundra, 369		2	333
Do North Willoughby, 369		2	387
Do Balmain, 403		2	311
Do Mudgee, 484		2	373
Do Bathurst, 543, 619		2	313, 317
Do Cudgegong, 578		2	337
Municipal District of Silverton, 6		2	397
Do Wentworth, 6, 484		2	423
Do Parkes, 6		2	389
Do Dubbo, 6		2	463
Do Balranald, 6		2	457
Do Glen Innes, 6, 513		2	345
Do Broughton Creek and Bomaderry, 128		2	323
Do Hay, 174		2	351
Do Gunnedah, 191		2	525
Do Lismore, 257		2	369
Do Coonamble, 257		2	331
Do Cobar, 257		2	329
Do Bowral, 257		2	461
Do Adamstown, 273		2	293
Do Taree, 273		2	405
Do Five Dock, 273		2	489
Do North Illawarra, 369		2	385
Do Waratah, 403		2	551
Do Prospect and Sherwood, 429		2	395
Do Inverell, 429		2	353
Do Port Macquarie, 475		2	391
Do Ulladulla, 475, 501		2	417, 419
Do Tenterfield, 484		2	407
Do Glen Innes, 6		2	499
Do Tumut, 543		2	539
Do St. Peters, 543		2	403
Nuisances Prevention Act:—			
Borough of Woollahra, 6		2	439
Do Newcastle, 97		2	433
Do Gunnedah, 191, 525		2	525
Do North Willoughby, 634		2	437
Municipal District of St. Peters, 6		2	435
Do Dubbo, 6		2	463
Do Balranald, 6		2	457
Do Glen Innes, 6		2	499
Do Armidale, 52		2	411
Do East St. Leonards, 52		2	477
Do Goulburn, 97		2	513
Do Bega, 257		2	427
Do Hamilton, 257		2	429
Do Bowral, 257		2	461
Do Five Dock, 273		2	489
Do Lismore, 302		2	431
Do Waratah, 403		2	551
Do Tumut, 543		2	539
Country Towns Water and Sewerage Act:—			
Borough of Wagga Wagga, 6		5	887
Do Bathurst, 6		5	789
Municipal District of Forbes, 352		5	891
BYROCK (See "RAILWAYS").			
<b>C</b>			
CABLE (See "TELEGRAPHS"; also "TELEPHONES").			
CAMERON, ANGUS, Esq., M.P.:—			
Elected as Chairman of Committees, 9.			
Commission to, as Deputy Speaker, to Administer the Oath of Allegiance, 19.			
Absence of, through illness reported, 70, 383.			
Leave of absence granted to Chairman of Committees on account of serious illness, 397, 424.			
CAREENING COVE (See "RECLAMATION OF NEUTRAL BAY AND CAREENING COVE.")			
CARRIAGE OF WOOD AND OTHER PRODUCE:—			
Original Tenders for, from Railway Station, Redfern, and Darling Harbour, laid on Table (as Exhibits only), 454.			
CASSILIS:—(See "RAILWAYS").			

REFERENCES TO THE VOTES AND PROCEEDINGS, VOL. I.—13TH PARLIAMENT—SESSION, 1887-8.	PAPERS.
	VOL. PAGE.
<b>C</b>	
CASTINGS FOR HUNTER RIVER DISTRICT :— Tenders for supply of, laid on Table, 308 .....	3 913
CASTLEREAGH AND ELIZABETH STREETS PROPERTY (See "EDUCATION.")	
CASUAL LABOUR BUREAU :— Return respecting, laid on Table, 35 .....	8 1927
CATTLE SALE YARDS (See "WEST MAITLAND CATTLE SALE YARDS BILL.")	
CEMETERIES BILL :— Motion made ( <i>Mr. J. P. Abbott</i> ) for leave to bring in, presented and read 1°, 397; Order of the Day postponed, 543; discharged and Bill withdrawn, 585.	
CEMETERY :— PRESBYTERIAN, AT MACLEAN :— Motion made ( <i>Mr. McFarlane</i> ) for a Select Committee to inquire into claims of Messrs. J. Macdonald, F. Mackenzie, and D. Shearer, to be reinstated as Trustees, 71; petition presented on 11th May, 1887, referred, 122; Petition from Moderator of the General Assembly for leave to be represented before the Select Committee, presented, 128 .....	8 1255
ROOKWOOD AND WAVERLEY :— Information respecting the Church of England Chaplains at, laid on Table, 144 .....	8 1263
LAND FOR PUBLIC PURPOSES ACQUISITION ACT :— Resumption of land for Public Cemetery at Singleton, notification laid on Table, 252 .....	8 1223
DEVONSHIRE-STREET :— Return of names of Trustees of, laid on Table, 263. ....	8 1055
Motion made ( <i>Mr. Day</i> ) to close, and motion withdrawn, 268.	
CENSURE (See "VOTE OF CENSURE").	
CENSUS :— Return showing estimated population on 31st December, 1877, of New South Wales and Victoria respectively, laid on Table, 352 .....	7 1393
CENTENARY CELEBRATION ACT AMENDMENT BILL :— Motion made ( <i>Mr. Dibbs</i> ) for leave to bring in, presented and read 1°, 59; Order of the Day postponed, 103, 192; Order of the Day discharged and Bill withdrawn, 216.	
CENTENARY CELEBRATION ACT AMENDMENT BILL (No. 2) :— Motion made ( <i>Mr. Dibbs</i> ) that Order of Leave be read, entry in Votes and Proceedings read by Clerk, presented and read 1°, 246; Order of the Day postponed, 252; motion made for 2°, and Debate adjourned, 285; resumed and negatived, 288.	
CENTENARY OF THE COLONY :— Motion made ( <i>Sir Henry Parkes</i> ) for Committee of the Whole to consider Resolutions to mark in a fitting manner, House in Committee, Resolutions reported and agreed to, 114. Motion made ( <i>Mr. Garvan</i> ) for Committee of the Whole to consider Resolution offering prizes in connection with the Celebration, 136; Order of the Day postponed, 147; Order of the Day discharged, 185. Statement of amounts paid, or passed for payment, on account of the Celebration, up to 30 April 1888, laid on Table, 437 .....	8 1029
RELIEF TO POOR OF SYDNEY :— Information respecting, laid on Table, 302 .....	8 1031
CENTENNIAL INTERNATIONAL EXHIBITION, MELBOURNE :— INVITATION TO LEGISLATIVE ASSEMBLY :— Telegram from Speaker of the Legislative Assembly, Victoria, conveying, read by Mr. Speaker, 563.	
PORTRAIT OF WILLIAM CHARLES WENTWORTH :— Letter from Executive Commissioner asking for loan of, and Resolution passed against sending, 569.	
CENTENNIAL PARK :— Motion made ( <i>Mr. O'Sullivan</i> ) for all papers, &c., in connection with scheme of, 208. Motion made ( <i>Mr. Dibbs</i> ), for papers relating to construction and dedication, 308. Statement of Payments made on account of, from 1st August, 1887, to 21st March, 1888, laid on Table, 352 .....	5 813
PETITION OF RESIDENTS OF WOLLAHRA :— Praying for a gate to be placed at the top of Moncur-street, 505 .....	5 815
CENTRAL CUMBERLAND (See "ELECTORAL").	
CENTRAL POLICE COURT (See "PARLIAMENTARY STANDING COMMITTEE ON PUBLIC WORKS.")	
CHAIRMAN OF COMMITTEES :— Mr. Cameron elected, 9; Deputy Speaker's Commission to administer the Oath, 17. House informed of Mr. Cameron's absence through illness, 70, 383. Mr. Cameron granted leave of absence on account of serious illness, 397, 424. Mr. Slattery appointed for day only, 70, 342, 344, 343. Deputy reports disorder from Committee of the Whole, 345, 479. Mr. Garrard appointed for day only, 359, 363, 385. Motion made ( <i>Sir Henry Parkes</i> ) as a matter of urgency to suspend Standing Orders, to allow appointment of, for this day only, 385. Deputies appointed to act temporarily in absence of Chairman, 389. Mr. Speaker calls on Ninian Melville, Esq., to act as Deputy for the day only, 397, 416, 429, 442, 451, 463, 479, 496, 506, 532, 543, 547, 560. Mr. Speaker calls on Jacob Garrard, Esq., to act as Deputy for the day only, 403, 425, 432, 468, 484, 493, 500, 513, 538, 543, 573. Mr. Speaker calls on Thomas Michael Slattery, Esq., to act as Deputy for the day only, 408, 521. Mr. Speaker calls on Albert John Gould, Esq., to act for the day only, 420, 437, 454, 476, 519, 565.	
CHAMBERS, MR. T. W. (See "ADMINISTRATION OF JUSTICE").	
CHANTER, MR. :— A MEMBER FOR THE MURRAY :— Declared guilty of persistent disorder and removed by Sergeant-at-Arms from the Chamber, 220.	
CHAPLAINS :— Information respecting the Church of England, at Rookwood and Waverley Cemeteries, laid on Table, 144 .....	8 1263
CHARGES (See "LUCAS, SURVEYOR").	
CHARITIES (See also "STATISTICS"). Report of the Inspector of Public, for 1886, laid on Table, 52 .....	4 691
"CHELYDRA" S.S. (See "CHINESE.")	

REFERENCES TO THE VOTES AND PROCEEDINGS, VOL. I.—13TH PARLIAMENT—SESSION, 1887-8.	PAPERS.	
	VOL.	PAGE.
<b>C</b>		
<b>CHINESE</b> (See also "ADJOURNMENT"; also "CHINESE RESTRICTION AND REGULATION BILL," 455) :—		
<b>INFUX OF :—</b>		
Information respecting alleged, from New Caledonia, laid on Table, 174 .....	2	207
Correspondence respecting, laid on Table, 196 .....	2	201
Motion made ( <i>Sir Henry Parkes</i> ) for Committee of the Whole, 196; House in Committee, and resolution agreed to, 201.		
Motion made ( <i>Mr. Thompson</i> ) for a Select Committee to inquire into the influx of, their habits, employments, terms on which the Coolie class have immigrated here, and all matters connected therewith, 237; leave given to sit during adjournment and inspect premises, 302.		
Motion made ( <i>Mr. Thompson</i> ) for return showing number who paid poll-tax and number who exhibited letters of naturalization for 1886 and 1887, 307; Return to Order, laid on Table, 335.	2	209
Petition presented ( <i>Mr. Street</i> ) Chinese merchants of Sydney in reference to their existing rights, under the Treaty of Peking, read by the Clerk, 519 .....	2	223
<b>IN HER MAJESTY'S COLONIES :—</b>		
Despatch respecting, laid on Table, 344 .....	2	221
<b>IMMIGRATION :—</b>		
Ministerial Statement made by <i>Sir Henry Parkes</i> , 364, 451.		
Further Correspondence respecting, laid on Table, 369 .....	2	203
Petition presented from Chinese residents upon the subject, and read by the Clerk, 454 .....	2	225
Return respecting passengers by steamships "Afghan," "Tsinan," "Guthrie," and "Menmuir," laid on Table, 454 .....	2	211
Motion made ( <i>Mr. Dibbs</i> ) for adjournment of the House to bring under the notice of the Government the decision of the Supreme Court, and the intention of the Government in regard thereto, in the matter of the illegal detention of certain Chinese, 463.		
Motion made ( <i>Mr. Slattery</i> ) for adjournment of the House in reference to the remission of £900 of a fine of £1,000 inflicted on the captain of the s.s. "Chelydra" for carrying more than the legal number of Chinese, 525; papers relating to, laid on Table, 538 .....	2	213
Despatch respecting treaty between the Governments of China and the United States on the subject, laid on Table, 529 .....	2	217
<b>VOTE OF CENSURE :—</b>		
Motion made ( <i>Mr. Dibbs</i> ), condemning the acts of the Government in reference thereto, and amendment moved and negatived, 468.		
<b>CONFERENCE :—</b>		
Correspondence respecting, laid on Table, 479 .....	2	189
Copy of Papers, being telegrams and Draft Bill agreed upon, laid on Table, and read by the Clerk, 520 .....	2	195
Proceedings of, laid on Table, 524 .....	2	171
<b>CHINESE RESTRICTION AND REGULATION BILL :—</b>		
Message from Governor, 454; Standing Orders suspended, House in Committee, Resolution agreed to, presented, read 1 <sup>o</sup> , read 2 <sup>o</sup> ; Point of Order, that Bill was beyond order of leave ruled against by <i>Mr. Speaker</i> ; committed, reported with amendments, report adopted, 455; read 3 <sup>o</sup> , passed, and sent to Council, 456; returned with amendments, 514; motion made ( <i>Sir Henry Parkes</i> ) to consider amendments in Committee, and <i>Mr. Speaker</i> called attention to the nature of one of the amendments, 525; House in Committee, and amendments agreed to, disagreed to, including the amendment in the title, and amended others, 526; message to Council, 531; Council insists on some amendments and does not insist on others, 566; Assembly does not insist on its disagreements, nor on Assembly's amendments to which the Council disagreed, 573; assent reported, 585.	2	227
<b>CHLOROFORM, DEATHS UNDER :—</b>		
Motion made ( <i>Mr. Withers</i> ) for return of particulars of, 404; Return to Order, laid on Table, 578.	8	1051
<b>CHRISTENSON, REGINA v.</b> (See "ADMINISTRATION OF JUSTICE").		
<b>CHRISTIAN CHAPEL LANDS SALE BILL :—</b>		
Petition presented ( <i>Mr. Alfred Allen</i> ) for leave to bring in, 168; leave given, presented and read 1 <sup>o</sup> , 174; referred to Select Committee, 185; Report brought up, 224; Order of the Day postponed, 325; read 2 <sup>o</sup> , committed, reported with amendment, Report adopted, 386; read 3 <sup>o</sup> , passed, and sent to Council, 389; returned without amendment, 426; assent reported, 461.	2	883
<b>CHURCH AND SCHOOL LANDS MINING BILL :—</b>		
Motion made ( <i>Mr. Inglis</i> ) for Committee of the Whole to consider introduction of Bill to make better provision for, 161; House in Committee, resolution agreed to, Message from Governor, 166; presented and read 1 <sup>o</sup> , 573; read 2 <sup>o</sup> , committed, reported with amendments, report adopted, 580; read 3 <sup>o</sup> , passed, and sent to Council, 585; returned with an amendment, 615; amendment agreed to, 627; assent reported, 629.		
<b>CHURCH AND PERKINS STREETS, NEWCASTLE, BILL :—</b>		
Petition presented ( <i>Mr. Fletcher</i> ) for leave to bring in, 48; leave given, presented and read 1 <sup>o</sup> , 52; referred to Select Committee, 60; Report brought up, 76; read 2 <sup>o</sup> , committed, reported without amendment and report adopted, 107; read 3 <sup>o</sup> , passed, and sent to Council, 112; returned without amendment, 152; assent reported, 171.	2	891
<b>CHURCH OF ENGLAND PROPERTY BILL :—</b>		
Received from Legislative Council, and, on motion of <i>Mr. Abigail</i> , read 1 <sup>o</sup> , 455; Order of the Day postponed, 593; motion made for 2 <sup>o</sup> ; <i>Speaker</i> ruled that although it was introduced in the Council as a Private Bill, it should be treated in this House under the 69th Standing Order as a Public Bill; motion for adjournment of Debate moved, and House counted out, 599.		
Petition presented from <i>Captain Rossi</i> , praying to be heard in opposition to the Bill before the Bar of the House or the Select Committee, 538 .....	2	897
Petition presented from <i>Daniel P. M. Halbert, M.A., &amp;c.</i> , against, 560 .....	2	899
<b>CHURCH-STREET, PARRAMATTA</b> (See "PARRAMATTA CHURCH-STREET AMENDED ALIGNMENT BILL").		
<b>CIRCULAR QUAY, PURCHASE OF LAND ADJOINING</b> (See "GOVERNMENT"; also, "PARLIAMENTARY STANDING COMMITTEE ON PUBLIC WORKS").		
<b>CIRCULAR QUAY LAND SALE AND DEDICATION BILL :—</b>		
Message from Governor, 420; motion made ( <i>Mr. Burns</i> ) for Committee of the Whole, 425; House in Committee, resolution agreed, presented and read 1 <sup>o</sup> , 494; read 2 <sup>o</sup> , committed, 544; reported with amendments, 549; report adopted, 561; read 3 <sup>o</sup> , passed, and sent to Council, 567; returned with an amendment, 613; amendment agreed to, 626; assent reported, 629.	3	1019
<b>CITIES, TOWNS, AND VILLAGES</b> (See "CROWN LANDS").		
<b>CITY OF SYDNEY IMPROVEMENT BOARD :—</b>		
Annual Report of, for year ended August, 1887, laid on Table, 112 .....	2	269
<b>CITY OF SYDNEY MAYORAL ELECTION BILL :—</b>		
Motion made ( <i>Mr. O'Connor</i> ) for leave to bring in, presented and read 1 <sup>o</sup> , 236; Order of the Day postponed, 349, 508.		

REFERENCES TO THE VOTES AND PROCEEDINGS, VOL. I—13TH PARLIAMENT—SESSION, 1887-8.	PAPERS.
	VOL. PAGE.
<b>C</b>	
CIVIL SERVICE (See also "VOTE OF CENSURE") :—	
ACT :—	
Motion made ( <i>Mr. Frank Farnell</i> ) for a statement showing retirements under clauses 43, 44, 46, and 47, gratuities to officers whose services have been dispensed with under clauses 48, 49, and 50, amount chargeable to Superannuation Account, giving each officer's gratuity, with particulars of all cases where officer's services have been dispensed with, 22; Return to Order, laid on Table, 112.	2 79
Motion made ( <i>Mr. Waddell</i> ) for alteration of provisions in reference to allowances and gratuities, and by leave withdrawn, 433.	
APPOINTMENTS TO :—	
Return ( <i>in part</i> ) to Order ( <i>Second Session, 1887</i> ) laid on Table, 6.	2 85
DEPARTMENT OF PUBLIC WORKS :—	
Information respecting officers in, and Permanent-way men on the Railways, laid on Table, 28.	8 1053
Papers in connection with appointment of Mr. Joseph Barling to the position of Chief Clerk in the Ministerial Branch of, laid on Table, 144.	2 99
APPOINTMENTS MADE IN THE RAILWAY DEPARTMENT :—	
Motion made ( <i>Mr. Lyne</i> ) for a return showing permanent and temporary since 1st January, 1887, 40; Return to Order, laid on Table, 231.	2 97
SALARIES OF CIVIL SERVANTS :—	
Motion made ( <i>Mr. McElhone</i> ), that the payment of increases in the salaries proposed by the Stuart Government and sanctioned by Parliament, and continued to the present time, ought to cease, and the salaries revert to the rate paid prior to the granting of the increases, and that effect be given to this resolution in the Estimates for 1888 and negatived, 58.	
EXAMINERS OF TITLES AND REGISTRAR-GENERAL :—	
Particulars respecting the office-hours, &c., of, laid on Table, 63.	2 115
EXAMINERS OF TITLES UNDER REAL PROPERTY ACT :—	
Motion made ( <i>Mr. J. P. Abbott</i> ) for return showing work done by Mr. Burton and the others, 70; Return to Order, laid on Table, 112.	2 117
GRATUITIES AND RETIRING ALLOWANCES :—	
Motion made ( <i>Mr. Frank Farnell</i> ) for a comparative return showing amounts voted and paid each year out of Consolidated Revenue Fund for ten years prior to the passing and since the passing of the Act of 1884, 106.	
FEES RECEIVED BY CIVIL SERVANTS :—	
Return ( <i>in part</i> ) to Order ( <i>Second Session, 1887</i> ) laid on Table, 191.	2 103
Further Return to Order, laid on Table, 257.	2 109
MR. G. H. EMERY, LATE LAND AGENT AT QUEANBEYAN :—	
Motion made ( <i>Mr. O'Sullivan</i> ) for all papers, &c., in connection with recent removal of, 215; Return to Order, laid on Table (not printed), 304.	
CHARGES MADE AGAINST EXAMINER OF COAL-FIELDS :—	
Report laid on Table, 273.	8 217
OVERTIME TO OFFICERS :—	
Statement showing amounts in Department of Lands during 1887, laid on Table, 277.	5 97
CORRESPONDENCE, RECORD, AND MAIL BRANCHES, GENERAL POST OFFICE :—	
Return showing names and length of service of Officers employed in, laid on Table, 324.	4 979
MR. LEOPOLD YATES, ACTING STIPENDIARY MAGISTRATE :—	
Information respecting, laid on Table (not printed), 378.	
MESSRS. ADDISON, O'MALLEY CLARKE, AND MR. T. K. ABBOTT, STIPENDIARY MAGISTRATES :—	
Return showing Number and Nature of Complaint against, laid on Table (not printed), 378.	
MR. J. M. BEATTY :—	
Petition from, submitting statement of his public services and praying for consideration of his case, 468.	2 141
BOARD :—	
Annual Report for 1887, laid on Table.	2 69
HARBOURS AND RIVERS DEPARTMENT :—	
Motion made ( <i>Mr. Frank Farnell</i> ) for a return of officers, their length of service and rate of pay, and the number of articulated pupils and their rates of pay, 500.	
ASSISTANT EXAMINER OF ACCOUNTS, TREASURY :—	
Return respecting applications for position of, laid on Table, 524.	2 111
DEPARTMENT OF PUBLIC INSTRUCTION :—	
Information respecting persons employed in, who have attained the age of sixty years, laid on Table, 635.	4 487
CLARENCE TOWN :—	
CLARENCE, THE (See "ELECTORAL").	
CLARENCE RIVER (See also "PARLIAMENTARY STANDING COMMITTEE ON PUBLIC WORKS") :—	
Report by Sir John Coode on the Entrance to, laid on Table, 475.	3 899
CLARENCE TOWN :—	
REMOVAL OF TIMBER FROM CROWN LANDS :—	
Motion made ( <i>Mr. Creer</i> ) for papers, 335; Return to Order laid on Table, 385.	5 499
CLARKE, MR. O'MALLEY, STIPENDIARY MAGISTRATE :—	
Return showing number and nature of complaints made against Stipendiary Magistrates, laid on Table, 378.	
CLASSIFICATION OF TEACHERS (See "EDUCATION").	
CLERK OF ASSEMBLY :—	
Reads Proclamation convening Parliament, 1.	
Reads Address in Reply, 3.	
Reads Petition, 76, 84, 88, 127, 145, 218, 246, 252, 294, 303, 345, 352, 421, 437, 454, 492, 496, 505, 519, 543, 565, 579, 635.	
Reads Documents, 520.	
Reads Report from Committee of Elections and Qualifications, 55, 296.	
Reads Deputy Speaker's Commission to administer the Oath of Allegiance, 19.	
Reads letter from Mr. P. J. Hourigan, requesting name of Solicitor who will accept service on behalf of Mr. Speaker, of writ issued at instance of T. M. Slattery, Esq., M.P., 228.	
Reads entry in Votes and Proceedings of Order of Leave for the introduction of a Bill, 246, 349.	
Reads Statement in Speech made by Mr. Haynes, M.P., reported in the <i>Australian Star</i> , 364.	
Summoned to produce records, 89, 351.	
Swears Members of Elections and Qualifications Committee, 37 (7), 287.	
Lays on Table Minutes of Proceedings and Evidence taken before Select Committee of a previous Session, 71, 115, 140.	
Obtains leave to return documents handed in before Select Committee, 88, 468.	

REFERENCES TO THE VOTES AND PROCEEDINGS, VOL. I—13TH PARLIAMENT—SESSION, 1887-8.	PAPERS.	
	VOL.	PAGE.
<b>C</b>		
CLERK OF ASSEMBLY—(continued) :—		
Reports non-return to his custody of Records of the House, by a Member who had had the use of them, 51; motion of <i>Privilege</i> moved in reference to—Records returned—and motion by leave withdrawn, 53.		
Retirement of Mr. Jones from position of, 250.		
Commission appointing Mr. Frederick William Webb to be Clerk of the Assembly produced, and Mr. Webb sworn, 285.		
CLOSURE OF DEBATE :—		
Motion made "That Question be now put," and passed, 24 (°), 156, 220, 221, 222, 468, 485.		
Do do do and withdrawn, 156-7.		
Do do do and negatived, 493, 530.		
Do do do and Tellers Lists showing less than forty Members in favour of, 468.		
Ruling of Mr. Speaker that when there are no voices for the Noes, and he is satisfied that forty Members are present, it is not necessary to take a Division, 24; dissent from ruling moved ( <i>Mr. Dibbs</i> ) and negatived, 25.		
COAL-FIELDS (See "MINING").		
COAL-FIELDS REGULATION ACT :—		
Correspondence relating to alleged Breaches of, at Duckenfield Colliery, laid on Table, 252 .....	8	343
COAL SUPPLY :—		
GREAT NORTHERN RAILWAY :—		
Motion made ( <i>Mr. McElhone</i> ) for papers &c. in reference to contracts of Messrs. Reid and Longworth and offer of Mr. Nowland at lower price, 352. Return to Order, laid on Table, 505 .....	6	673
COAST DEFENCES (See "DEFENCES").		
COAST HOSPITAL, LITTLE BAY :—		
Report for 1887 laid on Table, 479 .....	4	599
Report of Board of Health on Treatment of Typhoid Fever at, laid on Table, 608 .....	2	235
COBAR (See "RAILWAYS").		
COCHRAN, CAPTAIN JOHN FOSTER :—		
Motion made ( <i>Mr. Neild</i> ) for all papers, &c., in reference to estate of the late, 506; Return to Order, laid on Table, 543 .....	8	1065
COCKATOO ISLAND :—		
Correspondence respecting the sanitary condition of, laid on Table, 6 .....	2	243
COINAGE :—		
JUBILEE :—		
Despatch respecting, laid on Table, 5, 356 .....	2	1219, 1221
COLLEGE (See "AGRICULTURAL COLLEGE").		
COLLIERIES (See "MINING").		
COLONIAL CONFERENCE IN LONDON, 1887 :—		
Proceedings of,—Vol. 1, laid on Table (not printed), 6.		
Do Vol. 2 (Appendix), Papers laid before the Conference, laid on Table (not printed), 6.		
Proceedings of,—Papers laid before the Conference, laid on Table (not printed), 6.		
COLONY OF AUSTRALIA BILL :—		
Motion made ( <i>Sir Henry Parkes</i> ) for leave to bring in, 175; presented and read 1 <sup>o</sup> , 176.		
COLONY OF NEW SOUTH WALES :—		
Statistical view of progress of since separation of Queensland in 1859 to 1887, laid on Table, 462...	7	1395
COLO VALLEY RAILWAY SURVEY :—		
Motion made ( <i>Mr. Frank Farnell</i> ) for papers, &c., 303; Returns ( <i>in part</i> ) to Order, laid on Table, 348, 352 .....	6	1047, 1067
COMBINATION TRUCKS (See "RAILWAYS").		
COMMERCE AND TRADE (See "STATISTICS").		
COMMISSION (See also "ADELAIDE JUBILEE INTERNATIONAL EXHIBITION").		
Deputy Speaker's ( <i>Mr. Cameron</i> ) to administer the Oath, 19.		
Appointing Frederick William Webb, Clerk of Assembly, 285.		
INTOXICATING DRINK INQUIRY :—		
Report ( <i>First Part</i> ), with Minutes of Evidence and Appendices, laid on Table, 6 .....	7	1
APPOINTMENT OF, TO OPEN FOREIGN MARKETS FOR WOOL AND MEAT :—		
Motion made ( <i>Mr. Waddell</i> ) for, 129, and negatived, 130.		
WATER CONSERVATION :—		
Motion made ( <i>Dr. Ross</i> ) for all correspondence, vouchers, &c., relating to expenditure by the recently expired, 155; Return ( <i>in part</i> ) to Order, laid on Table, 565 .....	5	829
COMMISSIONS TO PROSECUTE FOR THE CROWN :—		
Motion made ( <i>Mr. McElhone</i> ) for return showing particulars respecting, 437; Return to Order, laid on Table, 462 .....	2	623
COMMITTEE OF ELECTIONS AND QUALIFICATIONS (See "ELECTORAL").		
COMMON LODGING-HOUSES BILL :—		
Motion made ( <i>Mr. Cameron</i> ) for Committee of the Whole, 64; Order of the Day postponed, 113; discharged, 325.		
COMMONS :—		
FIELD OF MARS :—		
Return to Order ( <i>Second Session of 1887</i> ) laid on Table, 103 .....	5	823
MUSWELLBROOK :—		
Motion made ( <i>Mr. J. P. Abbott</i> ) for papers in reference to dedication of land for, 500.		
COMMONS ACTS :—		
Regulations under, laid on Table, 6 .....	5	825
COMPANIES BILL :—		
Motion made ( <i>Mr. J. P. Abbott</i> ) for leave to bring in, 378; presented and read 1 <sup>o</sup> , 385; read 2 <sup>o</sup> , committed, reported without amendment, report adopted, 506; read 3 <sup>o</sup> , passed, sent to Council, 512; returned with an amendment, 594; amendment agreed to, 628; Assent reported, 630.		
CONCILIATION (See "TRADES CONCILIATION BILL").		
CONDITIONAL PURCHASES (See "CROWN LANDS"; also "MINING"; also "CONVERSION TO MINING CONDITIONAL PURCHASES VALIDATING BILL"; also "CROWN LANDS PURCHASES VALIDATION BILL").		
CONDOLLENCE (See "ADDRESS").		
CONFERENCE (See "POSTAL"; also "CHINESE").		
CONNOLLY, MR. J. F. :—		
APPLICATION TO MINE IN PARISH OF CURRAFONG :—		
Motion made ( <i>Mr Stokes</i> ) for all correspondence in reference to, between 1884 and 1887, 118; Return to Order, laid on Table, 294 .....	8	349

REFERENCES TO THE VOTES AND PROCEEDINGS, VOL. I—13TH PARLIAMENT—SESSION, 1887-8.		PAPERS.			
<b>C</b>		VOL.	PAGE.		
<b>CONSERVATION OF WATER :—</b>					
LAKE CUDGELLICO AND THE LOWER LACHLAN RIVER :—					
Motion made ( <i>Mr. Gormly</i> ) for Construction of Works, 560.					
COMMISSION :—					
Motion made ( <i>Dr. Ross</i> ) for all correspondence, vouchers, &c., relating to expenditure by, 155;					
Return ( <i>in part</i> ) to Order, laid on Table, 565 .....				5	829
<b>CONSOLIDATED REVENUE (See also "FINANCE").</b>					
Statement of the Fund for 1888, laid on Table, 219 .....				3	497
<b>CONSOLIDATED REVENUE FUND BILL :—</b>					
Motion made ( <i>Mr. Burns</i> ) that suspension of certain Standing Orders is of urgent and pressing necessity; Standing Orders suspended; Messages from Governor, 241; ordered, presented, read 1 <sup>o</sup> , 2 <sup>o</sup> , committed, reported without amendment, report adopted, read 3 <sup>o</sup> , passed and sent to Council, 242; returned without amendment, 247; Assent reported, 250.					
<b>CONSOLIDATED REVENUE FUND BILL (No. 2) :—</b>					
Message (Vote of Credit), 285; Standing Orders suspended, ordered, presented, and read 1 <sup>o</sup> , 2 <sup>o</sup> ; read 2 <sup>o</sup> , committed, reported without amendment, report adopted, read 3 <sup>o</sup> , passed and sent to Council, 296; returned without amendment, 309; Assent reported, 311.					
<b>CONSOLIDATED REVENUE FUND BILL (No. 3.) :—</b>					
Motion made ( <i>Mr. Burns</i> ) for suspension of Standing Orders, 344; Message from Governor 345; ordered, presented, and read 1 <sup>o</sup> , 2 <sup>o</sup> , committed, reported without amendment, report adopted, read 3 <sup>o</sup> , passed and sent to Council, 346; returned without amendment, 349; Assent reported 351.					
<b>CONSOLIDATED REVENUE FUND BILL (No. 4) :—</b>					
Message (Vote of Credit), 404; Standing Orders suspended, ordered, presented, and read 1 <sup>o</sup> , 2 <sup>o</sup> committed, reported without amendment, report adopted, read 3 <sup>o</sup> , passed and sent to Council, 409; returned without amendment, 416; Assent reported, 419.					
<b>CONSOLIDATED REVENUE FUND BILL (No. 5) :—</b>					
Message (Vote of Credit) 477; Standing Orders suspended, 479; ordered, presented, read 1 <sup>o</sup> , 2 <sup>o</sup> , committed, reported without amendment, report adopted, read 3 <sup>o</sup> , passed and sent to Council, 481; returned without amendment, 486; Assent reported, 491.					
<b>CONSOLIDATED REVENUE FUND BILL (No. 6) :—</b>					
Motion made ( <i>Mr. Burns</i> ) for suspension of Standing Orders, Message from Governor, 553; ordered, presented, read 1 <sup>o</sup> , 2 <sup>o</sup> ; committed, reported without amendment, report adopted, read 3 <sup>o</sup> , passed and sent to Council, returned without amendment, 554; Assent reported, 555.					
<b>CONSTITUTION-ACT AMENDMENT (See "MINISTERIAL ELECTION BILL").</b>					
<b>CONTAGIOUS DISEASES PREVENTION BILL :—</b>					
Motion made ( <i>Mr. Frank Farnell</i> ) for Committee of the Whole, 64; Order of the Day postponed, 107, 145, Discharged; 252.					
<b>CONTEMPT :—</b>					
Motion made adjudging a member guilty of, 156 (?).					
<b>CONTRACTORS (See "RAILWAYS").</b>					
<b>CONTRACTORS DEBTS ACT EXTENSION BILL :—</b>					
Motion made ( <i>Mr. Carruthers</i> ) for Committee of the Whole, 52; Order of the Day postponed, 65, 107, 131, 288; House in Committee; resolution agreed to, 321; presented and read 1 <sup>o</sup> 342; Order of the Day postponed, 416; read 2 <sup>o</sup> , committed, reported without amendment, report adopted, 507; read 3 <sup>o</sup> , passed and sent to Council, 513; returned without amendment, 547; Assent reported, 555.					
<b>CONTRACTS FOR LOCOMOTIVES (See "RAILWAYS").</b>					
<b>CONTRACTS OF CHARLES KIDMAN AND SONS AND JAMES KIDMAN :—</b>					
Statement of Amount of Money paid under, from 1876 to 1887, laid on Table (not printed), 403					
<b>CONVERSION INTO MINING CONDITIONAL PURCHASES VALIDATION BILL :—</b>					
Motion made ( <i>Mr. Garrett</i> ) for leave to bring in, 231; presented and read 1 <sup>o</sup> , 236; read 2 <sup>o</sup> , committed, reported with amendments, report adopted, 258; read 3 <sup>o</sup> , passed, and sent to Council, 263; returned with an amendment, 281; amendment agreed to, 309; Assent reported, 317.					
<b>CONVEYANCERS (See "ATTORNEYS BILLS OF COSTS AND PRACTICE OF CONVEYANCING AMENDMENT BILL").</b>					
<b>CONVICTIONS UNDER THE LICENSING ACT :—</b>					
Motion made ( <i>Mr. Henson</i> ) for additional information respecting, 506.					
<b>SPIRITS, WINES, AND BEER :—</b>					
Annual Return to Order laid on Table, 560 .....				7	681
<b>CONWAY, C. J. :—</b>					
CLAIM OF :—					
Motion made ( <i>Mr. Waddell</i> ) for Select Committee to inquire into and report upon, and withdrawn, 237.					
<b>COODE, SIR JOHN, K.C.M.G., M.I.C.E. :—</b>					
Report (with plans) upon Lake Macquarie Harbour Works, laid on Table, 324 .....				3	895
Report on Entrance to Richmond River, laid on Table, 462 .....				3	905
Report on the Entrance to Clarence River, laid on Table, 475 .....				3	899
<b>COOLA CREEK (See "EDUCATION").</b>					
<b>COOLE, TICKET-COLLECTOR EDWARD (See "RAILWAYS").</b>					
<b>COOMA (See "ROADS"; also "RAILWAYS").</b>					
<b>COOMA CHURCH OF ENGLAND LANDS SALE BILL :—</b>					
Petition presented ( <i>Mr. Day</i> ) for leave to bring in, 523; leave given; presented and read 1 <sup>o</sup> , 529; referred to Select Committee, 537; Report brought up, 547; Order of the Day postponed, 585; read 2 <sup>o</sup> , committed, reported with amendments, report adopted, 599; read 3 <sup>o</sup> , passed, and sent to Council, 602; returned with amendments, 639; amendments agreed to, 641; assented to in Council Chamber, 642.					
<b>COOMBING (See "RAILWAYS").</b>					
<b>COPELAND ATS. NASH (See "RAILWAYS").</b>					
<b>COPYRIGHT LAWS OF GREAT BRITAIN :—</b>					
Correspondence respecting infringement of, laid on Table, 181 .....				8	1047
<b>CORK, ROBERT, CASE OF (See "CROWN LANDS PURCHASES VALIDATION BILL").</b>					
<b>CORKERY, DANIEL (See "RAILWAYS").</b>					
<b>COROWA :—</b>					
LATE ACTING POLICE MAGISTRATE :—					
Return to Order ( <i>Second Session 1887</i> ) laid on Table (not printed), 144.					
Further Return to Order ( <i>Second Session 1887</i> ) laid on Table, 389; Ordered to be printed, 454...					
<b>CORPORATION ACT AMENDMENT BILL (See "SYDNEY CORPORATION ACT AMENDMENT BILL").</b>				2	631

REFERENCES TO THE VOTES AND PROCEEDINGS, VOL. I—13TH PARLIAMENT—SESSION, 1887-8.	PAPERS.	
	VOL.	PAGE.
<b>C</b>		
CORPORATION OF THE CITY OF SYDNEY :— Statement of Receipts and Expenditure for 1885, 1886, and 1887 respectively, laid on Table, 429...	2	255
CORRESPONDENCE (See "POSTAL") :—		
COUNCIL (See "LEGISLATIVE COUNCIL").		
COUNSEL'S FEES (See "ATTORNEY-GENERAL").		
COUNT-OUT (See "NO QUORUM").		
COUNTRY TOWNS WATER AND SEWERAGE ACT (See also "BY-LAWS") :—		
NOTIFICATIONS UNDER, LAID UPON THE TABLE :—		
Authorizing the construction of Water Supply Works for the town of Balranald, 6 .....	5	881
Completion of the Water Supply Works for the town of Wentworth, 475 .....	5	885
Completion of the Water Supply Works for the town of Bourke, 475 .....	5	883
COUNTRY TOWNS WATER AND SEWERAGE ACT EXTENSION BILL :—		
Motion made ( <i>Sir Henry Parkes</i> ) for Committee of the Whole, 64; House in Committee, Resolution agreed to, presented and read 1 <sup>o</sup> , 70; read 2 <sup>o</sup> , committed, reported without amendment, and report adopted, 104; read 3 <sup>o</sup> , passed, and sent to Council, 112; returned without amendment, 177; assent reported, 219.		
COWRA (See "RAILWAYS").		
COYLE, ROBERT :—		
Motion made ( <i>Mr. Walker</i> ) for Select Committee to inquire into treatment of, whilst a prisoner in Berrima and other gaols, and debate interrupted by Government Business, 123; Order of the Day postponed, 131; Order of the Day discharged, 252.		
CRAWFORD, RAILWAY TRAFFIC INSPECTOR (See "RAILWAYS").		
CREDITORS REMEDIES (See "JUDGMENT CREDITORS REMEDIES EXTENSION BILL").		
CREER, MR.		
A MEMBER FOR NORTHUMBERLAND :—		
Declared guilty of persistent disorder and removed, by the Sergeant-at-Arms, from the Chamber, 221.		
CREMATION BILL :—		
Motion made ( <i>Mr. Trickett</i> ) for Committee of the Whole, 53; Order of the Day discharged, 77.		
Motion made ( <i>Mr. Trickett</i> ) for leave to bring in, presented and read 1 <sup>o</sup> , 185.		
Petition in favour of, from David Buchanan, Barrister-at-Law, presented, 272 .....	8	1049
CRICKET GROUND (See "ASSOCIATION CRICKET GROUND").		
CRIME AND CIVIL JUSTICE (See "STATISTICS").		
CRIMINALS (See "FUGITIVE CRIMINALS").		
CRIMINAL LAW AMENDMENT BILL :—		
Received from Legislative Council, and on motion of ( <i>Mr. William Clarke</i> ) read 1 <sup>o</sup> , 430; read 2 <sup>o</sup> , committed, reported without amendment, report adopted, 536; read 3 <sup>o</sup> , passed, returned to Council, 598; Assent reported, 626.		
CROWN LANDS (See also "CROWN LANDS PURCHASES VALIDATION BILL"; also "CROWN LANDS BILL"; also "RESERVES") :—		
ALTERATIONS OF DESIGNS OF CITIES, TOWNS, AND VILLAGES :—		
Abstract of, laid on Table, 5, 97, 150, 210, 263, 326, 360, 442, 547, 634 .....	5	629 to 647
SITES FOR CITIES, TOWNS, AND VILLAGES :—		
Abstract of, laid on Table, 5, 97, 150, 210, 263, 326, 360, 442, 484, 547, 634 .....	5	743 to 763
RESERVED FOR PRESERVATION OF WATER SUPPLY :—		
Abstract of, laid on Table, 5, 97, 151, 209, 263, 326, 360, 442, 484, 547, 634 .....	5	701 to 741
DEDICATED TO PUBLIC PURPOSES :—		
Abstract of, laid on Table, 5, 97, 112, 151, 209, 263, 326, 360, 442, 484, 547, 634 .....	5	649 to 671
DEDICATED TO RELIGIOUS PURPOSES :—		
Abstract of, laid on Table, 5 .....	5	673
DEDICATION OF CERTAIN LANDS UNDER 105 SEC. :—		
Gazette Notices respecting, laid on Table, 5, 97, 210, 326, 344, 360, 441, 484, 547, 634 .....	5	675 to 699
REGULATIONS :—		
Under Act of 1884, laid on Table, 40 (?), 155, 199, 267, 302, 360, 429, 613 ..	5	581 to 597
Under Act of 1884, notifications of cancellation, laid on Table, 360 .....	5	595
DEPARTMENT :—		
Report for 1886 laid on table, 257 .....	5	1
Statement showing overtime to officers for 1887, laid on Table, 277 .....	5	97
VOLUNTEER LAND ORDERS :—		
Motion made ( <i>Mr. Crouch</i> ) for a return showing number issued, number made use of, specifying the number used in each Land District, 12; Return to Order, laid on Table, 168 .....	2	31
RENTS ON CROWN LEASES :—		
Motion made ( <i>Mr. Lee</i> ) for a return showing rents recommended by Local Land Boards on each pastoral, homestead, and conditional lease, and occupation license, the minimum rental on same, and rental fixed by Minister, 22; Return ( <i>in part</i> ) to Order, laid on Table, 84 .....	5	171
ALBURY AND WAGGA WAGGA OFFICES :—		
Motion made ( <i>Mr. Day</i> ) for all papers, reports, &c., sent in by the Board appointed to inquire into the working of, 23.		
ALBURY TO WAGGA WAGGA, REMOVAL OF SURVEY OFFICES FROM :—		
Motion made ( <i>Mr. Day</i> ) for all papers, reports, telegrams, and recommendations respecting, 41; Return to Order, laid on Table, 476 .....	5	101
EVAN McINTOSH'S CONDITIONAL PURCHASE AT CURRABUBULA :—		
Motion made ( <i>Mr. Levien</i> ) for a Select Committee on, which was afterwards transferred to Daniel Regan, Esq., and that evidence and papers produced before the Select Committee in Session 1885-6 be referred, 36.		
GRAFTON AND THE CLARENCE ELECTORATES :—		
Motion made ( <i>Mr. See</i> ) for a return showing entire revenue from all sources since 1861, 128.		
MRS. ANN ROUSE'S CONDITIONAL PURCHASE AT KAHIBAH :—		
Motion made ( <i>Mr. J. P. Abbott</i> ) for all papers relating to 80 acres made at Newcastle on 20th July, 1871, also on 4th February, 1875, and all reports on and surveys of the land, with plans and descriptions of any reserves by which the said 80 acres of land was affected, 41; Return to Order, laid on Table, 208; referred to Select Committee, 389 .....	5	277
Motion made ( <i>Mr. J. P. Abbott</i> ) for Select Committee to inquire into circumstances of, 89; papers referred to Committee, 389; report brought up, 496 .....	5	265
CURRAGUNDI RUN :—		
Motion made ( <i>Mr. Frank Farnell</i> ) for all papers, plans, &c., in connection with the pastoral holding of, Gwydir District, 48; Return to Order, laid on Table, 208 .....	5	251
Petition of Mr. George Robert Edward Fergusson, that he entered into possession of a conditional purchase, and an action was brought against him by Mr. G. M. Pitt, by which he incurred serious expense and losses, and praying relief, presented, 277 .....	5	263



REFERENCES TO THE VOTES AND PROCEEDINGS, VOL. I—13TH PARLIAMENT—SESSION, 1887-8.	PAPERS.
	VOL. PAGE.
<b>C</b>	
<b>CROWN LANDS—(continued) :—</b>	
<b>G. M. PITT'S, JUNR.—BUNABA NORTH AND CURRAGUNDI STATIONS :—</b>	
Petition from George Matcham Pitt, junior, that in 1884 on the passing of the present Act he was the owner of, and that by the division of the said stations injustice has been done him, and he has suffered pecuniary loss, and praying relief, presented, 144; motion made ( <i>Mr. Bowman</i> ), for Select Committee, 232; report brought up, 416 .....	5 485
<b>THOMAS THOMPSON'S CONDITIONAL PURCHASE, MADE AT MOAMA :—</b>	
Motion made ( <i>Mr. Chanter</i> ) that a Select Committee be appointed, and that Progress Report, evidence, &c., of last Session be referred, 53; Report brought up, 200; adoption of Report negatived, 433 .....	5 207
<b>SALE OF CERTAIN LAND, PARISH OF MOLONG, COUNTY OF ASHBURNHAM :—</b>	
Motion made ( <i>Dr. Ross</i> ) for Address to Governor, for copies of correspondence, plans, &c., and the Judge's decision and ruling, 479.	
<b>JOHN TIERNEY'S CONDITIONAL PURCHASE :—</b>	
Motion made ( <i>Mr. Wall</i> ) for Select Committee to inquire into refusal by Mines Department of the application to mine on, under the 7th section of the Act, 59.	
<b>WILLIAM SKENE'S PRE-LEASE AT CONARGO :—</b>	
Motion made ( <i>Mr. Chanter</i> ) for all papers, correspondence, &c., in relation to, 60, 320; Return to Order, laid on Table, 298; Return to Order, laid on Table, 634.....	5 217, 233
<b>RINGBARKING :—</b>	
Motion made ( <i>Dr. Ross</i> ) for Return showing area and list of runs on which permission had been granted since 31st March, 1881, 325; Return to Order, laid on Table, 613 .....	5 507
<b>CONDITIONAL PURCHASES OF JAMES C. STEVENSON :—</b>	
Motion made ( <i>Mr. J. P. Abbott</i> ) for copies of all papers relating to, 325; Return to Order, laid on Table, 432 .....	5 325
<b>REMOVAL OF TIMBER FROM, NEAR CLARENCE TOWN :—</b>	
Motion made ( <i>Mr. Creer</i> ), for papers, 335; Return to Order, laid on Table, 385 .....	5 499
<b>CONDITIONAL PURCHASE OF ZACHARY BENN :—</b>	
Motion made ( <i>Mr. Crouch</i> ) for papers in the case of, 341; Return to Order, laid on Table, 429.....	5 311
<b>CONDITIONAL PURCHASE CASE—GEORGE MILLGATE v. The Honorable JOHN SMITH :—</b>	
Motion made ( <i>Dr. Ross</i> ) for further correspondence, reports &c., since that laid on Table in March, 1884, 64; Further Return to Order, laid on Table, 277.....	5 343
<b>THE LAND LAWS :—</b>	
Petition referring to present mode of determining the rents of pastoral leases, presented, 76.....	5 619
Petition referring to operation of, and praying that certain amendments be made in Bill now before House, presented, 88, 218, 294.....	5 621 to 625
Petition referring to action of Minister for Lands in fixing rents, and stating that the raising of the rents had depreciated the value of pastoral securities, presented, 352.....	5 627
<b>FORFEITED CONDITIONAL PURCHASES WITHIN LEASEHOLD AREAS :—</b>	
Motion made ( <i>Mr. J. P. Abbott</i> ), for Address to the Governor. That as the Privy Council had in the case <i>Edols v. Tearle</i> affirmed that the land was open to conditional purchase, this House is of opinion that such should at once be thrown open for conditional purchase, 353.	
<b>SELECTIONS BY JOHN HARRISON, OF LISMORE :—</b>	
Motion made ( <i>Mr. Ewing</i> ), for papers in reference to forfeiture of, 357; Return to Order, laid on Table, 462.....	5 447
<b>CLAIM OF CORNELIUS GRADY :—</b>	
Leave given to Clerk to return to Lands Department papers produced before the Select Committee of last Session on the subject, 88.	
<b>PARRY'S CONDITIONAL PURCHASES ON CURRUGUNDI AND WARREN SOUTH RUNS :—</b>	
Motion made ( <i>Mr. Hassall</i> ) for a Select Committee to inquire into, 130; Report brought up, 487...	5 239
<b>SECTION 4, CROWN LANDS ALIENATION ACT OF 1861 :—</b>	
Opinion of Mr. Attorney-General Dalley respecting the application of, to the reservation of large areas from sale for mining purposes, laid on Table, 500 .....	5 109
<b>CONDITIONAL PURCHASES MADE BY MR. AND MRS. POOLE, MESSRS PARNELL, AND THE MISSES PARNELL :—</b>	
Motion made ( <i>Mr. McElhone</i> ) for papers in connection with, 500; Return to Order, laid on Table, 634.....	5 355
<b>COMMON FOR MUSWELLBROOK :—</b>	
Motion made ( <i>Mr. J. P. Abbott</i> ) for papers relating to dedication, 500.	
<b>CONDITIONAL PURCHASE MADE BY MARY MALONEY AT BURROWA :—</b>	
Motion made ( <i>Mr. Vaughn</i> ) for papers in connection with, 546.	
<b>SELECTION MADE BY GEORGE FOSTER AT COROWA :—</b>	
Motion made ( <i>Mr. J. P. Abbott</i> ) for papers in connection with, 546.	
<b>QUIT RENTS :—</b>	
Return to Order (Session 1887), laid on Table, 559 .....	5 195
<b>FENCING PROVISIONS OF THE LAND LAW :—</b>	
Adjournment moved to call attention to necessity of immediate legislation in regard to, 595.	
<b>ROBERT MACKRELL'S CONDITIONAL PURCHASE AT FORBES :—</b>	
Motion made ( <i>Mr. Vaughn</i> ) for a Select Committee to inquire into, and that Proceedings and Evidence of previous Session, laid on Table to be referred, 130; Proceedings, &c., laid on Table and referred to Select Committee, 140. Report brought up, 342 .....	5 285
Petition from E. H. Moulder of Wardry Station, that he is interested in, and praying to be heard by Counsel or Agent before the Select Committee, presented, and prayer of Petitioner granted, 181.....	5 309
<b>JOACHIM FAMILY :—</b>	
Petition from, that they came to Colony in 1873, and conditionally purchased land near Moama, that on alleged grounds of non-residence and others, they were subjected to severe litigation, and that their title has not been recognised by the Crown, presented, and referred to Select Committee on Crown Lands Purchases Validation Bill, 135 .....	5 559
Papers (Session 1873-4) in reference to Conditional Purchases of, referred to Select Committee on Crown Lands Purchases Validation Bill, 161.	
<b>MEASURED FOR SALE AT FITZROY WATERFALL :—</b>	
Plan of forty-five portions, situate near the village of Yarrunga, laid on Table, 228 .....	5 201
<b>ROBERT MUNFORD'S CONDITIONAL PURCHASES MADE AT MOLONG :—</b>	
Motion made ( <i>Dr. Ross</i> ) for a Select Committee to inquire into and report upon, 237.	
Motion made ( <i>Dr. Ross</i> ) to refer Return to Order (Session 1887), 277.	
<b>MR. G. H. EMBERY, LATE LAND AGENT AT QUEANBEYAN :—</b>	
Motion made ( <i>Mr. O'Sullivan</i> ) for all papers, &c., in connection with the recent removal of, 215; Return to Order laid on Table (not printed), 304	
<b>CONDITIONAL PURCHASES :—</b>	
Motion made ( <i>Dr. Ross</i> ) for a return showing the number made in each District from 1881 to date, the total area, and the number transferred, 150, 416; Return to Order, laid on Table, 429.....	5 199

REFERENCES TO THE VOTES AND PROCEEDINGS, VOL. I—13TH PARLIAMENT—SESSION, 1887-8.	PAPERS.
	VOL. PAGE.
<b>C</b>	
<b>CROWN LANDS—(continued) :—</b>	
<b>CLAIM OF ISAAC BARCLAY :—</b>	
Motion made ( <i>Mr. Martin</i> ) for a Select Committee to consider, for compensation for losses sustained in defending his title to land held under Crown Grant, 165. Report brought up, 609.	5 487
<b>ADMINISTRATION OF LAND LAWS BY MINISTER FOR LANDS :—</b>	
Motion made ( <i>Mr. Stokes</i> ) that this House do now adjourn, to call attention to unsatisfactory, put and negatived, 263.	
<b>CLAIM OF CHARLES STEVENS :—</b>	
Report from Select Committee ( <i>Session 1887</i> ), adopted, 268.	
<b>RENTS FOR CROWN LANDS :—</b>	
Motion made ( <i>Mr. O'Sullivan</i> ) for a return of rent received for leasehold areas, occupation licenses, and homestead areas, under Land Act of 1884, 258. Return to Order, laid on Table, 320	5 111
<b>TEARLE V. EDOLS :—</b>	
Motion made ( <i>Mr. J. P. Abbott</i> ) for adjournment of the House to discuss decision of the Privy Council, 287.	
<b>RENTS OF PASTORAL LEASES :—</b>	
Return giving particulars of appeals in connection with, not dealt with by Minister, laid on Table, 415	5 191
<b>SELECTION OF JAMES IRVING, SOUTH YATHONG, URANA :—</b>	
Motion made ( <i>Mr. Lyne</i> ) for papers in connection with, 403.	
<b>RATE OF RENTAL PER ACRE AND LICENSE FEE PER SECTION ON THE WESTERN DIVISION :—</b>	
Return respecting, laid on Table, 408; Return ( <i>in substitution</i> ), 415	5 113
<b>IMPROVEMENTS EFFECTED ON, IN EASTERN, CENTRAL, AND WESTERN DIVISIONS :—</b>	
Return showing value of, laid on Table, 415	5 205
<b>AREA OF LAND ALIENATED, LEASED, AND RETAINED IN EASTERN DIVISION :—</b>	
Approximate return showing, laid on Table, 415	5 203
<b>RENTS AND LICENSE FEES :—</b>	
Return respecting, recommended by Land Boards and fixed by Minister, 415	5 123
<b>LAND BUSINESS, DISTRICTS OF PARKES, FORBES, AND MOLONG :—</b>	
Return respecting, for years 1885, 1886, and 1887, respectively, laid on Table, 580	5 197
<b>REFUND OF ABATEMENTS IN RENTS OF CROWN LESSEES :—</b>	
Adjournment of the House moved in respect to cases where appeal has been made and rent reduced, 586.	
<b>CROWN LANDS ACT FURTHER AMENDMENT BILL (<i>FENCING</i>) :—</b>	
Motion made ( <i>Mr. Garrett</i> ), for Committee of the Whole, 573; Standing Orders suspended, 578; House in Committee, resolution agreed to, 580; presented ( <i>Sir Henry Parkes</i> ), read 1 <sup>o</sup> , 586; read 2 <sup>o</sup> , passed, committed, reported, report adopted, 587; 3 <sup>o</sup> reading moved, and amendment proposed to recommit, and negatived, read 3 <sup>o</sup> , passed, motion made for Message to Council, and amendment moved to add words, and negatived, Message to Council passed, 595; returned without amendment, 626; Assent reported, 630.	
<b>CROWN LANDS ALIENATION ACT OF 1861 (See "CROWN LANDS").</b>	
<b>CROWN LANDS ACT OF 1884 (See "CROWN LANDS").</b>	
<b>CROWN LANDS BILL :—</b>	
Motion made ( <i>Mr. Garrett</i> ) for Committee of the Whole, 35; House in Committee, Resolution agreed to, Message from Governor, 49; presented and read 1 <sup>o</sup> , 65; motion made for 2 <sup>o</sup> and debate adjourned, 99; Order of the Day discharged, and Bill withdrawn, 137	5 599
<b>PETITION PRESENTED :—</b>	
Suggesting certain amendments, 123	5 601
<b>CROWN LANDS BILL (No. 2) :—</b>	
Motion made ( <i>Mr. Garrett</i> ) for Committee of the Whole, 152; House in Committee, 161; Resolution agreed to, Message from Governor, 162; presented and read 1 <sup>o</sup> , 162; motion made for 2 <sup>o</sup> , and debate adjourned, 296, debate resumed, and further adjourned, 308, 315, 326, 335, 338, 349, 357; resumed, read 2 <sup>o</sup> , 361; committed, 362; further considered in Committee, 373, 374, 381, 390, 398, 417, 437, 442.	5 603
<b>PETITION FROM WILLIAM JAMES REID AND THOMAS SHAW :—</b>	
Praying that the 101st clause may be amended, and asking for leave to appear at Bar of the House, presented, 303; and prayer granted, 404	5 607
<b>PETITION OF INHABITANTS OF MOAMA AND SURROUNDING DISTRICTS :—</b>	
Protesting against the Bill and praying that a Bill will be passed enabling the petitioners to obtain portions of land on which to settle, read by the Clerk, 437	5 605
<b>PETITION FROM THE MUNICIPAL COUNCIL OF THE BOROUGH OF ST. LEONARDS :—</b>	
Praying that clauses 84 to 87 be eliminated or amended in the manner indicated, 462	5 609
<b>PETITION SELECTORS OF ADAMINABY AND DISTRICT :—</b>	
Praying the House to consider certain amendments suggested by them, 500	5 611
<b>PETITION OF MUNICIPAL COUNCIL OF MANLY :—</b>	
Praying that clauses 84 to 87 may be eliminated or amended as indicated in the Petition, 505	5 615
<b>PETITION OF RESIDENTS OF THE DISTRICT OF BOGGABRI :—</b>	
Praying that a Court of Appeal should be established, and stating that the present and proposed Courts of Inquiry does not meet with approval, 505	5 613
<b>PETITION OF MAYOR OF BOROUGH OF WEST MAITLAND :—</b>	
Praying the House not to pass the clauses relating to the rescinding reservations of water frontages, 543	5 617
<b>CROWN LANDS PURCHASES VALIDATION BILL :—</b>	
Motion made ( <i>Mr. Garrett</i> ) for leave to bring in, presented and read 1 <sup>o</sup> , 17; motion made for 2 <sup>o</sup> —amendment carried to refer Bill to a Select Committee, 29; report brought up, 468; motion made for 2 <sup>o</sup> ( <i>as amended and agreed to in Select Committee</i> ) and debate adjourned, 494; read 2 <sup>o</sup> , committed, reported with amendments, 544; recommitted, 547; reported with a further amendment, 548; read 3 <sup>o</sup> , passed, and sent to Council, 560; returned with an amendment 594; Order of the Day postponed, 609; Council's amendment agreed to, 627; Assent reported 630.	5 503
<b>PETITIONS REFERRED TO SELECT COMMITTEE :—</b>	
From the Joachim family, 135	5 563
Martin Tully, the younger, 161	5 561
Robert Barclay Wallace and James Robert Miller Robertson, 165.	5 565
Matthew O'Shanassy, 208	5 567
Alexander Rodgers, 215	5 569
John Allen, 232	5 573
Edward Grace, 324	5 571
Stephen Fennell, 328	5 575
Mary Elizabeth Murphy, 403	5 579
Patrick Hogan of Randwick, 451	5

REFERENCES TO THE VOTES AND PROCEEDINGS, VOL. I—13TH PARLIAMENT—SESSION, 1887-8.	PAPERS.	
	VOL.	PAGE.
<b>C</b>		
<b>CROWN LANDS PURCHASES VALIDATION BILL—(continued) :—</b>		
<b>SELECT COMMITTEE :—</b>		
Motion made ( <i>Mr. Garrett</i> ) that the recommendation of the Minister for the validation of certain conditional purchases be referred to the Select Committee on the Bill, 442.		
Applications for validation of Conditional Purchases, referred to Select Committee, 136.		
Papers in reference to Conditional Purchases of the Joachim Family, referred to the Select Committee, 161.		
Motion made ( <i>Mr. Garrett</i> ) that the applications or recommendations for the validation of the auction purchases enumerated therein be referred to the Select Committee sitting on the Bill, 397.		
Motion made ( <i>Mr. Garrett</i> ) that the applications or recommendations for the validation of the conditional purchases enumerated therein be referred to Select Committee sitting on the Bill, 397.		
Name of Mr. Thompson added to, 280.		
<b>CASE OF ROBERT CORK AT MILTON :—</b>		
Papers laid on Table, and referred to Select Committee, 403 ; leave given to clerk to return papers, 468.		
<b>SELECTION OF MICHAEL HERREN :—</b>		
Petition presented ( <i>Mr. Levien</i> ) praying that the case may be referred to the Select Committee, 408.	5	577
<b>CUDGELICO LAKE. (See "CONSERVATION OF WATER").</b>		
<b>CURRAGUNDI RUN (See "CROWN LANDS").</b>		
<b>CUSTOMS :—</b>		
Petition from residents of Broughton Creek, Brogher's Creek, Broughton Vale, and Kangaroo Vale, against the abolition of duties on Farm Produce, presented, 252.	3	881
<b>MR. SWIFT, CUSTOM HOUSE OFFICER, BREWARRINA :—</b>		
Motion made ( <i>Mr. Waddell</i> ) for papers in connection with dismissal of, 369 ; Return to Order laid on Table, 370	2	133
<b>CUSTOMS REGULATION ACT OF 1879 AND CUSTOMS DUTIES ACT OF 1887 :—</b>		
Amended Regulations under, laid on Table, 208	3	865
<b>D</b>		
<b>DAILY "HANSARD" (See "HANSARD").</b>		
<b>DAMS AND WEIRS REGULATION AND REGISTRATION BILL :—</b>		
Motion made ( <i>Mr. J. P. Abbott</i> ) for leave to bring in, 378 ; presented and read 1 <sup>o</sup> , 381 ; Order of the Day discharged and Bill withdrawn, 506.		
<b>DARLING RIVER (See "BRIDGES").</b>		
<b>DAWES POINT (See "LAND").</b>		
<b>DAYSDALE TANK :—</b>		
Notification of resumption under Lands for Public Purposes Acquisition Act, of land in Parish of Gordon, County of Hume, laid on Table, 415	8	951
<b>DEAN, MR. THOMAS (See "EDUCATION").</b>		
<b>DEATH OF HONORABLE MEMBER OF THE LEGISLATIVE ASSEMBLY (See "GIBBES, FREDERICK JAMISON, ESQ.")</b>		
<b>DEATHS UNDER CHLOROFORM :—</b>		
Motion made ( <i>Mr. Withers</i> ) for Return of particulars respecting, 404 ; Return to Order laid on Table, 578.	8	1051
<b>DEBATE (See "ADJOURNMENT").</b>		
<b>DEDICATION OF CERTAIN LANDS (See "CROWN LANDS").</b>		
<b>DEDUCTIONS FROM WAGES OF EMPLOYEES FOR MEDICAL ATTENDANCE :—</b>		
Motion made ( <i>Mr. Walker</i> ) for Select Committee to inquire into practice of contractors, 353 ; Return to Order, "Patients received into Hospitals from Public Works," referred to Committee, 462.		
<b>DEFENCES :—</b>		
Report of Major-General Schaw on, of New South Wales, laid on Table, 199	2	47
<b>COAST AND HARBOUR :—</b>		
Correspondence respecting Major Parrott's report on, laid on Table, 84.	2	63
<b>DEFICIT ACCOUNT (See "FINANCE").</b>		
<b>DENILIQVIN :—</b>		
<b>FIRE BRIGADES BOARD :—</b>		
Report for 1887-8, laid on Table, 452.	2	605
Regulations laid on Table, 634	2	607
<b>DENILIQVIN TRAMWAY BILL (See "HAY AND DENILIQVIN TRAMWAY BILL").</b>		
<b>DEPUTY CHAIRMAN OF COMMITTEES (See "CHAIRMAN OF COMMITTEES").</b>		
<b>DEPUTY SPEAKER :—</b>		
Commission to Angus Cameron, Esquire, to administer the Oath of Allegiance to Members, reported, read by Clerk, 19.		
Takes Chair, 579.		
<b>DESPATCHES :—</b>		
<b>LAI'D ON TABLE :—</b>		
Jubilee Coinage, 5, 356	8	1219, 1221
Foreign Deserter's Act, 1852, 135, 356	8	1181, 1183
Surrender of Fugitive Criminals, 285	8	1281
Trade in Wheat between Australia and Barcelona, 335, 475	8	1309, 1311
Divorce Extension Bill of 1887, 344	8	1061
Position of Chinese in Her Majesty's Dominions, 344	2	221
Authentication of Extradition Papers, 352	8	1067
Applications for certificates of competency as masters and mates, 475	8	1015
Employment of officers of the Royal Navy under Colonial Governments, 475	2	23
Treaty between China and the United States in reference to Chinese Immigration, 529.	2	217
<b>DESTRUCTION OF RABBITS (See "RABBIT PEST").</b>		
<b>DEVONSHIRE-STREET (See "CEMETERY").</b>		
<b>DIAMOND DRILLS (See "MINING").</b>		

REFERENCES TO THE VOTES AND PROCEEDINGS, VOL. I—13TH PARLIAMENT—SESSION, 1887-8.	PAPERS.	
	VOL.	PAGE.
<b>D</b>		
<b>DIBBS, MR. :—</b>		
<b>A MEMBER FOR THE MURRUMBIDGEE :—</b>		
Declared guilty of persistent disorder and removed by Sergeant at Arms from the Chamber, 221.		
<b>PRIVILEGE—GARRETT V. DIBBS :—</b>		
Motion made ( <i>Mr. Dibbs</i> ) That the Crown Solicitor be instructed to defend the action of <i>Garrett v. Dibbs</i> in the interest of the Privileges of this House, 326.		
<b>DIFFERENTIAL RATES</b> (See "RAILWAYS").		
<b>DISCOVERY OF GOLD</b> (See "MINING").		
<b>DISEASES</b> (See "VINE DISEASES ACT AMENDMENT BILL").		
<b>DISEASED ANIMALS AND MEAT BILL :—</b>		
Motion made ( <i>Sir Henry Parkes</i> ) for Committee of the Whole, 537; Message from Governor, 539; House in Committee, 543; resolution agreed to, presented, and read 1 <sup>o</sup> , 544; motion made for 2 <sup>o</sup> , and debate adjourned, 547; Order of the Day postponed, 566; read 2 <sup>o</sup> , committed, 609; Order of the Day postponed, 627.	8	667
<b>DISEASES IN SHEEP AND IMPORTED STOCK ACTS :—</b>		
Regulations under, laid on Table, 257	8	651
<b>DISORDER :—</b>		
Language used reflecting on the Chief Commissioner of Insolvent Estates, now an acting Judge of the Supreme Court, ruled out of order—motion moved to dissent from Mr. Speaker's ruling, and afterwards withdrawn, 49.		
In division—the Honorable Member for Northumberland, Mr. Walker, "named"—motion moved, adjudging him guilty of contempt—bars opened and division lapsed—the Honorable Member for South Sydney, Mr. Toohey, "named," motion made adjudging him guilty of contempt, and committing him to the custody of Sergeant-at-Arms, and Speaker having ruled that the motion was in order, motion made to dissent from ruling, 156; and negatived, and Mr. Toohey, having apologized, motion of contempt withdrawn, 157.		
Use of Language by Mr. Melville, one of the Members for Northumberland, not having been apologized for, when called upon by the Chair, Mr. Melville "named"—Mr. Melville withdrew words and apologized, 184.		
Members declared guilty of persistent disorder, and removed from the Chamber by the Sergeant-at-Arms, 220 (?), 221 (?).		
In Committee—Deputy Chairman reported that the Honorable Member for Newcastle had crossed the Chamber and committed an assault on the Honorable Member for Mudgee, Mr. Haynes. Mr. Fletcher removed from Chamber by Sergeant-at-Arms by direction of Mr. Speaker, and motion passed suspending him for the remainder of the sitting, 345.		
In Committee—Deputy Chairman reported that Mr. McElhone had used certain words which he as Deputy Chairman had declared to be disorderly, and required Mr. McElhone to withdraw them. This the Honorable Member had declined to do, remarking, "Now you can do what you like," 479; Mr. McElhone ordered to attend in his place—Sergeant-at-Arms reported that he had failed to find Mr. McElhone—Mr. McElhone committed to the custody of Sergeant, and Speaker's warrant issued, 480; reported as put in execution, 483; motions made in reference to discharge of the Honorable Member from custody—Mr. McElhone admitted to the Bar to make explanation and apology and discharge authorized—Speaker directed Sergeant accordingly, 485, 486.		
<b>DISSENT FROM MR. SPEAKER'S RULING :—</b>		
Motion made for, and withdrawn, 49.		
Motion made for, and negatived, 4, 24, 25, 156-7, 565.		
<b>DISTRESS FOR RENT ABOLITION BILL :—</b>		
Motion made ( <i>Mr. Walker</i> ) for leave to bring in, 70; presented and read 1 <sup>o</sup> , 88; motion made for 2 <sup>o</sup> , and negatived, Order of the Day discharged, and Bill withdrawn, 107.		
<b>DISTRIBUTION OF FUNDS IN SEMPILL'S ESTATES BILL :—</b>		
Motion made ( <i>Mr. William Clarke</i> ) for leave to bring in, presented and read 1 <sup>o</sup> , 338; Order of the Day discharged, 349.		
<b>DISTRIBUTION OF FUNDS IN SEMPILL'S ESTATES BILL (No. 2) :—</b>		
Motion made ( <i>Mr. William Clarke</i> ) that Order of Leave be read, entry in Votes and Proceedings read by Clerk, presented and read 1 <sup>o</sup> , 349; read 2 <sup>o</sup> , committed, reported, report adopted, 366; read 3 <sup>o</sup> , passed, and sent to Council, 373; returned with amendments, 393; amendments agreed to, 429; assent reported, 461.		
<b>DISTRICT COURT BAILIFFS :—</b>		
Motion made ( <i>Mr. Gould</i> ) for a return showing the names of, and fees received by each during 1886 and to 30 June, 1887, distinguishing the several services for which the fees were paid, 48; Return to Order laid on Table, 492	2	635
<b>DISTRICT COURTS ACT OF 1858 :—</b>		
Annual Returns under 103 section, laid on Table, 524	2	735
<b>DISTRICT GOVERNMENT BILL :—</b>		
Motion made ( <i>Sir Henry Parkes</i> ) for Committee of the Whole, 16; House in Committee, 28; Resolution agreed to, 29; Message from Governor, 34; presented and read 1 <sup>o</sup> , 65; Order of the Day, postponed, 104, 602.	2	569
<b>DIVISIONS :—</b>		
Attendances of Members in, and Counts-out	1	653
<b>IN THE HOUSE :—</b>		
Interrupted by disorder and bars opened, 156.		
No Tellers for, 59, 140.		
Dissent from Mr. Speaker's Ruling, 25, 157, 565.		
"That the Question be now put," 24 (?), 156, 220, 221, 222, 468, 485.		
Adjournment of Debate, 4, 36, 146, 186.		
Business Days ( <i>Sessional Order</i> ), 9, 10.		
Hour of Meeting of the House, 224.		
Additional Standing Order (Right of Reply), 23.		
Local Option, 24.		
Franking Members Correspondence on Public Business, 24, 25 (?).		
Bankruptcy Bill, 36, 98.		
Borough of Balmain Wharves Bill, 41;		
Salaries of Civil Servants, 58.		
Sale of Intoxicating Drink in the Parliamentary Buildings, 59.		
Privilege—Transaction of Business while the Premier is not a Member, 76.		
Daily "Hansard," 89.		
Entry in Votes and Proceedings expunged by Order, 90 (?).		
Perpetual Trustee Company, 98.		
Newcastle Sand-drift Reclamation Act Repeal Bill, 113.		
Centenary of the Colony, 114.		

REFERENCES TO THE VOTES AND PROCEEDINGS, VOL. I—13TH PARLIAMENT—SESSION, 1887—8.	PAPERS.	
D	VOL.	PAGE.
<b>DIVISIONS—(continued) :—</b>		
<b>IN THE HOUSE—(continued) :—</b>		
Additional Standing Order, No. 5, 129.		
Free Railway Passes to Ex-members of the Legislative Assembly, 129.		
Foreign Markets for Wool and Meat—Appointment of a Commission, 130.		
Hay and Deniliquin Tramway Bill, 145.		
Pharmaceutical Society of New South Wales Incorporation Bill, 146, 233.		
Purchase by the Government of Land adjoining the Australasian Steam Navigation Company's Wharf, Vote of Censure, 329.		
Forfeited Conditional Purchases within leasehold areas ( <i>Edols v. Tearle</i> ), 353.		
Electoral Act Amendment Bill, 146.		
North Shore, Manly, and Pittwater Tramway and Railway Bill, 146.		
Colony of Australia Bill, 175 (2), 176.		
Australasian Naval Force Bill, 186 (2), 187.		
Import Duties on Agricultural Products, 233.		
Mr. Addison, Stipendiary Magistrate, 234.		
Agricultural Societies, 238.		
Conservation of Water in Lake Cudgellico and the Lower Lachlan River, 560.		
Government Railway Act Amendment Bill, 566.		
Chinese Restriction and Regulation Bill, 573.		
Property Tax Bill, 574 (2).		
The Speaker—Motion in reference to, 579.		
Crown Lands Act Further Amendment Bill, 595.		
Criminal Law Amendment Bill, 595.		
Electoral Act Amendment Bill, 603.		
The Mining Industry (Abolition of Timber Licenses), 608.		
Extension of Telegraph Lines, 609.		
Diseased Animals and Meat Bill, 609.		
Divorce Extension Bill, 451, 638.		
Adjournment of the House, 264.		
Totalizator Legalizing Bill, 273.		
Postage on Newspapers, 303, 304.		
Centenary Celebration Act Amendment Bill No. 2, 288.		
Attorney's Bills of Costs and Practice of Conveyancing Amendment Bill, 320.		
Crown Lands Bill (No. 2), 361.		
Privilege—Speech made by Mr. Haynes, 365.		
Government Railways Bill, 391.		
Postponement of Government Orders of the Day, 410.		
Sydney Hydraulic Power Company's Bill, 421.		
Thomas Thompson's Conditional Purchase made at Moama, 433.		
The Chinese, Vote of Censure, 468, 469 (2).		
Committal of Member to custody of Sergeant-at-Arms, 480.		
Privilege—Discharge of Member from custody of Sergeant-at-Arms, 485 (2), 486.		
Land Tax Bill, 501 (2), 586, 593.		
Import Duties on Agricultural Produce and Manufactures, 493, 509.		
Parliamentary Representatives Allowance Bill, 520, 548.		
Address of Condolence to Her Imperial Majesty the Empress Victoria, 530, 531.		
Privilege—Seat of Joseph Mitchell, Esq., 548.		
<b>IN COMMITTEE OF THE WHOLE :—</b>		
Borough of Balmain Wharves Bill, 657, 658.		
Municipal Roads and Streets Bill, 658.		
Payment of Members of the Legislative Assembly ( <i>Resolution</i> ), 659.		
Bankruptcy Bill, 661, 663, 665, 666, 667 (2), 668 (2), 669, 670, 671 (2), 672 (2), 673, 674, 688.		
Centenary of the Colony ( <i>Resolution</i> ), 675, 676 (2).		
Government Railways Bill, 676, 677, 678 (2), 679, 680, 681 (2), 682 (2), 683 (2), 684, 685, 686, 687 (2), 710 (2), 711 (2).		
Inland Waters Fisheries Bill, 689, 690 (2).		
Australasian Naval Force Bill, 691 (2).		
Public Works Bill, 693, 695, 696 (2), 697 (2).		
Eight Hours Bill, 699.		
Crown Lands Bill (No. 2), 701, 703, 705, 714, 715.		
Vine Diseases Act Amendment Bill, 707.		
Sydney Hydraulic Power Company's Bill, 709.		
Chinese Restriction and Regulation Bill, 717, 718, 727.		
Municipalities Act of 1867 Amendment Bill (No. 2), 719.		
Bills of Sale Act Amending Bill, 723.		
Land Tax Bill, 724 (2), 725, 728, 729 (2), 730 (2).		
Crown Lands Purchases Validation Bill, 731.		
Property Tax Bill, 741.		
<b>IN COMMITTEE OF SUPPLY :—</b>		
General Estimates for 1888 :		
Executive Council, 713.		
That Chairman leave Chair to Report <i>Point of Order</i> , 713.		
Board of Health, 720 (2).		
Loan Estimate :		
Fortifications, Warlike material, &c., 743.		
Do Warlike stores, &c., 744.		
<b>IN COMMITTEE OF WAYS AND MEANS :</b>		
Land Tax ( <i>Resolution</i> ), 711, 712.		
<b>DIVORCE EXTENSION BILL :—</b>		
Motion made ( <i>Mr. Neild</i> ) for leave to bring in, presented and read 1 <sup>o</sup> , 344; Order of the Day postponed, 361; read 2 <sup>o</sup> , committed, 451; reported with amendments, recommitted, reported 2 <sup>o</sup> with a further amendment, further recommittal negatived and report adopted, 507; read 3 <sup>o</sup> , passed, sent to Council, 513; returned with amendments, 638; motion made to consider amendments forthwith and negatived, 638; motion made to consider Council's amendments in Committee and withdrawn, 641.		
Motion made ( <i>Mr. Neild</i> ) for adjournment of the House in order to comment upon the action of the Home Government in reference to Bill of last Session, 342.		
Despatch respecting, laid on Table, 344		
Motion made ( <i>Mr. Neild</i> ) in reference to action of the Home Government in reference to Bill of last Session, and Debate adjourned, 525; Order of the Day postponed, 573, 608.	8	1061

REFERENCES TO THE VOTES AND PROCEEDINGS, VOL. I—13TH PARLIAMENT—SESSION, 1887-8.	PAPERS.	
	VOL.	PAGE.
<b>D</b>		
DIVORCE EXTENSION BILL—(continued)—		
Petition presented ( <i>Mr. Gould</i> ) from William Macquarie Cowper, M.A., Commissary of the Bishop of Sydney, against the passing of the Bill, 499 .....	8	1057
Petition presented ( <i>Mr. Street</i> ) by Ministers of Religion against the Bill, 506 .....	8	1059
DOCKER, JUDGE :—		
Motion made ( <i>Mr. J. P. Abbott</i> ) for an Address to the Governor for papers, &c., relating to claim for travelling expenses by, 287 ; Return to Address laid on Table, 451 .....	2	617
DOYLE, BRISBANE (See "OAKLEY PARK COAL-MINING COMPANY'S RAILWAY BILL").		
DOYLE, SARAH (See "OAKLEY PARK COAL-MINING COMPANY'S RAILWAY BILL").		
DRAINAGE (See "SEWERAGE;" also "PARLIAMENTARY STANDING COMMITTEE ON PUBLIC WORKS.")		
DREDGE (See "PARLIAMENTARY STANDING COMMITTEE ON PUBLIC WORKS.")		
DRILLS (See "MINING;" also "STOCK").		
DRINK COMMISSION (See "COMMISSION").		
DRUMMOYNE PARK WHARF :—		
Motion made ( <i>Mr. Carruthers</i> ) for all leases, tenders, and correspondence relating to leasing of, 122 ; Return to Order, laid on Table, 199 .....	3	1021
DUBBO (See "RAILWAYS").		
DUCKENFIELD COLLIERY (See "MINING").		
DUTY (See "FINANCE").		
<b>E</b>		
EASTGROVE :—		
RAILWAY CROSSING TO CONNECT GOULBURN :—		
Motion made ( <i>Mr. Teece</i> ) for papers, 386 ; Return to Order laid on Table, 454 .....	6	971
EDDY, MR. E. M. G. :—		
Correspondence respecting the appointment of, as Chairman of the Railway Board, laid on Table, 537 .....	6	625
EDUCATION (See also "STATISTICS") :—		
CHARLOTTE BRENNING :—		
Petition from, that she has served as teacher under the Department of Public Instruction for three years, that through being sent to places where great hardships had to be endured, her health was greatly effected, and having applied for removal, her resignation was accepted, and praying the appointment of a Select Committee, presented, 135 .....	4	515
PUBLIC INSTRUCTION ACT :—		
Regulations under, laid on Table, 6 (?) .....	4	517, 519
Prosecution under Compulsory Clause, Information respecting, laid on Table, 437 .....	4	501
RESUMPTIONS OF LAND FOR PUBLIC SCHOOL PURPOSES :—		
Notifications of, laid on Table, 70, 155, 246, 257, 341, 360, 408, 496, 553, 608 .....	4	525 to 545
RESUMPTION OF LAND FOR SCHOOL PURPOSES, PARISH OF HOLDSWORTHY :—		
Motion made ( <i>Mr. Gibbes</i> ) for all papers in connection with the, 130 ; Return to Order laid on Table, 454 .....	4	511
UNIVERSITY OF SYDNEY :—		
Amended By-laws, laid on Table, 6, 257(?) .....	4	557, 569, 571
Information respecting examination fees, laid on Table, 348 .....	4	555
Report for 1887, laid on Table, 524 .....	4	547
MR. J. A. SMITH, PUBLIC SCHOOL TEACHER AT COOLA CREEK :—		
Return to Order ( <i>Second Session</i> , 1887), laid on Table (not printed), 6.		
TECHNICAL :—		
Report by Edward Combes, C.M.G., on, laid on Table, 28 .....	4	229
FREE RAILWAY PASSES TO SCHOOL CHILDREN :—		
Motion made ( <i>Mr. J. P. Abbott</i> ) for all minutes and other documents, written or sent by any Minister or Officer of the Civil Service, in reference to the Resolution authorizing, passed last Session, 40 ; Return to Order, laid on Table, 231 .....	6	711
CASE OF THOMAS DEAN :—		
Correspondence relating to, summoned at Balmain under the Public Instruction Act, laid on Table (not printed), 62.		
SCHOOL ATTENDANCE OFFICERS :—		
Copies of minutes, instructions, and circulars respecting, laid on Table, 75 .....	5	493
SYDNEY GRAMMAR SCHOOL :—		
Report for 1886, laid on Table, 285 .....	4	573
Report for 1887, laid on Table, 432 .....	4	581
CLASSIFICATION OF TEACHERS :—		
Motion made ( <i>Mr. Frank Farnell</i> ) for return of information respecting 1B and 1A certificates, 361 ; Return to Order laid on Table, 389 .....	4	489
AGRICULTURAL COLLEGE :—		
Motion made ( <i>Mr. Kethel</i> ) for Address to Governor for establishment of, and, by leave, withdrawn, 370.		
STATE CHILDREN'S RELIEF DEPARTMENT :—		
Report on, for year ended 5th April, 1888, 565. ....	4	753
PUBLIC INSTRUCTION :—		
Report of the Minister on, for the year 1887, laid on the Table, 408 ; Annex XVII to, 425 .....	4	1
Information respecting persons employed in Department who have attained the age of sixty years, laid on Table, 635 .....	4	487
FOREST VALE SCHOOL :—		
Motion made ( <i>Mr. Lyne</i> ) for minutes and correspondence in reference to, 429 ; Return to Order laid on Table, 560 .....	4	503
RESUMPTION OF PROPERTIES FOR SCHOOL PURPOSES, ELIZABETH AND CASTLEREAGH STREETS.		
Motion made ( <i>Mr. Withers</i> ) for Return showing date, amount of purchase money, &c, 463.		
EIGHT HOURS BILL :—		
Motion made ( <i>Mr. Schey</i> ) for Committee of the Whole, 36 ; House in Committee, Resolution agreed to, presented and read 1 <sup>o</sup> , 42 ; Order of the Day postponed, 77, 145, 252 ; read 2 <sup>o</sup> , committed ; no Report from Committee, 342.		
ELECTIONS AND QUALIFICATIONS COMMITTEE (See "ELECTORAL").		

REFERENCES TO THE VOTES AND PROCEEDINGS, VOL. I—13TH PARLIAMENT—SESSION, 1887-8.	PAPERS.	
	VOL.	PAGE.
<b>E</b>		
<b>ELECTORAL</b> (See also "MINISTERIAL ELECTION BILL"; also "WENTWORTH ELECTORATE SUBDIVISION BILL") :—		
<b>PADDINGTON</b> :—		
Resignation of W. J. Trickett, Esq., and issue of Writ reported—Return of Writ, certifying to the Return of William Johnston Allen, Esq., reported, 249; Mr. Allen sworn, 253.		
<b>NEWTOWN</b> :—		
Death of Frederick Jamison Gibbes, Esq., issue and return of Writ, reported, Mr. Joseph Abbott sworn, 249.		
Resignation of William John Foster, Esq., reported and seat declared vacant, 269; issue and return of Writ, reported, Mr. Joseph Mitchell sworn, 303.		
<b>WENTWORTH</b> :—		
Resignation of W. P. Macgregor, Esq., and issue of writ reported, 1; return of writ certifying to election of T. F. De Courcy Browne, certain irregularities in holding the election, and proclamation curing the same, reported, 73; Mr. Browne sworn, 76.		
<b>ROLLS</b> :—		
For 1887-8, laid on Table, 257		
For 1880 to 1888, showing operation of expansive clauses of Electoral Act of 1884, laid on Table, 369 .....	1	921
<b>ELECTIONS AND QUALIFICATIONS COMMITTEE</b> :—		
Speaker's Warrant laid on Table, 17, 269; maturity reported, 37, 287; Members sworn, 37 (?), 287; first meeting appointed, 53; leave given to adjourn <i>sine die</i> , 55, 296.		
<i>Seat of the Honorable Bernhard Ringrose Wise, Esquire.</i>		
Motion made ( <i>Mr. Dibbs</i> ) to refer, whether he has since his election accepted an office of emolument in having accepted a fee of fifty-five guineas from the Commissioner for Railways, in contravention of the 28th section of the Constitution Act, 53; Report brought up, 55.....	1	903
<i>Seat of John Haynes, Esquire.</i>		
Motion made ( <i>Mr. Melville</i> ) to refer, whether it has not and is not now vacant by reason of his becoming a bankrupt or an insolvent debtor, and negatived, 145.		
<i>Seat of Joseph Mitchell, Esquire.</i>		
Motion made ( <i>Mr. Copeland</i> ) to refer seat to, in consequence of alleged corrupt practices at the last election, and negatived, 548.		
<i>Election Petition—Paddington—Hellmrich v. W. J. Allen.</i>		
Mr. Speaker laid on Table Election Petition from Charles Hellmrich, alleging that at some polling booths votes were declared informal which were not informal and should have been counted for Petitioner, that the ballot papers were wrongly counted at some of the polling booths, that Mr. W. J. Allen was declared duly elected, and praying that Mr. Allen's election be declared null and void, that a scrutiny of the ballot papers be made by the Committee of Elections and Qualifications, and that your Petitioner may be declared duly elected—Petition referred to Committee, 269; Report brought up, 296 .....	1	891
<b>ACT</b> :—		
Motion made ( <i>Mr. Schey</i> ) for amendment so as to give the franchise to members of the Police Force, Permanent Artillery, and to all other adult males who shall not be otherwise under disability, and withdrawn, 25.		
<b>NAMOI DISTRICT</b> :—		
Motion made ( <i>Mr. Dangar</i> ) for a return showing entire revenue from, under Crown Lands, Mining Leases and Licenses, Miners' Rights and Timber Licenses, 41.		
<b>ST. LEONARDS</b> :—		
Resignation of Sir Henry Parkes as a Member for, reported—seat declared vacant, 73; issue and return of writ reported—Sir Henry Parkes sworn, 87.		
<b>CENTRAL CUMBERLAND</b> :—		
Resignation of A. H. McCulloch, jun., Esq., reported,—seat declared vacant, 222, 419; issue and return of Writ reported, 249, 463; Mr. A. H. McCulloch, jun., sworn, 253; David Buchanan sworn, 463.		
Resignation of Varney Parkes, Esq., reported,—seat declared vacant, 311; issue and return of Writ reported, 339; Mr. John Nobbs sworn, 342.		
<b>ELECTORAL ACT AMENDMENT BILL</b> :—		
Motion made ( <i>Mr. Haynes</i> ) for leave to bring in, 17; presented and read 1 <sup>o</sup> , 35; Order of the Day postponed, 77; motion made for 2 <sup>o</sup> and negatived, Order of the Day discharged and Bill withdrawn, 146.		
Motion made ( <i>Sir Henry Parkes</i> ) for leave to bring in, presented and read 1 <sup>o</sup> , 592; read 2 <sup>o</sup> , committed, 603.		
<b>ELECTORATES OF THE GWYDIR AND INVERELL BOUNDARIES AMENDMENT BILL</b> :—		
Motion made ( <i>Mr. Moore</i> ) for leave to bring in, presented and read 1 <sup>o</sup> , 484.		
Petitions from residents of Little Plain, near Inverell, in favour of the passing of the Bill, 585.		
<b>ELECTRIC CARS</b> (See "TRAMWAYS").		
<b>ELECTRIC LIGHT</b> (See also "PARLIAMENT") :—		
<b>THE "GULCHER" MACHINE</b> :—		
Motion made ( <i>Mr. Thompson</i> ) for all letters, correspondence, &c., relating to, purchased by Telegraph Department, 147; Returns to Order, laid on Table, 231, 273 .....	4	1191, 1197
<b>APPARATUS PURCHASED BY GOVERNMENT</b> :—		
Motion made ( <i>Mr. Wall</i> ) for return of, giving dates of purchase, time of delivery, and authority of purchase, and whether in use, 267.		
<b>MACQUARIE LIGHTHOUSE</b> :—		
Motion made ( <i>Mr. Wall</i> ) for correspondence between Colonial Architect and the Superintendent of Telegraphs, 267; Return to Order, laid on Table, 543 .....	4	1199
<b>ELECTRIC LIGHTING BILL</b> (See "SYDNEY AND SUBURBAN ELECTRIC LIGHTING BILL").		
<b>ELIZABETH AND CASTLEREAGH STREETS PROPERTY</b> (See "EDUCATION").		
<b>ELLIS DR.</b> (See "RABBIT PEST").		
<b>EMERY, MR. G. H.</b> (See "CIVIL SERVICE").		
<b>EMERY V. BARCLAY</b> (See "ADMINISTRATION OF JUSTICE").		
<b>EMPLOYERS LIABILITY ACT AMENDMENT BILL</b> :—		
Motion made ( <i>Mr. Garrard</i> ) for leave to bring in, 40.		
<b>EMPLOYEES</b> (See "RAILWAYS"; also "TRAMWAYS").		
<b>EMPRESS VICTORIA OF GERMANY</b> (See "ADDRESS").		
<b>ENDOWMENT TO MUNICIPALITIES</b> :—		
Opinions of Attorneys-General in years 1876 and 1888 on, laid on Table, 642.....	2	273
<b>ENGINES</b> (See "RAILWAYS").		
<b>ENGINE-SHEDS.</b> (See "RAILWAYS").		

REFERENCES TO THE VOTES AND PROCEEDINGS, VOL. I—13TH PARLIAMENT—SESSION, 1887-8.	PAPERS.	
	VOL.	PAGE.
<b>E</b>		
<b>ESSEX-STREET ALIGNMENT BILL:—</b>		
Motion made ( <i>Mr. Garrett</i> ) for leave to bring in, presented and read 1 <sup>o</sup> , 437; read 2 <sup>o</sup> , committed, reported without amendment, report adopted, 561; read 3 <sup>o</sup> , passed and sent to Council, 567.		
<b>ESTIMATES</b> (See "FINANCE").		
<b>EVANS COMBINATION TRUCK</b> (See "RAILWAYS").		
<b>EXAMINATION FEES</b> See ("UNIVERSITY OF SYDNEY").		
<b>EXAMINER OF ACCOUNTS</b> (See "ASSISTANT-EXAMINER OF ACCOUNTS").		
<b>EXAMINER OF COAL-FIELDS:—</b>		
Report of, on charges made against him in the Legislative Assembly, laid on Table, 273 .....	8	217
<b>EXAMINERS OF TITLES</b> (See "CIVIL SERVICE").		
<b>EXCLUSION OF STRANGERS:—</b>		
Sessional Order passed, 12.		
<b>EXHIBITION</b> (See "ADELAIDE JUBILEE INTERNATIONAL EXHIBITION"; also, "CENTENNIAL INTERNATIONAL EXHIBITION, MELBOURNE").		
<b>EXPENDITURE:—</b>		
Statement of, on National and Local Works in the Colony, from 1860 to 1886, laid on Table, 28...	8	1231
Statement of Annual, of Colony during 1881 to 1886, and the actual and estimated during 1887; also population and rate per head, laid on Table, 219 .....	3	495
Statement of Annual, of Colony on account of Loan Services during 1881 to 1886, and the actual and estimated, during 1887, the population and rate per head, laid on Table, 219 .....	3	503
<b>EXPLANATORY TESTRACTS:—</b>		
Of Sums Estimated and Voted.....	3	851
<b>EXPORTS</b> (See "STATISTICS").		
<b>EXPLOSIVE GAS</b> (See "MINING")		
<b>EXPLOSIVES:—</b>		
Amended Rates and Charges for Lightering, Delivering, and Storing laid on Table, 280.....	8	1207
<b>EXPUNGED ENTRY:—</b>		
By Order of Assembly, 90.		
Speaker states course intended to be pursued to record,—motion made to instruct Speaker as to entry in Votes and Proceedings, 91.		
<b>EXTRADITION PAPERS:—</b>		
Despatch respecting authentication of, laid on Table, 352 .....	8	1067
<b>F</b>		
<b>FACTORIES AND WORKSHOPS REGULATION BILL:—</b>		
Received from Legislative Council, read 1 <sup>o</sup> ; printed, 614; Order of the Day postponed, 619.		
<b>FARES AND FREIGHTS</b> (See "RAILWAYS").		
<b>FARM PRODUCE</b> (See "AGRICULTURAL PRODUCTS").		
<b>FARNELL, MR. J. S., M.P.:—</b>		
Leave of Absence granted to, 437.		
<b>FEES</b> (See "CIVIL SERVICE"; also "UNIVERSITY OF SYDNEY").		
<b>FENCING</b> (See also "CROWN LANDS"; also, "CROWN LANDS ACT FURTHER AMENDMENT BILL"):—		
Notification of further amendment of Section 5 of Schedule of Classes, under the Crown Lands Act, laid on Table, 40, 199, 613 .....	5	585, 587, 589
<b>FENNELL, STEPHEN</b> (See "CROWN LANDS PURCHASES VALIDATION BILL").		
<b>FERGUSON, DAVID A., ESQ., M.P.:—</b>		
Leave of Absence granted to, for four weeks, 17, 112.		
<b>FERGUSON, MR. GEORGE ROBERT EDWARD</b> (See "CROWN LANDS").		
<b>FERRIES:—</b>		
<b>GOVERNMENT:—</b>		
Motion made ( <i>Mr. Bowes</i> ) for abolition of Tolls and Dues on, 608.		
<b>FEVER, OUTBREAK OF, AT GLENDUART, MORUYA:—</b>		
Motion made ( <i>Mr. Lakeman</i> ) for all papers relating to, 519; Return to Order, laid on Table, 578.	2	239
<b>FIELD OF MARS COMMONS:—</b>		
Returns to Order ( <i>Second Session of 1887</i> ), laid on Table, 103, 432 .....	5	827
<b>FINANCE</b> (See also, "PROPERTY TAX BILL," and "LAND TAX BILL"; also "FINANCE"):—		
<b>REVENUE, RECEIPTS, AND EXPENDITURE:—</b>		
Abstracts for Quarter ended 30th June, 1888, laid on Table, 561.		
<b>RECEIPTS AND EXPENDITURE:—</b>		
Statement of, together with the Auditor General's Report thereon for 1886, laid on Table, 2 .....	3	509
Do do do for 1887, laid on Table, 563 ...	3	657
<b>BANK LIABILITIES AND ASSETS:—</b>		
For the Quarter ended 30th June 1887, laid on Table 5 .....	3	843
Do 30th September, 1887, laid on table, 135.....	3	845
Do 31st March, 1888, laid on Table, 475 .....	3	847
<b>BANKING, LAND, BUILDING, AND INVESTMENT COMPANIES:—</b>		
General Summary for Quarter ended 31st March, laid on Table, 475.....	3	849
<b>SUPPLY:—</b>		
Committee of, Sessional Order passed, 11.		
Motion made ( <i>Mr. Burns</i> ) for House to go into Committee, 174, 295, 345, 409, 433, 452, 476, 480, 544, 548, 553, 554, 610, 613, 619.		
House in Committee, 201, 242, 295, 345, 409, 433, 452, 476, 480, 544, 548, 553, 554, 610, 613, 619.		
Resolutions reported, 201, 242, 295, 345, 409, 480, 553, 619.		
Resolutions agreed to, 201, 242, 295, 345, 409, 480, 553, 625.		
<b>WAYS AND MEANS:—</b>		
Committee of, Sessional Order passed, 11.		
Motion made ( <i>Mr. Burns</i> ) for House to go into Committee, 174, 205, 346, 409, 430, 481, 501, 554, 561, 627.		
House in Committee, 201 ( <i>Financial Statement</i> ), 229, 234, 241, 242, 247, 295, 346, 409, 430, 481, 501, 554, 561, 627.		
Resolutions reported, 242, 248, 295, 346, 409, 430, 481, 554, 561, 627.		
Resolutions agreed to, 242, 248, 295, 346, 409, 430, 481, 554, 561, 627,		
Estimates for 1888 ( <i>Mr. Burns</i> ) laid on Table, 201, 613,		



REFERENCES TO THE VOTES AND PROCEEDINGS, VOL. I—13TH PARLIAMENT—SESSION, 1887-8.		PAPERS.	
		VOL.	PAGE.
<b>F</b>			
<b>FINANCE—(continued):—</b>			
<b>EXPENDITURE ON NATIONAL AND LOCAL WORKS:—</b>			
Statement of, in the Colony, from 1860 to 1886, laid on Table, 28. ....	8	1231	
<b>IMPORT DUTIES ON AGRICULTURAL PRODUCTS:—</b>			
Motion made ( <i>Mr. Copeland</i> ) that it is desirable to encourage the agricultural interest by imposing import duties on grain, beans, peas, barley, oats, hay, chaff, flour, meal, bran, pollard, sharps, and potatoes, and Debate adjourned, 169; negatived, 233.			
Petition presented ( <i>Mr. Copeland</i> ) representing that the farming industry is in a deplorable condition, and praying the House to grant relief, read by the Clerk, 492 .....	3	873	
Petition presented ( <i>Mr. Copeland</i> ) from farmers of Inverell, in favour of specific duty on grain, 492.	3	871	
Motion made ( <i>Mr. Copeland</i> ) for moderate import duties on, and on all articles which can be locally manufactured, and the Question not having been put at 7 o'clock, Government business took precedence, 493; Order of the Day postponed, 506; Debate resumed and Question negatived, 509.			
Petition presented ( <i>Mr. Crouch</i> ) in favour of, and praying the House to pass <i>Mr. Copeland's</i> Resolutions, 496.....	3	869	
Petition presented ( <i>Mr. Copeland</i> ) from farmers, agriculturalists, and labourers of Central New England, praying for the imposition of import duties on agricultural productions that can be grown in the Colony, and read by the Clerk, 505 .....	3	877	
Petition presented ( <i>Mr. Ewing</i> ) from Public Meeting, held at Tatham, in favour of, 519.....	3	875	
<b>ESTIMATES:—</b>			
Message No. 14 ( <i>Mr. Burns</i> ) recommending accompanying for 1888, and Supplementary for 1887, and previous years, laid on Table, 200.....	3	1	
Ways and Means for 1888 ( <i>Mr. Burns</i> ) laid on Table, 201, 613 .....	3	371, 461	
Schedule to, for 1888, showing total remuneration of all Public Officers, laid on Table, 228 .....	3	153	
Mr. Speaker ruled as properly before the House, notwithstanding that the Salaries shown were lower than those provided for by the Civil Service Act, 433.			
Mr. Speaker ruled that Schedules A, B, C, were not open for discussion, as they were already provided for by Act of Parliament, 433.			
Mr. Speaker declined to overrule the decision of Deputy Chairman in reference to words used by <i>Mr. McElhone</i> in Committee of Supply, 452.			
Message No. 56 ( <i>Mr. Burns</i> ) asking for Return of that portion of the Estimates-in-Chief having reference to the Colonial Secretary's Department, 491 .....	3	259	
Message No. 66, recommending accompanying Amended Estimates for Departments under control of Colonial Secretary, 545 .....	3	295	
Message No. 73 ( <i>Mr. Burns</i> ) recommending accompanying Further Supplementary for 1887 and Additional for 1888, laid on Table, 610 .....	3	331	
Message No. 74 ( <i>Mr. Burns</i> ) recommending accompanying Further Additional for 1888, laid on Table, 610 .....	3	353	
Message No. 75 ( <i>Mr. Burns</i> ) recommending accompanying Additional Estimate on Account of Repayment of Loans, laid on Table, 610.....	3	359	
Message No. 76 ( <i>Mr. Burns</i> ) recommending accompanying Loan Estimates for 1888, laid on Table, 610.....	3	365	
<b>EXPLANATORY ABSTRACTS:—</b>			
Of sums estimated and voted .....	3	551	
<b>FINANCIAL STATEMENT:—</b>			
Made by <i>Mr. Burns</i> , 201, 361, 610.			
<b>ACCOUNTS:—</b>			
Deficit for 1886 and previous years, laid on Table, 208 .....	3	501	
Annual Expenditure of Colony, during 1881-6, and the actual and estimated Expenditure during 1887, showing population and rate per head, laid on Table, 219 .....	3	495	
Annual Expenditure of Colony, during 1881-6, on Loan Services, and the actual and estimated Expenditure during 1887, showing population and rate per head, laid on Table, 219 .....	3	503	
Statement of Consolidated Revenue Fund for 1888, laid on Table, 219 .....	3	497	
Return showing the Amounts due by the Consolidated Revenue Fund to the Loan Funds and Trust Funds on 30 April, 1888, laid on Table, 538 .....	3	499	
Adjournment of the House moved to consider statement of Treasurer in reference to the Public Accounts, 561.			
<b>FINANCIAL POLICY OF THE GOVERNMENT—VOTE OF CENSURE:—</b>			
Motion made ( <i>Mr. Dibbs</i> ) that Financial Policy of the Government is unsatisfactory, amendment moved confining the question to such of the financial proposals of the Government as refer to the reduction of the Civil Service Salaries, and debate adjourned, 208; debate resumed and further adjourned, 210, 216; debate resumed, disorder arose, and fourteen members removed from the Chamber, 220, 221; amendment and original motion negatived, 222.			
<b>IMPORT DUTY ON TIMBER:—</b>			
Petition from Proprietors of Saw Mills that if the reduction of the duty be carried, the Colonial trade will be crippled, and praying that the reduction be not sanctioned, 240. ....	3	879	
<b>INSCRIBED STOCK ACT OF 1883:—</b>			
Fifth Report on the Creation Inscription and issue of Stock under, laid on Table, 257.....	3	505	
<b>PROPOSED NEW TARIFF:—</b>			
Petition from residents of Broughton Creek, Brogher's Creek, Broughton Vale, and Kangaroo Valley, against the abolition of the Customs Duties on Farm Produce, presented and read by the Clerk, 252. ....	3	881	
<b>LOAN OF INSCRIBED STOCK:—</b>			
Correspondence by Cable in reference to floating of, laid on Table, 420 .....	3	815	
<b>ROAD TRUSTS ACCOUNTS:—</b>			
Half-year ending 30th June and 31st December, 1887, laid on Table, 505 .....	5	937	
<b>ASSISTANT EXAMINER OF ACCOUNTS, TREASURY:—</b>			
Return respecting applications for position of, laid on Table, 524 .....	2	111	
<b>FINANCIAL BUSINESS:—</b>			
Ministerial Statement made by <i>Sir Henry Parkes</i> , 405, 501.			
<b>FIRE BRIGADES ACT.</b>			
<b>GOULBURN BOARD:—</b>			
Report for 1887, laid on Table, 302.....	2	609	
<b>TAMWORTH BOARD:—</b>			
Regulation of, laid on Table, 6, 578.....	2	611, 613	
<b>METROPOLITAN BOARD:—</b>			
Report for 1887, laid on Table, 378.....	2	571	
<b>DENILIQVIN BOARD:—</b>			
Report for 1887-8, laid on Table, 462.....	2	605	
Regulations, laid on Table, 634.....	2	607	

REFERENCES TO THE VOTES AND PROCEEDINGS, VOL. I—13TH PARLIAMENT—SESSION, 1887-8.	PAPERS.	
	VOL.	PAGE.
<b>F</b>		
FISHERIES (See also "INLAND WATERS FISHERIES BILL") :— Report on, by the Commissioners, up to 31st December, 1886, laid on Table, 223 .....	8	1069
Mr. OLIVER, LATE INSPECTOR :— Motion made ( <i>Mr. Dawson</i> ) for papers connected with removal of, 303; Return to Order, laid on Table, 412 .....	2	123
FITZROY WATERFALLS :— Plan of forty-five portions of Crown Lands situated near the village of Yarrunga at, measured for sale, laid on Table, 228 .....	5	201
FLETCHER, JAMES, ESQ., M.P. :— A MEMBER FOR NEWCASTLE :— Removed from Chamber by Sergeant-at-Arms, by direction of Mr. Speaker, and suspended for the remainder of the Sitting, for assaulting Mr. Haynes, a Member for Mudgee, 345.		
FORBES (See also "RAILWAYS," "MUNICIPAL"; also PUBLIC BUILDINGS"; also CROWN LANDS") :— Motion made ( <i>Mr. Stokes</i> ) for papers in connection with Special Audit of Municipal Accounts, 325; Return to Order, laid on Table, 334 .....	2	279
FORCES (See "MILITARY").		
FOREIGN DESERTERS ACT, 1852 :— Despatches respecting, laid on Table, 135, 356 .....	8	1181, 1183
FOREIGN MARKETS FOR WOOL AND MEAT :— APPOINTMENT OF A COMMISSION :— Motion made ( <i>Mr. Waddell</i> ) for, to obtain all possible information to assist in opening up 129 and negatived, 130.		
FORESHORES OF SYDNEY HARBOUR :— DR. BOTTRELL'S CLAIM TO :— Motion made ( <i>Mr. Lyne</i> ) for all papers connected with, 40; Return to Order, laid on Table, 185.	3	885
FOREST BRANCH (See "MINING").		
FOREST VALE SCHOOL (See "EDUCATION").		
FORESTS (See "STATE FORESTS AND FOREST RESERVES.")		
FORFEITED CONDITIONAL PURCHASES (See "CROWN LANDS")		
FORMAL BUSINESS :— Sessional Order passed, 10.		
FORMATION OF STREET, NORTH OF THE GENERAL POST OFFICE :— Message from His Excellency the Governor recommending that provision be made for, 383. Motion made ( <i>Mr. Roberts</i> ) for Committee of the Whole to consider Resolutions, 390; Order of the Day postponed, 410; House in Committee, 416, 479, 484, 487. Motion made ( <i>Mr. Dibbs</i> ) for plan showing proposed new street, and also <i>Mr. Dibbs's</i> proposed alteration, 454; Return to Order, laid on Table ( <i>as an exhibit only</i> ), 602. Correspondence and Papers respecting, laid on Table, 484 .....	4	1141
FOSTER, GEORGE (See "CROWN LANDS").		
FOSTER, WILLIAM JOHN ESQ., M.P. :— Resignation of, as a Member for Newtown, reported, and seat declared vacant, 269.		
FRANKING MEMBERS CORRESPONDENCE (See "POSTAL").		
FRAUD, ALLEGED (See "STAMP DUTIES ACT"; also "RAILWAYS").		
FREDERICKTON :— PUBLIC WHARF AT, MACLEAY RIVER :— Notification of resumption under Lands for Public Purposes Acquisition Act, of land in parish of Kempsey, county of Gordon, laid on Table, 432 .....	3	1049
FREE PASSES (See "RAILWAYS").		
FREE PUBLIC LIBRARY (See "BY-LAWS"; also "SYDNEY FREE PUBLIC LIBRARY").		
FRENCH MILITARY POSTS (See "NEW HEBRIDES").		
FRIDAY (See "ADDITIONAL SITTING DAY").		
FRIEZE WORK (See "TELEPHONES.")		
FRUIT GROWING :— Petition from New South Wales Fruitgrowers Union that they have agreed upon certain principles for the protection of the industry, which they pray should be embodied in an Act, presented, 127. ....	8	1185
FUEL BILL :— Motion made ( <i>Mr. Alfred Allen</i> ) for Committee of the Whole, 40; Order of the Day postponed, 58, 107; House in Committee, Resolution agreed to, 253; presented and read 1 <sup>o</sup> , 263; Order of the Day postponed, 353, 425, 476, 598.		
FUGITIVE CRIMINALS :— Despatch in reference to surrender of, laid on Table, 285 .....	8	1281
<b>G</b>		
GAOLS (See also "ADMINISTRATION OF JUSTICE") :— PARRAMATTA :— Notification of resumption, under Lands for Public Purposes Acquisition Act, of land in parish of Field of Mars, required for extension of, laid on Table, 231 .....	4	1227
GARRARD, JACOB, ESQ., M.P. :— Appointed Chairman of Committees for the day only, 359, 363, 395. Appointed with three others to act temporarily as Chairman of Committees in the absence of the Member appointed to that office, 389. Mr. Speaker calls on, to act as Deputy Chairman for the day only, 403, 425, 432, 468, 484, 493, 500, 513, 538, 543, 573.		
GARRETT, THE HON. THOMAS, M.P. (See also "TERALBA COAL MINING RESERVE") :— Resignation of, as Minister for Lands, 613.		
PRIVILEGE— <i>Garrett v. Dibbs</i> :— Motion made ( <i>Mr. Dibbs</i> ) that the Crown Solicitor be instructed to defend the action <i>Garrett v. Dibbs</i> in the interests of the privileges of this House, and negatived, 326.		
MINERAL LANDS HELD BY :— Return respecting, laid on Table, 578. ....	8	263
GARSED MR. JOHN :— Motion made ( <i>Mr. Hurley</i> ) for letters addressed to the Attorney-General, on 8th June and 21st July, with the reply dated 14th September, 1887, 131; Return to Order, laid on Table, 185. ....	8	1227
GARVAN, MR. :— A MEMBER FOR EDEN :— Declared guilty of persistent disorder and removed by the Sergeant-at-Arms from the Chamber, 220.		

REFERENCES TO THE VOTES AND PROCEEDINGS, VOL. I—13TH PARLIAMENT—SESSION, 1887—8.	PAPERS.	
G	VOL.	PAGE.
<b>GENERAL BUSINESS :—</b>		
Sessional Order passed, as to precedence of, 10.		
Notices of Motions postponed in a bunch, 162, 208, 242, 248, 487.		
Notice of Motion postponed, 502.		
Orders of the Day postponed in a bunch, 248, 487.		
<b>GENERAL POST OFFICE (See "POSTAL").</b>		
<b>GHINNY GHINNY :—</b>		
<b>WHARF OVER MANNING RIVER :—</b>		
Notification of resumption under Lands for Public Purposes Acquisition Act of land in Parish of Cudal, County of Macquarie, laid on Table, 475 .....	3	1051
<b>GIBBES, FREDERICK JAMISON, ESQUIRE :—</b>		
Death of the Honorable Member for Newtown reported, 249.		
<b>GIPPS, MR. F. B. :—</b>		
Letter, dated 5th July, 1888, as an Appendix to Return respecting Kenny Hill and Pott's Hill Reservoir Schemes, laid on Table, 578.....	5	869
<b>GLEBE ISLAND ABATTOIRS :—</b>		
Petition, Municipal District Council of Leichhardt, for the abolition of, presented, 16 .....	8	669
<b>GLENDUART, MORUYA :—</b>		
<b>OUTBREAK OF FEVER :—</b>		
Motion made ( <i>Mr. Lakeman</i> ) for copies of all papers relating to, 519; Return to Order, laid on Table, 578 .....	2	239
<b>GLENTHORNE :—(See "ROADS").</b>		
<b>GOLD MINING (See "MINING").</b>		
<b>GOULBURN (See also "SAINT SAVIOUR'S GLEBE LAND LEASING BILL"; also "RAILWAYS") :—</b>		
Report of Fire Brigades Board for 1887, laid on Table, 302 .....	2	609
<b>GOULBURN AND TUENA TRAMWAY BILL :—</b>		
Petition presented ( <i>Mr. Stevenson</i> ) for leave to bring in, 492; leave given, presented and read 1 <sup>o</sup> , 496; referred to Select Committee, 500; Report brought up, 523; Order of the Day postponed, 585; motion made for 2 <sup>o</sup> , and debate adjourned, 599; Order of the Day postponed, 628 .....	2	907
<b>GOULD, ALBERT JOHN, ESQ., M.P. :—</b>		
Speaker's Warrant appointing, as Member of Elections and Qualifications Committee, laid on Table, 269; maturity of Warrant reported and Member sworn, 287.		
Added to Standing Orders Committee, 280.		
Appointed temporarily with three others to act as Chairman of Committees in the absence of the Member appointed to that office, 389.		
Mr. Speaker calls on to act as Deputy Chairman of Committees for the Day only, 420, 437, 454, 476, 519, 565.		
<b>GOVERNMENT (See also "TRAMWAYS") :—</b>		
Motion made ( <i>Mr. Garvan</i> ) for adjournment of the House in reference to certain actions of, and Point of Order raised, That notice did not state "a definite matter" of public importance. Mr. Speaker pointed out that, by a previous decision of the House, he had been relieved of the responsibility of deciding the point, which should have been taken before the motion was stated, 635; motion negatived, 635.		
<b>ASYLUMS (See "ASYLUMS").</b>		
<b>BUSINESS :—</b>		
Precedence of, Sessional Order passed, 10.		
Do. after 7 o'clock on Friday (additional day), 103, 123, 140, 166, 234.		
Do. after 7 o'clock on Tuesday, 408, 422, 433, 452, 476, 493, 508, 525, 543, 561, 580, 609.		
Orders postponed in a bunch, 417, 430, 463, 468, 487, 502, 509, 628.		
<b>ELECTRIC LIGHT APPARATUS PURCHASED BY :—</b>		
Motion made ( <i>Mr. Wall</i> ) for return, giving dates of purchase, time of delivery, &c., and authority of purchase, and whether in use, 267.		
<b>PRINTING OFFICE :—</b>		
Annual Return to Order, for 1887 ( <i>Session 1883-4</i> ), laid on Table, 302.....	8	1187
Motion made ( <i>Mr. Frank Smith</i> ) for return in reference to private work done at Government Printing Office, 500; Return to Order laid on Table, 515 .....	8	1197
<b>PREMISES RENTED BY :—</b>		
Further Return to Order ( <i>Second Session 1887</i> ), laid on Table, 191 .....	8	1249
<b>PURCHASE BY, OF LAND ADJOINING THE AUSTRALASIAN STEAM NAVIGATION COMPANY'S WHARF :—</b>		
Motion made ( <i>Mr. Melville</i> ) for a Select Committee to inquire into and report upon, Committee appointed by ballot, 29; Report brought up, 305 .....	3	917
Motion made ( <i>Mr. Dibbs</i> ), That the evidence of the Select Committee discloses injudicious and unsatisfactory administration by the Government, and that the amount paid was in excess of its value, 329.		
Correspondence respecting, laid on Table, and referred to Select Committee, 51 .....	3	1011
<b>PURCHASE BY, OF AUSTRALASIAN STEAM NAVIGATION COMPANY'S WHARF :—</b>		
Motion made ( <i>Mr. Trickett</i> ) for all claims, correspondence, valuations, &c, connected with, 136; Return to Order, laid on Table, 191 .....	3	1013
<b>SAVINGS BANK :—</b>		
Statement of Accounts for 1887, 356 .....	3	819
<b>GOVERNMENT RAILWAYS ACT AMENDMENT BILL :—</b>		
Message from Governor, 539; motion made ( <i>Sir Henry Parkes</i> ) for Committee of the Whole, 546; House in Committee, resolution agreed to, presented, and read 1 <sup>o</sup> , 561; read 2 <sup>o</sup> , committed, reported without amendment, report adopted, 567; read 3 <sup>o</sup> , passed, 573; sent to Council, 574; returned without amendment, 593; Assent reported, 619.	6	1105
<b>GOVERNMENT RAILWAYS BILL :—</b>		
Motion made ( <i>Sir Henry Parkes</i> ) for Committee of the Whole, 16; House in Committee, resolution agreed to, 29; Message from Governor, 35; presented and read 1 <sup>o</sup> , 52; motion made for 2 <sup>o</sup> , and debate adjourned, 104; resumed and further adjourned, 115; resumed, read 2 <sup>o</sup> , and committed, 119; further considered in Committee, 123, 136; reported with amendments, 136; recommitted, 152; further considered in Committee, and reported 2 <sup>o</sup> , with further amendments, 162; recommitted and reported 3 <sup>o</sup> , with further amendments, 201; report adopted, 225; Order of the Day postponed, 240; read 3 <sup>o</sup> , passed, and sent to Council, 258; returned with amendments, 378; amendments agreed to, disagreed to, amended and agreed to, Message to Council, 390; Council does not insist on amendment, but proposes one in lieu thereof, agrees to Assembly's amendment on Council's amendment, insists on amendment, and does not insist on amendment, 417; motion made for consideration in Committee of the Whole of Message, and amendment moved ( <i>Mr. Dibbs</i> ), and negatived, to lay Bill aside, 425; Speaker ruled amendment of Council did not infringe on Assembly's rights, 426; further considered, agrees to amendment, and does not insist upon disagreement to amendment, Message to Council, 425; Assent reported, 461.	6	1107

REFERENCES TO THE VOTES AND PROCEEDINGS, VOL. I.—13TH PARLIAMENT—SESSION, 1887-8.	PAPERS.	
	VOL.	PAGE.
<b>G</b>		
GOVERNOR :—		
Message from, delivered by Usher of the Black Rod, 1, 642.		
Opening Speech, 2; Address in Reply, 3, 4; Answer to Address, 5.		
Prorogation Speech, 643.		
“GRACE, EDWARD” (See “CROWN LANDS PURCHASES VALIDATION BILL”).		
“GRADY, CORNELIUS” (See “CROWN LANDS”).		
GRAFTON (See “ELECTORAL”).		
GRAFTON SCHOOL OF ARTS TRUSTEES ENABLING BILL :—		
Petition presented ( <i>Mr. See</i> ) for leave to bring in, 174; leave given, presented and read 1 <sup>o</sup> , 181; referred to Select Committee, 185; Report brought up, 224; Order of the Day postponed, 325, 369; read 2 <sup>o</sup> , committed, reported without amendment, report adopted, 507; Order of the Day postponed, 593, 628.	2	919
GRAIN (See “AGRICULTURAL PRODUCTS”).		
GRANT, ALEXANDER OGILVIE (See “HUNTER-STREET, NEWCASTLE, EXTENSION BILL”).		
GRANTS (See “ORIGINAL GRANTS OF LAND BOUNDARIES BILL;” see also “ROADS”).		
GRANVILLE (See “RAILWAYS”).		
GRATUITIES (See “CIVIL SERVICE”).		
GREAT NORTHERN AND NORTH-WESTERN RAILWAYS (See “RAILWAYS”).		
GREVILLE (See “TERALBA COAL-MINING RESERVE”).		
“GULCHER” MACHINE (See “ELECTRIC LIGHT”).		
GUNNEDAH (See also “ROADS”; also “BY-LAWS”) :—		
OSRIC-STREET :—		
Motion made ( <i>Mr. Goodwin</i> ) for all correspondence respecting the flooding of, by a railway drain, with all reports, plans, &c., relating to same, 22; Return to Order, laid on Table, 122 .....	6	1077
“GUTHRIE,” S.S. :—		
Return respecting Chinese passengers by, laid on Table, 454 .....	2	211
GUYRA (See “RAILWAYS”).		
GWYDIR ELECTORATE (See “ELECTORATES OF THE GWYDIR AND INVERELL BOUNDARIES AMENDMENT BILL”).		
<b>H</b>		
“HANSARD” :—		
DAILY :—		
Motion made ( <i>Mr. Carruthers</i> ) for adoption of Report from Select Committee of last Session, and negatived, 88.		
SHORTHAND WRITING SERVICES :—		
Motion made ( <i>Mr. Walker</i> ) for a Return showing amount paid for, in connection with Commissions and Boards of Inquiry since 1st January, 1886, and the number and name of Commissions and Boards of Inquiry attended by staff of, 232.		
HARBOURS (See also “PARLIAMENTARY STANDING COMMITTEE ON PUBLIC WORKS”).		
TRUSTS :—		
Motion made ( <i>Mr. Martin</i> ) that the Government should immediately resume the whole of the wharf and foreshores requisite at Port Jackson and at Port Hunter, Newcastle, with a view to form, with large powers, and by leave withdrawn, 59.		
DEFENCE :—		
Correspondence respecting Major Parrott’s Report on Coast and, laid on Table, 84.....	2	63
AND RIVERS DEPARTMENT :—		
Motion made ( <i>Mr. Frank Farnell</i> ) for return of officers, length of service and pay, and the number of articulated pupils and their rates of pay, 500; Return to Order, laid on Table, 635...	2	119
HARDEN RAILWAY STATION :—		
Motion made ( <i>Mr. Gordon</i> ) for return of goods and passenger traffic, and revenue and expenditure at, 294; Return to Order laid on Table, 338 .....	6	741
HARRISON JOHN (See “CROWN LANDS”).		
HASSALL, MR. :—		
MEMBER FOR THE GWYDIR :—		
Declared guilty of persistent disorder and removed by the Sergeant-at-Arms from the Chamber, 220.		
HAUGHTON AND PALMER (See “MINING”).		
HAY AND DENILQUIN TRAMWAY BILL :—		
Petition presented ( <i>Mr. R. B. Wilkinson</i> ) to proceed with Bill under 65th Standing Order, 21; presented and read 1 <sup>o</sup> , 22; motion made for 2 <sup>o</sup> , and debate adjourned, 77; debate resumed and 2 <sup>o</sup> negatived, 145.		
HAYNES, JOHN, ESQUIRE, M.P. :—		
Motion made ( <i>Mr. Melville</i> ) to refer to Elections and Qualifications Committee, to report whether the Seat of, as a Member for Mudgee, has not and is not now vacant by reason of his becoming a bankrupt or insolvent debtor, and negatived, 145;		
A MEMBER FOR MUDGEE :—		
Assaulted whilst addressing the Chair by Mr. Fletcher, 345.		
PRIVILEGE :—		
Mr. Melville called attention to speech reported in the <i>Australian Star</i> and moved that the statement be read by the Clerk, 364; Statement read by the Clerk, and motion made ( <i>Mr. Melville</i> ) censuring the Honorable Member, and negatived, 365.		
HEALTH BOARD (See “RABBIT PEST”; also “TYPHOID FEVER”).		
HELLMRICH, MR. CHARLES (See “ELECTORAL”).		
HERREN, MICHAEL (See “CROWN LANDS PURCHASES VALIDATION BILL”).		
HOGAN, PATRICK (See “CROWN LANDS PURCHASES VALIDATION BILL”).		
HOLDSWORTHY (See “EDUCATION”).		
HOMEBUSH (See “RAILWAYS”).		
HOPKINS, W. A. (See “ADMINISTRATION OF JUSTICE”).		
HORSES (See “TELEGRAPHS”).		
HOSPITALS :—		
PATIENTS RECEIVED INTO, FROM PUBLIC WORKS :—		
Return to Order ( <i>Second Session 1887</i> ), laid on Table, 6; referred to Select Committee on “Deductions from wages of employes for medical attendance,” 462 .....	4	781
PRINCE ALFRED :—		
Motion made ( <i>Mr. Hassall</i> ) for all correspondence between the University and W. C. Wilkinson, Esq., M.P., relative to appointment of Pathologist or Physician to, 231; Return to Order, laid on Table, 257 .....	4	775

REFERENCES TO THE VOTES AND PROCEEDINGS, VOL. I—13TH PARLIAMENT—SESSION, 1887-8.	PAPERS.	
	VOL.	PAGE.
<b>H</b>		
HOUR OF MEETING (See "ASSEMBLY").		
HOUSES OF PARLIAMENT (See "PARLIAMENT").		
HULBERT, THE REV. DANIEL P.M. :—		
Petition from, that for 39 years he was in the direct pay of Her Imperial Majesty and for over 30 years occupied the position of Stipendiary Pastor in Goulburn Church District, but has not received the revenues of the office, and praying the appointment of a Select Committee for investigation, presented, 144 .....	8	1299
Petition presented from, in opposition to the Church of England Property Bill, 560 .....	2	899
HUNTER RIVER DISTRICT (See "CASTINGS FOR HUNTER RIVER DISTRICT").		
HUNTER-STREET NEWCASTLE EXTENSION BILL :—		
Petition presented ( <i>Mr. Fletcher</i> ) for leave to bring in, 287; leave given, presented, and read 1 <sup>o</sup> , 294; referred to Select Committee, 308; report brought up, 429 .....	2	925
Petition presented ( <i>Mr. Ellis</i> ) Ratepayers of Newcastle in favour of passing, 325 .....	2	943
Petition presented ( <i>Mr. Ellis</i> ) Rev. Sydney Calvert Jackson Grime, Frances his wife, William Howard Greenway, and Charles Sweetland against the Bill or to restrict the provisions of, 325 .....	2	941
Petition presented ( <i>Mr. Hassall</i> ) from Alexander Ogilvie Grant, of Parramatta, against the Bill as it stands, 369 .....	2	945
Petition presented ( <i>Mr. Hassall</i> ) Alexander Ogilvie Grant, of Parramatta, for leave to appear at the Bar of the House, by Counsel or Attorney, against the Bill, 369 .....	2	947
Petition presented ( <i>Mr. Levien</i> ) from Alexander Ogilvie Grant, of Parramatta, for leave to appear by Counsel or Attorney before the Select Committee on the Bill, 385; leave granted, 417 .....	2	949
HURSTVILLE (See "RAILWAYS").		
HUSBAND, JAMES H., CLAIM OF :—		
Return to Order ( <i>Second Session</i> , 1887), laid on Table, 257 .....	8	1033
HYDRAULIC POWER (See "SYDNEY HYDRAULIC POWER COMPANY'S BILL"; also "SYDNEY AND SUBURBAN HYDRAULIC POWER COMPANY'S BILL").		
<b>I</b>		
IMMIGRATION (See also "STATISTICS"; also "CHINESE") :—		
Report for 1887 laid on Table, 352 .....	2	159
Further Returns to Addresses, laid on Table,—Steamship "Oroya," 6; Steamship "Liguria," 144; Steamship "Orient," 257 .....	2	165, 167 169
CHINESE :—		
Further Correspondence respecting, laid on Table, 369 .....	2	203
Ministerial Statement by Sir Henry Parkes, 364, 451.		
Petition presented ( <i>Mr. Haynes</i> ) from Chinese residents upon the subject, and read by the Clerk, 454 .....	2	225
Motion made ( <i>Mr. Dibbs</i> ), (Vote of Censure,) condemning acts of Government in reference to, 468, and negatived, 469.		
IMPERIAL CONFERENCE (See "COLONIAL CONFERENCE IN LONDON, 1887").		
IMPORT DUTIES (See "FINANCE").		
IMPORTED STOCK ACTS :—		
Regulation under, laid on Table, 6 (2), 257, 524 .....	8	637, 639, 641, 651
IMPORTS (See "STATISTICS").		
IMPROVEMENT (See "CROWN LANDS").		
INDUSTRIAL SCHOOL FOR GIRLS, PARRAMATTA :—		
Amended Regulations under Industrial Schools Act of 1866, laid on Table, 155 .....	4	521
INFECTIOUS DISEASES (See "ANIMALS INFECTIOUS DISEASES BILL").		
INFIRM AND DESTITUTE (See "ASYLUMS, GOVERNMENT").		
INLAND WATERS FISHERIES BILL :—		
Motion made ( <i>Mr. Tonkin</i> ) for leave to bring in, 70; presented and read 1 <sup>o</sup> , 84; read 2 <sup>o</sup> , committed, reported with amendments, and report adopted, 192; read 3 <sup>o</sup> , passed, and sent to Council, 196; returned with amendments, 247; amendments agreed to, 248; Assent reported, 249.		
INSANE :—		
Report of the Inspector-General for 1887, laid on Table, 429 .....	4	635
INSCRIBED STOCK ACT OF 1883 :—		
Fifth Report on the Creation, Inscription, and Issue of Stock under, laid on Table, 257 .....	3	505
INSCRIBED STOCK (See "FINANCE").		
INSOLVENT DEBTOR (See "PRIVILEGE").		
INSOLVENCY (See also "BANKRUPTCY BILL"; also "BANKRUPTCY ACT AMENDMENT BILL") :—		
PETITIONS FOR LEAVE TO SURRENDER ESTATES IN :—		
Motion made ( <i>Mr. Cameron</i> ) for a return showing number presented since the appointment of Alfred M'Farland, Esq., as Deputy Commissioner, with particulars as to mode of dealing with them, 52.		
INSTRUCTION (See "EDUCATION").		
INTERRUPTION :—		
To debate, 76, 253, 303, 308.		
To Proceedings of the House by interjection by Mr. Thomas Robertson, 79.		
To Proceedings, 296, 349.		
INTOXICATING DRINK :—		
INQUIRY COMMISSION :—		
Report ( <i>first part</i> ), with Minutes of Evidence and Appendices, laid on Table, 6 .....	7	1
SALE OF, IN PARLIAMENTARY BUILDINGS :—		
Motion made ( <i>Mr. Thompson</i> ) that the practice of, be at once discontinued, and negatived, 59.		
INVENTIONS :—		
Letters of Registration of, for 1883 and 1884, laid on Table, 191, 420 .....	9	1
INVERELL (See "RAILWAYS"; also "ELECTORATES OF THE GWYDIR AND INVERELL BOUNDARIES AMENDMENT BILL").	10	1
INVESTMENT, BANKING, LAND, AND BUILDING COMPANIES :—		
General Summary of Liabilities and Assets for quarter ended 31st March, 1888, laid on Table, 475 .....	3	849
IRBY, EDWARD. (See "RAILWAYS").		
IRON COVE BRIDGE. (See "BRIDGES").		
IRON AND STEEL RAILWAY AND TRAMWAY MATERIALS (See "RAILWAYS"; also "TRAMWAYS").		
IRON TELEGRAPH POLES (See "TELEGRAPHS")		
IRVING, JAMES (See "CROWN LANDS").		

REFERENCES TO THE VOTES AND PROCEEDINGS, VOL. I—13TH PARLIAMENT—SESSION, 1887-8.	PAPERS.	
	VOL.	PAGE.
<b>J</b>		
JENKINS, MR. L. C. (See "RAILWAYS").		
JOACHIM FAMILY (See "CROWN LANDS"; also "CROWN LANDS PURCHASES VALIDATION BILL").		
JONES, STEPHEN W., ESQ. :— Retirement of, from position of Clerk of Legislative Assembly, 250.		
JUBILEE (See also "ADDRESS"; also "ADELAIDE JUBILEE INTERNATIONAL EXHIBITION") :— COINAGE :— Despatch respecting, laid on Table, 5, 356 .....	8	1,219, 1,221
JUDGES ENABLING BILL :— Received from Legislative Council, and on motion ( <i>Mr. Wise</i> ) read 1 <sup>o</sup> , 185; Standing Orders suspended, 191; read 2 <sup>o</sup> , committed, reported without amendment, report adopted, read 3 <sup>o</sup> , passed, and returned to Council without amendment, 197.		
JUDGES OF LIVE STOCK (See "RAILWAYS").		
JUDGMENT CREDITORS REMEDIES EXTENSION BILL :— Motion made ( <i>Mr. Trickett</i> ) for leave to bring in, 58; presented and read 1 <sup>o</sup> , 59; Order of the Day postponed, 107, 147, 151, 234, 416; read 2 <sup>o</sup> , committed, reported without amendment, report adopted, 508; read 3 <sup>o</sup> , passed, and sent to Council, 513; returned without amendment, 626; Assent reported, 630.		
JUVENILE OFFENDERS :— Motion made ( <i>Mr. Thompson</i> ) for a return, in continuation of a previous one, up to 30th June, 1887, 97; Return to Order, laid on Table, 165 .....	2	707
<b>K</b>		
KAHIBAH (See "CROWN LANDS"; also "MINING").		
KENNY HILL (See "WATER SUPPLY").		
KENT-STREET ROMAN CATHOLIC CHURCH LAND SALE BILL :— Received from Legislative Council, and on motion ( <i>Mr. Day</i> ) read 1 <sup>o</sup> , 152; motion made for 2 <sup>o</sup> , amendment moved to refer to Select Committee and withdrawn, read 2 <sup>o</sup> , committed, reported with amendments and report adopted, 193; read 3 <sup>o</sup> , passed, and returned to Council with amendments, 196; amendments agreed to, 200; assent reported, 237.		
KIAMA (See "ELECTORAL").		
KIAMA TRAMWAY ACT AMENDMENT BILL :— Petition presented ( <i>Mr. Cameron</i> ), 302; leave given, presented, and read 1 <sup>o</sup> , 377; referred to Select Committee, 314; Report brought up, 369, read 2 <sup>o</sup> , committed, reported without amendment, report adopted, 430; read 3 <sup>o</sup> , passed and sent to Council, 432; returned without amendment, 547; Assent reported, 555.	2	951
KIDMAN & SONS AND JAMES KIDMAN :— Statement of Amount of Money paid to, under various Contracts, from 1876 to 1887 inclusive, laid on Table, (not printed) 403.		
KINGSBURY & CO (See "TELEGRAPHS").		
KURNELL :— PARK RESERVE AT BOTANY BAY :— Motion made ( <i>Mr. Carruthers</i> ) that immediate steps be taken to secure a sufficient area as, adjacent to the place where Captain Cook first landed in Australia, and withdrawn, 232.		
<b>L</b>		
LABOUR BUREAU, CASUAL :— Return respecting, laid on Table, 35 .....	8	1027
LABOUR HOURS (See "EIGHT HOURS BILL").		
LACHLAN RIVER (See "CONSERVATION OF WATER").		
LAKE MACQUARIE HARBOUR WORKS :— Report (with plans) by Sir John Cooke, K.C.M.G., M.I.C.E., laid on Table, 324 .....	3	895
LAND (See also "RAILWAYS"; also "GOVERNMENT"; also "CROWN LANDS") :— PURCHASE BY THE GOVERNMENT OF, BETWEEN A.S.N. CO.'S WHARF AND DAWES POINT :— Motion made ( <i>Mr. Melville</i> ) for Select Committee to inquire into, Committee appointed by ballot, 30; Report brought up, 305 .....	3	917
Correspondence respecting, laid on Table, and referred to Select Committee, 52 .....	3.	1011
Motion made ( <i>Mr. Dibbs</i> ) for an address to the Governor, censuring Government for, and negatived, 329.		
HELD BY THE HON. JOHN SMITH, IN THE DISTRICT OF MOLONG :— Motion made ( <i>Dr. Ross</i> ), for a Return showing, under Orders in Council, area of each portion and why granted, 155; Return to Order, laid on Table, 219 .....	5	445
SALE OF IN PARISH OF MOLONG, COUNTY OF ASHBURNHAM :— Motion made ( <i>Dr. Ross</i> ) for address to Governor for correspondence, plans, Judges decision, and ruling, &c., 479.		
LAND TAX BILL :— Message from Governor, 234, Resolution reported from Ways and Means and agreed to, Ordered ( <i>Mr. Burns</i> ) founded on Resolution of Ways and Means, presented and read 1 <sup>o</sup> , 430; motion made for 2 <sup>o</sup> and debate adjourned, 496; read 2 <sup>o</sup> and committed, 501; further considered in Committee, 520, 532; further considered, and reported with amendment, 538; report adopted, 544; Order of the Day postponed, 561, 573; amendment negatived to reconsider clauses 1, 2, and 15, recommitted to consider clause 59, 586; further amended, reported 2 <sup>o</sup> , Speaker ruled amendment in order, report adopted, 587; read 3 <sup>o</sup> , passed, and sent to Council, 593.	3	835
Petition from J. C. Neild, Mayor of Woollahra, representing that the provisions in regard to lands held in fee simple and lands held under lease are manifestly inequitable, read by the Clerk, 579.	3	837
LAND TITLES. (See "REAL PROPERTY ACT").		

REFERENCES TO THE VOTES AND PROCEEDINGS, VOL. I—13TH PARLIAMENT—SESSION 1887-8.	PAPERS.
	VCL. PAGE.
<b>L</b>	
<b>LANDS FOR PUBLIC PURPOSES ACQUISITION ACT:—</b>	
<b>NOTIFICATIONS OF RESUMPTIONS UNDER, LAID ON TABLE:—</b>	
Public Parks, 6 .....	5 827
Military Road, South Head to Ben Buckler and Bondi, 22 .....	2 65
Road along Main Sewer to Bondi, from Old South Head Road to Forts at Bondi, 22 .....	5 1019
Public School purposes, 70, 155, 246, 257, 341, 360, 408, 495, 553, 603 .....	4 525 to 545
Water Supply purposes, 5, 165, 613 .....	5 871 to 875
Extension of Parramatta Gaol, 231 .....	4 1227
Public Cemetery at Singleton, 252 .....	8 1223
Gazette Notice setting forth resumption under 6th section, 314 .....	5 683
Daysdale Tank, 415 .....	8 951
Public Wharf near Frederickton, Macleay River, 432 .....	3 1049
Public Wharf near Ghinny Ghinny, Manning River, 475 .....	3 1051
Sydney Sewerage Works, 613 .....	5 877
<b>LANDS OFFICE, SYDNEY:—</b>	
Return respecting Tenders for completion of, laid on Table, 635 .....	5 99
<b>LANE FAMILY</b> (See "TERALBA COAL-MINING RESERVE").	
<b>LEASEHOLD AREAS</b> (See "CROWN LANDS").	
<b>LEAVE OF ABSENCE:—</b>	
Granted to Member of the Legislative Assembly, 17, 112, 308, 361, 437.	
Do Chairman of Committees, 397, 424.	
<b>LEESON, MR.</b> (See "TELEGRAPHS").	
<b>LEGAL PRACTITIONERS BILL:—</b>	
Motion made ( <i>Mr. Walker</i> ) for leave to bring in, presented, and read 1 <sup>o</sup> , 128; Order of the Day postponed, 252, 288, 365, 506, 579.	
<b>LEGISLATIVE COUNCIL:—</b>	
Motion made ( <i>Mr. Walker</i> ) that one Chamber is all that is necessary for the proper transaction of Parliamentary Business, that the Legislative Council is useless and dangerous, and ought to be abolished, and withdrawn, 36.	
<b>LEICHHARDT COUNCIL CHAMBERS (MORTGAGE) BILL:—</b>	
Petition presented ( <i>Mr. Hawthorne</i> ) for leave to bring in, 107; leave given presented and read 1 <sup>o</sup> 122; referred to Select Committee, 128; Report brought up, 145; read 2 <sup>o</sup> , committed, reported without amendment, and report adopted, 233; read 3 <sup>o</sup> , passed, and sent to Council, 236; returned without amendment, 258; assent reported, 311.	2 957
<b>LEONARD AND BATHGATE'S CANCELLED CONTRACTS</b> (See "ROADS").	
<b>LEPROSY AT HONOLULU</b> (See "ADJOURNMENT").	
<b>LETTER SORTERS AND CARRIERS</b> (See "POSTAL").	
<b>LEVIEN MR.:—</b>	
<b>A MEMBER FOR TAMWORTH:—</b>	
Declared guilty of persistent disorder and removed by Sergeant-at-Arms from the Chamber, 221.	
<b>LIBRARY COMMITTEE:—</b>	
Sessional Order passed, 11.	
Name added to, 89.	
<b>LICENSED SURVEYORS:—</b>	
Motion made ( <i>Mr. McElhone</i> ) for returns of uncompleted instructions in hands of, the names and district, the names of those who employ assistants, the number employed, and the total number employed and unemployed, 378.	
<b>LICENSE FEES</b> (See "CROWN LANDS").	
<b>LICENSES</b> (See also "LOCAL OPTION.")	
<b>LICENSING ACT:—</b>	
Motion made ( <i>Mr. Jones</i> ) for a return showing, revenue derived under from rights granted or penalties inflicted, the annual cost of administration, the annual cost of administration of Justice, the annual cost by reason of the existence of the Liquor Traffic, the number of convictions, and of individuals convicted of drunkenness, 23; Return to Order, laid on Table, 476 .....	7 679
<b>EMPLOYMENT OF BARMAIDS IN PUBLIC HOUSES:—</b>	
Petition from Women's Christian Temperance Union and others, to amend the law so as to prohibit, presented, 22 .....	7 711
<b>PRIVATE BARS IN PUBLIC HOUSES:—</b>	
Motion made ( <i>Mr. Henson</i> ) that the system of, is an evil, the Government should at once take steps to suppress; Previous Question moved and negatived, 165.	
<b>CONVICTIONS UNDER:—</b>	
Motion made ( <i>Mr. Henson</i> ) for additional information, 506.	
Spirits, wines, and beer—Annual Return to Order, laid on Table, 560 .....	7 681
<b>LIENS ON WOOL BILL:—</b>	
Motion made ( <i>Mr. J. P. Abbott</i> ) for a Committee of the Whole, 40; Order of the Day postponed, 65; House in Committee and Resolution agreed to, 107;	
<b>LIGHTERING, DELIVERING, AND STORING OF EXPLOSIVES:—</b>	
Amended Rates and Charges for, laid on Table, 280 .....	8 1207
<b>LIGHTHOUSE</b> (See "MACQUARIE LIGHTHOUSE").	
<b>LIMITED EXPRESS TRAIN</b> (See "RAILWAYS").	
<b>LIQUOR</b> (See "COMMISSION," also "LICENSING ACT").	
<b>LIQUOR TRAFFIC (LOCAL VETO) BILL:—</b>	
Motion made ( <i>Mr. Hutchinson</i> ) for leave to bring in, 344; presented and read 1 <sup>o</sup> , 345; Order of the Day discharged, 389.	
<b>PETITIONS PRESENTED</b> , representing that enormous evils everywhere result from the traffic in intoxicating liquors, and praying the House to pass the Bill:—	
From Alexander Gow, Chairman of Local Option League, 386 .....	695
"Light of the Valley" Lodge, Lithgow, 432 .....	
"Excelsior Lodge," No. 279, Jamberoo, 432 .....	
"Beacon of Light" Lodge, Wollongong, 432 .....	697
"Miners' Friend" Lodge, Fairy Meadow, 432 .....	
"Northern Star" Lodge, Lismore, 451 .....	
"Hope to Save" Lodge, Lismore, 451 .....	
"Pride of the Richmond" Lodge, Rous, 451 .....	
"Minnchaha" Lodge, Lismore, 451 .....	
"Victoria" Lodge, Armidale, 451 .....	
"Hope of Saumarez" Lodge, Saumarez Ponds, 451 .....	
"Lachlan" Lodge, Forbes, 451 .....	
"Hopeful" Lodge, Condobolin, 451 .....	699

REFERENCES TO THE VOTES AND PROCEEDINGS, VOL. I—13TH PARLIAMENT—SESSION 1887-8.	PAPERS.	
	VOL.	PAGE.
<b>L</b>		
<b>LIQUOR TRAFFIC (LOCAL VETO) BILL—(continued) :—</b>		
<b>PETITIONS PRESENTED—(continued) :—</b>		
From "Guiding Star" Lodge, Wellington, 451 .....	}	690
Public Meeting of Residents in and about Balmain, 451 .....		
"Alexander Hutchison" Lodge, Newcastle, 451 .....		
"W. S. Reay" Lodge, Bredalbane, 454 .....		
"Evening Star" Lodge, Parramatta, 462 .....		
"Rock of Refuge" Lodge, Maclean, Clarence River, 462 .....		
No. 96 Lodge, Milton, 462 .....		
"Pride of Austinmer" Lodge, Austinmer, 462 .....		
"Happy Dawn" Lodge, Araluen, 462 .....		
Certain residents of Tingha, 467 .....		
"Flower of the Forest" Lodge, Kangaloon, 467 .....		
"Enemy of Alcohol" Lodge, Werombi, near Camden, 467 .....		
"Sherwood Rangers" Lodge, Goughtown, 467 .....		
"Temple of Good Hope" Lodge, Tenterfield, 467 .....		
"Princess Beatrice" Lodge, Newtown, 467 .....		
"Rescue" Lodge, Parkes, 467 .....		
"Pride of Rooty Hill" Lodge, Rooty Hill, 467 .....		
"Union is Strength" Lodge, Wiseman's Creek, 467 .....		
"Hearts of Oak" Lodge, Waverley, 467 .....		
"Alexandria" Lodge, St. Mark's, Darling Point, 467 .....		
"Southern Cross" Division, Kiama, 467 .....		
Certain residents of Wagga Wagga and surrounding Districts, 467 .....		
"Try Again" Lodge, Hillston, 467 .....		
"Ark of Refuge" Lodge, Cobar, 467 .....		
"Union of the East" Lodge, Eastgrove, Goulburn, 467 .....		
"Eureka" Lodge, Gunning, 467 .....		
"Hope of Wilcannia" Lodge, Wilcannia, 467 .....		
"Golden Chain" Lodge, Petersham, 467 .....		
"Dawn of Day" Lodge, Goulburn, 467 .....		
"Reunion" Lodge, Upper Botany, 475 .....		
"Star of the South" Lodge, Cooma, 475 .....		
"Hope of Walcha" Lodge, Walcha, 475 .....		
"Hope of Hastings" Lodge, Port Macquarie, 475 .....		
"Haste to the Rescue" Lodge, Balmain, 475 .....		
"Excelsior" Lodge, Clarence Town, 475 .....		
"Pride of Bungawalbyn" Lodge, Bungawalbyn, 475 .....		
"Wardell Hope" Lodge, Wardell, 475 .....		
"Star of Hope" Lodge, Chatsworth, Clarence River, 475 .....		
"Rose of Dryaaba" Lodge, Lawrence, Clarence River, 475 .....		
"Pride of Minmi" Lodge, Minmi, 475 .....		
"Perseverance" Lodge, Hay, 475 .....		
"Unity" Lodge, St. Paul's, Redfern, 475 .....		
"Victoria" Lodge, Collector, 478 .....		
"Joseph Livesay" Lodge, Randwick, 478 .....		
"Friendship Division," No. 10, Lismore, 478 .....		
"Centennial" Lodge, Marulan, 478 .....		
"Universal" Lodge, Castle Hill, 478 .....		
"Star of the East" Lodge, Field of Mars, 478 .....		
"Harvest Home" Lodge, Tamworth, 478 .....		
"Hope of Coolangatta" Lodge, Coolangatta, Shoalhaven, 484 .....		
"Star of Moruya" Lodge, Moruya, 484 .....		
"Hope of Molong" Lodge, Molong, 492 .....		
The "W. E. Gladstone" Lodge, Mount Keira, 492 .....		
"Glen Morrison" Lodge, Glen Morrison, 492 .....		
"Star of Young" Lodge, Young, 492 .....		
"Pride of Moss Vale" Lodge, Moss Vale, 492 .....		
"Hope of Bundanoon" Lodge, Bundanoon, 492 .....		
"Gordon" Lodge, Bowral, 492 .....		
"Rose of Marrickville" Lodge, Marrickville, 492 .....		
"Life Buoy" Lodge, Gundurimba, 492 .....		
"Star of Oberon" Lodge, Oberon, 493 .....		
"Want Supplied" Lodge, Bingera, 493 .....		
"Currabubula United" Lodge, Currabubula, 493 .....		
Good Templars, Walgett, 496 .....		
"Olive Branch" Lodge, Kinchela, 500 .....		
"Ark of Safety" Lodge, Orange, 560 .....		
"Star of Peace" Lodge, Spring Terrace, 560 .....		
Public Meeting held in Bathurst, 538 .....		707 709
<b>LISMORE</b> (See also "CROWN LANDS") :—		
<b>WATER SUPPLY :—</b>		
Notification of resumption of certain land, required in connection with the construction of works for, 5 .....	5	871
<b>LISTER J. H. A.</b> (See "MINING").		
<b>LITTLE BAY</b> (See "COAST HOSPITAL, LITTLE BAY.")		
<b>LIVERPOOL CHURCH OF ENGLAND GRAMMAR SCHOOL LAND SALE BILL :—</b>		
Petition presented ( <i>Mr. Nobbs</i> ) for leave to bring in, 386; leave given, presented, and read 1 <sup>o</sup> , 389; referred to Select Committee, 397; report brought up, 409; Order of the Day postponed, 479, 593, 608, 613, 619.	2	965
<b>LIVERPOOL-ST. PETER'S LINE</b> (See "RAILWAYS").		
<b>LIVE STOCK :—</b>		
Return of, in Australasian Colonies, 1871, 1881, and 1887, laid on Table, 565 .....	8	597
<b>LOAN ESTIMATES</b> (See "FINANCE").		
<b>LOANS</b> (See "FINANCE," also "MUNICIPAL LOANS BILL," also "REPAYMENT OF LOANS BILL," also "PUBLIC WORKS LOAN BILL").		
<b>LOCAL AND NATIONAL WORKS :—</b>		
Statement of Expenditure on, in the Colony, from 1860 to 1886, laid on Table, 28 .....	8	1231
<b>LOCAL GOVERNMENT BILL</b> (See "DISTRICT GOVERNMENT BILL").		



REFERENCES TO THE VOTES AND PROCEEDINGS, VOL. I—13TH PARLIAMENT—SESSION, 1887-8.	PAPERS.	
L	VOL.	PAGE.
LOCAL OPTION (See also "LIQUOR TRAFFIC (LOCAL VETO) BILL"). Motion made ( <i>Mr. Hutchison</i> ) that a legal power of restraining the issue or renewal of licenses should be placed in the hands of those most interested, who are entitled to protection from injurious consequences of the present system by some efficient measure of, 24; Petition that a veto power as to granting new licenses or the renewal of old ones be conceded in any amending Licensing Act, presented, 35 .....	7	693
VOTE IN METROPOLITAN AND SUBURBAN MUNICIPALITIES :— Return showing result of, taken in February, 1888, laid on Table, 524 .....	7	689
LOCOMOTIVE ENGINES (See "RAILWAYS").		
LODGING-HOUSES BILL (See "COMMON LODGING-HOUSES BILL").		
LUCAS, SURVEYOR, CHARGES AGAINST :— Motion made ( <i>Mr. McElhone</i> ) for papers in connection with, 578.		
LYNE MR. :— A MEMBER FOR THE HUME :— Declared guilty of persistent disorder and removed by Sergeant-at-Arms from the Chamber, 221.		
<b>M</b>		
MACGREGOR, WILLIAM PETER, ESQ., M.P. :— Resignation of, as a Member for Wentworth, reported, 1.		
MACKRELL, ROBERT. CONDITIONAL PURCHASE OF (See "CROWN LANDS").		
MACLEAN (See PRESBYTERIAN CEMETERY AT MACLEAN").		
MACQUARIE LIGHTHOUSE :— ELECTRIC LIGHTING :— Motion made ( <i>Mr. Wall</i> ) for correspondence between the Colonial Architect and the Superintendent of Telegraphs, 267; Return to Order, laid on Table, 543 .....	4	1199
MAIL COMMUNICATION BETWEEN GREAT BRITAIN AND AUSTRALIA VIA SUEZ (See "POSTAL").		
MALONEY, MARY (See "CROWN LANDS").		
MANLY DRAINAGE WORKS (See "PARLIAMENTARY STANDING COMMITTEE ON PUBLIC WORKS").		
MANLY TRAMWAY BILL (See "NORTH SHORE, MANLY, AND PITTWATER TRAMWAY AND RAILWAY BILL").		
MANNING, MR., CORONER, AT RYDE (See "ADMINISTRATION OF JUSTICE").		
MANSFIELD, JOHN :— Report and evidence in connection with the Fatal Accident to, at the Northumberland colliery, 475	8	249
MANUFACTORIES (See also "STATISTICS").		
IMPORT DUTIES ON ARTICLES LOCALLY MANUFACTURED :— Motion made ( <i>Mr. Copeland</i> ) for, and on agricultural productions grown in the Colony, and the Question not being put at 7 o'clock, Government business takes precedence, 493.		
MARKETS (See "FOREIGN MARKETS FOR WOOL AND MEAT").		
MARKS (See "MERCHANDISE MARKS BILL").		
MASTERS AND MATES :— Despatch respecting Applications for Certificate of Competency, laid on Table, 475 .....	8	1015
MAXWELL ANN (See "ADMINISTRATION OF JUSTICE").		
MAYORAL ELECTION (See "CITY OF SYDNEY MAYORAL ELECTION BILL").		
McBEAN JOHN (See "MINING").		
McCARRAN, EDWARD :— Report and evidence in connection with the Fatal Accident to, at the West Wallsend colliery, laid on Table, 475... ..	8	259
McCULLOCH, ANDREW HARDIE, JUN., ESQ., M.P. :— Resignation of, as a Member for Central Cumberland reported, and seat declared vacant, 222, 419; issue and return of Writ reported, 249, 463; sworn, 253.		
McELHONE, JOHN, ESQ., M.P. :— Words of heat used by, withdrawn and apology made, 374. Disorderly words used by, reported from Committee of Supply, 452. Disorderly words used by, reported from Committee of Whole, 479; Ordered to attend in his place, Sergeant reported that after diligent search he had failed to find the Hon. Gentleman on the premises, committed to custody of Sergeant-at-Arms for contempt, and Speaker's warrant issued, 480; reported as in custody of Sergeant-at-Arms, 483; motion made in reference to discharging the Honorable Member from custody, Hon. Member admitted to Bar and made explanation and apology, and discharge authorized, Speaker directed Sergeant accordingly, 485, 486.		
McINTOSH EVAN, CONDITIONAL PURCHASE OF (See "CROWN LANDS").		
McIVOR MATHEW (See "MINING.")		
McKINLAY, JOSEPH FRANCIS (See "MINING").		
McNEILL, MESSRS. HUGH, AND PARTY (See "MINING").		
McSHARRY AND O'ROURKE (See "RAILWAYS").		
MEAT (See DISEASED ANIMALS AND MEAT BILL).		
MEDICAL ATTENDANCE (See "DEDUCTIONS FROM WAGES OF EMPLOYEES FOR MEDICAL ATTENDANCE").		
MEDICAL PRACTITIONERS (See "REGISTERED MEDICAL PRACTITIONERS BILL").		
MEDICINE AND SURGERY :— Motion made ( <i>Mr. Melville</i> ) for Select Committee to inquire into practice, law, and regulation of, 58.		
MEETING OF THE HOUSE :— Sessional Order passed, 10.		
HOOR OF :— Motion made ( <i>Mr. Seaver</i> ) that during remainder of Session, House meet at 4 o'clock instead of 3 o'clock as at present, and negatived, 224.		
MELBOURNE EXHIBITION (See "CENTENNIAL INTERNATIONAL EXHIBITION, MELBOURNE").		
MELVILLE, NINIAN, Esq., M.P. :— A MEMBER FOR NORTHUMBERLAND :— "Named" by Mr. Speaker for refusing to withdraw and apologize for words ruled as out of order, withdrew words and apologised, 184. Declared guilty of persistent disorder and removed by Sergeant-at-Arms from the Chamber, 220. Motion made for adjournment of House to consider attack on, by <i>Sydney Morning Herald</i> , 335. Appointed with three others to act temporarily as Chairman of Committees in the absence of the Member appointed to that office, 389. Mr. Speaker calls on, to act as Deputy Chairman for this day only, 397, 416, 429, 442, 451, 463, 479, 496, 506, 532, 543, 547, 560.		

REFERENCES TO THE VOTES AND PROCEEDINGS, VOL. I—13TH PARLIAMENT—SESSION, 1887-8.	PAPERS.	
	VOL.	PAGE.
<b>M</b>		
<b>MEMBERS</b> (See also "PAYMENT OF MEMBERS OF THE LEGISLATIVE ASSEMBLY"; also "ASSEMBLY"; also "PARLIAMENTARY REPRESENTATIVES ALLOWANCE BILL") :—		
Sworn, 76, 87, 249, 253 <sup>(?)</sup> , 303, 342, 463.		
Of Elections and Qualifications Committee sworn, 37 <sup>(?)</sup> .		
Leave of absence granted to, 17, 112, 308, 361, 437.		
"Named" by Mr. Speaker, 156 <sup>(?)</sup> , 184.		
Suspended for remainder of Sitting, 345.		
Motion made for, to be heard, 302 <sup>(?)</sup> .		
Name added to Select Committee, 89, 280.		
Name discharged from Select Committee, 432, 462.		
Declared guilty, of persistent disorder, and removed from Chamber, 220 <sup>(?)</sup> , 221 <sup>(?)</sup> .		
<i>Words of heat</i> , used by, 374.		
Motion made ( <i>Mr. Melville</i> ) for adjournment of House to consider an attack made in an article in the <i>Sydney Morning Herald</i> on an Honorable Member for Northumberland, 334.		
Committed to custody of Sergeant-at-Arms by Speaker's warrant, 480.		
In custody of Sergeant-at-Arms, 483.		
Discharged from custody, 486.		
Name substituted for another on Select Committee, 585.		
Attendance of, in Divisions and Counts-out .....	1	653
<b>MENINDIE</b> (See "BRIDGES").		
<b>MENMUIR, S.S.</b> :—		
Return respecting Chinese passengers by, laid on Table, 454. ....	2	211
<b>MERCANTILE BROKERS</b> :—		
Petition from Merchants and, praying to be regulated by enactment by issue of licenses, presented, 224. ....	8	1225
<b>MERCHANDISE MARKS BILL</b> :—		
Motion made ( <i>Mr. Wise</i> ) for Committee of the Whole, 352. Order of the Day postponed, 508.		
<b>MESSAGES</b> :—		
<b>TRANSMISSION OF, BETWEEN THE TWO HOUSES</b> :—		
Sessional Order passed, 11.		
<b>FROM THE GOVERNOR</b> :—		
Delivered by Usher of the Black Rod, 1, 642.		
1. Assent to Saint James Parsonage Land Leasing Bill ( <i>passed in last Session</i> ), 2.		
2. Bankruptcy Bill, 2. ....	2	729
3. District Government Bill, 34 .....	2	569
4. Government Railways Bill, 35 .....	6	1105
5. Crown Lands Bill, 49 .....	5	599
6. Supreme Court Appeals Act Amendment Bill, 135 .....	2	733
7. Public Works Bill, 135 .....	8	1259
8. Naval Force (Australasian Naval Force Bill), 157 .....	2	67
9. Crown Lands Bill (No. 2), 162 .....	5	603
10. Mining on Church and School Lands, 166 .....	8	541
11. Assent to Supreme Court Appeals Act Amendment Bill, 168.		
12. Assent to Church and Perkins Streets (Newcastle) Bill, 171.		
13. Assent to Borough of Balmain Wharves Bill, 171.		
14. Estimates of Expenditure for 1888 and Supplementary Estimates for 1887 and previous years, 200 .....	3	1
15. Assent to Bankruptcy Bill, 219.		
16. Assent to Royalty on Oysters Abolition Bill, 219.		
17. Assent to Municipal Roads and Streets Bill, 219.		
18. Assent to Country Towns Water and Sewerage Act Extension Bill, 219.		
19. Assent to Albury Cattle Sale-yards Bill, 219.		
20. Metropolitan Water and Sewerage Act Amendment Bill, 228 .....	5	879
21. Land Tax, 234 .....	3	835
22. Property Tax, 234 .....	3	839
23. Assent to Australasian Naval Force Bill, 237.		
24. Assent to Kent-street Roman Catholic Church Land Sale Bill, 237.		
25. Assent to Yass Roman Catholic Church Land Sale Bill, 239.		
26. Vote of Credit 241. ....	3	821
27. do (January), 241 .....	3	823
28. Assent to Inland Waters Fisheries Bill, 249.		
29. Assent to Consolidated Revenue Fund Bill, 250.		
30. Assent to Sydney Corporation Act Amendment Bill, 250.		
31. Assent to Wentworth Electorate Subdivision Bill, 250.		
32. Rabbit Pest Suppression Bill, 268 .....	8	981
33. Parliamentary Representatives Allowances Bill, 268 .....	1	885
34. Vote of Credit, 265 .....	3	825
35. Assent to Consolidated Revenue Fund Bill, 311.		
36. Assent to Leichhardt Council Chambers (Mortgage) Bill, 311.		
37. Animals Infectious Diseases Bill, 314 .....	8	665
38. Assent to Metropolitan Water and Sewerage Act Amendment Bill, 317.		
39. Assent to Conversion into Mining Conditional Purchases Validation Bill, 317.		
40. Vote of Credit, 345 .....	3	827
41. Assent to Consolidated Revenue Fund Bill (No. 3), 351.		
42. Mail Service between Great Britain and Australia, <i>via</i> Suez, 355 .....	4	1109
43. Assent to Animals Infectious Diseases Bill, 378.		
44. Formation of street north of the General Post Office, 383 .....	4	1141
45. Vote of Credit, 404 .....	3	829
46. Assent to Consolidated Revenue Fund Bill (No. 4), 419.		
47. Assent to Victorian Coal-mining Company's Extension Bill, 419.		
48. Circular Quay Land Sale and Dedication Bill, 420 .....	3	1019
49. Assent to Tattersall's Club Bill, 435.		
50. Chinese Restriction and Regulation Bill, 454 .....	2	227
51. Assent Government Railways Bill, 461.		
52. Assent to Distribution of Funds in Sempill's Estates Bill (No. 2), 461.		
53. Assent to Christian Chapel Lands Sale Bill, 461.		
54. Assent to Rockdale Municipality Naming Bill, 462.		
55. Vote of Credit, 477 .....	3	831
56. Amended Estimates for Departments under control of Colonial Secretary, 491 .....	3	259

REFERENCES TO THE VOTES AND PROCEEDINGS, VOL. I—13TH PARLIAMENT—SESSION 1887-8.	PAPERS.	
M	VOL.	PAGE.
MESSAGES—(continued) :—		
FROM THE GOVERNOR—(continued) :—		
57. Assent to Consolidated Revenue Fund Bill, 491.		
58. Assent to Public Works Bill, 492.		
59. Assent to Readhead Coal Mine Railway Act Extension Bill, 492.		
60. Assent to Australian Mutual Provident Society's Acts Amendment Bill, 524.		
61. Government Railways Act Amendment Bill, 539 .....	6	1107
62. Diseased Animals and Meat Bill, 539 .....	8	667
63. Assent to St. Thomas Church (Enfield) Lands Sale Bill, 539.		
64. Assent to Permanent Trustee Company of New South Wales Bill, 539.		
65. Assent to Vine Diseases Act Amendment, 540.		
66. Amended Estimates for Departments under control of Colonial Secretary, 545 .....	3	295.
67. Vote of Credit, 553 .....	3	833
68. Assent to Consolidated Revenue Fund Bill (No. 6), 555.		
69. Assent to Contractors' Debts Act Amendment Bill, 555.		
70. Assent to Kiama Tramway Act Amendment Bill, 555.		
71. Assent to Perpetual Trustee Company Bill, 555.		
72. Assent to Chinese Restriction and Regulation Bill, 585.		
73. Further Supplementary Estimates for 1887, and Additional Estimate for 1888, 610 .....	3	331
74. Further Additional Estimate for 1888, 610 .....	3	353
75. Additional Estimate on Account of Repayment of Loans, 610 .....	3	359
76. Loan Estimate for 1888, 610 .....	3	365
77. Assent to Government Railways Act Amendment Bill, 619.		
78. Assent to Criminal Law Amendment Bill, 626.		
79. Assent to Parramatta Church-street Amended Alignment Bill, 629.		
80. Assent to Circular Quay Land Sale and Dedication Bill, 629.		
81. Assent to Bankruptcy Act Amendment Bill, 629.		
82. Assent to Church and Schools Lands Mining Bill, 629.		
83. Assent to Crown Lands Purchases Validation Bill, 630.		
84. Assent to Companies Bill, 630.		
85. Assent to Municipal Loans Bill, 630.		
86. Assent to Judgment Creditors' Remedies Extension Bill, 630.		
87. Assent to Crown Lands Act Further Amendment Bill, 630.		
FROM ASSEMBLY TO COUNCIL :—		
Transmitting Sydney Corporation Act Amendment Bill, 48.		
Municipal Roads and Streets Bill, 49.		
Albury Cattle Sale Yards Bill, 49.		
Borough of Balmain Wharves Bill, 64.		
Bankruptcy Bill, 107.		
Country Towns Water and Sewerage Act Extension Bill, 1		
Church and Perkins Streets (Newcastle) Bill, 112.		
Wentworth Electorate Sub-division Bill, 136.		
Supreme Court Appeals Act Amendment Bill, 145.		
Yass Roman Catholic Church Land Sale Bill, 150.		
Royalty on Oysters Abolition Bill, 169.		
Inland Waters Fisheries Bill, 196.		
Rockdale Municipality Re-naming Bill, 208.		
Australasian Naval Force Bill, 210.		
Transmitting Metropolitan Water and Sewerage Act Amendment Bill, 232.		
Leichhardt Council Chambers (Mortgage Bill), 236.		
North Shore, Manly, and Pittwater Tramway and Railway Bill, 236.		
Victorian Coal-mining Company's Extension Bill, 237.		
Consolidated Revenue Fund Bill, 242.		
Government Railway Bills, 258.		
Conversion into Mining Conditional Purchases Validation Bill, 263.		
Consolidated Revenue Fund Bill (No. 2), 296.		
Redhead Coal-mine Railway Act Extension Bill, 325.		
Animals Infectious Diseases Bill, 335.		
Consolidated Revenue Fund Bill, 346.		
Distribution of Funds in Sempill's Estates Bill, 373.		
Public Works Bill, 380.		
Christian Chapel Lands Sale Bill, 389.		
Consolidated Revenue Fund Bill (No. 4), 409.		
Vine Diseases Act Amendment Bill, 422.		
Silverton Tramway Act Amending Bill, 425.		
Kiama Tramway Act Amendment Bill, 432.		
Chinese Restriction and Regulation Bill, 456.		
Consolidated Revenue Fund Bill (No. 5), 481.		
Companies Bill, 512.		
Divorce Extension Bill, 512.		
Bills of Sale Act Amending Bill, 513.		
Broken Hill and Suburban Gas Company's Bill, 513.		
Contractors Debts Act Extension Bill, 513.		
Judgment Creditors Remedies Extension Bill, 513.		
Parliamentary Representatives Allowance Bill, 549.		
Consolidated Revenue Fund Bill, 554.		
Crown Lands Purchases Validation Bill, 560.		
Circular Quay Land Sale and Dedication Bill, 567.		
Essex-street Alignment Bill, 567.		
Government Railways Act Amendment Bill, 573.		
Church and School Lands Mining Bill, 585.		
Land Tax Bill, 593.		
Crown Lands Act Further Amendment Bill, amendment proposed to add words to and negatived, 595.		
Bankruptcy Act Amendment Bill, 598.		
Parramatta Municipal Quarries Bill, 601.		
Parramatta Church-street Amended Alignment Bill, 602.		
Cooma Church of England Lands Sale Bill, 602.		
Municipal Loans Bill, 602.		
Appropriation Bill, 639.		
Repayment of Loans Bill, 640.		
Public Works Loans Bill, 640.		

REFERENCES TO THE VOTES AND PROCEEDINGS, VOL. I—13TH PARLIAMENT—SESSION, 1887-8.	PAPERS.
M	VOL. PAGE.
<b>MESSAGES (continued) :—</b>	
<b>FROM ASSEMBLY TO COUNCIL—(continued) :—</b>	
Returning Kent-street Roman Catholic Church Land Sale Bill, with amendments, 196.	
Judges Enabling Bill, without amendment, 197.	
Tattersall's Club Bill, 425.	
Perpetual Trustee Company Bill, with amendments, 505.	
Permanent Trustee Company of New South Wales Bill, without amendment, 524.	
St. Thomas Church (Enfield) Lands Sale Bill, without amendment, 524.	
Australian Mutual Provident Society's Acts Amendment Bill, without amendment, 512.	
Criminal Law Amendment Bill, without amendment, 598.	
Agreeing to amendments in Borough of Balmain Wharves Bill, 162.	
Municipal Roads and Streets Bill, 192.	
Sydney Corporation Act Amendment Bill, 243.	
Wentworth Electorate Subdivision Bill, 243.	
Inland Waters Fisheries Bill, 248.	
Metropolitan Water and Sewerage Act Amendment Bill, 308.	
Conversion into Mining Conditional Purchases Validation Bill, 309.	
Rockdale Municipalities Naming Bill, 417.	
Distribution of Funds in Sempill's Estate Bill (No. 2), 429.	
Public Works Bill, including an amendment in the Title, 463.	
Redhead Coal Mine Railway Act Extension Bill, 464.	
Vine Diseases Act Amendment Bill, 494.	
Circular Quay Land Sale and Dedication Bill, 626	
Bankruptcy Act Amendment Bill, 627.	
Church and School Lands Mining Bill, 627.	
Crown Lands Purchases Validation Bill, 627.	
Companies Bill, 628.	
Silvertown Tramway Act Amending Bill, 641.	
Cooma Church of England Lands Sale Bill, 641.	
Agreeing and disagreeing to amendments in Bankruptcy Bill, 174.	
Agreeing to amendments with amendments, in the Albury Cattle Sale Yards Bill, 197.	
Agreeing to, disagreeing to, amending and agreeing to, amendments in Government Railways Bill, 390.	
Agreeing to amendments made in the Victorian Coal-mining Company's Extension Bill, 410.	
Agreeing to amendment and not insisting upon disagreement to amendment in Government Railway Bill, 426.	
Agreeing to some, disagreeing to others, including an amendment in the Title, and amending others of the amendments in the Chinese Restriction and Regulation Bill, 531.	
Not insisting on disagreements from Council's amendments, nor upon Assembly's amendments, in the Chinese Restriction and Regulation Bill, 573.	
<b>FROM COUNCIL TO ASSEMBLY :—</b>	
Transmitting Perpetual Trustee Company Bill, 98.	
Australian Mutual Provident Society's Acts Amendment Bill, 326.	
Tattersall's Club, 346.	
Kent-street Roman Catholic Church Land Sale Bill, 152.	
Judges Enabling Bill, 185.	
Bulli Colliery Disaster Fund Bill, 398.	
Criminal Law Amendment Bill, 430.	
Church of England Property Bill, 455.	
St. Thomas Church, Enfield, Lands Sale Bill, 462.	
Permanent Trustee Company of New South Wales Bill, 462.	
Factories and Workshops Bill, 614.	
Returning Municipal Roads and Streets Bill, with amendments, 71.	
Albury Cattle Sale Yards Bill, with amendments, 113.	
Borough of Balmain Wharves Bill, with amendments, 151.	
Consolidated Revenue Fund Bill (No. 2.) without amendment, 308.	
Animals Infectious Diseases Bill, 338.	
Church and Perkins Streets (Newcastle) Bill, without amendment, 152.	
Supreme Court Appeals Act Amendment Bill, without amendment, 157.	
Bankruptcy Bill, with amendments, 158.	
Country Towns Water and Sewerage Act Extension Bill, without amendment, 177.	
Royalty on Oysters Abolition Bill, without amendment, 197.	
Yass Roman Catholic Church Land Sale Bill, without amendment, 210.	
Wentworth Electorate Subdivision Bill, with amendments, 210.	
Sydney Corporation Act Amendment Bill, with amendments, 229.	
Australasian Naval Force Bill, without amendment, 230.	
Inland Waters Fisheries Bill, with amendments, 247.	
Consolidated Revenue Fund Bill, without amendment, 247.	
Leichhardt Council Chambers (Mortgage) Bill, 258.	
Returning Rockdale Municipality Re-naming Bill, with amendments, 264.	
Metropolitan Water and Sewerage Act Amendment Bill, with amendments, 281.	
Conversion into Mining Conditional Purchases Validation Bill, with amendment, 281.	
Consolidated Revenue Fund Bill (No. 3), 349.	
Government Railways Bill, with amendments, 378.	
Redhead Coal-mine Railway Act Extension Bill, with amendments, 390.	
Distribution of Funds in Sempill's Estates Bill (No. 2), with amendments, 398.	
Consolidated Revenue Fund Bill (No. 4), without amendment, 416.	
Victorian Coal-Mining Company's Extension Bill, with amendments, 410.	
Christian Chapel Lands Sale Bill, without amendment, 426.	
Vine Diseases Act Amendment Bill, with amendments, 442.	
Public Works Bill, with amendments, 442.	
Consolidated Revenue Fund Bill (No. 5), without amendment, 486.	
Chinese Restriction and Regulation Bill, with amendments, 514.	
Kiama Tramway Act Amendment Bill, without amendment, 547.	
Contractors Debts Act Extension Bill, without amendment, 547.	
Consolidated Revenue Fund Bill (No. 6), without amendment, 554.	
Circular Quay Land Sale and Dedication Bill, with an amendment, 613.	
Bankruptcy Act Amendment Bill, with an amendment, 614.	
Church and Schools Lands Mining Bill, with an amendment, 615.	
Crown Lands Act Further Amendment Bill, without amendment, 626.	
Judgment Creditors Remedies Extension Bill, without amendment, 626.	
Government Railways Act Amendment Bill, without amendment, 593,	

REFERENCES TO THE VOTES AND PROCEEDINGS, VOL. I—13TH PARLIAMENT—SESSION, 1887-8.	PAPERS.	
M	VOL.	PAGE.
MESSAGES—(continued) :—		
FROM COUNCIL TO ASSEMBLY—(continued) :—		
Returning Silverton Tramway Act Amending Bill, with amendments, 593.		
Crown Lands Purchases Validation Bill, with an amendment, 594.		
Companies Bill, with an amendment, 594.		
Parramatta Church-street Amended Alignment, Bill, without amendment, 626.		
Municipal Loans Bill, without amendment, 626.		
North Shore, Manly, and Pittwater Tramway and Railway Bill, with amendments, 635.		
Divorce Extension Bill, with amendments, 638.		
Cooma Church of England Lands Sale Bill, with amendments, 639.		
Appropriation Bill, without amendment, 642.		
Repayment of Loans Bill, without amendment, 642.		
Public Works Loan Bill, without amendment, 642.		
Not insisting upon its amendments disagreed to in Bankruptcy Bill, 185.		
Agreeing to amendments upon amendments in Albury Cattle Sale-Yards Bill, 200.		
Agreeing to amendments in Kent-street Roman Catholic Church Land Sale Bill, 200.		
Not insisting on their amendment, but proposing one in lieu thereof, agreeing to amendment made by Assembly on their amendments and insisting on amendment and not insisting on amendment, in Government Railways Bill, 417.		
Agreeing to amendments made in the Perpetual Trustee Company Bill, 538.		
Insisting on some of its amendments, and does not insist on others, in the Chinese Restriction and Regulation Bill, 566.		
METROPOLITAN FIRE BRIGADES ACT OF 1884 :—		
Report of Fire Brigades Board for 1887, laid on Table, 378 .....	2	571
METROPOLITAN TRANSIT COMMISSIONERS :—		
Information respecting, laid on Table, 385 .....	2	291
METROPOLITAN WATER AND SEWERAGE ACT AMENDMENT BILL :—		
Motion made ( <i>Sir Henry Parkes</i> ) for Committee of the Whole, 196 ; House in Committee and resolution agreed to, 201 ; presented and read 1 <sup>o</sup> , 224 ; Message from Governor, 228 ; read 2 <sup>o</sup> , committed, reported with an amendment, and report adopted, 228 ; read 3 <sup>o</sup> , passed and sent to Council, 232 ; returned with amendments, 281 ; amendments agreed to, 308 ; assent reported, 317.	5	879
METZ (See "MINING").		
MIDNIGHT :—		
Sittings after, 4, 30, 53, 65, 77, 90, 99, 115, 119, 123, 136, 140, 146, 152, 162, 169, 186, 198, 210, 220, 242, 248, 264, 288, 296, 304, 329, 345, 361, 374, 381, 390, 422, 425, 430, 434, 442, 452, 452, 455, 469, 476, 480, 487, 494, 496, 501, 509, 514, 520, 526, 538, 544, 548, 554, 574, 580, 587, 603, 615, 619, 628, 639.		
MILITARY :—		
OFFICERS OF PERMANENT AND VOLUNTEER CORPS :—		
Return to Order ( <i>Second Session</i> 1887), laid on Table, 6 .....	2	13
ROAD, SOUTH HEAD TO BEN BUCKLER AND FORTS, BONDI :—		
Notification under Lands for Public Purposes Acquisition Act of resumption of land for, laid on Table, 22 .....	2	65
MAJOR PARROTT'S REPORT :—		
Motion made ( <i>Mr. Dibbs</i> ) that this House do now adjourn to consider answer to a question in reference to, and negative, 64.		
Correspondence respecting, on Coast and Harbour Defence, laid on Table, 84 .....	2	63
CASE OF DANIEL BEHAN :—		
Motion made ( <i>Mr. Alfred Allen</i> ) for a Select Committee to inquire into discharge of, late a Sergeant in the New South Wales Artillery, 71 ; name added to Committee, 89.		
DEFENCES OF NEW SOUTH WALES :—		
Report of Major-General Schaw on, laid on Table, 199 .....	2	47
CAPTAIN A. H. P. SAVAGE, PERMANENT ARTILLERY :—		
Motion made ( <i>Mr. Wall</i> ) for papers relative to appointment of, as Captain, 320 ; Return to Address laid on Table, 334 .....	2	11
ORDERLY CLERKS EMPLOYED IN THE BRIGADE OFFICE :—		
Return showing number for last twelve months, laid on Table, 334 .....	2	29
FORCES OF THE COLONY :—		
Annual Report for 1887 laid on Table, 425 .....	2	1
ENGAGEMENT OF IMPERIAL OFFICER :—		
Correspondence respecting, laid on Table, 479 .....	2	7
AMMUNITION :—		
Correspondence respecting Establishment of Manufactory, laid on Table, 479 .....	2	41
FREE RAILWAY PASSES :—		
Return respecting issued by the Staff Office of Volunteers, &c., during quarter ended 30 June, 1888, laid on Table, 524 .....	2	25
FRENCH POSTS IN THE NEW HEBRIDES :—		
Correspondence respecting evacuation of, laid on Table, 529 .....	8	1231
BRIGADE OFFICE ACCOUNTS :—		
Return respecting, laid on Table, 578 .....	2	25
MILLAUR, THOMAS (See "CROWN LANDS PURCHASES VALIDATION BILL").		
MILLGATE, GEORGE (See "CROWN LANDS").		
MILPARINKA (See "TELEGRAPHS").		
MINERALS (See "MINING").		
MINERS' RIGHTS (See "MINING").		
MINING (See also "CHURCH AND SCHOOLS LANDS MINING BILL") :—		
APPLICATIONS FOR MINERAL CONDITIONAL PURCHASES, PARISH OF METZ :—		
Further Return ( <i>in part</i> ) to an Order ( <i>Second Session</i> 1887), laid on Table, 6 ; Referred to Select Committee, on same subject, 463 .....	8	459
Motion made ( <i>Mr. Levien</i> ) for a Select Committee to inquire into and report upon the granting of to John Moore and others and the refusal and granting of other applications, 238 ; Returns to Order of 7th July and 21st September, respectively referred to Select Committee, 463 ; Report brought up, 572 .....	8	439
Motion made ( <i>Mr. J. P. Abbott</i> ) that the name of Mr. J. P. Abbott be removed from Select Committee, 462.		
Petition presented from John Moore and John McBean of Armidale, praying that they may be heard by counsel before the Committee, presented and read by the Clerk, 345 ; prayer of Petition granted, 348 .....	8	465
Petition presented from Joseph Francis M'Kinlay, of Armidale, praying to be heard before Select Committee, and prayer granted, 468 .....	8	467

REFERENCES TO THE VOTES AND PROCEEDINGS, VOL. I—13TH PARLIAMENT—SESSION, 1887-8.	PAPERS.	
	VOL.	PAGE.
<b>M</b>		
<b>MINING—(continued):—</b>		
<b>APPLICATIONS OF MESSRS. HAUGHTON AND PALMER TO MINE UNDER RESERVES AT KAHIBAH:—</b>		
Motion made ( <i>Mr. J. P. Abbott</i> ) for all, with all correspondence, surveys, plans, and reports, and any permits issued in respect of, and any application to convert such permit into a lease, 41; Return to Order laid on Table, 252 .....	8	369
<b>APPLICATIONS FOR MINERAL LEASES:—</b>		
Return to Order ( <i>Second Session, 1887</i> ), laid on Table, 223 .....	8	337
<b>APPLICATION OF MR. J. F. CONNOLLY TO MINE IN PARISH OF CURRAJONG:—</b>		
Motion made ( <i>Mr. Stokes</i> ) for all correspondence in reference to, between 1884 and 1887, 118; Return to Order laid on Table, 294 .....	8	349
<b>BULLI COLLIERY EXPLOSION:—</b>		
Copy of the Attorney-General's opinion respecting, laid on Table, 35 .....	8	435
Motion made ( <i>Mr. Melville</i> ) for all replies, letters, &c., by Mr. Mackenzie respecting Commission's Report, 185; Return to Order, laid on Table, 196 .....	8	437
Motion made ( <i>Mr. Melville</i> ) that this House do now adjourn to consider statements made by Examiner of Coal-fields in Papers laid on Table, and reflecting upon Commissioners Report on, and negatived, 200.		
<b>CHARGES AGAINST EXAMINER OF COAL-FIELDS:—</b>		
Report on, laid on Table, 273 .....	8	217
<b>CLAIM OF MATTHEW M'IVOR TO A TIN-MINE AT PHEASANT'S CREEK:—</b>		
Report of Select Committee of Session 1887 adopted, 273.		
<b>CLAIMS OF WILLIAM TOM, JUNIOR, AND J. H. A. LISTER AS FIRST DISCOVERERS OF GOLD IN THIS COLONY:—</b>		
Motion made ( <i>Mr. Dalton</i> ) for all petitions, letters, papers, &c., in connection with, 231.		
<b>DIAMOND DRILL, NO. A:—</b>		
Motion made ( <i>Mr. Hurley</i> ) for all correspondence and agreements respecting application for use of, dispatched to Clarence Siding, 232; Return to Order laid on Table, 252 .....	8	411
<b>DIAMOND DRILLS:—</b>		
Return showing outstanding accounts in connection with and Water Augers, laid on Table, 273 .....	8	433
<b>DUCKENFIELD COLLIERY:—</b>		
Correspondence relating to alleged Breaches of the Coal-fields Regulation Act at, laid on Table, 252.	8	343
<b>ENDOWMENT TO MUNICIPALITIES:—</b>		
Opinions of Attorneys-General in the years 1876 and 1888 on, laid on Table, 642 .....	2	273
<b>FATAL ACCIDENT TO JOHN MANSFIELD:—</b>		
Report and Evidence in connection with, at the Northumberland Colliery, laid on Table, 475 .....	8	249
<b>FATAL ACCIDENT TO EDWARD M'CARRAN:—</b>		
Report and Evidence in connection with, at the West Wallsend Colliery, laid on Table, 475 .....	8	259
<b>EXPLOSIVE GAS IN THE SOUTH WARATAH COLLIERY:—</b>		
Papers in connection with the influx of, laid on Table, 475 .....	8	253
<b>GOLD-MINING AND MINERAL LEASES:—</b>		
Motion made ( <i>Mr. Wall</i> ) for a return of, applied for during five years ending 1st September, 1887, showing the period that intervened between the date of application and the date of issue, 35; Return to Order laid on Table, 191 .....	8	473
<b>GOLD-MINING LEASES AT ARMIDALE:—</b>		
Return respecting, laid on Table, 642 .....	8	485
<b>JEREMIAH SHEA:—</b>		
Petition from, representing that he was sent to the Colony in 1818; that he is 88 years of age; that he discovered gold on the Northern Fields in 1852, but has received no acknowledgment for the same; that he is now, through infirmity, unable to earn his living, and praying relief, presented, 112 .....	8	1217
<b>LEASES IN THE BINGERA DISTRICT:—</b>		
Return to Order (Session 1885-86) laid on Table, 352 .....	8	409
<b>LANDS HELD BY MR. GARRETT, MINISTER FOR LANDS:—</b>		
Return respecting, laid on Table, 578 .....	8	263
<b>MESSRS. HUGH McNEILL AND PARTY—MINERAL LEASE AT CAPTAIN'S FLAT:—</b>		
Motion made ( <i>Mr. O'Sullivan</i> ) for Select Committee, 403; Report brought up, 592 .....	8	491
Petition presented ( <i>Mr. Dibbs</i> ) from Hugh McNeill and Party, praying to be heard by Counsel before the Select Committee, 491 .....	8	537
<b>MINERAL CONDITIONAL PURCHASE OF JAMES KENNEDY BROUGHM:—</b>		
Motion made ( <i>Mr. Chanter</i> ) for Papers, 601.		
<b>MINERAL LICENSE TAKEN UP BY MICHAEL CHARLES RENHAM, PARISH OF PICTON:—</b>		
Motion made ( <i>Mr. Chanter</i> ) for papers in reference to, 635.		
<b>MINING ACT FURTHER AMENDMENT ACT:—</b>		
Regulations relating to, laid on Table, 492 .....	8	539
<b>MINERS' RIGHTS:—</b>		
Petition presented ( <i>Mr. Sydney Smith</i> ) from miners of Hill End, Sofala, Sunny Corner, Rylstone, Cargo, Gulgong, Silverton, Limestone, Mount M'Donald, Bathurst, Wattle Flat, Nymagee, Hargraves, Copeland, Parkes, Mount Brown, Oberon, and Tambaroora, representing that the charge for a Miners' Right is excessive, and that the Miners' Right should remain in force for twelve months, and praying the House to consider the matter and grant relief, 380 .....	8	469
<b>MINES DEPARTMENT:—</b>		
Annual Report of the Stock Branch for 1886, laid on Table, 6; Do. 1887, laid on Table, 408 .....	8	543-573
Annual Report of Forest Branch for 1886, laid on Table, 97 .....	5	765
Annual Report for 1887, laid on Table, 378 .....	8	1
<b>PROSPECTING FOR GOLD AND OTHER MINERALS:—</b>		
Motion made ( <i>Mr. Sydney Smith</i> ) for Committee of the Whole for Address to Governor that £50,000 be placed on Estimates for 1888 for, 89; House in Committee and Resolution (£20,000), agreed to, 108.		
<b>SMELTING WORKS FOR TREATING BULK SAMPLES OF ORE:—</b>		
Motion made ( <i>Mr. Wall</i> ) for erection of, by Mines Department, and withdrawn, 354.		
<b>TERALBA COAL-MINING RESERVE:—</b>		
Adjournment of the House moved ( <i>Mr. McElhone</i> ) in reference to Mineral Conditional Purchases made by the Lane Family and Mr. Withers, 493.		
Motion made ( <i>Mr. McElhone</i> ) for papers in connection with selections of the Lane Family, T. Garrett, Greville, and others, 500; Returns to Order laid on Table, 547, 580; referred to Select Committee, 587; order for printing rescinded, 592.		

REFERENCES TO THE VOTES AND PROCEEDINGS, VOL. I—13TH PARLIAMENT—SESSION, 1887-8.	PAPERS.	
	VOL.	PAGE.
<b>M</b>		
<b>MINING—(continued):—</b>		
<b>TERALBA COAL-MINING RESERVE—(continued):—</b>		
Motion made ( <i>Mr. McElhone</i> ) for Select Committee to inquire into selections of Lane Family, Henry J. Withers, and William Thorne, 502; name of Sir Henry Parkes substituted for name of Mr. J. P. Abbott, 585; papers referred to Select Committee, 587.		
Plan of Reserves Nos. 83 and 60, showing Mineral Conditional Purchases and Mineral Leases held thereon, laid on Table (not printed), 547		
<b>THE MINING INDUSTRY:—</b>		
Motion made ( <i>Mr. Waddell</i> ) for encouragement to by the abolition of timber licenses for timber used as fuel for smelting, 608.		
<b>MINING ACT FURTHER AMENDMENT ACT (See "MINING").</b>		
<b>MINING CONDITIONAL PURCHASES (See "CONVERSION INTO MINING CONDITIONAL PURCHASES VALIDATION BILL").</b>		
<b>MINING BILL:—</b>		
Motion made ( <i>Mr. Abigail</i> ) for Committee of the Whole, 592; House in Committee, resolution agreed to, presented, and read 1 <sup>o</sup> , 602.		
<b>MINING ON PRIVATE PROPERTY:—</b>		
Petitions praying that a Bill be passed providing for, 257 (1 <sup>3</sup> ) .....	8	471
<b>MINISTER FOR LANDS (See "CROWN LANDS").</b>		
<b>MINISTERIAL ELECTION BILL:—</b>		
Motion made ( <i>Mr. O'Mara</i> ) for leave to bring in, presented and read 1 <sup>o</sup> , 36; Order of the Day postponed, 107, 147, 234, 252, 285, 321, 508.		
<b>MINISTERIAL STATEMENT:—</b>		
Made by Sir Henry Parkes, 123, 404.		
Made by Sir Henry Parkes—Resignation of Mr. Wise, the Attorney-General, 252.		
Made by Sir Henry Parkes—Resignation of Mr. Garrett, the Minister for Lands, 613.		
Made by Sir Henry Parkes—Acceptance of office as Attorney-General of Mr. G. B. Simpson, 264.		
Made by Mr. Burns—Revenue Receipts and Expenditure during the quarter ended 31 March, 1888, 361.		
Made by Sir Henry Parkes—Chinese Immigration, 364, 451.		
Made by Sir Henry Parkes—Public Business, Public Accounts, Estimates for Military Service, 501.		
Made by Sir Henry Parkes—Railway Policy, 501, 641.		
<b>MITCHELL, JOSEPH, ESQ., M.P.:—</b>		
Election of, as a Member for Newtown, reported, sworn, 303.		
Motion made ( <i>Mr. Copeland</i> ) to refer seat to Elections and Qualifications Committee, and negatived, 548.		
<b>MOAMA:—</b>		
Report upon Extension of Channel and Improvements to Wharf, 302 .....	3	1039
<b>MOLONG (See "RAILWAYS"; also "CROWN LANDS").</b>		
<b>MONETARY AND FINANCIAL (See "STATISTICS").</b>		
<b>MONTPELIER ESTATE:—</b>		
List of purchasers of leases of portions of, laid on Table (not printed), 8.		
<b>MOORE JOHN (See "MINING").</b>		
<b>MOREE (See "RAILWAYS").</b>		
<b>MORTGAGES OF STOCK (See "LIENS ON WOOL BILL").</b>		
<b>MOSS VALE (See "RAILWAYS").</b>		
<b>MOTIONS:—</b>		
Notice of, to take precedence, 328.		
Notices of General Business postponed in a bunch, 162, 203, 242, 248, 487, 628.		
General Orders to take precedence of, on Fridays, 593.		
Notice of postponed, 502.		
<b>MOULDER, EDWARD HENRY (See "CROWN LANDS").</b>		
<b>MOUNT BROWNE (See "TELEGRAPHS").</b>		
<b>MOUNT VICTORIA (See "RAILWAYS").</b>		
<b>MUDGE LINE (See "RAILWAYS").</b>		
<b>MULTIPLE CABLE:—</b>		
Information respecting, purchased, for Telephonic purposes, laid on Table, 267 .....	4	1185
<b>MULWALA (See "BRIDGES").</b>		
<b>MUNFORD'S CONDITIONAL PURCHASES AT MOLONG (See "CROWN LANDS").</b>		
<b>MUNICIPAL (See also "BY-LAWS"; also "DISTRICT GOVERNMENT BILL"; also "PARRAMATTA MUNICIPAL QUARRIES BILL"):—</b>		
<b>ASSOCIATIONS:—</b>		
Motion made ( <i>Mr. Hawken</i> ) that any measure to give effect to the principle of decentralization to confer power over local affairs should provide that the aggregation of districts, councils, shires, or municipalities into irresponsible associations shall be declared illegal, and by leave withdrawn, 29.		
<b>CORPORATION OF THE CITY OF SYDNEY:—</b>		
Statement of Receipts and Expenditure for 1885, 1886, and 1887, respectively, laid on Table, 429.	2	255
<b>FORBES MUNICIPALITY:—</b>		
Motion made ( <i>Mr. Stokes</i> ) for copies of all papers in connection with the special audit of accounts, 325; Return to Order laid on Table, 334 .....	2	279
<b>SPECIAL GRANTS TO MUNICIPALITIES:—</b>		
Motion made ( <i>Mr. Creer</i> ) for Committee of the Whole to consider an Address to the Governor for, 404; Order of the Day, discharged, 508.		
<b>LOCAL OPTION VOTE:—</b>		
Return showing result of, taken in Metropolitan and Suburban Municipalities in February, 1888, laid on Table, 524 .....	7	689
<b>MUNICIPALITIES OF FORBES AND PARKES:—</b>		
Return respecting Revenue derived from, laid on Table, 560 .....	2	287
<b>GRANTS FOR ROADS WITHIN MUNICIPAL BOUNDARIES:—</b>		
Return respecting, laid on Table, 635 .....	2	271
<b>ENDOWMENTS TO MUNICIPALITIES:—</b>		
Opinions of Attorneys General, in years 1876 and 1888, laid on Table, 642 .....	2	273
<b>MUNICIPAL LOANS BILL:—</b>		
Motion made ( <i>Mr. Day</i> ) for leave to bring in, 572; presented and read 1 <sup>o</sup> , 573; Order of the Day postponed, 585; read 2 <sup>o</sup> , committed, reported with amendments, and an amended Title, report adopted, 599; read 3 <sup>o</sup> , passed, and sent to Council, 602; returned without amendment, 626; Assent reported, 630.		

REFERENCES TO THE VOTES AND PROCEEDINGS, VOL. I—13TH PARLIAMENT—SESSION, 1887-8.		PAPERS.	
		VOL.	PAGE.
<b>M</b>			
<b>MUNICIPAL ROADS AND STREETS BILL:—</b>			
Motion made ( <i>Mr. Frank Farnell</i> ) for leave to bring in, presented and read 1 <sup>o</sup> , 22; read 2 <sup>o</sup> , committed, reported with amendments, and Report adopted. 42; read 3 <sup>o</sup> , passed, and sent to Council, 49; returned with amendments, 71; Order of the Day postponed, 77; amendments agreed to, and Message to Council, 192; Assent reported, 219.			
<b>MUNICIPALITIES ACT OF 1867 AMENDMENT BILL:—</b>			
Motion made ( <i>Mr. Davis</i> ) for leave to bring in, presented and read 1 <sup>o</sup> , 48; Order of the Day postponed, 65; Order of the Day discharged and Bill withdrawn, 145.			
<b>MUNICIPALITIES ACT OF 1867 AMENDMENT BILL (No. 2):—</b>			
Motion made ( <i>Mr. Davis</i> ) for Committee of the Whole, 168; House in Committee and resolution agreed to, 193; presented and read 1 <sup>o</sup> , 197; Order of the Day postponed, 325, 365; read 2 <sup>o</sup> , committed, 476.			
<b>MURPHY, MARY ELIZABETH and WILLIAM EDWARD (See "CROWN LANDS PURCHASES VALIDATION BILL").</b>			
<b>MURRAY RIVER (See "BRIDGES").</b>			
<b>MURRAY, THE UPPER (See "BRIDGES").</b>			
<b>MURRUMBURRAH PLATFORM:—</b>			
Motion made ( <i>Mr. Gordon</i> ) for return of goods and passenger traffic and revenue and expenditure at, 295; Return to Order laid on Table, 338.....			
		6	730
<b>MUSIC HALLS (See "PLACES OF PUBLIC AMUSEMENT OR RESORT").</b>			
<b>MUSWELLBROOK (See "COMMONS," also "RAILWAYS").</b>			
<b>N</b>			
<b>NAMOI ELECTORATE:—</b>			
<b>REVENUE DERIVED FROM:—</b>			
Motion made ( <i>Mr. Dangar</i> ) for a return showing total, from Crown Lands, mining leases and licenses, miners' rights, and timber licenses, 41.			
<b>NARRABRI (See "RAILWAYS").</b>			
<b>NASH v. COPELAND (See "RAILWAYS").</b>			
<b>NATIONAL AND LOCAL WORKS:—</b>			
Statement of expenditure on, in the Colony, from 1860 to 1886, laid on Table, 28.....			
		8	1231
<b>NATIONAL PARK:—</b>			
Particulars respecting William Ross late overseer at, laid on Table, 52 .....			
		5	817
<b>NATURALIZATION, LETTERS OF (See "CHINESE").</b>			
<b>NAUTICAL SCHOOL SHIP "VERNON":—</b>			
Report for 1887, laid on Table, 285.....			
		4	683
<b>NAVAL FORCE (See "AUSTRALASIAN NAVAL FORCE BILL," also "OFFICERS, IMPERIAL").</b>			
<b>NEILD, MR. J. C., M.P.:—</b>			
Motion made ( <i>Mr. Hassall</i> ) for a return showing the amount paid by the Treasurer to, since his appointment as Executive Commissioner for the South Australian Exhibition, 30; Return to Order, laid on Table, 75.....			
		8	1013
<b>NEUTRAL BAY (See "RECLAMATION OF NEUTRAL BAY AND CAREENING COVE").</b>			
<b>NEWCASTLE (See "CHURCH AND PERKINS STREETS NEWCASTLE BILL"; also "HUNTER STREET NEWCASTLE EXTENSION BILL"; also "PARLIAMENTARY STANDING COMMITTEE ON PUBLIC WORKS").</b>			
<b>NEWCASTLE SAND-DRIFT RECLAMATION ACT REPEAL BILL:—</b>			
Motion made ( <i>Mr. Abigail</i> ) for leave to bring in, 112; presented and read 1 <sup>o</sup> , 112; Order of the Day postponed, 296, 309.			
<b>NEW HEBRIDES:—</b>			
Correspondence respecting evacuation of the French military posts in, laid on Table, 529.....			
		8	1,239
<b>NEWSPAPER POSTAGE:—</b>			
Motion made ( <i>Mr. McElhone</i> ) for imposition of, amendment proposed, and negatived, 303; Original Question negatived, 304.			
<b>NEWTOWN (See "ELECTORAL").</b>			
<b>NEW TRIALS LIMITATION BILL:—</b>			
Motion made ( <i>Mr. Hassall</i> ) for leave to bring in, presented, and read 1 <sup>o</sup> , 122; Order of the Day, postponed, 215, 285, 508; discharged and Bill withdrawn, 608.			
<b>NOBBS, JOHN, ESQ., M.P.:—</b>			
Election of, as a Member for Central Cumberland, reported, 339; sworn, 342.			
<b>NO QUORUM:—</b>			
In House before commencement of business, 297.			
In House after commencement of business, 108, 321, 599.			
Reported from Committee of Ways and Means, 234.			
Attendances of Members in Divisions and Counts-out.....			
		1	653
<b>NORTH HEAD:—</b>			
<b>QUARANTINE STATION:—</b>			
Motion made ( <i>Mr. Lyne</i> ) for all papers, letters, &c., in reference to removal of, 241; Return to Order laid on Table, 263 .....			
		2	241
Motion made ( <i>Mr. See</i> ) for correspondence, &c., in reference to removal of, 573.			
<b>NORTH SHORE (See "WHALING ROAD," also "PARLIAMENTARY STANDING COMMITTEE ON PUBLIC WORKS").</b>			
<b>NORTH SHORE BOROUGH'S WHARVES BILL:—</b>			
Petition presented ( <i>Mr. Trickett</i> ) for leave to proceed with, under 65th Standing Order, presented, read 1 <sup>o</sup> , and referred to Select Committee, 23; motion made that Minutes of Proceedings and Evidence of previous Session be laid on Table and referred to Select Committee, documents laid on Table and referred, 115; Report brought up, 463.....			
		2	971
<b>PETITIONS PRESENTED FROM:—</b>			
Property-owners and residents of St. Leonards, in favour of, 16.....			
		2	1,005
The Captain and Secretary of the North Shore Rowing Club, to be heard by counsel or in person before the House or Select Committee in opposition, and referred to Select Committee on Bill, 40 .....			
		2	1,009
P. O. Williams, A.G. Milson and others, with similar prayer, and referred to Select Committee on Bill, 40.....			
		2	1,007



REFERENCES TO THE VOTES AND PROCEEDINGS, VOL. I—13TH PARLIAMENT—SESSION, 1887-8.	PAPERS.	
	VOL.	PAGE.
<b>N</b>		
<b>NORTH SHORE, MANLY, AND PITTWATER TRAMWAY AND RAILWAY BILL:—</b>		
Petition presented ( <i>Mr. Reid</i> ) for leave to bring in, 48; leave given, presented and read 1 <sup>o</sup> , 60; referred to Select Committee, 64; Report brought up, 89; read 2 <sup>o</sup> , and committed, 146; further considered in Committee, reported with amendments and report adopted, 233; read 3 <sup>o</sup> , passed and sent to Council, 236; returned with amendments, 635; Order of the Day postponed, 641.	2	1,011
<b>PETITIONS IN FAVOUR OF, PRESENTED:—</b>		
From Residents at St. Leonards and North Shore, and that provision be made to make the proposed bridge at the Spit, free of Toll, 145 .....	2	1,027
From Residents at Manly with similar prayer, 145 .....	2	1,027
<b>NORTHUMBERLAND COLLIERY (See "MINING").</b>		
<b>NO TELLERS:—</b>		
In Division, 59, 140.		
<b>NOTICES OF MOTIONS:—</b>		
Of General Business postponed in a bunch, 162, 208, 242, 248, 487, 628 Postponed, 502.		
For motion to take precedence, 328.		
<b>NOTIFICATIONS (See "LANDS FOR PUBLIC PURPOSES ACQUISITION ACT").</b>		
<b>NOWLAND, MR. (See "RAILWAYS").</b>		
<b>NOXIOUS TRADES:—</b>		
Motion made ( <i>Mr. Carruthers</i> ) that legislation dealing with, in and around Sydney, is urgently required, and withdrawn, 232.		
<b>NOXIOUS WEEDS IN THE DISTRICT OF THE RICHMOND RIVER:—</b>		
Motion made ( <i>Mr. Ewing</i> ) for report and papers in connection with, 546; Return to Order laid on Table, 578 .....	8	983
<b>NUISANCE ON NORTH SHORES OF BOTANY BAY (See "BOTANY BAY").</b>		
<b>NUISANCES PREVENTION ACT (See "BY-LAWS").</b>		
<b>O</b>		
<b>OAKY PARK COAL-MINING COMPANY'S RAILWAY BILL:—</b>		
Petition presented ( <i>Mr. Hurley</i> ) for leave to bring in, 252; leave given 258; presented and read 1 <sup>o</sup> , 263; referred to Select Committee, 268; Report brought up, 353; motion made for second reading, and amendment moved to refer back to Select Committee, and passed, 487; Report (Second) brought up, 519; Order of the Day postponed, 628 .....	2	1,029
Petition presented from Brisbane Doyle, of Parramatta, stating that the Bill would seriously affect his rights, and praying the House to refer the Bill back to the Select Committee, 389; referred to Select Committee, 487 .....	2	1,037
Petition presented from Sarah Doyle, praying that the Bill may be again referred back to the Select Committee, and that she may be heard before the Committee, 608 .....	2	1,045
<b>OATHS (See "CLERK OF ASSEMBLY").</b>	2	1,047
<b>OFFICERS, IMPERIAL:—</b>		
Despatch relative to the employment of officers of Navy under Colonial Governments, laid on Table, 475. ....	2	23
Correspondence respecting engagement of military, laid on Table, 479. ....	2	7
<b>OLIVER, MR., LATE INSPECTOR OF FISHERIES (See "FISHERIES").</b>		
<b>O'MARA, MR.:—</b>		
<b>A MEMBER FOR MONARO:—</b>		
Declared guilty of persistent disorder, and removed, by Sergeant-at-Arms, from the Chamber, 220.		
<b>OPENING OF THE SESSION:—</b>		
Proclamation read by Clerk, 1.		
Governor's Opening Speech, 2.		
<b>OPHTHALMIC PATIENTS (See "ASYLUMS").</b>		
<b>ORANGE TO MOLONG (See "RAILWAYS").</b>		
<b>ORDER (See "POINTS OF ORDER").</b>		
<b>ORDERLY CLERKS:—</b>		
Return showing number of, employed in Brigade Office, during last twelve months, laid on Table, 334 .....	2	29
<b>ORDERS FOR PAPERS:—</b>		
Motion made ( <i>Mr. O'Sullivan</i> ) for a return showing what Resolutions for the production of departmental papers, returns, correspondence, &c., have not been attended to, 118; Returns ( <i>in part</i> ) to Order, laid on Table, 191, 223, 257 .....	1	839, 841, 843
Motion made ( <i>Mr. Wall</i> ) for a return showing number made since 1 January, 1886, which have not been complied with, 210; Returns ( <i>in part</i> ) to Order, laid on Table, 257, 334 .....	1	845, 847
<b>ORDERS OF THE DAY:—</b>		
Discharged, 77, 107, 137, 145, 146, 185, 192, 233, 241, 246, 252 (?), 309, 325, 506 (?), 507, 508 (?), 608 (?).		
Of General Business postponed in a bunch, 248, 430, 487.		
Of Government Business postponed in a bunch, 417, 430, 463, 468, 487, 502, 509, 628.		
Postponed after debate, 487.		
Motion Rescinding postponement of, to day other than a sitting day, 585.		
General Business to take precedence of Motions on Fridays, 593.		
<b>ORDNANCE LANDS TRANSFER BILL:—</b>		
Presented and read 1 <sup>o</sup> , <i>pro forma</i> , 2.		
<b>ORIGINAL GRANTS OF LAND BOUNDARIES BILL:—</b>		
Motion made ( <i>Mr. J. S. Farnell</i> ) for leave to bring in, presented and read 1 <sup>o</sup> , 40; Order of the Day postponed, 77, 107, 145, 169, 192, 224; read 2 <sup>o</sup> , and committed, 253; Order of the Day postponed, 285, 321, 341, 386, 433, 493.		
<b>O'ROURKE AND McSHARRY (See "RAILWAYS").</b>		
<b>O'SULLIVAN, MR.:—</b>		
<b>MEMBER FOR QUEANBEYAN:—</b>		
Declared guilty of persistent disorder, and removed, by Sergeant-at-Arms, from the Chamber, 221.		
<b>OVERTIME TO OFFICERS (See "CROWN LANDS").</b>		
<b>OYSTERS (See "ROYALTY ON OYSTERS ABOLITION BILL").</b>		

REFERENCES TO THE VOTES AND PROCEEDINGS, VOL. I—13TH PARLIAMENT—SESSION, 1887-8.		PAPERS.	
		VOL.	PAGE.
<b>P</b>			
PADDINGTON (See "ELECTORAL").			
PARAGUAY, REPUBLIC OF (See "DESPATCHES").			
PARISH ROADS (See "ROADS").			
PARKES (See "RAILWAYS"; also "MUNICIPAL"; also "PUBLIC BUILDINGS"; also "CROWN LANDS").			
PARKES, THE HONORABLE SIR HENRY, G.C.M.G., M.P. :—			
Motion made ( <i>Mr. McElhone</i> ) that House do now adjourn, to call attention to replies given in reference to paragraphs in certain newspapers, commenting on a compromise alleged to have been made by, with his creditors, some of whom, it is alleged, are his colleagues in the present Government,—and negatived, 70.			
Resignation of, as a Member for St. Leonards, reported, and seat declared vacant, 73; issue and return of writ reported, sworn, 87.			
List of purchasers of leases of portions of the Montpelier Estate, laid on Table (not printed), 85.			
Ministerial Statement made by, 123, 252, 264, 364, 404, 451, 501 (?), 613, 641.			
PRIVILEGE :—			
Motion made ( <i>Mr. Garvan</i> ) that Sir Henry Parkes, Colonial Secretary and Premier, having tendered his resignation as a Member, and said resignation having been accepted, this House declines to transact any further business till the Premier occupies his Seat as an elected Member of this House, and negatived, 76.			
Name substituted for Mr. J. P. Abbott on Select Committee, "Teralba Coal-mining Reserve," 585			
PARKES, VARNEY, Esq., M.P. :—			
Resignation of, as Member for Central Cumberland, reported, and seat declared vacant, 311.			
PARKS :—			
PUBLIC :—			
Notification under the Lands for Public Purposes Acquisition Act of the resumption of land for, Albury, laid on Table, 6.....			
		5	827
Returns showing subsidies, granted for improvement of, for the year 1887, laid on Table, 35.....			
		5	805
Return showing subsidies from the year 1880 to 1887 inclusive, laid on Table, 524.....			
		5	807
NATIONAL :—			
Particulars respecting William Ross, late overseer at, laid on Table, 52.....			
		5	817
CENTENNIAL :—			
Motion made ( <i>Mr. O'Sullivan</i> ) for all papers, &c., in connection with scheme of, 208.			
Motion made ( <i>Mr. Dibbs</i> ) for papers relating to construction and dedication, 308.			
RESERVE AT KURNELL, BOTANY BAY :—			
Motion made ( <i>Mr. Carruthers</i> ) that immediate steps be taken to secure, adjacent to the place where Captain Cook first landed in Australia, and withdrawn, 232.			
PARLIAMENT (See also "HANSARD"; also "PRIVILEGE") :—			
Opening of the Session, 1.			
Prorogued, 642.			
FRANKING MEMBERS CORRESPONDENCE ON PUBLIC BUSINESS :—			
Motion made ( <i>Mr. Ewing</i> ) that all letters on public business incidental upon the representation in Parliament of an Electorate shall be carried free by post, 24; and negatived, 25.			
THE LEGISLATIVE COUNCIL :—			
Motion made ( <i>Mr. Walker</i> ) that one Chamber is all that is necessary for the transaction of the Parliamentary Business—that the Legislative Council is useless and dangerous, and ought to be abolished, and withdrawn, 36.			
PAYMENT OF MEMBERS OF THE LEGISLATIVE ASSEMBLY :—			
Motion made ( <i>Mr. Fletcher</i> ) for Committee of the Whole, to consider the necessary steps to be taken to make provision for, 28; House in Committee, and resolution agreed to, 42.			
SALE OF INTOXICATING DRINK IN THE BUILDINGS :—			
Motion made ( <i>Mr. Thompson</i> ) that the practice of selling and supplying intoxicating drink within the walls of the building should be at once discontinued, and negatived, 59.			
HOUSES OF—STATE HOUSE :—			
Motion made ( <i>Mr. Dibbs</i> ) for Committee of the Whole to consider expediency of bringing in a Bill to appropriate £150,000 from sale of portion of Centennial Park for erecting a State House, to be used as Houses of Parliament, in Macquarie-street, 60; Order of the Day, postponed, 103, 192(?), 252, 508; discharged, 586.			
NEW HOUSES OF :—			
Motion made ( <i>Mr. R. Burdett Smith</i> ) that no further delay take place in the erection of, and by leave withdrawn, 169.			
LIGHTING BUILDINGS WITH ELECTRIC LIGHT :—			
Motion made ( <i>Mr. Thompson</i> ) for all recommendations, tenders, correspondence, &c., in connection with, 103;			
PORTRAIT OF WILLIAM CHARLES WENTWORTH :—			
Letter reported from Executive Commissioner of the Centennial Exhibition, Melbourne, asking for loan of pictures, and resolution passed against sending them, 569.			
PARLIAMENTARY REPRESENTATIVES ALLOWANCE BILL :—			
Motion made ( <i>Mr. Garrett</i> ) for Committee of the Whole, 208; House in Committee, 258; Resolution reported and agreed to, 259; Message from the Governor, 268; read 1 <sup>o</sup> , 268; read 2 <sup>o</sup> , committed, reported, and report adopted, 520; read 3 <sup>o</sup> passed 548; sent to Council, 549.			
		1	885
PARLIAMENTARY STANDING COMMITTEE ON PUBLIC WORKS :—			
Motion made ( <i>Mr. Sutherland</i> ) for appointment of, as provided for by the Public Works Act of 1888, Committee appointed by Ballot, 508.			
PUBLIC WORKS REFERRED TO :—			
Wharfage accommodation, Woolloomooloo Bay, 640.			
Improvements to the Circular Quay, 640.			
Storage Reservoir at Potts Hill, 640.			
Dredge and plant for Sydney Harbour, 640.			
Second pipe between Potts Hill and Crown-street, 640.			
Improvements to the entrance of the Richmond River, 640.			
Bridge at the Spit, Middle Harbour, 640.			
New Central Police Court, 640.			
Improvements to the entrance of the Clarence River, 641			
Drainage works, Manly, 641.			
Drainage works, North Shore, 641.			
Drainage works for the Western Suburbs, 641.			
Harbour improvements at Newcastle, 641.			

REFERENCES TO THE VOTES AND PROCEEDINGS, VOL. I—13TH PARLIAMENT—SESSION, 1887-8.		PAPERS.	
		VOL.	PAGE.
<b>P</b>			
PARNELL, MESSRS. AND MISSES (See "CROWN LANDS").			
PARRAMATTA (See also "BRIDGES") :—			
INDUSTRIAL SCHOOL FOR GIRLS :—			
Amended Regulations under the Industrial Schools Act of 1866, laid on Table, 155 .....		4	521
GAOL :—			
Notification of resumption, under Lands for Public Purposes Acquisition Act, of land in parish of Field of Mars, required for extension of, laid on Table, 231 .....		4	1227
POLICE MAGISTRATE FOR :—			
Return to Order (Session 1885), laid on Table, 425 .....		2	627
Motion made ( <i>Mr. Frank Farnell</i> ) for Address for papers in connection with appointment of, 429; Returns to Addresses laid on Table, 451 (not printed), 635 .....		2	629
PARRAMATTA CHURCH-STREET AMENDED ALIGNMENT BILL :—			
Petition presented ( <i>Mr. Hugh Taylor</i> ) for leave to bring in, 302; leave given, presented, and read 1 <sup>o</sup> , 308; referred to Select Committee, 314; Report brought up, 348; Order of the Day postponed, 416, 508, 513, 543, 579, 585; read 2 <sup>o</sup> , committed, reported without amendment, report adopted, 599; read 3 <sup>o</sup> , passed, and sent to Council, 602; returned without amendment, 626; Assent reported, 629.		2	1049
PARRAMATTA MUNICIPAL QUARRIES BILL :—			
Petition presented ( <i>Mr. Hugh Taylor</i> ) for leave to bring in, 302; leave given, presented, and read 1 <sup>o</sup> , 308; referred to Select Committee, 314; Report brought up, 348; Order of the Day postponed, 416, 508, 513, 543, 579, 585; read 2 <sup>o</sup> , committed, reported without amendment, report adopted, 599; read 3 <sup>o</sup> , passed, and sent to Council, 601.		2	1055
PARROTT, MAJOR (See "MILITARY").			
PARRY'S CONDITIONAL PURCHASES (See CROWN LANDS").			
PARTNERSHIP BILL :—			
Motion made ( <i>Mr. J. P. Abbott</i> ) for Committee of the Whole, 64; Order of the Day postponed, 103, 147, 389; Order of the Day discharged, 507.			
PASSENGER TRAFFIC (See "RAILWAYS").			
PASTORAL LEASES :—			
Return giving particulars of appeals in connection with rents of, not yet dealt with by Minister, laid on Table, 403 .....		5	191
PASTURES AND STOCK PROTECTION ACT AMENDMENT BILL :—			
Motion made ( <i>Mr. Garrett</i> ) for Committee of the Whole, 243; Order of the Day for Committee discharged, 309.			
PASTURES AND STOCK PROTECTION BOARDS :—			
Motion made ( <i>Mr. J. P. Abbott</i> ) for copies of balance-sheets, 349; Return ( <i>in part</i> ) to Order laid on Table, 619; Further Return to Order laid on Table, 635 .....		8	599, 635
PATENT FEES (See "ATTORNEY-GENERAL").			
PATENTS (See "INVENTIONS") :—			
OFFICE :—			
Regulations under Patents Act laid on Table, 257, 378 .....		8	1241, 1245
PATENTS LAW AMENDMENT ACT AMENDMENT BILL :—			
Motion made ( <i>Mr. Haynes</i> ) for leave to bring in, 585.			
PATERSON RIVER :—			
CONTRACT FOR BRIDGE OVER :—			
Motion made ( <i>Mr. Hurley</i> ) for Select Committee, 404.			
PATHOLOGIST (See "PRINCE ALFRED HOSPITAL").			
PATIENTS RECEIVED INTO HOSPITALS (See "HOSPITALS").			
PAYMENT OF MEMBERS OF THE LEGISLATIVE ASSEMBLY (See also "PARLIAMENTARY REPRESENTATIVES ALLOWANCE BILL").			
Motion made ( <i>Mr. Fletcher</i> ) for Committee of the Whole, to consider the necessary steps to be taken to make provision for, 28; House in Committee, and resolution agreed to, 42;			
PEARCE'S CORNER (See "RAILWAYS").			
PEAT'S FERRY ACCIDENT (See "RAILWAYS").			
PENAL ADMINISTRATION :—			
Report respecting the proposed changes in, laid on Table, 52 .....		4	1213
PENRITH (See "RAILWAYS" also "BRIDGES").			
PERMANENT ARTILLERY (See "MILITARY").			
PERMANENT TRUSTEE COMPANY OF NEW SOUTH WALES BILL :—			
Received from Legislative Council, and on motion ( <i>Sir Henry Parkes</i> ), read 1 <sup>o</sup> 469; read 2 <sup>o</sup> committed, reported without amendment, report adopted 508; read 3 <sup>o</sup> , passed, and returned to Council, 524; Assent reported, 539.			
PERPETUAL TRUSTEE COMPANY BILL :—			
Petition presented ( <i>Mr. Trickett</i> ) for leave to proceed with, under the 65th Standing Order, 35; received from Legislative Council, read 1 <sup>o</sup> and 2 <sup>o</sup> , 98; Order of the Day postponed, 107, 147, 234, 252, 288; committed, reported with amendments, and report adopted, 342; Order of the Day postponed, 353, 479; read 3 <sup>o</sup> passed and returned to Council with amendments, 505; amendments agreed to 538; Assent reported, 555.			
PERRY'S COMBINATION TRUCK (See "RAILWAYS").			
PEST (See "RABBIT PEST").			
PETERSHAM (See "RAILWAYS").			
PETITIONS (See also "INSOLVENCY") :—			
Sessional Order as to printing of, passed, 12.			
Read by Clerk, 76, 84, 88, 127, 145, 218, 246, 252, 294, 303, 345, 352, 421, 437, 454, 492, 496, 505, 519, 543, 565, 579, 635.			
Referred to Select Committee, 40(?) , 122, 135, 165, 192, 215, 232, 324, 328, 403, 491.			
To be heard in person or by Counsel before Select Committee, 144, 150, 161, 181, 192, 208, 341, 294.			
Weekly Abstract of, Nos. 1 to 37 .....		1	745
PHARMACEUTICAL SOCIETY OF NEW SOUTH WALES INCORPORATION BILL :—			
Petition presented ( <i>Mr. Sydney Smith</i> ) for leave to bring in, 16; leave given, 23; presented and read 1 <sup>o</sup> , 25; referred to Select Committee, 28; Report brought up, 76; motion made for 2 <sup>o</sup> , and debate adjourned, 145; motion for 2 <sup>o</sup> negatived, 233.		2	1061
PHEASANT'S CREEK TIN-MINE See ("MINING").			
PITT, MR. GEORGE MATCHAM, JUNIOR (See "CROWN LANDS").			
PITTWATER TRAMWAY AND RAILWAY (See "NORTH SHORE, MANLY, AND PITTWATER TRAMWAY AND RAILWAY BILL").			

REFERENCES TO THE VOTES AND PROCEEDINGS, VOL. I—13TH PARLIAMENT—SESSION, 1887-8.	PAPERS.
	VOL. PAGE.
<b>P</b>	
<b>PLACES OF PUBLIC AMUSEMENT OR RESORT :—</b>	
Report on Theatres and, laid on Table, 128 .....	8 1209
Motion made ( <i>Mr. Dowel</i> ) that the Government should bring in a Bill to place under proper control; to provide improved construction, so as to insure greater immunity from risk from fire or panic, 129.	
<b>POINTS OF ORDER (See also "SPEAKER") :—</b>	
Arising in the House, 24, 42, 156, 192, 224, 252, 259, 315, 426, 433, 455, 574, 579, 587, 599, 635. Reported from Committee of Supply, 433 <sup>(2)</sup> , 452.	
<b>POLICE (See also "ELECTORAL") :—</b>	
Correspondence respecting duties of, laid on Table, 82 .....	4 1211
Report of Department for 1887, laid on Table, 257 .....	4 1203
<b>WILLIAM STAFFORD, EX-SERGEANT :—</b>	
Motion made ( <i>Mr. O'Sullivan</i> ) for Papers respecting dismissal of, 338; Return to Order, laid on Table, 352 .....	4 1215
Petition presented ( <i>Dr. Ross</i> ), from William Stafford, in reference to dismissal of, 425 .....	4 1221
<b>POLICE MAGISTRATE (See "ADMINISTRATION OF JUSTICE").</b>	
<b>POLICY OF THE GOVERNMENT (See "VOTE OF CENSURE").</b>	
<b>POLL-TAX (See "CHINESE").</b>	
<b>POOLE, MR. AND MRS. (See "CROWN LANDS").</b>	
<b>POOR OF SYDNEY, RELIEF TO (See "CENTENARY OF THE COLONY"; also "SICK POOR OF THE METROPOLIS").</b>	
<b>POPULATION (See also "STATISTICS") :—</b>	
Return showing estimated on 31 December, 1887, of New South Wales and Victoria respectively, laid on Table, 352 .....	7 1393
<b>POSTAL :—</b>	
Thirty-second Annual Report of the Postmaster-General, being for 1886, laid on Table, 6 .....	4 783
Thirty-third Annual Report of the Postmaster-General, being for 1887, laid on Table, 635 .....	4 881
<b>FRANKING MEMBERS' CORRESPONDENCE ON PUBLIC BUSINESS :—</b>	
Motion made ( <i>Mr. Ewing</i> ) that all letters on public business incidental upon the representation in Parliament of an Electorate shall be carried free by post, 24, and negatived, 25.	
<b>LETTER-SORTERS AND LETTER-CARRIERS :—</b>	
Motion made ( <i>Mr. Frank Smith</i> ) for a return showing the number of sorters appointed in General Post Office during two years, with names, dates of appointment, and salaries, also number of carriers who have received promotion during same period, 77; Return to Order laid on Table, 128 .....	4 981
<b>FUTURE MAIL SERVICE BETWEEN GREAT BRITAIN AND AUSTRALIA, VIA SUEZ :—</b>	
Further Correspondence respecting, laid on Table, 252, 341 .....	4 1037-1081
Motion made ( <i>Mr. Roberts</i> ) for Committee of the Whole to consider resolutions, 356; Message from Governor recommending, 355; Order of the Day postponed, 361; House in Committee, Resolutions reported, 365; agreed to, 366.	4 1109
<b>CONFERENCE :—</b>	
Proceedings of, held in Sydney in January, 1883, laid on Table, 252 .....	4 883
<b>POSTAGE ON NEWSPAPERS :—</b>	
Motion made ( <i>Mr. McElhone</i> ) for imposition of, amendment moved and negatived, 303; Original Question negatived, 304.	
<b>CORRESPONDENCE, RECORD, AND MAIL BRANCHES, GENERAL POST OFFICE :—</b>	
Return showing names and length of service of Clerks employed in, laid on Table, 324 .....	4 979
<b>TRANSIT CHARGES ON MAILS THROUGH FRANCE AND ITALY :—</b>	
Correspondence respecting, laid on Table, 341 .....	4 1111
<b>FORMATION OF STREET NORTH OF THE GENERAL POST OFFICE :—</b>	
Motion made ( <i>Mr. Dibbs</i> ) for plan showing the proposed new street, with Mr. Dibbs' proposed amendment, 454; Return to Order laid on Table ( <i>as an Exhibit only</i> ), 602 .....	4 1125
Correspondence and papers laid on Table, 484 .....	4 1141
Message from Governor, 383; Motion made ( <i>Mr. Roberts</i> ) for Committee of the Whole to consider Resolutions, 390; Order of the Day postponed, 410; House in Committee, 416, 479, 484, 487.	
<b>CORRESPONDENCE RE-DIRECTED FOR MEMBERS :—</b>	
Motion made ( <i>Mr. Chanter</i> ) for no further charge to be made on, and the motion not having been put at 7 o'clock, Government Business took precedence, 433.	
<b>POSTPONEMENTS RESCINDED :—</b>	
Motion made ( <i>Mr. J. P. Abbott</i> ) in reference to business fixed for other than a sitting day, 585.	
<b>POTTS' HILL (See "WATER SUPPLY") (See also "PARLIAMENTARY STANDING COMMITTEE ON PUBLIC WORKS").</b>	
<b>PRACTICE OF MEDICINE AND SURGERY (See "MEDICINE AND SURGERY").</b>	
<b>PRECEDENCE OF BUSINESS (See "BUSINESS OF THE HOUSE").</b>	
<b>PREFERENTIAL CLAIMS FOR RENT BILL :—</b>	
Motion made ( <i>Mr. Wall</i> ) for leave to bring in, 76.	
<b>PRE-LEASE (See "CROWN LANDS").</b>	
<b>PREMISES RENTED BY THE GOVERNMENT :—</b>	
Further Return to Order ( <i>Second Session, 1887</i> ), laid on Table, 191 .....	8 1249
<b>PRESBYTERIAN CEMETERY AT MACLEAN :—</b>	
Motion made ( <i>Mr. McFarlane</i> ) for a Select Committee to inquire into claims of Messrs. J. Macdonald, F. Mackenzie, and D. Shearer, to be reinstated as Trustees, 71; Petition presented on 11th May, 1887, referred, 122.	
Petition from Moderator of the General Assembly, for leave to be represented before the Select Committee, presented, 128 .....	8 1255
<b>PRESERVATION OF FISH (See "INLAND WATERS FISHERIES BILL").</b>	
<b>PREVIOUS QUESTION :—</b>	
Moved and negatived, 165.	
<b>PRINCE ALFRED HOSPITAL :—</b>	
Motion made ( <i>Mr. Hassall</i> ) for all correspondence between the University and W. C. Wilkinson, Esq., M.P., relative to appointment of Pathologist or Physician to, 231; Return to Order laid on Table, 257 .....	4 775
<b>PRINTING OFFICE (See "GOVERNMENT").</b>	
<b>PRISONS (See "ADMINISTRATION OF JUSTICE").</b>	
<b>PRIVATE BARS IN PUBLIC HOUSES :—</b>	
Motion made ( <i>Mr. Henson</i> ) that the system of, is an evil the Government should at once take steps to suppress; Previous Question moved and negatived, 165.	
<b>PRIVATE BILLS :—</b>	
Vote of Chairman of Select Committee on, Sessional Order passed, 11.	
Motion made ( <i>Mr. Barbour</i> ) for Committee of the Whole to consider the question of remuneration to Members attending on Select Committees, 608.	

REFERENCES TO THE VOTES AND PROCEEDINGS, VOL. I—13TH PARLIAMENT—SESSION, 1887-8.	PAPERS.	
	VOL.	PAGE.
<b>P</b>		
<b>PRIVILEGE :—</b>		
Motion made ( <i>Mr. Garvan</i> ) that Sir Henry Parkes, Colonial Secretary and Premier, having tendered his resignation as a Member, and said resignation having been accepted, this House declines to transact any further business till the Premier occupies his Seat as an elected Member of this House, and negatived, 76.		
Letter from Mr. Thomas Robertson, apologising for having interrupted the proceedings of the House by interjection, and apology accepted, 79.		
<b>REMOVAL OF RECORDS FROM CUSTODY OF THE CLERK :—</b>		
Motion made ( <i>Mr. Foster</i> ) that the Honorable Member for the Hume, Mr. Lyne, has been guilty of contempt in keeping papers laid on Table of the House in his own custody and out of custody of the Clerk, and that he be required to leave them in such custody, as required by Standing Order, documents returned, and motion by leave withdrawn, 53.		
<b>SEAT OF THE HONORABLE BERNHARD RINGROSE WISE, ESQUIRE :—</b>		
Motion made ( <i>Mr. Dibbs</i> ) to refer to Committee of Elections and Qualifications whether Mr. Wise, one of the Members for South Sydney, has not, since his election, accepted an office of emolument in having accepted a fee of fifty-five guineas from the Commissioner for Railways, in contravention of the 28th section of the Constitution Act, 53; Report brought up, 55	1	903
<b>SEAT OF JOHN HAYNES, ESQUIRE :—</b>		
Motion made ( <i>Mr. Melville</i> ) that it be referred to the Committee of Elections and Qualifications to report whether, by reason of his becoming a bankrupt or an insolvent debtor, has not and is not now vacant, and negatived, 145.		
<b>SEAT OF JOSEPH MITCHELL, ESQUIRE :—</b>		
Motion made ( <i>Mr. Copeland</i> ) to refer to Elections and Qualifications Committee the question as to corrupt practices at the last Election, and negatived, 548.		
<b>SLATTERY v. YOUNG :—</b>		
Speaker acquaints House of receipt of letter from Mr. Hourigan, Solicitor, asking him to name a Solicitor to accept on his behalf, service of a Writ issued at the instance of Mr. T. M. Slattery against him for his action in causing Mr. Slattery to be removed from the Chamber; letter read by Clerk, motion made ( <i>Sir Henry Parkes</i> ) that Mr. Speaker have leave to appear and plead, that Crown Solicitor be instructed to accept service of Writ, and that Attorney-General defend the action, 228.		
<b>NOTICE OF MOTION TO RESCIND APPOINTMENT OF MR. SPEAKER :—</b>		
Mr. Speaker ruled that motion submitted by Sir Henry Parkes, "That notice be not entered on the Votes and Proceedings, could not be moved as, 252.		
<b>GARRETT v. DIBBS :—</b>		
Motion made ( <i>Mr. Dibbs</i> ) That the Crown Solicitor be instructed to defend the action of, in the interest of the Privileges of this House, and negatived, 326.		
<b>SPEECH MADE BY MR. HAYNES :—</b>		
Mr. Melville brought under notice a statement in a speech reported in the <i>Australian Star</i> , and moved that it be read by Clerk, 364; statement read by the Clerk, and Motion made ( <i>Mr. Melville</i> ) censuring Mr. Haynes, and negatived, 365.		
<b>DISCHARGE OF MEMBER FROM CUSTODY OF SERGEANT-AT-ARMS :—</b>		
Motions made in reference to Mr. McElhone. Hon. Member admitted to the Bar to make explanation and apologise, and discharge authorized. Speaker directed Sergeant-at-Arms accordingly, 485, 486.		
<b>PRODUCTION (See "STATISTICS").</b>		
<b>PRODUCTION OF WINES (See "WINES").</b>		
<b>PRO FORMA BILL :—</b>		
Ordnance Lands Transfer Bill, presented and read 1 <sup>o</sup> , 2.		
<b>PROGRESS OF THE COLONY (See "STATISTICS").</b>		
<b>PROPERTY TAX BILL :—</b>		
Message from Governor, 234; Resolution reported from Ways and Means and agreed to; Ordered ( <i>Mr. Burns</i> ), founded on Resolution of Ways and Means presented and read 1 <sup>o</sup> , 561; Point of Order as to whether Bill was properly before the House, ruled against by Mr. Speaker, read 2 <sup>o</sup> , committed, 574; further considered in Committee, 595.	3	839
Petition presented from Banking Companies in opposition to, 586	3	841
<b>PROPOSED NEW STANDING ORDERS (See "STANDING ORDERS").</b>		
<b>PROROGATION SPEECH :—</b>		
Delivered by Governor, 643.		
<b>PROSECUTIONS UNDER THE COMPULSORY CLAUSE OF THE PUBLIC INSTRUCTION ACT :—</b>		
Information respecting, laid on Table, 437	4	501
<b>PROSPECT DAM :—</b>		
Reports of Messrs. Bishop, Whitton, and Bennett, C.Es., on, laid on Table, 529	5	849
<b>PROSPECTING FOR GOLD AND OTHER MINERALS (See "MINING").</b>		
<b>PRUEN, REGINA v. (See "ADMINISTRATION OF JUSTICE").</b>		
<b>PUBLIC AMUSEMENT HALLS (See "PLACES OF PUBLIC AMUSEMENT OR RESORT").</b>		
<b>PUBLIC BUILDINGS :—</b>		
<b>TOWNS OF FORBES AND PARKES :—</b>		
Return showing expenditure on, laid on Table, 578	8	1305
<b>PUBLIC CHARITIES (See "CHARITIES").</b>		
<b>PUBLIC HOUSES (See "LICENSING ACT").</b>		
<b>PUBLIC INSTRUCTION ACT (See "EDUCATION").</b>		
<b>PUBLIC LANDS BILL (See "CROWN LANDS BILL").</b>		
<b>PUBLIC PARKS (See "PARKS").</b>		
<b>PUBLIC PARKS ACT :—</b>		
Proclamation under, extinguishing as a public highway part of the St. Leonards Recreation Reserve, laid on Table, 6	5	811
<b>PUBLIC PURPOSES (See "CROWN LANDS").</b>		
<b>PUBLIC SCHOOL (See "EDUCATION").</b>		
<b>PUBLIC TANKS AND WELLS :—</b>		
<b>CONSTRUCTION AND MAINTENANCE OF :—</b>		
Motion made ( <i>Mr. Waddell</i> ) that so much of the Return ( <i>in part</i> ) to Order ( <i>Session 1883-4</i> ) laid on Table on 19 November, 1884, as relatives to Galathera and Boggy Creek, be printed, 174	8	49
Motion made ( <i>Mr. Waddell</i> ) for all papers, minutes, and reports in reference to complaints of officers of the Mines Department against Mr. Bennett, Commissioner and Engineer for Roads, respecting, and all correspondence respecting loss and inconvenience through works of, being divided between the Works and Mines Departments, 174; Return to Order, laid on Table, 252	8	671
<b>DAYSDALE :—</b>		
Notification of Resumption of land for, laid on Table, 145	8	951

REFERENCES TO THE VOTES AND PROCEEDINGS, VOL. I—13TH PARLIAMENT—SESSION, 1887-8.	PAPERS.	
	VOL.	PAGE.
<b>P</b>		
<b>PUBLIC VEHICLES REGULATION ACT AMENDMENT BILL:—</b> Motion made ( <i>Dr. Wilkinson</i> ) for leave to bring in, 361.		
<b>PUBLIC WHARF</b> (See "WHARVES").		
<b>PUBLIC WORKS</b> (See also "HOSPITALS"; also "PARLIAMENTARY STANDING COMMITTEE ON PUBLIC WORKS").		
<b>PARLIAMENTARY STANDING COMMITTEE:—</b> Motion made ( <i>Mr. Sutherland</i> ) for appointment of, as provided under Public Works Act of 1888, appointed by Ballot, 508.		
<b>PUBLIC WORKS BILL:—</b> Motion made ( <i>Mr. Henry Parkes</i> ) for Committee of the Whole, 52; House in Committee, and Resolution agreed to, 115; Message from Governor, 135; presented and read 1 <sup>o</sup> , 150; Order of the Day, postponed, 229; motion made for 2 <sup>o</sup> , and debate adjourned, 259; resumed, read 2 <sup>o</sup> , and committed, 264; further considered in Committee, 277; further considered in Committee, reported and Report adopted, 281; Order of the Day, postponed, 309, 314, 335, 338, 365; recommitted, reported with further amendments, report adopted, 373; read 3 <sup>o</sup> , passed, sent to Council, 380; returned with amendments, 442; amendments agreed to (including an amendment in the Title) and message to Council, 463; assent reported, 492.	8	1250
<b>PUBLIC WORKS LOAN BILL:—</b> Ordered ( <i>Mr. Burns</i> ), founded on Resolution of Ways and Means, No. 13; presented and read 1 <sup>o</sup> , 628; read 2 <sup>o</sup> , committed, reported with an amendment and report adopted, read 3 <sup>o</sup> , passed, and sent to Council, 640; returned without amendment, 642; assented to in Legislative Council Chamber, 642.		
<b>PUBLIC WORKS DEPARTMENT</b> (See also "CIVIL SERVICE"):— <b>TENDERS CALLED FOR, BY:—</b> Return to Order ( <i>Second Session</i> , 1887), laid on Table, 6	6	707
<b>PURCHASE BY THE GOVERNMENT:—</b> <b>OF LAND ADJOINING THE AUSTRALASIAN STEAM NAVIGATION COMPANY'S WHARF:—</b> Motion made ( <i>Mr. Melville</i> ) for a Select Committee to inquire into, Committee appointed by Ballot, 30. Report brought up, 305	3	917
Motion made ( <i>Mr. Dibbs</i> ) for an Address to the Governor, that the evidence taken discloses injudicious and unsatisfactory administration by the Government, and that the amount paid was in excess of its value, 329.	3	1011
Correspondence respecting, laid on Table, and referred to Select Committee, 51	3	1013
<b>AUSTRALASIAN STEAM NAVIGATION COMPANY'S PROPERTY:—</b> Motion made ( <i>Mr. Trickett</i> ) for all claims, correspondence, valuations, &c., connected with, 136; Return to Order, laid on Table, 191	3	1013
<b>PRECEDENCE OF NOTICE OF MOTION:—</b> Motion made ( <i>Mr. Dibbs</i> ) for, 323.		
<b>IRON AND STEEL RAILWAY AND TRAMWAY MATERIALS:—</b> Motion made ( <i>Mr. Fletcher</i> ) for return showing particulars of, 479.		
<b>PURFLEET</b> (See "ROADS").		
<b>Q</b>		
<b>QUARANTINE STATION:—</b> Motion made ( <i>Mr. Lyne</i> ) for all papers, letters, &c., in reference to removal of, at North Head, 241; Return to Order, laid on Table, 263	2	241
Motion made ( <i>Mr. See</i> ) for papers, &c., in reference to removal of, 573.		
<b>QUARRIES</b> (See "PARRAMATTA MUNICIPAL QUARRIES BILL"; also "STATE QUARRIES").		
<b>QUEANBEYAN</b> (See "STAMP DUTIES ACT").		
<b>QUEEN, HER MAJESTY THE</b> (See "ADDRESS").		
<b>"QUESTION BE NOW PUT":—</b> Motion made, and passed, 24 <sup>(2)</sup> , 156, 220, 221, 222, 468, 485. Do. and withdrawn, 156-7. Do. and negatived, 493, 530. Do. and Teller's List showing less than forty members in favour of, 468. Ruling of Mr. Speaker that when there are no voices for the Noes, having satisfied himself that forty members are present, it is not necessary to take a division, 24; dissent from ruling moved ( <i>Mr. Dibbs</i> ) and negatived, 25.		
<b>QUESTIONS:—</b> <b>AND ANSWERS:—</b> Sessional Order passed, 10.		

## Q

## QUESTIONS AND ANSWERS:—

- ABATTOIRS:—**  
Removal of, from Glebe Island, 7, 14.  
Leasing of Glebe Island, 206.  
Condition and Management of, 213.  
Dismissal of Mr. Read from Glebe Island, 333.
- ABERDEEN:—**  
Bridge over Hunter at, 559.
- ABIGAIL, THE HON. FRANCIS, M.P.:—**  
Ownership of land near Pittwater Tramway, 155.  
Sleeping-car for accommodation of, 402.
- ABORIGINES:—**  
Occupancy of Moira Forest Reserve by, 122.  
River Murray, 285.  
La Perouse, 591.
- ACCIDENT:—**  
Railway, at Peat's Ferry, 74, 118, 265, 276, 632.  
To s.s. "Alhambra," 564.
- ACCOUNTS, PUBLIC (See "FINANCE")**
- ADAMINABY:—**Recreation Reserve, 96.
- ADDISON, MR., STIPENDIARY MAGISTRATE:—**  
Complaints against, 167.  
Cases dealt with by, at one sitting, 173.
- ADELAIDE:—**Jubilee Exhibition, 94, 133, 134, 190, 262, 495.
- ADMINISTRATION OF JUSTICE:—**  
Nominations to the Magistracy, 8(2), 21, 57.  
Licensing Magistrates acting on Magisterial Bench, 69, 163.  
Stipendiary and Deputy Stipendiary Magistrates, 167, 173, 190, 215, 331.  
Regulations for admission to the Bar, 8.  
Regina v. Pruen, 8, 79.  
Mount Rennie convicts, 28.  
District Court Bailiffs, 45.  
Sheriff's Bailiffs mileage charges, 209.  
Trials in District Courts, 133.  
Wilkinson's Australian Magistrate, 45.  
Jurors, District Court, Cooma, 68.  
Employment by the Government of—  
Hon. E. Barton, M.L.C., 80.  
Dr. Sly, 101(2), 110.  
Sheriff's Officers, 83.  
Court of Quarter Sessions, Bombala, 223, 256.  
Do. Muswellbrook and Singleton, 218.  
Court of Petty Sessions, Manly, 88.  
Charge for Subpœnas, 110.  
The Attorney-General, 51, 73, 110, 141, 245.  
Supreme Court Appeals Act, 117.  
Prosecutions before Juries, 139.  
Release of Prisoners, Centenary Celebration, 164.  
Sentence passed on T. B. Giles, 227.  
Fees paid to Mr. John Armstrong, Barrister-at-Law, 255, 262.  
Quarter Sessions, Lock-up, and Gaol for Bombala, 256.  
Case of J. A. H. Poulton, 265, 377, 384.  
Mr. Manning, Coroner at Ryde, 270.  
Commission of the Peace, 292.  
Alteration in system of summoning Jury List, 312.  
Court-house, Lawrence—Court-house, Maclean, 312.  
Supersedeas to Bankrupt Justices of the Peace, 319.  
Decree re Stephen v. Erwin, 332, 511.  
Case of Queen v. Bowler, 334.  
Furniture for Court-house, Narrabri, 339.  
Magistrates, Young District, 341.  
Prisoner Holt, 360.  
Captain's Flat, Site for Police Court, 367.  
Commissioner for Affidavits, Moama, 367.  
Court-house, Silverton, 372.  
Body, Mr. John E., Cooma, 387.  
Court-house, Redfern, 413.  
Court of Petty Sessions, Leichhardt, 413.  
Police Magistrate at Parramatta, appointment of, 420.  
Clerk of Petty Sessions, Murrumburrah, 436.  
Case of Dorn v. Dorn, 436.  
Visiting Magistrate, Norfolk Island, 436.  
Fees of Clerk of Petty Sessions, 449.  
Prisoner Healy, 472.  
Mr. William Thomas, J.P., of Forbes, 541.  
Mr. Giles, P.M., Bombala, 556, 578.  
Case tried before Police Magistrate at Lismore, 575.  
Court-house, Wilcannia, 577(2).  
Cost of Law Suits in which Crown is successful, 598.  
Bench of Magistrates, Michelago, 613.
- ADULTERATION OF FOOD AND LIQUORS:—**Bill dealing with, 34.
- ADVERTISING:—**On Tram-motors, 97.
- AGENT-GENERAL:—**Appointment of, 401.

## QUESTIONS—(continued):—

- AGRICULTURAL (See also "FARM PRODUCE")**  
Show Grounds, Queanbeyan, 56.  
Centennial Show, 164.  
Resources of various districts, 453.  
Societies, 371, 459.  
Model Farms, 48, 63.  
Schools and Model Farms, 267.
- AHEEN, MR. JOHN:—**  
Tenders for contract for Cast-iron Syphon, George-street West, 606.
- AIRBY, CAPTAIN H. P.:—**Promotion of, to rank of Brevet-Major, 189.
- ALBURY (See also "CROWN LANDS"):—**  
Lands Office, 419.  
Water Supply Railway Station, 584.
- ALEXANDRIA:—**  
Measles and Typhoid Fever in, 111.  
Drainage of Borough, 412.  
Public School Accommodation, 591.
- "ALHAMBRA" s.s.:—**  
Accident to and loss of, 564.
- ALT-STREET, ASHFIELD (See "RAILWAYS")**
- ALLEN, MR. W. J., M.L.A.:—**  
Railway Fares of Ladies accompanying to Bourke, 612.
- AMMUNITION (See "MILITARY")**
- ANALYST, GOVERNMENT:—**Appointment of Mr. Hamlet, 34.
- APPEALS:—**Determined under Supreme Court Appeals Act, 117.
- AQUARIUMS:—**Bondi, Cogee, and Manly, 533, 553.
- ARBITRATION CASE:—**  
Commissioner for Railways v. The Hon. John Smith, 51, 80, 96, 102.  
M'Sharry v. Commissioner for Railways, 37, 96, 319.  
The Hon. S. Charles, M.L.C., v. Commissioner for Railways, 101(2), 110.
- ARDILL, MR. JOHN ROCHE:—**Case of, 395.
- ARMIDALE:—**Centennial Celebration, 529.
- ARMOUR PLATE:—**For Defence Works, 205.
- ARMSTRONG, MR. JOHN, BARRISTER-AT-LAW:—**Fees paid to, 255, 262.
- ARNCLIFFE:—**  
Public School, 134.  
Park, 572.
- ARNHEIM AND MATHESON, MESSRS.:—**Tin Lease of, Silverton, 142.
- ASHFIELD:—**  
And Druitt Town Tramway, 57.  
Sub-way at Alt-street, 275.
- ASHFIELD STATION:—**Train arrangements, 344.
- ASSAYER:—**Government, and Assistant Assayer, 34.
- ASSAYS (See "MINING")**
- ASSEMBLY:—**  
Electric Light in the Chamber, 32, 39, 68.  
Hour of Meeting, 207.  
Payment of Members of, 256.
- ASSISTANT EXAMINER OF ACCOUNTS, TREASURY:—**Application for position of, 473.
- ASSIGNEES OFFICIAL:—**  
Alleged misconduct of, 613.
- ASSOCIATION CRICKET GROUND:—**Trustees of, 447, 518, 541, 569, 589.
- ASSURANCE FUND:—**Real Property Act, 179, 207, 261, 305, 341, 459.
- ASYLUMS:—**  
Reports as to management of Government, 7.  
Dismissal of Warder Nagle, 21.  
Newington, Inquiry, 240, 290.  
Newington and Parramatta, 337.  
For Insane, Parramatta North, 343, 521.
- ATHENEUM AT WILCANNIA:—**Subsidy to, 364.
- ATTENDANCE OFFICERS (See "EDUCATION")**
- ATTORNEY-GENERAL:—**  
Fees received by, for appearing in Crown Cases, 51, 73, 245.  
Patent Fees received by each, since Responsible Government, 110, 141.  
Acting Secretary to, 558.
- AUBURN:—**  
Crossing at Station, 313.  
Park Road Trust, 424.
- AUDIT DEPARTMENT:—**Promotions in, 183.
- AUGER DRILLS:—**Amount due for use of, 261.
- AUSTRALASIAN STEAM NAVIGATION COMPANY:—**  
Purchase of Wharf by the Government, 8.  
Rumoured purchase of Works, Pyrmont, by the Government, 8.  
Purchase of land between Wharf and Dawes Point, by the Government, 56.

## Q

## QUESTIONS—(continued):—

- AUSTRALIAN AGRICULTURAL COMPANY:—Road through Land at Warrarah, 167.
- AUSTRALIAN GASLIGHT COMPANY:—Incorporation of, 106.
- “AUSTRALIAN MAGISTRATE”:—Supply of, to Benches, 45.
- BACON DUTY (See “CUSTOMS”)
- BAILIFFS:—  
Of District Courts, 45.  
Mileage Rates charged by Sheriff’s, 209.
- BALRANALD (See “CROWN LANDS,” also “RABBIT PEST”)
- BALIS’S SELECTIONS (See “CROWN LANDS”)
- BANK PASS BOOKS:—Transmission of, by post, 184.
- BANKERS:—Business of, 400.
- BANKRUPTCY ACT:—Moneys in the hand of Government, 471.
- BANQUET:—Centennial, 256.
- BAR, THE:—Regulations for admission to, 8.
- BARCOM GLEN ESTATE:—Resumption of portion of, 127.
- BARLING MR.:—Length of service of, 142.
- BARRABA (See also “ROADS”):—  
Temporary Common, 167.
- BARRINGUN:—Rabbit-proof Fencing between Bourke and, 218.
- BARTON, MR. G. B., (See “Official History of New South Wales.”)
- BARTON, THE HON. EDMUND, M.L.C.:—Employment of, by the Government, to prosecute, 80.
- BARWON:—Bridge over at Brewarrina, 403.
- BATE’S SELECTION (See “CROWN LANDS”)
- BATHURST (See also “RAILWAYS.”)  
Railway Station—Over-bridge, 15.  
Do Hay Loading Stage, 81.  
Do Payment of Wages by Stationmaster, 394.  
Railway to Bourke, 535, 564.  
Embankment near Railway Bridge, 81.  
Officers of District Engineer’s Staff, 271.  
New Gaol at, 271.  
Burr, Destruction of, 272.  
Employés in Railway Workshops, 290, 428.  
Railway Workshops, 618.
- BEDLAM CREEK (See “BRIDGES”)
- BEER:—Duties paid on, 31.
- BEGA-EDEN RAILWAY:—Plans and books of reference, 332.
- BELABULA (See “ROADS”)
- BELAR CREEK:—Road, parish of Deringullen, 168, 340.
- BELL, SUB-INSPECTOR (See “POLICE”)
- BELMORE:—Recreation Ground, 292.
- BELMORE PARK:—Tramway crossings, 110.
- BELFREES STATION:—Selections made on, 384.
- BENEVOLENT ASYLUM:—Site for, Parramatta North, 343.
- BETTING SWEEPS:—And “Consultations,” 218.
- BILLIARD LICENSE:—  
William Spangenberg’s application for, 38 (?).  
District of Marrickville, 270.
- BINGERA:—Crown Lands Sale at, 235.
- BLACKFRIAR’S ESTATE:—Condition of streets and lanes, 427.
- BIRTHS:—District Registrars of, 411.
- BLACK, MR. JOHN:—Property resumed on Homebush-Waratah line, 523.
- BLAYNEY:—Railway Station, 332.
- BLOXSOME, MR. REGINALD:—Appointment of as Secretary Metropolitan Water and Sewerage Board, 368.
- BLUE METAL:—Railway haulage rate, from Emu Plains, 47.
- BOARDS OF INQUIRY:—  
Statistics of, 205.  
Collieries, 489.  
Phylloxera, 490.
- BOARD OF RAILWAY COMMISSIONERS:—Appointment of, 536.
- BOATS:—For Richmond River, 292.
- BODY, MR. JOHN E.:—Appointment of, to Licensing Court, Cooma, 387.
- BOGAN RIVER:—Road from Narramine, 51.
- BOLTON MR. JOSEPH:—Complaint against Mr. W. H. Margil, 607.
- BOMBALA:—  
Court of Quarter Sessions, 223, 256.  
Lock-up Gaol, 256.  
Mr. Giles, P.M., 556, 578.
- BONDI:—  
Sewer, 126, 154.  
Foreshores of, 134.  
Aquarium, 533, 553.
- BONDED WAREHOUSES:—Kerosene Oil, &c., in, 491.
- BORE (See “WATER SUPPLY”)
- BORE TO PARKES (See “ROADS”)
- BORENORE:—  
Railway Goods Traffic, 559.  
Railway *via*, 597.
- BORING OPERATIONS:—Clarence Siding, 498.

## QUESTIONS—(continued):—

- BOTANY:—  
Nuisance of Seaweed at, 32, 70, 333, 412.  
Professor of, and Lectures on, 94.  
Celebration of the Centenary of the Colony at, 117.  
Public Wharves, 411.  
Lighting Road, 412.  
Road, Tram-line, 413.  
Road, 474.
- BOURKE (See also “CROWN LANDS,” also “RABBIT PEST”):—  
Prisoners in gaol, 31.  
Customs duties collected at, 38.  
Court-house, 56.  
Disease in Stock in district, 81.  
Railway Goods Charges to Byrock and, 195.  
Post and Telegraph Office, 39, 215, 498.  
Rabbit-proof Fencing between Barringun and, 218.  
Town Common, 284.  
Railway from Bathurst, 564.  
Telegraph to Wanaring, 541.  
Erection of Wharf, 598.
- BOTCHER AND PARTY (See “MINING”)
- BOWLER, QUEEN *v.* (See “ADMINISTRATION OF JUSTICE”)
- BOWRAL:—Railway Station, 472, 558.
- BOXING MATCHES:—Suppression of, 312.
- BOYS REFORMATORY:—Establishment of, 28, 331.
- BRADLEY’S HEAD:—Resumption of Land near, 14.
- BRAIDWOOD:—Post and Telegraph Master at, 473.
- BRAINE, ALFRED:—Timber Inspector, Cooma Railway, 125.
- BRAKES:—Railway, 74, 388, 632.
- BRASS FITTINGS:—For Water Supply purposes, 218.
- BREWARRINA:—  
Customs Duties collected at, 38.  
Bridge over Barwon at, 403.
- BRIDGES:—  
Roads and, in Electorate of The Richmond, 21.  
Iron Cove, 21, 424, 460.  
Middle Harbour, at the Spit, 27.  
River Murray, at Mulwala, 27, 275.  
Over Upper Murray, 34, 275, 301.  
Turon River, at Wallaby Rock, 48.  
Iron for, Roads Department, 62, 213.  
Dilga Creek, Road Cumnock to Baldary, 62.  
Eugowra Creek, 118.  
Moama, over Murray River, 122, 290, 364.  
Mangrove Creek, Hawkesbury River, 149.  
On Road Menindie to Kinchega, 154.  
Wyang Creek, Bedlam Creek, 262.  
Hunter River, at Hillsborough, 275.  
Do at Aberdeen, 559.  
Hawkesbury Railway, 284, 293, 307, 319, 331, 337, 355, 359, 533.  
Duck River, 291.  
Darling at Wilcannia, 311, 528.  
Tarban Creek, 313.  
Over Barwon at Brewarrina, 403.  
Parramatta River, 424.  
Iron, Cost of, 432.  
Narandera, 518.  
Castlereagh River, 611.
- BRIGADE OFFICE (See “MILITARY.”)
- BROKEN HILL:—  
Height above sea level, 163.  
Post and Telegraph Offices at, 266, 428.
- BROWN, MR. JOHN (See “CROWN LANDS”)
- BROWN, MR. H. H., M.P.:—Horses purchased from by Telegraph Department, 271, 459, 512.
- BROWN, MR. THOMAS (See “CROWN LANDS”)
- BRUSH CARBONS:—Supply of, 46.
- BRUSHGROVE:—Trustees for Recreation Reserve at, 121.
- BULGA ROAD:—Alienation of Reserve on Stock Road, 139, 163, 251.
- “BULLETIN, THE”:—Alleged prohibition of, in the Barracks, 56.
- BULLI COLLIERY:—  
Report on Disaster at, 7.  
Opinion of Attorney-General, *re* Explosion, 33.
- BUNGABEE NOBAH:—Proposed Lighthouse on, 93.
- BUOY:—Off Dobroyd Point, 134.
- BURADOO:—Platform, 518.
- BURGLARIES:—In Western Suburbs, 618.
- BURRABOGUE RUN:—Rent fixed, 84.
- BURRAWONG RUN:—Destruction of Timber on, 52.
- BUTTER DUTY (See “CUSTOMS”)
- BUTTERINE:—Sale of, 542.
- BYROCK:—  
Water Supply, 38.  
Town Common, 38, 195.  
Road to Gongolgan, 183, 279.  
Railway Goods Charges to Bourke and, 195.



## Q

## QUESTIONS—(continued) :—

- CABLE COMMUNICATION (See "TELEGRAPHS.")
- CAMPBELL MR. JAMES LANG :—Acting Secretary to Attorney-General, 558.
- CAMPERDOWN :—Application of Municipal Council to borrow, 189, 205.
- CANNELL, MR. E. :—Contract for Road near Stone Quarry Creek Crossing, 105.
- CANLEY VALE PLATFORM :—Officer in charge at, 313.
- CANOWINDEA :—Travelling Stock Reserve on Eugowra Road, 179.
- CAPITATION ALLOWANCE (See "VOLUNTEERS")
- CAPTAIN'S FLAT :—  
Village Reserve at, 47, 279.  
Purchase of Land at, 154.  
Mineral Leases at, 155, 280, 291, 367.  
Site for Police Court, 367.  
Business Licenses, 607.
- CARCOAR :—Road to Mount Macquarie, 34.
- CARTAGE :—Wool Produce, &c., from Darling Harbour, 546.
- CARELESS USE OF FIRE :—Prosecutions and convictions under, Act, 331.
- CARGO (See also "CROWN LANDS") :—  
Land sale at Cheeseman's Creek and, 218.
- CARRINGTON GROUNDS :—Betting and gambling at, 348.
- CARS (See "TRAMWAYS")
- CARVER, MR. NICHOLAS P. :—Railway Surveyor, 96.
- CASINO :—  
Payment of the Unemployed by Council, 75.  
Prison Labour in Gaol, 490.  
Land Board, 497.
- CASSILLS :—  
Railway Extension beyond, 79.  
Railway Trial Survey from Singleton, *via* Jerry's Plains, 448.  
Railway from Muswellbrook, 556, 559.
- CASTINGS (See "HARBOUR AND RIVERS DEPARTMENT NEWCASTLE")
- CASTLEREAGH RIVER :—Bridge over, 611.
- CASUAL LABOUR BOARD :—  
Particulars of, 33.  
Expenditure of, &c., 125.
- CATTLE :—Regulations respecting, sent from New South Wales to Victoria, 180.
- CATTLE TRUCKS (See "RAILWAYS")
- CAVALRY CORPS :—Uniforms, &c., for Country, 497.
- CAVANOUGH, FREDERICK :—Appointment to the Railway Department, 428.
- CEMETERIES :—  
Devonshire-street, 84, 101.  
Rookwood and Waverley, C.E. Chaplains, 141.  
Presbyterian, Liverpool, 227, 235.
- CENTENARY OF THE COLONY (See also "MELBOURNE EXHIBITION") :—  
Celebration at Botany, 117.  
Competition in Designs for State House, 155.  
Release of Prisoners, 164.  
Agricultural Show, 164.  
Banquet, 256.  
Relief to Poor of Sydney, 291.  
Medals for Commissioners, 301.  
Authority for payment of cost of State House, 355.  
State House, Erection of, 383.  
Celebrations, 424.  
Railway Return Tickets issued in connection with Exhibition, 448.  
Armidale Celebration, 529.
- CENTENNIAL (See "CENTENARY OF THE COLONY")
- CENTENNIAL PARK :—  
Land taken from Sydney Common, 300.  
Amount paid in connection with, 352.  
Gateways to Borough of Waverley, 478.
- CENTRAL POLICE OFFICE :—Officers in, 223.
- CHANGING-PLACES (See "RAILWAYS")
- "CHANGSHA," S.S. :—Illegal landing of Chinese from, 395.
- CHAPLAINS :—Church of England, Rookwood and Waverley Cemeteries, 141.
- CHEESE DUTY (See "CUSTOMS")
- CHESEMAN'S CREEK :—Land Sale at Cargo and, 218.
- CHICKEN CHOLERA (See "RABBIT PEST")
- CHINESE :—  
Employment on Relief Works, 16.  
Restriction of Immigration, 20.  
Naturalization of, 63.  
Visit of Commissioners, 95.  
Tram Time-tables in language, 333.  
Fine for illegally landing from s.s. "Changsha," 395.
- CHLOROFORM :—Deaths while under influence of, 270.
- CHRISTMAS DAY :—Opening public-houses on, 227.

## QUESTIONS—(continued) :—

- CHURCH AND SCHOOL LANDS DEDICATION BILL :—Introduction of, 33.
- CHURCH AND SCHOOL LANDS :—  
Introduction of Bill for Mining on, 313, 377.  
Dedication Bill, 557.
- CIRCULAR QUAY :—  
Extension of Railway to, 178.  
Quit-rent on Cunninghame's Grant, 184.  
Wood-paving, 301.  
Mr. Norman Selfe, Improvements at, 388.
- CITY :—Railway from Redfern into, 512.
- CIVIL SERVICE :—  
Department of Public Works, 13, 142.  
Department of Lands, 13.  
Department of Mines, 21, 33.  
Department of Audit, 183.  
Superannuation Fund, 38.  
Registrar-General's Department, 63.  
Customs Department, 75, 110, 143.  
Telegraph Department, 111, 529.  
Salaries of Clerks of Petty Sessions, 134, 235, 474.  
Regulation fixing Hours of Attendance, 149.  
Mr. Thomson, Chief Inspector of Accounts, 153.  
Clerks in Roads Department, 168.  
Mr. Macarthur, late P.M., Corowa, 180.  
Comparative Statement of Salaries and Wages, 207.  
Deductions from Salaries of, 223, 324.  
Mr. Foskett, Stamp Office, 214, 299.  
Officers in Central Police Office, 223.  
Police Magistrates appointed Wardens under the Mining Act, 227, 245.  
Commission to enquire into, 245, 511.  
Vouchers for moneys paid by Public Officials, 251.  
Holidays in General Post Office, 272, 356, 489, 556.  
Mr. Samuel Hawthorne, employment of, 283.  
Salaries paid at same rates as 1887, 293.  
Mr. O'Malley Clarke, leave of absence, 299, 351.  
Appointment of Locomotive Engineer, 327, 477, 484.  
Mr. Yates, leave of absence, 351.  
Mr. Dalglish, district surveyor, 352.  
Salaries for month of March, 356.  
Public Holidays for Classified Officers of Railway Department, 402.  
Mr. Charles Cutcliffe, Clerk of Petty Sessions, Murrumburrah, 436.  
Fees to Clerks of Petty Sessions, 449.  
Annual increase to salaries of certain, 454.  
Salaries, Pension Fund, 460.  
Assistant Examiner of Accounts, Treasurer, 473.  
Removal by Mr. A. Moriarty of pay-sheets from Harbours and Rivers Department, 495.  
Mr. G. S. Ridley, 522.  
Messrs. G. F. Wise and F. B. Treatt, 534.  
Mr. C. Colls, Railway Department, 536.  
Mr. James Lang Campbell, 558.  
Persons entitled to Pensions, 591.  
Appointments of sons of Ms.P. to, 606.  
Officers in Public Instruction Department over age of 60 years, 633.  
Increments to Salaries of Telegraph Operators, 634.
- CIVIL SERVICE ACT :—  
Provision for Officers about retiring in event of repeal of, 94.  
Actuaries consulted when framing, 214.  
Refund of contributions, 324.  
Actuarial investigation into state of Superannuation Account, 324.  
Salaries and Pension Fund, 460.
- CLARENCE RIVER :—  
Local Land Board, 55.  
Seed Potatoes supplied to persons in Electorate, 171.  
Improvements at, 324.
- CLARENCE SIDING :—  
Diamond Drill at, 102, 190, 207.  
Boring operations, 498.
- CLARKE, MR. O'MALLEY :—Leave of absence, 299.
- CLARKE, MR. WILLIAM, M.P. :—Appointment of as Agent-General, 401.
- CLERKS OF PETTY SESSIONS :—  
Salaries of, 134, 235, 474.  
Fees under Act, 449.
- CLIBBORN, MR. :—Railway Free Pass to, 385, 401, 440.
- CLIFFORD, MR. J. J. :—Appointment of, as J.P., 8.
- CLOAK ROOM :—  
Sydney Railway Station, 545.
- COAL (See "RAILWAYS," also "MINING")
- COAL CLIFF COLLIERY COMPANY :—Connection of Mr. Charles Cowper, Sheriff, with, 111.

# INDEX.

REFERENCES TO THE VOTES AND PROCEEDINGS, VOL. I.—13TH PARLIAMENT—SESSION, 1887-8.

## Q

### QUESTIONS—(continued)—

- COAL-FIELDS (See also "COLLIERIES") :—  
 Mr. Mackenzie, Examiner of, 7, 14, 20, 33 (?).  
 COAL-MINES REGULATION ACT :—Amending Bill, 14.  
 COBAR (See also "WATER SUPPLY") :—  
 Railway from Nyngan, 215.  
 Mineral Leases, District of, 458.  
 COBARGO :—Post and Telegraph Office, 96.  
 COHEN, Mr. E. N. :—Promotion of, in Central Police Office, 223.  
 COLLIERIES :—  
 Report on Bulli Disaster, 7, 33.  
 Board of Inquiry into, 489.  
 COLIS, Mr. C. :—Railway Department, 536.  
 COLONIAL AND INDIAN EXHIBITION :—Expenditure on, 126.  
 COLONIAL IRON :—Result of tests, 167.  
 COLONIAL SECRETARY :—Visit of, to Northumberland, 9.  
 COLONY :—Change in name of, 184.  
 COLO VALLEY :—Railway Trial Survey by way of, 80, 266, 319.  
 COMBINATION TRUCKS (See "RAILWAYS")  
 COMMISSIONS :—  
 Adelaide Jubilee Exhibition, 133.  
 Statistics of Royal, 205.  
 To enquire into Civil Service, 245, 511.  
 Destruction of Rabbits, 290.  
 Melbourne Exhibition, 372.  
 Secretary, Rabbit Pest, 406.  
 Transit, 457.  
 Intoxicating Drink Inquiry, 460.  
 COMMISSION :—Of the Peace, 292.  
 COMMISSIONERS (See also "TRANSIT COMMISSIONERS," also "RAILWAYS") :—  
 Adelaide Jubilee Exhibition, 94, 134, 190, 262, 495.  
 COMMISSIONER FOR AFFIDAVITS :—Moama, 369.  
 COMMONS :—  
 Town, Byrock, 38, 195.  
 Do. Bourke, 284.  
 Moama, 164.  
 Temporary, Barraba, 167.  
 Do. Albury, 261.  
 Richmond, 214.  
 Wallabadah, 337.  
 Pillaga, 339.  
 COMPENSATION :—Improvements, under Crown Lands Bill (No. 2), 364.  
 CONDITIONAL PURCHASES (See "CROWN LANDS")  
 Returns respecting, 395.  
 CONDOBOLIN :—  
 Schools near Railway Line to, 558.  
 Post and Telegraph Office, 559.  
 Railway Line to, 575, 605, 617.  
 Land Board, 592.  
 CONFERENCE :—Destruction of Rabbits, 364, 372.  
 CONSERVATION OF WATER :—  
 Supervision of Construction of Tanks, &c., 61.  
 Carrying out proposals of Royal Commission, 172.  
 CONSOLIDATED REVENUE FUND (See "FINANCE")  
 CONSOLIDATED REVENUES :—Of Great Powers of Europe, America, Canada, and Australasian Colonies, 109.  
 CONSTRUCTION OF LOCOMOTIVES :—  
 By the Baldwin Company, 327.  
 In the Colony, 6, 47, 110, 144, 413, 480, 495.  
 "CONSULTATIONS" :—And Betting Sweeps, 218.  
 CONTESTS (See "EXHIBITION CONTESTS")  
 CONTRACTORS :—Payment of Road, 39.  
 CONTRACTS :—  
 Given to Messrs. Hudson Bros., without competition, 69.  
 Payments under, to Messrs. Kidman, 272.  
 Postal, with Pacific Mail Steamship Company, 239, 319.  
 Road, Mr. Wells, 448.  
 CONVICTS (See "ADMINISTRATION OF JUSTICE")  
 COOK'S RIVER :—  
 Flooding of Murrickville and Tempe through Railway Bridge over, 179.  
 Reclamation Work, 262.  
 COODE, SIR JOHN :—  
 Improvements at Clarence River, 324, 498.  
 Improvements, Richmond River entrance, 458.  
 Report on Crookhaven Heads, 572.  
 COOGEE BAY :—  
 Sea-wall at, 106.  
 Aquarium, 533.  
 COOKSON, Mr. :—Schoolmaster at Seven Hills, 528.  
 COOLE, EDWARD :—Railway Ticket Collector, 293.  
 COOMA (See also "RAILWAYS") :—  
 Jurors, District Court, 68.  
 Recreation Ground, 96.  
 COONABABRAN (See "CROWN LANDS")

### QUESTIONS—(continued)—

- COONAMBLE :—Road to Pilliga, 339.  
 COOTAMUNDRA :—Post and Telegraph Master at, 473.  
 COPYRIGHT :—Correspondence respecting application of Imperial Statute, 173.  
 COROWA :—  
 Mr. Macarthur, late Acting Police Magistrate at, 180.  
 Police Barracks, 395.  
 COSTS (See "ADMINISTRATION OF JUSTICE")  
 COUNSEL'S FEES :—Paid to Attorney-General, 51, 73.  
 COUNTRY DISTRICTS :—Public Expenditure in Sydney and, 7.  
 COUNTRY TOWNS :—Stray Cattle in, 33.  
 COUNTY RESERVE CORPS (See "MILITARY")  
 COURT-HOUSE :—  
 Bourke, 56.  
 Eastern Suburbs, 96, 168.  
 St. Albans, 178.  
 Junee, 184.  
 Lawrence, 312.  
 McLean, 312.  
 Narrabri, 339.  
 Silverton, 372.  
 Redfern, 413.  
 Wilcannia, 577 (?).  
 COURT OF PETTY SESSIONS :—Manly, 88.  
 COURTS OF QUARTER SESSIONS :—  
 Muswellbrook and Singleton, 218.  
 Bombala, 223.  
 COUSINS, Mr. R. :—Land sold by the Government to, 184.  
 COWPER, Mr. CHARLES, SHERIFF :—Action of, in connection with Coal Cliff Colliery Company, 111.  
 COWRA :—  
 Licensing Bench, Refusal of license to Mr. Galvin, 396.  
 Railway Goods Traffic, 559.  
 COX'S RIVER :—Survey of Railway to Oberon, *via*, 343.  
 CRACE, E. K. :—Road through Estate of, at Gungahleen, 139, 140, 436.  
 CRACKNELL, Mr. :—  
 Operating Room, Telegraph Department, 453.  
 Cable for Frieze-work, 453.  
 CREED, Dr. :—Speech on Defences of the Colony, 522.  
 CREMORNE :—Reservation of Shores of Robertson's Point, 153.  
 CRICKET GROUND (See "ASSOCIATION CRICKET GROUND")  
 CROOKED CREEK :—Proposed Works at, 618.  
 CROOKWELL :—Railway from Goulburn, 88, 450.  
 CROSSING AT AUBURN STATION :—Dangerous state of, 313.  
 CROWN LANDS (See also "RESERVES") :—  
 Department, 13, 270.  
 Over-payment of Rent by Pastoral Tenants, 14.  
 Rental of Pastoral Leaseholds and Resumed Areas in Central District, 88.  
 Pastoral and Homestead Leases, Western Division, 105.  
 Pastoral and Homestead Leases, Rent from, 189.  
 Arrears of Rent for Runs, 149, 255.  
 Arrears due by Pastoral Lessees, 408.  
 Runs and homestead leases abandoned and improved land taken up under Act of 1884, 150.  
 Transfers of Conditional Purchases, 154, 172.  
 Unleased Runs in Western Division, 178.  
 Occupation Licenses, 178.  
 Pastoral Leases and Occupation Licenses, 207, 472.  
 Assessment on Runs in Monaro District, 235.  
 Revenue, District of Inverell, 15, 122, 344, 363.  
 Do Districts of Warrialda, Bingera, and Moree, 102.  
 Local Land Board and Survey Office, Wagga Wagga, 28, 261.  
 Local Land Boards, 439.  
 Dubbo Land Office, 31.  
 Clarence River Local Land Board, 55.  
 Report Lismore Land Board on working of Act, 83.  
 Land Board at Casino, 497.  
 Expenses and work of Local Land Boards, 96.  
 Local Land Board, Inverell, 376.  
 Local Land Board Grafton, 376.  
 Land Court, Richmond River, 83.  
 Burrabogie Run, 84.  
 Reserves in Eastern and Central Districts, 307.  
 Resumed Area of Western Division, 189.  
 Conditional Purchases, Yarralumla, 154.  
 Do Richmond River District, 126, 207.  
 Do Denis Morrissey's, 189.  
 William Skene's Prelease at Conargo, 143.  
 Millgate v. the Hon. John Smith, 149, 272.  
 Purchase of, Captain's Flat, 154.  
 Sale at Cheeseman's Creek and Cargo, 218.  
 Sale, Bingera, 235.  
 Reserves, Bulga Road, 251.

## Q

## QUESTIONS—(continued):—

- CROWN LANDS, &c.**—(continued):—  
 Crown Lessees, refund of Rents to, 256, 360.  
 Forfeited Conditional Purchases re-selected, 256, 290.  
 Temporary Common, Albury, sale of lands, 261.  
 Maps missing from the Survey Office, 261.  
 Land adjoining Racecourse at Cargo, 262.  
 Planting Trees on Forest Reserves, 270.  
 Reserves made in 1886 and 1887, 284.  
 Payment of Interest and Instalments in various Land Districts, 280, 290.  
 Ringbarking, 290.  
 Application of Mr. Thomas Brown, of Garra, near Molong, 313.  
 David Pollack's selection of Forfeited Conditional Purchase, Nangus, 318.  
 Runs forfeited since passing of Land Act of 1884, 340.  
 Land Revenue, district of Inverell, 344.  
 Rents from, Balranald, Wentworth, and Bourke, 347.  
 Land for sale at Molong, 348.  
 Reserve Maloga, 364.  
 O'Riel and Patterson, application for land at Dubbo, 376.  
 Application of John Brown for land at Garra, 377.  
 Belltrees Station, Selections made on, 384.  
 Conditional Purchases, Land Office, Molong, 395.  
 Mrs. O'Dwyer's Selection at Burrowa, 399, 401.  
 Bates's Selections, on Pullawing Station, Gunnedah, 401.  
 Pastoral Rents Eradication of Prickly-Pear, 403.  
 Mr. F. G. A. Trollope, 406.  
 Forfeited Selection of John Harrison, of Lismore, 431.  
 Mortgages of Pastoral and Homestead Leases, 441.  
 Lands Office, Albury, 419.  
 Statistics, 461.  
 Pastoral Holdings on Lines of Railway. Trial Surveys, 461.  
 Pastoral Holdings, Eastern Division, 483.  
 Conditional Purchases made by Mr. and Mrs. Poole and the Misses Parnell, 517.  
 Mr. G. S. Ridley, 522.  
 Forfeited Conditional Purchases, Coonabarabran, 545.  
 Land Alienated in Forbes District, 558.  
 Conditional Purchases taken up in Parkes and Molong, 577.  
 Mr. Park, Chief Commissioner at Hay, 578.  
 Lease of Protestant Hall, Dubbo, for Lands Office, 590.  
 Runs held by the Messrs. White in the Upper Hunter Electorate, 591.  
 Moree Land Board, 592.  
 Condobolin Land Board, 592.  
 Quan's Selection, North Arm Tweed River, 605.  
 Refund to Conditional Leaseholders, 607.  
 Extension of Lands Office, 633.
- CROWN LANDS BILL (No. 2)**:—Compensation for Improvements, 364.
- CROWN LANDS ACT OF 1884**:—  
 Land exchanged under 75 sec., 405.  
 Fencing Clauses, 528.  
 Rents, 542 (?).  
 Conditional Leases under 52nd clause, 542.  
 Extension of time to Pastoral Lessees, 556.  
 Permits to mine for Silver and other Minerals, 564.  
 Crown Tenants Appeals, 564.
- CROWN LESSEES (See "CROWN LANDS")**
- CROYDON**:—  
 Railway Station, 106.  
 Park, 356.
- CUDAL**:—Road to Davy's Plains, *via* Tapp's, 81, 280.
- CUMBERLAND DISEASE**:—M. Pasteur's Investigations, 460.
- CUMNOCK**:—Public School, 395.
- CUNNINGHAM'S GRANT, CIRCULAR QUAY**:—Payment of Quit Rent on, 184.
- CURRAN**:—Dismissal of, from Telegraph Department, 431.
- CUSTOMS**:—  
 Duties on wines, spirits, and beers, 31.  
 Duties collected at towns on River Darling, 38.  
 Appointment of the Treasurer's son-in-law to, 75.  
 Reduction in Staff since abolition of *ad valorem* duties, 110.  
 Position and promotion of Mr. Powell, jun., 143.  
 Imperial Copyright Statute, 173.  
 New Zealand Import Duty on Grapes, 240.  
 Duties on Butter, Bacon, Cheese, and Timber, 307.  
 Duty on Timber, 347.  
 Kerosene, Oil, &c., in Bonded Warehouses, 491.  
 Duties, 581, 611.  
 Imports and Exports between South Australia and New South Wales, 582.
- CUT WOOD**:—Railway rates on, 399.
- CUTCLIFFE, MR. CHARLES (See "ADMINISTRATION OF JUSTICE")**

## QUESTIONS—(continued):—

- CYCLING**:—On Sundays at Lithgow, 478.
- DALGLISH, MR. DISTRICT-SURVEYOR**:—Leave of absence, 352.
- DAMS AND TANKS**:—Eastern and Western Districts, 461.
- DARLING HARBOUR**:—  
 Storage of meat at, 75.  
 Depôt for Farm Produce, 102, 140, 191, 240, 271.  
 Farm Produce received at, 127, 217.  
 Railway Sheds, 144.  
 Government Meat Market, 285.  
 Farm Produce Market, 399.  
 Cartage of Wool, Produce, &c., 546.
- DARLING POINT**:—Drainage from, 127.
- DARLING RIVER**:—  
 Customs Duties collected at towns on, 38.  
 Bridge over, at Wilcannia, 311.
- DARLING-STREET WHARF (See "TRAMWAYS")**
- DAVY'S PLAINS**:—Road, Cudal to, *via* Tapp's, 81, 280.
- DAWES POINT**:—Purchase of land adjoining, by the Government, 56.
- DEAN, THOMAS**:—Summoned under Public Instruction Act, 61.
- DEATHS**:—While under influence of Chloroform, 270.
- DECREE (See "STEPHEN v. ERWIN")**
- DEDICATION**:—Nandi Flat, Castlereagh River, 340.
- DEFENCES (See also "MILITARY")**:—  
 Iron armour plate for works, 141, 205.  
 Storage of Gun-cotton, 143.  
 Of the Colony, 289, 367, 402.  
 Dr. Creed's Speech, 522.
- DELOHERY, MR.**:—Deputy Stipendiary Magistrate, 331.
- DEMURRAGE**:—Charges for, 564.
- DENILQUIN**:—Mr. Scott, Police Magistrate, at, 173.
- DEPOSITS (See "SAVINGS BANKS")**
- DEPÔT FOR FARM PRODUCE**:—Darling Harbour, 102, 140, 191, 240.
- DE SAILLY & Co.**:—Money due to under Rabbit Act, 557.
- DEVONSHIRE-STREET CEMETERY**:—  
 Closing of—Trustees for, 84.  
 Interments in, 101.
- DIAMOND DRILLS**:—  
 In use at Clarence Siding, 102, 190, 207.  
 Amounts due to the Mines Department for Augerand, 261.
- DIFFERENTIAL RATES (See "RAILWAYS")**
- DILGA CREEK**:—Bridge over, 62.
- DISEASED CATTLE**:—Sale of, 20.
- DISEASE IN STOCK**:—  
 District of Bourke, 81.  
 Throughout Colony, 262.
- DISTRICT COURTS**:—  
 Abolition of offices of Bailiffs, 45.  
 Precedence of Trials in, 133.
- DISTRICT ENGINEER'S STAFF AT BATHURST**:—Officers of, 271.
- DOBBOYD POINT**:—  
 Buoy fixed near, 134.  
 Lives lost at, 134.
- DOGS**:—  
 Number registered, 51.  
 Prosecutions for non-registration subsequent to registration, 190.  
 Registration of, Maitland, 191.
- DOMAIN**:—  
 Exclusion of the public from, 213.  
 Government, 369.
- DORN v. DORN**:—Case of, 436.
- DOUBLE BAY**:—Seaweed nuisance, 110.
- DRAINAGE**:—  
 From Darling Point, 127.  
 Borough of Alexandria, 412.  
 Western Suburbs, 546, 634.  
 Marrickville, 633.
- DREDGING**:—  
 In front of Mr. Ellis's property at Pymont, 111, 126.  
 Dredge for Shellharbour, 195.  
 Dredge for Tweed River, 276, 575.
- DRINK INQUIRY COMMISSION**:—Second and Final Report, 460.
- DRUITT TOWN**:—Tramway from Ashfield, 57.
- DRUMMOYNE**:—Leasing of wharf, 173, 190.
- DUBBO**:—  
 Land Office, 31.  
 Railway to Bourke, 420.  
 Engine-sheds and changing-places at, 503.  
 Protestant Hall, 590.
- DUCK RIVER (See "BRIDGES")**
- DULWICH HILL**:—Tramway, Marrickville to, 134, 633.
- DUPLICATION OF LINE (See "RAILWAYS")**
- DUTIES (See "CUSTOMS")**

## Q

## QUESTIONS—(continued):—

- DUXFORD ESTATE, GLENMORE ROAD:—Applications for licenses for public-houses, 407.
- DYNAMITE:—Use of, to destroy Fish, 447.
- EASTER ENCAMPMENT (See "MILITARY," also "VOLUNTEERS")
- EASTERN SUBURBS:—  
Court-house for, 96, 168.  
Sewerage of, 16, 164.
- EDUCATION:—  
Case of Thomas Dean, 61.  
Compulsory Clauses of Public Instruction Act, 73.  
School Attendance Officers, gratuities to, 74.  
Candidates for employment in Provisional Schools, 95.  
Public School, Arncliffe, 134.  
Do Tibooburra, 177.  
Do Cumnock, 395.  
Sickness in Public Schools, 214.  
Pooncarie School, 317.  
Examination Fees, University of Sydney, 347.  
Milparinka, Public School at, 364.  
Public Schools, Assistant Teachers, 388.  
Prosecutions under Public Instruction Act, 406, 435.  
Public School Fees, 407.  
Veterinary School, 395.  
Board of Technical, 423, 503, 577, 606 (?), 607, 630, 631.  
Technical, 428, 552, 577, 606, 619, 630, 631.  
New School, Pitt Row, Parramatta, Master of, 423.  
Resumption of Land, High School, Elizabeth-street, Public School, Castlereagh-street, 424.  
Public, 431.  
Miss Sutherland, Public School, Cooma, 436.  
Rock Flat Public School, 437.  
Training School, in connection with Department, 484.  
Fuel in Schools, 523.  
Mr. Cookson, Schoolmaster at Seven Hills, 528.  
Department of Engineering, Sydney University, 497.  
Church and School Lands, 313, 377, 557.  
Schools near Railway Line to Condobolin, 558.  
Public Instruction Act, cleaning Schools, 572.  
Training Institution for Teachers, 583.  
Polytechnic College, 584.  
Public School accommodation, Borough of Alexandria, 591.  
Complaint of Mr. Joseph Bolton against Mr. W. H. Margil, 607.  
Officers in Department over age of sixty years, 633.
- ELECTORAL:—  
Introduction of Bill limiting number of Members, 33.  
Revenue derived from the Namoi Electorate, 235, 363.  
Rolls for 1887—8, 251.  
Rolls, 435, 436, 441.
- ELECTRIC (See also "TORPEDO," also "TELEGRAPHS"):—  
Light in Legislative Assembly Chamber, 32, 39, 68.  
Motors for Tramways, 56.  
"Gulcher" Light Apparatus, 74, 106, 272, 305, 373.  
Armoured Cable, 87.  
Light Apparatus, 518, 584.  
Lighting Macquarie Light-house, 518, 632.
- ELLIS, MR. J. C., M.P.:—Dredging in front of property of, Pyrmont, 111, 126.
- ENNAVILLE:—Railway rates on merchandise, 394.
- EMPLOYEES:—  
(See also "RAILWAYS," also "TRAMWAYS," also "TELEGRAPHS")  
Re-employment of Dismissed Government, 523.
- ENDOWMENT:—  
*Pro rata* to contributions from non-resident ratepayers, in Municipalities, 173.  
Schools of Arts and Mechanics' Institutes, 534.  
On contributions for Municipal purposes, 477.  
To Municipalities, 570, 634.
- ENGAGED COMPARTMENTS (See "RAILWAYS")
- ENGINEER:—For Railway Trial Surveys, 291.
- ENGINEERING DEPARTMENT:—University of Sydney, 497.
- ENGINES (See "RAILWAYS")
- ENTRANCE TO RICHMOND RIVER:—Improvement of, 276.
- ERWIN, STEPHEN, v.:—Decree, 332, 511.
- ESKBANK:—Station-master, 450.
- ESTIMATES, THE:—Consideration of, 369, 388, 394.
- EUGOWRA:—  
Road to Forbes, 57.  
Bridge over Creek, 118.  
Travelling stock reserve on Canowindra Road, 179.
- EUBOWIE:—Water Supply for, 80.
- EVANS'S COMBINATION TRUCK:—Purchase of patent by the Government, 27, 32, 34, 39, 63.
- EVELEIGH (See "RAILWAYS")
- EXAMINATION FEES (See "UNIVERSITY OF SYDNEY")
- EXAMINERS OF TITLES:—Office hours and leave of absence, 63, 333.

## QUESTIONS—(continued):—

- EXHIBITION:—  
Adelaide Jubilee, 94, 133, 134, 190, 262.  
Indian and Colonial, 126.  
Melbourne, 372, 415.  
Paris, 581.
- EXHIBITION CONTESTS:—Scenes at, 256.
- EXPENDITURE (See also "FINANCE")  
Of Public Money in Sydney and Country Districts, 7.  
On local and national works, The Hastings and Manning Electorate, 101.  
Authorized and supplementary for 1887, 405.
- EXPORTS (See "CUSTOMS")
- FARES AND FREIGHT (See "RAILWAYS")
- FARM PRODUCE:—  
Depôt for, Darling Harbour, 102, 140, 191, 240, 271.  
Received by Railway at Darling Harbour, 127, 217.  
Market at Darling Harbour, 399.
- FARMS:—Model, 48, 63, 267, 323.
- FEES (See "ATTORNEY-GENERAL," also "ARMSTRONG, MR. JOHN, BARRISTER-AT-LAW," also "UNIVERSITY OF SYDNEY," also "CLERKS OF PETTY SESSIONS")
- FEDERAL REVIEW (See "MILITARY")
- FENCING (See "CROWN LANDS ACTS OF 1884")
- FERRIES:—  
Leasing of, at Menindie, 154.  
Government, 428, 432.
- FIELD OF MARS:—Tramway, 240, 266, 343, 598.
- FINANCE:—Consolidated Revenues of various countries, 109.  
Public Works Loan Act of 1884, 518, 528.  
The Estimates, 369, 388, 394.  
Public Revenue and Expenditure, 373, 377, 385, 571.  
Public Loans, 393, 396.  
Railway Loans, 396.  
Public Accounts, 396.  
Authorized and Supplementary Expenditure for 1887, 405.  
Financial Statement, 414.  
Assistant Examiner of Accounts, 473.  
Consolidated Revenue Fund, 590.  
Treasurer's Advance Account, 590.
- FINCHAM, MR.:—Promotion of, in Central Police Office, 223.
- FIRE:—Careless use of, 331.
- FIRE BRIGADES ACT:—Contribution of Insurance Companies towards working, 84.
- FIREWORKS:—Exclusion of the public from the Domain on occasion of, 213.
- FISH:—Use of dynamite to destroy, 447.
- FISHERIES ("See also "NET-FISHING"):—  
Introduction of Bill to amend Act, 110.  
Abolition of Board and reorganization of Department, 206.
- FORBES:—  
Railway line to, 521, 611.  
Road to Eugowra, 57.  
Lands alienated in District of, 558.  
Municipal Revenue, 559.  
Public Buildings in, 577.  
Publican's Licenses, 582.  
Deposits, &c., in Savings Bank, 582.  
Public Money spent in, 582.  
Horses and cattle in District, 582.  
Miners' Rights and Business Licenses in District, 583.  
Land and Revenue Statistics, 590.  
Municipal Chambers at, 611.
- FORESHORES:—Waverley and Bondi, 134.
- FORESTS:—  
Destruction of timber on Burrawong Run, 52.  
Planting trees on reserves, 270.  
Reserve, Terania, 307, 458.
- FOSBERY, MR.:—Seat on Transit Commission, 457.
- FOSKETT, MR.:—Stamp Office, 214, 299.
- FREDERICK, CAPTAIN:—Coast-going Certificate of, 81, 97, 133.
- FREE PASSES:—  
Permanent, 16, 453.  
To Unemployed, 20.  
To Officials of Railway Department, 68, 411.  
To Major Taunton, 121.  
To Major Staunton, 134.  
To Mr. Clibborn, 385, 401, 440.  
To Wesleyan Ministers, 457.  
To Salvation Army Officer, 461.
- FRIENDLY SOCIETIES ACT:—Annual Returns under, 279.
- FRIEZE-WORK:—  
For telephonic system in George-street, 7, 265.  
Cable for, 46, 127, 265, 453, 474, 490, 540.
- FUEL IN SCHOOLS:—Supply of, 523.
- FUNDS (See "TRUST FUNDS")

## Q

## QUESTIONS—(continued):—

- FURNITURE:—Court-house, Narrabri, 339.  
 GALATHERA AND BOGGY CREEK TANK:—Reserve at, 415.  
 GALVIN, MR.:—Refusal of Cowra Bench to grant license to, 396.  
 GAOLS:—  
   Bourke, 31.  
   Bombala, 256.  
   New, at Bathurst, 271.  
   Casino, Prison Labour, 490.  
 GARDEN ISLAND:—Imperial buildings on, 127.  
 GARRETT & GREVILLE, MESSRS.:—Mineral Leases held by, 498.  
 GARRETT, MR., M.P.:—Mineral lands held by, 540, 575, 592.  
 GARSED, MR. JOHN:—Letters addressed to Attorney-General, 63.  
 GASLIGHT COMPANY:—Incorporation of Australian, 106.  
 GENERAL POST OFFICE (See "POSTAL"):—  
   Formation of street north of, 396.  
 GERMANS:—In Samoa, 20.  
 GERMANTON:—Water supply for, 395.  
 GERSBECH, JOSEPH (See "ROADS")  
 GIBSON, MR. R.:—Tender for castings for Harbours and Rivers Department, Newcastle, 291, 307.  
 GILES, T. B.:—Mitigation of sentence passed on, 227.  
 GILES, MR.:—Police Magistrate Bombala, 556, 578.  
 GLADESVILLE:—  
   Post-office accommodation, 121.  
   Lock-up and Quarters at, 267.  
   Telegraph Office, 267.  
   Mr. Thomas, formerly inmate of Asylum, 402, 473.  
   Alignment of streets at, 598.  
 GLEBE ISLAND ABATTOIRS:—  
   Removal of, 7, 14.  
   Leasing of, 206.  
   Condition and management of, 213.  
   Mr. Read, 333.  
 GLEN INNES:—  
   Railway rates on merchandise, 394.  
   Postmaster at, 612.  
 GODDARD, MRS. M., OR BAKER:—Police proceedings against, 447.  
 GOLD:—  
   Prospecting Vote for, 84, 189, 327.  
   Mining and Mineral Leases, 105.  
   Fields—Wardens, 227, 245.  
 GONGOLGAN:—Road to Byrock, 183, 279.  
 GOODS TRAFFIC (See "RAILWAYS")  
 GORE'S BAY:—Island at entrance of, 578.  
 GOULBURN:—  
   Site for Church of St. Saviour, 87.  
   Railway to Crookwell, 88, 450.  
   Duplication of Railway Line to Cooma Line Junction, 317.  
 GOVERNMENT (See also "TRAMWAYS")  
   Land purchased by in Parramatta, 8.  
   Purchase of A.S.N. Co.'s Wharf and land adjoining by, 8, 56.  
   Rumoured purchase of Russell's Wharf, and A.S.N. Co.'s Works, Pyrmont, by, 8.  
   Property resumed in Macquarie-street and Domain, 19.  
   Land purchased by, at Macdonaldtown, 32.  
   Steam launches, 143.  
   Land sold to Mr. R. Cousins, 184.  
   Purchase of Statuary, 227, 592.  
   Railway Policy, 257, 284, 384.  
   Meat Market, 285.  
   Domain, 369.  
   Ferries, 428, 432.  
   Property, Municipal Rates, 473.  
   Printing Office, 483, 583, 612.  
   Re-employment of dismissed employes, 523.  
 GOVERNMENT ASYLUMS:—Reports as to management of, 7.  
 GOVERNMENT GAZETTE:—Supply to Schools of Arts, 245.  
 GRAIN:—Cost of carrying by Northern Railway, 293.  
 GRAFTON:—  
   Local Land Board, 376.  
   Post and Telegraph Master at, 473.  
 GRANTS:—(See "MUNICIPAL," also "ROADS")  
 GRANVILLE:—  
   Postal accommodation, 102.  
   Duplication of line from Penrith, 323.  
   Duplication of line from Liverpool, 331.  
   Delay of Mail Train, 612.  
 GRAPES:—  
   New Zealand Import Duty, 240, 251.  
   Importation of, into Victoria, 256.  
   Board of Inquiry into Phylloxera, 490.  
   Phylloxera in County of Cumberland, 582.

## QUESTIONS—(continued):—

- GRAVEL:—Railway haulage rate from Penrith, 68.  
 "GULCHER" ELECTRIC LIGHT APPARATUS:—Purchase of, 74, 106, 272, 305, 373.  
 GREVILLE & GARRETT:—Mineral Leases held by, 498.  
 GUARDS (See "TRAMWAYS")  
 GUN-COTTON:—Storage of, 143.  
 GUNNEDAH (See "ROADS")  
 GUNPOWDER:—Establishment of a manufactory, 14.  
 HALLOBAN, CASE OF JOHN:—At Sydney Hospital, 257.  
 HAMLET, MR.:—Government Analyst, 34.  
 HANSAED:—  
   Reporting Staff, 240.  
   Supply of, to Schools of Arts, 245.  
 HARBOURS AND RIVERS DEPARTMENT:—  
   Castings for Newcastle, 291, 307.  
   Pay Sheets taken from, 495.  
 HARRIS PARK:—Railway platform, 105  
 HARRISON, JOHN:—Forfeited selection at Lismore, 431.  
 HASTINGS AND MANNING ELECTORATE:—Expenditure on local and national works in, 101.  
 HAWKESBURY RIVER:—  
   Net-fishing, 262, 314.  
   Railway Bridge, 284, 293, 307, 319, 331, 337, 355, 359, 533, 590.  
   Do Medical attendance to employes at, 414.  
 HAWTHORNE, MR. SAMUEL:—Appointment of, 283.  
 HAY:—Mr. Park, Chief Commissioner, Crown Lands at, 578.  
 HEALTH OFFICER:—Watson's Bay, 448.  
 HEALY, PRISONER (See "ADMINISTRATION OF JUSTICE")  
 HELZINGER, MR. A.:—Suspension of in Railway Department, 32.  
 HESSIAN FLY:—Introduction of, 415.  
 HILLSBOROUGH (See "BRIDGES")  
 HISTORY, OFFICIAL, OF NEW SOUTH WALES:—Publication of new edition, 191, 523, 534.  
 HOLIDAYS:—  
   In General Post Office, 272, 356, 489.  
   For classified officers of Railway Department, 402.  
 HOLT, J. J.:—Appointment to the Railway Department, 423.  
 HOLT, PRISONER:—Liberation of, 360.  
 HOIT-SUTHERLAND ESTATE:—Work of unemployed on, 150.  
 HOMEBUSH (See also "RAILWAYS")  
   Railway to Waratah, 95, 400.  
   Woy Woy platform, railway to Waratah, 407.  
 HOMESTEAD LEASES (See "CROWN LANDS")  
 HOOPER'S TORPEDO CORPS:—Storage of, 87.  
 HORDERN, MR. ANTHONY:—Typhoid fever at establishment of, 126.  
 HORDERN'S:—Advertising Placards on Tramways, 356.  
 HORNSBY (See "RAILWAYS")  
 HORSES (See also "TELEGRAPHS")  
   Cattle, &c., in Forbes and Molong Districts, 583.  
 HOSPITAL (See "SYDNEY HOSPITAL")  
 HOUR OF MEETING:—For sittings of Assembly, 207.  
 HUDSON BROS.:—Contracts given to, without competition, 69.  
 HUNTER RIVER (See "BRIDGES")  
 HURSTVILLE:—Passenger traffic at Railway Station, 111.  
 HUSBAND, JAMES H.:—Claim of, 155.  
 ILLAWARRA (See "RAILWAYS")  
 IMMIGRATION:—Mr. G. F. Wise and Mr. F. B. Treatt, 534.  
 IMPERIAL INSTITUTE:—Contribution from Australian Colonies, 69.  
 IMPORT DUTY (See also "CUSTOMS"):—  
   On grapes, New Zealand, 240.  
 IMPORTATION OF SPIRITS:—Revenue from, 368.  
 IMPROVEMENTS (See "CLARENCE RIVER;" also "CROWN LANDS BILL, No. 2;" also "CIRCULAR QUAY.")  
 INDIAN AND COLONIAL EXHIBITION:—Expenditure on, 126.  
 INFANTRY (See "MOUNTED INFANTRY")  
 INGLIS, THE HONORABLE JAMES:—Sleeping-car for accommodation of, 402.  
 INSANE (See "ASYLUMS")  
 INSURANCE COMPANIES:—Contribution of, to Fire Brigades Act, 84.  
 INTEREST AND INSTALMENTS (See "CROWN LANDS")  
 INTOXICATING DRINK INQUIRY COMMISSION:—Second and Final Report, 460.  
 INVERELL:—  
   Mails to, 7.  
   Land Revenue, &c., District of, 15, 122, 344, 363.  
   Extension of Railway to, 195, 199.  
   Reserve Corps, 307.  
   Licensing Board, 371.  
   Local Land Board, 376.  
   Railway Line to, 557.

## QUESTIONS—(continued):—

## IRON :—

- Testing of, used for Bridges, Roads Department, 62.
- Do Colonial, 167.
- Telegraph Poles, 62, 127, 340.
- Armour Plate for defence works, 141, 205.
- Supply of ironwork for bridges, 213.
- Bridges, 432.

## IRON COVE BRIDGE :—

- Wire netting on side lattice, 21.
- Return respecting, 424.
- Protection from Road Traffic, 460.

## ISLAND :—At entrance of Gore's Bay, 578.

## JARDINE SPAR TORPEDO :—Papers respecting, 105, 114.

## JERVIS BAY :—

- Railway from Kiama, 251.
- Coaling and Shipping Port, Lighthouse, 324.

## JENOLAN CAVES :—Railway, Tarana to, 56, 167.

## JETTY AT WATSON'S BAY :—Lease of, 564.

## JOADJA :—Mining Reserve, 190, 563.

## JOHNSTON'S BAY :—Old vessels laid up, 207.

## JOHNSTON'S ESTATE :—Street to Railway Station, Peter-sham, 536.

## JUBILEE EXHIBITION (See "EXHIBITION")

## JUNEE :—Court-house, 184.

## JURORS :—District Court, Cooma, 68.

## JURY LIST :—Alteration in System of Summoning, &amp;c., 312.

JUSTICES OF THE PEACE :—*Supersedes* to Bankrupt, 319.

## KELSO :—Lock-up, 69.

## KEROSENE OIL :—In bonded warehouses, 491.

## KIAMA :—Railway to Jervis Bay, 251.

## KIDMAN, MESSRS. :—Payments to, under contracts, 272.

## KINCHEGA :—Bridge on road to Menindie, 154.

## KINGSBURY H. H. &amp; Co. :—Telegraph material supplied by, 46, 127, 251.

## KOGARAH :—Sans Souci tramway, 56.

## KOONDOOK :—Road to Moulamein, 57, 180, 184, 371.

## KURNELL :—Land at, Botany Bay, 267.

## LABOUR BOARD :—

- Particulars of, 33.
- Expenditure of, &c., 125.

## LAKE ALBERT :—Proposed works at, 618.

## LAND (See also "CROWN LANDS") :—

- Purchase of, in Parramatta, 8.
- Resumption of, near Bradley's Head, 14.
- Purchase of, adjoining Dawes Point, 56.
- Purchase of, Macdonaldtown, 32.
- Purchase of, on Pennant Hills Road, 491.
- Resumed for railway and tramway purposes, 74, 265, 271.
- Sold to Mr. R. Cousins, 184.
- Resumed, belonging to the Messrs. Ryrie, 217.
- Kurnell, Botany Bay, 267.
- Payment of interest and instalments in various districts, 280.
- For sale, Parish of Molong, 348.
- Junction of Illawarra and Great Southern Railway, 368.
- Corner of Oxford and Elizabeth Streets, Paddington, 474.

## LAND BOARDS (See "CROWN LANDS")

## LANDS DEPARTMENT :—

## Senior Officers in, 13.

## Overtime Work, 270.

## LANDS OFFICE :—Extension of, 633.

## LANE FAMILY (See "TERALBA COAL-MINING RESERVE")

## LA PEROUSE :—

## Road near, 412.

## Aborigines at, 591.

## LAUNCHES :—Employment of Government, 143.

## LAWRENCE :—Court-house, 312.

## LEAVE OF ABSENCE :—

## Mr. District Court Judge Murray, 69.

## Mr. O'Malley Clarke, 299, 351.

## Mr. Yates, 351.

## Mr. Dalglish, District Surveyor, 352.

## LEESON, MR. :—Telegraph Department, 111, 126.

## LEICHHARDT :—

## Lock-up, 179.

## Court of Petty Sessions, 413.

## Tramway from Darling-street Wharf, Balmain, 543.

## LEONARD, MR. :—Road Contractor, 57.

## LESSEES (See "CROWN LANDS")

## LETTER-CARRIER (See "POSTAL")

## LEWISHAM :—

## Railway Station, 96, 105.

## Revenue received at Railway Station, 313.

## LICENSES (See "TIMBER")

## LICENSING ACT :—

## Introduction of Amending Bill, 21.

## William Spangenberg's Application for a Billiard License, 38 (2).

## Q

## QUESTIONS—(continued) :—

## LICENSING ACT (continued) :—

- Private Bars in Public Houses, 46.
- Violations of, 206.
- Opening public-houses on Christmas Day, 227.
- Accommodation in City Hotels, 306.
- Applications for licenses for public-houses, Duxford estate, Glenmore Road, 407.

## LICENSING :—

## Members of Benches acting as Magistrates, 69, 163.

## Board :—Inverell, 371.

## LIGHT-HORSE (See "MILITARY")

## LIGHTHOUSE :—Between Broken Bay and Newcastle, 93.

## LIGHTING :—

## Moama Bridge, 290, 364.

## Botany Road, 412.

## LISMORE :—

## Report from Land Board on working of Land Act, 83.

## Formation of Volunteer Force, 533.

## Case tried before Police Magistrate, 575.

## LIST (See "JURY LIST")

## LITRGOW :—Cycling on Sundays at, 478.

## LIVERPOOL :—

## Presbyterian Cemetery, 227, 235.

## Municipal Council, 319.

## Duplication of Line from Granville, 331.

## LOANS (See "FINANCE")

## LOCAL LAND BOARDS (See "CROWN LANDS")

## LOCAL OPTION :—Resolution carried in Assembly, 46, 153.

## LOCK-UP :—

## Moama, 63.

## Kelso, 69.

## Leichhardt, 179.

## Gladesville, 267.

## Parramatta North, 324.

## Ardeliffe, Rockdale, Kogarah, or Hurstville, 634.

## LOCOMOTIVE (See "RAILWAYS")

## LUCAS, MR. SURVEYOR :—Case of, 522.

## MABEL :—Steam Launch, 275.

## MACARTHUR, MR. :—Late Acting Police Magistrate at Corowa, 180.

## MACDONALDTOWN :—

## Land purchased at, 32.

## Revenue received at Railway Station, 313.

## MACKENZIE, MR. :—Examiner of Coal-fields, 7, 14, 20, 33 (2).

## MACLEAN :—

## Trustees for Recreation Grounds at, 121.

## Court-house, 312.

## MACQUARIE LIGHTHOUSE :—Electric-lighting, 518, 632.

## MAGISTRATES (See also "STIPENDIARY")

## Nominations for appointment, 8 (2), 21, 57.

## Members of Licensing Benches acting as, 69, 163.

## Young District, 341.

## MAIL CONTRACTS (See "POSTAL")

## MAIL GUARDS :—In mail-vans, 407.

## MAILS (See "POSTAL")

## MAIL TRAIN (See "RAILWAYS")

## MAINTENANCE MEN :—

## Roads Department, 206.

## Road, Boree to Parkes, 333.

## MAITLAND :—Registration of dogs in, 191.

## MALOGA :—Reserve at, 364.

## MANGROVE CREEK :—Bridges over, 149.

## MANLY :—

## Court of Petty Sessions, 88.

## Aquarium, 533.

## MANNING, MR. :—Coroner at Ryde, 270.

## MAPS :—Missing from the Survey Office, 261.

## MARGIL, MR. W. H. :—Complaint of Mr. Joseph Bolton, 607.

## MARINE BOARD :—

## Moama, 56, 183

## Captain Frederick, 81, 97, 133.

## Regulations, 414, 597, 632.

## Suspension of Master Mariner's Certificate, 541.

## MARINE :—Use of cast-iron propellers by steamers, 139.

## "MARIPOSA," s.s. (See "QUARANTINE")

## MARRICKVILLE :—

## Tramway to Dulwich Hill, 134

## Flooding of the Railway Embankment, Cook's River, 179.

## Billiard Licenses, District of, 270.

## Drainage of, 633.

## MARTINI-HENRY RIFLES :—Numbers held, issued, and in store, 459, 475, 489.

## MATHESON AND ARNHEIM, MESSRS. :—Tin lease of, Silver-ton, 142.

## M'SHARRY V. COMMISSIONER FOR RAILWAYS :—Arbitration Case, 37, 96, 319.

## MEASLES :—And typhoid fever, Alexandria and Waterloo, 111.

## Q

## QUESTIONS—(continued)—

- MEAT** :—  
Storage of, at Darling Harbour, 75.  
Delivery of unwholesome, for consumption, 213.  
Government Market, 285.
- MECHANICS' INSTITUTES** :—Endowments, 534.
- MEDALS** :—For Centennial Commissioners, 301.
- MEDICAL** :—Attendance to Employés at Hawkesbury Railway Bridge, 415.
- MEDICAL BILL** :—Introduction of, 39.
- MEDICAL PRACTITIONERS** :—Money due by Government to, 255.
- MELBOURNE EXHIBITION** :—  
Commissions, 372.  
Appointment of Mr. Oscar Meyer, as Superintendent, 415.  
Federal Review of Troops during, 546, 558.
- MEMBERS** (See "PARLIAMENT")
- MENINDIE** :—  
Mail Service between Silvertown and, 153.  
Ferry at, 154.  
Bridge on road to Kinchega, 154.  
Height above sea level, 163.
- MESSENGERS** (See "TELEGRAPHS")
- METROPOLITAN WATER AND SEWERAGE BOARD** :—  
Appointment of Mr. Reginald Bloxsome as Secretary to, 368.  
Water Rates charged by, 563, 575.  
Applications for position as Secretary to, 423.
- MEYER, MR. OSCAR** :—Appointment, Secretary to Melbourne Exhibition, 415.
- MICHELAGO** :—  
Opening of Railway to, 180.  
Bench of Magistrates, 613.
- MICROBES** (See "RABBIT PEST")
- MIDELTON, MR.** :—Appointment as Locomotive Engineer, 327, 477, 484.
- MILITARY** (See also "DEFENCES") :—  
Examinations for Officers, 57.  
Major Parrott's Report, 62.  
Storage of Hooper's Torpedo Core, 87.  
Armoured Electric Cable, 87.  
Jardine Spar Torpedo, 105, 141.  
Reserve Corps, 118.  
Free Pass to Major Taunton, 121.  
Torpedo Corps, 121.  
Stores returned from Suakim, 179.  
Promotion of Captain H. P. Airey to Brevet-Major, 189.  
Defences of the Colony, 289, 367, 402.  
Mounted Infantry, 306, 307.  
Country Reserve Corps, 307.  
Inverell Reserve Corps, 307.  
Rifle Clubs, 270, 299.  
Supernumeraries—Easter Encampment, 180, 199, 334, 359.  
Do Metropolitan and Country Reserves, 318.  
Do Payment of the Service, 318.  
Orderly Clerks, Brigade Office, 333.  
Establishment of Manufactory for Small-arms Ammunition, 414.  
Martini-Henry Rifles, 459, 475, 489.  
Volunteer Artillery, 541.  
Country Cavalry Corps, 497.  
Officers' Horses, Servants, and Railway Passes, 521.  
Dr. Creed's Speech on Defences of the Colony, 522.  
Federal Review of Troops during Melbourne Exhibition, 546, 558.  
Brigade Office Accounts, 576.
- MILLGATE v. HON. JOHN SMITH** :—Compliance with Order for Papers, 149, 272.
- MILLS & SHAND** (See "WATER SUPPLY")
- MILPARINKA** :—  
Telegraph line to, or Mount Browne, 177.  
Public School, 364.
- MINING** (See also "COLLIERIES") :—  
Applications for Mineral Leases, 207.  
Introduction of Bill, 7.  
Gold and Mineral Leases, 14, 105.  
Mineral Leases, Captain's Flat, 155, 280, 291, 367.  
Business Sites at Captain's Flat, 607.  
Department, 21, 33.  
Department—Police Magistrates appointed Wardens under, 227, 245.  
On Private Property Bill, 33, 377.  
Prospecting Vote of £15,000, 84, 189.  
Reservations for, Parish of Talbragar, 96.  
Diamond Drill in use at Clarence Siding, 102, 190, 207.  
Refractory ores, 118.  
Messrs. Matheson and Arnheim's tin lease, Silvertown, 142.  
Joadja Reserve, 190, 563.  
Assays made by Department, 276.

## QUESTIONS—(continued)—

- MINING** (continued) :—  
On Church and School Lands, 313.  
Silver-mining Boom, 341, 371.  
Ventilation of Mines, 368.  
Shares liable to forfeiture, 372.  
Application of Butcher and others for lease at Broken Hill, 377.  
Church and School Lands Bill, 377.  
Mr. Ridley—South Waratah Coal-mines, 377.  
Leases, Cobar District, 458.  
Mineral Leases, 471.  
Leases held by Messrs. Garrett & Greville, 498.  
Teralba Coal-mining Reserve, 498<sup>(2)</sup>, 503, 521, 617.  
Boring Operations, Clarence Siding, 498.  
Lands held by Mr. Garrett, Minister for Lands, 540, 575, 592.  
Permits to Mine for Silver and other Minerals, 564.  
Miner's Rights in Districts of Forbes, Parkes, and Molong, 583.
- MINER'S RIGHTS** (See "MINING.")
- MITTAGONG** :—Opening of Regent-street, 529.
- MOAMA** :—  
Wharf, 56, 183, 289.  
Marine Board, 56, 183.  
Lock-up, 63.  
Bridge at, 122, 290, 364.  
Aborigines at, 122.  
Police Buildings at, 143.  
Common, 164.  
Water Supply, 364.  
Commissioner for Affidavits, 367.
- MODEL FARMS** :—Establishment of, 48, 63, 267, 323.
- MOIRA FOREST RESERVE** :—Occupation by Aborigines, 122.
- MOLONG** :—  
Traffic on Railway Line, 27.  
Volunteer Corps, 280, 337.  
Land for Sale at, 348.  
Revenue taken at Land Office, 395.  
"Pleuro" at Bob's Creek, 414.  
Railway Extension to Wilcannia, *via* Parkes, 535.  
Railway from Orange, 535, 564, 577.  
Post and Telegraph Office, 559.  
Railway Goods Traffic, 559.  
Railway, 570, 590.  
Conditional Purchases taken up in, 577.  
Publicans' Licenses, 582.  
Deposits, &c., in Savings Bank at, 582.  
Horses, Cattle, &c., in District, 582.  
Miner's Rights and Business Licenses in District, 583.  
Railway Line to Parkes, 583, 617.  
Land and Revenue Statistics, 590.
- MONARO** :—Assessment on Runs in, 235.
- MONEY ORDER SYSTEM** :—Amalgamation with Postal and Telegraph, 340.
- MOONEY MOONEY CREEK** :—Snagging of, 262, 324.
- MOORE, MRS.** :—Inquiry into cause of death of, 74.
- MOORE PARK** :—Land taken from Sydney Common, 300.
- MOOREE** (See "CROWN LANDS")
- MORIARTY, MR. ALEXANDER** :—Removal of Pay-sheets from Harbours and Rivers Department, 495.
- MORRISSEY, DENIS** :—Conditional Purchases of, Coonabarabran, 189.
- MORTGAGES** (See "CROWN LANDS")
- MOSSMAN'S BAY** :—Reserve fronting, 406.
- MOULAMBIN** :—  
Road to Koondrook, 57, 180, 184, 371.  
Stock Route, 285.
- MOUNT BROWNE** :—Telegraph line to Milparinka or, 177.
- MOUNT MACQUARIE** :—Road to Carcoar, 34.
- MOUNT MANNING** (See "ROADS")
- MOUNT RENNIE CONVICTS** :—Case of, 28.
- MOUNTED INFANTRY** :—Conversion of Cavalry into, 306.
- MUDGE** :—Railway, Wallerawang to, 79, 395, 535, 564.
- MULLET CREEK** :—Embankments, 533.
- MULTIPLE CABLE** (See "TELEPHONE")
- MULWALA** :—Bridge over Murray River at, 27, 275.
- MUNICIPAL** :—  
Roads through Municipalities, 62, 504.  
Endowment *pro rata* for contributions from non-resident ratepayers, 173.  
Application of Camperdown Council to borrow, 189, 205.  
Liverpool Council, 319.  
Drainage—Borough of Alexandria, 412.  
Number of Municipalities in Colony, 415.  
Endowment on Contributions for Municipal purposes, 477.  
Rates on Government Property, 473.  
Special Grants to, 495, 511.  
Revenue, Parkes and Forbes, 559.  
Endowment to Municipalities, 570, 634.  
Chambers at Forbes and Parkes, 611.  
Municipality at Smithfield, 612.

## Q

## QUESTIONS—(continued)—:

- MUNRO DRINKING FOUNTAIN :—Erection of, at Singleton, 448.
- MURGA :—Road to Toogong, 27.
- MURRAY, MR. DISTRICT COURT JUDGE :—Leave of Absence to, 69.
- MURRAY RIVER :—  
Control of the Waters of, 28.  
Bridge over, at Mulwala, 27, 275.  
Bridge over Upper, 34, 275, 301.  
Bridge over, at Moama, 122.  
Aboriginals, 285.
- MURRUMBURRAH :—Clerk of Petty Sessions at, 436.
- MUSWELLBROOK :—  
Abolition of Court of Quarter Sessions at, 218.  
Railway to Cassilis, 556, 559.
- NAGLE MICHAEL :—Dismissal of, as Warder, Parramatta Lunatic Asylum, 21.
- NAME OF COLONY :—Cost incidental on proposed change of, 184.
- NAMOI :—Revenue from Electorate, 235, 363.
- NANDI FLAT, CASTLEREAGH RIVER :—Dedication of, 340.
- NANGUS (See "CROWN LANDS")
- NARANDERA :—Bridge at, 518.
- NARRABRI :—  
Road to Walgett, 39.  
Railway to Walgett, 39, 150.  
Railway Station, 163, 227, 284, 340.  
Furniture for Court-house, 339.  
Racecourse, 352.
- NARRAMINE :—Road to The Bogan, 51, 471.
- NATIONAL PARK :—William Ross, late Overseer, 51.
- NAVAL BRIGADE :—Supply of boats for, 110.
- NAVAL HOME :—Site for, 94.
- NAVIGATION ACT :—Introduction of amending Bill, 21.
- NAVIGATION :—Of Richmond and Tweed Rivers, 291.
- NEILD, MR. J. C., M.P. :—Executive Commissioner, Adelaide Exhibition, 94, 134, 190, 262, 495.
- NEPEAN WATER SUPPLY (See "WATER SUPPLY")
- NET-FISHING :—Hawkesbury River, 262, 314.
- NEWCASTLE (See also "RAILWAYS," also "HARBOURS AND RIVERS DEPARTMENT, NEWCASTLE") :—  
Railway and Tramway Employés, 15.  
Water Supply, 571.
- NEWINGTON ASYLUM :—  
Letter from Ladies of Board of Enquiry, 240.  
Letter from Mr. McElhone, M.P., 290.  
Management of, 337.
- NEW ZEALAND :—Import duty on grapes, 240, 251.
- NEW SCHOOL, PITT ROW, PARRAMATTA (See "EDUCATION")
- NEW HEBRIDES, THE :—  
Monthly Mail Service, 557.
- NEW SOUTH WALES :—  
Official History of, 191, 523, 584.
- NORFOLK ISLAND :—  
Official connection of Mr. H. T. Wilkinson with, 172.  
Visiting Magistrate, 436.  
Offer of British Government to hand over to New South Wales, 569.
- NORTH COAST :—(See "RAILWAYS")
- NORTH HEAD :—Removal of Quarantine Station from, 240, 368, 364.
- NORTH SHORE :—  
Fares on Tramway, 75.  
Whaling Road, 125.  
Extension of Railway, 389.  
Employees' Cable Tramway, 407.  
Railway from Hornsby, 578.
- NORTHERN MAIL :—  
Delay of, 293 (?).  
Detention of train, 293.  
Saturday Train, 408.
- NORTHUMBERLAND :—Visit of Colonial Secretary to, 9.
- NOXIOUS WEEDS :—  
Destruction of, 280.  
Richmond River District, 533.
- NUISANCE :—  
Seaweed, at Botany, 32, 70, 333, 412.  
Do Double Bay, 110.
- NYNGAN :—Railway to Cobar, 215.
- OBERON :—Survey of Railway. *vid* Cox's River, 343.
- OCCUPATION LICENSES (See "CROWN LANDS")
- O'DWYER, MRS. (See "CROWN LANDS")
- OFFICERS :—District Engineer's Staff, Bathurst, 271.
- OFFICIAL HISTORY OF NEW SOUTH WALES :—Publication of new edition, 191, 523, 584.
- OPERATORS (See "TELEGRAPHS")
- ORANGE (See also "RAILWAYS") :—  
Telegraph Office, 323.  
Railway to Molong, 535, 564, 577.

## QUESTIONS—(continued)—:

- ORDERLY CLERKS (See "MILITARY")
- ORES :—Railway freight on Mineral, 399, 490.
- O'RIEL (See "CROWN LANDS")
- OVER-BRIDGE (See "RAILWAYS")
- OVER-TIME WORK :—In Lands Department, 270.
- OYSTERS :—  
Abolition of duty or royalty, 88, 94, 105, 142.  
Charge on Spat, 327.
- PACIFIC MAIL STEAMSHIP COMPANY :—  
Claim of, respecting San Francisco Mail Contract, 239, 319.
- PADDINGTON :—  
Telephone exchange for, 173.  
Rifle range, 450, 489.  
Land at corner of Oxford and Elizabeth Streets, 474.
- PAIN'S FIREWORKS :—Exclusion of the public from the Domain on occasion of, 213.
- PALMER'S ISLAND :—  
Postmaster at, 441.  
Stationmaster at, 453.
- PARKS, PUBLIC (See also "CENTENNIAL PARK") :—  
Subsidies to, 33.  
Electorate of Redfern, 239.  
Wee Waa, 272.  
Trustees for Pilliga, 339.  
Do Richmond, 351.  
Do Croydon, 356.  
And Recreation reserves—Endowed and handed over to Councils, 384.
- PARIS EXHIBITION :—  
Cost to Colony for representation at, 581.
- PARK MR. :—Chief Commissioner of Crown Lands, Hay, 578.
- PARKS :—  
Auburn Road Trust, 424.  
Arncliffe, 572.
- PARKES (See also "RAILWAYS") :—  
Municipal Revenue, 559.  
Conditional Purchases taken up in District of, 577.  
Public Buildings in, 577.  
Publicans Licenses, 582.  
Deposits, &c., in Savings Bank, 582.  
Public Money spent in, 582.  
Miners' Rights and Business Licenses, District of, 583.  
Railway Line from Molong, 583, 617.  
Municipal Chambers at, 611.
- PARLIAMENT :—  
Land resumed in Macquarie-street and Domain for new Houses, 19.  
Electric Light in Buildings, 32, 33, 68.  
Reporting Staff, 240.  
Payment of Members Bill, 256.
- PARLIAMENTARY COMMITTEE ON PUBLIC WORKS :—  
Gazetting of, 565.  
Appointment of Secretary to, 607.
- PARNELL, THE MISSES (See "CROWN LANDS")
- PARRAMATTA (See also "RAILWAYS") :—  
Purchase of Land by the Government, in, 8.  
Overbridge at Railway Station, 47.  
Purchase of frontage to River by Mr. W. Pritchard, 271.  
Deepening the River, 306, 634.  
North, Lock-up at, 324.  
Asylum, 337, 521.  
North, Site for Benevolent Asylum, 343.  
Duplication of Railway Line to Penrith, 360, 375 (?), 427, 477, 511.  
River Bridge, 424.  
Post and Telegraph Master at, 473.  
Delay of Mail Train, 612.  
Post Office at, 571.
- PARROTT, MAJOR :—Report of, on Military matters, 62.
- PASSES (See "RAILWAYS")
- PASTEUR, MONSIEUR (See "RABBIT PEST")
- PASTORAL (See "CROWN LANDS")
- PASTURES (See "STOCK AND PASTURES BILL")
- PATENT FEES :—Paid to each Attorney-General since Responsible Government, 110.
- PATTERSON (See "CROWN LANDS")
- PAYMENT OF MEMBERS :—  
Limiting number of Members, in view of, 33.  
Introduction of Bill during Session, 256.
- PAYMENT OF MILITARY SERVICE (See "MILITARY")
- PEARCE'S CORNER (See "RAILWAYS")
- PEAT'S FERRY :—  
Railway Accident, 74, 118, 265, 276, 632.  
Land resumed at, for Railway purposes, 271.
- PENNANT HILLS' ROAD :—Land purchased by Government on, 491.
- PENNY POSTAL SYSTEM (See "POSTAL")



## Q

## QUESTIONS—(continued):—

- PENRITH** :—  
 Duplication of Line from Granville, 323.  
 Duplication of Railway Line from Parramatta, 360, 375 (?), 427, 477, 511.  
 Sunday Trains for, 529.
- PERMANENT FREEHOLD LAND AND BUILDING SOCIETY** (See "SYDNEY PERMANENT FREEHOLD LAND AND BUILDING SOCIETY")
- PERSONS EMPLOYED BY SQUATTERS** :—Number of, 313.
- PERTH** :—Telegraphic communication with railway station, 196.
- PETERSHAM** :—  
 Railway accident, 190.  
 Street between Johnston's Estate and Railway Station, 536.
- "Phylloxera"** :—  
 Prevention of spread of, 155, 191.  
 Board of Inquiry, 490.  
 In County of Cumberland, 582.
- PILLIGA** :—  
 Post and Telegraph Office, 183.  
 Trustees for Park, 339.  
 Road from Coonamble, 339.  
 Common, 339.
- PITT-STREET SOUTH** :—Wood-paving, 408.
- PLANTING TREES** :—On Forest Reserves, 270.
- PLATFORMS** (See "RAILWAYS")
- "PLEURO"** :—Prevalence of, at Bob's Creek, Molong, 414.
- POLES** (See "TELEGRAPHS")
- POLLACK, MR. DAVID** :—Selection of Forfeited Conditional Purchase, Nangus, 318.
- POLICE** :—  
 Duties of, under Towns Police Act, 33.  
 Interference with Salvation Army, 33.  
 Buildings, Moama, 143.  
 Quarters, Wellington, 179.  
 Do Rylstone, 483.  
 Officers in Central Office, 223.  
 Suppression of Boxing Matches, 312.  
 Barracks, Corowa, 395.  
 Sub-Inspector Bell and Detective Tindall, 407, 428.  
 Senior Constable Wright, 440.  
 Cycling on Sundays.  
 Protection of Prisoners in Police Court Cells, 499.  
 Stafford, Ex-Sergeant William, 551.  
 Lock-up at Arncliffe, Rockdale, Kogarah, or Hurstville, 634.
- POLICE MAGISTRATES** :—  
 Mr. Macarthur, late Acting, Corowa, 180.  
 Appointed Wardens under Mining Act, 227, 245.  
 Parramatta, appointment of, 420.  
 Lithgow, 478.
- POLICE OFFICE CELLS** (See "POLICE")
- POLYTECHNIC COLLEGE** :—Establishment of, 584.
- POOL, MR. AND MRS.** (See "CROWN LANDS")
- POONCALIE** (See "EDUCATION")
- POOR OF SYDNEY** (See "CENTENARY OF THE COLONY")
- POSTAL** :—  
 Inverell Mails, 7.  
 Penny Postage System, 47, 181, 323, 334, 618.  
 Post and Telegraph Office, Tumberumba, 57.  
 Do. Cobargo, 96.  
 Do. Granville, 102.  
 Do. Gladesville, 121.  
 Do. Pilliga, 183.  
 Do. Bourke, 39, 215.  
 Do. Broken Hill, 266, 428.  
 Do. Stanmore, 276.  
 Do. Wollombi, 393.  
 Do. Clock for Redfern, 412.  
 Do. Bourke, 498.  
 Do. Molong and Condobolin, 559.  
 Do. Parramatta, 571.
- Mail Service between Menindie and Silverton, 153.  
 Transmission of bank pass books, 184.  
 Claim of Pacific Steamship Company respecting San Francisco Mail Contract, 239, 319.  
 Materials supplied by H. H. Kingsbury and Co., 251.  
 Holidays in General Post Office, 272, 356, 489, 556.  
 Delay in arrival and delivery of Northern Mails, 293 (?).  
 Letter-carrier for Prospect and Sherwood, 301, 388.  
 Clerks employed in Secretary's and Mail Branches of the General Post Office, 312.  
 Amalgamation of Postal, Money Order, and Telegraph Systems, 340.  
 Mail Guards in Mail Vans, 407.  
 Redfern Post Office—Supply of Stamps, 413.  
 Buildings rented for Post Offices, 424.  
 Postmaster at Palmer's Island, 441.  
 Post and Telegraph Masters, Parramatta, Grafton, Cootamundra, and Braidwood, 473.

## QUESTIONS—(continued):—

- POSTAL (continued)** :—  
 Monthly Mail Service to New Hebrides, 557.  
 Postmaster at Glen Innes, 612.
- POTT'S HILL** (See "WATER SUPPLY")
- POULTON, J. A. H.** :—Case of, 265, 377, 384.
- POWELL, MR., JUN.** :—Appointment and promotion in Customs Department, 143.
- PRICE, Mr. W.** :—Appointment of as J.P., 8.
- PRICKLY PEAR** :—Eradication of, 403.
- PRINTING OFFICE** (See "GOVERNMENT PRINTING OFFICE")
- PRISONERS** :—  
 In Bourke Gaol, 31.  
 Release of, Centenary Celebration, 164.  
 Protection of in Police Office Cells, 499.
- PRISON LABOR** :—  
 Casino Gaol, 490.
- PRITCHARD, MR. W.** :—Purchase of frontage on Parramatta River, 271.
- PRIVATE BARS** :—In Public Houses, 46.
- PRIVATE PROPERTY** :—Introduction of Bill providing for mining on, 33, 377.
- PRODUCE** (See "FARM PRODUCE;" also "RAILWAYS")
- PROBATIONERS** (See "TELEGRAPHS")
- PROPELLERS** :—Used by steamers, 139.
- PROSECUTIONS BEFORE JURIES** :—Final decision in, 139.
- PROSECUTIONS** :—Under Public Instruction Act, 406, 435.
- PROSPECT** :—  
 Letter-carrier for, 301, 388.  
 Reservoir, 432, 511, 564.  
 Water Supply Works, Messrs. Mills and Shand, 581.
- PROSPECTING VOTE** :—Disposal of £15,000, 84, 189, 327.
- PROTECTION OF PRISONERS** (See "POLICE")
- PROTESTANT HALL, DUBBO** :—Lease of for Lands Office, 584.
- PROVISIONAL SCHOOLS** (See "EDUCATION")
- PRUEN, REGINA v.** :—Depositions, &c., in case of, 8, 79.
- PUBLIC BUILDINGS** :—Forbes and Parkes, 577.
- PUBLIC HOUSES** (See "LICENSING ACT")
- PUBLIC INSTRUCTION ACT** (See "EDUCATION")
- PUBLIC MONEY** :—Spent in Forbes and Parkes, 582.
- PUBLIC OFFICIALS** :—Vouchers for moneys paid by, 251.
- PUBLIC WORKS ACT** :—  
 Gazetting of Parliamentary Committee, 565.  
 Appointment of Secretary to Parliamentary Committee, 607.
- PUBLIC WORKS DEPARTMENT** :—Recommendations for retrenchment in, 13.
- PUBLIC ACCOUNTS** (See "FINANCE")
- PUBLIC LOANS** (See "FINANCE")
- PUBLICANS LICENSES** :—Districts of Forbes, Parkes, and Molong, 582.
- PUBLIC SCHOOLS** (See "EDUCATION")
- PUBLIC WORKS LOAN ACT OF 1884** :—Amounts borrowed, spent, and balance under, 518, 528.
- PULLAMING RUN, GUNNDAH** :—Bates's Selections on, 401.
- PURNAMOOTA** :—Tramway, Silverton to Thackaringa and, 235.
- QUAN** :—Selection of on North arm, Tweed River, 605.
- QUARANTINE** :—Soiled linen landed from s.s. "Mariposa," 301.
- QUARANTINE STATION** :—  
 Removal of from North Head, 240, 368, 384.  
 Breaking of Quarantine by Officers from, 384.
- QUARTER SESSIONS** :—Bombala, 256.
- QUEANBEYAN** :—Pastoral and Agricultural Show-ground, 56.
- QUEENSLAND BORDER** :—  
 Break of Railway Gauge at, 15.  
 Railway from Tenterfield to, 15, 183.  
 Road from Tumbulgam, 523.
- QUIRINDI** (See "ROADS")
- QUIT RENT** :—  
 On Cunninghame's grant, Circular Quay, 184.  
 Returns showing, 475.
- QUODDING, MR.** :—Length of service of, 142.
- RABBIT ACT** :—Money due to Messrs. De Saily & Co., 557.
- RABBIT PEST** :—  
 Premium for destruction of, 14, 63.  
 Inventions for extermination of, 149.  
 Fencing between Bourke and Barrigun, 218.  
 Commission to inquire into mode of destruction of, 290.  
 Subsidy, Balranald, Wentworth, and Bourke, 347.  
 Conference for destruction of, 364, 372.  
 Introduction of Chicken Cholera, 396.  
 Secretary to Commission, 406.  
 M. Pasteur's investigations, 460.  
 Cost of buildings, Rodd Island, 460.
- RACECOURSES** :—  
 Telegraphic Communication between, 332, Narrabri, 352.

## QUESTIONS—(continued) :—

## RAILWAYS :—

- Department Engineer-in-Chief's, Construction Branch, 214.
- Locomotive engines, 95, 122, 205, 327.  
Do manufacture of, in Colony, 6, 47, 110, 144, 413, 405, 495.  
Do competitive test of, 47, 69, 122.
- Employés—Newcastle, 15.  
Do Drivers and Firemen, 275, 285.  
Do Bathurst Workshops, 290, 428.  
Do Increase of Wages, 262, 306 (?), 318, 334, 394, 402, 598, 619.  
Do and tramways, 441, 540.  
Do Existing Lines Branch, 457.  
Do services of unregistered Surgeon, 490.  
Do Pay to fettle's wives for minding gates, 571.
- Draftsmen dismissed from Office of Engineer-in-Chief, 15  
Do Services of Unregistered Surgeon, 490.
- Fares—Peat's Ferry, 271.  
Sub-way—Alt-street, Ashfield, 275.
- Illawarra—Loop-line to Wollongong, 276.  
Illawarra, 541.
- Hawkesbury River Bridge, 284, 293, 319, 331, 337, 355, 359, 533, 590.  
Do do Medical Attendance to Employés, 414.
- Trial Surveys, Engineer for, 291.
- Second-class carriages, 292.
- Sydney to Brisbane, through-tickets, 292.
- Northern Mail trains, 293, 408.
- Cost of carrying grain on Northern, 293.
- Ticket-collector Edward Coole, 293.
- Delays of trains between Sydney and Parramatta, 294.
- Supply of coals for Railway Department, Singleton, 299.
- Differential rates, 300, 313.
- Platforms, Harris Park and Wentworthville, 105.
- Tarana to Jenolan Caves, 56, 167.
- Policy of the Government, 57, 177, 251, 257, 284, 384.
- Refreshment Rooms, 61, 377.
- Trucks, 69.
- Land resumed for, 74.
- Brakes, 74, 388, 632.
- Kiama to Jervis Bay, 251.
- Resumption of land for, 265, 271.
- Platform at Eveleigh, 270.
- Designs for cattle trucks, 63.
- Traffic on Molong lines, 27.  
Do at Narrabri Station, 163, 227.
- M'Sharry v. Commissioner, 37, 96, 319.
- Hon. J. Smith v. Commissioner, 51, 80, 96, 102.
- Hon. S. Charles v. Commissioner, 101 (?), 110.
- Narrabri to Walgett, 39, 150.
- Haulage rate on blue metal or gravel from Emu Plains, 47, 68.
- Goods charges, Bourke and Byerock, 195.
- Station, Parramatta, Overbridge at, 47.  
Do Bathurst—Hay loading stage, 81.  
Do Lewisham, 96, 105.  
Do Croydon, 106.  
Do Hurstville, 111.  
Do Whittingham, 142.  
Do Narrabri, 163, 284, 340.  
Do Tarago, 368.  
Do Blayney, 332.  
Do Bathurst, Payment of Wages by Station-master, 394.  
Do Eveleigh, 412.  
Do Auburn, crossing at, 313.  
Do Ashfield, train arrangements, 344.  
Do Bowral, 472, 558.  
Do Sydney, cloak-room, 545.  
Do Albury Water Supply, 584.  
Do Rookwood, 607.  
Do Strathfield, 582.
- Payment of wages in Department, 20, 81.
- Suspension of Mr. A. Helzinger, 32.
- Fetlers, 32.
- Surveyor Nicholas P. Carver, 96.
- Alfred Braine, timber inspector, 125.
- And Tramways Time-tables, 15.
- Overbridge, Bathurst, 15.
- Break of Gauge on Queensland Border, 15.
- Tenterfield to Queensland Border (Wallangarra), 15, 183.
- Dubbo to Bourke, 420.
- Earnings and cost of working, 420.
- Appointment of Frederick Cavanaugh and J. J. Holt to Department, 428.
- Mrs. M. Goddard or Baker, 447.
- Trial Survey, Singleton, via Jerry's Plains, towards Cassilis, 448.
- Telegraph Probationers connected with, 448.

## Q

## QUESTIONS—(continued) :—

## RAILWAYS—(continued) :—

- Return Tickets issued in connection with Centennial Exhibition, 448.
- Pastoral holdings on lines of trial surveys, 461.
- St. Leonards to Pearce's Corner (Hornsby), 16.
- Pearce's Corner to Waters of Port Jackson, 84, 97, 402.
- Free Passes—Permanent, 16, 453.  
Do to Unemployed, 20.  
Do Officials of Department, 68, 411.  
Do Major Taunton, 121.  
Do Major Staunton, 134.  
Do Mr. Clibborn, 385, 401, 440.  
Do Wesleyan Ministers, 457.  
Do Salvation Army Officer, 461.
- Students at Technical College travelling on, 168.
- Evans's Combination Truck Patent, 27, 32, 34, 39, 63.
- Accident at Peat's Ferry, 74, 118, 265, 276, 632.  
Do Petersham, 190.
- Wallerawang to Mudgee, 79, 395.
- Beyond Cassilis, 79.
- Trial Survey, via Colo Valley, 80, 266, 319.
- Embankment, Bathurst, 81.
- Goulburn to Crookwell, 88, 450.  
Do Cooma, 125.
- Homebush to Waratah, 95.
- Illawarra, 109, 111, 541.
- Sleeping Cars, 118.
- Farm produce received at Darling Harbour, 127, 217.
- Produce Dépôt at Darling Harbour, 102, 140, 191, 240.
- Sheds, Darling Harbour, 144.
- Audit of Accounts, 143.
- Claim of Terry & Co. on Department, 164.
- Communication between officials and passengers on trains while in motion, 172.
- Extension to Circular Quay, 178.
- Bridge over Cook's River, 179.
- Opening to Michelago, 180.
- Extension to Inverell, 195, 199.
- Loop-line near Wollongong, 199.
- Nyngan to Cobar, 215.
- Land belonging to the Messrs. Ryrie resumed for purposes of, 217.
- Officers of District Engineers Staff at Bathurst, 271.
- Suburban Fares, 217.
- Sunday Traffic, 217.
- Officer in charge at Canley Vale Platform 313
- Lewisham, Macdonaldtown, and Stanmore, revenue received at, 313.
- Goulburn to Cooma Junction, Duplication of Line, 317.
- Time-table, delay in issue of, 319.
- Station-master, Eveleigh, 323.  
Do Eskbank, 450.
- Granville to Penrith, Duplication of Line, 323.
- Combination Trucks, 327.
- Locomotive Engineers—Mr. Scott and Mr. Midelton, 327, 477, 484.
- Granville to Liverpool, Duplication of Line, 331.
- Bega-Eden, 332.
- Complaints made against employé in Department, 332.
- Trains late in arrival, 334, 372.
- Survey of proposed, to Oberon, via Cox's River, 343.
- Special to Windsor, 360.
- Duplication of line between Parramatta and Penrith, 360, 375 (?), 427, 477, 511.
- Through tickets between Sydney and Melbourne, via Blayney, 363.
- Land at junction of Illawarra and Great Southern Railways, 368.
- Passenger traffic on Great Northern and North-Western, 372.
- Limited express, engaged compartments, 376.
- Rates of workmen's tools of trade, 376.
- Suburban, System of, 385.
- North Shore, Extension of, 389.
- Rates on merchandise for Glen Innes, Emmaville, &c., 394.
- Orange to Molong, Bathurst to Bourke, and Mudgee Line, 395, 535, 564, 577.
- Molong, 570, 590.
- Molong to Parkes, 583, 617.
- Molong to Wilcannia, via Parkes, 535.
- Loans, 396.
- Rates on cut wood, ores, &c., 399.
- Freight on Empty Sacks, Mineral Ores, &c., 490.
- Fares and freight on Homebush to Waratah Line, 400.
- Engaged compartments in railway carriages, 401, 439, 449, 458 (?), 495, 570.
- Sleeping-car for accommodation of the Honorable Messrs. Abigail and Inglis, 402.
- Public holidays for classified officers, 402.
- Woy Woy Platform, Homebush and Waratah Railway, 407.
- Smoking on platforms, 407.

## QUESTIONS—(continued):—

## RAILWAYS—(continued):—

- Engine-sheds and Changing-places, Dubbo and Wellington, 503.
- Charges for Carriage of Wheat, 504.
- Redfern into the City, 512.
- Buradoo Platform, 518.
- Line to Forbes, 521, 611.
- Resumption of Mr. John Black's Property on Homebush-Waratah Line, 523.
- Audit Branch, Newcastle, 523.
- To Wilcannia, 527 (4), 536; 540, 571.
- Sunday Train for Penrith, 529.
- Mullet Creek Embankments, 533.
- North Coast, 534.
- Orange to Molong, 577.
- Mr. C. Colls, 536.
- Board of Commissioners, 536, 557.
- Trial Surveys, Parkes to Condobolin, 545.
- Cartage of Wool, Produce, &c., from Darling Harbour, 546.
- Muswellbrook to Cassilis, 556, 559.
- Line to Inverell, 557.
- Goods Traffic, Molong, Borenore, and Cowra Stations, 559.
- Charges for demurrage and storage, 564.
- Locomotive Department, removal of Timekeepers, 572.
- Tunnel at Redfern, 576.
- Line to Codobolin, 576, 605, 617.
- Hornsby to North Shore, 578.
- Silver ore carried on, 581.
- Express Goods Train, 584.
- Via Borenore, 597.
- Return on capital, &c., 605.
- Fares of ladies accompanying Mr. W. J. Allen, M.L.A., to Bourke, 612.
- Delay of Mail Train between Granville and Parramatta, 612.
- Workshops at Bathurst, 618.

## RANDWICK:—

- Rifle Range, 450, 489.
- Discontinuance of Tolls, on road, 106.

## RATES (See "WHARVES")

## RATIONS:—For unemployed, National Park, 106.

## READ, MR.:—Government Meat Market, 285, 333.

## REAL PROPERTY ACT:—Assurance Fund, 179, 207, 261, 305, 341, 459.

## RECEIPT STAMPS:—For money paid on Public Service, 331.

## RECLAMATION WORK:—Cook's River, 262.

## RECREATION RESERVES (See "RESERVES")

## RECRUIT MONEY (See "VOLUNTEERS")

## REDFERN:—

- Public Parks, Electorate of, 239.
- Sewerage of, 412.
- Clock for Post and Telegraph Office, 412.
- Supply of stamps at Post Office, 413.
- Court-house, 413.
- Tram for Western Mail Train, 343, 534.
- Railway into City from, 512.
- Railway Tunnel at, 576.

## REFORMATORY:—

- Establishment of, for Boys, 28, 331.
- Rookwood, 612.

## REFRACTORY ORES:—Treatment of, 118.

## REFRESHMENT ROOMS (See "RAILWAYS")

## REFUNDS (See "CROWN LANDS")

## REGENT-STREET:—

- Wood-paving of, 412.
- Mittagong, opening of, 529.

## REGISTRAR-GENERAL'S DEPARTMENT:—Office Hours and Leave of Absence, 63.

## REGISTRARS OF BIRTHS:—Fees to District, 411.

## REGULATIONS:—

- For admission to the Bar, 8.
- Respecting Cattle sent from New South Wales to Victoria, 180.
- Marine Board, 414.

## RELIEF:—To the Poor of Sydney, 291.

## RELIEF WORKS (See "UNEMPLOYED" also "CHINESE")

## RELIGION:—State aid to, 143.

## RENTS (See "CROWN LANDS" also "QUIT RENTS")

## REPORTING STAFF:—Parliamentary, 240.

## RESERVES (See also "MILITARY," see also "FORESTS" also "VOLUNTEERS"):—

- Rushcutter's Bay, 13.
- Village, Captain's Flat, 47, 279.
- Parish of Dunoon, 83.
- Recreation, Adaminaby, 96.
- Do Cooma, 96.
- Do Maclean and Brushgrove, 121.
- Bulga Stock Road, Jerry's Plains to Homebush, 139, 163, 251.
- Travelling stock; on Eugowra and Canowindra, 179.

## Q

## QUESTIONS—(continued):—

## RESERVES—(continued):—

- Joadja Mining, 190, 563.
- Belmore, near Canowindra, 292.
- Made in 1886 and 1887, 284.
- Terania Forest, 307, 458.
- Eastern and Central Districts, 307.
- Maloga, 364.
- Recreation, and parks endowed and handed over to Councils, 384.
- Fronting Mossman's Bay, 406.
- Galathers and Boggy Creek Tanks, 415.
- Timber, 535.
- Taralba Coal-mining, 498, (2) 503, 521.
- Bondi, Occupation of by Aquarium Company, 553.

## RESERVOIR:—

- High-level at Pott's Hill, 356.
- Prospect, 432, 511.

## RESUMED AREA (See "CROWN LANDS")

## RESUMPTION OF LAND:—

- For Railway Purposes, 265, 271.
- High School, Elizabeth-street, Public School, Castlereagh-street, 424.
- Near Bradley's Head, 14.
- Macquarie-street and the Domain, 19.
- Robertson's Point, Cremorne, 153.

## REVENUE AND EXPENDITURE (See "FINANCE")

## REVENUES (See also "CROWN LANDS," also "ELECTORAL"):—

- Of Great Powers of Europe, America, and Australasian Colonies, 109.

## RICHARDSON, MAJOR-GENERAL:—Report on Rifle Clubs, 299.

## RICHMOND:—

- Common, 214.
- Park, 351.

## RICHMOND, THE:—

- Roads and Bridges in Electorate, 21.
- Land Court, 83.
- Tug for, 93.
- Tug Service, 164.
- Conditional Purchases, in District, 126, 207.
- Improvement of entrance of River, 276, 498.
- Navigation of River, 291.
- Boats for River, 292.
- Snagging operation on, 399.
- Sir John Coode's report on River entrance, 458.
- Noxious Weeds, 533.

## RIDLEY, MR.:—

- Bravery in South Waratah Coal-mine, 377.

## RIDLEY, MR. G. S.:—Employment of, as Crown Lands Agent, 522.

## RIFLE CLUBS:—

- Establishment of, 270.
- Report of General Richardson, 299.

## RIFLE RANGE:—Paddington and Randwick, 450, 489.

## RINGBARKING:—

- Effect of, on health and climate, 180, 262.
- Number of acres on which permission granted for, 290.

## RINKS SKATING:—

- Construction and Licensing of, 552.

## ROADS:—

- Clerks in Department, 168.
- Distribution of Additional Vote of £100,000, 7.
- And Bridges, Electorate of the Richmond, 21.
- Toogong to Murga, 27.
- Mount Macquarie to Carcoar, 34.
- Narrabri to Walgett, 39.
- Payment of Contractors, 39.
- Narramine to the Bogan, 51, 471.
- Moulamein to Koondrook, 57, 180, 184.
- Forbes and Eugowra, 57.
- Mr. Leonard, Road Contractor, 57.
- Department—Iron for Bridges, 62.
- Passing through Municipalities—Vote for, 62, 504.
- Between Cudal and Davy's Plains Run, 81, 280.
- Mr. E. Cannell, contract near Stone-quarry Creek Crossing, 105.
- Randwick, 106.
- Whaling, East St. Leonards, 125.
- Through E. K. Crace's Estate, Gungahleen, 139, 140, 436.
- Mr. White's purchase of, near Timor and Isis River, 142.
- Menindie to Kincheha, 154.
- Through Australian Agricultural Company's land, Warrah, 167.
- Belar Creek, Parish of Deringullen, 168, 340.
- Wanaaring to Tibooburra, 177.
- Byrock to Gongolgan, 183, 279.
- Maintenance Men, 206.
- Gunnedah to Barraba, 266, 289.
- Near Mr. Fergusson's Selection, Belabula, 272.
- St. Alban's to Mount Manning, 284.

## QUESTIONS—(continued)—

- ROADS—(continued)—  
 Maintenance men on, Boree to Parkes, 333.  
 Coonamble to Pilliga, 339.  
 Compensation to Joseph Gersbech, Parish of Canoblas, 348.  
 Near La Perouse, 412.  
 Auburn Park Trust, 424.  
 Contracts—Mr. Wells, Engineer, 449.  
 Woods-lane, near Quirindi, Yarraman Reserve, 472.  
 Botany, 474.  
 Tambulgum to Queensland Border, 523.  
 Grants for, 534.  
 Vote for Country, 633.
- ROBERTS, MR. H. R.:—Promotion of, in Central Police Office, 223.
- ROCK FLAT:—Public School, 437.
- RODD ISLAND:—Cost of Buildings for M. Pasteur's investigations, 460.
- ROOKWOOD:—  
 Church of England Chaplain at Cemetery, 141.  
 Reformatory, 612.  
 Railway Station, 607.
- ROLLS:—(See "ELECTORAL")
- ROSS, WILLIAM:—Late Overseer at National Park, 51.
- ROYAL NAVAL HOME:—Site for, 94.
- ROYALTY:—On Oysters, 83, 94, 105, 142.
- RUNS (See also "CROWN LANDS")
- RUSHCUTTER'S BAY:—Reserve, 13.
- RUSSELL'S WHARF:—Resumption of, by the Government, 8.
- RYDE:—Mr. Manning, Coroner at, 270.
- RYLSTONE:—Police Quarters, 483.
- RYRIE, MESSRS.:—Land belonging to, resumed for Railway purposes, 217.
- SACKS, EMPTY:—Railway freights on, 490.
- SALARIES (See "CIVIL SERVICE")
- SALVATION ARMY:—Interference with, by Police, 33.
- SAMOA:—Action of the Germans in, 20.
- SAN FRANCISCO MAIL CONTRACT:—Claim of Pacific Mail Steamship Company, 239.
- SAVINGS BANKS:—  
 Deposits, &c., in, at Forbes, Parkes, and Molong, 582.
- SCHOOL ATTENDANCE OFFICERS (See "EDUCATION")
- SCHOOLS OF ARTS:—  
 Site for, Wee Waa, 239, 299.  
 Supply of *Hansard* and *Government Gazette* to, 245.  
 Endowments, 534.
- SCOTT, MR.:—Police Magistrate, Deniliquin, 173.
- SCOTT, MR.:—Locomotive Engineer, 327, 477.
- SEA-WALL:—Coogee Bay, 106.
- SEAWEED:—  
 Nuisance of, at Botany, 32, 70, 333, 412.  
 Do Double Bay, 110.
- SEED POTATOES:—Supplied to persons in Clarence Electorate, 171.
- SELFE, MR. NORMAN:—Improvements at Circular Quay, 388.
- SEWERAGE (See also "METROPOLITAN WATER AND SEWERAGE BOARD")  
 Eastern Suburbs, 16, 164.  
 Blasting in connection with works, 118.  
 Board for control of Bondi Scheme, 126.  
 Bondi Sewer, 154.  
 Western Suburbs, 267 (°) 546, 558.  
 Redfern, 412.
- SHARES:—Liable to forfeiture, 372.
- SHELLHARBOUR:—  
 Dredge for, 195.  
 Wharf at, 209.
- SHERIFF'S OFFICERS:—  
 Recovery of Fees due to, 83.  
 Bailiff's mileage charges, 209.
- SHERIDAN, MR. PHILIP:—Trustee of Association Cricket Ground, 447, 518.
- SHERWOOD:—Letter-carrier for, 301, 388.
- SHOALHAVEN:—Entrance to River, 572.
- SHOW-GROUND, WALGETT, 352.
- SIBLEY, DR. J. C.:—Health Officer, Watson's Bay, 448.
- SICKNESS:—In Public Schools, 214.
- SILVER-MINING:—"Boom" in connection with, 341, 371.
- SILVER ORE:—Carried by Railway, 581.
- SILVERTON:—  
 Mail service between Menindie and, 153.  
 Tramway to Thackaringa and Purnamoota, 235.  
 Court-house, 372.
- SINGLETON:—  
 Court of Quarter Sessions at, 218.  
 Railway trial survey, *via* Jerry's Plains, towards Cassilis, 448.  
 Erection of Munro Drinking Fountain, 448.
- SITE FOR VILLAGE:—Parish of Heyden, county of Wellesley, 536.
- SKATING RINKS:—Construction and Licensing of, 552.

## Q

## QUESTIONS—(continued)—

- SKENE, WILLIAM:—Prelease of, at Conargo, 143.
- SLEEPING CARS:—  
 Cost of Railway, 118.  
 For accommodation of The Honorable Messrs. Abigail and Inglis, 402.
- SLY, DR.:—Employment of, by Government, 101 (°), 110.
- SMALL ARMS AMMUNITION:—Establishment of Manufactory, 414.
- SMITH, THE HON. J. (See also "CROWN LANDS"):—  
 Arbitration Case *v.* Commissioner for Railways, 51, 80, 96, 102.
- SMITH, MR. T. R.:—Alleged appointment of, under Government, 142, 214.
- SMITHFIELD:—Municipality of, 612.
- SMOKING:—On Railway Platforms, 407.
- SNAGGING:—  
 Mooney Mooney Creek, 324.  
 Operations, Richmond River, 399.
- SOCIETIES (See "AGRICULTURAL")
- SOILED LINEN (See "QUARANTINE")
- SOUDAN CONTINGENT:—Stores returned from Suakim, 179.
- SOUTH WARATAH COAL-MINE:—Bravery of Mr. Ridley in, 377.
- SPANGENBERG, WILLIAM:—Application of, for a Billiard License, 38 (°).
- SPAT (See "OYSTERS")
- SPECIAL GRANTS:—To Municipalities, 495, 511.
- SPECIAL TRAINS (See "RAILWAYS")
- SPIRITS:—  
 Duties paid on, 31.  
 Importation of, 368.
- SPIT:—Bridge over Middle Harbour at, 27.
- SQUATTERS:—Persons employed by, 313.
- ST. ALBANS (See also "ROADS"):—  
 Court-house, 178.
- STAFFORD WILLIAM, EX-SERGEANT:—Dismissal of from Police, 557.
- STAMP OFFICE:—Mr. Foskett, 214, 299.
- STAMPS (See also "RECEIPT STAMPS")  
 Supply of to Redfern Post Office, 413.
- STANMORE:—  
 Post and Telegraph Office, 276.  
 Revenue received at Railway Station, 313.
- STATE AID TO RELIGION:—Final abolition of, 143.
- STATE HOUSE:—  
 Competition in designs for, 155.  
 Plans, specifications, and tenders, 319.  
 Authority for expenditure under, 355.  
 Erection of, 383.
- STATION-MASTER (See "RAILWAYS")
- STATISTICAL REGISTER:—Handbook to, 75.
- STATISTICS:—Crown Lands, 461.
- STATUARY:—Purchase of, by the Government, 227, 592.
- STAUNTON, MAJOR:—Free pass issued to, 134.
- STEAMERS:—Use of cast-iron propellers by, 139.
- STEAM-LAUNCHES:—Employment of Government, 143.
- STEAM LAUNCH:—Mabel, 275.
- STEPHEN *v.* ERWIN:—Decree, 332, 511.
- STIPENDIARY MAGISTRATES:—  
 Complaints against Mr. Addison, 167.  
 Do other, 215.  
 Number of cases dealt with by Mr. Addison at one sitting, 173.  
 And Deputies, 190.  
 Mr. Deputy Delohery, 331.
- ST. LEONARDS:—  
 Railway from Pearce's Corner (Hornsby), 16.  
 Railway from Pearce's Corner to Waters of Port Jackson, 84, 97.  
 Whaling Road, 125.
- STOCK:—  
 Watering places for travelling, 19.  
 Sale of diseased cattle, 20.  
 Disease in, District of Bourke, 81.  
 Road, Jerry's Plains to Homebush, 139, 163.  
 Diseases in, 262.  
 Route, Moulamein, 285.  
 Reserves for travelling, 179.  
 Regulations respecting, passing from New South Wales to Victoria, 180.  
 Route, Moulamein to Koondrook, 180, 371.
- STOCK ACT:—Consolidation of, 272.
- STOCK AND PASTURES BILL:—Consideration of, 428.
- STORAGE:—Charge for, 564.
- STORES, MILITARY:—Returned from Suakim, 179.
- STRATHFIELD:—Railway Station, 582.
- STRAY CATTLE:—In country towns, 33.
- STREET:—  
 Formation of, North of General Post Office, 396.  
 Johnson's estate and Petersham railway station, 536.

## Q

## QUESTIONS (continued) :—

- SUAKIM :—Military Stores returned from, 179.  
 SUBPENAS :—Charge for, 110.  
 SUBSIDY (See "RABBIT-PEST")  
 SUBURBS :—  
   Sewerage of Eastern, 16.  
   Sewerage of Western, 267 (?), 546, 558.  
   Drainage of Western, 546.  
   Railway Fares to, 217.  
   Water Supply, 597, 601.  
 SUBURBAN RAILWAYS (See "RAILWAYS")  
 SUB-WAY (See "RAILWAYS")  
 SUNDAY :—Railway and Tramway Traffic, 217.  
 SUPERANNUATION FUND (See "CIVIL SERVICE")  
 SUPERINTENDENT OF TELEGRAPHS :—Leave of absence, 340.  
*Supersedeas* (See "ADMINISTRATION OF JUSTICE")  
 SUPREME COURT APPEALS ACT :—Cases decided under, 117.  
 SURGEON, UNREGISTERED :—Services to Railway employés, 490.  
 SURVEY OFFICES (See "CROWN LANDS")  
 SUTHERLAND, MISS :—Public School, Cooma, 436.  
 SWEEPS :—Betting and "Consultations," 218.  
 SYDNEY :—  
   Public Expenditure in, and Country Districts, 7.  
   Water Supply, 597.  
 SYDNEY COMMON :—Land taken from, 300.  
 SYDNEY HOSPITAL :—Case of John Halloran, 257.  
 SYDNEY (See "RAILWAYS")  
 SYDNEY PERMANENT FREEHOLD LAND AND BUILDING SOCIETY :—Chairman of, 441.  
 SYPHON :—Tender for laying of, in George-street West, 606.  
 TALBRAGAR :—Reservations for Mining purposes, 96.  
 TANKS (See also "RESERVES") :—  
   In Eastern and Western Districts, 461.  
 TARAGO :—Railway Station, 368.  
 TARBAN CREEK :—Bridge over, 313.  
 TARANA :—Railway to Jenolan Caves, 56, 167.  
 TEACHERS (See "EDUCATION")  
 TECHNICAL COLLEGE :—Students travelling on Trams or Railways, 168.  
 TECHNICAL EDUCATION (See "EDUCATION")  
 TELEGRAPHS (See also "POSTAL") :—  
   Department—Mr. Leeson, 111, 126.  
   Iron Poles, 62, 127, 340.  
   Operators, 45.  
   Purchase of Wire, 45, 67, 80.  
   Brush Carbons, 46.  
   Materials supplied by H. H. Kingsbury & Co., 46, 127, 251.  
   Line to Milparinka or Mount Browns (Tibooburra), 177.  
   Sixpenny telegrams, 181.  
   Communication with Perth Railway Station, 196.  
   Stations using quadruplex instruments, 206.  
   Office at Gladesville, 267.  
   Horses purchased by Department, 271, 301, 383, 459, 512.  
   The "Gulcher" Electric Machine, 74, 106, 272, 305, 373.  
   Office at Stanmore, 276.  
   Messengers, 300.  
   Office, Orange, 323.  
   Communication between various Racecourses, 332.  
   Amalgamation with Money Order and Postal Systems, 340.  
   Superintendent of, 340.  
   Employment and dismissal of line repairers, 337.  
   Condemned poles, 387.  
   And Post-office, Wollombi, 393.  
     Do. Stanmore, 276.  
     Do. Bourke, 39, 215, 498.  
     Do. Redfern, Public Clock for, 412.  
     Do. Molong and Condobolin, 559.  
   Department, 405, 431, 453, 474, 490, 540, 583, 589, 591, 634.  
   Buildings rented as Telegraph Offices, 424.  
   Office, Broken Hill, 428.  
   Probationers connected with Railways, 448.  
   Station-master, Palmero Island, 453.  
   Masters at Parramatta, Grafton, Cootamundra, and Braidwood, 473.  
   Line from Tumbulgum to Tweed River, 477.  
   Increases to employés, 529.  
   Bourke to Wanaaring, 541.  
   Cable Communication with Europe, 533.  
 TELEPHONE :—  
   Exchange for Paddington, 173.  
   Frieze in George-street for telephonic system, 7, 265.  
   George-street Tunnel for system, 46, 68.  
   Cable for Frieze, 46, 127, 265, 453, 490.  
   Multiple-cable purchased by Telegraph Department, 266.  
 TEMPE :—Flooding of district by Railway embankment, 179.  
 TENTERFIELD (See also "RAILWAYS")  
   Railway to Queensland Border (Wallangarra) 15, 183.  
 TERALBA COAL MINING RESERVE :—  
   Mineral Conditional Purchases on, 498 (?) 503, 521, 617.

## QUESTIONS (continued) :—

- TERRY & Co. :—Claim of, on Railway Department, 164.  
 TERANIA :—Forest Reserve, 307, 458.  
 THACKARINGA :—Tramway from Silverton to, 235.  
 THEATRES :—Dangerous condition of, 533.  
 THEFTS :—Of Workmen's Tools, 134, 265, 276.  
 THOMAS, MR. :—Formerly inmate of Gladesville Asylum, 402, 473.  
 THOMAS, MR. WILLIAM, J.P. :—Appointment as Justice of the Peace, 541.  
 THOMSON, MR. :—Chief Inspector of Accounts, 153.  
 THROUGH TICKETS :—  
   Railway, Sydney to Brisbane, 292.  
   Sydney to Melbourne, *via* Blayney, 363.  
 TIBOOBURRA :—  
   Public School for, 177.  
   Telegraph line, Milparinka or Mount Browne, 177.  
   Road from Wanaaring, 177.  
 TIMBER :—  
   Destruction of, on Burrawong Run, 52.  
   Licenses, 327.  
   Reserves, 535.  
 TIMBER DUTIES (See "CUSTOMS")  
 TIME-TABLES :—  
   Printing of Railway and Tramway, 15.  
   Delay in issue of Railway, 319.  
   In Chinese language, 333.  
 TINDALL, DETECTIVE (See "POLICE")  
 TOOGONG :—Road, to Murga, 27.  
 TORPEDO :—  
   Storage of Hooper's Core, 87.  
   Armoured Electric Cable, 87.  
   Jardine Spar, 105, 141.  
   Pay of Corps, 121.  
   Cables, 373.  
 TRAFFIC (See "RAILWAYS")  
 TRAINS (See "RAILWAYS")  
 TRAINING SCHOOL :—Education Department, 484.  
 TRAINING INSTITUTION (See "EDUCATION")  
 TRAINING SHIP (See "VERNON")  
 TRAMWAYS :—  
   Employés Newcastle, 15, 540.  
   Do Drivers and Firemen, 275, 285.  
   Time-tables, 15.  
   Electric Motors for, 56.  
   Kogarah-Sans Souci, 56.  
   Ashfield and Druitt Town, 57.  
   Free Passes to Officials of Department, 68.  
   Land resumed for, 74.  
   North Shore, 75.  
   Advertising on, 97, 356.  
   Bridge-street to Railway Station, 109.  
   Belmore Park Crossings, 110.  
   Marrickville to Dulwich Hill, 134, 633.  
   First-class car, Sydney to Woollahra, 135.  
   Watering Routes, 165.  
   Students at Technical College travelling on, 168.  
   Extensions, 195.  
   Sunday traffic, 217.  
   Silverton to Thackaringa and Purnamoota, 235.  
   Field of Mars, 240, 266, 343, 598.  
   Time-tables in Chinese language, 333.  
   Tram to meet Western mail train at Redfern, 343, 534.  
   Proposals to work with compressed air, 396.  
   North Shore cable employés, 407.  
   Construction of cars, 413.  
   Botany Road line, 413.  
   And Railway Employés, 441, 540.  
   Guards, 450, 545.  
   Total miles and cost of, 498.  
   Darling-street Wharf, Balmain, to Leichhardt, 543.  
   Construction, 633.  
 TRANSIT COMMISSION :—  
   Employés, License Fees, Revenue and Expenditure, 383.  
   Solicitor, 447.  
   Inspector-General of Police, seat on Board, 457, 551.  
   Mayor of Sydney, seat on Board, 551.  
 TRAVELLING STOCK :—Reserves, 179.  
 TREASURER'S ADVANCE ACCOUNT (See "FINANCE")  
 TREASURY, THE :—Assistant Examiner of Accounts, applications for position of, 473.  
 TREATT, MR. F. B. :—Chief Clerk, Immigration Department, 534.  
 TRIAL SURVEYS (See "RAILWAYS")  
 TROLOPE, MR. F. G. A. :—Tumut and Gundagai Land Boards, 406.  
 TRUST FUNDS :—Under control of Government, 396, 400.  
 TRUSTEES (See "ASSOCIATION CRICKET GROUND")  
 TUG :—  
   For Richmond River, 93.  
   Service, Richmond River, 164.

## Q

## QUESTIONS (continued):—

- TUMBERUMBA**:—Post and Telegraph Office, 57.  
**TUMBULGUM**:—  
 Telegraph Line to Tweed River, 477.  
 Road to Queensland Border, 523.  
**TUNNEL UNDER GEORGE-STREET** (See "TELEPHONE")  
**TURON RIVER**:—Bridge over, at Wallaby Rock, 48.  
**TWEED, THE**:—  
 Dredge for River, 276, 575.  
 Navigation of River, 291.  
 Telegraph Line from Tumbulgum to Heads, 477.  
**TYPHOID FEVER**:—  
 Measles and, in Alexandria and Waterloo, 111.  
 At Mr. Anthony Hordern's establishment, 126.  
 M. Pasteur's Investigations, 460.  
**ULMARRA**:—Light Horse, 363.  
**UNEMPLOYED**:—  
 Free Railway Passes to, 20.  
 Labour Bureau, 33.  
 Casino Municipal Council, 75.  
 Rations for, National Park, 106, 283.  
 Casual Labour Board, 125.  
 Work on Holt-Sutherland Estate by, 150.  
 Particulars respecting, 172.  
 Engineers, fitters, ironmoulders, and blacksmiths, on relief works, 253, 300.  
**UNIVERSITY OF SYDNEY**:—  
 Examination Fees, 347.  
 Department of Engineering, 497.  
**UNWHOLESOME MEAT**:—Delivery of, for consumption, 213.  
**VENTILATION OF MINES**:—Appointment of Board, 368.  
**"VERNON," THE**:—  
 Training Ship—Prisoners in Gaols, 420.  
 Numbers of officials, duties, and leave granted, 312.  
 Boys absconded from, 318.  
**VESSELS**:—Laid up in Johnston's Bay, 207.  
**VETERINARY SCHOOL**:—Erection of, in connection with University, 395.  
**VICTORIA**:—  
 Regulations respecting Cattle sent from New South Wales to, 180.  
 Prohibition of importation of Grapes into, 256.  
**VILLAGE**:—Site for, parish of Heyden, county of Wellesley, 536.  
**VILLAGE RESERVE**:—Captain's Flat, 47.  
**VINEYARDS**:—  
 Phylloxera in, 155.  
 Board of Inquiry into Phylloxera, 490.  
**VOLUNTEERS**:—  
 Molong Corps, 280, 337.  
 Recruit money due to, 301.  
 Easter Encampment, 318, 334, 337, 359.  
 Ulmarra Light Horse, 363.  
 Martini-Henry Rifles, 459, 475, 489.  
 Capitation Allowance, Reserve Corps, 471.  
 Rifle Range, Paddington and Randwick, 450, 489.  
 Country Cavalry Corps, 497.  
 Formation of Force, Lismore, 533.  
 Artillery, 541.  
**VOUCHERS**:—Furnished by Public Officials for moneys paid, 251.  
**WAGGA WAGGA**:—Local Land Board and Survey Office, 28, 261.  
**WALGETT**:—  
 Road from Narrabri, 39.  
 Railway from Narrabri, 39, 150.  
 Show Ground, 352.  
**WALLABDAH COMMON**:—Dedication of, 337.  
**WALLANGARRA**:—Railway, Tenterfield to, 183.  
**WANAARING**:—  
 Road from to Tibooburrah, 177.  
 Bore for water, 292.  
 Telegraph from Bourke, 541.  
**WARATAH**:—Railway, Homebush to, 95, 400.  
**WARDENS UNDER MINING ACT**:—Police Magistrates appointed as, 227, 245.  
**WAREHOUSES, BONDED**:—Kerosene Oil, &c., in, 491.  
**WARIALDA** (See "CROWN LANDS")  
**WARRAH**:—Road through the A. A. Company's land, 167.  
**WATERING-PLACES**:—For travelling stock, 19.  
**WATERLOO**:—Measles and Typhoid Fever in Alexandria and, 111.  
**WATER RATES** (See "METROPOLITAN WATER AND SEWERAGE BOARD")  
**WATER SUPPLY**:—  
 Nepean—Control of, 32, 126.  
 Do Expenditure on, 154.  
 Byrock, 38.  
 Conservation of, in Country, 61.  
 Carrying out proposals of Royal Commission, 172.  
 Euriovie, 80.  
 Brass fittings for Country Towns, 218.

## QUESTIONS (continued):—

- WATER SUPPLY**—(continued):—  
 Water Reservoir near Cobar, 284.  
 Wanaaring Bore for, 292.  
 Construction of High-level Reservoir at Pott's Hill, 356.  
 Moama, 364.  
 Germanton, 395.  
 Prospect Reservoir, 432, 511.  
 Newcastle, 571.  
 Prospect Works, Messrs. Mills & Shand, 581.  
 Railway Station, Albury, 584.  
 Sydney and Suburbs, 597.  
 Certain Suburbs, 601.  
**WATER AND SEWERAGE BOARD** (See "METROPOLITAN WATER AND SEWERAGE BOARD")  
**WATSON'S BAY**:—  
 Jetty at, 564.  
**WAVERLEY**:—  
 Foreshores of, and Bondi, 134.  
 Church of England Chaplain at Cemetery, 141.  
 Gateways to Centennial Park, 478.  
**WELLINGTON**:—  
 Police Quarters at, 179.  
 Engine-sheds and changing place at, 503.  
**WENTWORTH** (See also "CROWN LANDS"; also "RABBIT PEST") :—  
 Customs Duties collected at, 38.  
**WENTWORTHVILLE**:—Railway platform, 105.  
**WEE WAA**:—  
 Site for School of Arts, 239, 299.  
 Public Park for, 272.  
**WEEDS** (See "NOXIOUS WEEDS")  
**WELLS, MR.**:—Tenders for Road Contracts, 449.  
**WESLEYAN MINISTERS**:—Free Passes to, 457.  
**WESTERN MAIL TRAINS**:—Tram to meet, 343, 534.  
**WESTERN SUBURBS**:—  
 Sewerage of, 267 (?), 546, 558.  
 Drainage of, 546, 634.  
 Burglaries in, 618.  
**WHALING ROAD**:—Opening of, 125.  
**WHARVES**:—  
 Shellharbour, 209.  
 Moama, 289.  
 Public Botany, 411.  
 Rebate of Rates on Public, 535.  
 Erection of, at Bourke, 598.  
**WHEAT**:—Charge for carriage of, 504.  
**WHITE, MR. FREDERICK**:—Purchase of Roads near Timor and Isis River by, 142.  
**WHITE, THE MESSRS.**:—Runs held in Upper Hunter Electorate, 591.  
**WHITTINGHAM**:—Railway Station, 142.  
**WILCANNIA**:—  
 Customs Duties collected at, 38.  
 Bridge over the Darling at, 311, 528.  
 Athenæum at, 364.  
 Railway Line to, 527 (?), 536, 540, 571.  
 Court House at, 577 (?).  
 Railway Extension from Molong, via Parkes, 535.  
**WILKINSON, MR. H. T.**:—Official connection of, with Norfolk Island, 172.  
**WILKINSON'S AUSTRALIAN MAGISTRATE**:—Supply of, 45.  
**WINDSOR** (See "RAILWAYS")  
**WINES**:—Duties paid on, 31.  
**WIRE** (See "TELEGRAPHS")  
**WISE, MR. G. F.**:—Immigration Agent, 534.  
**WOOD**:—Differential Railway rates on carriage of, 313.  
**WOODS-LANE** ("See ROADS")  
**WOOD-PAVING**:—  
 Circular Quay, 301.  
 Pitt-street South, 408.  
 Regent-street, 412.  
**WOLLOMBI**:—Post and Telegraph Office, 393.  
**WOLLONGONG** (See also "RAILWAYS") :—  
 Railway loop-line near, 199.  
**WOOLAHRA**:—First-class tram car running to, 135.  
**WOOL**:—Cartage of, from Darling Harbour, 546.  
**WORKMEN** (See also "RAILWAYS") :—  
 Theft of Tools of, 134, 265, 276.  
 Railway rates on tools of trade, 376.  
 Prospect Reservoir, 511, 564.  
**WOY WOY PLATFORM** (See "RAILWAYS")  
**WRIGHT, SENIOR-CONSTABLE**:—Case of, 440.  
**WYONG CREEK** (See "BRIDGES")  
**YARRALUMLA**:—Conditional Purchases, 154.  
**YARRAMAN RESERVE**:—Woods-lane, near Quirindi Road, 472.  
**YATES, MR. LEOPOLD**:—  
 Position of, in Civil Service, 180.  
 Leave of absence, 351.  
**YEOMANS, MRS.**:—Inquiry into cause of death, 74.  
**YOUNG**:—Magistrates, 341.

REFERENCES TO THE VOTES AND PROCEEDINGS, VOL. I—13TH PARLIAMENT.—SESSION, 1887-8.	PAPERS.
	VOL. PAGE.
<b>Q</b>	
QUIT RENTS:—	
Return to Order ( <i>Session 1887</i> ) laid on Table, 559 .....	5 195
QUORUM (See "NO QUORUM")	
<b>R</b>	
RABBIT NUISANCE ACT AMENDMENT BILL:—	
Motion made ( <i>Mr. Abigail</i> ) for leave to bring in, presented and read 1 <sup>o</sup> , 200; motion made for 2 <sup>o</sup> and Debate adjourned, 225; Order of the Day discharged, and Bill withdrawn, 241.	
RABBIT PEST:—	
Return to Order ( <i>Second Session, 1887</i> ), laid on Table, 150 .....	8 973
Motion made ( <i>Mr. Wall</i> ) for a return showing miles of wire netting now erected by the Government for the prevention of rabbits, with all costs incident thereto, 191; Return to Order laid on Table, 223 .....	8 979
Motion made ( <i>Mr. J. P. Abbott</i> ) for reports of Mr. Stanley, on disease introduced by Drs. Butcher and Ellis, 287.	
DESTRUCTION OF RABBITS BY MEANS OF DISEASES:—	
Report of Health Board and other papers on proposals for, laid on Table, 335 .....	8 955
RABBIT PEST SUPPRESSION BILL:—	
Motion made ( <i>Mr. Garrett</i> ) for Committee of the Whole, 263; Message from Governor, 268; House in Committee, Resolution reported and agreed to, 309, presented and read 1 <sup>o</sup> 317.	8 981
RAILWAYS (See also "GOVERNMENT RAILWAYS BILL"; also "NORTH SHORE, MANLY, AND PITTSWATER TRAMWAY AND RAILWAY BILL"; also "OAKEY PARK COAL-MINING COMPANY'S RAILWAY BILL"; also "REDHEAD COAL-MINE RAILWAY ACT AMENDMENT BILL"; also "GOVERNMENT RAILWAYS ACT AMENDMENT BILL"; also "YOUNG WALLSEND COAL COMPANY'S RAILWAY BILL"):—	
ACCIDENT AT PETERSHAM BRIDGE:—	
Motion made ( <i>Mr. McElhone</i> ) for all correspondence, reports, &c., in reference to, 48.	
Report by Mr. Wm. Cruickshank, M.I.C.E., relative to, laid on Table, 103 .....	6 617
ACCIDENT, PEAT'S FERRY:—	
Motion made ( <i>Mr. Schey</i> ) for all reports, evidence, recommendations, and all attainable information relating to, 128; Return to Order laid on Table, 635 .....	6 467
ALLEGED FRAUDS:—	
Return to Order ( <i>Second Session, 1887</i> ) laid on Table, 122 .....	6 631
AND TRAMWAYS OF NEW SOUTH WALES:—	
Report for 1886, laid on Table, 6 .....	6 1
Do for 1887, laid on Table, 635 .....	6 225
APPOINTMENTS MADE IN THE DEPARTMENT:—	
Motion made ( <i>Mr. Lyne</i> ) for a Return showing permanent and temporary, since 1st January, 1887, 40; Return to Order, laid on Table, 231 .....	2 97
BOWBAL STATION:—	
Motion made ( <i>Mr. M'Court</i> ) for papers in reference to the improvement of, 506; Return to Order laid on Table, 578. (Not printed.)	
BOWBAL OR MOSS VALE TO ROBERTSON:—	
Motion made ( <i>Mr. M'Court</i> ) for papers in reference to construction of, 519.	
BLUE METAL FOR TRAMWAYS AND:—	
Motion made ( <i>Mr. O'Sullivan</i> ) for all tenders, minutes, and papers relating to purchase of 3,000 tons, 48; Return to Order, laid on Table, 122 .....	6 1109
BYBROOK TO BREWARRINA:—	
Motion made ( <i>Mr. Waddell</i> ) for construction of light line, and by leave withdrawn 370.	
CARRIAGE OF WOOL AND OTHER PRODUCE:—	
Original tenders for, from the Railway Station, Redfern, and Darling Harbour, laid on Table ( <i>as Exhibits only</i> ), 454.	
CLAIM OF MRS. BUTTERLEY:—	
Motion made ( <i>Mr. Schey</i> ) for a Select Committee, and Return to Order ( <i>Second Session, 1887</i> ) referred, 12; Report brought up, 140 .....	6 647
COBAR:—	
Return to Order ( <i>Second Session, 1887</i> ), laid on Table, 5 .....	6 997
COLO VALLEY RAILWAY SURVEY:—	
Motion made ( <i>Mr. Frank Farnell</i> ) for papers, 303; Returns ( <i>in part</i> ) to Order, laid on Table, 348, 352 .....	6 1047, 1067
COMBINATION TRUCKS:—	
Return respecting service of, in use from 1st January to 30th June, 1886, laid on Table, 6 .....	6 617
Further correspondence respecting Evans patent, laid on Table, 49, 71 .....	6 937, 945
Motion made ( <i>Mr. Lyne</i> ), that this House do now adjourn to consider the payment of £16,000 by the Government for the Evans patent, and by leave withdrawn, 53.	
Correspondence respecting, designed by Messrs. Wilkinson, Perry, Anderson, and Brazenor and Valentine, laid on Table, 88 .....	6 919
Motion made ( <i>Mr. Hassall</i> ) for a Select Committee to inquire into, 130; correspondence laid on Table, referred, 151, 302; authorized to make visits of inspection, 155; Report brought up, 626 .....	6 815
Petitions from persons interested praying to be heard in person or by Counsel before the Select Committee, presented, 144, 150 .....	6 913, 915
Further correspondence respecting Wilkinson's and the Evans' trucks, laid on Table, referred to Select Committee on "Combination Trucks," 302 .....	6 953
Further correspondence respecting Wilkinson's patent, laid on Table, 360; referred to Select Committee, 389 .....	6 933
CONSTRUCTION:—	
Motion made ( <i>Mr. O'Sullivan</i> ) that, like roads, should be constructed more with a view to settle the country and give cheap access to markets than for commercial profit, that light railways should be preferred to roads, that interest on the money borrowed be provided for by a graduated tax on the land enhanced in value by such railways, and withdrawn, 232.	
CONTINUOUS BRAKE:—	
Return respecting, laid on Table, 635 .....	6 959
COOMA TO BOMBALA:—	
Motion made ( <i>Mr. Dawson</i> ) for all papers and correspondence connected with the trial survey of the extension, 76; Return to Order laid on Table, 277 .....	6 1041
CROSSING TO CONNECT EASTGROVE WITH GOULBURN:—	
Motion made ( <i>Mr. Teece</i> ) for papers, 336; Return to Order laid on Table, 454 .....	6 907

REFERENCES TO THE VOTES AND PROCEEDINGS, VOL. I—13TH PARLIAMENT—SESSION, 1887-8.	PAPERS.	
	VOL.	PAGE.
<b>R</b>		
<b>RAILWAYS—(continued) :—</b>		
<b>DIFFERENTIAL RATES :—</b>		
Motion made ( <i>Mr. Lyne</i> ) for all papers, correspondence, &c., in reference to the origin and continuation of, 103.		
<b>EDDY, MR. E. M. G. :—</b>		
Correspondence respecting the appointment of, as Chairman of Railway Board, laid on Table, 537.	6	625
<b>EMPLOYEES :—</b>		
Information respecting the Officers in the Department of Public Works and Permanent-way men, laid on Table, 28	8	1053
<b>EXTENSION TO BROKEN HILL, SILVERTON, AND THE BARRIER RANGES :—</b>		
Motion made ( <i>Mr. Garland</i> ) that any railway policy submitted to Parliament should include, and withdrawn, 273.		
<b>FREE PASSES :—</b>		
Return respecting, laid on Table, 519	6	721
<b>FREE PASSES TO SCHOOL CHILDREN :—</b>		
Motion made ( <i>Mr. Abbott</i> ) for all minutes, and other documents, written or sent by any Minister, or officer in their Departments, or by the Commissioner, in reference to the resolution authorizing the free carriage of children who were attending schools, 40; Return to Order, laid on Table, 231	6	711
<b>FREE PASSES TO JUDGES OF LIVE STOCK :—</b>		
Motion made ( <i>Mr. Wall</i> ) for Committee of the Whole to consider expediency of issuing, journeying to and from Pastoral and Agricultural Shows, and negatived, 59.		
<b>FREE PASSES TO EX-MEMBERS OF THE LEGISLATIVE ASSEMBLY :—</b>		
Motion made ( <i>Mr. Haynes</i> ) that the Resolution affirming that members returned to three Parliaments, on ceasing to be members, shall be entitled to a permanent free pass,—be rescinded, and debate adjourned, 129; Order of the Day postponed, 433; Order of the Day discharged 506.		
<b>FREE PASSES ISSUED BY THE MILITARY STAFF OFFICE TO VOLUNTEERS :—</b>		
Return respecting, during the quarter ended 30 June, 1888, laid on Table, 524	6	723
<b>FREIGHT OF CONTRACTORS PLANT AND MATERIAL :—</b>		
Return showing, paid to Department by various Contractors during years 1883 to 1886 respectively, laid on Table, 28	6	747
<b>GRANVILLE TO PENRITH :—</b>		
Information respecting Duplication of Line, laid on Table, 360	6	1023
<b>GOULBURN TO THE COOMA LINE JUNCTION :—</b>		
Motion made ( <i>Mr. O'Sullivan</i> ) for papers in connection with duplication of 314: Return to Order laid on Table, 559	6	979
<b>GREAT NORTHERN AND NORTH-WESTERN RAILWAYS :—</b>		
Return respecting passenger traffic on, laid on Table, 389	6	733
<b>HARDEN STATION :—</b>		
Motion made ( <i>Mr. Gordon</i> ) for return showing goods and passenger traffic, revenue, and expenditure at, 294; Return to Order, laid on Table, 338	6	741
<b>HOMEBUSH TO WARATAH :—</b>		
Return respecting the construction of, laid on Table, 191	6	1021
Return respecting fares and freights, laid on Table, 512	6	743
<b>INVERELL :—</b>		
Petitions in favour of route from Guyra <i>via</i> Wandsworth and Tingha, presented, 84, 529	6	1033, 1035
<b>IRON AND STEEL RAILWAY AND TRAMWAY MATERIALS :—</b>		
Motion made ( <i>Mr. Fletcher</i> ) for particulars of purchase of, 479.		
<b>ISAAC WERRELL, GATEKEEPER, RAILWAY DEPARTMENT :—</b>		
Information respecting compensation to family of, laid on Table, 403	6	645
<b>LAND RESUMED FOR, AND TRAMWAY PURPOSES :—</b>		
Motion made ( <i>Mr. Schey</i> ) for return showing amount of compensation paid annually for, during the last seven years, giving particulars, 103; Return to Order laid on Table, 267	6	1115
<b>LAND RESUMED FOR, AT BEXLEY :—</b>		
Motion made ( <i>Mr. Hurley</i> ) for a Select Committee to inquire into and report upon, 233.		
<b>LIMITED EXPRESS TRAIN :—</b>		
Information respecting compartments engaged in, from 1st November, 1887, to 1st April, 1888, laid on Table, 385	6	727
<b>LOCOMOTIVE ENGINES :—</b>		
Motion made ( <i>Mr. Lyne</i> ) for all papers, correspondence, and reports, in connection with the late tests of the "Vulcan" and "Mogul," 40.		
Motion made ( <i>Mr. Fletcher</i> ) for all tenders and correspondence relating thereto, for manufacture of, required by the Government, 41.		
Motion made ( <i>Mr. Wall</i> ) for a return showing the number employed during twelve months ending 1st September, 1887, conveying trains between Mount Victoria and Penrith; also the number used in conveying same trains between Penrith and Sydney, 58; Return to Order, laid on Table, 81	6	807
Papers relative to Tenders for, and Tests for suitable Type of, laid on Table, 71	6	757
Further correspondence respecting Tests for suitable Type of Engines, laid on Table, 88	6	805
Motion made ( <i>Mr. Fletcher</i> ) for a return showing the cost of "Heavy Consolidated," "Mogul," and "Vulcan," in running order, and of the class which the Government have decided to adopt, including all charges, 103; Return to Order, laid on Table, 496	6	811
Motion made ( <i>Mr. Copeland</i> ) for correspondence, &c., in connection with calling for tenders and recent letting of contracts for, in the Colony, 479.		
Return respecting manufacture of, in Colony, laid on Table, 496	6	809
<b>MR. L. C. JENKINS, LATE DRIVER :—</b>		
Correspondence respecting, laid on Table, 505. (Not printed.)		
<b>MURRUMBURRAH PLATFORM :—</b>		
Motion made ( <i>Mr. Gordon</i> ) for return showing goods and passenger traffic, revenue, and expenditure at, 295; Return to Order, laid on Table, 338	6	739
<b>MUSWELLBROOK-CASSILIS RAILWAY LINE :—</b>		
Motion made ( <i>Mr. Fitzgerald</i> ) for plans and papers connected with, 519.		
<b>NARRABRI TO WALGETT :—</b>		
Motion made ( <i>Mr. Dangar</i> ) for copy of final survey of route, with plan and reports, showing distance, characteristics of country, cost, &c., 41; Return to Order laid on Table, 174	6	993
Motion made ( <i>Mr. Dangar</i> ) for cheap line of Railway, and by leave withdrawn, 369.		
<b>NARRABRI STATION :—</b>		
Return of Traffic to and from, from 1st January to 31st October, 1887, laid on Table, 231	6	737
Return of Traffic to and from, for 1886 and 1887, showing increase for 1887, laid on Table, 338	6	735



REFERENCES TO THE VOTES AND PROCEEDINGS, VOL. I—13TH PARLIAMENT—SESSION, 1887-8.	PAPERS.	
	VOI.	PAGE.
<b>R</b>		
<b>RAILWAYS—(continued) :—</b>		
<b>NARRABRI TO MOREE :—</b>		
Motion made ( <i>Mr. Hassall</i> ) that any scheme of railway proposals should include the already proposed line, and withdrawn, 238.		
<b>OCCUPATION OF COMPARTMENTS BY MS. L.A. :—</b>		
Motion made ( <i>Mr. McElhone</i> ) for adjournment of the House in reference to, 378.		
<b>O'ROURKE AND MCSHARRY v. THE COMMISSIONER :—</b>		
Paper in connection with the case, laid on Table, 50.....	6	699
Motion made ( <i>Mr. Lyne</i> ) for all papers, correspondence, &c., including arbitrators award (exclusive of evidence) in the case of, 130.		
<b>ORANGE TO MOLONG, BATHURST TO BOURKE, AND THE MUDGEE LINE :—</b>		
Motion made ( <i>Dr. Ross</i> ) for return of the expenditure at, and the number of passengers to and from the various stations, the amount received at each, and the number of men employed, 258 ; Return to Order laid on Table, 608.....	6	755
<b>OSBIC-STREET, GUNNEDAH :—</b>		
Motion made ( <i>Mr. Goodwin</i> ) for all correspondence, reports, plans, &c., respecting flooding of, by a railway drain, 22 ; Return to Order laid on Table, 122 .....	6	1077
<b>RAILWAY POLICY OF THE GOVERNMENT :—</b>		
Ministerial statement made by Sir Henry Parkes on, 501, 641.		
Adjournment moved ( <i>Mr. Moore</i> ) for the purpose of discussing, 513.		
<b>RAILWAY LABOURERS ON BLATNEY AND COWRA LINE :—</b>		
Motion made ( <i>Mr. Jeanneret</i> ) for adjournment of the House to bring under notice the condition of, and matters of urgent public importance in connection therewith, 325.		
<b>REBATES ALLOWED BY DEPARTMENT :—</b>		
Return of, during years 1883-4-5-6, laid on Table, 22.....	6	751
<b>REFRESHMENT-ROOMS :—</b>		
Return to Order ( <i>Session</i> , 1885-6) laid on Table, 403 .....	6	653
<b>REMOVAL OF ENGINE-SHEDS FROM DUBBO TO WELLINGTON :—</b>		
Motion made ( <i>Mr. Kelly</i> ) for Select Committee to inquire into and report upon, 233.		
<b>RESUMPTION OF EDWARD IRBY'S LAND AT BLUFF RIVER :—</b>		
Motion made ( <i>Mr. Lee</i> ) for a Select Committee to inquire into all circumstances attending, on the extension from Glen Innes to Tenterfield, 147 ; Return to Order ( <i>Second Session</i> , 1887) referred to Select Committee, 424 ; Mr. Thompson's name discharged from Select Committee, 432.		
Petition from Edward Irby to be represented before Select Committee, presented and prayer granted, 476. ....	6	813
<b>SILVER ORE :—</b>		
Return respecting, carried on, laid on Table, 635 .....	6	749
<b>SLEEPING BERTH—NASH v. COPELAND :—</b>		
Return to Order ( <i>Second Session</i> , 1887) laid on Table, 122 .....	6	701
<b>STATIONS BETWEEN SYDNEY AND HURSTVILLE :—</b>		
Return of passenger traffic at each station, to and from, for six months ended 30th September, 1887, laid on Table, 165 .....	6	729
<b>ST. LEONARDS TO PEARCE'S CORNER :—</b>		
Motion made ( <i>Mr. Trickett</i> ) for all claims, letters, &c., in reference to any claims for compensation in respect of any lands or improvements thereon, on the line, with official reports or valuations, 168.		
<b>ST. PETER'S—LIVERPOOL :—</b>		
Petition praying early construction of, presented, 59, 76. ....	6	1029, 1031
<b>SUBURBAN TRAFFIC :—</b>		
Return showing for four Sundays, of November, 1887, laid on Table, 341 .....	6	731
<b>SUPPLY OF COAL ON GREAT NORTHERN :—</b>		
Motion made ( <i>Mr. McElhone</i> ) for papers, &c., in reference to contracts of Messrs Reid and Longworth, and offer of Mr. Nowland at lower price, 352 ; Return to Order, laid on Table, 505 ...	6	673
<b>SYDNEY TO FORBES, VIA MOLONG, BORENORE TO FORBES, COMING TO FORBES, WOODSTOCK TO FORBES, AND COWRA TO FORBES :—</b>		
Return respecting, laid on Table, 524.....	8	1027
<b>THE CASE OF DANIEL CORKERY :—</b>		
Motion made ( <i>Mr. Lyne</i> ) for all reports, papers, &c., in connection with the suspension, dismissal, and reinstatement of, as Locomotive Engineer in Department, 147 ; Return to Order laid on Table, 302 .....	6	633
<b>THROUGH TICKETS—SYDNEY TO BRISBANE :—</b>		
Information respecting, laid on Table, 302 .....	6	725
<b>TICKET COLLECTOR EDWARD COOLE :—</b>		
Information respecting, laid on Table, 302 .....	6	643
<b>TRAFFIC INSPECTORS ROBERTS AND CRAWFORD :—</b>		
Motion made ( <i>Mr. Lyne</i> ) for all papers, applications, &c., in reference to salary and house allowance to, 241 ; Return to Order laid on Table, 277 .....	6	627
<b>WAGGA WAGGA TO TUMBERUMBA AND THE UPPER MURRAY :—</b>		
Motion made ( <i>Mr. Lyne</i> ) that any scheme of railway proposals should include a line from, and withdrawn, 238.		
<b>WHITTINGHAM PLATFORM :—</b>		
Motion made ( <i>Mr. Gould</i> ) for all correspondence, petitions, &c., in reference to additional accommodation at, 155 ; Return to Order laid on Table, 252.....	6	1093
<b>WORKSHOPS AND SHEDS AT BATHURST :—</b>		
Motion made ( <i>Mr. Cortis</i> ) for adjournment of the House to consider removal of men from, and answers given by Minister in the House, 328.		
<b>YOUNG TO DUBBO :—</b>		
Petition certain inhabitants of Grenfell in favour of, presented, 476. ....	6	1037
Do do Parkes do 476. ....	6	1037
Do do town and district of Young in favour of, presented and read by Clerk, 496. ....	6	1039
<b>REAL PROPERTY ACT :—</b>		
<b>EXAMINERS OF TITLES UNDER :—</b>		
Motion made ( <i>Mr. J. P. Abbott</i> ) for a return showing work dealt with by Mr. Burton and the other Examiners, 70 ; Return to Order laid on Table, 112.....	2	1017
Annual Returns under, for 1887, 578.....	8	1261
<b>REBATES (See "RAILWAYS").</b>		
<b>RECLAMATION OF NEUTRAL BAY AND CAREENING COVE :—</b>		
Petition of Residents and Ratepayers on the North Shore, presented, 273. ....	3	893

REFERENCES TO THE VOTES AND PROCEEDINGS, VOL. I—13TH PARLIAMENT—SESSION, 1887-8.		PAPERS.	
		VOL.	PAGE.
<b>R</b>			
RECOMMITTAL OF BILLS.—			
Passed, 98, 152, 201, 373, 507, 548, 586.			
Negatived, 507, 586, 595.			
RECORDS OF HOUSE:—			
Retention of, from the custody of the Clerk, reported by Mr. Speaker, 51; motion of <i>privilege</i> moved in reference to, records returned, and motion withdrawn, 53.			
Entry expunged from Votes and Proceedings, 90.			
RECREATION RESERVES (See also "RESERVES"):—			
Return showing subsidies from the year 1880 to 1887 inclusive laid on Table, 524	5		807
DIXON'S BAY, BONDI:—			
Return respecting occupation of, by the Bondi Aquarium Company, laid on Table, 553	5		799
REDFERN AND DARLING HARBOUR STATIONS (See "RAILWAYS").			
REDHEAD COAL-MINE RAILWAY ACT AMENDMENT BILL:—			
Petition presented ( <i>Mr. Day</i> ) for leave to bring in, 228; leave given, presented, and read 1 <sup>o</sup> , 231; referred to Select Committee, 236; Report brought up, 277; read 2 <sup>o</sup> , committed, reported, report adopted, 321; read 3 <sup>o</sup> , passed, and sent to Council, 325; returned with amendments, 390; Amendments agreed to, 463; Message to Council, 464; assent reported, 492.	2		1071
REFORMATORY FOR BOYS:—			
Motion made ( <i>Mr. Foster</i> ) that the establishment of, is a matter of urgent necessity, 89.			
REFRESHMENT COMMITTEE:—			
Sessional Order passed, 11.			
Name added to, 89.			
Report in reference to removal of notices exhibited in refreshment room, brought up, 505.			
REFRESHMENT-ROOMS (See "RAILWAYS").			
REGAN DANIEL (See "CROWN LANDS").			
REGINA v. CHRISTENSON (See "ADMINISTRATION OF JUSTICE").			
REGINA v. PRUEN (See "ADMINISTRATION OF JUSTICE").			
REGISTERED MEDICAL PRACTITIONERS' BILL.—			
Motion made ( <i>Mr. Cortis</i> ) for Committee of the Whole, 88; House in Committee, and Resolution agreed to, 107; presented and read 1 <sup>o</sup> , 108; motion made for 2 <sup>o</sup> , and objection taken that Order of Leave is exceeded sustained, and Bill withdrawn, 192.			
REGISTERED MEDICAL PRACTITIONERS BILL (No. 2):—			
Motion made ( <i>Mr. Cortis</i> ) for Committee of the Whole, 219; Order of the Day postponed, 252; Motion made for House to go into Committee, and House counted out, 321; Order of the Day restored, 404; motion for 2 <sup>o</sup> negatived, 508.			
REGISTRAR-GENERAL (See "CIVIL SERVICE").			
REGISTRATIONS OF INVENTIONS.—			
Letters of, for 1883, laid on Table, 191, 420	{ 9		1
	{ 10		1
REGULATIONS:—			
LAID ON TABLE:—			
Amendment of Timber State Forest and Quarry, 360	5		595
Beer Duty Act, 35	3		883
Commons Acts of 1873 and 1886, 6	5		825
Crown Lands Act of 1884, 40, 155, 267, 429	5		581, 583, 591, 597
Do do Further amendment of Schedule of Classes of Fencing, 40, 199, 613	5		585, 587, 589
Do do Notification of cancellation, 360	5		595
Do do Amendment to No. 111, 302	5		593
Customs Regulation Act of 1879 and Customs Duties Act of 1887, 208	3		865
Electric Telegraph Act, 35, 608	4		1161, 1165
Fire Brigades Act, 6, 578, 634	2		611, 613, 617
Imported Stock Acts, 6 (2), 524	8		637, 639, 641
Industrial School for Girls, Parramatta, 155	4		521
Public Instruction Act, 6 (2)	4		517, 519
Volunteer Force Regulation Act, 6, 257	2		37, 39
Diseases in Sheep and Imported Stock Acts, 257	8		651
Patents' Office, 257, 378	8		1241, 1245
Bankruptcy Act of 1887, 451	2		731
Mining Act Further Amendment Act of 1884, Mining Leases, 492	8		539
REID AND LONGWORTH (See "RAILWAYS").			
REID, WILLIAM JAMES (See "CROWN LANDS BILL No. 2").			
RELIEF TO POOR OF SYDNEY.—			
Information respecting, during Centennial Week, 302	8		1031
RELIGION (See "STATISTICS").			
RELIGIOUS PURPOSES (See "CROWN LANDS").			
REMOVAL OF TIMBER FROM CROWN LANDS NEAR CLARENCETOWN.—			
Motion made ( <i>Mr. Creer</i> ) for Papers, 335: Return to Order laid on Table, 385	5		499
RENHAM, MICHAEL CHARLES (See "CROWN LANDS").			
RENTS (See "CROWN LANDS"; also "DISTRESS FOR RENT ABOLITION BILL"; also "PREFERENTIAL CLAIMS FOR RENT BILL").			
REPAYMENT OF LOANS BILL:—			
Ordered ( <i>Mr. Burns</i> ), founded on Resolution of Ways and Means No. 12, presented and read 1 <sup>o</sup> , 628; read 2 <sup>o</sup> ; committed, reported, report adopted, read 3 <sup>o</sup> ; passed, 639; sent to Council, 640; returned without amendment, 642; assented to in Council Chamber, 642.			
REPLY, RIGHT OF (See "STANDING ORDERS").			
REPORTS:—			
LAID ON TABLE:—			
Auditor-General's, on Receipts and Expenditure for 1886, 2	3		509
Do do do for 1887, 563	3		657
Railways and Tramways of New South Wales for 1886, 6	6		1
Do do do for 1887, 635	6		225
Intoxicating Drink Inquiry Commission, with Minutes of Evidence and Appendices (First Part), 6	7		1
Stock Branch Department of Mines for 1886, 6	8		543
Stock and Brands Branch, Department of Mines, for the year 1887, 408	8		573
Thirty-second Annual, of Postmaster-General, being for 1886, 6	4		783
Postmaster-General, Thirty-third Annual, being for 1887, 635	4		881
Technical Education, by Edward Combes, C.M.G., 28	4		229
Public Charities for 1886, 52	4		691
Changes in Penal Administration of the Colony, 52	4		1213
Government Asylums Inquiry Board—Reports, &c., from Manager, Matrons, Superintendents, and others, on, 82	4		617
Forest Branch, Department of Mines, 97	5		765

REFERENCES TO THE VOTES AND PROCEEDINGS, VOL. I—13TH PARLIAMENT—SESSION, 1887-8.		PAPERS.	
		VOL.	PAGE.
<b>R</b>			
<b>REPORTS—(continued):—</b>			
<b>LAI'D ON TABLE (continued):—</b>			
Railway Accident to Express Goods Train at Petersham Bridge, by Wm. Cruickshank, M.I.C.E., 103.	6	617	
City of Sydney Improvement Board for 1886-7, 112	2	269	
Theatres and other Public Places of Amusement, 128	8	1209	
Board on Competitive Designs for State House, 196	8	1279	
Major-General Schaw on Defences of New South Wales, 199	2	47	
Fisheries of the Colony by the Commissioners, to 31st December, 1886, 223	8	1069	
Police Department for 1887, 257	4	1203	
Creation, Inscription, and Issue of Stock, under Inscribed Stock Act of 1883, 257	3	505	
Department of Lands for 1880, 257	5	1	
Mr. G. H. Stayton, M. Inst. C.E., on Sewerage and Drainage of the Western Suburbs, 267; plan to be appended, 613	5	895	
Examiner of Coal-fields in connection with charges made against him in Legislative Assembly, 273	8	217	
Sydney Grammar School, for 1886, 285	4	573	
Do do 1887, 432	4	581	
Nautical School Ship Vernon, 1887, 285	4	683	
Goulburn Fire Brigade Board, 1887, 302	2	609	
Extension of Channel, and Improvements to Wharf at Moama, 302	3	1039	
Superintendent of Drills on the Boring Operations on the 101½-mile, Bourke to Wanaaring Road, 302	8	953	
Sir John Coode's, on Lake Macquarie Harbour Works, 324	3	895	
Do Entrance to Richmond River, 462	3	905	
Do Entrance to Clarence River, 475	3	899	
Board of Health on Proposals to effect Destruction of Rabbits by means of Diseases, 335	8	955	
Do Typhoid Fever at Coast Hospital, 608	2	235	
Typhoid Fever in Sydney and Suburbs, from 1876 to 1888, 543	2	231	
Immigration Agent, for 1887, 352	2	159	
Metropolitan Fire Brigades Board, for 1887, under the Fire Brigades Act of 1884, 378	2	571	
Trustees of the Sydney Free Public Library, for 1887-8, 378	4	581	
Annual of the Department of Mines, for 1887, 378	8	1	
Minister of Public Instruction on Education, for 1887, laid on Table, 408; Annex XVII to, 425	4	1	
Annual, on Prisons for 1887, 420	4	1223	
Annual, on Military Forces of the Colony for 1887, 425	2	1	
Inspector-General of the Insane for 1887, 429	4	635	
Deniliquin Fire Brigades Board for 1887-8, 462	2	605	
Annual, of the Civil Service Board for 1887, 475	2	69	
Annual, Board for the Protection of the Aborigines, 475	4	687	
Fatal Accident to John Mansfield at the Northumberland Colliery, 475	8	249	
Fatal Accident to Edward M'Carran at the West Wallsend Colliery, 475	8	259	
Coast Hospital, Little Bay, for 1887, 479	4	599	
Vaccination, for 1887, 479	2	229	
University of Sydney for 1887, 524	4	547	
Prospect Dam, Messrs. Bishop, Whitton, and Bennett, C.E.s, 529	5	849	
Board appointed to inquire into Kenny Hill and Pott's Hill Reservoir Scheme, 547	5	853	
President of the New South Wales Commission on the Adelaide Jubilee International Exhibition, 1887, 565	8	985	
State Children's Relief Department, for year ended 5th April, 1888, 565	4	753	
<b>STANDING ORDERS COMMITTEE:—</b>			
Proposed new, 476	1	845	
<b>FROM ELECTIONS AND QUALIFICATIONS COMMITTEE:—</b>			
Seat of the Honorable Bernhard Ringrose Wise, Esquire, South Sydney, 55	1	903	
Election Petition—Hellmrich v. W. J. Allen, Paddington, 296	1	891	
<b>REFRESHMENT COMMITTEE:—</b>			
Removal of Notices, 505	1	887	
<b>FROM SELECT COMMITTEES:—</b>			
Pharmaceutical Society of New South Wales Incorporation Bill, 76	2	1061	
Church and Perkins Streets (Newcastle) Bill, 76	2	891	
North Shore, Manly, and Pittwater Tramway and Railway Bill, 89	2	1011	
Yass Roman Catholic Church Land Sale Bill, 99	2	1215	
Claim of Mrs. Butterley, 140	6	647	
Leichhardt Council Chambers (Mortgage) Bill, 145	2	957	
Broken Hill Tramway Bill, 200, 302	2	825	
Thomas Thompson's conditional purchase, made at Moama, 200	5	207	
Victorian Coal-mining Company's Extension Bill, 201	2	1201	
Grafton School of Arts Trustees Enabling Bill, 224	2	919	
Christian Chapel Lands Sale Bill, 224	2	883	
Claims of Captain Rossi, 263	2	143	
Redhead Coal-mine Railway Act Amending Bill, 277	2	1071	
Purchase by the Government of Land adjoining the Australasian Steam Navigation Company's Wharf, 305	3	917	
St. Saviour's, Glebe, Land Leasing Bill, 314	2	1079	
Robert Mackrell's Conditional Purchase at Forbes, 342	5	285	
Parramatta Municipal Quarries Bill, 348	2	1055	
Parramatta, Church-street, Amended Alignment Bill, 348	2	1049	
Silverton Tramway Act Amending Bill, 348	2	1089	
Sydney Hydraulic Power Company's Bill, 349	2	1129	
Oakey Park Coal-mining Company's Railway Bill, 353	2	1029	
Oakey Park Coal-mining Company's Railway Bill (Second), 519	2	1037	
Kiama Tramway Act Amendment Bill, 369	2	951	
Liverpool Church of England Grammar School Land Sale Bill, 409	2	965	
Petition of George Matcham Pitt, junior, 416	5	485	
Hunter-street, Newcastle, Extension Bill, 429	2	925	
Broken Hill and Suburban Gas Company's Bill, 429	2	817	
Sydney and Suburban Electric Lighting Bill, 454	2	1099	
North Shore Boroughs Wharves Bill, 463	2	971	
Crown Lands Purchases Validation Bill, 468	5	509	
Parry's Conditional Purchases on Currugundi and Warren South Runs, 487	5	239	
Mrs. Ann Rouse's Conditional Purchase at Kahibah, 496	5	265	
Sydney and Suburban Hydraulic Power Company's Bill, 496	2	1185	
West Maitland Cattle Sale Yards Bill, 519	2	1207	

REFERENCES TO THE VOTES AND PROCEEDINGS, VOL. I—13TH PARLIAMENT—SESSION, 1887-8.		PAPERS.	
	VOL.	PAGE.	
<b>R</b>			
REPORTS—(continued) :—			
FROM SELECT COMMITTEES—(continued) :—			
Goulburn and Tuena Tramway Bill, 523.....	2	907	
Broken Hill Water Supply Bill, 537.....	2	863	
Cooma Church of England Lands Sale Bill, 547.....	2	901	
Mineral Conditional Purchases, parish of Metz, 572.....	8	439	
Messrs. Hugh McNeill and party's Mineral Lease at Captain's Flat, 592.....	8	491	
Claim of Isaac Barclay, 609.....	5	487	
Combination Trucks, 626.....	6	815	
RESERVES (See also "MINING"; also "WATER SUPPLY"; also "RECREATION RESERVES").			
RESOLUTIONS (See also "FINANCE").			
FROM COMMITTEE OF THE WHOLE :—			
Reported, 29 <sup>(3)</sup> , 42 <sup>(2)</sup> , 49, 70, 107 <sup>(2)</sup> , 108, 114, 115, 123, 161, 166 <sup>(2)</sup> , 193, 201 <sup>(2)</sup> , 253, 259, 321 <sup>(2)</sup> , 335, 365, 386, 455, 494, 543, 561, 580, 602.			
Agreed to, 29 <sup>(3)</sup> , 42 <sup>(2)</sup> , 49, 70, 107 <sup>(2)</sup> , 108, 114, 115, 123, 162, 166 <sup>(2)</sup> , 193, 201 <sup>(2)</sup> , 253, 259, 321 <sup>(2)</sup> , 335, 366, 455, 494, 544, 561, 580, 602.			
FROM COMMITTEE OF SUPPLY :—			
Reported, 201, 242, 295, 345, 409, 480, 553, 619.			
Agreed to, 201, 242, 295, 345, 409, 480, 553, 625.			
FROM COMMITTEE OF WAYS AND MEANS :—			
Reported, 242, 248, 295, 346, 409, 430, 554, 627.			
Received, 346, 409, 430, 554, 627.			
Agreed to, 242, 248, 295, 346, 409, 430, 554, 627.			
RESUMPTION OF LAND (See also "EDUCATION"; also "RAILWAYS").			
NOTIFICATIONS OF, LAID ON TABLE :—			
Water Supply purposes, 5, 165, 613.....	5	871, 873, 875	
Military Road, South Head to Ben Buckler and Bondi, 22.....	2	65	
Road along Main Sewer to Bondi, Old South Head Road to Forts, Bondi, 22.....	5	1019	
Public School purposes, 70, 155, 246, 257, 341, 360, 408, 496, 553, 608.....	4	525 to 545	
Extension of Parramatta Gaol, 231.....	4	1227	
Public Cemetery at Singleton, 252.....	8	1223	
Under 6th section of 44 Victoria No. 16, 314.....	5	683	
Daysdale Tank, 415.....	8	951	
Public wharf near Frederickton, Macleay River, 432.....	3	1049	
Wharf, &c., near Ghinny Ghinny, Manning River, 475.....	3	1051	
Sydney Sewerage Works, 613.....	5	877	
RETIREMENT OF MR. JONES (See "CLERK OF LEGISLATIVE ASSEMBLY").			
RETIRING ALLOWANCES (See "CIVIL SERVICE").			
REVENUE (See also "FINANCE") :—			
FROM ELECTORATES OF GRAFTON AND THE CLARENCE :—			
Motion made ( <i>Mr. See</i> ) for a Return showing, since 1861, 128.			
REVENUE RECEIPTS AND EXPENDITURE :—			
Abstracts of, for quarter ended 30th June, 1888, laid on Table, 561 (not printed).			
RICHARDSON JOSEPH, CLAIM OF (See "ROADS").			
RICHMOND RIVER (See also "PARLIAMENTARY STANDING COMMITTEE ON PUBLIC WORKS") :—			
EXPENDITURE ON ROADS AND BRIDGES, AND TOTAL REVENUE FROM DISTRICT :—			
Return ( <i>in part</i> ) to Order ( <i>Second Session</i> , 1887) laid on Table, 28.....	5	1023	
STEAM TUGS FOR :—			
Conditions respecting the Employment of, laid on Table, 165.....	3	1065	
Report by Sir John Cooce on the Entrance to, laid on Table, 462.....	3	905	
NOXIOUS WEEDS :—			
Motion made ( <i>Mr. Ewing</i> ) for report and papers in connection with, 546; Return to Order, laid on Table, 578.....	8	983	
RINGBARKING ON CROWN LANDS :—			
Motion made ( <i>Dr. Ross</i> ) for Return showing area and list of runs on which permission has been granted for, 325; Return to Order, laid on Table, 613.....	5	507	
ROADS (See also "MUNICIPAL ROADS AND STREETS BILL"; also "WHALING ROAD") :—			
ADDITIONAL VOTE OF £100,000 :—			
Return respecting the Expenditure of, laid on Table, 6.....	5	965	
MILITARY, FORTIFICATIONS AT SOUTH HEAD TO BEN BUCKLER AND FORTS NEAR BONDI :—			
Notification under Lands for Public Purposes Acquisition Act for resumption of land for, laid on Table, 22.....	2	65	
ALONG MAIN SEWER, BONDI, AND TO CONNECT OLD SOUTH HEAD WITH FORTS AT BONDI :—			
Notification under Lands for Public Purposes Acquisition Act for resumption of land for, laid on Table, 22.....	5	1019	
COOMA TO BOMBALA :—			
Motion made ( <i>Mr. Dawson</i> ) for a return of money expended on, from 1877 to 1887, 22; Return to Order, laid on Table, 58.....	5	993	
AND BRIDGES IN THE ELECTORATE OF THE RICHMOND :—			
Return ( <i>in part</i> ) to Order ( <i>Second Session</i> , 1887), laid on Table, 28.....	5	1023	
CLAIM OF JOSEPH RICHARDSON AGAINST THE DEPARTMENT :—			
Motion made ( <i>Mr. Wall</i> ) for a Select Committee to inquire into, 36.			
MESSRS. LEONARD AND BATHGATE'S CANCELLED CONTRACTS :—			
Motion made ( <i>Mr. Stokes</i> ) for all correspondence, reports, minutes, &c., reference to, 103; Return to Order laid on Table, 231.....	5	995	
PARISH :—			
Motion made ( <i>Mr. O'Sullivan</i> ) for a return showing those which have been asked to be opened which are still kept closed, and where situated, 168.			
AUBURN PARK TRUST :—			
Motion made ( <i>Mr. Frank Farnell</i> ) for all papers and minutes in connection with, 196; Return to Order, laid on Table, 341.....	5	997	
SUBORDINATE :—			
Schedule showing classification and proposed distribution of Vote for 1883, under Officers of the Department, laid on Table, 224.....	5	949	
Schedule, showing classification and proposed distribution of Vote for 1883, under Trustees, laid on Table, 224.....	5	943	
VOTE OF £25,000 ON ESTIMATES FOR 1888 :—			
Schedule showing distribution, laid on Table, 224.....	5	969	

REFERENCES TO THE VOTES AND PROCEEDINGS, VOL. I—13TH PARLIAMENT—SESSION, 1887-8.		PAPERS.	
		VOL.	PAGE.
<b>R</b>			
ROADS—(continued):—			
TULCUMBA TO GUNNEDAH:—			
Motion made ( <i>Mr. J. P. Abbott</i> ) for papers, &c., 288; Return to Order, laid on Table, 537 .....	5		987
GLENTHORNE AND PURELEET, MANNING RIVER:—			
Motion made ( <i>Mr. Sydney Smith</i> ) for papers having reference to, 437; Return to Order, laid on Table, 524.....	5		973
Trust Accounts for the half-year ending 30 June and 31 December, 1887, laid on Table, 505 .....	5		937
GRANTS WITHIN MUNICIPAL BOUNDARIES:—			
Return respecting, laid on Table, 635 .....	2		271
ROBERTSON, MR. THOMAS:—			
Letter from, read by Mr. Speaker, apologizing for having interrupted the Proceedings of the House, and apology accepted, 79.			
ROBERTSON (See "RAILWAYS").			
ROBERTS, RAILWAY TRAFFIC INSPECTOR (See "RAILWAYS").			
ROCKDALE MUNICIPALITY NAMING BILL:—			
Motion made ( <i>Mr. Carruthers</i> ) for leave to bring in, presented and read, 1 <sup>o</sup> , 103; read 2 <sup>o</sup> , committed, reported without amendment, and report adopted, 192; read 3 <sup>o</sup> , passed and sent to Council, 208; returned with amendments, 264; Council's amendments agreed to, Message to Council, 417; assent reported, 462.			
ROGERS ALEXANDER (See "CROWN LANDS PURCHASES VALIDATION BILL").			
ROLLS (See "ELECTORAL").			
ROSEHILL RACECOURSE (See "TELEGRAPHS").			
ROSS, WILLIAM (See "NATIONAL PARK").			
ROSSI, CAPTAIN:—			
CLAIMS OF:—			
Motion made ( <i>Mr. Hurley</i> ) for a Select Committee to consider, 36; Return to Address ( <i>Session</i> , 1883-4) referred, 184; Report brought up, 263; Motion made ( <i>Mr. Hurley</i> ) for adoption of Report, and the Question not being put at 7 o'clock, Government Business takes precedence, 560.	2		143
Petition presented from, asking leave to be heard before the Bar of the House or the Select Committee, in opposition to the Church of England Property Bill, 538 .....	2		897
Petition presented in reference to St. Saviour's Glebe Land Leasing Bill, 246.....	2		1087
ROUSE, MRS. ANN (See "CROWN LANDS").			
ROYALTY ON OYSTERS ABOLITION BILL:—			
Motion made ( <i>Sir Henry Parkes</i> ) for leave to bring in, 140; presented and read 1 <sup>o</sup> , 140; read 2 <sup>o</sup> , committed, reported without amendment, and report adopted, 166; read 3 <sup>o</sup> , passed and sent to Council, 169; returned without amendment, 197; Assent reported, 219.			
RULES:—			
Under Volunteer Force Regulation Act, of 5th Regiment Scottish Rifles, laid on Table, 6.....	2		39
Supreme Court, laid on Table, 257, 635 .....	2		709, 711
Bankruptcy Act, laid on Table, 267.....	2		727
RULINGS OF SPEAKER (See also "SPEAKER"):—			
On Points of Order arising in the House, 4, 24, 42, 49, 156, 192, 224, 252, 259, 315, 426, 433, 455, 574, 587, 599, 635.			
Dissent from, moved and withdrawn 49.			
Do. moved and negatived, 4, 24, 25, 156-7, 565.			
RUSHCUTTERS BAY ACT AMENDMENT BILL:—			
Motion made ( <i>Mr. J. P. Abbott</i> ) for leave to bring in, 287; presented and read 1 <sup>o</sup> , 356; Order of the Day discharged and Bill withdrawn, 508.			
<b>S</b>			
SAINT JAMES' PARSONAGE LAND LEASING BILL:—			
Assent reported ( <i>passed in the last Session</i> ), 2.			
SAINT SAVIOUR'S GLEBE LAND LEASING BILL:—			
Petition presented ( <i>Mr. Colls</i> ) for leave to bring in, 237; leave given, presented, and read 1 <sup>o</sup> , 241; referred to Select Committee, 246; Report brought up, 314 .....	2		1079
Petition from F. R. I. Rossi, Trustee, in opposition to the passing of the Bill, presented, 246 .....	2		1087
SALARIES OF CIVIL SERVANTS (See "CIVIL SERVICE").			
SAND-DRIFT (See "NEWCASTLE SAND-DRIFT RECLAMATION ACT REPEAL BILL").			
SANKEY, PATRICK, THE CASE OF:—			
Return to Order ( <i>Session</i> , 1887) laid on Table (not printed), 304.			
SAVAGE, CAPTAIN A. H. P. (See "MILITARY").			
SAVAGE, THE MISSES:—			
Petition presented in reference to claim for services by their late father, and praying the House to take their case into favourable consideration, and read by the Clerk, 565 .....	8		1295
SAVINGS BANK, GOVERNMENT:—			
Statement of accounts for 1887, 356.....	3		819
SCHAW, MAJOR-GENERAL (See "MILITARY").			
SCHEDULE:—			
Showing classification and proposed distribution of Vote for 1888, for subordinate roads under the officers of the Department, laid on Table, 224 .....	5		949
Showing classification and proposed distribution of Vote for 1888, for subordinate roads under Trustees, laid on Table, 224 .....	5		943
Showing proposed distribution of Vote of £55,000 on Estimates for 1888 for Bridges, laid on Table, 224.....	5		965
Showing proposed distribution of Vote of £25,000 for 1888 for Roads, laid on Table, 224 .....	5		963
To Estimates-in-Chief, for 1888, showing the total remuneration received by all Public Officers, laid on Table, 228 .....	3		153
SCHOOL ATTENDANCE OFFICERS (See "EDUCATION").			
SCHOOLS (See "EDUCATION," also "CHURCH AND SCHOOL LANDS MINING BILL").			
SEAVER, JONATHAN C. B. P., Esq., M.P.:—			
Leave of absence granted to, 361.			
SEDUCTION PUNISHMENT BILL:—			
Motion made ( <i>Mr. J. S. Farnell</i> ) for leave to bring in, presented, and read 1 <sup>o</sup> , 40; Order of the Day postponed, 77, 107, 145, 169, 192, 224; read 2 <sup>o</sup> and committed, 253; Order of the Day postponed, 285; further considered in Committee and reported with amendments, report adopted, 321; Order of the Day postponed, 484.			

REFERENCES TO THE VOTES AND PROCEEDINGS, VOL. I—13TH PARLIAMENT—SESSION, 1887-8.	PAPERS.
	VOL. PAGE.
<b>S</b>	
<b>SELECT COMMITTEES</b> (See also "REPORTS") :—	
Appointed by ballot, 30.	
Authorized to make visits of inspection, 155, 287.	
Evidence, &c., of previous Session referred to, 115, 140.	
Leave granted to Clerk to return documents handed in before, 88, 468.	
Members name removed from, 432, 462.	
Do substituted for another on, 585.	
Papers referred to, 52, 161, 184, 424, 463.	
Petitions referred to, 40 (2), 122, 135, 165, 192, 215, 232, 324, 328, 341, 403, 491.	
Prayer of Petition granted to be heard in person or by Counsel before, 144, 150, 161, 181, 192, 208, 294.	
Proceedings and Evidence of ( <i>previous Session</i> ), laid on Table by Clerk, 71, 115, 140.	
Report from, referred back, 200.	
Sessional Order relative to balloting for, passed, 11.	
Vote of Chairman of, on Private Bills, Sessional Order passed, 11.	
Bill referred back to, 487.	
Motion made ( <i>Mr Barbour</i> ) for Committee of the Whole to consider the question of remuneration to Members attending on Private Bill Committees, 608.	
Abstract of Standing, appointed during the Session .....	1 831
<b>SELECTIONS</b> (See "CROWN LANDS").	
<b>SEMPILL</b> (See "DISTRIBUTION OF FUNDS IN SEMPILL'S ESTATES BILL").	
<b>SERGEANT-AT-ARMS</b> :—	
Motion made to commit Member adjudged guilty of contempt to custody of, 156; and withdrawn, 157.	
Removes Members from the Chamber, 220 (7), 221 (7), 345.	
Speaker's Warrant issued committing Member to custody of, 480.	
Member in custody of, 483.	
Member discharged from custody, 486.	
<b>SESSIONAL ORDERS</b> :—	
Passed 9, 10 (6), 11 (9), 12 (2), 89 (3), 103, 408.	
Hour of Meeting of the House, 224.	
Rescinded (Friday's sitting), 325.	
Precedence of Government Business on Tuesdays, 408.	
Friday Sitting Day, General Business to take precedence, 585; Monday Sitting Day, Government Business to take precedence, 585.	
<b>SEWERAGE</b> (See "WATER SUPPLY"; also "METROPOLITAN WATER AND SEWERAGE ACT AMENDMENT BILL"; also "COUNTRY TOWNS WATER AND SEWERAGE ACT EXTENSION BILL").	
Report of Mr. G. H. Stayton, M. Inst. C.E., on Western Suburbs, laid on Table, 267; Plan laid on Table ( <i>to be appended to Mr. Stayton's Report</i> ), 613; Sections of proposed Sewers ( <i>to be appended to Mr. Stayton's Report</i> ), laid on Table, 635.	5 895
<b>SYDNEY</b> :—	
Return respecting Contract for laying Cast-iron Syphon, George-street West, Contract No. 35, laid on Table, 608; Notification of resumption of land in connection with Works for, laid on Table, 613 .....	5 933
<b>SHAW, THOMAS</b> (See "CROWN LANDS BILL, No. 2").	
<b>SHEA, JEREMIAH</b> :—	
Petition from, that he was sent to the Colony in 1818, that he is now 88 years of age, that he discovered gold in the Northern Fields in 1852, but has received no acknowledgment for the same, and he is now through age and infirmity unable to earn his living, and praying relief, presented, 112 .....	8 1217
<b>SHEPHERD v. LEONARD</b> (See "ADMINISTRATION OF JUSTICE").	
<b>SHIPPING</b> (See "STATISTICS").	
<b>SHORT-HAND WRITING SERVICES</b> :—	
Motion made ( <i>Mr. Walker</i> ) for a return showing amount paid for, in connection with each Commission and Board of Inquiry since 1st January, 1886, also the number and name of Commissions and Boards of Inquiry attended by <i>Hansard Staff</i> , 232.	
<b>SICK POOR OF THE METROPOLIS</b> :—	
<b>ADDITIONAL ACCOMMODATION</b> :—	
Motion made ( <i>Mr. R. B. Wilkinson</i> ) for correspondence respecting, 493.	
<b>SILVER ORE</b> :—	
Return respecting, carried on Railway, laid on Table, 635 .....	6 749
<b>SILVERTON</b> (See "RAILWAYS").	
<b>SILVERTON TRAMWAY ACT AMENDING BILL</b> :—	
Standing Orders suspended, to admit of presentation of Petition to bring in, 294.	
Petition presented ( <i>Mr. Day</i> ) for leave to bring in, 295; leave given, presented, and read 1 <sup>o</sup> , 303; referred to Select Committee, 308; Report brought up, 348; read 2 <sup>o</sup> , committed, reported without amendment, report adopted, 421; read 3 <sup>o</sup> , passed and sent to Council, 425; returned with amendments, 593; Order of the Day postponed, 619; amendments agreed to, 641; assented to in Legislative Council Chamber, 642.	2 1089
Petition of Charles Bath to be heard by Counsel, Attorney, or Agent, before the Select Committee, presented, 341 .....	2 1097
<b>SIMPSON, THE HONORABLE G. B.</b> :—	
Acceptance of Office of Attorney-General by, 264.	
<b>SINGLETON</b> (See "CEMETERY").	
<b>SIXPENCES, DESIGN FOR COINING</b> (See "COINAGE").	
<b>SKENE, WILLIAM, PRELEASE OF, AT CONARGO</b> (See "CROWN LANDS").	
<b>SLATTERY, THOMAS MICHAEL, ESQUIRE, M.P.</b> :—	
Appointed Chairman of Committees for the day only, 70, 342, 344, 348.	
Declared guilty of persistent disorder and removed by Sergeant-at-Arms from the Chamber, 220.	
Appointed with three others to act temporarily as Chairman of Committees, in the absence of the Member appointed to that office, 339.	
Speaker calls on, to act as Deputy Chairman of Committees, for the day only, 408, 524.	
<b>PRIVILEGE—Slattery v. Young</b> :—	
Speaker reported receipt of letter from Mr. P. J. Hourigan, Solicitor, that, at instance of Mr. Slattery, he had issued a writ against him to recover damages for having caused Mr. Slattery to be removed from the Chamber; motion made ( <i>Sir Henry Parkes</i> ) that Mr. Speaker have leave to appear and plead, that Crown Solicitor accept service of the Writ, and that Attorney-General defend the action, 228.	
<b>SLEEPING BERTH</b> (See "RAILWAYS").	

REFERENCES TO THE VOTES AND PROCEEDINGS, VOL. I—13TH PARLIAMENT—SESSION, 1887—8.	PAPERS.	
	VOL.	PAGE.
<b>S</b>		
SMELTING WORKS (See "MINING").		
SMITH, MR. J. A., PUBLIC SCHOOL TEACHER AT COOLA CREEK (See "EDUCATION").		
SMITH, THE HONORABLE JOHN (See also "CROWN LANDS") :—		
LANDS HELD BY, IN DISTRICT OF MOLONG :—		
Motion made ( <i>Dr. Ross</i> ) for a return showing, under Orders in Council, the area of each portion, and why granted, 155; Return to Order laid on Table, 219 .....	5	445
SOUTH WARATAH COLLIERY (See "MINING").		
SPEAKER :—		
Names a member for disorderly conduct, 156 (2), 184.		
Declares Members guilty of persistent disorder, and directs the Sergeant-at-Arms to remove them from the Chamber, 220 (?), 221 (?).		
Directs removal of Member by Sergeant-at-Arms, 345.		
Reports resignation of Member, 1, 73, 222, 269, 419.		
Reports issue and return of Writ, 1, 73, 87, 249(3), 303, 339, 463.		
Acquaints House of receipt of telegram conveying special thanks of Her Most Gracious Majesty the Queen for the Address of Congratulation on the completion of the Jubilee Year of Her Reign, 2.		
Acquaints House of receipt of Message from the Governor assenting to Bill passed during previous Session, 2.		
Lays on Table Statement of Receipts and Expenditure for 1886, with Auditor-General's Report, 2	3	509
Lays on Table Statement of Receipts and Expenditure for 1887, with Auditor-General's Report, 563	3	657
Reports attendance of House in Council, and reads Governor's Opening Speech, 2.		
Presents Address in Reply to Governor's Opening Speech, and reports Answer thereto, 5.		
Reports receipt of Deputy Speaker's Commission to administer Oath, 19.		
Lays Warrant appointing Elections and Qualifications Committee upon Table, 17, 269; reports maturity, 37, 287; appoints first meeting of Committee, 53.		
Informs House that Clerk had been summoned, 89, 351.		
Informs House of irregularities at an election and issue of Proclamation curing same, 73.		
Reports letter from Mr. Thomas Robertson, apologising for having interrupted the Proceedings of the House, 79.		
Announces course intended to be followed in carrying out Resolution that Entry be expunged from Votes and Proceedings, 91.		
Instructed by Resolution as to course to be followed in carrying out Resolution that Entry in Votes and Proceedings be expunged, 91.		
Authorized to present Additional Standing Order to Governor for approval, 28.		
Reports Governor's approval of Additional Standing Order, 31.		
Reports receipt of letter from Clerk, reporting that a document laid on the Table had not been returned to his custody by a Member who had had the use of it, 51.		
Reports retirement of Stephen W. Jones, Esq., Clerk of Legislative Assembly, 250.		
Notice of Motion to rescind appointment of Mr. James Henry Young, 252.		
Lays on Table Election Petition, <i>Hellmrich v. W. J. Allen</i> , Paddington, 269.		
Calls on a Deputy Chairman of Committees to act for the day only, 397, 403, 408, 416, 420, 425, 429, 432, 437, 442, 451, 454, 463, 468, 476, 479, 484, 493, 496, 500, 506, 513, 519, 524, 532, 538, 543 (2), 547, 560, 565, 573.		
Issues Warrant committing Member to custody of Sergeant-at-Arms, 480.		
Vacates Chair when motion couched in terms personal to himself is to be discussed; resumes Chair, and motion proceeded with, 579.		
Motion made ( <i>Mr. Buchanan</i> ) setting forth the qualifications essential to the Chairman or Speaker, that the present occupant of the Chair is deficient in the knowledge essential in anyone holding the office, and that his frequent interference is the cause of much disorder, and negatived, 579.		
RULINGS OF :—		
Motion made to dissent from, and negatived, 4, 24, 49, 156, 565.		
That it is not in order, on the motion for the adoption of the Address in Reply, to speak of any private transactions between a Minister and any person outside, that the matter was not relevant, and that any charges should be made on a specific motion, 4.		
That, on the question "That the question be now put," when there are no voices for the Noes, and when the Chair is satisfied there are forty Members present, it is not necessary to take a division, 24.		
That the Albury Cattle Sale-yards Bill, notwithstanding that the Select Committee to whom it was referred had decided at one sitting against a motion to report the Bill with amendments to the House, was not out of order, 42, 43.		
That language reflecting on the Chief Commissioner of Insolvent Estates, now an Acting Judge of the Supreme Court, infringes the rules of Debate, 49.		
That a motion adjudging a Member ("named" by Mr. Speaker) guilty of contempt can be put from the Chair, notwithstanding that the question "That the Question be now put" has been put from the Chair and is undecided, 156.		
That Registered Medical Practitioners Bill contains provisions not authorized by the Order of Leave, 192.		
That to challenge the action of the Chair under cover of a Motion for Adjournment of the House would be out of order, 224.		
That Notice of Motion to rescind appointment of Speaker was not out of order, and that motion submitted "That no Resolution reflecting upon the Speaker be entered on Votes and Proceedings" could not be put as one of Privilege, 252.		
That the Public Works Bill did not contain provisions beyond the Order of Leave, 259.		
Discussing Bill in detail on second reading, 315.		
That Councils amendments in Government Railways Bill, do not infringe on Rights of Assembly, 426.		
That Estimates were properly before the House, notwithstanding the Salaries therein shown were lower than those provided by the Civil Service Act, 433.		
That Schedules A, B, and C on Estimates are not open to discussion, as they are already provided for by Acts of Parliament, 433.		
Declines to overrule the opinion of the Chairman in reference to words used by Mr. M'Elhone in Committee of Supply, 452.		
That clause 3, of Chinese Restriction and Regulation Bill was not beyond order of leave, 455.		
That amendment made in Land Tax Bill was in order, 587.		
That Church of England Property Bill, although introduced in the Council as a Private Bill, should, under the 69th Standing Order, be treated as a Public Bill in the Assembly, 599.		
That by a previous decision of the House he had been relieved of the responsibility of determining whether, on a motion of adjournment, the matter stated in the notice was of urgent public importance, and that the objection should have been taken before the question was stated, 635.		

REFERENCES TO THE VOTES AND PROCEEDINGS, VOL. I—13TH PARLIAMENT—SESSION, 1887-8.		PAPERS.	
S		VOL.	PAGE.
<b>SPEAKER—(continued):—</b>			
<b>PRIVILEGE:—</b>			
Acquaints House of receipt of letter from Mr. P. J. Hourigan, Solicitor, that at instance of Mr. Slattery, he had issued a Writ against Mr. Speaker, to recover damages for having caused Mr. Slattery to be removed from the Chamber; motion made ( <i>Sir Henry Parkes</i> ) that Mr. Speaker have leave to appear and plead, that Crown Solicitor accept service of Writ, and the Attorney-General defend the action, 228.			
<b>SPECIAL ADJOURNMENT:—</b>			
Motion made for, and passed, 1, 128, 216, 246, 232, 314, 353 ( <i>Easter</i> ), 456, 467 ( <i>Queen's Birthday</i> ).			
<b>SPECIAL AUDIT (See "MUNICIPAL").</b>			
<b>SPECIAL GRANTS TO MUNICIPALITIES:—</b>			
Motion made ( <i>Mr. Creer</i> ) for Committee of the Whole to consider an Address to the Governor for, 404; Order of the Day discharged, 508.			
<b>SPIRITS:—</b>			
<b>WINES AND BEER:—</b>			
Annual Return to Order, laid on Table, 560			
7		681	
<b>SPIT, MIDDLE HARBOUR (See "PARLIAMENTARY STANDING COMMITTEE ON PUBLIC WORKS").</b>			
<b>ST. LEONARDS (See also "NORTH SHORE BOROUGHES WHARVES BILL"; also "ELECTORAL"; also "RAILWAYS"; also "CROWN LANDS BILL No. 2"):</b>			
Proclamation, under the Public Parks Act of 1884, extinguishing, as a public highway, part of the Recreation Reserve, laid on Table, 6			
5		811	
<b>ST. PETER'S-LIVERPOOL LINE (See "RAILWAYS").</b>			
<b>ST. THOMAS CHURCH ENFIELD LANDS SALE BILL:—</b>			
Received from Legislative Council, and on motion ( <i>Mr. J. P. Abbott</i> ), read 1 <sup>o</sup> , 462; read 2 <sup>o</sup> , committed, reported without amendment, report adopted, 507; read 3 <sup>o</sup> , passed, returned to Council, 524; assent reported, 539.			
<b>STAFFORD WILLIAM, EX-SERGEANT OF POLICE:—</b>			
Motion made ( <i>Mr. O'Sullivan</i> ) for papers respecting dismissal of, 338; Return to Order laid on Table, 352			
4		1215	
Petition presented ( <i>Dr Ross</i> ) in reference to dismissal of 425			
4		1221	
<b>STAMP DUTIES ACT:—</b>			
<b>ALLEGED FRAUD UNDER:—</b>			
Motion made ( <i>Mr. O'Sullivan</i> ) for all papers, correspondence, &c., in the recent case of, in connection with certain land at Queanbeyan, 40; Return to Order, laid on Table, 174			
8		1265	
<b>STANDING ORDERS:—</b>			
65th entertained, to permit a Private Bill being taken up at the stage at which it was left in a previous Session, 9, 17, 22, 23, 35, 98.			
61st suspended, to admit of presentation of Petition for Private Bill, 294, 361.			
Suspension of, to enable Bill to pass through remaining stages in one day, 191.			
Do. do all stages in one day, 241, 295, 326, 314, 400, 455, 479, 553, 578.			
Motion made ( <i>Mr. Burns</i> ) that the suspension of certain, is a matter of urgent and pressing necessity, 241.			
Motion made ( <i>Sir Henry Parkes</i> ) to suspend, as a matter of urgency, to appoint a Chairman of Committees for the day only, 385.			
Motion made ( <i>Mr. J. P. Abbott</i> ) to refer the whole to Standing Orders Committee for consideration, revision, amendment, and report, and that Committee have leave to sit during adjournment or prorogation of the House, and amended ( <i>Mr. M'Millan</i> ) by omission of words giving leave to sit during adjournment and prorogation, 353; Report brought up, 476; ordered to be considered in Committee, 479; Order of the Day postponed, 529, 566, 592.			
1		849	
<b>STANDING AND SELECT COMMITTEES:—</b>			
Abstract of, appointed during the Session			
1		831	
<b>ADDITIONAL (RIGHT OF REPLY):—</b>			
Motion made ( <i>Mr. J. P. Abbott</i> ), that, whenever it shall have been decided that any Question shall be put, thereupon, and after it has been so decided, but before such Question be put, the mover of the matter pending shall be permitted to speak in reply under certain restrictions, 23; motion made ( <i>Mr. Abbott</i> ), authorizing Mr. Speaker to present to the Governor for approval, 28; approval reported, 31.			
<b>ADDITIONAL No. 5:—</b>			
Motion made ( <i>Mr. Moore</i> ) that Additional Standing Order No. 5, adopted and approved May, 1887, being in contravention of the 23rd section of the Constitution Act, is <i>ultra vires</i> , 128; and negatived, 129.			
<b>COMMITTEE:—</b>			
Sessional Order, passed, 11.			
Name added to, 89, 280.			
Standing Orders referred to, 353.			
<b>STANLEY, MR. (See "RABBIT PEST").</b>			
<b>STATE CHILDREN'S RELIEF DEPARTMENT:—</b>			
Report on, for year ended 5th April, 1888, laid on Table, 565			
4		753	
<b>STATE FORESTS AND FOREST RESERVES:—</b>			
Return of trees planted in, laid on Table, 273			
5		797	
Notification of amendment and cancellation of Regulations laid on Table, 360			
5		595	
<b>STATE HOUSE (See also "CENTENARY CELEBRATION ACT AMENDMENT BILL"):</b>			
Motion made ( <i>Mr. Dibbs</i> ) for Committee of the Whole to consider expediency of bringing in a Bill to appropriate the sum of £150,000, from the proceeds of sale of portion of the Centennial Park, for erection of a State House to be used as Houses of Parliament in Macquario-street, 60; Order of the Day postponed, 103, 192 (?), 252, 508; discharged, 586.			
Report of Board on Competitive Designs for, laid on Table, 196			
8		1279	
Motion made ( <i>Mr. Copeland</i> ) that this House do now adjourn to draw attention to proposed expenditure on, and withdrawn, 246.			
<b>STATE QUARRIES:—</b>			
Notifications of Amendment and cancellation of Regulations under the Crown Lands Act of 1884, laid on Table, 369			
5		595	
<b>STATISTICS:—</b>			
Statistical Register for 1887.			
Part III. Trade and Commerce, laid on Table, 352			
Do Part I. Population Immigration and Vital, laid on Table, 442			
Do Part IV. "Works and Manufactories", laid on Table, 479			
Do Part II. Crime and Civil Justice, laid on Table, 547			
Do Part VI. Production, laid on Table, 547			
Do Part VII. Education, Religion, and Charities, laid on Table, 547			
Do Part V. Monetary and Financial, laid on Table, 608			
Do Part VIII. Miscellaneous, Laid on Table, 626			
7		979	



REFERENCES TO THE VOTES AND PROCEEDINGS, VOL. I—13TH PARLIAMENT—SESSION, 1887—8.	PAPERS.
S	VOL. PAGE.
STATISTICS ( <i>continued</i> ):—	
CENSUS:—	
Return showing estimated population on 31 December, 1887, of New South Wales and Victoria respectively, 352 .....	7 1393
LIVE STOCK:—	
Return of, in the Australasian Colonies, 1871, 1881, 1887, laid on Table, 565 .....	8 597
PROGRESS OF THE COLONY OF NEW SOUTH WALES:—	
Statistical View of—since separation of Queensland, laid on Table, 462. ....	7 1395
SHIPPING AND IMPORTS AND EXPORTS:—	
Australasian, during the year 1887 and previous years, laid on Table, 519 .....	7 1397
STAYTON, MR. G. H., M. INST. C.E.:—	
SEWERAGE AND DRAINAGE OF THE WESTERN SUBURBS:—	
Report laid on Table, 267; Plan laid on Table ( <i>to be appended to the Report</i> ), 613; Sections of Sewers in connection with Report of, laid on Table ( <i>to be appended to the Report</i> ), 635 .....	5 895
STEAM TUGS (See "TUGS").	
STEVENS, CHARLES:—	
CLAIM OF:—	
Report of Select Committee adopted, 268.	
STEVENSON JAMES C. (See "CROWN LANDS").	
STIPENDIARY MAGISTRATE (See "ADMINISTRATION OF JUSTICE"; also "CIVIL SERVICE").	
STOCK (See also "LIENS ON WOOL BILL"; also "WATER SUPPLY"; also "PASTURES AND STOCK PROTECTION ACT AMENDMENT BILL"; also "DISEASES IN SHEEP AND IMPORTED STOCK ACTS;" also "PASTURES AND STOCK PROTECTION BOARDS"):—	
BRANCH, DEPARTMENT OF MINES:—	
Annual Report for 1886, laid on Table, 6; do. for 1887, laid on Table, 408.....	8 543, 573
DRILLS AND BORING OPERATIONS:—	
Report of the Superintendent of Drills on the 10½-mile, Bourke to Wanaaring Road, laid on Table, 302 .....	8 -953
STRANGERS, EXCLUSION OF:—	
Sessional Order passed, 12.	
STREET NORTH OF THE GENERAL POST OFFICE (See "FORMATION OF STREET, GENERAL POST OFFICE").	
STREETS (See "MUNICIPAL ROADS AND STREETS BILL").	
SUMMONS TO THE CLERK:—	
Reported, and leave given to produce Records, 89, 351.	
SUNDAY TIMES:—	
Motion made ( <i>Mr. Dibbs</i> ) that this House do now adjourn to discuss the action of the police in prosecuting persons for selling, and negatived, 186.	
SUNDAY TRAFFIC (See "RAILWAYS").	
SUPERANNUATION (See "CIVIL SERVICE").	
SUPPLY (See also "FINANCE"):—	
Committee of, Sessional Order passed, 11.	
Motion made ( <i>Mr. Burns</i> ) for the House to go into Committee, 174, 295, 345, 409, 433, 452, 476, 480, 544, 548, 553, 554, 610, 613, 619.	
House in Committee, 201, 242, 295, 345, 409, 433, 452, 476, 480, 544, 548, 553, 554, 610, 613, 619.	
Resolutions reported, 201, 242, 295, 345, 409, 480, 553, 619.	
Resolutions agreed to, 201, 242, 295, 345, 409, 480, 553, 625.	
Point of Order reported from Committee, 452.	
SUPREME COURT (See also "NEW TRIALS LIMITATION BILL"):—	
Rules of, laid on Table, 257, 635 .....	2 709, 711, 727
SUPREME COURT APPEALS ACT AMENDMENT BILL:—	
Motion made ( <i>Mr. Wise</i> ) for Committee of the Whole, 119; House in Committee, Resolution agreed to, presented and read 1°, 123; Message from Governor, 135; read 2°, committed, reported with an amendment, and report adopted, 140; read 3° and passed, 144; sent to Council, 145; returned without amendment, 157; Assent reported, 168.	2 -733
SURGERY (See "MEDICINE AND SURGERY").	
SURVEY OFFICE:—	
REMOVAL OF, FROM ALBURY TO WAGGA WAGGA:—	
Motion made ( <i>Mr. Day</i> ) for all reports, telegrams, and recommendations respecting, 41; Return to Order laid on Table, 476 .....	5 101
SURVEYORS (See "LICENSED SURVEYORS").	
SUSPENSION OF STANDING ORDERS (See "STANDING ORDERS").	
SWAMP-STREET, DOUBLE BAY:—	
Motion made ( <i>Mr. Neild</i> ) for papers in reference to alienation of land known as, 429; Return to Order laid on Table, 484 .....	8 1287
SWIFT, MR.:—	
CUSTOMS HOUSE OFFICER, BREWARRINA:—	
Motion made ( <i>Mr. Waddell</i> ) for papers, &c., in connection with dismissal of, 369; Return to Order laid on Table, 370 .....	2 133
SWORN (See "MEMBERS").	
SYDNEY (See also "RAILWAYS"; also "CITY OF SYDNEY MAYORAL ELECTION BILL"; also "WATER SUPPLY"):—	
DR. BOTTRELL'S CLAIM TO FORESHORES OF THE HARBOUR:—	
Motion made ( <i>Mr. Lyne</i> ) for all papers connected with, 40; Return to Order laid on Table, 185.	3 885
CITY OF SYDNEY IMPROVEMENT BOARD:—	
Annual Report for the year ended August, 1887, laid on Table, 112 .....	2 269
SYDNEY AND SUBURBAN ELECTRIC LIGHTING BILL:—	
Petition presented ( <i>Mr. H. H. Brown</i> ) for leave to bring in, 231; leave given, presented, and read 1°, 236; referred to Select Committee, 258; report brought up, 454.....	2 1099
SYDNEY AND SUBURBAN HYDRAULIC POWER COMPANY'S BILL:—	
Petition presented ( <i>Mr. Frank Smith</i> ) for leave to bring in, 415; leave given, presented and read 1°, 421; referred to Select Committee, 425; report brought up, 496.....	2 1185
Petition presented ( <i>Mr. Kethel</i> ), Municipal Council of Sydney, stating objections, and praying the House not to pass this Bill until the Petitioners considered the same, 421 .....	2 1131
SYDNEY CORPORATION ACT AMENDMENT BILL:—	
Motion made ( <i>Mr. O'Connor</i> ) for leave to bring in, presented and read 1°, 12; read 2°, committed, reported without amendment, and report adopted, 42; read 3°, passed, and sent to Council, 48; returned with amendments, 229; Order of the Day postponed, 232; amendments agreed to, 242; Message to Council, 243; Assent reported, 250.	

REFERENCES TO THE VOTES AND PROCEEDINGS, VOL. 1—13TH PARLIAMENT—SESSION, 1887-8.	PAPERS.	
	VOL.	PAGE.
<b>S</b>		
SYDNEY FREE PUBLIC LIBRARY :— Report from Trustees for 1887-8, laid on Table, 378.....	4	589
SYDNEY GRAMMAR SCHOOL :— Report for 1886, laid on Table, 285 .....	4	573
Do 1887, laid on Table, 432 .....	4	581
SYDNEY HARBOUR (See "PARLIAMENTARY STANDING COMMITTEE ON PUBLIC WORKS").		
SYDNEY HYDRAULIC-POWER COMPANY'S BILL :— Petition presented ( <i>Mr. Garrard</i> ) for leave to bring in, 257; presented and read 1 <sup>o</sup> , 263; referred to Select Committee, 268; report brought up, 349; read 2 <sup>o</sup> , committed, progress reported, and Question proposed,—That leave be given to sit again,—and the motion not having been put at 7 o'clock, Government Business took precedence, 421; Order of the Day postponed, 433, 476; leave given to Committee to sit again, 487; Order of the Day postponed, 579, 593, 602.	2	1129
Petition presented ( <i>Mr. McMillan</i> ), certain residents of Sydney in favour of the Bill, 420 .....	2	1183
Petition presented ( <i>Mr. Kethel</i> ), Municipal Council of Sydney, stating objections, and praying the House not to pass this Bill until the Petitioners considered the same, 421 .....	2	1181
SYDNEY MORNING HERALD :— Motion made ( <i>Mr. Melville</i> ) for adjournment of the House to consider attack on Member for Northumberland, 335.		
SYDNEY SEWERAGE (See "SEWERAGE").		
SYPHON (See "SYDNEY SEWERAGE").		
<b>T</b>		
TAMWORTH :— FIRE BRIGADES BOARD :— Regulations of, laid on Table, 6, 578 .....	2	611, 613
TANKS AND WELLS :— CONSTRUCTION AND MAINTENANCE OF :— Motion made ( <i>Mr. Waddell</i> ) that so much of Return ( <i>in part</i> ) to Order ( <i>Session 1883-4</i> ) laid on Table on 19 November, 1884, as relates to tanks at Galathera and Boggy Creek, be printed, 174	8	945
Motion made ( <i>Mr. Waddell</i> ) that all papers, minutes, and reports respecting complaints by Mines Department against Mr. Bennett, Commissioner and Engineer for Roads as to, and all correspondence respecting loss and inconvenience through works of, being divided between the Works and Mines Departments, 174; Return to Order laid on Table, 252 .....	8	671
Daysdale :—Notification of resumption of land for, laid on Table, 415 .....	8	951
TARIFF :— DUTY ON IMPORTED TIMBER :— Petition from Saw-mill Proprietors and others, that the carrying of, will cripple the trade, and praying that the reduction of the duty be not sanctioned, presented, 240.....	3	879
PROPOSED NEW :— Petition from Residents of Broughton Creek, Broger's Creek, Broughton Vale, and Kangaroo Valley against the abolition of the Customs Duties on Farm Produce, presented, and read by the Clerk, 252 .....	3	881
TATTERSALL'S CLUB BILL :— Received from Legislative Council, and on motion ( <i>Mr. Thompson</i> ) read 1 <sup>o</sup> , 346; read 2 <sup>o</sup> , committed, reported without amendment, report adopted, 421; read 3 <sup>o</sup> , passed and returned to Council, 425; assent reported, 435.		
TEACHERS (See "EDUCATION").		
TEARLE v. EDOLS (See "CROWN LANDS").		
TECHNICAL EDUCATION (See "EDUCATION").		
TELEGRAPHS :— COMMUNICATION WITH ROSEHILL RACECOURSE :— Motion made ( <i>Mr. Frank Farnell</i> ), for papers in reference to, 320.		
LINE TO MILPARINKA OR MOUNT BROWNE :— Motion made ( <i>Mr. Abbott</i> ) for all correspondence, petitions, and reports in reference to the construction of a line from Wanaaring to Milparinka or to Mount Browne, or from Wilcannia to those places, 24; Return to Order laid on Table, 228 .....	4	1143
ELECTRIC TELEGRAPH ACT :— Regulations under, respecting the reduction in Press Rates to New Zealand, and Messages in Cypher, laid on Table, 35 .....	4	1161
Regulation under, regarding Messages in Cypher, laid on Table, 608.....	4	1165
Notification under, of the reduction in rates for the transmission of telegrams from Silverton and Broken Hill to South Australia, laid on Table, 75.....	4	1163
IRON POLES :— Return respecting, laid on Table, 199.....	4	1183
ARTICLES SUPPLIED TO DEPARTMENT BY KINGSBURY & Co. :— Return to Order ( <i>Second Session, 1887</i> ) laid on Table, 128 .....	4	1167
Return respecting, laid on Table, 252 .....	4	1173
"GULCHER" ELECTRIC MACHINE :— Motion made ( <i>Mr. Thompson</i> ) for all letters, minutes, &c., relating to, for lighting, purchased by Department, 147; Returns to Order laid on Table, 231, 273 .....	4	1191, 1197
Motion made ( <i>Mr. Wall</i> ), that this House do now adjourn to direct attention to papers laid on Table, and negatived, 246.		
RATES BETWEEN NEW SOUTH WALES AND QUEENSLAND :— Papers respecting the proposed reduction of, laid on Table, 165 .....	4	1157
MR. LEESON :— Motion made ( <i>Mr. Hassall</i> ) for all papers, &c., referring to case of, 165.		
HORSES SUPPLIED TO DEPARTMENT :— Return showing cost, &c., of, laid on Table, 385 .....	4	1181
SITE OF OFFICE, ANGLEDOOL :— Motion made ( <i>Mr. Waddell</i> ) for papers in connection with, 493.		
EXTENSION OF LINES :— Motion made ( <i>Mr. Waddell</i> ) in reference to lines paying at commencement or not, 609.		
TELEPHONES :— Information respecting Multiple Cable, laid on Table, 267; further Return laid on Table, 335.....	4	1185, 1187
TELLERS (See "NO TELLERS").		

REFERENCES TO THE VOTES AND PROCEEDINGS, VOL. I—13TH PARLIAMENT—SESSION, 1887-8.	PAPERS.	
T	VOL.	PAGE.
<b>TENDERS:—</b>		
<b>CALLED FOR BY THE DEPARTMENT OF PUBLIC WORKS:—</b>		
Return to Order ( <i>Second Session</i> , 1887), laid on Table, 6.....	6	707
<b>HARBOURS AND RIVERS DEPARTMENT:—</b>		
Castings for the Hunter River District, 308 .....	3	913
<b>TERALBA COAL-MINING RESERVE:—</b>		
Adjournment of the House moved ( <i>Mr. McElhone</i> ) in reference to the Mineral Selections made by the Lane Family and Mr. Withers on, 493.		
Motion made ( <i>Mr. McElhone</i> ) for papers in connection with the Selections of the Lane Family, T. Garrett, Greville, and others, 500; Returns to Order laid on Table, 547, 580; referred to Select Committee, 587; Order for Printing rescinded, 592.		
Motion made ( <i>Mr. McElhone</i> ) for Select Committee on Selections of Lane Family, Henry T. Withers, and William Thorne, 502; Name of Sir Henry Parkes substituted for name of Mr. J. P. Abbott on, 585; Papers referred to Committee, 587.		
Plan of Reserves Nos. 83 and 60, showing Mineral Conditional Purchases and Mineral Leases held thereon, laid on Table, 547.		
<b>THEATRES (See also "PLACES OF PUBLIC AMUSEMENT OR RESORT"):—</b>		
Report on, and other public places of amusement, laid on Table, 128 .....	8	1209
<b>THEFTS (See "WORKMEN'S TOOLS").</b>		
<b>THOMPSON, R. W., ESQUIRE, M.P.:—</b>		
Name added to Select Committee on Crown Lands Purchases Validation Bill, 280.		
Name discharged from Select Committee, Resumption of Edward Irby's land at Bluff River, 432.		
<b>THOMPSON, THOMAS, CONDITIONAL PURCHASE OF (See "CROWN LANDS").</b>		
<b>THORNE, WILLIAM (See "TERALBA COAL-MINING RESERVE").</b>		
<b>THROUGH-TICKETS, SYDNEY TO BRISBANE (See "RAILWAYS").</b>		
<b>TIERNEY, JOHN—CONDITIONAL PURCHASE OF (See "CROWN LANDS").</b>		
<b>TIMBER DUTY (See "TARIFF").</b>		
<b>TIMBER LICENSES:—</b>		
Motion made ( <i>Mr. Waddell</i> ) for abolition of, for timber used for Smelting Purposes, 608.		
<b>TIMBER (See "STATE FORESTS AND FOREST RESERVES; also "CROWN LANDS").</b>		
<b>TIN-MINE AT PHEASANT'S CREEK (See "MINING").</b>		
<b>TOLLS AND FERRY DUES ON GOVERNMENT FERRIES:—</b>		
Motion made ( <i>Mr. Bowes</i> ) for abolition of, 608.		
<b>TOM, WILLIAM, JUN. (See "MINING").</b>		
<b>TOOHEY, MR.:—</b>		
<b>A MEMBER FOR SOUTH SYDNEY:—</b>		
Named by Mr. Speaker, motion made adjudging him guilty of contempt and committing him to custody of Sergeant-at-Arms, 156; apology made to House for causing disorder, and motion withdrawn, 157.		
<b>TOTALIZATOR LEGALIZING BILL:—</b>		
Motion made ( <i>Mr. Frank Farnell</i> ) for leave to bring in, 273; presented, and read 1 <sup>o</sup> , 324; Order of the Day postponed, 341, 361, 476, 493, 579, 593.		
Petition from Members of Clarence River Jockey Club, in favour of, presented, 285.....	8	1303
<b>TRADE AND COMMERCE (See "STATISTICS").</b>		
<b>TRADE IN WHEAT BETWEEN SYDNEY AND BARCELONA:—</b>		
Despatch respecting, laid on Table, 335, 475 .....	8	1309, 1311
<b>TRADE MARKS:—</b>		
Petition presented ( <i>Mr. Carruthers</i> ) from Manufacturers and Merchants of Sydney stating that they are suffering from the loss of empty packages, vessels, &c., bearing their trade marks, and praying for an amendment of the present Act, 416 .....	8	1301
<b>TRADE MARKS AMENDMENT BILL:—</b>		
Motion made ( <i>Mr. Carruthers</i> ) for leave to bring in, presented and read 1 <sup>o</sup> , 421; Order of the Day postponed, 508.		
<b>TRADES CONCILIATION BILL:—</b>		
Motion made ( <i>Mr. Carruthers</i> ) for Committee of the Whole, 52; Order of the Day postponed, 65, 107, 131, 288; House in Committee, Resolution agreed to, 321; presented, and read, 1 <sup>o</sup> , 342; referred to Select Committee, 386.		
<b>TRAFFIC (See "RAILWAYS").</b>		
<b>TRAMWAYS (See also "GOVERNMENT RAILWAYS BILL"; also "HAY AND DENILQUIN TRAMWAY BILL"; also "NORTH SHORE, MANLY, AND PITWATER TRAMWAY AND RAILWAY BILL"; also "BROKEN HILL TRAMWAY BILL"; also "SILVERTON TRAMWAY ACT AMENDING BILL"; also "KIAMA TRAMWAY ACT AMENDMENT BILL"; also "GOULBURN AND TUENA TRAMWAY BILL"):—</b>		
<b>RAILWAYS AND, OF NEW SOUTH WALES:—</b>		
Report on, for 1886, laid on Table, 6 .....	6	1
Do. for 1887, laid on Table, 635 .....	6	225
<b>GOVERNMENT:—</b>		
Motion made ( <i>Mr. Frank Farnell</i> ) for a return of expenditure on construction, giving cost of each line, with amount expended on rolling stock and machinery, 22; Return to Order laid on Table, 174 .....	6	1199
Motion made ( <i>Mr. McElhone</i> ) for return of correspondence in reference to leasing, 307; Return to Order laid on Table, 369 .....	6	1141
Return respecting, laid on Table, 524 .....	6	1201
<b>BLUE METAL FOR RAILWAYS AND:—</b>		
Motion made ( <i>Mr. O'Sullivan</i> ) for all tenders, minutes, and papers, relating to the purchase of 3,000 tons, 48; Return to Order laid on Table, 122 .....	6	1109
<b>LAND RESUMED FOR RAILWAY AND, PURPOSES:—</b>		
Motion made ( <i>Mr. Schey</i> ) for return showing the amount of compensation paid annually for, during the past seven years, giving particulars, 103; Return to Order laid on Table, 267 .....	6	1115
<b>AUTOMATIC ELECTRIC CARS:—</b>		
Correspondence respecting, laid on Table, 373 .....	6	1125
<b>EMPLOYEES:—</b>		
Motion made ( <i>Mr. Stephen</i> ) for return of particulars of dismissal, and re-employment of, 398.		
<b>IRON AND STEEL RAILWAY AND TRAMWAY MATERIALS:—</b>		
Motion made ( <i>Mr. Fletcher</i> ) for particulars of purchase of, 479.		
<b>MR. L. C. JENKINS, LATE DRIVER:—</b>		
Correspondence respecting, laid on Table ( <i>not printed</i> ), 505.		
<b>TRANSIT CHARGES ON MAILS THROUGH FRANCE AND ITALY:—</b>		
Correspondence respecting, laid on Table, 341 .....	4	1111
<b>TRANSIT COMMISSIONERS (See "METROPOLITAN TRANSIT COMMISSIONERS").</b>		

REFERENCES TO THE VOTES AND PROCEEDINGS, VOL. I—13TH PARLIAMENT—SESSION, 1887-8.	PAPERS.	
	VOL.	PAGE.
<b>T</b>		
TRAVELLING EXPENSES (See "DOCKER, JUDGE").		
TRICKETT WILLIAM JOSEPH, ESQ. :— Resignation of, as a Member for Paddington, reported, 249.		
TRUCKS (See "RAILWAYS").		
TRUST ACCOUNTS (See "ROAD TRUST ACCOUNTS.")		
TRUST FUNDS (See "FINANCE.")		
TRUSTEES (See also "PERPETUAL TRUSTEE COMPANY BILL"; also "PERMANENT TRUSTEE COMPANY OF NEW SOUTH WALES BILL"; also "ASSOCIATION CRICKET GROUND.")		
DEVONSHIRE-STREET CEMETERY :— Return showing names of, laid on Table, 263.....	8	1055
TRUSTEES OF PRESBYTERIAN CEMETERY, MACLEAN (See "PRESBYTERIAN CEMETERY AT MACLEAN").		
"TSINAN," S.S. :— Return respecting Chinese passengers by, laid on Table, 454 .....	2	211
TUENA (See "GOULBURN AND TUENA TRAMWAY BILL.")		
TUGS :— RICHMOND RIVER :— Conditions respecting the employment of, laid on Table, 165 .....	3	1065
STEAM SERVICE :— Motion made ( <i>Mr. See</i> ) for all letters, tenders, and other documents relating to the calling for and acceptance of tenders for, on various harbours and rivers for 1888, 220; Return to Order laid on Table, 280 .....	3	1053
TULCUMBA (See "ROADS").		
TULLY, MARTIN, JUNIOR (See "CROWN LANDS PURCHASES VALIDATION BILL").		
TUMBERUMBA (See "RAILWAYS").		
TYPHOID FEVER :— Report of Board of Health on, in Sydney and Suburbs from 1876 to 1888 laid on Table, 543 .....	2	231
Report of Board of Health on Treatment of, at the Coast Hospital, laid on Table, 608 .....	2	235
OUTBREAK OF, AT GLENDUART, MORUYA :— Motion made ( <i>Mr. Lokeman</i> ) for all papers relating to, 519; Return to Order, laid on Table, 578	2	239
<b>U</b>		
UNEMPLOYED (See also "CASUAL LABOUR BUREAU") :— Particulars respecting, laid on Table, 174 .....	8	1307
UNIVERSITY OF SYDNEY :— Amended By-laws, laid on Table, 6, 257 (2) .....	4	557, 569, 571
Information respecting Examination Fees during 1886-7 laid on Table, 348 .....	4	555
Report of, for 1887 laid on Table, 524 .....	4	547
UPPER MURRAY (See "RAILWAYS").		
USHER (See "BLACK ROD").		
<b>V</b>		
VACANT SEAT (See "ELECTORAL").		
VACCINATION :— Report for 1887, laid on Table, 479.....	2	229
VALIDATION BILL (See "CROWN LANDS PURCHASES VALIDATION BILL").		
VAUGHN MR. :— MEMBER FOR GRENFELL :— Declared guilty of persistent disorder and removed by the Sergeant-at-Arms from the Chamber, 221.		
"VERNON." (See "NAUTICAL SCHOOL SHIP "VERNON").		
VICTORIAN COAL-MINING COMPANY'S EXTENSION BILL :— Petition presented ( <i>Mr. Barbour</i> ) for leave to bring in, 181; leave given, presented, and read 1 <sup>o</sup> , 185; referred to Select Committee, 191; Report brought up, 201; read 2 <sup>o</sup> , committed, reported without amendment, and report adopted, 234; read 3 <sup>o</sup> and passed, 236; sent to Council, 237; returned with amendments, amendments agreed to, Message to Council, 410; Assent reported, 419.	2	1201
VINE DISEASES ACT AMENDMENT BILL :— Motion made ( <i>Sir Henry Parkes</i> ) for leave to bring in, presented, and read 1 <sup>o</sup> , 408; read 2 <sup>o</sup> , committed, reported with amendment, report adopted, 416; read 3 <sup>o</sup> , passed, and sent to Council, 422; returned with amendments, 422; amendments agreed to, Message to Council, 494: Assent reported, 540.		
VITAL STATISTICS (See "STATISTICS").		
VOLUNTEER FORCE REGULATION ACT :— Rules under, of 5th Regiment Scottish Rifles, laid on Table, 6 .....	2	37
Revised Regulations under, laid on Table, 257 .....	2	39
VOLUNTEERS (See also "MILITARY") :— VOLUNTEERS :— FREE RAILWAY PASSES ISSUED BY MILITARY STAFF OFFICE :— Return respecting, during quarter ended 30th June, 1888, laid on Table, 524.....	6	723
LAND ORDERS :— Motion made ( <i>Mr Crouch</i> ) for a Return showing number issued and made use of, specifying the number used in each Land District, 12; Return to Order laid on Table, 168 .....	2	31

REFERENCES TO THE VOTES AND PROCEEDINGS, VOL. I—13TH PARLIAMENT—SESSION, 1887-8.	PAPERS.	
	VOL.	PAGE.
<b>V</b>		
<b>VOTE OF CENSURE :—</b>		
<b>FINANCIAL POLICY OF THE GOVERNMENT :—</b>		
Motion made ( <i>Mr. Dibbs</i> ) that the Financial Policy of the Government is unsatisfactory, and amendment moved confining the question to such of the financial proposals of the Government as refer to the reduction of the Civil Service salaries, and debate adjourned, 208; debate resumed and further adjourned, 210, 216; debate resumed, <i>disorder</i> arose, and fourteen Members removed from the Chamber, 220, 221; amendment and original motion negatived. 222.		
<b>PURCHASE OF LAND ADJOINING THE AUSTRALASIAN STEAM NAVIGATION COMPANY'S WHARF :—</b>		
Motion made ( <i>Mr. Dibbs</i> ) that the evidence of the Select Committee discloses injudicious and unsatisfactory administration by the Government, and that the amount paid was in excess of its value, 329.		
<b>THE CHINESE :—</b>		
Motion made ( <i>Mr. Dibbs</i> ) condemning the Government for late acts in connection with, and amendment moved, 468.		
<b>VOTE OF CHAIRMAN OF SELECT COMMITTEE ON PRIVATE BILLS :—</b>		
Sessional Order passed, 11.		
<b>VOTE OF CREDIT :—</b>		
Message from Governor, recommending, 241 <sup>(2)</sup> , 285, 345, 404, 477, 553.		
<b>VOTES AND PROCEEDINGS (See "ASSEMBLY.")</b>		
<b>W</b>		
<b>WAGES OF EMPLOYEES :—</b>		
<b>DEDUCTIONS FROM, FOR MEDICAL COMFORTS :—</b>		
Motion made ( <i>Mr. Walker</i> ) for Select Committee to inquire into practice of Contractors, 353; Return to Order, "Patients received into Hospitals from Public Works," referred to; Committee, 462.		
<b>WAGGA WAGGA (See also "CROWN LANDS"; also "RAILWAYS") :—</b>		
<b>LAND OFFICES, ALBURY AND :—</b>		
Motion made ( <i>Mr. Day</i> ) for all papers, reports, &c., by Board of Inquiry into, 23.		
<b>REMOVAL OF SURVEY OFFICES FROM ALBURY TO :—</b>		
Motion made ( <i>Mr. Day</i> ) for all reports, minutes, and recommendations with reference to, 41. Return to Order, laid on Table, 476. ....	5	101
<b>WALGETT (See "RAILWAYS").</b>		
<b>WALKER, MR. :—</b>		
<b>A MEMBER FOR NORTHUMBERLAND :—</b>		
"Named" by Mr. Speaker, in Division; motion made adjudging him guilty of contempt, disorder arising, bars opened, and motion lapsed, 156.		
Declared guilty of persistent disorder, and removed by the Sergeant-at-Arms from the Chamber. 220.		
<b>WALL, MR. :—</b>		
<b>A MEMBER FOR MUDGEES :—</b>		
Declared guilty of persistent disorder, and removed by Sergeant-at-Arms from the Chamber, 221.		
<b>WALLSEND COAL COMPANY (See also "YOUNG WALLSEND COAL COMPANY'S RAILWAY BILL") :—</b>		
Correspondence respecting the case of the Crown v. Wallsend Coal Company, laid on Table, 524...	8	265
<b>WANARING ROAD (See "STOCK").</b>		
<b>WARATAH (See "RAILWAYS").</b>		
<b>WARRANT :—</b>		
Speaker's, issued committing Member to custody of Sergeant-at-Arms, 480.		
<b>WARREN, PROFESSOR (See "BRIDGES").</b>		
<b>WARREN SOUTH RUN (See "CROWN LANDS").</b>		
<b>WATER AND SEWERAGE (See "COUNTRY TOWNS WATER AND SEWERAGE ACT EXTENSION BILL"; also "COUNTRY TOWNS WATER AND SEWERAGE ACT").</b>		
<b>WATER AUGERS :—</b>		
Return of outstanding accounts in connection with, and Diamond Drills, laid on Table, 273.....	8	433
<b>WATER CONSERVATION :—</b>		
<b>LAKE CUDJELLICO AND THE LACHLAN RIVER :—</b>		
Motion made ( <i>Mr. Gormly</i> ) for construction of works, 560.		
<b>COMMISSION :—</b>		
Motion made ( <i>Dr. Ross</i> ) for all correspondence, vouchers, &c., relating to expenditure by the recently expired, 155. Return to Order, laid on Table, 565 .....	5	829
<b>WATER SUPPLY (See also "CROWN LANDS"; also "METROPOLITAN WATER AND SEWERAGE ACT AMENDMENT BILL") :—</b>		
Reports of Messrs. Bishop, Whitton, and Bennett, C.Es., on Prospect Dam, laid on Table, 529 ..	5	819
Report of Board appointed to inquire into Kenny Hill and Potts' Hill Reservoirs' Schemes, laid on Table, 547; Plan and tracing in reference to laid on Table ( <i>to be appended to the Report</i> ). 560 .....	5	853-869
Letter from F. B. Gipps, C.E., dated 5th July, 1888, to be appended to return, laid on Table ( <i>to be appended to Report</i> ), 578.		
<b>SYDNEY AND SUBURBS :—</b>		
Return respecting laid on Table, 635 .....	5	851
<b>LISMORE :—</b>		
Notification of resumption of certain land required in connection with construction of works for laid on Table, 5 .....	5	871
<b>BALRANALD :—</b>		
Notification, under the Country Towns Water and Sewerage Act, authorizing the construction of works for, laid on Table, 6.....	5	881
<b>PUBLIC WATERING PLACES :—</b>		
Return showing cost of maintenance and revenue of, laid on Table, 84 .....	8	949
<b>WESTERN SUBURBS OF SYDNEY AND DISTRICTS NORTH OF PARRAMATTA RIVER :—</b>		
Resumption of land under Lands under Public Purposes Acquisition Act required in connection with, laid on Table, 165.....	5	873

REFERENCES TO THE VOTES AND PROCEEDINGS, VOL. I—13TH PARLIAMENT—SESSION, 1887-8.	PAPERS.	
	VOL.	PAGE.
<b>W</b>		
<b>WATER SUPPLY</b> ( <i>continued</i> ) :—		
<b>TOWN OF ORANGE</b> :—		
Resumption of land under Public Purposes Acquisition Act required in connection with, laid on Table, 613.....	5	875
<b>WENTWORTH</b> :—		
Notification under Country Towns Water and Sewerage Act, completion of Water Supply Works for, 475.....	5	885
<b>WATSON'S BAY</b> (See "WHARVES").		
<b>WAYS AND MEANS</b> :—		
Committee of, Sessional Order passed, 11.		
Motion made ( <i>Mr. Burns</i> ) for the House to go into Committee, 174, 295, 346, 409, 430, 481, 501, 554, 561, 627.		
House in Committee, 201 ( <i>Financial Statement</i> ), 229, 234, 241, 242, 247, 295, 346, 409, 430, 481, 501, 554, 561, 627.		
Resolutions reported, 242, 248, 295, 346, 409, 430, 481, 554, 561, 627.		
Resolutions agreed to, 242, 248, 295, 346, 409, 430, 481, 554, 561, 627.		
Estimates of, for the year 1888, laid on Table, 201, 613.....	3	371, 461
<b>WEBB, FREDERICK WILLIAM</b> (See "CLERK OF ASSEMBLY").		
<b>WEEKLY ABSTRACTS OF PETITIONS</b> :—		
Nos. 1 to 37.....	1	745
<b>WEEKLY REPORTS OF DIVISIONS</b> :—		
Nos. 1 to 22.....	1	657
<b>WEIRS</b> ("See DAMS AND WEIRS REGULATION AND REGISTRATION BILL").		
<b>WELLINGTON</b> (See "RAILWAYS").		
<b>WELLS PUBLIC</b> (See "TANKS AND WELLS").		
<b>WENTWORTH</b> (See "ELECTORAL"; also "BRIDGES"; also "WATER SUPPLY.")		
<b>WENTWORTH ELECTORATE SUBDIVISION BILL</b> :—		
Motion made ( <i>Mr. Abbott</i> ) for leave to bring in, 40; presented and read 1 <sup>o</sup> , 49; read 2 <sup>o</sup> , committed, reported with amendments, 107; Order of the Day postponed, 113; report adopted, 131; read 3 <sup>o</sup> , passed, and sent to Council, 136; returned with amendments, 210; Order of the Day postponed, 237; Council's amendments agreed to, 243; Assent reported, 250.		
<b>WENTWORTH, WILLIAM CHARLES, PORTRAIT OF THE LATE</b> :—		
<b>CENTENNIAL EXHIBITION, MELBOURNE</b> :—		
Letters from Executive Commissioner asking for loan of pictures in the Parliamentary Buildings, and resolution passed against sending them, 569.		
<b>WERRIL ISAAC, GATEKEEPER, RAILWAY DEPARTMENT</b> :—		
Information respecting compensation to family of, laid on Table, 403.....	6	645
<b>WEST BOTANY</b> (See "ROCKDALE MUNICIPALITY NAMING BILL").		
<b>WEST MAITLAND CATTLE SALE-YARDS BILL</b> :—		
Petition presented ( <i>Mr. Brunker</i> ) for leave to bring in, 478; leave given, 493; presented and read 1 <sup>o</sup> , 501; referred to Select Committee, 507; report brought up, 519.....	2	1207
<b>WEST WALLSEND COLLIERY</b> (See "MINING").		
<b>WESTERN SUBURBS</b> (See "WATER SUPPLY"; also "SEWERAGE"; also "PARLIAMMENTARY STANDING COMMITTEE ON PUBLIC WORKS.")		
<b>WHALING ROAD, NORTH SHORE</b> :—		
Motion made ( <i>Mr. Levien</i> ) for a Select Committee on, 263; leave given for Committee to make visits of inspection, 287.		
Petition presented ( <i>Mr. Street</i> ) from North Shore Gas Company, praying for leave to appear before the Committee, and prayer granted, 294.....	5	1017
<b>WHARVES</b> (See also "PARLIAMMENTARY STANDING COMMITTEE ON PUBLIC WORKS") :—		
<b>DRUMMOYNE PARK</b> :—		
Motion made ( <i>Mr. Carruthers</i> ) for all leases, tenders, correspondence, &c., relating to leasing of, 122; Return to Order laid on Table, 199.....	3	1021
<b>NEAR FREDERICKTON, MACLEAY RIVER</b> :—		
Notification of resumption of land for, laid on Table, 475.....	3	1049
<b>NEAR GHINNY GHINNY</b> :—		
Notification of resumption of land for, laid on Table, 475.....	3	1051
<b>MOAMA</b> :—		
Report upon extension of channel and improvements, laid on Table, 302.....	3	1039
<b>ACCOMMODATION FOR TRAFFIC BETWEEN SYDNEY AND BALMAIN</b> :—		
Petition presented residents and others Western Suburbs in favour of additional, and read by Clerk, 543.....	3	1041
<b>PUBLIC, AT WATSON'S BAY</b> :—		
Motion made ( <i>Mr. Neild</i> ) for papers relating to leasing of, 585; Return to Order laid on Table, 642.....	3	1043
<b>WHEAT</b> :—		
Despatches respecting Trade between Australia and Barcelona, laid on Table, 335, 475.....	8	1309, 1311
<b>WHITTINGHAM PLATFORM</b> (See "RAILWAYS").		
<b>WHITTON, MR. C. E.</b> :—		
Report of, on Prospect Dam, laid on Table, 529.....	5	849
<b>WILCANNIA</b> (See "BRIDGES").		
<b>WILKINSON'S COMBINATION TRUCK</b> (See "RAILWAYS").		
<b>WILKINSON, W. C., ESQ., M.P.</b> (See "PRINCE ALFRED HOSPITAL").		
<b>WINES</b> (See also "SPIRITS") :—		
<b>PRODUCTION OF</b> :—		
Petition presented from Vinegrowers of New South Wales, in reference to, and suggesting measures for assisting the industry, and read by the Clerk, 635.....	8	1257
<b>WISE, THE HONORABLE BERNHARD RINGROSE, ESQUIRE, M.P.</b> :—		
Motion made ( <i>Mr. Dibbs</i> ) as privilege, to refer to Committee of Elections and Qualifications whether Mr. Wise, one of the Members for South Sydney, has not, since his election, accepted an office of emolument, having accepted a fee of fifty-five guineas from the Commissioner for Railways, in contravention of the 28th section of the Constitution Act, 53; Report brought up, 55.....	1	903
Resignation of Office of Attorney-General by, 252.		
<b>WITHERS, HENRY</b> (See "TERALBA COAL-MINING RESERVE").		
<b>WOOD PAVING</b> :—		
Return respecting cost of in the City and Suburbs, laid on Table, 420.....	2	289
<b>WOODWARD, FRANCIS, ESQ., M.P.</b> :—		
Leave of absence granted to, 308.		

REFERENCES TO THE VOTES AND PROCEEDINGS, VOL. I—13TH PARLIAMENT—SESSION, 1887-8.	PAPERS.	
	VOL.	PAGE.
<b>W</b>		
WOODSTOCK (See "RAILWAYS").		
WOOL (See also "LIENS ON WOOL BILL").		
WOOL, CARRIAGE ON :—		
Original tenders for from Railway Station, Redfern, and Darling Harbour, laid on Table ( <i>as Exhibits only</i> ), 454		
WOOLLOOMOOLOO BAY (See "PARLIAMENTARY STANDING COMMITTEE ON PUBLIC WORKS.")		
WORDS OF HEAT (See "M'ELHONE, JOHN, ESQ., M.P.")		
WORKMEN'S TOOLS :—		
Return respecting Thefts of, laid on Table, 302.....	8	1297
WORKS, NATIONAL AND LOCAL :—		
Statement of expenditure on, in the Colony, from 1860 to 1886, laid on Table, 28.....	8	1231
WORKS AND MANUFACTORIES (See "STATISTICS").		
WORKSHOPS (See "RAILWAYS," also "FACTORIES AND WORKSHOPS REGULATION BILL").		
WRITS OF ELECTION (See "ELECTORAL").		
<b>Y</b>		
YASS ROMAN CATHOLIC CHURCH LAND SALE BILL :—		
Petition presented ( <i>Mr. Colls</i> ) for leave to bring in, 58 ; leave given, presented, and read 1 <sup>o</sup> , 64 ; referred to Select Committee, 70 ; Report brought up, 99 ; read 2 <sup>o</sup> , committed, reported without amendment, and report adopted, 147 ; read 3 <sup>o</sup> , passed, and sent to Council, 150 ; returned without amendment, 210 ; Assent reported, 239.	2	1215
YATES MR. LEOPOLD, ACTING STIPENDIARY MAGISTRATE :—		
Information respecting, laid on Table ( <i>not printed</i> ), 378 .....	2	1215
YOUNG (See "RAILWAYS").		
YOUNG, THE HONORABLE JAMES HENRY, M.P. (See "SPEAKER").		
YOUNG WALLSEND COAL COMPANY'S RAILWAY BILL :—		
Petition presented ( <i>Mr Brunker</i> ) for leave to bring in, 613 ; leave given, presented, and read 1 <sup>o</sup> , 619.		

1887.

(THIRD SESSION.)

---

LEGISLATIVE ASSEMBLY.

NEW SOUTH WALES.

---

# LETTERS OF REGISTRATION OF INVENTIONS

UNDER

16 VICTORIA, No. 24;

FOR

1883.

---

Printed in accordance with Resolution of Legislative Assembly.

---



SYDNEY : CHARLES POTTER, GOVERNMENT PRINTER.

---

1887.

[12s.]

9-a

[860 copies—Approximate Cost of Printing (labour and material), £711 18s. 10d.]



1887.

---

LEGISLATIVE ASSEMBLY.

NEW SOUTH WALES.

---

## LETTERS OF REGISTRATION OF INVENTIONS.

(DESCRIPTIONS, SPECIFICATIONS, &c., ACCOMPANYING APPLICATIONS FOR.)

---

Printed in accordance with Resolution of Legislative Assembly.

---

RETURN (in part) to an *Address* of the Honorable the Legislative Assembly of New South Wales, dated 10 May, 1861, A.M., praying that His Excellency the Administrator of the Government would be pleased to cause to be laid upon the Table of this House (in addition to the Return already upon the Table),—

“(1.) A copy of the Descriptions and Specifications accompanying any applications for Letters of Registration of Inventions under the Act of Council 16 Victoria, No. 24, together with the date of application for such Letters of Registration, and when granted; also, copies of the Plans or Sections annexed, and of the Report, in each case.

“(2.) That His Excellency will cause similar Returns to be laid before Parliament annually.”

(*Mr. Hart.*)

---

## INDEX.

No.	NAME OF APPLICANT.	DATE OF APPLICATION.	NATURE OF INVENTION.	WHEN GRANTED.	PAGE.
<b>1883.</b>					
1176	Frank Wright, and Matthew and William Wallbank Mackie.	15 Nov., 1882	A new or improved apparatus for blowing and shaping glass.	2 January ..	1
1177	James Chalmers Brodie...	20 Nov., 1882	Improvements in spring-handle cricket-bats.....	2 January ...	3
1190	Arthur Albert Bushell ...	10 Nov., 1882	Improvement in the manufacture of spring mattresses, couches, and chairs in which springs may be used.	19 January ...	53
1178	Henry Bezer .....	3 Nov., 1882	Improved means of locking nuts .....	2 January ...	5
1189	Richard Barker .....	2 Dec., 1882	An improved method of, and means or apparatus for, extracting gold and silver from their ores by the combined action of electricity and mercury.	19 January ...	49
1188	Edwin Tatham, John Tatham, and Charles Shepherd.	20 Nov., 1882	Improvements in means for raising sunken vessels.	19 January ...	47
1187	Edwin Tatham .....	3 Oct., 1882	A fire-indicator and alarm.....	19 January ...	45
1186	James Edward Henry Gordon.	2 Dec., 1882	Improvements in dynamo-electric machines .....	19 January ...	39
1181	William Hooker .....	23 Nov., 1882	A perpendicular gas generating burner for portable lamps, constructed to contain a reservoir of illuminating fluid.	19 January ...	19
1182	Tasman Algar Phillips ...	21 Nov., 1882	Improvements in machines for excavating and removing ploughed or soft earth.	19 January ...	23
1185	John Campbell .....	27 Nov., 1882	Improvements in ore furnaces.....	19 January ...	35
1184	John Hopkinson.....	20 Nov., 1882	Improvements in dynamo-electric machines.....	19 January ...	31
1183	Louis John Crossley, John Frederic Harrison, and Walter Emmott.	2 Dec., 1882	Improvements in electric signalling apparatus, applicable also to other purposes.	19 January ...	27
1180	James Howard, Edward Tenney Bonsfield, and Henry William Gibbs.	18 Nov., 1882	Improvements in harrows .....	19 January ...	15
1179	William Crookes .....	2 Dec., 1882	Improvements in the construction and manufacture of electric lamps.	19 January ...	9
1191	George Richard Dibbs and Frederick Hugh Thomas.	14 Nov., 1882	An improvement in the manner of manufacturing Portland Cement, to be called "Australasian Portland Cement."	6 February...	55
1193	The Jerome Automatic Packing Co. (Limited).	6 Sept., 1882	Improvements in piston-rod packings.....	10 February..	57
1194	Milan Constant Bullock..	4 Dec., 1882	Improvements in rock-drilling machines .....	12 February..	61
1195	Milan Constant Bullock..	4 Dec., 1882	Improvements in rock-drilling machines .....	12 February...	65
1201	Edward Pritchard .....	20 Dec., 1882	A machine for mining tunnels, by cutting grooves round the sides of tunnels, drives, sewers, or drains, in rock or other material.	23 February...	81
1199	Paul Jablochhoff .....	18 Dec., 1882	A new or improved dynamo-electric or electro-dynamic machine.	23 February...	75
1200	John Chambers .....	18 Dec., 1882	Improvements in refrigerating and freezing, and in apparatus employed for such purposes.	23 February...	77
1197	Edward William Cracknell.	22 Dec., 1882	An improvement in hydraulic lifting machines...	23 February...	71
1198	James Hamilton Fraser...	18 Dec., 1882	A machine for generating the electric current or for use as an electro motor.	23 February...	73
1202	Henry Caspers .....	11 Nov., 1882	A machine for manufacturing burning gas .....	1 March .....	83
1205	Fridolf Schauman .....	29 Dec., 1882	Improvements in the permanent-way of railways	5 March .....	91
1206	Thomas Alva Edison .....	29 Dec., 1882	Improvements in means for indicating and regulating the current of electrical generators for supplying electric lights and other purposes.	5 March .....	93

No.	NAME OF APPLICANT.	DATE OF APPLICATION.	NATURE OF INVENTION.	WHEN GRANTED.	PAGE.
				<b>1883.</b>	
1203	William Wilkinson .....	18 Dec., 1882	Improvements in tramway locomotives .....	5 March .....	85
1204	Robert Scott .. .....	6 Jan., 1883	An improvement in stamp batteries .....	5 March .....	89
1211	Hiram Stevens Maxim ...	13 Jan., 1883	Improvements in the manufacture of carbon conductors for electric lamps, and in apparatus to be employed in such manufacture.	17 March .....	107
1209	Edward Weston .....	13 Jan., 1883	Improvements in electric lighting apparatus, and in apparatus for use in connection therewith.	17 March .....	101
1212	Edward Weston .....	13 Jan., 1883	Improvements in dynamo-electric machines .....	17 March .....	111
1210	Edward William Cracknell.	15 Jan., 1883	An improved balance lift ... ..	17 March .....	105
1217	Alfred Kirby Huntington and Walter Edward Koch.	27 Jan., 1883	An improved process for extracting precious metals from their ores.	9 April .....	121
1216	Carl Wagemann .....	30 Jan., 1883	Improvements in machinery for extracting ores and metals from minerals and other metalliferous material after being ground or crushed.	9 April .....	117
1219	Samuel Crowder .....	5 Jan., 1883	Improvements in moulding pottery by pressure	13 April .....	127
1220	William Bartholomew ...	27 Jan., 1883	Improvements in water-waste preventers .....	13 April .....	129
1218	Jules Louis Moret .....	27 Jan., 1883	An improved treatment for softening, unhairing, puring, ungreasing, and preserving hides and skins.	13 April .....	123
1221	Henry Albert Davis .....	10 Feb., 1883	Improvements in umbrellas .....	16 April .....	133
1222	Edward William Cracknell.	15 Jan., 1883	An improved slide-valve .....	16 April .....	137
1227	Joseph Wilson Swan .....	29 June, 1881	Improvements in and connected with electric lamps.	19 April .....	147
1225	James Kay, William Aspinall, and Bernard Rafferty.	12 Jan., 1883	The open-top fuel distributing kiln .....	20 April .....	141
1229	Charles Francis Brush ...	18 Dec., 1882	Improvements in electric lamp apparatus .....	21 April .....	153
1226	Norman Selfe .....	22 Jan., 1883	Improvements in hydraulic pressing machinery	21 April .....	143
1230	Charles D'Abadie de Barrau.	6 Jan., 1883	The production of sulphurous acid gas to be employed in the manufacture of sugar.	21 April .....	157
1228	Eli Fraiser Russell .....	21 Feb., 1883	Improvements in the art or process of conglomerating particles for roasting and smelting, which is applicable particularly for forming black sand into bricks in the manufacture of iron and stone from black sand.	21 April .....	151
1232	John Edgecumbe Rendle..	13 Oct., 1882	Improvements in the construction of glazed roofs and other glazed structures.	25 April .....	161
1233	The Llewellyn Steam Condenser Manufacturing Company.	30 Nov., 1882	Improvements in feed-water filters, heaters, purifiers, and condensers for steam boilers.	12 May.....	165
1238	Henri Herrenschmidt and Marmaduke Constable.	20 Jan., 1883	An improved process of extracting the oxides of cobalt and manganese from their ores.	19 May.....	171
1239	King David Sykes .....	27 Feb., 1883	The portable hygienic bath .....	19 May.....	173
1237	John Shaw .....	21 Nov., 1882	An improved method of converting hides and skins into leather.	19 May.....	169
1240	Charles Farquhar Findlay	22 Feb., 1883	Improvements in rope traction railways or tramways.	19 May.....	175
1243	George Cowdery and Edwin Robins Thomas.	10 Mar., 1883	An improved rail for railways to be called "The Hydra-headed Rail."	25 May.....	183
1242	John Turner and James Robertshaw.	13 Mar., 1883	Improvements in sanitary receptacles and appliances.	26 May.. .....	179
1244	Herbert Maguire Whitehead.	16 Mar., 1883	An improved method of and appliances for stowing bags of wool, hair, jute, and the like inboard steam and other vessels, and the formation of walls of chambers or compartments thereby within which meat and other perishable food may be preserved.	26 May.....	187
1249	William Stuntz .....	13 Mar., 1883	Stuntz's stop-motion brick-moulding machine ...	26 May .....	205

No.	NAME OF APPLICANT.	DATE OF APPLICATION.	NATURE OF INVENTION.	WHEN GRANTED.	PAGE.
				<b>1883.</b>	
1248	Relp Cunniff Dixon .....	5 Mar., 1883	An improved apparatus for producing illuminating and heating air-gas.	26 May .....	201
1247	Ebenezer Farie Macgeorge	22 Mar., 1883	An improved clinometer compass, and an improved apparatus for reading its indications.	26 May .....	197
1245	Heinrich Ujhely .....	8 Mar., 1883	Improvements in the method or process for extracting, refining, and hardening paraffine wax.	26 May .....	191
1246	Franz Krizik and Ludwig Piette.	27 Jan., 1883	Improvements in electric lamps ... ..	30 May .....	193
1253	Lucian Gaulard and John Dixon Gibbs.	6 April, 1883	A new system of distributing electricity for the production of light and power.	4 June .....	217
1252	Bernhard Heinrich Remmers and John Williamson.	5 April, 1883	Improvements in and connected with the refining or purifying of sugar and saccharine matter.	4 June .....	213
1251	James McFarlane Robison, Thomas Buchanan Campbell Robison, and Henry Dodds.	22 Mar., 1883	An improvement in centrifugal pumps .....	4 June .....	211
1250	Alexander Leslie Fyfe and John Main.	18 Dec., 1882	Improvements in arc electric lamps and regulators.	4 June .....	207
1254	Friedrich Hoffman .....	11 July, 1882	An improvement in permanent-way .....	11 June .....	221
1256	George Westle .....	1 Mar., 1883	Improvements in machines for excavating and removing earth.	12 June .....	225
1255	Frederic Isenbart Scard...	20 April, 1883	Improvements in the process of fermenting liquids.	12 June .....	223
1259	Walter Bowness Benns...	30 April, 1883	An improved buffer for cab and other hinged doors.	12 June .....	235
1258	Samuel Lowe .....	12 April, 1883	An improved clothes washing-machine .....	12 June .....	233
1257	The Hydraulic Elevator Company.	11 April, 1883	Improvements in hydraulic elevators .....	12 June .....	229
1265	Charles Francis Brush ...	18 Dec., 1882	Improvements in secondary batteries or magazines of electricity.	27 June .....	257
1261	Lazare Weiller .....	7 May, 1883	Improvements in the manufacture of silicious copper and silicious bronze, particularly suited for making electric conducting-wires.	27 June .....	237
1262	Charles Francis Brush ...	4 May, 1883	Improvements in apparatus for automatically manipulating the current employed in charging secondary batteries or magazines of electricity.	27 June .....	241
1264	Sydney Gilchrist Thomas	6 April, 1883	Improvements in the manufacture of steel and iron, and the apparatus used therefor.	27 June .....	253
1263	Joshua Barker Carter ...	29 Mar., 1883	An improved contrivance for paring and coring fruit and vegetables.	27 June .....	251
1268	William John Cooper ...	3 May, 1883	Improvements in the distillation of coal for obtaining products therefrom.	29 June .....	271
1266	William Wilson Macvay and Richard Sykes.	29 Mar., 1883	Improvements in stoppering bottles .....	29 June .....	265
1267	James Robson ... ..	6 April, 1883	Improvements in obtaining and applying motive power.	29 June .. ..	267
1270	Carson Woods .....	30 April, 1883	Improvements in railway cars or waggons .....	29 June .....	275
1269	Walter William Cook and Hubert Ligar Cook.	1 May, 1883	Patent paragon fire-kindlers .....	29 June .....	273
1271	William Wilkinson .....	11 May, 1883	Improvements in wool-washing machines .....	3 July .....	283
1272	Norman Selfe .....	2 May, 1883	Hydraulic improvements in closing doors and shutters.	3 July .....	287
1273	Charles Edgar Sackett ...	3 May, 1883	Improvements in tilling machines .....	3 July .....	289
1275	Pehr Adolph Holmgren...	5 May, 1883	Improvements in safety-guards for tram and railway rolling stock.	14 July .....	295
1278	Walter Andrew Harper, John C. Dibbs, and Carson Woods.	7 June, 1883	Bituminous concrete .....	26 July .....	299

No.	NAME OF APPLICANT.	DATE OF APPLICATION.	NATURE OF INVENTION.	WHEN GRANTED.	PAGE.
<b>1883.</b>					
1281	Benjamin Barnes .....	1 June, 1883	Improved excavator or digger .....	6 August .....	305
1280	William John Tanner ...	31 May, 1883	Improvements in the treatment of gold and silver ores by the combined action of electricity and water, and in apparatus for the purpose.	6 August .....	301
1282	Pierre Manhes.....	14 June, 1883	Improvements in the treatment of copper ores and other cupreous materials for the obtainment of copper therefrom, and in refining impure copper, and in the apparatus to be employed in the said treatment.	6 August .....	307
1285	Edmund Taylor and William Humble.	31 May, 1883	Improvements in and relating to refrigerating machines, and to the manufacture of ice.	8 August .....	319
1292	Thomas Alva Edison .....	21 May, 1883	Improvements in or relating to apparatus for the generation, distribution, and utilization of electrical energy.	8 August .....	343
1286	Richard Barker .....	31 May, 1883	Improvements in extracting gold and silver from their ores, and in apparatus for the purpose.	8 August .....	323
1290	Charles Henry Walker Biggs and William Worby Beaumont.	14 June, 1883	Improvements in secondary batteries for the production, conservation, and regulation of electric currents.	8 August .....	335
1289	Alfred Kirby Huntington and Walter Edward Koch	31 May, 1883	A new or improved amalgamating apparatus ...	8 August ...	331
1284	Desmond Gerald FitzGerald, Charles Henry Walker Biggs, and William Worby Beaumont.	14 June, 1883	Improvements in secondary batteries .....	8 August ...	315
1287	George Fry, Carl Daniel Ekman, and William Bancroft Espent.	4 June, 1883	Improvements in the extraction of saccharine matter from vegetable substances.	8 August ...	325
1291	John Kissack Joshua Foster.	4 June, 1883	Improvements in extinguishing fires, and in apparatus to be employed therefor.	8 August ...	339
1283	Desmond Gerald FitzGerald and Thomas John Jones.	31 May, 1883	Improvements in secondary or storage batteries.	8 August ...	311
1288	Rookes Evelyn Bell Crompton and Desmond Gerald FitzGerald.	14 June, 1883	Improvements in galvanic batteries and electrochemical accumulators.	8 August ..	327
1294	Auguste Frayse .....	15 June, 1883	Improvements in picking, cleaning, and burring wool and similar material, and in apparatus to be used therefor.	14 August ...	355
1295	Joseph C. Wightman .....	16 June, 1883	Improvements in implements for shearing sheep, and in machinery for driving same.	14 August ...	359
1293	William John Tanner ...	31 June, 1883	Improvements in apparatus for washing and separating gold and silver from their ores.	14 August ...	351
1296	John Jameson .....	27 June, 1883	Improvements in and connected with the manufacture of coke.	16 August ...	363
1297	Edward John Honeychurch Broad and William Thomas Poole.	10 July, 1883	Improvements in the manufacture of white lead from metallic lead.	20 August ...	369
1299	Pardon Armington.....	26 June, 1883	Improvements in steam engines .....	25 August ...	371
1303	Silas Reynolds Divine ...	13 July, 1883	An improvement in an explosive compound, and its use in the art of blasting.	28 August ...	379
1302	Ernest Sydney Burman...	2 July, 1883	A pump for the extraction of night-soil and other matters in a fluid or semi-fluid state from cess-pits or other places to receptacles for the same, and, during the process of such removal, disinfecting and rendering all noxious gases therefrom inodorous.	28 August ...	377
1384	Edmund Cogswell Converse.	13 July, 1883	Improvements in coupling for tubing.....	28 August ...	383
1301	Alfred Holden.....	6 July, 1883	Improvements in the construction of toothed and pronged implements, such as rakes, harrows, combs, &c.	28 August ...	375
1305	The Veloplastic Company (Limited).	11 July, 1883	A new or improved manufacture of material in imitation of leather, woods, fabrics, or other embossed or figured surfaces.	28 August ...	387

No.	NAME OF APPLICANT.	DATE OF APPLICATION.	NATURE OF INVENTION.	WHEN GRANTED.	PAGE.
				<b>1883.</b>	
1312	William Hassalwood Carmont.	27 June, 1883	Improvements in the manufacture of grooved tyres for wheels, and in the fastening of india-rubber or other yielding material therein.	17 September	409
1310	Stephen Preston Tallman	13 June, 1883	Improvements on, and relating to, stock cars ...	17 September	403
1308	Stephen Preston Tallman	13 June, 1883	Improvements on, and relating to, automatic car-brakes.	17 September	395
1311	James Hutchings .....	27 June, 1883	An improvement in earth-scoops .....	17 September	407
1309	Arthur Cooper.....	11 July, 1883	Improvements in the treatment of iron or steel ingots.	17 September	399
1307	Frederick York Wolseley	20 July, 1883	An improved machine for excavating earth .....	17 September	391
1313	John William Hall Hullett.	26 April, 1883	An improvement in rolling-stock for break of gauge railways and tramways.	20 September	413
1319	Fountain Livet.....	10 Aug., 1883	Improvements in furnace-bars, flues, expansion chambers, and in tubes.	4 October ...	433
1318	Edwin Jenkins, Alexander Law, and William Price.	4 June, 1883	An improved process of annealing chilled and other iron castings.	4 October ...	431
1314	Thomas Lunham Baker...	18 June, 1883	Improved excavating machine and dredge.....	4 October ...	415
1320	Fleeming Jenkin.....	31 May, 1883	Improvements in mechanism used for transporting goods and passengers by the aid of electricity.	4 October ...	437
1316	Henry Gerner .....	10 Aug., 1883	Improvements in the treatment of india-rubber, gutta-percha, and analogous gums.	4 October ...	423
1315	Adam Cyrus Engert .....	3 May, 1883	Improvements in steam boilers and furnaces.....	4 October ...	419
1317	John Furphy .....	3 Aug., 1883	Improvements in the construction of grain-stripping machines.	4 October ...	427
1324	Thomas Tolley Jones.....	28 July, 1883	An improved machine to be used in the manufacture of cartridges from dynamite and other nitro-glycerine compounds for mining, blasting, and kindred purposes.	11 October ...	457
1321	Thomas Henry Fielding and Albert Nathan Jensen.	21 Aug., 1883	The application of polished metallic substances for the exclusion of radiant heat.	11 October ...	445
1322	Alfred Swan .....	22 Aug., 1883	Improvements in the manufacture or construction of incandescent electric lamps, and in machinery or apparatus employed therein, and in holders for the said lamps.	11 October ...	447
1323	Richard John Sankey.....	9 Aug., 1883	Improvements in stoppering bottles for containing aerated liquids.	11 October ...	453
1325	James Brookhouse Preston and James Shepherd	17 Aug., 1883	Improvements in machinery for turning or shaping solid material to an irregular or regular pattern.	11 October ...	459
1326	Lazare Weiller .....	22 Aug., 1883	Improvements in the manufacture of silicious copper and silicious bronze, and the preparation of certain compounds suitable to be employed in such manufacture.	12 October ...	463
1329	Peter Stuart .....	9 Feb., 1883	Improvements in the manufacture and laying of composite pavement, floors, platforms, landings, stair-steps, and the like, and in composition therefore.	24 October ...	467
1330	John William Post.....	30 Aug., 1883	Improvements in sewing-machines .....	25 October ...	471
1331	William Thomson, Sebastian Liani de Ferranti, and Alfred Thompson.	21 Aug., 1883	Improvements in dynamo-electric machines .....	26 October ...	477
1332	William Thomson, Sebastian Liani de Ferranti, and Alfred Thompson.	21 Aug., 1883	Improvements in apparatus for generating and regulating electric currents used in working dynamo machines, and for other purposes.	26 October ...	483
1333	William Thomson, Sebastian Liani de Ferranti, and Alfred Thompson.	21 Aug., 1883	Improvements in apparatus for measuring electric currents used in working dynamo machines, and for other purposes.	26 October ...	487
1338	William Adam Dixon and Robert Saddington.	30 Aug., 1883	A new or improved compound for lubricating machinery.	17 November	497
1337	Josiah Earl .....	27 Aug., 1883	Improvements in windmills .....	17 November	493

## INDEX.

No.	NAME OF APPLICANT.	DATE OF APPLICATION.	NATURE OF INVENTION.	WHEN GRANTED.	PAGE.
				<b>1883.</b>	
1339	Robert A. Chesney.....	21 Mar., 1883	Robert A. Chesney's Dunlop earth-scoop .....	17 November	499
1336	William Bowman .....	15 May, 1883	Improvements in grain stripping and winnowing machines.	17 November	489
1340	John Handley Knibbs, Frank Joseph Knibbs, and Alfred Edwin Knibbs	31 Aug., 1883	White or raw hide composite mill-bands or belting.	3 December	503
1342	Colin Mackay, Henry Walden, and Henry North.	8 Sept., 1883	Improvements in barbed wire .....	3 December	507
1341	James Ballantyne Hannay	6 Oct., 1883	Improvements in applying zinc for preventing corrosion in steam boilers.	3 December	505
1345	Charles Benjamin Taylor	13 Nov., 1883	Machine for rolling (with or without wire), closing, and fastening bottoms in all kinds of hollow-ware made from sheet metals, either tin, brass, copper, iron, or zinc.	21 December	509
1346	William Buller Fullerton Elphinstone and Charles Wilson Vincent.	24 Sept., 1883	Improvements in the construction of dynamo-electric machines.	27 December	511
1347	David Murray and Arthur Wellesley Parkinson.	10 Sept., 1883	An improved portable gas machine.....	27 December	517



A.D. 1883, 2nd January. No. 1176.

IMPROVED APPARATUS FOR BLOWING AND SHAPING GLASS.

LETTERS OF REGISTRATION to Frank Wright and Matthew William Wallbank Mackie, for an invention entitled "A new or improved Apparatus for blowing and shaping Glass."

[Registered on the 5th day of January, 1883, in pursuance of the Act 16 Vic., No. 24.]

BY HIS EXCELLENCY THE RIGHT HONORABLE SIR AUGUSTUS WILLIAM FREDERICK SPENCER LOFTUS (commonly called LORD AUGUSTUS LOFTUS), Knight Grand Cross of the Most Honorable Order of the Bath, a Member of Her Majesty's Most Honorable Privy Council, Governor and Commander-in-Chief of the Colony of New South Wales and its Dependencies.

TO ALL TO WHOM THESE PRESENTS SHALL COME, greeting :

WHEREAS FRANK WRIGHT and MATTHEW WILLIAM WALLBANK MACKIE, both of No. 80, Gray's Inn Road, in the county of Middlesex, England, electrical engineers, have by their Petition humbly represented to me that they are the authors or designers of a certain invention or improvement in manufactures, that is to say, of an invention entitled "A new or improved Apparatus for blowing and shaping Glass," which is more particularly described in the specification and the sheet of drawings, which are hereunto annexed; and that they, the said Petitioners, have deposited with the Honorable the Treasurer of the said Colony of New South Wales the sum of Twenty Pounds sterling, for defraying the expense of granting these Letters of Registration, as required by the Act of Council, sixteenth Victoria, number twenty-four; and have humbly prayed that I would be pleased to grant Letters of Registration, whereby the exclusive enjoyment and advantage of the said invention or improvement might be secured to them for a period of fourteen years: And I, being willing to give encouragement to all inventions and improvements in the arts or manufactures which may be for the public good, and having received a report favourable to the prayer of the said Petition, from competent persons appointed by me to examine and consider the matters stated therein and to report thereon for my information, am pleased, with the advice of the Executive Council, and in exercise of the power and authority given to me by the said Act of Council, to grant, and do by these Letters of Registration grant unto the said Frank Wright and Matthew William Wallbank Mackie, their executors, administrators, and assigns, the exclusive enjoyment and advantage of the said invention or improvement, for and during the term of fourteen years from the date hereof; to have, hold, and exercise unto the said Frank Wright and Matthew William Wallbank Mackie, their executors, administrators, and assigns, the exclusive enjoyment and advantage thereof, for and during and unto the full end and term of fourteen years from the date of these presents next and immediately ensuing, and fully to be complete and ended: Provided always, that if the said Frank Wright and Matthew William Wallbank Mackie shall not, within three days after the granting of these Letters of Registration, register the same in the proper office in the Supreme Court, at Sydney, in the said Colony of New South Wales, then these Letters of Registration, and all advantages whatsoever hereby granted, shall cease and become void.

In witness whereof, I have hereunto set my sign manual, and have caused the present Letters of Registration to be sealed with the seal of the said Colony of New South Wales, at Government House, Sydney, in New South Wales, this second day of January, in the year of our Lord one thousand eight hundred and eighty-three.

[L.S.]

AUGUSTUS LOFTUS.



---

*Improved Apparatus for blowing and shaping Glass.*

---

SPECIFICATION of FRANK WRIGHT and MATTHEW WILLIAM WALLBANK MACKIE, both of No. 80, Gray's Inn Road, in the county of Middlesex, England, electrical engineers, for an invention entitled, "A new or improved Apparatus for blowing and shaping Glass."

OUR invention relates to apparatus for blowing and shaping glass, heated by the blow-pipe, to forms which are usually those of solids of revolution, the object which we have in view being to ensure equable heating of the glass, and to hold it and move it without undue strains while it is being operated on, so that it can be readily manipulated by comparatively unskilled operatives. The accompanying drawings show the apparatus which we employ for this purpose, figure 1 being a side view, figure 2 a plan, and figure 3 a transverse section on ZZ.

On a bed, A, like that of an ordinary lathe, we fit two headstocks, B and C, one of which, B, may be fixed, and the other, C, capable of being slid to and fro by a rack and pinion worked by a handle, D. In bearings in each of the headstocks is fitted a tubular mandril, E and F, of which E is driven by a belt or otherwise, and F by gearing from E, so as to revolve at the same speed. The gearing for this purpose consists of a pinion, *e*, driven from a wheel on E, a horizontal spindle, G, and on it another pinion, *f*, driving a wheel on F. The pinion *f* is fitted with a key or feather on the spindle G, so that it must revolve with it, but may slide freely along it with the headstock C. At the end of each headstock is fixed a tube, H and K, closed at their outer ends, but communicating freely with the respective tubular mandrils, and to each of the tubes H and K there is a communication by a flexible tube, *h* and *k*, from a reservoir of compressed air, each of those communications being provided with a cock or valve, so that the operator can open or close it at pleasure. Between the two headstocks, B and C, is fitted a slide, M, that can be moved along the bed by a rack and pinion, worked by a handle, N. On this slide is fitted a transverse slide, O, carrying a blow pipe, P, which may be double, as shown, supplied with gas and air by flexible pipes, *p*, each pipe being provided with a cock or valve, so that the quantity of air and gas can be regulated by the operator. The blow-pipe P is fitted to turn on a vertical axis on the slide O, so that the flames can be directed on the glass at any desired angle. Each of the mandrils E and F has at its front end a chuck, R and S, which is lined internally with soft or elastic packing material, such as leather, felt, or caoutchouc, capable of clamping a glass tube without unequal strain, and at the same time preventing escape of air from the hollow mandril. The apparatus is worked in the following manner:— A glass rod or tube, T, is inserted into and clamped in the two chucks, R and S, and caused to revolve. The blow-pipe flame is directed on any part of it, and the part thus heated can be drawn out thinner or set up thicker by moving the headstock C away from or towards B. By admitting air under pressure into either or both the tubes, H K, the glass tube can be blown at the heated part into a bulb, which can be elongated or flattened by moving the headstock, C. Again, if it be desired to join two glass rods or tubes, each is clamped in one of the chucks R and S; the free ends are brought together, and being heated, can be joined. And it is obvious that pieces of glass held as described, and caused to revolve under the influence of the blow-pipe flame, can be variously shaped or moulded, separated, or joined, as may be desired.

Having thus described the nature of our invention, and in what manner the same is to be performed, we claim:—

For shaping heated glass, the use of apparatus, wherein two tubular mandrils, provided with chucks to receive glass rods or tubes, and with pipes supplying their interiors with compressed air, are caused to revolve simultaneously, while the headstocks carrying the chucks can be moved nearer together or farther apart on a bed, on which is fitted an intermediate blow-pipe slide, arranged and operating substantially as herein described.

In witness whereof, we, the said Frank Wright and Matthew William Wallbank Mackie, have hereunto set our hands and seals, this twenty-first day of September, in the year of our Lord one thousand eight hundred and eight-two.

Witness—

OLIVER IMRAY,  
28, Southampton Buildings, London, W.C.

FRANK WRIGHT.  
M. W. W. MACKIE.

This is the specification referred to in the annexed Letters of Registration granted to Frank Wright and Matthew William Wallbank Mackie, this second day of January, A.D. 1883.

AUGUSTUS LOFTUS.

---

REPORT.

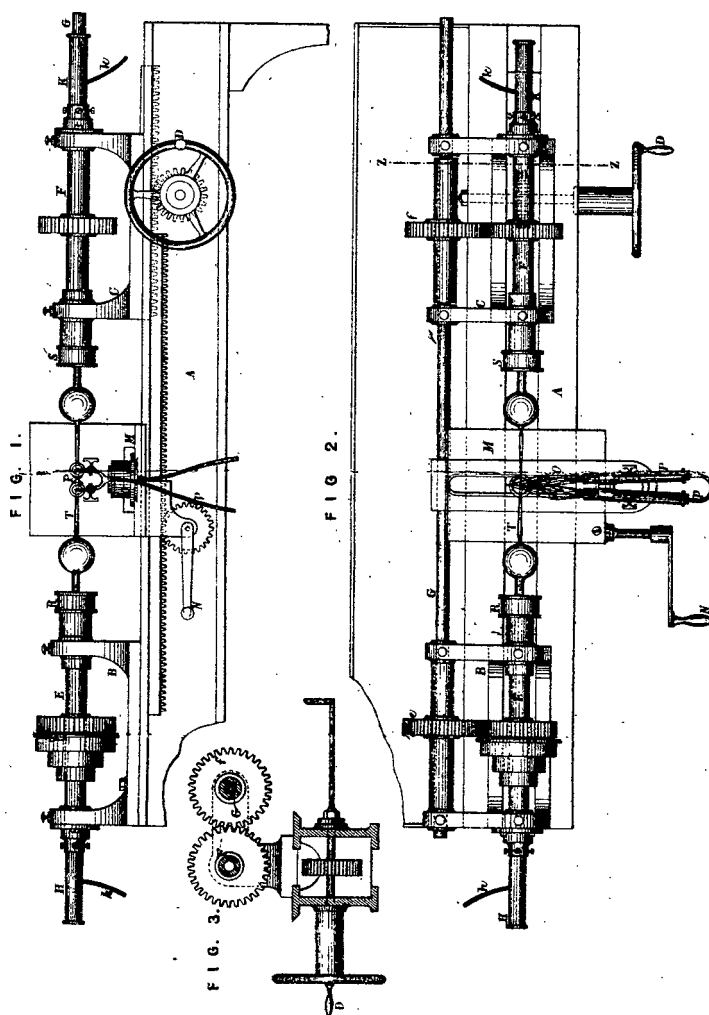
---

Sir,

The application of Messrs. Frank Wright and Matthew William Wallbank Mackie for an invention entitled "A new or improved Apparatus for blowing and shaping Glass," having been referred to us, we have examined the specification and drawings accompanying the same, and have the honor to report that we see no objection to the issue of Letters of Registration as prayed for.

We have, &c.,  
A. LEIBIUS.  
CHAS. WATT.

The Under Secretary of Justice.



*This is the Sheet of Drawings referred to in the annexed  
Letters of Registration granted to Frank Wright and  
Matthew William Wallbank Mackie this second day of  
January A.D. 1883.*

*Augustus Loftus.*



A.D. 1883, 2nd January. No. 1177.

IMPROVEMENTS IN SPRING-HANDLE CRICKET BATS.

LETTERS OF REGISTRATION to James Chalmers Brodie, for Improvements in Spring-handle Cricket Bats.

[Registered on the 5th day of January, 1883, in pursuance of the Act 16 Vic. No. 24.]

BY HIS EXCELLENCY THE RIGHT HONORABLE SIR AUGUSTUS WILLIAM FREDERICK SPENCER LOFTUS (commonly called LORD AUGUSTUS LOFTUS), Knight Grand Cross of the Most Honorable Order of the Bath, a Member of Her Majesty's Most Honorable Privy Council, Governor and Commander-in-Chief of the Colony of New South Wales and its Dependencies.

TO ALL TO WHOM THESE PRESENTS SHALL COME, greeting :

WHEREAS JAMES CHALMERS BRODIE, of Adelaide, in the Province of South Australia, gentleman, hath by his Petition humbly represented to me that he is the author or designer of a certain invention or improvement in manufactures, that is to say, of an invention entitled "Improvements in Spring-handle Cricket Bats," which is more particularly described in the specification and the sheet of drawings which are hereunto annexed; and that he, the said Petitioner, hath deposited with the Honorable the Treasurer of the said Colony of New South Wales the sum of Twenty Pounds sterling, for defraying the expense of granting these Letters of Registration, as required by the Act of Council, sixteenth Victoria, number twenty-four; and hath humbly prayed that I would be pleased to grant Letters of Registration, whereby the exclusive enjoyment and advantage of the said invention or improvement might be secured to him for a period of fourteen years: And I, being willing to give encouragement to all inventions and improvements in the arts or manufactures which may be for the public good, and having received a report favourable to the prayer of the said Petition, from competent persons appointed by me to examine and consider the matters stated therein and to report thereon for my information, am pleased, with the advice of the Executive Council, and in exercise of the power and authority given to me by the said Act of Council, to grant, and do by these Letters of Registration grant unto the said James Chalmers Brodie, his executors, administrators, and assigns, the exclusive enjoyment and advantage of the said invention or improvement, for and during the term of fourteen years from the date hereof; to have, hold, and exercise unto the said James Chalmers Brodie, his executors, administrators, and assigns, the exclusive enjoyment and advantage thereof, for and during and unto the full end and term of fourteen years from the date of these presents next and immediately ensuing, and fully to be complete and ended: Provided always, that if the said James Chalmers Brodie shall not, within three days after the granting of these Letters of Registration, register the same in the proper office in the Supreme Court at Sydney, in the said Colony of New South Wales, then these Letters of Registration, and all advantages whatsoever hereby granted, shall cease and become void.

In witness whereof, I have hereunto set my sign manual, and have caused the present Letters of Registration to be sealed with the seal of the said Colony of New South Wales, at Government House, Sydney, in New South Wales, this second day of January, in the year of our Lord one thousand eight hundred and eighty-three.

[L.S.]

AUGUSTUS LOFTUS.

*Improvements in Spring-handle Cricket Bats.*

## SPECIFICATION.

TO ALL TO WHOM THESE PRESENTS SHALL COME, I, JAMES CHALMERS BRODIE, of Adelaide, in the Province of South Australia, gentleman, send greeting :

WHEREAS, I, the said James Chalmers Brodie, am the inventor of certain improvements for "Improvements in spring-handle cricket bats": Now know ye that I, the said James Chalmers Brodie, do hereby declare the nature of my said improvements, and in what manner the same are to be prepared, to be particularly described and ascertained in and by the following statement, that is to say:—My invention consists of a new method of making cricket bat handles springy and so increasing their driving power at much less cost than the spring-handle bats ordinarily in use. My drawings, deposited herewith, show samples of cricket bats, and illustrate the manner in which my invention is applied, but of course it can be used in other ways and according to the degrees of elasticity which may be required. Drawing No. 1 shows a bat with the handle in one piece; it will be seen, however, that the weight of the solid handle is reduced by its being made hollow and the hollow being filled with cork or some light material. The weight altogether will not exceed that of an ordinary spring-handle bat, and the cost thereof is reduced at least one half. The handle is to be made of springy hardwood such as American or English hickory or ash. The weight is reduced by boring with  $\frac{3}{8}$  or  $\frac{7}{8}$  auger down the centre of handle, as far as may be necessary, and the handle is well fitted and glued in the pod. To increase the spring if necessary, a half-inch auger hole is made in the side of the handle immediately above the pod, and another similar perforation (say) from 1 to 6 inches up the handle of the bat, and the intervening timber is removed.

To prevent the sound the cavity is filled up with cork or some light and pliant material so as not to increase the weight or interfere with the springyness of the handle. To give the handle still greater spring if necessary, a small piece (say) from  $\frac{1}{2}$  up to 3 inches may be removed from the back of the handle, as in Drawing No. 2, commencing from immediately above the shoulder of the bat, and something of a springy nature may be inserted, such as a V or spiral spring of steel. The variety of plans of reducing the weight and increasing the springyness of such handles may be indefinitely multiplied and so reduced or intensified to suit the style of any player. Drawing No. 3 illustrates my plan of improving and strengthening any bat, from the common bat all in one piece to the very best spring-handle bat, by inserting a piece of solid hickory, or any other such hard and springy substance so as to strengthen the handle, and, if necessary, to increase its elasticity and driving power, the elasticity to be determined according to the style of the player, a hard hitter requiring only sufficient spring in the handle to prevent a jar; and for one who simply guards his wicket or cuts and slips, the spring may be very much increased without detriment to its durability. In this bat the hickory is inserted in the centre of the handle from 4 to 6 inches into the pod, the upper end of the handle being filled up with cork or other light material so as to maintain the balance of the bat without materially increasing the weight.

Claims: Having now fully described my invention and the manner in which it is applied, I wish it to be distinctly understood that what I claim as my invention is:—

First—The method of making the spring-handle of a cricket bat in one piece, substantially as shown in Drawing No. 1.

Second—The method of increasing the spring of a cricket bat by cutting the handles, substantially as shown in Drawing No. 2, and inserting or not, as circumstances may require, a steel or other spring, or piece of elastic material.

Third—The method of giving additional spring to a cricket bat by the insertion of a piece of hickory, ash, or other springy wood down the centre of the handle into the pod of the bat, substantially as shown in Drawing No. 3.

In witness whereof, I have hereunto set my hand and seal, this thirteenth day of November, in the year of our Lord one thousand eight hundred and eighty-two.

JAS. CHA. BRODIE.

Witness—

Jno. FAIRFAX CONIGRAVE,  
Licensed Patent Agent, Waymouth-street, Adelaide.

This is the specification referred to in the annexed Letters of Registration granted to James Chalmers Brodie, this 2nd day of January, A.D. 1883.

AUGUSTUS LOFTUS.

## REPORT.

Sir,

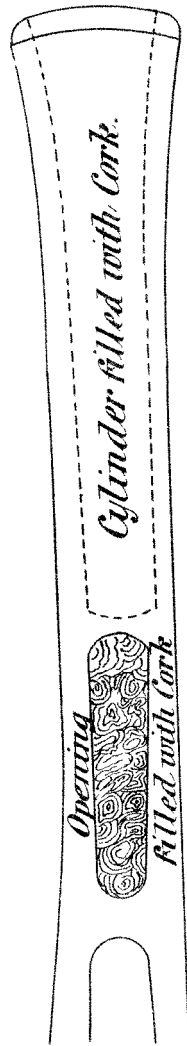
The application of J. C. Brodie, for Letters of Registration for an invention entitled "Improvements in Spring-handled bats," having been referred to us for report, we have examined the plan and specification accompanying the same, and have now the honor to report that we see no objection to the issue of Letters of Registration as applied for.

We have, &c.,  
ARCH. FRASER.  
THOS. RICHARDS.

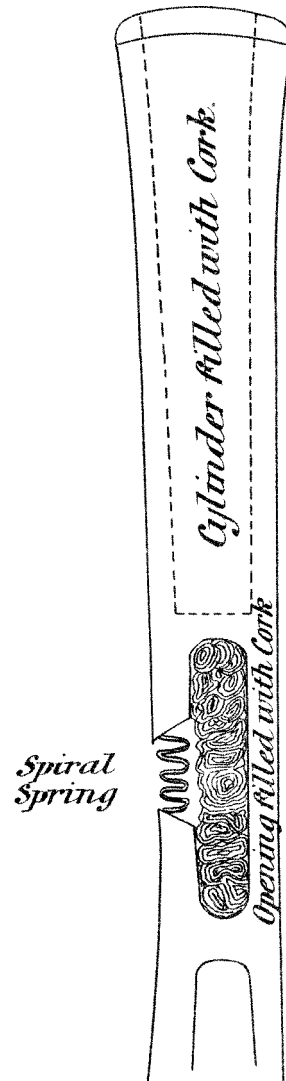
The Under Secretary of Justice.

SIDE VIEWS.

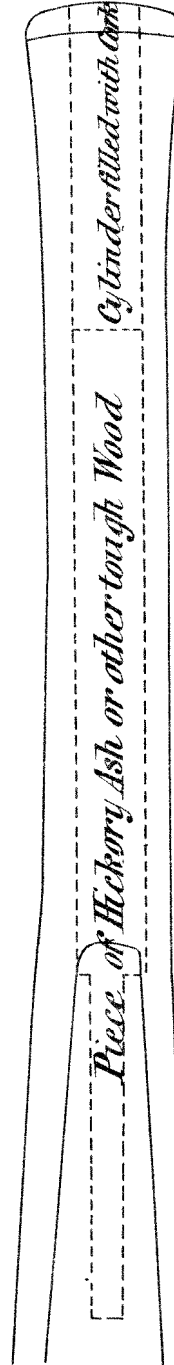
N<sup>o</sup> 1.



N<sup>o</sup> 2.

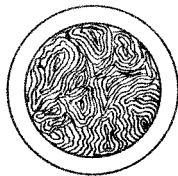


N<sup>o</sup> 3.

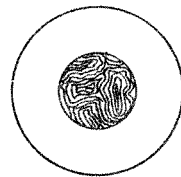


END VIEWS

N<sup>o</sup> 1 & 2.



N<sup>o</sup> 3.



*This is the Sheet of Drawings referred to in the annexed  
Letters of Registration granted to James Chalmers  
Brodie this 2<sup>nd</sup> day of January A D. 1883.*

*Augustus Loftus.*

*Witnessed  
J. W. Fairfax & Co. Agents  
Licensed Patent Agents  
Wojmantsch & Adelaide.*

*J. W. Chalmers & Brodie.*



A.D. 1883, 2nd January. No. 1178.

IMPROVED MEANS OF LOCKING NUTS.

LETTERS OF REGISTRATION to Henry Bezer, for Improved Means of Locking Nuts.

[Registered on the 5th day of January, 1883, in pursuance of the Act 16 Vic. No. 24.]

BY HIS EXCELLENCY THE RIGHT HONORABLE SIR AUGUSTUS WILLIAM FREDERICK SPENCER LOFTUS (commonly called LORD AUGUSTUS LOFTUS), Knight Grand Cross of the Most Honorable Order of the Bath, a Member of Her Majesty's Most Honorable Privy Council, Governor and Commander-in-Chief of the Colony of New South Wales and its Dependencies.

TO ALL TO WHOM THESE PRESENTS SHALL COME, greeting:

WHEREAS HENRY BEZER, of No. 190, Westminster Bridge Road, Surrey, in England, engineer, hath by his Petition humbly represented to me that he is the author or designer of a certain invention or improvement in manufactures, that is to say, of an invention entitled "Improved Means of Locking Nuts," which is more particularly described in the specification and the sheet of drawings which are hereunto annexed; and that he, the said Petitioner, hath deposited with the Honorable the Treasurer of the said Colony of New South Wales the sum of Twenty Pounds sterling, for defraying the expense of granting these Letters of Registration, as required by the Act of Council, sixteenth Victoria, number twenty-four; and hath humbly prayed that I would be pleased to grant Letters of Registration, whereby the exclusive enjoyment and advantage of the said invention or improvement might be secured to him for a period of fourteen years: And I, being willing to give encouragement to all inventions and improvements in the arts or manufactures which may be for the public good, and having received a report favourable to the prayer of the said Petition, from competent persons appointed by me to examine and consider the matters stated therein and to report thereon for my information, am pleased, with the advice of the Executive Council, and in exercise of the power and authority given to me by the said Act of Council, to grant, and do by these Letters of Registration grant unto the said Henry Bezer, his executors, administrators, and assigns, the exclusive enjoyment and advantage of the said invention or improvement, for and during the term of fourteen years from the date hereof; to have, hold, and exercise unto the said Henry Bezer, his executors, administrators, and assigns, the exclusive enjoyment and advantage thereof, for and during and unto the full end and term of fourteen years from the date of these presents next and immediately ensuing, and fully to be complete and ended: Provided always, that if the said Henry Bezer shall not, within three days after the granting of these Letters of Registration, register the same in the proper office in the Supreme Court, at Sydney, in the said Colony of New South Wales, then these Letters of Registration, and all advantages whatsoever hereby granted, shall cease and become void.

In witness whereof, I have hereunto set my sign manual, and have caused the present Letters of Registration to be sealed with the seal of the said Colony of New South Wales, at Government House, Sydney, in New South Wales, this second day of January, in the year of our Lord one thousand eight hundred and eighty-three.

[L.S.]

AUGUSTUS LOFTUS.

*Improved Means of Locking Nuts.*

SPECIFICATION of HENRY BEZER, of No. 190, Westminster Bridge Road, Surrey, in England, engineer, for an invention entitled "Improved Means of Locking Nuts."

THE object of my invention is to provide more efficient means of locking nuts, and consists essentially in the employment of a wire, a nail, or other suitable strip of metal in combination with a groove or recess in the nut to be locked, and with a groove or recess in the face of the plate or other thing against which said nut is to be locked, the said wire, nail, or strip being inserted into said grooves or recesses when the nut is slack, and the tightening up of the nut causing the wire, nail, or strip to be drawn into the nut and round the bolt, so that it forms a lock.

Figures 1 to 6 of the annexed drawings represent my invention applied to locking the nuts on the fastening bolts of a railroad fish joint or splice. Figure 1 is a side view of the joint, and figure 2 a section on the line 1 2. Figure 3 is a full size view of part of the outer face of the plate C, and figure 4 a section on the line 3 4. Figure 5 is a full size view of the inside face of the nut, and figure 6 a section on the line 5 6.

AA are the two rails to be joined or spliced; BC are the two fish-plates on the opposite side of the rails respectively; DD are the fastening bolts passing through holes in the plates; BC in the ordinary manner; E<sup>1</sup> E<sup>2</sup> E<sup>3</sup> E<sup>4</sup> are the nuts.

In the outer face of the plate C, at the side of each bolt-hole, I form a groove or recess F which tapers off at the upper part as seen in figure 4.

In the inner face of each nut I form a groove or recess G around the central hole or orifice, and this groove at one, two, or more points (the drawings show two) extends to the outer edge of the nut in the form of a gap HH.

I I represent the locking wires.

The action or operation is as follows:—The fish-plates having been applied, the bolts inserted, and the nuts screwed up tight in the usual manner, the nuts are then (one at a time) slacked back until one of the gaps H is opposite the groove F in the plate C, as shown at the nut E<sup>1</sup>, figure 1. The wire I is then inserted through the gap into the groove F, as also seen at the nut E<sup>1</sup>. The nut is then screwed up tight again, the result of which is that the wire I is drawn into the groove G of the nut and round the bolt, the bottom portion of the wire remaining in the groove F of the fish-plate (see nuts E<sup>1</sup> E<sup>2</sup> E<sup>3</sup>). The nut is thus locked in position, and cannot become loose without uncoiling the wire.

In practice, I have found it desirable before inserting the locking-wires to tighten the nuts in the ordinary way for about three weeks, in order that the plates may become fairly bedded. Then I slack back the nuts and insert the wires as already explained.

Figures 7 to 11 illustrate the manner in which I apply my invention in cases where a nut is used to lock or check another nut. Figures 7 and 8 are views taken at right angles to each other of the bolt, nut, and check nut. Figure 9, an end view of the same. Figure 10, a section of the inner or first nut, and figure 11, a view of the locking nail or wire.

D is the bolt, C the inner nut, E the check-nut, F a circular groove in that face of the nut C which comes in contact with the nut E; G is a corresponding groove in the face of the nut E.

H is a hole in the nut C, parallel to its axis. H<sup>1</sup> a similar hole in the nut E.

I is the nail or wire. It should be considerably longer than the combined thickness of the two nuts, and I prefer to use what is called a "French" nail.

The action is as follows:—The nail I is passed through the holes H H<sup>1</sup> in the two nuts, which are then with the nail, as it were, loosely connecting them screwed upon the bolt D until the nut C is in the required position, or in contact with the object to be fastened. Then the nut C is held by a spanner or otherwise, and the nut E is forced round the bolt D by means of another spanner, the result being that the nail I becomes bent, and the bent portion will, as seen in figures 7 and 8, occupy so much of the grooves F and G as is between the two holes H and H<sup>1</sup> in their now altered relative positions. The nail thus forms a lock. The projecting end may be removed by a suitable tool.

What I claim as my invention is—

First—The method of locking nuts by means of a wire, nail, or strip of metal, which, when the nut is slack, is inserted partly into a recess in the nut, and partly into a recess in the plate or other thing against which said nut is to be locked, and which wire, nail, or strip, when the nut is screwed up tight, becomes bent and drawn into the nut and thereby forms a lock substantially as herein set forth.

Second—The locking wire, nail, or strip I, in combination with the grooves or recesses F and G and gaps or openings H substantially as herein described and shown.

In witness whereof, I, the said Henry Bezer, have hereto set my hand and seal, this first day of November, one thousand eight hundred and eighty-two.

Witness—

U. S. BAYSTON.

HENRY BEZER,  
By his duly authorized Attorney,  
EDWD. WATERS.

This is the specification referred to in the annexed Letters of Registration granted to Henry Bezer, this 2nd day of January, A.D. 1883.

AUGUSTUS LOFTUS.

---

*Improved Means of Locking Nuts.*

---

REPORT.

Sir, With reference to your letter of the 8th instant, enclosing specification and drawings of "Improved Means of Locking Nuts," for which Letters of Registration were applied for on behalf of Mr. Henry Bezer, of No. 190, Westminster Bridge Road, London, we see no reason why such protection should not be granted.

The Under Secretary of Justice.

Sydney, 16 November, 1882.

We have, &c.,

JAMES BARNET.

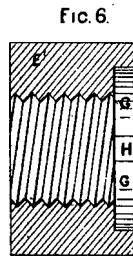
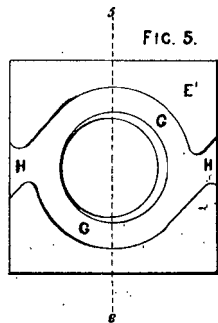
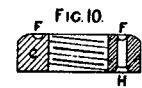
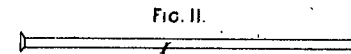
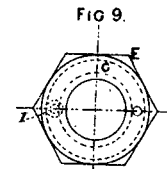
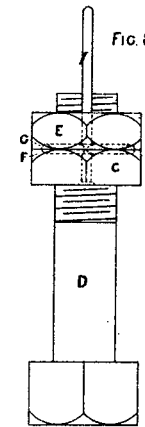
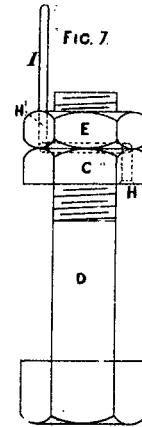
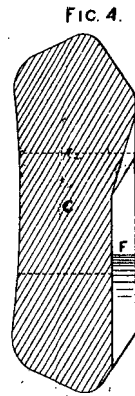
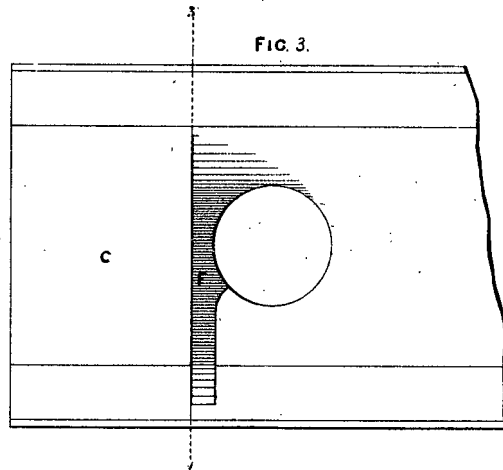
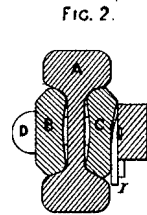
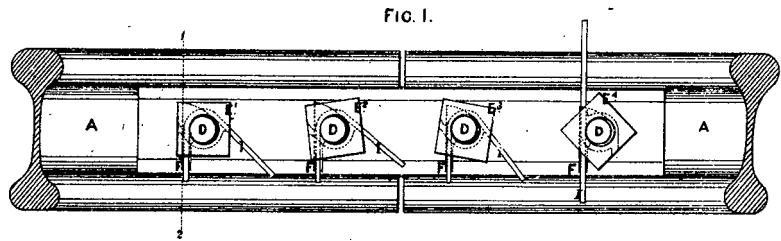
WILLIAM C. BENNETT.

---

[Drawings—one sheet.]



### H. BEZER'S PATENT LOCK NUT.



*This is the Sheet of Drawings referred to in the annexed Letters of Registration granted to Henry Bezer this second day of January A.D. 1883.*

*Augustus Loftus.*



A.D. 1882, 19th January. No. 1179.

IMPROVEMENTS IN ELECTRIC LAMPS.

LETTERS OF REGISTRATION to William Crookes, for Improvements in the Construction and Manufacture of Electric Lamps.

[Registered on the 19th day of January, 1883, in pursuance of the Act 16 Vic. No. 24.]

BY HIS EXCELLENCY THE RIGHT HONORABLE SIR AUGUSTUS WILLIAM FREDERICK SPENCER LOFTUS (commonly called LORD AUGUSTUS LOFTUS), Knight Grand Cross of the Most Honorable Order of the Bath, a Member of Her Majesty's Most Honorable Privy Council, Governor and Commander-in-Chief of the Colony of New South Wales and its Dependencies.

TO ALL TO WHOM THESE PRESENTS SHALL COME, greeting:

WHEREAS WILLIAM CROOKES, F.R.S., of Boy Court, Ludgate Hill, in the City of London, England, hath by his Petition humbly represented to me that he is the author or designer of a certain invention or improvement in manufactures, that is to say, of an invention entitled "Improvements in the Construction and Manufacture of Electric Lamps," which is more particularly described in the specification marked "A," and the two sheets of drawings marked "B" and "C" respectively, which are hereunto annexed; and that he, the said Petitioner, hath deposited with the Honorable the Treasurer of the said Colony of New South Wales the sum of Twenty Pounds sterling, for defraying the expense of granting these Letters of Registration, as required by the Act of Council, sixteenth Victoria, number twenty-four; and hath humbly prayed that I would be pleased to grant Letters of Registration, whereby the exclusive enjoyment and advantage of the said invention or improvement might be secured to him for a period of fourteen years: And I, being willing to give encouragement to all inventions and improvements in the arts or manufactures which may be for the public good, and having received a report favourable to the prayer of the said Petition, from competent persons appointed by me to examine and consider the matters stated therein and to report thereon for my information, am pleased, with the advice of the Executive Council, and in exercise of the power and authority given to me by the said Act of Council, to grant, and do by these Letters of Registration grant unto the said William Crookes, his executors, administrators, and assigns, the exclusive enjoyment and advantage of the said invention or improvement, for and during the term of fourteen years from the date hereof; to have, hold, and exercise unto the said William Crookes, his executors, administrators, and assigns, the exclusive enjoyment and advantage thereof, for and during and unto the full end and term of fourteen years from the date of these presents next and immediately ensuing, and fully to be complete and ended: Provided always, that if the said William Crookes shall not, within three days after the granting of these Letters of Registration, register the same in the proper office in the Supreme Court, at Sydney, in the said Colony of New South Wales, then these Letters of Registration, and all advantages whatsoever hereby granted, shall cease and become void.

In witness whereof, I have hereunto set my sign manual, and have caused the present Letters of Registration to be sealed with the seal of the said Colony of New South Wales, at Government House, Sydney, in New South Wales, this nineteenth day of January, in the year of our Lord one thousand eight hundred and eighty-three.

[L.S.]

AUGUSTUS LOFTUS.

*Improvements in Electric Lamps.*

SPECIFICATION of WILLIAM CROOKES, F.R.S., of Boy Court, Ludgate Hill, in the City of London, England, for an invention entitled "Improvements in the Construction and Manufacture of Electric Lamps."

My invention has for its object improvements in the construction and manufacture of electric lamps of the type known as incandescent lamps, or those in which the light is produced by heating a conductor of small section and high resistance to incandescence; and some portions of it are also applicable to the manufacture of carbons, for use in other kinds of electric lamps.

In the preparation of carbon in the form of filaments and thin rods for the incandescent light, or in the form of rods and bars for the arc light, it is important that the carbon should be as pure as possible.

The chief source of impurity is the inorganic constituents, or "ash."

In the incandescent lamp of Swan, Edison, Maxim, Lane-Fox, and others, a filament of vegetable fibre or cellulose, either natural (as bamboo fibres) or in a manufactured state (as thread paper, or parchment paper), is carbonised in a space free from oxygen, by which the oxygen and hydrogen of the cellulose are driven off and the carbon is left behind.

Carbon is infusible and unaltered at very high temperatures.

The inorganic constituents of the cellulose, consisting, amongst other things, of silica, iron, lime, and other bases, are not driven off by heat during the process of carbonisation, and remain with the carbon.

These impurities are injurious in various ways; they cause the glass to become dim and the carbon to disintegrate, and finally to break. If the temperature does not rise to the reducing point of the oxides the silicates fuse and coat the particles of carbon, interfering with its conductivity, with its radiating and emissive power for light, and with the deposition of fresh carbon from the decomposition of hydro-carbons.

In the arc light the carbon burns away, and the silicates and other constituents of the ash fuse and accumulate till they fall off, causing temporary stoppage or flickering of the light; or the constituents of the ash decompose and volatilise, colouring the electric light irregularly and in an unpleasant manner.

All these inconveniences I obviate by previously removing the constituents of the ash. This may be done either while the material is in the undecomposed state or after carbonisation.

In the former case I take the fibre of bamboo, hemp, linen, paper, thread (whether parchmented or not), or other form of cellulose, or other body containing carbon, from which it is intended to manufacture the carbon, and allow it to soak in hydrofluoric acid until a sample, removed and washed free from the acid, leaves very little or no inorganic ash upon being burnt. A little hydrochloric or other acid may be added to increase the solvent power upon the constituents of the ash other than silica, care being taken that it is not sufficiently strong to attack the cellulose itself.

Instead of using hydrofluoric acid, a mixture of a fluoride, such as fluoride of calcium or fluoride of sodium, and an acid capable of liberating hydrofluoric acid from it (but not of attacking the cellulose) may be used, or the substance to be operated on may be exposed to the vapour of hydrofluoric acid, as usually generated by acting on fluor-spar by oil of vitriol, or any other equivalent method of exposing the substance to the action of hydrofluoric acid may be employed.

After being acted upon for a sufficient length of time, the material must then be well washed in pure water, so as to be free from acid.

If it is desired to operate on the material after carbonisation, it is necessary that the carbon should be in the form of a fine powder, or in extremely thin filaments or sheets, such as those produced by carbonising thread, paper, or the skin of cellulose, prepared by the method hereinafter described. The process is then the same as that above described, and the carbon may afterwards be made up into discs, sticks, or rods, for use in arc lamps, or other lamps in which carbon discs, sticks, or rods are used. It is not practicable to act upon the sticks themselves, as their thickness and density would prevent the success of the process.

The inorganic ash may also be removed from the carbon by heating it to redness or whiteness, in a suitable vessel containing free chlorine, through which a current of free chlorine is passed. If free oxygen, or an oxidising atmosphere be present at the commencement of the operation, the carbon will remove the oxygen by combining with it in the process of combustion; but it is preferable to remove it before the operation commences. Hydrochloric acid will act in a similar way to free chlorine, but less energetically. The carbon must be in the same state as previously described, in order to ensure its being completely purified by the chlorine or hydrochloric acid.

In order to obtain a carbon filament of great homogeneity, density, and elasticity, for use in an incandescent lamp, I take some convenient form of cellulose, such as paper, cotton, linen, or cotton wool, and, having purified it, if necessary, from silica and other inorganic impurities by the method above described, I treat it with a solution of oxide of copper, in ammonia, in order to effect a solution of the cellulose.

If I operate upon cellulose in the form of paper, linen, thread, or other like forms, in which the substance has sufficient strength and continuity, I wait until the liquid has acted upon the cellulose to such an extent as to wholly or partially destroy its intimate structure, but not sufficiently to produce disintegration of the substance. I then take it out of the liquid and allow the ammonia to evaporate, after which I dissolve out the copper that remains, by the aid of dilute sulphuric or other suitable acid, and then wash the substance thoroughly with water, and let it dry, under pressure, between sheets of absorbent material, such as blotting paper.

I prefer, however, to take a looser form of cellulose, such as cotton wool, and to allow it to remain in the solvent until it is entirely dissolved, or nearly so. I then pour the liquid out into a very shallow dish, with an accurately levelled plane bottom. The ammonia is allowed to evaporate, leaving a film or skin of the dissolved cellulose covering the bottom of the dish, the thickness of this film depending on the original depth of the fluid and the percentage of dissolved cellulose therein. This film or skin, when it has acquired a sufficient consistency by the evaporation of the ammonia, is treated with dilute sulphuric or other acid to extract the copper, and is then thoroughly washed with water, and dried, under pressure, between sheets of absorbent material, such as blotting paper.

The

*Improvements in Electric Lamps.*

The sheets or threads thus made give, when carbonised, a carbon of great density, hardness, elasticity, and homogeneity, admirably adapted for the filaments of incandescent lamps. By making such carbon in the shape of rods, discs, or plates of a suitable thickness, instead of sheets, it can be used in other forms of electric lamps, or in batteries which make use of carbon.

It is not necessary to extract the copper before carbonisation, as it is easy to extract it by acids afterwards. I find it a great advantage to permit the copper to remain in the parts of the filament near to its extremities, inasmuch as thereby the conductivity is improved, and the heating near the junction of the filament and the conducting wires diminished. The copper may also be extracted by being volatilised, by passing a strong electric current through the filament so as to raise it to a sufficiently high temperature in a vacuum or a gas not acting upon the carbon.

I usually make the carbon filaments for my lamps by cutting or punching out pieces of a convenient form from the sheets before carbonisation. The most convenient methods are to cut a thin strip from the sheet before it is quite dry, and to twist it several times so as to make a thread; or to bend a narrow strip into the shape of an elongated **U**, or to fold it so as to form a right angle at each of two points near the centre, so that the main part of it consists of two equal legs, parallel to and at a short distance from one another. Other shapes may be adopted, the folding being done when necessary before the material is fully dry, in which case it readily adopts and retains almost any desired shape.

The carbonisation of the filaments prepared by the above processes must be effected slowly. It may be done by any of the ordinary methods, preferably in a gas muffle furnace. Air must be wholly excluded, and the filaments should be carbonised, under pressure, between blotting paper.

In order to make a good junction between the extremities of the carbon filament and the conducting wires, I have three methods, which may be used separately or together. By the one I electro-plate, with copper, nickel, platinum, or other suitable metal, the extremities of the carbon filament to the distance of a few millimetres, and fix these extremities to the ends of the conducting wires, either by binding them together by thin wire or by pinching the extremities of the filament into the ends of the conducting wires (which are split a few millimetres down for that purpose), or by putting the extremities of the filament into small metal clips, fixed on the ends of the conducting wires; if necessary the junctions may be also bound round with thin wire. I then thickly electro-plate the whole of each of the junctions, including a few millimetres' length of the conducting wire, and a millimetre or two of each end of the filament with copper, nickel, platinum, or other suitable metal. By the second method, I take a thick syrupy solution of cellulose, in the ammoniacal oxide of copper solution, above referred to, and having connected the extremities of the filament to the ends of the conducting wires by the former or any other convenient method, I paint the solution thickly over the junctions till it forms a mass of sufficient size. As the ammonia evaporates the mass becomes solid, and the junctions must then be carbonised, either by placing temporarily the filament thus mounted in an exhausted bulb, or the receiver of an air-pump, fitted as subsequently described, and passing a strong electric current through it, so that the heat given off by the filament may carbonise the junctions, or, in the ordinary manner, by the direct application of heat. By the third method, I take the cellulose skin or other material, from which the carbon filament is to be prepared, and, having cut it to the required shape, I connect the extremities with the conducting wires before carbonisation, by either of the methods above described. I then carbonise the cellulose or other material by heating it in an atmosphere free from oxygen—by preference, a hydrocarbon vapour. If desirable, the junctions may be now strengthened by the electro-deposition thereon of metal, as already described.

In order to form the glass enclosure of the lamp, I take a cylinder of glass of any convenient size, and after drawing down one end in the blow-pipe I draw the other end out into a wide neck, and seal off its end in the blow-pipe, the neck will then have been brought approximately to the form shown at **A**, figure 1. While the glass neck is still hot, or after reheating it, I press the end inwards with a two-pointed metal tool like a two-pronged fork, which may be of the shape shown in figure 2, so as to make a hollow projection, **B**, stretching a convenient distance into the neck of the tube, and terminating in two hollow points of glass. The tube then has the appearance shown in figure 3.

At this or some other convenient stage of the process a small glass tube, **C**, shown in dotted lines in figure 3, is sealed on to the lamp (preferably at the lower edge, where the glass is bent inwards) for the purpose of exhausting the lamp and filling it with a suitable protective atmosphere, if such is desired. It is desirable that the mouth of the drawn down end of the cylinder should be previously sealed, as shown by the dotted line **D**, so as to facilitate the blowing on of the tube. If this tube be sealed on to the lamp at this stage it will present the appearance shown in figure 3, but it is not necessary that the small tube last described should have the particular position there shown. The top of the lamp should now be sealed off before the blow-pipe, and formed into a hemispherical end, as shown by the dotted line **E**. It is not, however, necessary that this should be done at this stage, but any other convenient stage of the process may be selected for doing it.

When the glass is cool I cut the tube in two, across the neck, at such a distance from the end as to leave the two glass points projecting from the bottom piece of the tube, as shown at figure 4. This division of the tube may easily be effected by slightly scratching it with a file, or cutting with a diamond, and applying a hot iron or hot piece of glass. When this has been done the two hollow points at the top of the projection, **B**, are opened in the blow-pipe, or by breaking off their ends, or in any other convenient way, and conducting wires are passed through the openings so made, and then sealed in the glass by means of white enamel, or what is technically known as arsenic glass. If platinum wires are used to pass through the glass for the purpose of acting as conducting wires, they can be sealed into the glass in the usual way without the use of such enamel. The most convenient method of fixing the wires in the lamp is to coat them with enamel or arsenic glass, and to pass each wire through a separate short cylinder of glass of small section, and heating it in the blow-pipe so as to melt the glass and enamel, and thus seal them together. A conducting wire, having a short cylinder of glass so sealed on to it, is shown at figure 5.

The wire is now passed through the open point of the glass projection above mentioned until the glass cylinder on the wire rests against the end of the glass projection, and the two are then sealed together in the blow-pipe, either with or without the interposition of arsenic glass or enamel. The parts will then have the appearance shown in figure 6. The

*Improvements in Electric Lamps.*

The carbon filament can now be attached to the conducting wires, afterwards the two portions of the tube forming the lamp are sealed together in the blow-pipe, at the place where the tube was cut open. The lamp is now in a fit condition for exhaustion, which is effected through the small tube which has been sealed on to it for the purpose; and when the exhaustion has been effected, this tube is sealed off preferably close to the point of junction with the lamp. The finished lamp then presents the appearance shown in figure 7.

The hollow at the base of the lamp may be filled with plaster of paris, or any other like cement, for the purpose of giving strength to the lamp and protecting the conducting wires and their attachments. The pores of the cement may, if thought advisable, be filled in with a fusible cement.

If a carbon filament in a lamp breaks, the neck of the lamp can be again cut across, and a fresh filament attached and the lamp sealed up, and exhausted or filled with a protective atmosphere as before. It will, however, be convenient to insert a small tube for exhaustion in one of the portions of the lamp before it is opened, as it is more difficult to do it afterwards.

I sometimes form the metal tool used for forming the hollow projection, B, with only one prong, so as to form one hollow pointed projection into the neck, and then seal in both the conducting wires near together, but not touching. I also use a metal tool with more than two prongs if I wish to have two or more filaments together in the same lamp. I also, in some cases, make the ends of the prongs chisel-shaped instead of pointed, more especially if one prong only is used.

One of the chief difficulties in the construction of such lamps is the sealing in of the wires. It is difficult to make a good junction between the glass and the metal, except in the case of platinum; and with thin conducting wires of platinum the low conductivity of the metal causes it to heat when large currents are used, and to crack the glass or cause a leak at the junction. I get over this difficulty by using a compound wire, having a core of copper, silver, gold, or other good conductor, and a platinum sheathing, so that I have the advantage either of using a cheaper metallic conductor or a metallic conductor of better conductivity, without any increased difficulty in making it form a good junction with the glass. The wire, whether compound or simple, may be used of a circular section, or in order still further to diminish the liability to crack, owing to unequal expansion, it may be flattened out into a ribbon or curved, so that it is of a horseshoe form in cross section.

For practical purposes it is of the greatest importance that lamps of this class, on the same circuit, should all have the same resistance when in use. To accomplish this I proceed as follows:—I attach the ends of the carbon filament to two small hollow copper or platinum terminals, which are fixed on a small bar of arsenic glass or similar non-conductor, so as to keep them at a suitable distance to fit upon the extremity of the conducting wires. If the carbon filament is sufficiently flexible to stand the necessary amount of manipulation I dispense with the bar of arsenic glass. I then place the filament in an apparatus, consisting of a bell-shaped receiver, which is in connection with an air-pump, and capable of being exhausted by it. The plate upon which this receiver rests is of ebonite, or similar non-conducting substance, and is fitted with pairs of pointed wires in metallic connection with binding screws, or terminals, on the outside of the apparatus. The pointed wires of each pair are at the same distance from each other as the copper or platinum terminals of the carbon filaments, so that a carbon filament, provided with the tubes above mentioned, can be placed with its terminals on one of the pairs of the pointed wires; and the copper or platinum tubes, being slipped over the ends of the wires, a current is sent through it from the outside while the exhaustion is going on.

It is, of course, not necessary that pointed wires should be used within the apparatus, as any other form of pairs of terminals, situated at the right distance from one another, will serve equally well; but if the ends of the carbon filament are encased in metallic tubes, in the manner described, it will be found most convenient to use these pointed wires. A convenient variation of the method is by suspending the portion of the lamp, marked B, in figure 6, by the conducting wires from pairs of terminals, the terminals in this case being fixed in a plate forming the top of the receiver instead of the bottom.

The carbon filaments are placed in this apparatus, the appearance of which, with the several carbon filaments, will be as shown in figure 8. The air is then exhausted, and a current is passed through each filament, and its resistance is measured when it is as nearly as possible under the same circumstances as in finished lamps. If the resistance of any of the filaments is found to be too high, the current is maintained through them while some hydro-carbon vapour, or chlorinated hydro-carbon vapour, or some other analogous compound, is admitted into the receiver by putting it into connection by means of a stop-cock, with a vessel containing the hydro-carbon or the chloroform. Instead of chloroform some hydro-carbon, either liquid or solid, of high boiling or volatilising point, and low vapour tension at ordinary temperatures, may be used, such, for example, as xylol or naphthaline. This causes a deposition of carbon on the highly heated filament; and so soon as the resistance of any filament is reduced to the standard amount the current is turned off from it, and the deposition ceases. A large number of carbon filaments can be operated on at one time by this method.

In figure 8, A is a glass vessel; B, a collar cemented into top of this vessel; C, a thick plate, preferably of vulcanised fibre, fitting into B, with a conically ground joint; DD', glass covered wires passing through C ground conically, and cemented into place; E, mercury poured over top to prevent access of air; F, lamp ends with filaments connected to them in electrical contact with DD'; G, tube leading to exhaust pump; H, tube leading to vessel containing chloroform or other substance. The tubes G and H should preferably both be fitted with laps. The chloroform or hydro-carbon might be placed in a cup, I.

The operation of regulating the resistance may be performed after the filament is attached to the lamp and the lamp attached to the pump. If the lamp is blackened in the operation it can be cut open, cleaned, re-sealed, and re-exhausted.

In making the vacuum in the vessel containing the carbon filament of an incandescent lamp, great difficulty is experienced in getting rid of the residual gas. This gas may be ordinary atmospheric oxygen or nitrogen, or it may be carbonic oxide or carbonic acid, derived from the combustion of portions of the carbon, or it may be aqueous vapour, or any other gas occluded by the carbon filament, or the metal conductors within the glass. When the exhaustion is carried to a high degree it is extremely difficult to predict

*Improvements in Electric Lamps.*

predict what will be the nature of this residual gas. The bulk of the occluded gas is got rid of by the ordinary process of heating the filament electrically during the progress of the exhaustion, but this method is not capable of removing the minute traces of residual gas, above referred to.

To accomplish this I enclose in the bulb of the lamp, or in a chamber forming part of the lamp, and connected with the bulb, a small quantity of some substance, having a more or less general power of absorption of gases. Thorina, heated to a degree below redness, possesses this property in a remarkable degree, and alumina, and many other earths have a similar property. If the substance used has a marked preference for some one gas, as some forms of alumina have for aqueous vapour. I expose the substance to be used to this gas before using it, so that it may be charged with it when first put into the lamp.

After introducing the absorbing substance into the lamp, I exhaust the bulb in the ordinary way and with the usual expedients for expelling the occluded gas from the carbon filament. When the exhaustion is tolerably complete, say to the one ten-thousandth part of an atmosphere. The absorbing substance is heated by applying the flame of a spirit lamp or other source of heat to the part of the glass where it is situated, and the gas occluded in it is driven off. The bulb is then re-exhausted as completely as possible, the heat being continued during the re-exhaustion. The bulb is then sealed off and the absorbing substance on cooling absorbs the residual gas in the bulb. By this means the exhaustion can be easily pushed to a degree that would be impracticable by the use of a pump only.

Instead of putting the absorbent material into the bulb of the lamp itself, it may be contained in a vessel permanently attached to the pump, so as to be in connection with the bulb of the lamp during the process of exhaustion.

By the above process it will generally be found easy to produce a very perfect vacuum such that it will not permit an induction current to pass which will strike across eight or ten centimetres of air. But the process may be varied by admitting into the lamp, after the first exhaustion has been effected (either with or without the aid of the process above described), some gas for which the absorbing substance has great absorbing power, and then heating and re-exhausting as before. In this way many absorbing substances which have not the power of general absorption to any great degree, but have a marked affinity for some special gas or vapour, such as charcoal, spongy palladium, or phosphoric anhydride may be used with very satisfactory results.

It is not necessary that the bulb should contain a very complete vacuum, provided that the residual gas or vapour therein is of such a character as to be incapable of acting chemically upon the carbon at any of the temperatures to which it is raised, and that the rarefaction is high enough, and the residual gas rare enough to make the scouring action of the intensely vibrating molecules of gas on the hot carbon imperceptible. I fill the bulb sometimes with mercury vapour, at such a density as would exist in a closed vessel containing mercury at ordinary temperatures. This may be done by leaving the lamp bulb in connection with the mercury pump for sufficient time after the exhaustion is finished to permit the diffusion of the mercury vapour. Another method is to place a gramme or two of mercury in the bottom of the lamp-bulb when it is connected with the pump, and after exhausting in the ordinary manner to a high degree, to raise the temperature of the lamp-bulb to the boiling point of mercury, the action of the pump being continued all the time. In this manner the vapour of mercury fills the lamp-bulb, driving before it all the residual gas, which would otherwise have been left in the bulb. The heating and pumping should be continued until no liquid mercury remains in the bulb. Instead of putting the few grammes of mercury direct in the lamp-bulb, they may be contained in a supplementary bulb close to the lamp, the heating and subsequent operations being the same as just described.

Having now described in detail the various parts of my invention, I shall proceed to specify that which I claim to have invented,—

- First—The use of hydrofluoric acid with or without other acids in the manufacture of carbons for electric lamps, and more especially the carbon filaments of incandescent lamps by exposing cellulose to the action of the acid or acids, and then carbonising the same, substantially as herein described.
- Second—The use of hydrofluoric acid, with or without other acids, in the manufacture of the various forms of carbon discs, sticks, or rods employed in electric lamps, by exposing carbon after carbonisation to the action of the acid or acids, such carbon being in the shape of thin sheets, or filaments, or fine powder, substantially as herein described.
- Third—The use of free chlorine or hydrochloric acid gas in the manufacture of the various forms of carbons employed in electric lamps to purify the carbon, substantially as herein described.
- Fourth—The preparation of a superior kind of carbon for use in electric lamps and otherwise, especially for the filaments used in incandescent lamps, by carbonising cellulose that has been dissolved in or acted on by a solution of oxide of copper in ammonia, substantially as herein described.
- Fifth—The application of a solution of oxide of copper in ammonia to paper, thread, or other form of cellulose, and afterwards carbonising the same for the purpose of rendering the carbon produced therefrom closer in the texture, denser, and more elastic and homogeneous, substantially as herein described.
- Sixth—The preparation of carbon, either in a pure state, or containing copper, from cellulose dissolved in a solution of oxide of copper in ammonia, and subsequently reduced to a solid and structureless form, substantially as herein described.
- Seventh—The manufacture of filaments for use in incandescent lamps out of a film or skin, prepared from cellulose dissolved in a solution of oxide of copper in ammonia, and then reduced to a solid and structureless form, substantially as herein described.
- Eighth—The method of making a strong and electrically perfect junction between the ends of the filament in an incandescent lamp, and the conducting wires, by electro-plating with copper, nickel, platinum, or other suitable metal, substantially as herein described.
- Ninth—The method of making a strong and electrically perfect junction between the ends of the filament in an incandescent lamp, and the conducting wires, by painting the junction with a solution of cellulose in a solution of oxide of copper in ammonia and subsequent carbonisation, substantially as herein described.

*Improvements in Electric Lamps.*

- Tenth—The method of diminishing the resistance of carbon filaments for use in incandescent lamps by electrically heating them in an atmosphere of chloroform vapour, substantially as herein described.
- Eleventh—The method of diminishing the resistance of carbon filaments for use in incandescent lamps, by electrically heating them in a vessel exhausted of air, which is in connection with a vessel containing a solid or liquid hydrocarbon, whose boiling or volatilizing point is high, and whose vapour density at ordinary temperatures is low, substantially as herein described.
- Twelfth—The use of cored wires with an external platinum surface, for conducting wires at the points where they pass through the glass of the bulbs of incandescent lamps, substantially as herein described.
- Thirteenth—The method of forming the glass enclosures for the filaments of incandescent lamps, herein described.
- Fourteenth—The introduction into the bulbs of incandescent electric lamps, or into chambers in connection therewith, and forming part of the lamps, of substances having a general power of absorbing gases for the purpose of getting rid of the residual gas after the exhaustion by the pump is completed, substantially as herein described.
- Fifteenth—The method of obtaining a good exhaustion by the introduction into the bulbs of incandescent electric lamps, or into chambers connected therewith, forming part of the lamps, of substances having a selective power of absorbing gases, whilst ensuring by the means herein above described or equivalent means, that the residual gas after the exhaustion by the pump is completed, is of a nature to be readily absorbed by such substances, substantially as herein described.
- Sixteenth—The methods of getting rid of the residual gas hereinabove described by the use of substances having a general or selective power of absorbing gases; the absorbing substances being placed in a chamber permanently connected with the pump used for exhausting the bulbs, and not in the bulbs themselves, or in chambers connected therewith, forming part of the lamps, and thus getting rid of the residual gas before sealing off the bulb of the lamp, substantially as herein described.
- Seventeenth—The introduction of mercury vapour in a highly rarefied state into the bulbs of incandescent lamps as a protective atmosphere, substantially as herein described.
- In witness whereof, I, the said William Crookes, have hereunto set my hand and seal, this twenty-seventh day of September, one thousand eight hundred and eighty-two.

WILLIAM CROOKES.

This is the specification marked "A," referred to in the annexed Letters of Registration granted to William Crookes, this nineteenth day of January, A.D. 1883.

AUGUSTUS LOFTUS.

## REPORT.

Sir,

Sydney, 12 December, 1882.

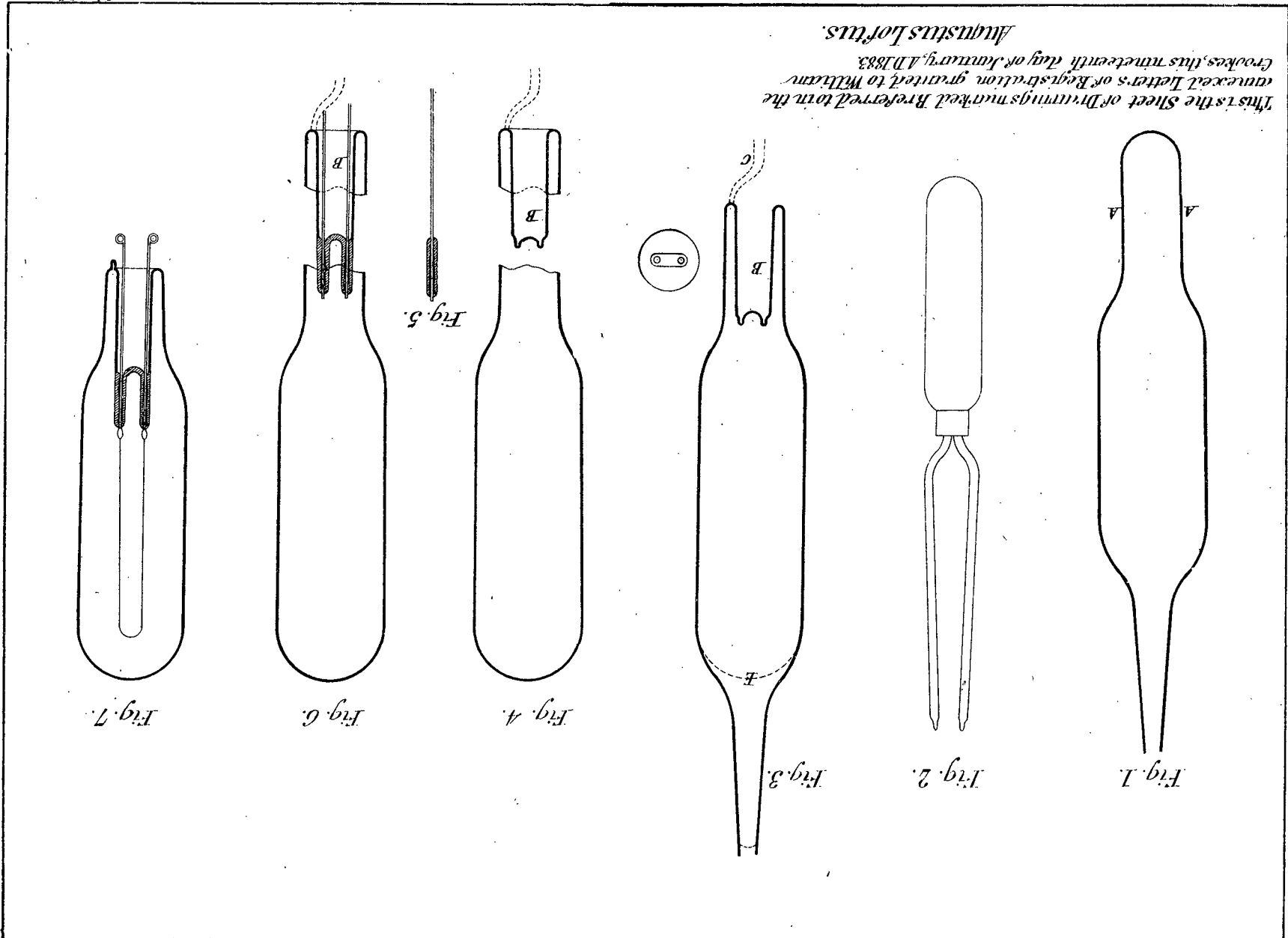
We do ourselves the honor to report, in reply to your blank cover communication of the 4th instant, No. 13,552, that we are of opinion Letters of Registration may be granted in favour of Mr. William Crookes, for an invention entitled "Improvements in the construction and manufacture of Electric Lamps," in terms of petition, specification, drawings, and claim.

We have, &amp;c.,

E. C. CRACKNELL.  
GOTHER K. MANN.

The Under Secretary of Justice.

[Drawings—two sheets.]

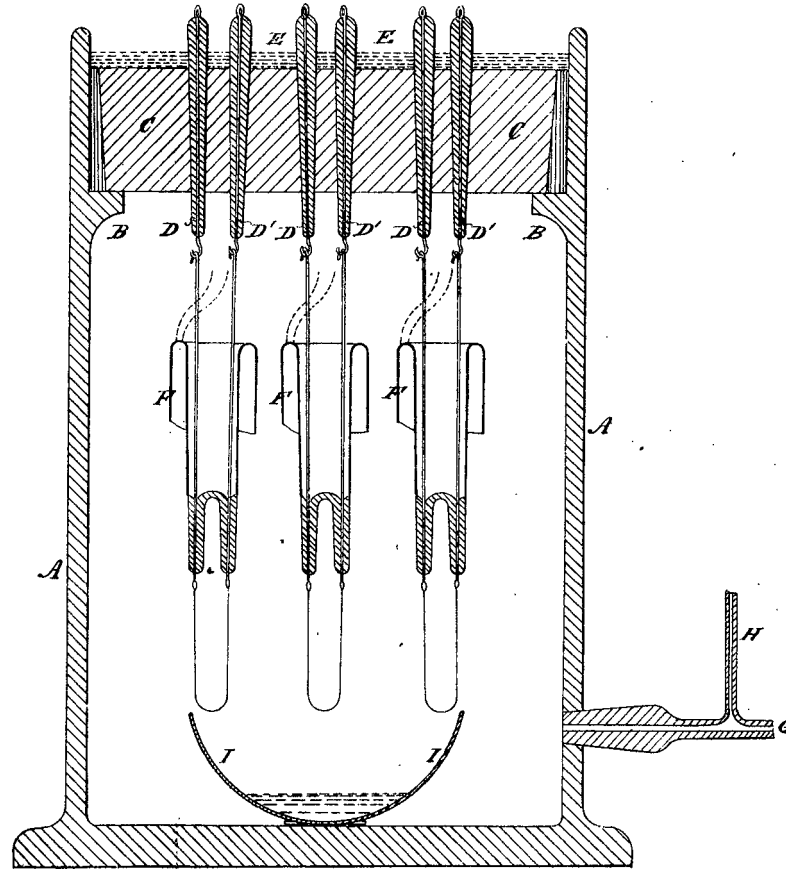


This is the Sheet of Drawings marked B referred to in the annexed Letters of Registration granted to William Crookes, this nineteenth day of January, A.D. 1883.

Augustus Lof'tus.



Fig. 8.



*This is the Sheet of Drawings marked C. referred to in the  
 annexed Letters of Registration granted to William Crookes,  
 this nineteenth day of January A. D. 1883.*

*Augustus Loftus.*



A.D. 1883, 19th January. No. 1180.

IMPROVEMENTS IN HARROWS.

LETTERS OF REGISTRATION to James Howard, Edward Tenney Bonsfield, and Henry William Gibbs, for Improvements in Harrows.

[Registered on the 19th day of January, 1883, in pursuance of the Act 16 Vic. No. 24.]

By HIS EXCELLENCY THE RIGHT HONORABLE SIR AUGUSTUS WILLIAM FREDERICK SPENCER LOFTUS (commonly called LORD AUGUSTUS LOFTUS), Knight Grand Cross of the Most Honorable Order of the Bath, a Member of Her Majesty's Most Honorable Privy Council, Governor and Commander-in-Chief of the Colony of New South Wales and its Dependencies.

TO ALL TO WHOM THESE PRESENTS SHALL COME, greeting :

WHEREAS JAMES HOWARD, EDWARD TENNEY BONSFIELD, and HENRY WILLIAM GIBBS, all of Bedford, England, have by their Petition humbly represented to me that they are the authors or designers of a certain invention or improvement in manufactures, that is to say, of an invention entitled "Improvements in Harrows," which is more particularly described in the specification marked A, and the four sheets of drawings marked B, C, D, and E respectively, which are herewith annexed; and that they, the said Petitioners, have deposited with the Honorable the Treasurer of the said Colony of New South Wales the sum of Twenty Pounds sterling, for defraying the expense of granting these Letters of Registration, as required by the Act of Council, sixteenth Victoria, number twenty-four; and have humbly prayed that I would be pleased to grant Letters of Registration, whereby the exclusive enjoyment and advantage of the said invention or improvement might be secured to them for a period of fourteen years: And I, being willing to give encouragement to all inventions and improvements in the arts or manufactures which may be for the public good, and having received a report favourable to the prayer of the said Petition, from competent persons appointed by me to examine and consider the matters stated therein and to report thereon for my information, am pleased, with the advice of the Executive Council, and in exercise of the power and authority given to me by the said Act of Council, to grant, and do by these Letters of Registration grant unto the said James Howard, Edward Tenney Bonsfield, and Henry William Gibbs, their executors, administrators, and assigns, the exclusive enjoyment and advantage of the said invention or improvement, for and during the term of fourteen years from the date hereof; to have, hold, and exercise unto the said James Howard, Edward Tenney Bonsfield, and Henry William Gibbs, their executors, administrators, and assigns, the exclusive enjoyment and advantage thereof, for and during and unto the full end and term of fourteen years from the date of these presents next and immediately ensuing, and fully to be complete and ended: Provided always, that if the said James Howard, Edward Tenney Bonsfield, and Henry William Gibbs shall not, within three days after the granting of these Letters of Registration, register the same in the proper office in the Supreme Court, at Sydney, in the said Colony of New South Wales, then these Letters of Registration, and all advantages whatsoever hereby granted, shall cease and become void.

In witness whereof, I have hereunto set my sign manual, and have caused the present Letters of Registration to be sealed with the seal of the said Colony of New South Wales, at Government House, Sydney, in New South Wales, this nineteenth day of January, in the year of our Lord one thousand eight hundred and eighty-three.

[L.S.]

AUGUSTUS LOFTUS.

*Improvements in Harrows.*

SPECIFICATION of JAMES HOWARD, EDWARD TENNEY BONSFIELD, and HENRY WILLIAM GIBBS, all of Bedford, England, for an invention entitled "Improvements in Harrows."

OUR invention relates to harrows, and comprises a novel construction of the frames, and manner of fastening the tines or teeth thereto.

Our improved harrows are constructed with longitudinal bars, which may be either straight, zig-zag, or curved. These longitudinal bars are made of iron or steel, and, by preference, of a double-channelled or H section, as the projecting ribs of such bars, in addition to giving greater strength and rigidity to the frame, offer facilities for the secure fastening of the teeth; but other sections of rib-bars or plain rectangular bars may be used in the construction of our harrows if desired.

One important feature of our said invention is that the tines of our improved harrows are held in position in a novel and effectual manner, by peculiarly formed clips or blocks interposed between the tines and the longitudinal bars. Each of the said blocks is grooved and shaped on one side to clip and bed itself on the channelled bar, and recessed on the other side to receive the head of the tine. Ordinarily the tine-head as well as the tine-block is perforated to receive a transverse bolt, which passes through the longitudinal bars, the tine-blocks, and hollow cross-pieces, as hereinafter described.

The tine blocks may be so formed as to permit the tines to assume different angles, by being reversed or otherwise adjusted.

Our invention is illustrated in the accompanying drawings in which—

Figure 1 is a plan or top view of a harrow constructed according to the said invention.

Figure 2 is a transverse section of the same on the line *xx*, figure 1.

Figures 3, 4, and 5 are plans illustrating various modifications in the construction of the said harrows.

Figures 6, 7, and 8 are transverse sections on the lines  $7^1$ ,  $7^2$ ,  $7^3$ , figures 3, 4, and 5 respectively.

The remaining figures illustrate details and modifications of our invention, drawn to an enlarged scale.

Like letters indicate the same parts throughout the drawings. *aa* are the longitudinal bars, *bb* are the transverse or cross-bars or pieces, *cc* are the tines or teeth, *dd* are the tine-blocks or clips.

One manner of embodying our improvements in the construction of a harrow is illustrated in figures 9, 10, 11, and 12, figure 9 being a plan, figure 10 a front sectional elevation, and figure 11 a side elevation of a portion of one of our said harrows, and figure 12 a plan of the tine-block detached. In this instance the transverse or cross-bars or pieces *b* are hollow or channelled with a bolt  $b^1$ , extending through them, and through the longitudinal bars *a*, the tines *c*, and the tine-blocks or clips *d*, the said bolt being secured by a nut or nuts *e*, or by other suitable means. The hollow cross-bars *b* may be of any suitable form in cross section. We make them preferably as shown in figures 9, 10, 11, and 11<sup>a</sup>, the ends of the cross-bar being notched and fitted between the ribs of the longitudinal bars.

A convenient manner of providing for the adjustment of the tines to different angles according to our invention is shown in figure 20, which is a side view of a portion of a harrow. The tine *c* is perforated, and the bolt  $b^1$  extends through the same, the longitudinal bars *a* and the block *d* as above described. The said block has its recess which receives the head of the tine widened obliquely as shown, so that the said tine may occupy a perpendicular position, as shown in full lines, or may be set to an angle corresponding with the oblique or inclined sides of the said recess, as shown in dotted lines. To allow for an intermediate position of the tines when required a suitable recess is formed in the opposite side of the tine-clip or block, and the said block is reversed, as shown in figure 19.

Figure 13 is a plan, and figure 14 an elevation partly in section, and figures 15 and 16 are similar views, illustrating modifications of our invention; that is to say, these views show arrangements wherein the tines *c* are solid or unperforated and adjustable vertically, instead of being perforated to admit the transverse bolt as before described. In these arrangements we use modified forms of tine-blocks and transverse fastenings. The transverse bars or sketches *b*, as shown in figures 15 and 16, are solid, and have enlarged parts through which we punch or otherwise form holes or mortices. In this case the tines *c* are passed through the said holes or mortices in the said cross-bars and secured therein by the endwise pressure of the transverse bolts or screws, the tine being firmly gripped between the side  $d^1$  of the mortice in the tine-block, and the side  $b^3$  of the mortice or recess in the transverse bar *b*, as shown. In the arrangement shown in figures 13 and 14 the mortice is formed partly in the block *d*, and partly in the lateral projection or lug  $b^2$  of the tubular cross-bar *b*, the tine being secured in its place thereon by the endwise pressure which causes these parts to impinge forcibly on the said tine as above described.

We sometimes use solid cross-bars in combination with the perforated tines, as shown in figures 17 and 18, which are sectional, front, and side elevations. In this modification of our invention, the said transverse-bars or stretchers *b* are made of flat or round iron, and they have collars  $b^4$  formed thereon which bear against the tines. From these collars the said bars extend through the said tines *c*, the blocks *d*, and the longitudinal bars *a*, outside of which they are secured by nuts *e* as shown.

Although, as above stated, we consider the employment of the blocks or clips in combination with the bars and tines to be a very advantageous feature of our invention, yet we may dispense with these blocks, and arrange the tines *b* to impinge or bed themselves upon or in recessed portions of the ribs of the longitudinal bars, as shown in figures 21 and 22, their security being obtained by the endwise pressure which ensures the tines being tightly gripped and held between the said bars and the projecting lugs of the hollow cross-bars as above described.

The harrow shown in figures 1 and 2 has its tines constructed and secured in place in the manner particularly described with reference to figures 9, 10, 11. It will be seen that in this case some of the transverse bolts  $b^1$  which pass through the tubular bars *b*, extend throughout the entire width of the harrow. In figures 3 and 6 we have shown a pair of longitudinal bars *a* united by cross-bars *b* and bolts  $b^1$ , the said cross-bars, the construction of the tines *c*, and the tine-blocks *d*, and manner of uniting and securing the same, being such as described with reference to figures 13 and 14. In figures 4 and 7, which show another pair of longitudinal bars *a* united by cross-bars or stretchers *b*, we employ the construction and arrangement particularly described with reference to figures 15 and 16. And in figures 5 and 8 we have shown the pair of longitudinal bars *a* in combination with the modified form of cross-bars *b* and other parts, as particularly described with reference to figures 17 and 18.

Having

*Improvements in Harrows.*

Having thus fully described our invention, and shown how the same may be conveniently and advantageously carried into practice, we wish it understood that we claim the improvements in harrows comprising—

First—The combination with the longitudinal and transverse bars and the tine of a clip or block recessed or grooved on one side to fit the longitudinal bar, and on the other side to receive and hold the said tine, and placed between the said longitudinal bar and the tine, the said tine and block and bars being united and secured by a bolt passing through them, and made tight by nuts or other means, all substantially as set forth.

Second—The modification of our invention, wherein the tine is secured in the morticed cross-bar by the aid of the recessed clip or block placed between the said tine and the longitudinal bar, and the nuts or other fastenings substantially as set forth and shown in figures 15 and 16 of the drawings.

Third—The modification of our invention, wherein the tine is secured between the clip or block and the projection or lug on the side of the tubular cross-bar, substantially as set forth and shown in figures 13 and 14 of the drawings.

Fourth—The modification of our invention, wherein we dispense with the said clips or blocks and secure the tines by endwise pressure, so that the said tine is gripped between the longitudinal bar and the projection or lug on the side of the tubular cross-bar, substantially as set forth and shown in figures 21 and 22 of the drawings.

Fifth—The means for permitting the adjustment of the tines to any desired angle, substantially as set forth.

Sixth—A harrow constructed of any suitable number of longitudinal and transverse bars, and having the tines secured thereby or therein by the aid of the aforesaid clips or blocks, or otherwise in accordance with either of the forms or modifications of our invention as above set forth.

In witness whereof, we, the said James Howard, Edward Tenney Bonsfield, and Henry William Gibbs, have hereto set our hands and seals, this 22nd day of September, 1882.

Witness—

ROWLAND GEORGE BROWN.

JAMES HOWARD.  
EDWARD TENNEY BONSFIELD.  
HENRY WILLIAM GIBBS.

This is the specification marked A referred to in the annexed Letters of Registration granted to James Howard, Edward Tenney Bonsfield, and Henry William Gibbs, this nineteenth day of January, A.D. 1883.

AUGUSTUS LOFTUS.

---

REPORT.

---

Sir,

In accordance with your letter of the 22nd November, we have examined the specification and plans attached to the application of James Howard, Edward Tenney Bonsfield, and Henry William Gibbs for protection for an invention, "Improvements in Harrows," and have to report that we see no reason why the protection sought should not be granted.

The Under Secretary of Justice.

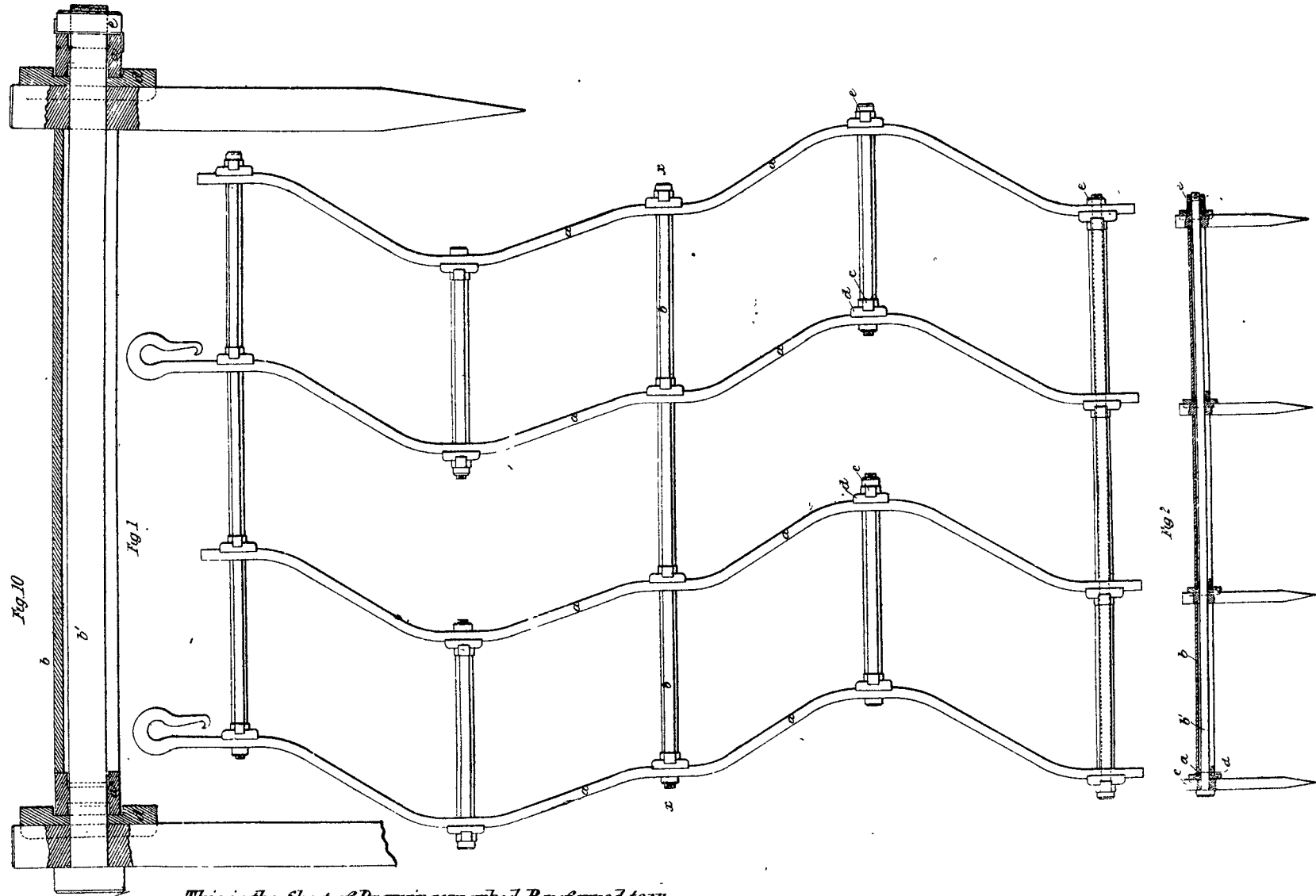
Sydney, 14 December, 1882.

We have, &c.,

JAMES BARNET.  
WILLIAM C. BENNETT.

---

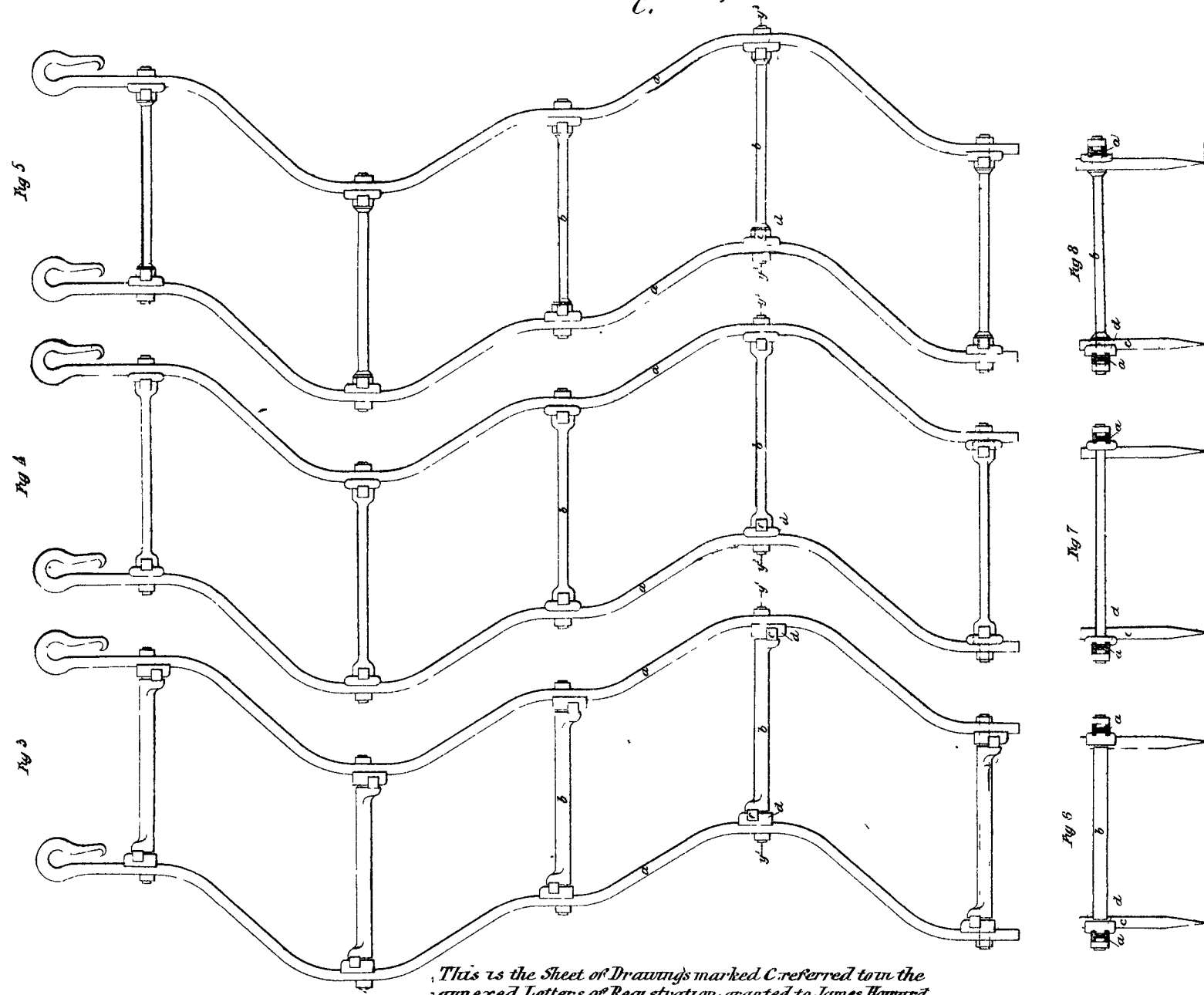
Drawings—four sheets.]



*This is the Sheet of Drawings marked B. referred to in the annexed Letters of Registration granted to James Howard, Edward Tenney Bousfield, and Henry William Gibbs, this nineteenth day of January, A. D. 1883.*

*Augustus Loftus.*

C.



*This is the Sheet of Drawings marked C. referred to in the annexed Letters of Registration, granted to James Howard, Edward Tenney Bousfield and Henry William G. Gbs, this nineteenth day of January A.D 1883.*

*Augustus Loftus.*

*Fig 35*

D.

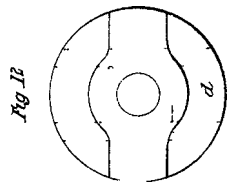
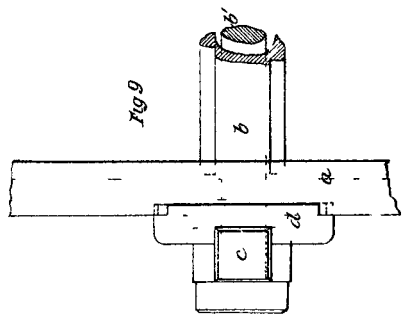
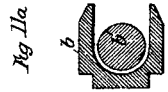
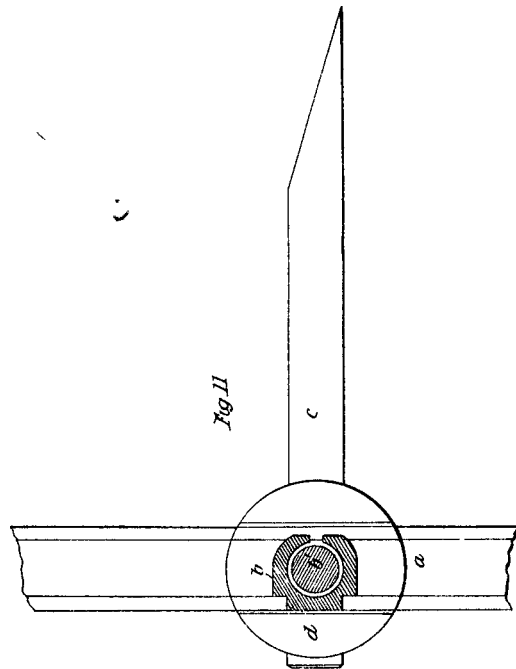
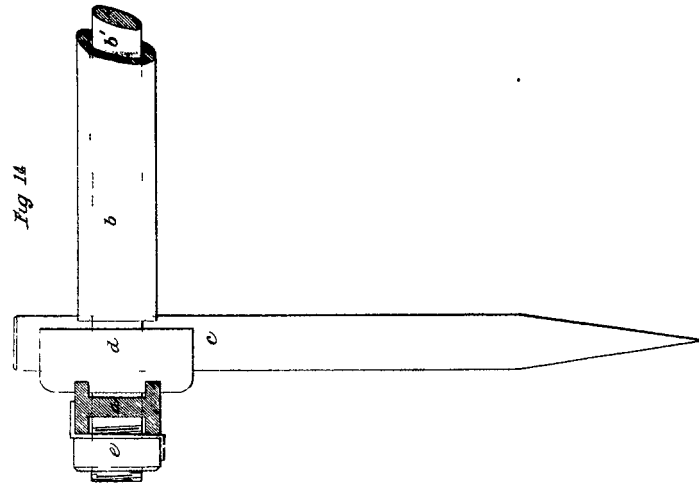
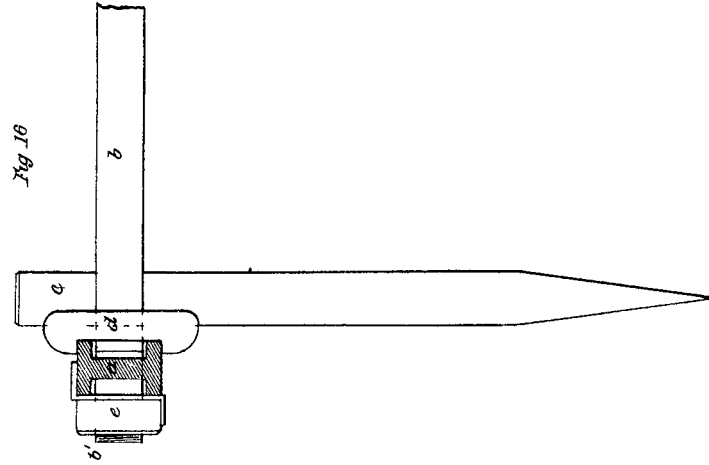
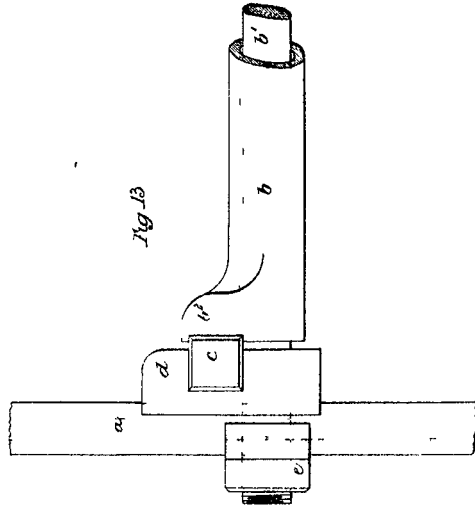
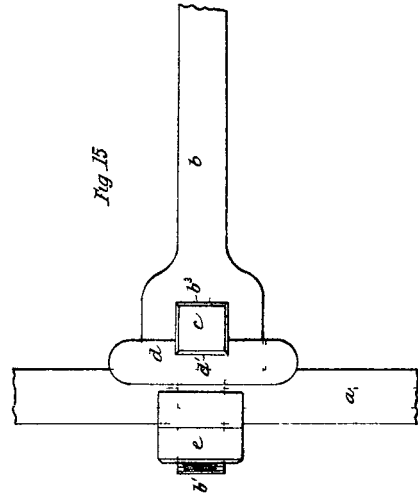
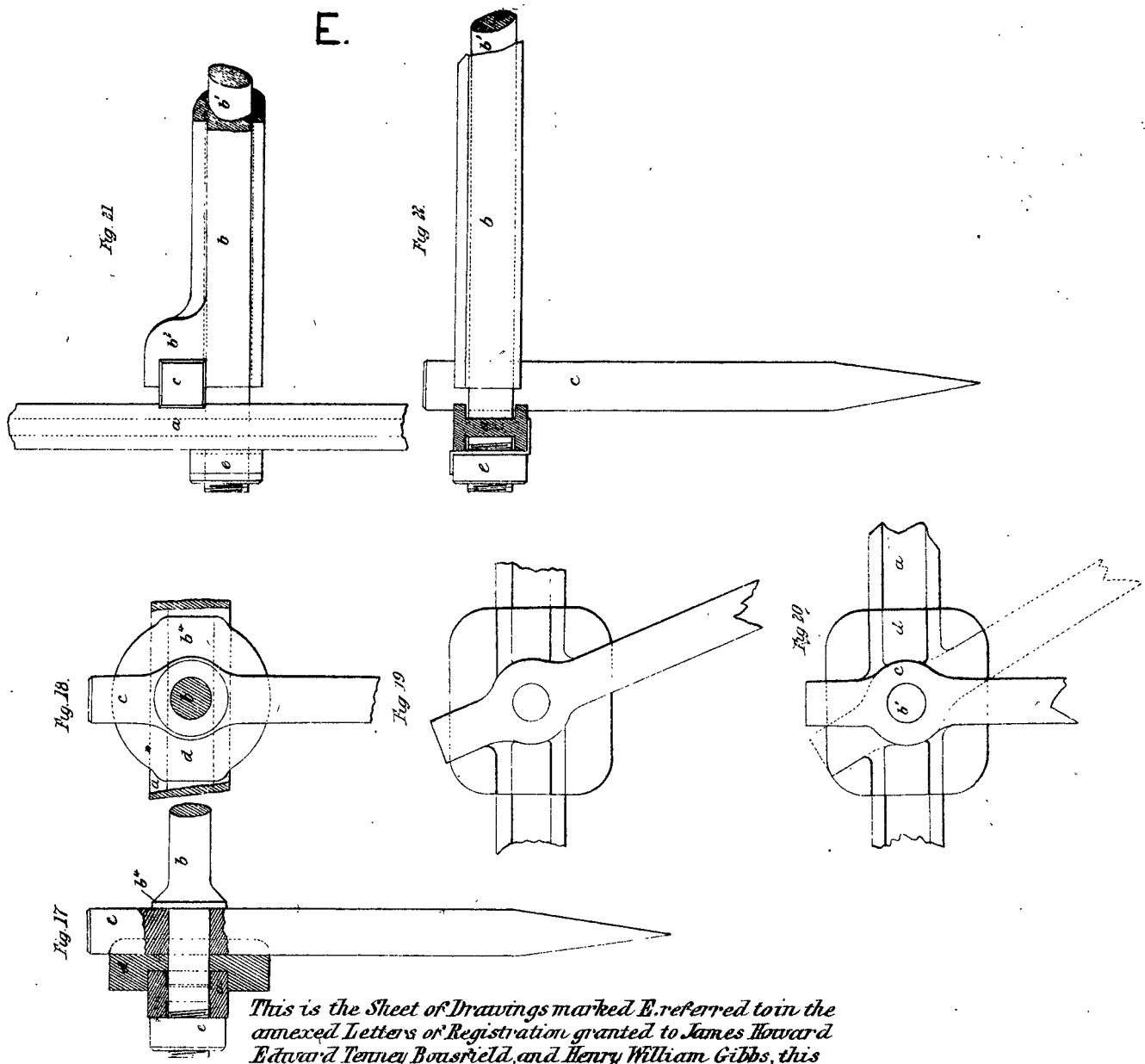


Fig. 3a



*This is the Sheet of Drawings marked D referred to in the annexed Letters of Registration granted to James Howard Edward Tenney Bousfield and Henry William Gibbs, this nineteenth day of January, A. D. 1883.*

*Augustus Loftus.*



*This is the Sheet of Drawings marked B. referred to in the annexed Letters of Registration granted to James Howard Edward Tenney Bousfield, and Henry William Gibbs, this nineteenth day of January A.D. 1883.*

*Augustus Loftus*






---

A.D. 1883, 19th *January*. No. 1181.

---

**A PERPENDICULAR GAS-GENERATING BURNER.**

**LETTERS OF REGISTRATION** granted to William Hooker, for an invention entitled "A Perpendicular Gas-generating Burner for portable Lamps, constructed to contain a Reservoir of illuminating fluid."

[Registered on the 19th day of January, 1883, in pursuance of the Act 16 Vic. No. 24.]

---

BY HIS EXCELLENCY THE RIGHT HONORABLE SIR AUGUSTUS WILLIAM FREDERICK SPENCER LOFTUS, (commonly called LORD AUGUSTUS LOFTUS), Knight Grand Cross of the Most Honorable Order of the Bath, a Member of Her Majesty's Most Honorable Privy Council, Governor and Commander-in-Chief of the Colony of New South Wales and its Dependencies.

TO ALL TO WHOM THESE PRESENTS SHALL COME, greeting :

WHEREAS WILLIAM HOOKER, of Lyndhurst-street, Glebe, Sydney, in the Colony of New South Wales, gas-engineer, hath by his Petition humbly represented to me that he is the author or designer of a certain invention or improvement in manufactures, that is to say, of an invention entitled "A Perpendicular Gas-generating Burner for Portable Lamps, constructed to contain a reservoir of illuminating fluid," which is more particularly described in the specification and the sheet of drawings which are hereunto annexed ; and that he, the said Petitioner, hath deposited with the Honorable the Treasurer of the said Colony of New South Wales the sum of Twenty Pounds sterling, for defraying the expense of granting these Letters of Registration, as required by the Act of Council, sixteenth Victoria, number twenty-four, and hath humbly prayed that I would be pleased to grant Letters of Registration, whereby the exclusive enjoyment and advantage of the said invention or improvement might be secured to him for a period of fourteen years : And I, being willing to give encouragement to all inventions and improvements in the arts or manufactures which may be for the public good, and having received a report favourable to the prayer of the said Petition, from competent persons appointed by me to examine and consider the matters stated therein and to report thereon for my information, am pleased, with the advice of the Executive Council, and in exercise of the power and authority given to me by the said Act of Council, to grant, and do by these Letters of Registration grant unto the said William Hooker, his executors, administrators, and assigns, the exclusive enjoyment and advantage of the said invention or improvement for and during the term of fourteen years from the date hereof ; to have, hold, and exercise unto the said William Hooker, his executors, administrators, and assigns, the exclusive enjoyment and advantage thereof, for and during and unto the full end and term of fourteen years from the date of these presents next and immediately ensuing, and fully to be complete and ended : Provided always, that if the said William Hooker shall not, within three days after the granting of these Letters of Registration, register the same in the proper office in the Supreme Court, at Sydney, in the said Colony of New South Wales, then these Letters of Registration, and all advantages whatsoever hereby granted, shall cease and become void.

In witness whereof, I have hereunto set my sign manual, and have caused the present Letters of Registration to be sealed with the seal of the said Colony of New South Wales, at Government House, Sydney, in New South Wales, this nineteenth day of January, in the year of our Lord one thousand eight hundred and eighty-three.

[L.s.]

AUGUSTUS LOFTUS.

*A Perpendicular Gas-generating Burner.*

SPECIFICATION by WILLIAM HOOKER, of Lyndhurst-street, Glebe, Sydney, in the Colony of New South Wales, gas-engineer, of the invention of a Perpendicular Gas-generating Burner for portable Lamps (constructed to contain a reservoir of illuminating fluid).

I, THE above-named William Hooker, do hereby declare the nature of my said invention for a perpendicular gas-generating burner for portable lamps (constructed to contain a reservoir of illuminating fluid), the particulars thereof, and in what manner the same is to be performed, to be particularly described and ascertained in and by the following statement, reference being made to the sheet of drawings hereunto annexed, that is to say:—

The said invention has for its object the means of generating gas from a gaseous oil or illuminating fluid by a perpendicular gas-generating burner, being in construction a perpendicular complex gas-generating tube terminating in a gas-burner fixed into a portable table-lamp, or hand-lamp, or lamp for a bracket or chandelier, constructed to contain a globe or reservoir for illuminating fluid, the tube or burner referred to converting the lamp into a self-acting gas-generating portable lamp.

The invention consists in the complex tube terminating in a gas-burner shown in figure No. 2, of which the construction is as follows:—

A is a small brass inner tube, fully shown in figure 1. It is perforated with small holes for about 2 inches from the top, for the purpose of arresting the progress of the outer tube, as presently shown, of the illuminating fluid. It is filled at the lower part, where shown between *ff* with wick or any other porous packing which may be regarded more suitable. Around this tube, for its entire length, is covered a single layer of well-woven wick (but any other porous packing regarded more suitable may be substituted for the wick). The wick for 1 inch or  $1\frac{1}{2}$  inch from the top, and the top of the tube, is covered with asbestos, shown by the letters *ggg*, fixed on with fine copper wire.

B, as shown in figure 2, is an outer brass tube of sufficient size to admit tube.

A, with the before-mentioned packing around it, fitting therein.

C is another larger and shorter tube, of which the length is according to the depth of the reservoir K, shown in figure 3, into which tube B (containing tube A and the said packing) is fixed, and which is arranged for the reception of air, or of a heat non-conducting substance, if regarded advisable, to prevent the possibility of the fluid in reservoir K, shown in figure 3, from becoming heated. I believe, and at present find, the admission of air to suffice.

The tube C is closed at the bottom with solid metal for the space between the outer rim thereof and the outer rim of tube B, and the bottom of tubes A and B are closed with metal gauge.

D, marked in figure 2, is a small gas-reservoir and gas-burner combined, of larger circumference than tube B, which is screwed on the tube B, and may be varied in size so as to give a larger or lesser light. *ee* are perforated holes therein forming jets, at which the gas is burned, and which may be of different sizes, and vary in number.

H consists of a small chamber in the shape of an ornament, closed near the top, and communicating with tube C, containing perforated holes or figures as shown in the drawing, through which the air passes into tube C.

I is a small open cup formed in the upper part of the chamber H.

H, shown in figure 3, is the globe, or reservoir, of an ordinary table or portable lamp, which is filled with the illuminating fluid, and into which the complex tube, shown in figure 2, is fixed by means of a screw, as in the case of an ordinary table-lamp, and as shown in figure 3.

The lamp is used by first placing a few drops of spirit into the cup I. Upon the application of a match thereto the burning of the spirit (lasting for less than half a minute of time) will so far heat tube B, and the fluid with which it comes into contact, as to generate gas from the gaseous illuminating fluid which fills the chamber D, and escapes through the holes or jets, *ee*, and is at once converted into flame from the burning spirit beneath. When the gas is once lighted at the jets the heat thereby created will continue to generate gas from the illuminating fluid.

The advantages and improvements afforded by this invention are—

1. The generating of gas from a gaseous illuminating fluid by means of a perpendicular gas-generating tube inserted in the illuminating fluid without the necessity of a reservoir for the illuminating fluid being placed above the generating tube or burner, with a descending pipe to supply the illuminating fluid as used in other lamps for generating gas from an illuminating fluid now in use in this Colony.
2. The absence of any continuous jets or pilot lights as used in such other gas-generating lamps for the purpose of keeping the generating tube heated, in addition to the gas flame emitting light.
3. The prevention of the illuminating fluid overflowing or escaping in the form of liquid fire, through such pilot lights, as in such other gas-generating lamps, if the tap used to admit the fluid into the heated tube is opened too far, and too much of the fluid passes through.
4. The absence of any such tap, as in such other generating lamps, for the admission of fluid into the burner, at all times requiring careful manipulation.

I do not claim as part of my invention that portion of it which consists of the application of heat to a tube through which an illuminating fluid passes for the purpose of generating gas therefrom.

But I do claim as my invention—

Generally—an improved construction of a portable gas-generating lamp (constructed to contain a reservoir of illuminating fluid) by means of the combination hereinbefore described.

And particularly—

- 1st. A perpendicular complex tube and burner, as hereinbefore described, for insertion in a reservoir of gaseous illuminating fluid as a means of extracting gas therefrom with increased facility and safety, and as a means of converting into a self-acting gas-generating lamp a lamp of the ordinary construction for oil or illuminating fluid to serve as a portable table-lamp, hand-lamp, or portable lamp for a bracket or chandelier.

---

*A Perpendicular Gas-generating Burner.*

---

- 2nd. A gas-generating tube or burner for such portable lamps, without the aid of a tap and other external apparatus or contrivance for admitting into it the illuminating fluid.
- 3rd. A gas-generating tube or burner, constructed as hereinbefore mentioned, for portable lamps, without the aid of continuous jets or pilot lights, as hereinbefore mentioned, in addition to the flame-emitting light.

In witness whereof, I, the said William Hooker, have hereunto set my hand, this twenty-third day of November, in the year of our Lord one thousand eight hundred and eighty-two.

WILLIAM HOOKER.

Signed by the said William Hooker in the presence of,—

ALFRED DE LISSA,  
Solicitor, Sydney.

This is the specification referred to in the annexed Letters of Registration granted to William Hooker, this nineteenth day of January, A.D. 1883.

AUGUSTUS LOFTUS.

---

**REPORT.**

---

Sir,

The application of Mr. Alfred De Lissa, for Letters of Registration for Mr. William Hooker, for an invention of a "Perpendicular Gas-generating Burner for Portable Lamp" having been referred to us, we have examined the plan and specification accompanying the same, and have now the honor to report that we see no objection to the issue of Letters of Registration as prayed for.

Sydney, 11 December, 1882.  
We have, &c.,  
JAMES BARNET.  
H. C. RUSSELL.

The Under Secretary of Justice.

[Drawings—one sheet.]

Fig. 3.

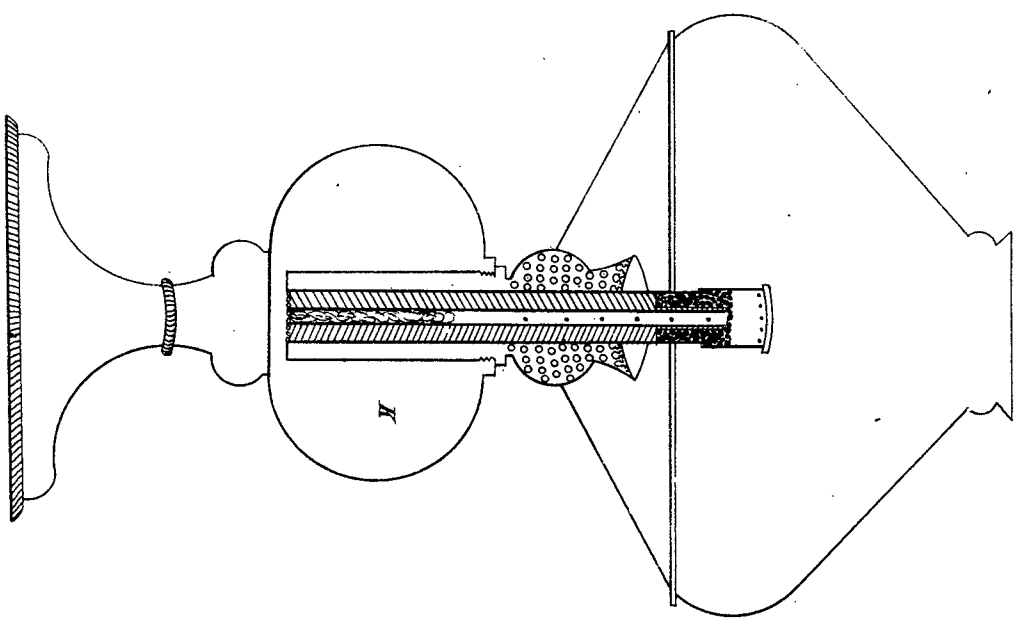


Fig. 2.

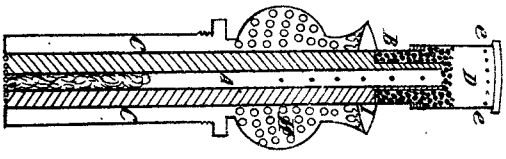
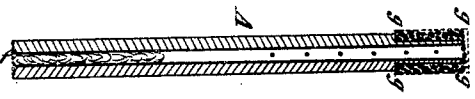


Fig. 1.



*This is the Sheet of Drawings referred to in the annexed  
 Letters of Request granted to William Hooper, this  
 nineteenth day of January A.D. 1883.*

*Augustus Lortus.*

*(Sig. 35-)*



A.D. 1883, 19th January. No. 1182.

**IMPROVEMENTS IN MACHINES FOR EXCAVATING AND REMOVING PLOUGHED OR SOFT EARTH.**

**LETTERS OF REGISTRATION** to Tasman Algar Phillips, for an invention entitled "Improvements in Machines for Excavating and Removing Ploughed or Soft Earth."

[Registered on the 19th day of January, 1883, in pursuance of the Act 16 Vic. No. 24.]

BY HIS EXCELLENCY THE RIGHT HONORABLE SIR AUGUSTUS WILLIAM FREDERICK SPENCER LOFTUS (commonly called LORD AUGUSTUS LOFTUS), Knight Grand Cross of the Most Honorable Order of the Bath, a Member of Her Majesty's Most Honorable Privy Council, Governor and Commander-in-Chief of the Colony of New South Wales and its Dependencies.

TO ALL TO WHOM THESE PRESENTS SHALL COME, greeting :

WHEREAS TASMAN ALGAR PHILLIPS, of Bourke, in the Colony of New South Wales, hath by his Petition humbly represented to me that he is the author or designer of a certain invention or improvement in manufactures, that is to say, of an invention entitled "Improvements in Machines for Excavating and Removing Ploughed or Soft Earth," which is more particularly described in the specification and the sheet of drawings which are hereunto annexed; and that he, the said Petitioner, hath deposited with the Honorable the Treasurer of the said Colony of New South Wales the sum of Twenty Pounds sterling for defraying the expense of granting these Letters of Registration, as required by the Act of Council sixteenth Victoria, number twenty-four; and hath humbly prayed that I would be pleased to grant Letters of Registration, whereby the exclusive enjoyment and advantage of the said invention or improvement might be secured to him for a period of fourteen years: And I, being willing to give encouragement to all inventions and improvements in the arts or manufactures which may be for the public good, and having received a report favourable to the prayer of the said Petition, from competent persons appointed by me to examine and consider the matters stated therein and to report thereon for my information, am pleased, with the advice of the Executive Council, and in exercise of the power and authority given to me by the said Act of Council, to grant, and do by these Letters of Registration grant unto the said Tasman Algar Phillips, his executors, administrators, and assigns, the exclusive enjoyment and advantage of the said invention or improvement, for and during the term of fourteen years from the date hereof; to have, hold, and exercise unto the said Tasman Algar Phillips, his executors, administrators, and assigns, the exclusive enjoyment and advantage thereof, for and during and unto the full end and term of fourteen years from the date of these presents next and immediately ensuing, and fully to be complete and ended: Provided always, that if the said Tasman Algar Phillips shall not, within three days after the granting of these Letters of Registration, register the same in the proper office in the Supreme Court, at Sydney, in the said Colony of New South Wales, then these Letters of Registration, and all advantages whatsoever hereby granted, shall cease and become void.

In witness whereof, I have hereunto set my sign manual, and have caused the present Letters of Registration to be sealed with the seal of the said Colony of New South Wales, at Government House, Sydney, in New South Wales, this nineteenth day of January, in the year of our Lord one thousand eight hundred and eighty-three.

AUGUSTUS LOFTUS.

*Improvements in Machines for Excavating and Removing Ploughed or Soft Earth.*

SPECIFICATION of TASMAN ALGAR PHILLIPS, of Bourke, in the Colony of New South Wales, for an invention entitled "Improvements in Machines for Excavating and Removing Ploughed or Soft Earth."

My improvements consist first in so constructing the excavating tool or implement that it will jump or rise over any obstacles which it cannot lift or pass through; secondly, in utilising the weight of the driver to keep the tool to its work, and to quickly return it to its working position after it has jumped or risen. They consist thirdly in a peculiar construction of the body or box for removing the earth, so that its bottom will tilt when loaded and raise the back, and when emptied the weight of the back return the bottom to its place. They further consist in the combination and arrangement with these novel parts of well known mechanical contrivances, so as to form a light, durable, and convenient machine for excavating, removing, and afterwards discharging ploughed or soft earth.

This improved machine is carried by two pairs of wheels, between the front pair of which is the excavating tool consisting of a spade or plate inclining forwards, and having at its point a roller or a fixed steel bar to suit light or heavy work, and it is pivoted to and drawn by the forecarriage under which the said wheels swivel on a king-bolt; said spade has two cheeks similarly pivoted to the forecarriage although independently of it. The hinder wheels support the box, and between the spade and this box is a set of elevators driven by a chain or chains from one or both the hinder wheels. The spade is lowered to and raised from its work by back chains worked by handwheels within reach of the driver, and a hook or hooks on the back of the spade raises the cheeks. A clutch automatically throws the elevators out of action when the spade is raised. The tilting bottom of the box is kept in position by catches, which may be released by the driver when required.

Referring to my drawings, figure 1 shows a side elevation of a machine constructed according to my invention, with the near side front wheel removed; figure 2 a front view, and figure 3 a plan of the same. A is the excavating tool or spade; A<sup>1</sup> is a small roller the whole width of the back at its lower end; A<sup>2</sup> its radial stays pivoted to cross-bar C<sup>1</sup>, having circle plate C<sup>2</sup> of reaches C; B are the cheeks, and B<sup>1</sup> their radial stays; A<sup>3</sup> is a hook, and B<sup>2</sup> a cross-stay; C<sup>3</sup> are standards, C<sup>4</sup> pulleys, and C<sup>5</sup> hand-wheels; C<sup>6</sup> ratchet wheel and pawl; A<sup>4</sup> chains; D are the front wheels, D<sup>1</sup> their axle; E is a spring seat on slotted rod, E<sup>1</sup> the bottom of which is joined by link E<sup>2</sup>, to cross-stay E<sup>3</sup>, between radial stays A<sup>3</sup>. FF are the elevator sides; F<sup>1</sup> and F<sup>2</sup>, top and bottom tumblers; F<sup>3</sup> hinged plates forming the chain, and F<sup>4</sup> the lifters. GG are the hind wheels; G<sup>1</sup> their axle, and G<sup>2</sup> groove therein; G<sup>3</sup> is chain; G<sup>4</sup> sprocket-wheel; H a clutch; H<sup>1</sup> its lever pivoted at H<sup>2</sup>, and passing through slotted angle piece; H<sup>3</sup> attached to cheek B; H<sup>4</sup> and H<sup>5</sup> are cogwheels. This gear I prefer to make identically the same on both sides, but only show it on the one to prevent confusion. The front I, sides I<sup>1</sup> and back stays I<sup>2</sup> of the box are fixtures; I<sup>3</sup> is the back; I<sup>4</sup> the tilting bottom; I<sup>5</sup> rod on which it tilts; I<sup>6</sup> a cord passing from the back at I<sup>1</sup> over pulley I<sup>3</sup> to the bottom at I<sup>5</sup>; J are catches on rod J<sup>1</sup>, having lever J<sup>2</sup> from which rod or cord J<sup>3</sup> reaches to seat E. I sometimes fix a set of spreaders constructed similarly to the elevators running horizontally the whole length of the box, and drive them off the spindle of cogwheels H<sup>5</sup>; shafts or a pole may be fixed to the fore axle as is well understood.

When at work, the various parts of the machine are in the positions shown in the drawing, and it is drawn over the ground, and the soil is thus forced up the inclined spade A, being kept thereon by cheeks B, and falls over the top upon lifters F<sup>4</sup>, which raise it and discharge it into the box or body; should the spade A strike or come into contact with any obstacle it cannot move, it rises up on the radial arms A<sup>3</sup> until past such obstacle, when the weight of the driver on the seat E forces it into its work again. When the box or body is sufficiently loaded, the driver turns either hand-wheel C<sup>5</sup>, thus raising spade A, and hook A<sup>3</sup> catching cross-bar B<sup>2</sup> lifts the cheeks B. The same motion by means of slotted angle piece H<sup>3</sup> throws the clutch H out of gear and stops the elevators. The machine is then driven to the place of discharge, when upon the driver pulling cord J<sup>3</sup>, the catches J are released, and the load tilts the bottom I<sup>4</sup> to the position shown by dotted lines, and at the same time raising the back I<sup>3</sup>. The advance of the machine now discharges its contents, and the back I<sup>3</sup> draws the bottom I<sup>4</sup> up into position again, the catches being pushed aside and dropping into their place. All these movements take place without in any way stopping the machine, which is then ready to be again refilled.

Having thus fully described my invention and the manner of performing same, I would have it understood that I do not confine myself to the precise form in which my invention is carried into effect so long as the nature thereof be retained; but what I believe to be new and original, and therefore claim as my improvements in machines for excavating and removing ploughed or soft earth, is—

First—So constructing them that the excavating tool or implement will rise or jump over any obstacle it cannot lift or pass through, substantially as herein described and explained.

Second—An excavating tool made in the form of a spade or plate inclining forwards between two cheeks, which spade is pivoted to and drawn by a forecarriage, and kept to its work by the weight of the driver, substantially as herein described and explained.

Third—Making the box or body so that its bottom will tilt and raise the back when loaded, and so that the back will return the bottom to its place again when empty.

Fourth—The combination and arrangement of parts substantially as described, forming a complete machine as herein set forth and explained, and as illustrated in my drawings.

In witness whereof, I, the said Tasman Algar Phillips, have hereto set my hand and seal, this twenty-first day of November, one thousand eight hundred and eighty-two.

Witness—

TASMAN ALGAR PHILLIPS,

By his Agent, FRED. WALSH.

This is the specification referred to in the annexed Letters of Registration granted to Tasman Algar Phillips, this nineteenth day of January, A.D. 1883.

AUGUSTUS LOFTUS.

REPORT.

---

*Improvements in Machines for Excavating and Removing Ploughed or Soft Earth.*

---

REPORT.  
-----

Sir,

We do ourselves the honor to report, in reply to your blank cover communication, 2nd November, No. 1,323, that we are of opinion Letters of Registration may be granted in favour of Mr. Tasman Algar Phillips, for "Improvements in Machines for Excavating and Removing Ploughed or Soft Earth," in terms of his specification, drawings, and claim.

Sydney, 30 November, 1882.

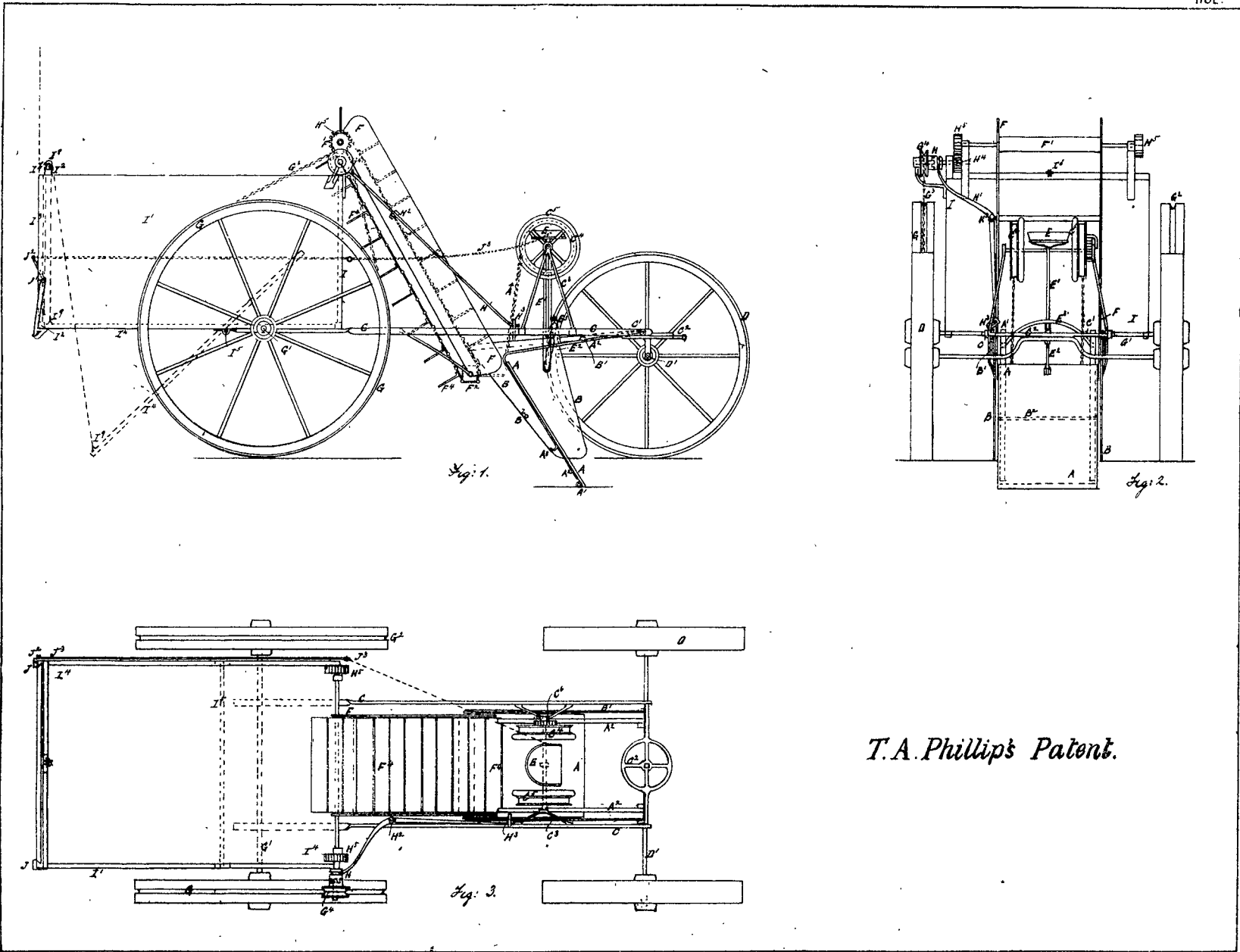
We have, &amp;c.,

EDMUND FOSBERY.  
GOTHER K. MANN.

The Under Secretary of Justice.

---

[Drawings—one sheet.]



T.A. Phillip's Patent.

This is the Sheet of Drawings referred to in the annexed letters of Registration granted to Tasmun Algar Phillip, this nineteenth day of January A.D. 1883.

Augustus Loftus.

PHOTO-LITHOGRAPHED AT THE GOVT. PRINTING OFFICE, SYDNEY, NEW SOUTH WALES.

Fig. 3b.





A.D. 1883, 19th January. No. 1183.

IMPROVEMENTS IN ELECTRIC SIGNALLING APPARATUS.

LETTERS OF REGISTRATION to Louis John Crossley, John Frederic Harrison, and Walter Emmott, for Improvements in Electric Signalling Apparatus.

[Registered on the 19th day of January, 1883, in pursuance of the Act 16 Vic. No. 24.]

BY HIS EXCELLENCY THE RIGHT HONORABLE SIR AUGUSTUS WILLIAM FREDERICK SPENCER LOFTUS (commonly called LORD AUGUSTUS LOFTUS), Knight Grand Cross of the Most Honorable Order of the Bath, a Member of Her Majesty's Most Honorable Privy-Council, Governor and Commander-in-Chief of the Colony of New South Wales and its Dependencies.

TO ALL TO WHOM THESE PRESENTS SHALL COME, greeting:

WHEREAS LOUIS JOHN CROSSLEY, of Halifax, in the County of York, JOHN FREDERIC HARRISON, of Bradford, in the County of York, and WALTER EMMOTT, of Halifax aforesaid, England, have by their Petition humbly represented to me that they are the authors or designers of a certain invention or improvement in manufactures, that is to say, of an invention entitled "Improvements in Electric Signalling Apparatus, applicable also to other purposes," which is more particularly described in the specification and the sheet of drawings which are hereunto annexed; and that they, the said Petitioners, have deposited with the Honorable the Treasurer of the said Colony of New South Wales the sum of Twenty Pounds sterling, for defraying the expense of granting these Letters of Registration, as required by the Act of Council, sixteenth Victoria, number twenty-four; and have humbly prayed that I would be pleased to grant Letters of Registration, whereby the exclusive enjoyment and advantage of the said invention or improvement might be secured to them for a period of fourteen years: And I, being willing to give encouragement to all inventions and improvements in the arts or manufactures which may be for the public good, and having received a report favourable to the prayer of the said Petition from competent persons appointed by me to examine and consider the matters stated therein and to report thereon for my information, am pleased, with the advice of the Executive Council, and in exercise of the power and authority given to me by the said Act of Council, to grant, and do by these Letters of Registration grant unto the said Louis John Crossley, John Frederic Harrison, and Walter Emmott, their executors, administrators, and assigns, the exclusive enjoyment and advantage of the said invention or improvement, for and during the term of fourteen years from the date hereof; to have, hold, and exercise unto the said Louis John Crossley, John Frederic Harrison, and Walter Emmott, their executors, administrators, and assigns, the exclusive enjoyment and advantage thereof, for and during and unto the full end and term of fourteen years from the date of these presents next and immediately ensuing, and fully to be complete and ended: Provided always, that if the said Louis John Crossley, John Frederic Harrison, and Walter Emmott shall not, within three days after the granting of these Letters of Registration, register the same in the proper office in the Supreme Court, at Sydney, in the said Colony of New South Wales, then these Letters of Registration, and all advantages whatsoever hereby granted, shall cease and become void.

In witness whereof, I have hereunto set my sign manual, and have caused the present Letters of Registration to be sealed with the seal of the said Colony of New South Wales, at Government House, Sydney, in New South Wales, this nineteenth day of January, in the year of our Lord one thousand eight hundred and eighty-three.

[L.s.]

AUGUSTUS LOFTUS.

*Improvements in Electric Signalling Apparatus.*

SPECIFICATION of LOUIS JOHN CROSSLEY, of Halifax, in the County of York, JOHN FREDERIC HARRISON, of Bradford, in the County of York, and WALTER EMMOTT, of Halifax aforesaid, England, for an invention entitled "Improvements in Electric Signalling Apparatus, applicable also to other purposes."

THIS invention relates to improvements in magneto-electric or electro-magnetic signalling apparatus for use in telephone exchanges, railway-signal, cabins, and for telegraphic and telephonic purposes generally, the improved signalling apparatus being also applicable to connecting and disconnecting wires used for telephonic, telegraphic, and other purposes.

For the purpose of illustration we will describe our invention as applied for use in telephone exchanges.

We take an ordinary magneto-electric call-bell apparatus, and to or in connection with the axis or spindle of the revolving coil or coils we adapt one or more cams, pins, or the like, so that it or they will make contact with a suitably placed spring or springs, or its or their equivalent, in such a manner that when the said coil or coils is or are rotated the electric currents are caused to flow out to the line in the direction or directions required by operating a key, or by other suitable means.

By this arrangement the subscribers to a telephone exchange, in addition to the ordinary call-signal, are enabled to transmit a distinct and separate signal to advise the exchange operator that the wires are free.

By the employment of relays, or other suitable electric apparatus, in the central office, such currents may be transmitted as will enable a subscriber, when it is convenient so to do, to disconnect his wire from the last subscriber with whom he spoke, and place both lines in connection with the switch-board, without the intervention of the operator.

In order to enable our invention to be better understood we will proceed to describe a suitable arrangement for carrying the same into effect, when used for telephone exchanges, by reference to the accompanying drawing, in which figure 1 represents a view of a coil such as is generally used in the magneto-calls or call-bell apparatus now in use; but any other suitable form of coil may be employed in carrying out our improvements. Figure 2 represents a sectional view of the metal body of the bobbin of the coil fitted with a spindle, cam, and springs, according to our improvements. Figure 3 represents a view showing a suitable arrangement for connecting an indicator with our improvements; and figure 4 represents an end view of the bobbin and cam shown in figure 2. Similar letters in all the figures represent similar parts.

In carrying out our improvements the ends of the wire of the coil A are connected respectively to the small pins P and P', figure 2; the pin P' is insulated from the metal body of the bobbin, and connected with the spindle S, which is also insulated from the bobbin. On the spindle S is fitted the cam C (or a pin, or its equivalent, may be employed); the cam C revolves with the coil, and at each revolution makes contact with the spring or springs J and J'.

From this arrangement it will be seen that the currents induced into the armature may be taken off in any position of rotation by employing a suitably-shaped cam, or its equivalent, and thus all the positive currents, or all the negative currents, or both the positive and negative currents, may be readily taken off at will by interposing in the circuit a key K, as shown in figure 2. As connected up in this case, it will be seen that the depression of the key K will send only currents of one direction to line, while the key K, not being pressed, will allow both positive and negative currents to flow to line. It will be convenient, in using this system in telephone exchange lines, to engrave on the key the words "ring off," by which a subscriber will know that, by depressing the key K, he can intimate to the central exchange that he has finished communicating, and wishes his wire to be put straight again.

For this purpose an indicator may be used in the central exchange on the principle shown in figure 3, where M is a curved magnet, held in position by gravity over a coil or coils of wire B. This magnet will not be deflected by the rapidly following positive and negative currents transmitted without pressing the key K; but the moment the key is pressed the magnet is deflected, the contacts H come into the mercury cups N (or into other suitable contacts), and close a local circuit L, in which may be placed a bell-indicator, or other means of attracting the operator's attention.

By using a polarized relay, or other suitable means, the subscriber can disconnect his line from the last subscriber with whom he spoke, and place it back to the operator's switch-board by arranging the relay so that the current transmitted from the magnet when the "ring off" is used shall deflect the tongue of the relay to a stud connected with the switch-board, the tongue being connected to line; other useful combinations may be arranged, as will be evident from the general description herein given. If the curved magnet M be weighted slightly on one side, it may be used without a local circuit and additional apparatus, as the indicator I will fall over when deflected, and remain until put back,

There are numerous other useful applications of this system, for instance, an intermediate station can be arranged with two terminal stations so that the terminals can speak with each other, or with the intermediate station, the switching being done by the station wishing to speak, as will be well understood without further description.

The system is also applicable to the working of electric signals on railways, instead of using batteries, as at present, for example, the "ring off" key, or other suitable arrangement, will enable the operator to transmit the currents so as to indicate "line clear" and "line blocked," or otherwise, as required.

Having thus described our invention, and a suitable manner of carrying the same into effect, we wish it to be understood that what we claim is—

Firstly—The application to or in connection with the axis or spindle of the revolving coil or coils of a magneto-electric call-bell apparatus, of one or more cams, pins, or the like, in combination with suitable contact-springs and connections, whereby, in addition to the ordinary call-signal, a distinct and separate signal may be transmitted to advise the exchange operator that the wires are free, substantially as hereinbefore described.

Secondly—

*Improvements in Electric Signalling Apparatus.*

Secondly.—The employment, in combination with a call-bell apparatus, substantially as herein described, of relays, or other suitable electric apparatus, in the central exchange office, whereby a subscriber to a telephone exchange will be enabled to disconnect his wire from that of the last subscriber with whom he spoke, and place both lines in connection with the switch-board, without the intervention of the operator, substantially as hereinbefore described.

Thirdly.—The application of call-bell apparatus, constructed substantially as hereinbefore described, to the working of electric signals on railways, instead of using batteries, as at present, substantially in the manner described.

In witness whereof, we, the said Louis John Crossley, John Frederic Harrison, and Walter Emmott have hereto set our hands and seals, this seventh day of October, one thousand eight hundred and eighty-two.

LOUIS JOHN CROSSLEY.  
JOHN FREDERIC HARRISON.  
WALTER EMMOTT.

Witness—

WALTER JAS. TURNER.

This is the specification referred to in the annexed Letters of Registration granted to Louis John Crossley, John Frederic Harrison, and Walter Emmott, this nineteenth day of January, A.D. 1883.

AUGUSTUS LOFTUS.

---

**REPORT.**

Sir,

We do ourselves the honor to report, in reply to your blank cover communication of the 4th instant, No. 13,544, that we are of opinion Letters of Registration may be granted in favour of Messrs. L. J. Crossley, John F. Harrison, and Walter Emmott, for an invention entitled "Improvements in Electric Signalling Apparatus, applicable also to other purposes," in terms of their specification, petition, drawings, and claim.

Sydney, 12 December, 1882.

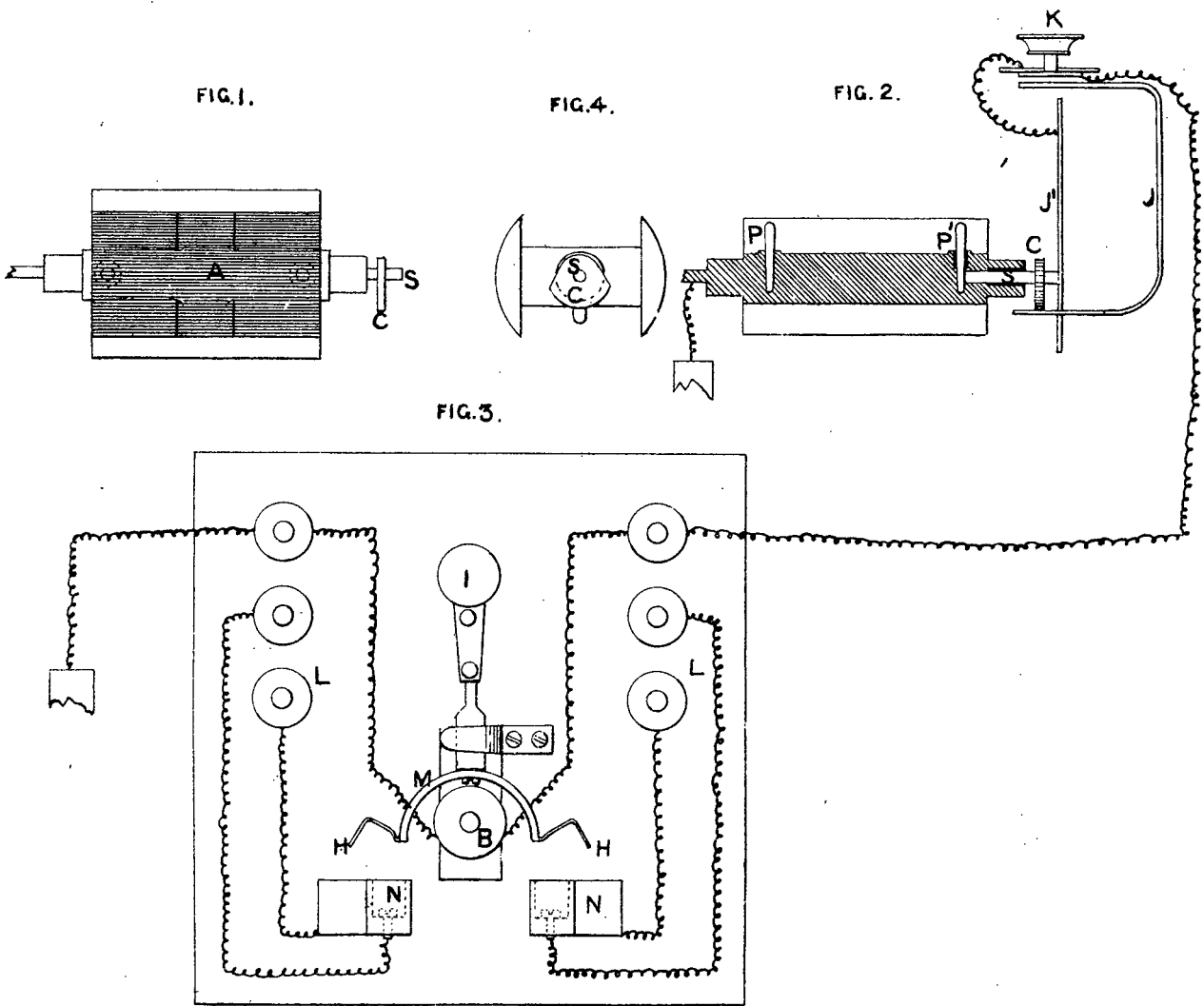
We have, &c.,

E. C. CRACKNELL.  
GOTHER K. MANN.

The Under Secretary of Justice.

---

[Drawings—one sheet.]

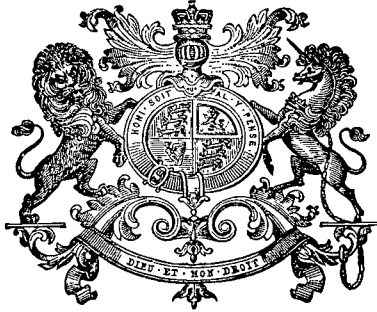


*This is the Sheet of Drawings referred to in the annexed  
 Letters of Registration granted to Louis John Crossley  
 John Frederic Harrison and Walter Emmott this nineteenth  
 day of January A. D. 1883.*

*Augustus Loftus.*

PHOTO-LITHOGRAPHED AT THE GOVT. PRINTING OFFICE,  
 SYDNEY, NEW SOUTH WALES.

*Sig 35.*




---

A.D. 1883, 19th January. No. 1184.

---

IMPROVEMENTS IN DYNAMO-ELECTRIC MACHINES.

LETTERS OF REGISTRATION to John Hopkinson, for an invention entitled  
 "Improvements in Dynamo-Electric Machines."

[Registered on the 19th day of January, 1883, in pursuance of the Act 16 Vic. No. 24.]

BY HIS EXCELLENCY THE RIGHT HONORABLE SIR AUGUSTUS WILLIAM FREDERICK SPENCER LOFTUS (commonly called LORD AUGUSTUS LOFTUS), Knight Grand Cross of the Most Honorable Order of the Bath, a Member of Her Majesty's Most Honorable Privy Council, Governor and Commander-in-Chief of the Colony of New South Wales and its Dependencies.

TO ALL TO WHOM THESE PRESENTS SHALL COME, greeting :

WHEREAS JOHN HOPKINSON, of 4, Westminster Chambers, in the City of Westminster, in England, civil engineer, hath by his Petition humbly represented to me that he is the author or designer of a certain invention or improvement in manufactures, that is to say, of an invention entitled "Improvements in Dynamo-Electric Machines," which is more particularly described in the specification, marked A, and the two sheets of drawing, marked B and C respectively, which are hereunto annexed; and that he, the said Petitioner, hath deposited with the Honorable the Treasurer of the said Colony of New South Wales the sum of Twenty Pounds sterling, for defraying the expense of granting these Letters of Registration, as required by the Act of Council, sixteenth Victoria, number twenty-four; and hath humbly prayed that I would be pleased to grant Letters of Registration, whereby the exclusive enjoyment and advantage of the said invention or improvement might be secured to him for a period of fourteen years: And I, being willing to give encouragement to all inventions and improvements in the arts or manufactures which may be for the public good, and having received a report favourable to the prayer of the said Petition, from competent persons appointed by me to examine and consider the matters stated therein and to report thereon for my information, am pleased, with the advice of the Executive Council, and in exercise of the power and authority given to me by the said Act of Council, to grant, and do by these Letters of Registration grant unto the said John Hopkinson, his executors, administrators, and assigns, the exclusive enjoyment and advantage of the said invention or improvement, for and during the term of fourteen years from the date hereof; to have, hold, and exercise unto the said John Hopkinson, his executors, administrators, and assigns, the exclusive enjoyment and advantage thereof, for and during and unto the full end and term of fourteen years from the date of these presents next and immediately ensuing, and fully to be complete and ended: Provided always, that if the said John Hopkinson shall not, within three days of the granting of these Letters of Registration, register the same in the proper office in the Supreme Court, at Sydney, in the said Colony of New South Wales, then these Letters of Registration, and all advantages whatsoever hereby granted, shall cease and become void.

In witness whereof, I have hereunto set my sign manual, and have caused the present Letters of Registration to be sealed with the seal of the said Colony of New South Wales, at Government House, Sydney, in New South Wales, this nineteenth day of January, in the year of our Lord one thousand eight hundred and eighty-three.

[L.S.]

AUGUSTUS LOFTUS.

*Improvements in Dynamo-Electric Machines.*

SPECIFICATION of JOHN HOPKINSON, of 4, Westminster Chambers, in the City of Westminster, in England, civil engineer, for an invention entitled "Improvements in Dynamo-Electric Machines."

THIS invention has for its object improvements in dynamo-electric machines.

To reduce the sparks which occur between the commutator and the collecting brushes, I divide the collecting brush into parts, and that part which is latest in contact with any section of the commutator passes the current through a resistance, thus gradually checking the current as the contact is broken. The same effect may be obtained by interposing equivalent resistances in the commutator itself.

Where the arrangement of the machine is such that the armature coils lie in planes parallel, or nearly parallel with the plane of revolution of the armature, I construct the armature thus:

The circumference of a pulley is surrounded with a series of layers of sheet iron insulated more or less completely from each other. On one or both sides of the ring thus formed radial slabs are cut to admit the coils of insulated wire which thus lie in planes parallel with the plane of revolution of the pulley. When a continuous current is required I place coils on both faces of the armature and arrange them alternately, so that when one coil is at its dead point, those near to it on the opposite face are producing their maximum effect. The field magnets are made in a manner similar to the armature, though not necessarily with precisely the same number of coils, but it is cheaper to make their cores of solid wrought iron; in some cases I construct them of cast iron. It is advantageous to cut grooves in the face of the iron and to fill up the grooves with insulated sheet iron, so stopping the local currents in the cores which would otherwise occur.

Both in the armature and in the magnets I pack each coil close against its neighbour; each coil is thus of approximately quadrilateral form.

In order that my said invention may be most fully understood and readily carried into effect, I will proceed to describe the drawings hereunto annexed.

## DESCRIPTION OF THE DRAWINGS.

Figures 1 and 2 show a convenient method by which, according to my invention, to reduce the sparks which occur between the commutator and the collecting brushes in continuous current machines; *a a a* are the segments of the commutator insulated from each other; *b' b b* are the collecting brushes or their equivalents carried on a spindle *c*; one of these brushes *b'* is arranged in such wise that there is an electrical resistance between the brush *b'* and the spindle *c*.

This resistance may be made in various ways, but I prefer that shown in the drawing; *d e* are metal cylinders; to *d* the brush is attached, whilst *e* is in contact with the spindle *c*. The space *f*, between *d* and *e*, is filled with a mixture of plumbago and lamp-black, having a suitable resistance; the ends of the space *f* are closed with discs of ivory. The brush *b'* is so adjusted by bending or otherwise that it remains in contact with any segment of the commutator for a short space after the other brushes have left contact with that segment. The effect is, that instead of sudden rupture of continuity of the armature circuit connected to the segment of the commutator, a resistance is first introduced, and contact is not broken till the current has been in some measure reduced. For the more convenient adjustment of the machine I provide several sets of brushes having different resistances, and I ascertain by trial and use that which gives the best result. Instead of interposing a resistance between the brush *b'* and the spindle *c*, the commutator plate may be divided into two parts separated by an appropriate resistance, and the brush *b'* may be in contact with that part which is outside of the resistance. It is clear that the electrical effect will be the same as in the plan more particularly described, and which I prefer.

The collector or commutator which is used when a continuous current is desired I make with the metal pieces to which the wires of the armature are connected air insulated. The metal pieces are carried on insulating discs at their ends, only having air insulation in that part on which the collecting brushes or their equivalents rub.

Figures 3 and 4 show the armature I use in machines arranged so that the coils lie in planes parallel or nearly parallel with the plane of revolution of the armature; *a* is a pulley to be keyed on the shaft of the machine; it is surrounded by a series of layers *b* of sheet iron, more or less insulated from each other. In one or both faces of this ring of layers of iron radial slots are cut for the reception of the coils of insulated wire *c*. The best method of fixing the layers of iron I believe to be the following:— On the pulley I coil a band of sheet iron and of asbestos paper, so that the asbestos paper separates the successive layers of iron from each other. When a sufficient thickness has been obtained radial holes are drilled and bolts *d* are inserted and secured by the collars *e*. If the bolts are put in and collared hot, the layers of iron and paper are very firmly nipped on to the pulley. The radial slots may now be cut. The figures show the armature as arranged for a continuous current, that is with the slots on one side, half way between the slots on the other side of the armature. This is done in order that the current may be more approximately continuous; but when an alternating current is desired the slots in the opposite faces correspond. The connections of the coils with each other may be varied according to the electro motive force desired, as is usual and well understood.

Although I prefer to insulate the layers *b* the one from the other by asbestos paper, the same result will be in part attained by painting the iron composing the layers; and even were the layers superposed without any such precaution, a better result would be obtained than when the armature is made solid and not stratified as described.

Figures 5, 6, and 7 show a complete continuous current machine; *a* is the armature already described; *b b* are the cores of the electro magnets with a strong cast iron backing *c c*. The cores are grooved as shown, and the grooves are fitted with sheet iron either painted or insulated with asbestos paper; *d d* are the exciting coils, the connections of which are so arranged that the poles are alternately north and south, and so that opposite to each north pole I have a south pole; *e* is the commutator.

In place of forming the cores of the electro magnets of cast iron, they may be made from sheet iron coiled and more or less insulated and slotted to receive the coils as described in respect to the armature.

The framing of the machine will be understood by inspection of the drawing.

Figures

*Improvements in Dynamo-Electric Machines.*

Figures 8 to 14 show a machine for generating alternating currents of electricity of low tension but of large quantity or intensity. Figure 8 shows side elevation, and figure 9 end view of the machine. Figure 11 top view with casing broken away. Figure 10 horizontal section. Figure 12 side view of armature. Figure 13 section of same. Figure 14 skeleton framing.

A is a cast iron drum or cylinder having round its circumference several large openings B for the purpose of allowing the air to circulate freely through the interior of the machine to prevent the armature coils becoming unduly heated while the machine is working. Projecting from each end of the drum A is a light bracket or framework C which supports the bearings D of the armature shaft E. Arranged round the interior of said drum are two rows of compound permanent horseshoe magnets F, twelve in each row. Each compound magnet is composed of nine ordinary single horseshoe magnets, clamped firmly together, and held in position in the interior of the drum by the brass or gun metal frame G G. An india-rubber band *a* is joined over the magnet F, and fastened with a bolt as shown. This arrangement produces a powerful magnetic field in which, and in close proximity to the magnets, the armature H revolves, figures 11 and 12.

This armature is made in the following manner:—On the shaft E, figure 13, is fixed a small pulley I of iron, brass, or gun metal. Around this pulley there is coiled as tightly as possible strips of thin sheet iron J, figure 13, having between each layer an insulating material composed of asbestos. It is not absolutely necessary to use asbestos, as the strips of iron may be simply painted, or even coiled, without any insulating material, but better results are obtained when some such material is used. When the desired diameter has been obtained the iron bands are secured to the pulley I by means of several bolts, collars K, which pass through a hole drilled through the entire mass of the armature into the pulley I. The bolts are made hot before being put in their places, so that the iron bands may be more firmly clamped together when the bolts cool and contract.

Radial slots L, figure 12, are cut on both faces of the armature for the reception of the coils.

A number of thicknesses of copper tape or wire M, figures 11 and 12, spun over with silk or cotton to insulate it, are now wound round the armature on both faces in a zig zag or serpentine manner until the radial slots L are completely filled up. A hole is made in the armature disc, through which the inner ends of the copper tape are passed and connected together by soldering or otherwise, so as to form one continuous conductor. After completing the winding the outer ends of the said copper tape or wire on either side are taken to the shaft E, along which it is carried to the commutator N, figures 9, 10, and 11.

The commutator shown in section, figure 13, is composed of a dry wooden boss O, securely fastened to the shaft E, and having round its circumference two thick rings of copper or brass P insulated from each other. The two free ends of the armature wires or tape are secured one to each of these rings. Brushes composed of thin strips of copper Q, firmly secured by clamps K and in electrical connection with the two terminal screws S, press on to the two commutator rings P and collect the electricity as it is generated by the armature. The brushes, clamps, and terminal screws are insulated from each other, and the metal work of the machine by the two wooden blocks T T, figure 11, to which they are securely fastened.

Having thus described the nature of my invention, and in what manner it is to be carried into effect, I claim:—

- First—In a continuous current dynamo-electric machine the introduction of a resistance in the commutator before breaking contact in the manner herein described or electrically equivalent thereto.
- Second—The armature, whether for continuous or alternating currents, consisting of superposed rings or layers of sheet iron with radial grooves for the coils, the coils lying in planes perpendicular, or nearly perpendicular, to the axis of rotation, substantially as herein described.
- Third—The field magnets, whether for continuous or alternating currents, having cores consisting either of superposed layers of sheet iron or of cast iron grooved and inlaid with sheet iron provided with coils, and arranged substantially as herein described.
- Fourth—In an alternating current dynamo-electric machine constructing the armature with the tape or wire M wound in a zig zag or serpentine manner as shown in figure 12 of my drawings.
- Fifth—The dynamo-electric machines herein described and shown, whether arranged for continuous or alternate currents.

In witness whereof, I, the said John Hopkinson, have hereto set my hand and seal, this seventeenth day of November, one thousand eight hundred and eighty-two.

JOHN HOPKINSON,  
(By his agent, JULIUS VOGEL.)

Witness—  
EDWD. WATERS,  
Melbourne, Patent Agent.

This is the specification marked A. referred to in the annexed Letters of Registration granted to John Hopkinson, this nineteenth day of January, A.D. 1883.

AUGUSTUS LOFTUS.

REPORT.

---

*Improvements in Dynamo-Electric Machines.*

---

## REPORT.

Sir,

Sydney, 5 December, 1882.

We do ourselves the honor to report, in reply to your blank cover communication of the 22nd ultimo, No. 13,230, that we are of opinion that Letters of Registration may be granted to Mr. John Hopkinson, for an invention entitled "Improvements in Dynamo-Electric Machines," in terms of his petition, specification, drawings, and claim.

The Under Secretary of Justice.

We have, &amp;c.,

E. C. CRACKNELL.  
GOTHER K. MANN.

---

[Drawings—two sheets.]



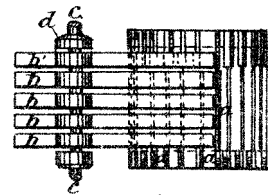


Fig. 1.

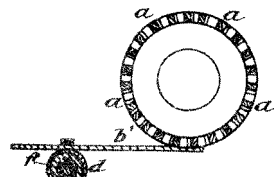


Fig. 2.

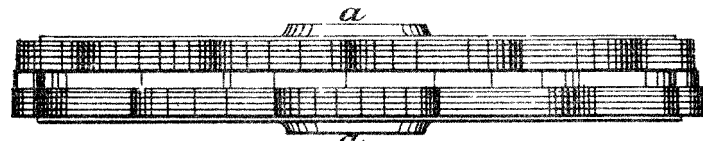


Fig. 3.

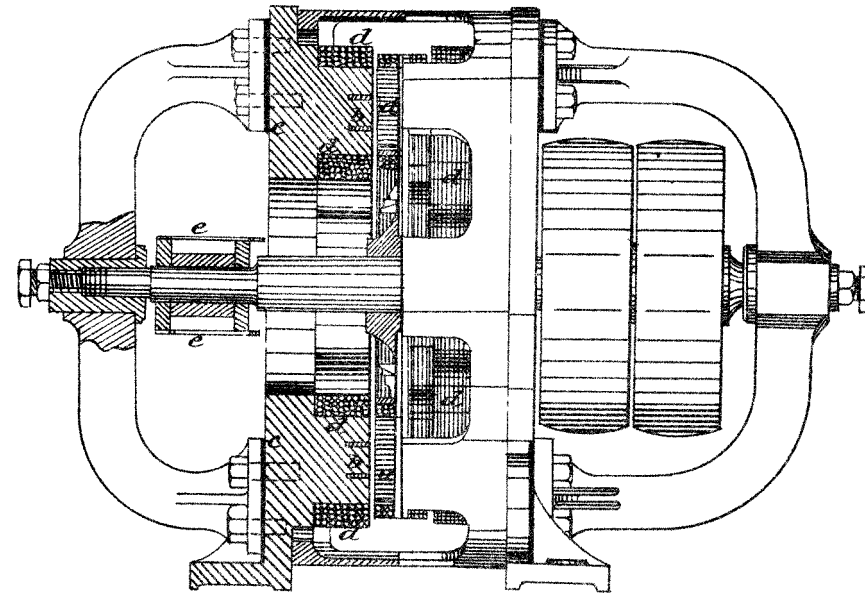


Fig. 5.

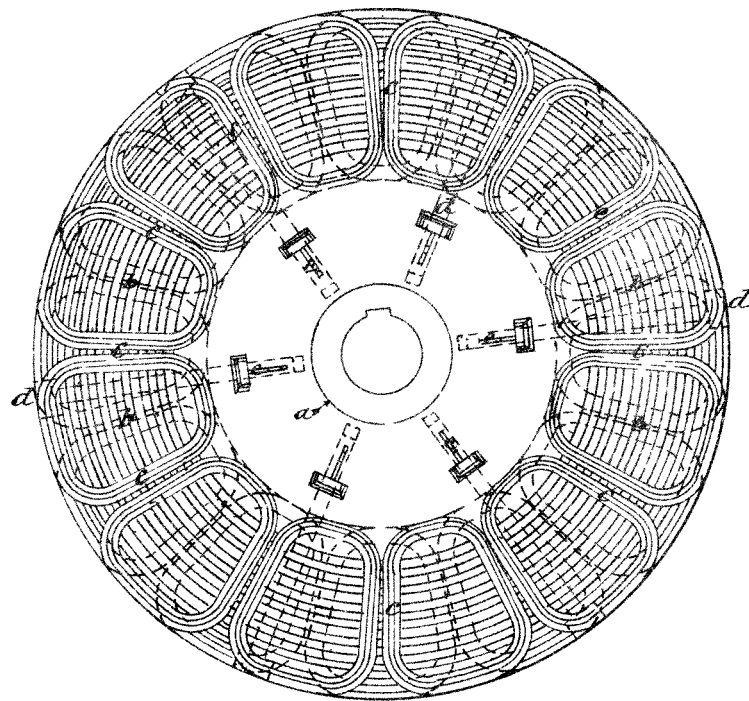


Fig. 4.

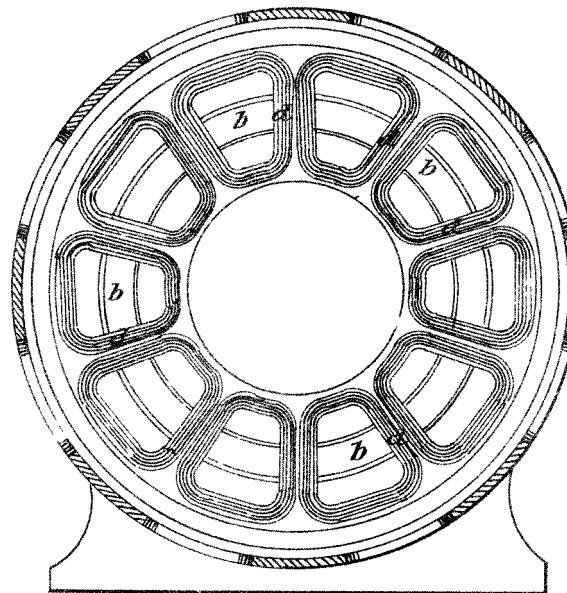


Fig. 6.

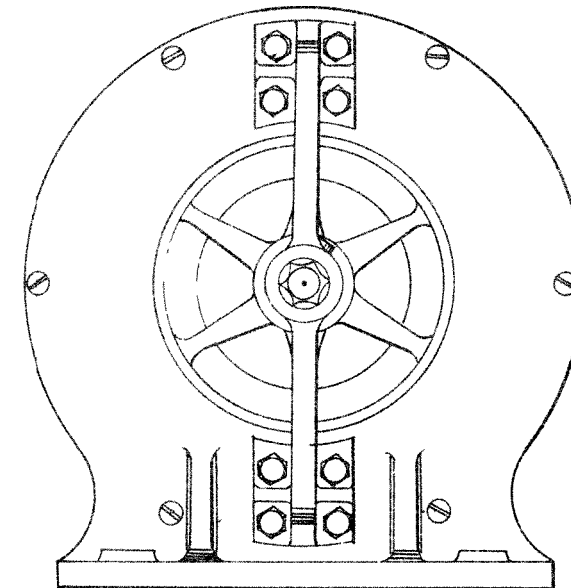


Fig. 7.

*This is the Sheet of Drawings marked B. referred to in the annexed Letters of Registration granted to John Hopkinson this nineteenth day of January A.D. 1883.*

*Augustus Loftus.*

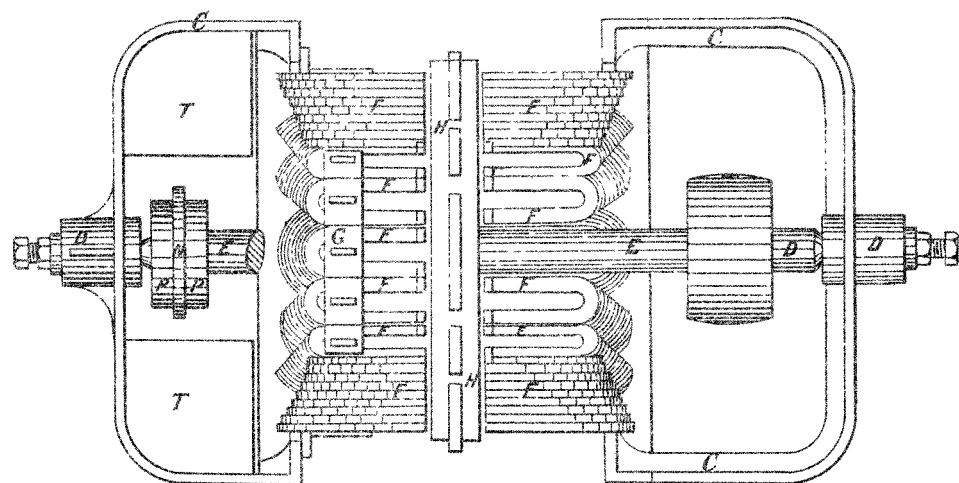


Fig. 10.

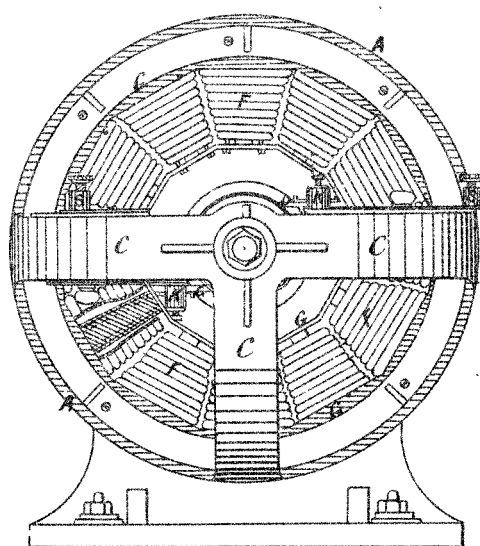


Fig. 9.

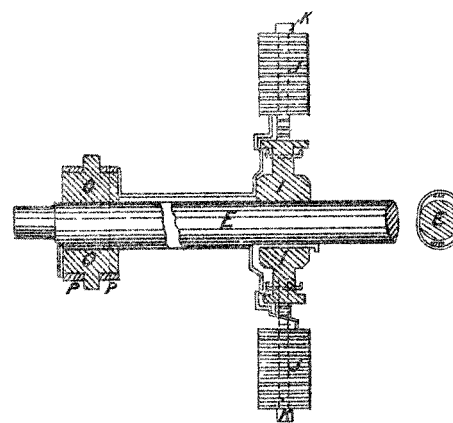


Fig. 13.

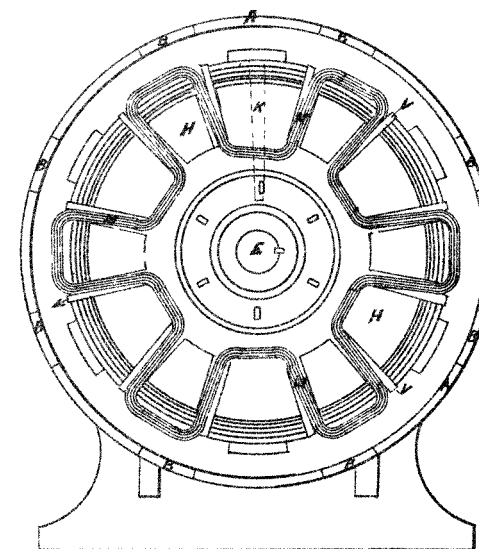


Fig. 12.

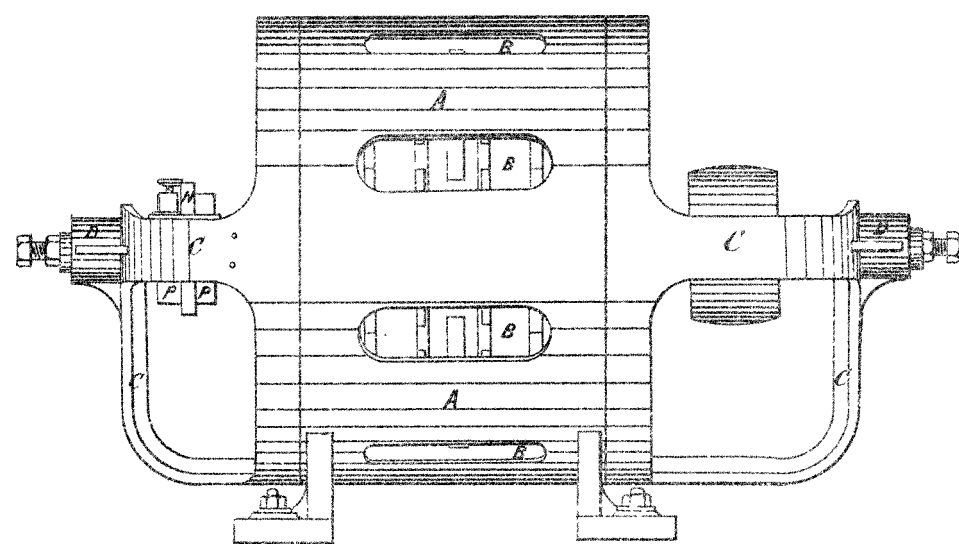


Fig. 8.

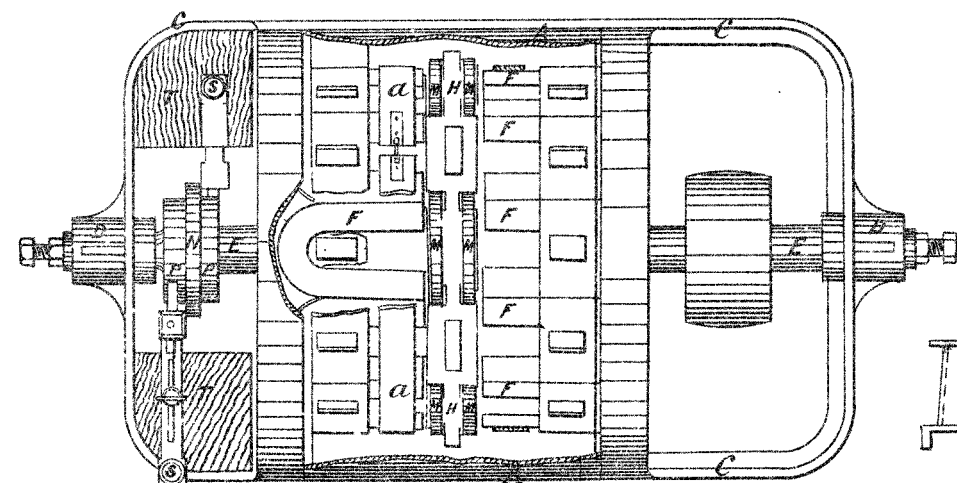


Fig. 11.

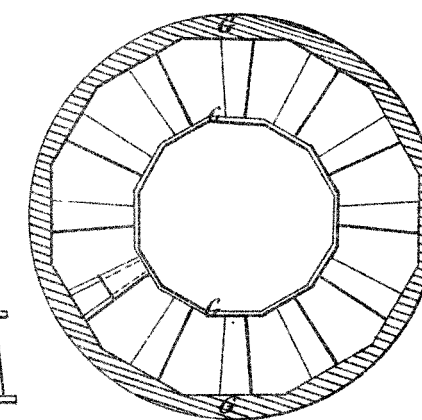


Fig. 14.

*This is the Sheet of Drawings marked C referred to in the annexed  
Letters of Registration granted to John Hopkinson, this nineteenth  
day of January A. D. 1883.*

*Augustus Loftus.*



A.D. 1883, 19th *January*. No. 1185.

IMPROVEMENTS IN ORE FURNACES.

LETTERS OF REGISTRATION to John Campbell, for Improvements in Ore Furnaces.

[Registered on the 19th day of January, 1883, in pursuance of the Act 16 Vic. No. 24.]

BY HIS EXCELLENCY THE RIGHT HONORABLE SIR AUGUSTUS WILLIAM FREDERICK SPENCER LOFTUS (commonly called LORD AUGUSTUS LOFTUS) Knight Grand Cross of the Most Honorable Order of the Bath, a Member of Her Majesty's Most Honorable Privy Council, Governor and Commander-in-Chief of the Colony of New South Wales and its Dependencies.

TO ALL TO WHOM THESE PRESENTS SHALL COME, greeting :

WHEREAS JOHN CAMPBELL, of the city and county of San Francisco, State of California, one of the United States of America, Doctor of Medicine, hath by his Petition humbly represented to me that he is the author or designer of a certain invention or improvement in manufactures, that is to say, of an invention entitled "Improvements in Ore Furnaces," which is more particularly described in the specification and the sheet of drawings which are hereunto annexed; and that he, the said Petitioner, hath deposited with the Honorable the Treasurer of the said Colony of New South Wales the sum of Twenty Pounds sterling, for defraying the expense of granting these Letters of Registration, as required by the Act of Council, sixteenth Victoria, number twenty-four; and hath humbly prayed that I would be pleased to grant Letters of Registration, whereby the exclusive enjoyment and advantage of the said invention or improvement might be secured to him for a period of fourteen years: And I, being willing to give encouragement to all inventions and improvements in the arts or manufactures which may be for the public good, and having received a report favourable to the prayer of the said Petition, from competent persons appointed by me to examine and consider the matters stated therein and to report thereon for my information, am pleased, with the advice of the Executive Council, and in exercise of the power and authority given to me by the said Act of Council, to grant, and do by these Letters of Registration grant unto the said John Campbell, his executors, administrators, and assigns, the exclusive enjoyment and advantage of the said invention or improvement, for and during the term of fourteen years from the date hereof; to have, hold, and exercise unto the said John Campbell, his executors, administrators, and assigns, the exclusive enjoyment and advantage thereof, for and during and unto the full end and term of fourteen years from the date of these presents next and immediately ensuing, and fully to be complete and ended: Provided always, that if the said John Campbell shall not, within three days after the granting of these Letters of Registration, register the same in the proper office in the Supreme Court, at Sydney, in the said Colony of New South Wales, then these Letters of Registration, and all advantages whatsoever hereby granted, shall cease and become void.

In witness whereof, I have hereunto set my sign manual, and have caused the present Letters of Registration to be sealed with the seal of the said Colony of New South Wales, at Government House, Sydney, in New South Wales, this nineteenth day of January, in the year of our Lord one thousand eight hundred and eighty-three.

[L.S.]

AUGUSTUS LOFTUS.

*Improvements in Ore Furnaces.*

SPECIFICATION of JOHN CAMPBELL, of the city and county of San Francisco, State of California, one of the United States of America, M.D., for an invention entitled "Improvements in Ore Furnaces."

THIS invention relates to those descriptions of ore furnaces which are commonly called "shaft furnaces," because their principal part consists of a vertical shaft, and my said invention consists, first, in two novel methods of feeding the ore to such furnaces, and secondly, to a novel method of supplying the heat to such furnaces. Ordinarily, the feed is supplied from the top and allowed to fall in one continuous drop (sometimes interrupted by shelves) to the bottom. Now, one of my novel methods of feeding is to supply the material from the lower part of the stack and to blow it up the stack in a fountain, the heavier parts of which descend again, but the lighter parts of which are carried over the top and down a descending flue into the precipitating chambers. Another of my novel methods of feeding is to supply the material from near to but not at the top, and so to direct it that it shall strike one of the sides of the shaft at such an angle as to make it fly off at a tangent, and obtain a centrifugal or approximately centrifugal motion. The feed in each instance being accompanied by a blast of compressed air or steam. In this latter method of feeding, the ore has a tendency to matt on the sides of the furnace, but that which neither matts nor falls to the bottom is blown over to the descending flue and carried to the precipitating chambers as before. Ordinarily, the heat is supplied to such furnaces by means of fires at or adjacent to their base; but I supply such heat from liquid hydro-carbon injectors fitted at or about the level of the lower ore feed, so that when the feed is blown up the stack, it has to pass upward and downward through the flame, thereby giving every opportunity for the oxidizing of the baser metals which are carried by the current into the descending flues leading to the precipitating chambers; and when the feed is downward, the winding-course of its descent gives much greater opportunity for such oxidization than if it fell from top to bottom; and further, the hydro-carbon flame is more intense and direct than the heat from a furnace of ordinary fuel, and is at the same time more completely under control.

It is well understood that the liquid hydro-carbon is to be supplied in the usual way with either steam alone or steam and air combined, and that the ore is to be first thoroughly crushed before it is fed into the furnace.

Referring to my drawings, figure 1 shows vertical section of a furnace constructed according to my invention, and figure 2 vertical section at right angles to figure 1. A is the shaft of the furnace; C the upper feed; C<sup>1</sup> compressed air or steam-pipe leading therein; C<sup>2</sup> the lower feed, and C<sup>3</sup> the compressed air or steam-pipe leading therein; D is the liquid hydro-carbon supply-pipe; D<sup>1</sup> the openings in the sides of the furnace therefor, the top of such openings being inclined upwards so as to allow of the flame readily assuming that direction; E is the descending flue leading to the precipitating chambers; F, of which only one is shown, but of which there may be as many as may be desired, and in which the precipitation may be induced by any of the methods or contrivances now in use for that purpose.

The air and steam supply-pipes, for the hydro-carbon injector and for the respective feeds, may be conducted through the wall of the furnace-shaft to its interior and exposed in the form of a coil, or otherwise, to the high temperature therein, so as to heat the air or super-heat the steam as it passes either into the hydro-carbon injector or into the feed injectors, as the case may be.

In operation, the crushed ore is fed to either of the feed hoppers C or C<sup>2</sup>, together with a blast of compressed air or steam through pipe C<sup>1</sup> or C<sup>3</sup>, and the liquid hydro-carbon is supplied together with steam and either with or without air through pipe D. If the ore is fed through C<sup>2</sup>, it is carried upward in a shower through the hydro-carbon flame, being partly oxidized in the process, and falling down again through the flame by its own gravity is again subjected to its oxidizing influence, the oxidizable portion having been carried away by the force of the current to the descending flue E, to be conducted to the precipitating chambers F, whilst the remainder is deposited in the pit A<sup>1</sup> of the furnace. If the ore is fed through C<sup>1</sup>, it only passes once although by a circuitous course through the flame, part of it forming a matt on the sides, other part descending into the pit A<sup>1</sup>, whilst the oxidizable portion is as before carried away through descending flue E into the precipitating chambers F.

Having thus described the nature of my invention, and the manner of performing the same, I would have it understood that I do not claim to be the inventor of stack furnaces for treating ores, but that what I do claim as my improvements in ore furnaces is:—

First—The two several methods of feeding ore to shaft furnaces—(1st) from an injector in the lower part of such shaft, as at C<sup>2</sup>, and (2nd) from an injector in the upper part of such shaft, as at C, in each case by means of a blast of compressed air or steam, substantially as herein described and explained.

Second—The method of supplying the heat to such shaft furnaces by means of liquid hydro-carbon conveyed through injectors, the hydro-carbon being always accompanied by a steam jet and sometimes with a blast of air, such injectors being by preference just above the pit and at or near the lower end of the shaft, substantially as herein described and explained.

In witness whereof, I, the said John Campbell, have hereto set my hand and seal, this twenty-second day of November, one thousand eight hundred and eighty-two.

(L.S.) JOHN CAMPBELL,

By his duly authorized Attorney,

J. H. CUSHING.

Witness—

EDWD. WATERS,  
Melbourne, Patent Agent.

This is the specification referred to in the annexed Letters of Registration granted to John Campbell, this nineteenth day of January, A.D. 1883.

AUGUSTUS LOFTUS.

REPORT.

---

*Improvements in Ore Furnaces.*

---

REPORT.

Sir, Sydney, 4 December, 1882.  
The application of Mr. John Campbell, for Letters of Registration for "Improvements in Ore Furnaces," having been referred to us, we have examined the specification and drawings accompanying the same, and have now the honor to report that we see no objection to the issue of Letters of Registration, as prayed for.

The Under Secretary of Justice.

We have, &c.,  
A. LEIBIUS.  
CHAS. WATT.

---

[Drawings—one sheet.]

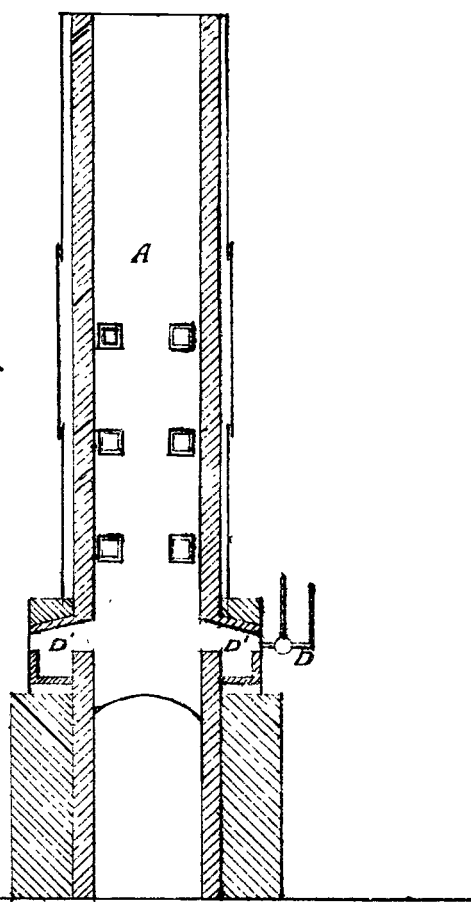


Fig. 1.

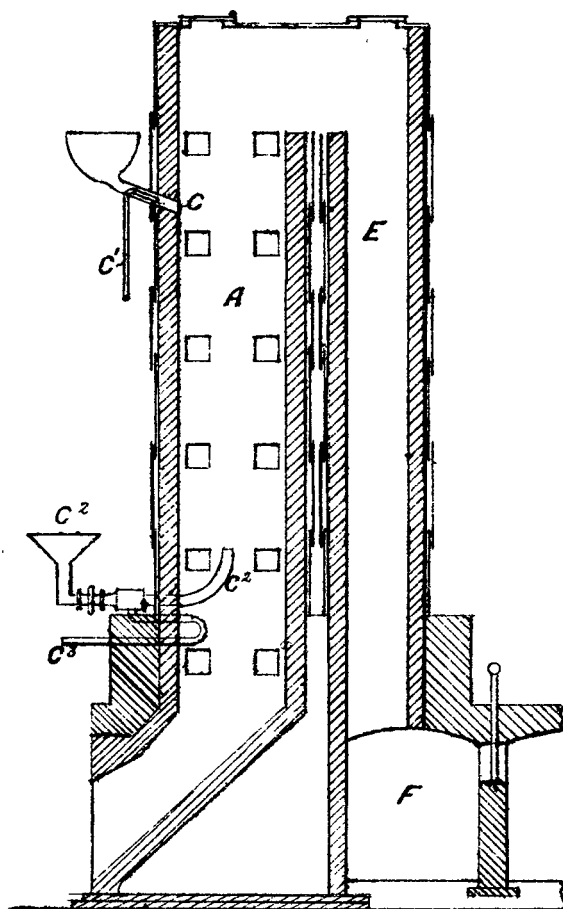
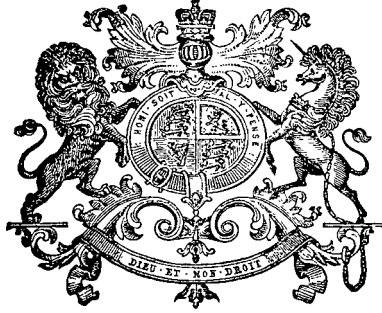


Fig. 2.

*This is the Sheet of Drawings referred to in the annexed  
Letters of Registration granted to John Campbell this  
Nineteenth day of January A.D. 1883.*

*Augustus Loftus*




---

A.D. 1883, 19th *January*. No. 1186.

---

**IMPROVEMENTS IN DYNAMO-ELECTRIC MACHINES.**

**LETTERS OF REGISTRATION to James Edward Henry Gordon, for Improvements in Dynamo-electric Machines.**

[Registered on the 19th day of January, 1883, in pursuance of the Act 16 Vic. No. 24.]

BY HIS EXCELLENCY the RIGHT HONORABLE SIR AUGUSTUS WILLIAM FREDERICK SPENCER LOFTUS (commonly called LORD AUGUSTUS LOFTUS), Knight Grand Cross of the Most Honorable Order of the Bath, a Member of Her Majesty's Most Honorable Privy Council, Governor and Commander-in-Chief of the Colony of New South Wales and its Dependencies.

TO ALL TO WHOM THESE PRESENTS SHALL COME, greeting :

WHEREAS JAMES EDWARD HENRY GORDON, of Kensington, in the county of Middlesex, England, hath by his Petition humbly represented to me that he is the author or designer of a certain invention or improvement in manufactures, that is to say, of an invention entitled "Improvements in Dynamo-electric Machines," which is more particularly described in the specification marked A, and the two sheets of drawings marked B and C respectively, which are hereunto annexed ; and that he, the said Petitioner, hath deposited with the Honorable the Treasurer of the said Colony of New South Wales the sum of Twenty Pounds sterling, for defraying the expense of granting these Letters of Registration, as required by the Act of Council, sixteenth Victoria, number twenty-four ; and hath humbly prayed that I would be pleased to grant Letters of Registration, whereby the exclusive enjoyment and advantage of the said invention or improvement might be secured to him for a period of fourteen years : And I, being willing to give encouragement to all inventions and improvements in the arts or manufactures which may be for the public good, and having received a report favourable to the prayer of the said Petition from competent persons appointed by me to examine and consider the matters stated therein and to report thereon for my information, am pleased, with the advice of the Executive Council, and in exercise of the power and authority given to me by the said Act of Council, to grant, and do by these Letters of Registration grant unto the said James Edward Henry Gordon, his executors, administrators, and assigns, the exclusive enjoyment and advantage of the said invention or improvement, for and during the term of fourteen years from the date hereof ; to have, hold, and exercise unto the said James Edward Henry Gordon, his executors, administrators, and assigns, the exclusive enjoyment and advantage thereof, for and during and unto the full end and term of fourteen years from the date of these presents next and immediately ensuing, and fully to be complete and ended : Provided always, that if the said James Edward Henry Gordon shall not, within three days after the granting of these Letters of Registration, register the same in the proper office in the Supreme Court, at Sydney, in the said Colony of New South Wales, then these Letters of Registration, and all advantages whatsoever hereby granted, shall cease and become void.

In witness whereof, I have hereunto set my sign manual, and have caused the present letters of Registration to be sealed with the seal of the said Colony of New South Wales, at Government House, Sydney, in New South Wales, this nineteenth day of January, in the year of our Lord one thousand eight hundred and eighty-three.

[L.S.]

AUGUSTUS LOFTUS.

*Improvements in Dynamo-electric Machines.*

A.

SPECIFICATION of JAMES EDWARD HENRY GORDON, of Kensington, in the county of Middlesex, England, for an invention entitled "Improvements in Dynamo-electric Machines."

THIS invention has for its object improvements in dynamo-electric machines, applicable more especially for electric lighting.

My machine consists of an iron or steel disc or wheel, which is caused to revolve by a steam engine or other motor. Near the edge of the disc are holes equidistant from each other and from the axis. In each hole a cylindrical bar of soft iron is fixed so that it is parallel to the axis and projects equally on each side of the disc. Bobbins carrying insulated copper wire are slipped on to the projecting portions of each bar, and are held on by iron plates fixed on the ends of the bars, and forming pole pieces. The bobbins being connected together, the current from a separate small direct current machine called the exciter is sent through them, so that the iron bars become electro-magnets. When the wheel is in motion the connection with the exciter is made by rubbing contacts in the usual manner. The bobbins are so connected that the end of a bar on one side of the disc has an opposite polarity to the other end on the other side and that on the same side of the disc, the ends of the bars have N and S polarities alternately. Each pair of half bars projecting from either side thus form a horse-shoe electro-magnet, of which the disc forms the "yoke."

On either side of the revolving disc is a stationary iron ring fixed to the frame of the machine and carrying the armature bobbins in which the current is to be generated. The fixed and revolving rings are sensibly of the same diameter. The armature bobbins consist of straight, soft iron cores of a construction to be described below, with insulated wire wound on them. The cores are parallel to the axis of the machine and their centres are all at the same distance from its centre as the centres of the iron cores of the electro-magnets in the revolving disc, so that as the core of an electro-magnet passes the core of an armature coil the two cores are in the same straight line.

One end of each armature bobbin is therefore acted on by the moving magnet poles, and the other is bolted to the fixed iron ring which forms a common "yoke" to all the armature bobbins.

I have discovered that if there are the same number of armature coils on each stationary ring as there are magnet poles acting on it, the coils act on each other by mutual induction in a very injurious manner during the working of the machine.

If a certain number of lamps are being maintained by one coil, closing the circuit of the next to it on one side, reduces the light of the lamps on the first by some 20 or 30 per cent. Closing the circuit of the next on the other side still further reduces it by a like amount. The reason is that as the currents in contiguous coils circulate in opposite directions, they are in the same direction in those parts of the two coils which are immediately contiguous to each other. As the currents in the two coils are both increasing at the same time they retard each other by their mutual action.

I avoid this by making the number of armature coils in each ring twice the number of the magnet coils. The magnets therefore act alternately on the alternate sets of coils. For instance if thirty-two magnets are carried by the wheel so that there are thirty-two poles on each side of it, I should place sixty-four armature coils on each stationary ring, then at the instant when the thirty-two magnets are having their maximum action on the alternate coils 1, 3, 5, up to 63, the other alternate coils 2, 4, 6, up to 64, are practically idle; 1 and 5 still tend to act injuriously on 3 as before, but being separated from it by the thickness of coils 2 and 4, their action is so small as to be unnoticeable; 1 and 3 induce electromotive forces in the two sides of 2 respectively, but these are equal and in opposite directions, and so produce no current or change of current in 2.

In coupling several coils together, either in quantity or series, those coils only which belong to the same set of alternate coils should be coupled. For instance, if it were desired to connect coil 1 with two other coils, 3 and 5 would be used, and not 2 and 4.

In working the machine separate coils or groups of coils may, if desired, be used for a number of separate circuits, but for incandescent lighting it is best to combine all the even numbered coils into one circuit and all the odd numbered ones into another. The coils in each circuit may be connected in series or quantity, or in any combination of the two that suits the lamps.

In order to economise space and get more wire on the machine the fixed coils are made wedge-shaped, the sides of the wedge being planes radial to the axis of the fixed ring that carries them.

The improvement of employing twice as many coils in each armature ring as there are magnets in the magnet wheel is applicable not only to dynamo machines constructed as hereinbefore described, but also to all dynamo machines in which the cores of the electro-magnets and of the armature coils are straight and parallel with the axis of the machine, whether the circle of the magnets be carried by the revolving axis whilst the circle of armature coils are fixed, or whether the circle of armature coils are carried by the revolving axis whilst the circle of magnets are fixed as in the well-known Siemens dynamo machine commonly used for producing alternate currents, and whether the armature coils have iron cores or not. The various parts of the machine I construct in the manner hereinafter more fully described.

Figure 1 shows a side elevation, figure 2 an end elevation, and figure 3 a plan of a machine constructed according to my invention. One half of each of the above figures is shown in section. Figure 4 shows a section of one of the fixed rings and one of the armature coils carried by it; figure 5, an elevation of part of one of the fixed rings—the way in which each armature coil is built up and secured to the ring is illustrated in this figure; figures 6, 7, and 8 show full-sized views of one of the armature coils; and figures 9 and 10, full-sized views of one of the magnets.

The machine represented in the drawings is of very large size, and is intended to be driven direct from a steam engine without belt or other multiplying gear.

The machine shown in the drawings hereunto annexed is constructed to work 6,000 swan lamps of 20-candle power each. The revolving wheel is 8 feet diameter at the magnet centres. The sole plate is 13 feet 4 inches long by 7 feet wide. These dimensions, however, are only the dimensions of a particular machine, and are not the only useful dimensions, as the machine may be made either smaller or larger as desired.

The



*Improvements in Dynamo-electric Machines.*

The wheel is built up of wrought-iron boiler plates, though steel plates might be used.

The wheel consists of two central discs A, and of two cones B, whose bases fit upon the central discs, and through whose apices the main shaft C passes.

The discs A and cones B are made of segmental pieces of boiler plate, so cut that the grain of the plate is radial to the wheel at the centre of each segment. The segments are riveted together with butt strips in the way usual in boiler-making.

The discs A are kept apart at the centre by a cast-iron distance piece D. At the rim they are kept apart by a wrought-iron ring E. The cones B are of less diameter than the discs, so as to leave a space of flat disc all round exterior to the cones. The cones and disc are separated at the centre by massive cast-iron bosses F, turned square to the shaft, where they butt against the disc, and conical, where they butt against the cones. The cast-iron distance piece D is of somewhat larger diameter than the bosses, so that the discs can be riveted to it without the heads of the rivets interfering with the bosses. The cones, discs, ring distance piece, and bosses are all firmly riveted and bolted together, being still further strengthened by angle pieces (not shown in the drawings) placed between the disc and the cones.

The discs are riveted with double butt strips, the cones with single ones. The butt strips of the cones are placed inside them, and the rivet heads countersunk so that the outsides of the cones have perfectly smooth surfaces.

The flat outer portion of the wheel receives the magnets G, which in the machine from which these drawings are taken are thirty-two in number.

Each magnet consists of a cylindrical iron core G<sup>1</sup>, of two bobbins G<sup>2</sup> of brass or other metal other than iron containing wire, and of two pole pieces G<sup>3</sup>. The core G<sup>1</sup> passes right through a hole in the discs A and wrought-iron ring E, and is fixed so as to project equally on both sides. The brass bobbins are then slipped on, one at each side of the disc, and the pole plates being fixed on, hold the bobbins in their places. The pole plates are of iron, preferably wrought; their sides are not parallel, but form radii of the magnet wheel.

One method of securing the cores and pole plates is shown in the drawings, but other methods may be used.

The shaft C runs in bearings preferably of phosphor bronze, which are carried by the side frames H.

There is a large gap or opening, I<sup>1</sup>, in the sole plate I, through which a portion of the wheel dips into a pit below the machine. This enables the centre of gravity to be kept low, and greatly increases the stability of the machine.

The end thrust is taken by two loose iron collars, K, placed on the shaft and pressed gently against the inside ends of the phosphor bronze journals by means of set screws projecting from the ends of the cast-iron bosses. These set screws are secured by lock nuts.

The collars, K, also carry the contact rings, L, for conveying the exciting current to the magnets. The rings are preferably of phosphor bronze, and are separated from the iron collars by split rings of vulcanite or other insulator. Brushes not shown in the drawing press on them in the ordinary way to convey the exciting current to them. M are fixed rings of cast-iron carrying the fixed coils. They are supported by being bolted to the inside of the gap in the sole plate at M<sup>1</sup> M<sup>1</sup> and by the four cast-iron struts, M<sup>2</sup>. They are also tied together by the seven screwed rods M<sup>3</sup>.

Each fixed ring is made in three segments, one being much smaller than either of the other two. This is for the reason that if one of the magnet coils breaks down it can readily be got at by removing the small segment of one of the fixed rings and turning the wheel until the damaged coil comes opposite to the gap so produced in the ring, the damaged coil can thus quickly be removed and replaced by another one.

64 fixed coils are fixed to each ring so that the 64 poles facing the magnet wheel are acted on by the 32 magnet poles facing them, the number of coils thus being twice the number of magnets as hereinbefore stated. The magnet poles on either side of the wheel are also as before stated alternately north and south.

The details of the fixed coils are shown on a larger scale in figures 6, 7, and 8.

The wedge shaped core, N, consists of a sheet of boiler plate bent upon itself so that the angle forms the thin edge of the wedge and the free edges which do not quite meet from the thick end.

The wedge shaped head of a T piece, O, is inserted into one end of the folded plate and welded to it, and the stem of the T being turned and screwed is passed through a hole in the fixed ring and is secured by lock nuts, O<sup>1</sup>.

Another method of construction is to weld in merely a wedge shaped block and to tap a screw hole in it and to secure it by a stud bolt screwed in from the back of the fixed ring. This enables a damaged coil to be removed without removing the heavy fixed ring.

A closed channel may be made at the back of each fixed ring, through which a stream of water can be made to flow and to return all waste heat to the feed water of the boiler.

In order that power may not be wasted in inducing currents in the plate M a wide space is left between the wire of the coils and the plate. This space may be filled up with wooden plates or blocks, P, which form the outer flange of the coil. These wooden blocks may be from one inch to three or more inches in thickness. They are 3 inches thick in the machine from which the drawings are taken. This improvement may be applied to any machine where the inducing magnets act on one end of the iron cores of the armatures whilst the other ends are secured to an iron plate or plates. The wood block is also useful to carry binding screws to which the ends of the wire are fixed. The wooden block, P, hereinbefore mentioned is slipped on to the core, and secured by one or more pins.

Q is a flange of German-silver riveted on to a shoulder cut on the end of the core. In addition to the slots which are cast in it, a cut, Q<sup>1</sup>, is made, passing completely through into the opening of the core. Projecting lugs, Q<sup>2</sup>, are cast on the German-silver which clip into the opening in the core and prevent the slot, Q<sup>1</sup>, from opening. The flange may be further secured by being made to project beyond the wire in places, Q<sup>3</sup>, and being secured to the wood by long screws and wooden distance pieces. These screws must of course be inserted after the wire is wound. I find it of great advantage to make the flanges of the fixed coils which are next to the magnet poles of German-silver as above described, as it is very rigid and opposes high resistance to the circulation of electric currents in it.

RR represent the holding down bolts.

The

*Improvements in Dynamo-electric Machines.*

The shaft is coupled direct to a steam engine or to two steam engines, one at each end.

In the machine from which the drawings are taken the wire, both on magnets and on armature coils, is .185 inch in diameter.

The magnets may be excited by a direct current produced in any ordinary way.

The following is the method which I use for regulating my machine so as to keep the electro-motive force constant when the number of lamps on it is varied.

The exciter is driven by a small separate steam-engine so that its speed can be varied independently of that of the large machine.

The coils are all connected into two main circuits—one composed of all the even numbered coils, and the other of all the odd numbered ones.

I usually paint the alternate coils red and blue respectively, and then speak of the two circuits as the red and blue respectively. The switches, wires, &c., of each circuit are coloured to correspond.

A dark room is constructed near the machine, and the steam-pipes of the large and small engines pass through it. Stop valves with large hand wheels are placed in each pipe.

Near the wheels is the screen of a photometer, in which is placed a standard candle and a sample lamp from each circuit. The lamps can be lighted alternately by switches.

In a convenient position are also a strophometer for showing the speed of the large engine, an Ayrton's animeter for showing the strength of the exciting current and a steam pressure gauge.

The big machine being set to its proper speed the exciter is started, and its speed gradually increased till the photometer shows that the lamps are of the right candle power.

If there were any very great difference in the number of lamps on each circuit the circuit which had the fewest lamps on it would be brightest. In practice no such great difference in the number of lamps occurs when the machine is large and care is taken to select the same class of houses for supply from each circuit. The small adjustment required is made by means of the street lamps near the machine, which by means of switches can be instantly transferred 50 or 100 at a time from the dimmer circuit to the brighter one.

Having now described my invention, I would have it understood that what I claim is—

First—My improved dynamo-electric machine for electric lighting, composed of stationary armature bobbins and electro-magnet bobbins mounted upon an iron or steel wheel, the axes of the said bobbins being straight and parallel to the axis of the wheel, and so arranged that as the wheel revolves the electro-magnets are carried past the induction bobbins end to end, substantially as herein described.

Second—In dynamo machines, in which the cores of the electro-magnets and of the armature bobbins are straight and parallel with the revolving axis of the machine I claim to make, the number of armature bobbins in each ring double the number of the electro-magnets in the magnet ring whether the armature bobbins are fixed and the magnets carried by the revolving axis or *vice versa*.

Third—I claim the improvement in dynamo machines applicable to all machines where one end of each armature core is acted on by the magnets and the other ends of the cores are connected by an iron plate consisting in lengthening the cores beyond the length required for the wire, and thus setting back the iron plate into a field of greatly diminished inductive action.

Fourth—The construction of the flanges of the fixed coils which are next to the magnets of German-silver for the purpose described.

Fifth—The construction of the flanges of the fixed coils with a slit through their outer end and with lugs projecting from the edges of the slit to enter an opening in the core substantially as described.

Sixth—In the construction of the revolving wheel of dynamo machines the combination of the two discs, A, distance piece, D, ring, E, electro-magnets, G, coned bosses, F, and coned plates, B, substantially as described.

Seventh—The combination of the ring, E, the iron cores, G<sup>1</sup>, projecting from either side of it, the bobbins, G<sup>2</sup>, slipped on to each iron core, and the pole pieces, G<sup>3</sup>, substantially as described.

Eighth—The construction of the sole or bed plate of dynamo machines, with a gap through which a portion of the wheel descends into a pit below, substantially as described.

Ninth—The combination with the boss of the revolving wheel of loose iron collars pressed outwards from the boss by screw studs, to cause them to bear lightly against the sides of the bearings in which the axle of the wheel is carried, substantially as described.

Tenth—The combination of the bed plate, I, with the slot or gap, I<sup>1</sup>, therein, the fixed rings, M, bolted to the inside of the gap I<sup>1</sup>, the tie rods, M<sup>2</sup>, the low standards carrying the axis of the revolving wheel, and the struts from the top of the standards, substantially as described.

Eleventh—The construction of the fixed rings, M, which carry the induction bobbins each in three segments, one much smaller than either of the other two, substantially as and for the purpose hereinbefore described.

Twelfth—The construction of the cores of the fixed coils of T pieces with wedge shaped heads welded into V shaped pieces formed of iron plate bent to an acute angle, substantially as described.

Thirteenth—The alternative construction of the same cores with stud bolts instead of fixed stems, for convenience of removing the fixed coils, substantially as described.

Fourteenth

---

*Improvements in Dynamo-electric Machines.*

---

Fourteenth—The construction of the stationary iron rings of this or any other dynamo machine where one end of the iron core of each of the armature bobbins is attached to such a ring with a channeled section and a water service for the removal and recovery of the waste heat.

Fifteenth—The method of regulating separately excited dynamo machines by driving the exciter by a separate engine and bringing the stop valves of the small or of both engines into the photometer room substantially as described.

In witness whereof, I, the said James Edward Henry Gordon, have hereunto set my hand and seal, this twentieth day of October, 1882.

J. E. H. GORDON.

---

This is the specification marked "A" referred to in the annexed Letters of Registration granted to James Edward Henry Gordon, this 19th day of January, A.D. 1883.

AUGUSTUS LOFTUS.

---

**REPORT.**

---

Sir,

We do ourselves the honor to report, in reply to your blank cover communication of the 4th instant, No. 13,553, that we are of opinion that Letters of Registration may be granted in favour of James Edward Henry Gordon, for an invention entitled "Improvements in Dynamo-electric Machines" in terms of his petition, specification, drawings, and claim.

Sydney, 12 December, 1882.

We have, &c.,  
E. C. CRACKNELL.  
GOTHER K. MANN.

The Under Secretary of Justice.

---

[Drawings—two sheets.]

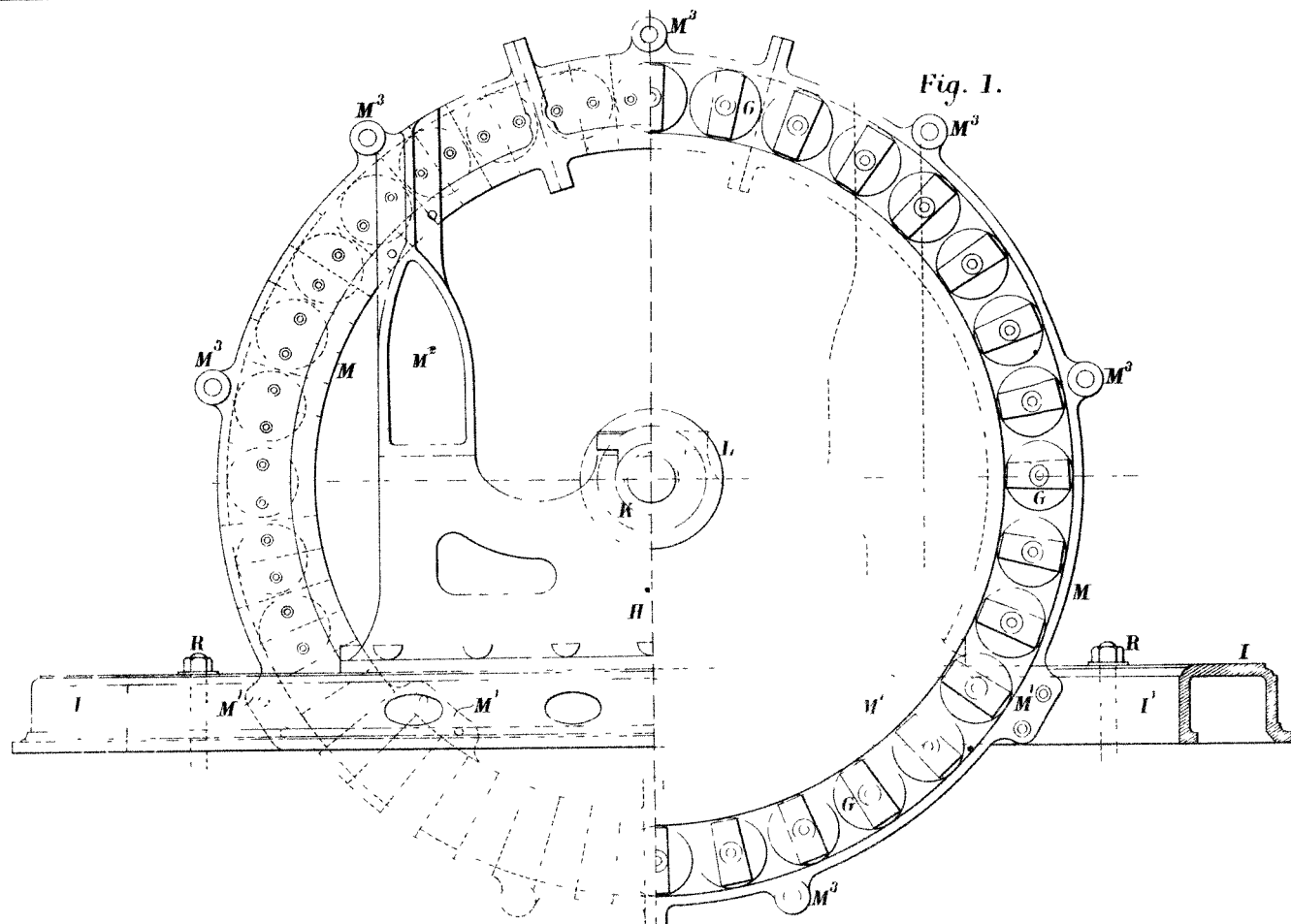


Fig. 1.

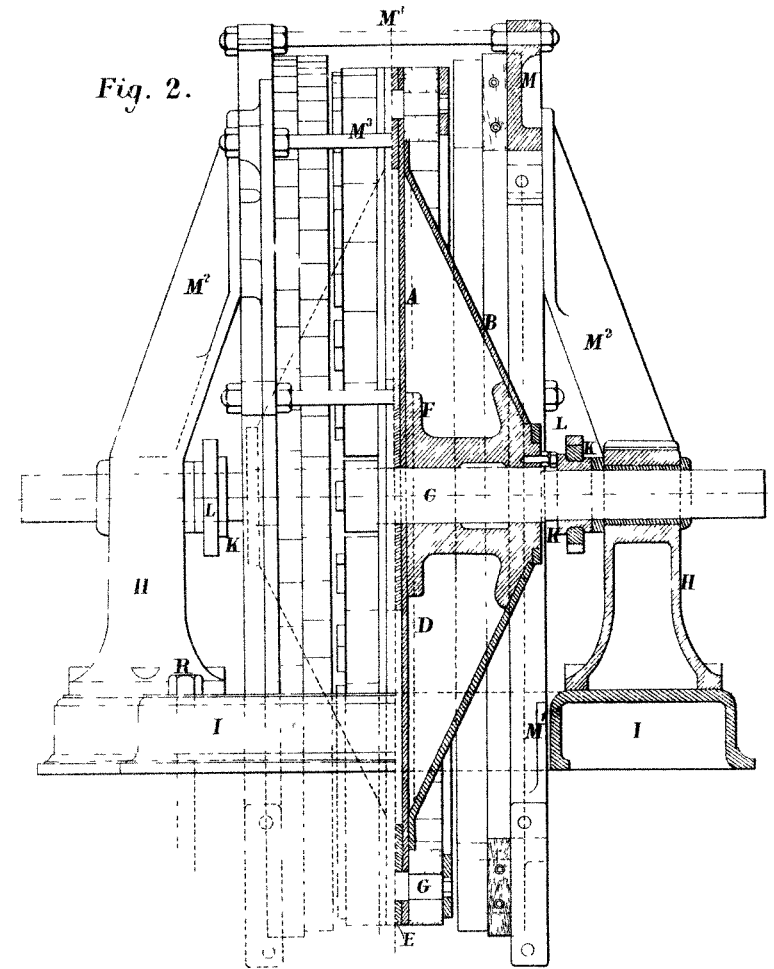


Fig. 2.

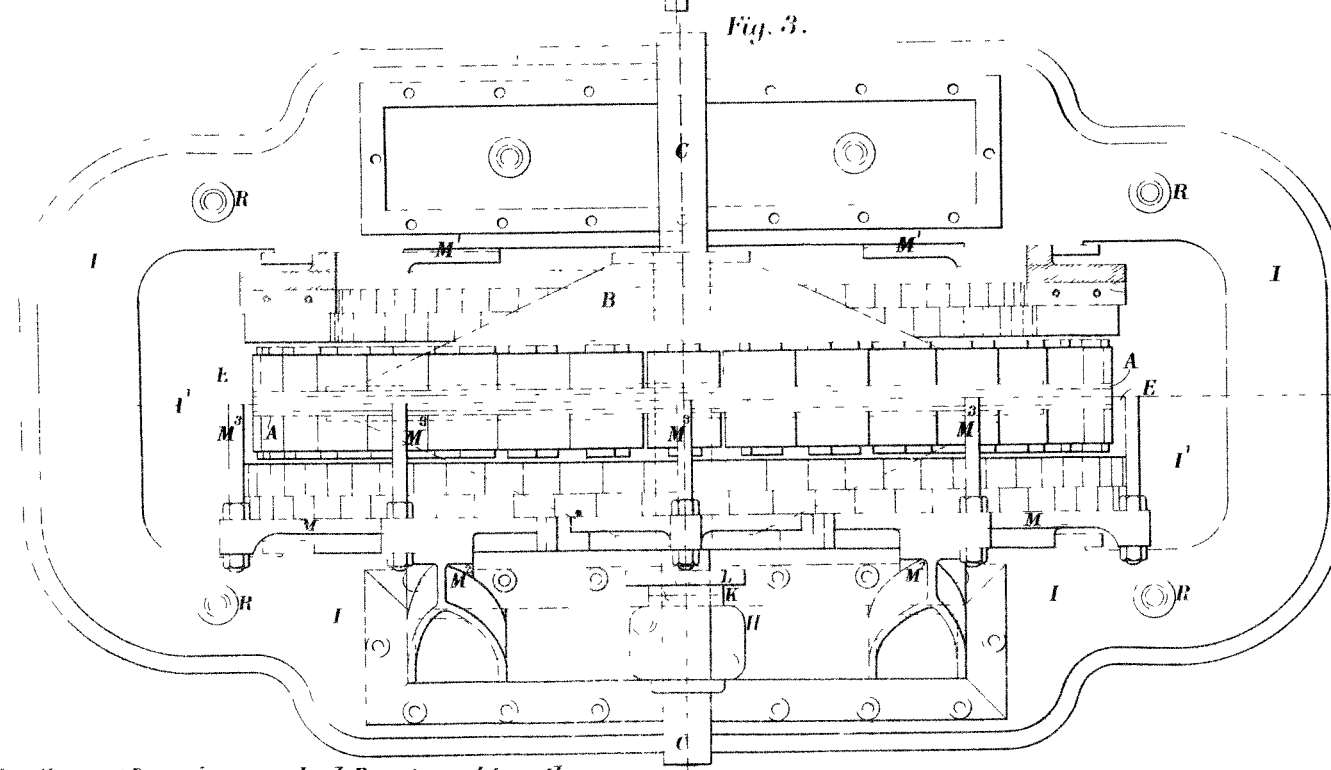


Fig. 3.

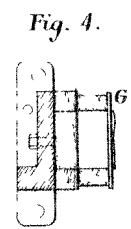


Fig. 4.

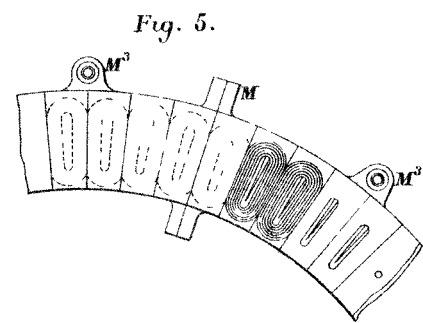


Fig. 5.

This is the Sheet of Drawings marked B. referred to in the annexed Letters of Registration granted to James Edward Henry Gordon, this nineteenth day of January, A D 1883.  
Augustus Loftus.

PHOTO-LITHOGRAPHED AT THE GOVT. PRINTING OFFICE SYDNEY, NEW SOUTH WALES.

Fig. 35.

Fig. 6.

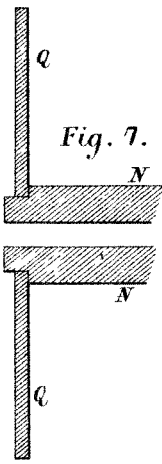
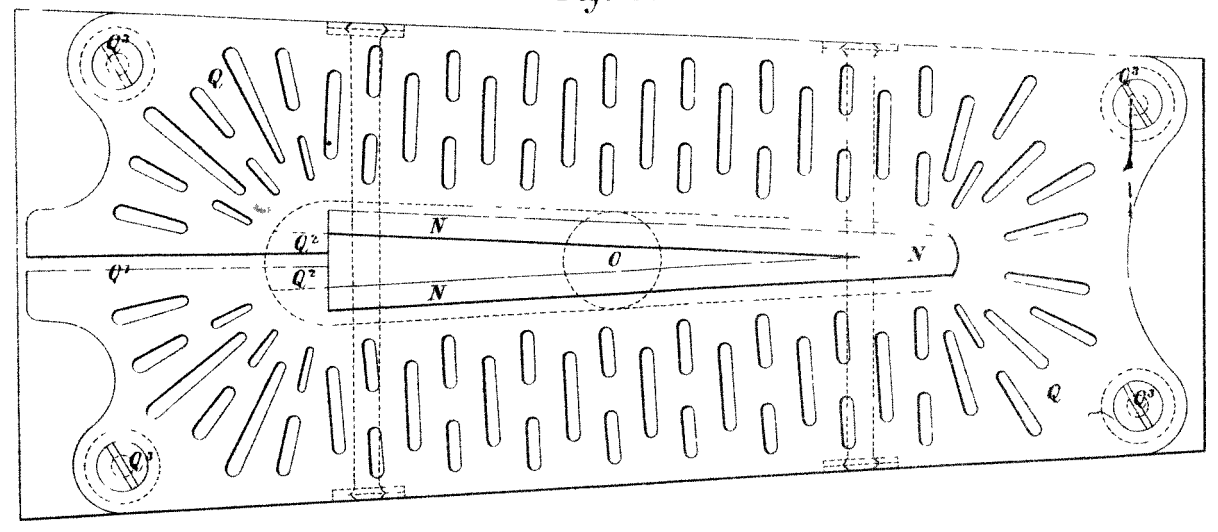


Fig. 8.

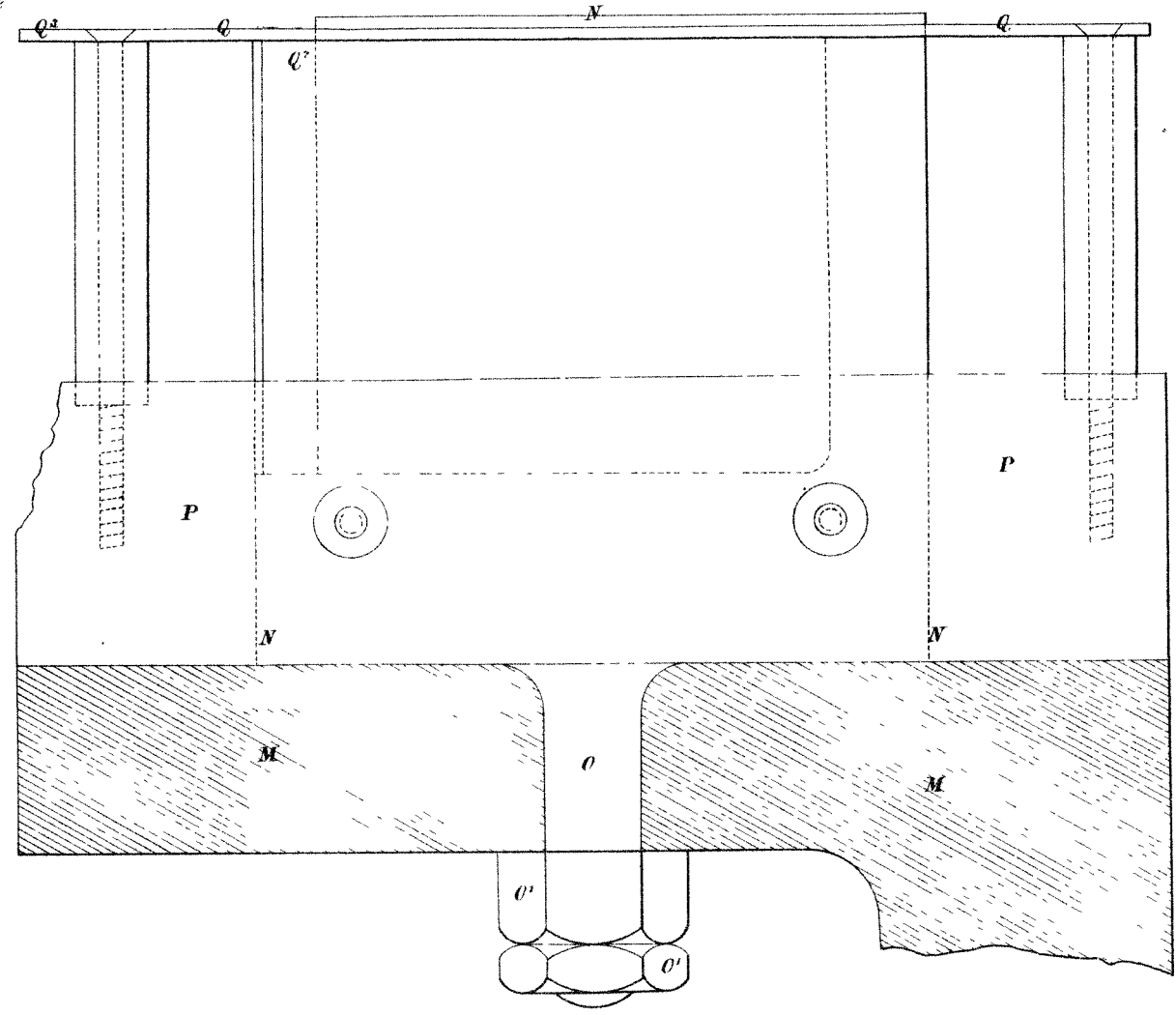


Fig. 10.

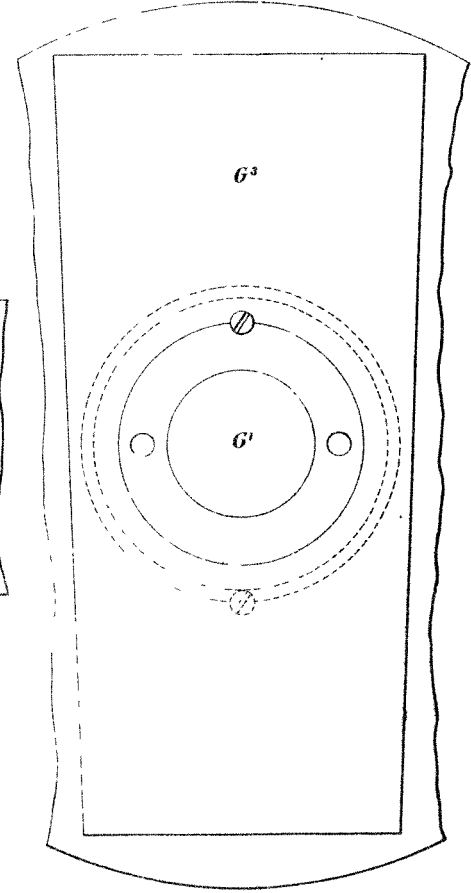
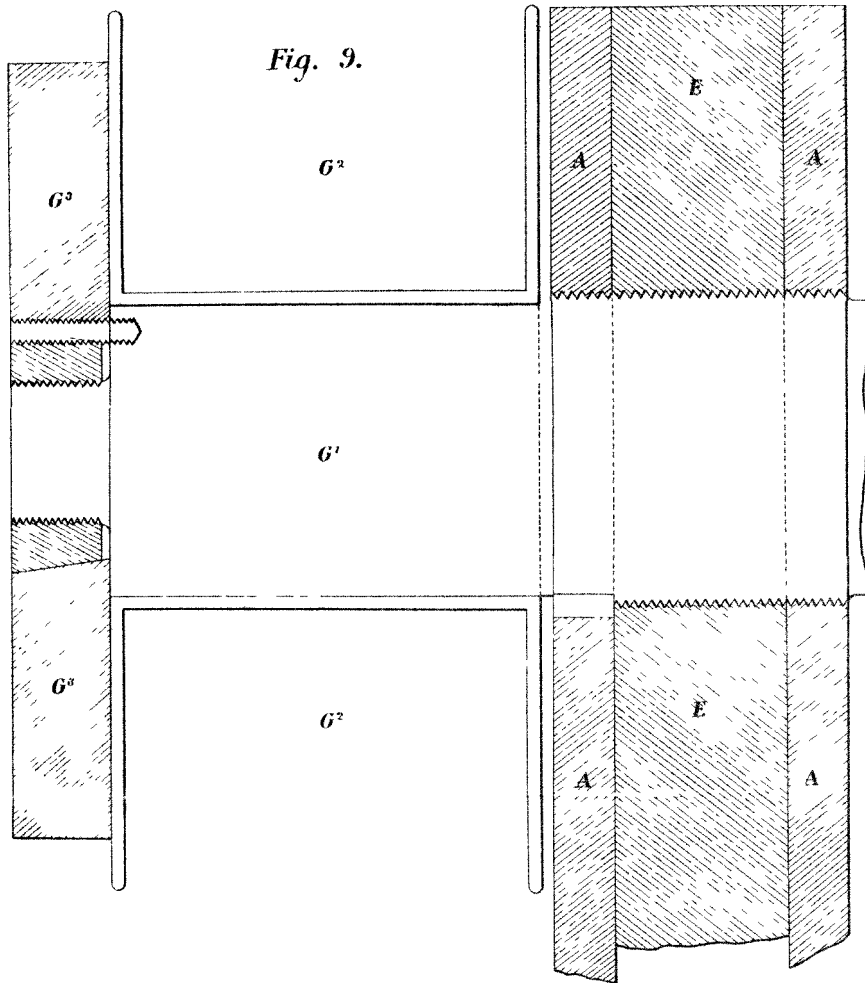


Fig. 9.



This is the Sheet of Drawings marked C. referred to in the annexed Letter of Registration granted to James Edward Henry Gordon, this nineteenth day of January, A. D. 1883.

Augustus Loftus.



A.D. 1883, 19th January. No. 1187.

FIRE INDICATOR AND ALARM.

LETTERS OF REGISTRATION to Edward Tatham, for an invention entitled  
"A Fire Indicator and Alarm."

[Registered on the 19th day of January, 1883, in pursuance of the Act 16 Vic. No. 24.]

BY HIS EXCELLENCY THE RIGHT HONORABLE SIR AUGUSTUS WILLIAM FREDERICK SPENCER LOFTUS (commonly called LORD AUGUSTUS LOFTUS), Knight Grand Cross of the Most Honorable Order of the Bath, a Member of Her Majesty's Most Honorable Privy Council, Governor and Commander-in-Chief of the Colony of New South Wales and its Dependencies.

TO ALL TO WHOM THESE PRESENTS SHALL COME, greeting :

WHEREAS EDWIN TATHAM, of Balmain, in the Colony of New South Wales, plumber, hath by his Petition humbly represented to me that he is the author or designer of a certain invention or improvement in manufactures, that is to say, of an invention entitled "A Fire Indicator and Alarm," which is more particularly described in the amended specification and the sheet of drawings which are hereunto annexed; and that he, the said Petitioner, had deposited with the Honorable the Treasurer of the said Colony of New South Wales the sum of Twenty Pounds sterling, for defraying the expense of granting these Letters of Registration, as required by the Act of Council, sixteenth Victoria, number twenty-four, and hath humbly prayed that I would be pleased to grant Letters of Registration whereby the exclusive enjoyment and advantage of the said invention or improvement might be secured to him for a period of fourteen years: And I, being willing to give encouragement to all inventions and improvements in the arts or manufactures which may be for the public good, and having received a report favourable to the prayer of the said Petition from competent persons appointed by me to examine and consider the matters stated therein and to report thereon for my information, am pleased, with the advice of the Executive Council, and in exercise of the power and authority given to me by the said Act of Council, to grant, and do by these Letters of Registration grant, unto the said Edwin Tatham, his executors, administrators, and assigns, the exclusive enjoyment and advantage of the said invention or improvement, for and during the term of fourteen years from the date hereof; to have, hold, and exercise unto the said Edwin Tatham, his executors, administrators, and assigns, the exclusive enjoyment and advantage thereof, for and during and unto the full end and term of fourteen years from the date of these presents next and immediately ensuing, and fully to be complete and ended: Provided always, that if the said Edwin Tatham shall not, within three days after the granting of these Letters of Registration, register the same in the proper office in the Supreme Court, at Sydney, in the said Colony of New South Wales, then these Letters of Registration, and all advantages whatsoever hereby granted, shall cease and become void.

In witness whereof, I have hereunto set my sign manual, and have caused the present Letters of Registration to be sealed with the seal of the said Colony of New South Wales, at Government House, Sydney, in New South Wales, this nineteenth day of January, in the year of our Lord one thousand eight hundred and eighty-three.

[L.S.]

AUGUSTUS LOFTUS.

*Fire Indicator and Alarm.*

SPECIFICATION of EDWIN TATHAM, of Balmain, in the Colony of New South Wales, for an invention for a "Fire Indicator and Alarm."

THIS invention has for its object the ringing of a bell, or otherwise giving an alarm or indication when the temperature of the building or apartment wherein it is placed is raised to a certain predetermined point. It is used in combination with an ordinary voltaic battery, and electric bell of comparatively small size; or in combination with an electro-magnet, arranged to release the detent of a spring, weight, or source of stored up power, to ring a bell of comparatively large dimensions. In the first case, the expansion of air or gases in a confined chamber, moves a piston, and so makes electrical contact between the terminals of a battery, and rings a bell in the ordinary and well-known way. In the second case, the completion of the circuit through an electro-magnet causes the magnet to attract the armature and withdraw the catch-pawl, detent, or ratchet, which restrains the spring or other source of power, when a bell of any required dimensions may be rung, or other alarm given. Referring to my drawings:—

Fig. 1 is one form of my invention.—A is an air-tight vessel. B is an air-tight collar on A. C is a curved tube or inverted syphon, having a liquid, as oil, water, glycerine, or other fluid, in the bend and partly up the two legs, such tube being fixed air-tight in A by collar B. D is a float supported on the surface of the fluid in C. E is a stem of vulcanite, wood, glass, or other non-conductor of electricity attached to D, and extending beyond the outer open end of C. F is a guide to keep E in position, and allow it freely to rise or fall. G is a metallic cup containing mercury or other clean metallic surface, to enable electrical contact to be made when it rises. H is a wire from the pole of an electrical battery. J is a wire forming the terminal of the opposite pole to H. K is a wire connecting J to the battery. L is a set screw by which J is fixed at the required height relative to G. M is a scale of temperatures, showing position of G when the air contained in A is raised to the several degrees marked upon the scale. The wire J being adjusted to the determined temperature when A reaches that temperature the pressure of air within is increased and presses on the surface of the fluid in the syphon C, raising it in the outer leg, and with it the float D, rod E, and contact-maker G, and closing the circuit between H and K.

In Fig. 2—A is a bulb or reservoir, preferably made of glass or metal. B is a stem to A. C is an inverted syphon containing mercury, made of glass or other non-conductor of electricity. D is a metal wire inserted in C, and in contact with the mercury piston, this wire being one terminal of a battery. E is a wire from the opposite pole of a battery to wire D. F is a set screw to adjust the height of the wire E in the outer stem C above the mercury. G is a scale of temperatures, showing the position of the surface of the mercury piston when the air contained in A is raised to the several degrees marked upon the scale. The wire F being adjusted to the determined temperature, when A reaches that temperature the air within expands and presses on the mercury, elevating it in the outer tube, and closing the circuit between D and E.

In Fig. 3—A is the bulb of my apparatus, containing the air or gas, to be expanded by increase of temperature. H is an electric or voltaic battery. J is an electric bell. KK are wires connecting the bell, the battery, and my apparatus. LL are ceiling joists. M is the ceiling of a room to which my apparatus is applied. N is an opening concealed by an ornament or otherwise, by which the heated air of the apartment reaches A. When the air of the building or apartment is raised by a fire, the air or gas contained in A is also heated and expanded, when it presses on the fluid piston, and so makes electrical contact between the terminals of a battery to give an alarm in the way before described.

Having now described my invention, it must be understood that I do not claim the several parts, which are well-known devices, nor the use of a mercurial thermometer, to give an alarm by means of an electric bell; but what I do claim is,—

First—The combination of an air-chamber and fluid-piston in an inverted syphon, in such a way that increase of temperature in the chamber, and consequent expansion of the contained air, will move the piston and make contact between the terminals of a battery, so as to ring an electric bell.

Secondly—The combination of an air-chamber and fluid-piston, as before described, with an alarm-bell rung by clock-work, an electro-magnet, having an armature which releases the clock-work, and a voltaic battery to excite the electro-magnet, substantially as described.

In witness whereof, I, the said Edwin Tatham, have hereby set my hand and seal, this thirteenth day of October, eighteen hundred and eighty-two.

EDWIN TATHAM.

This is the amended specification referred to in the annexed Letters of Registration granted to Edwin Tatham, this nineteenth day of January, A.D. 1883.

AUGUSTUS LOFTUS.

### REPORTS.

Sir,

We do ourselves the honor to report, in reply to your blank cover communication of the 4th instant, No. 11,551, that on examination of Mr. Edwin Tatham's specification, drawings, and claim, we find that the said invention "of a Fire Indicator, worked by an adjustable Thermometer," is already in use, and has been so for some years. We, therefore, are unable to recommend its registration in favour of Mr. Tatham.

We have, &c.,

E. C. CRACKNELL.  
GOTHER K. MANN.

The Under Secretary of Justice.

Sydney, 11 October, 1882.

Sir,

We do ourselves the honor to state that we are of opinion the claim of Mr. Edwin Tatham, for his registration of an invention of a "Fire Indicator and Alarm" may now be granted, in terms of his revised specification, drawings, and claim, transmitted for our report under your blank cover communication, 21st November, No. 13,191.

We have, &c.,

E. C. CRACKNELL.  
GOTHER K. MANN.

The Under Secretary of Justice.

Sydney, 1 December, 1882.

[Drawings—one sheet.]

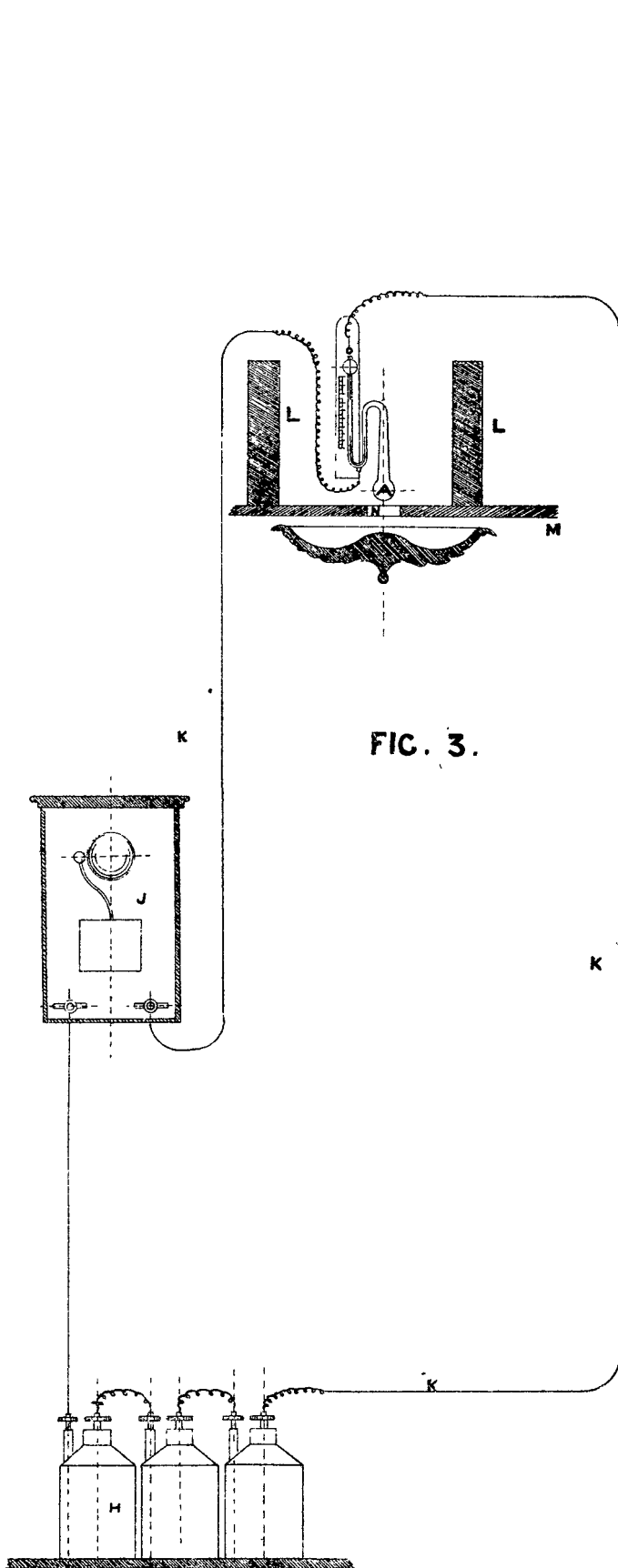


FIG. 3.

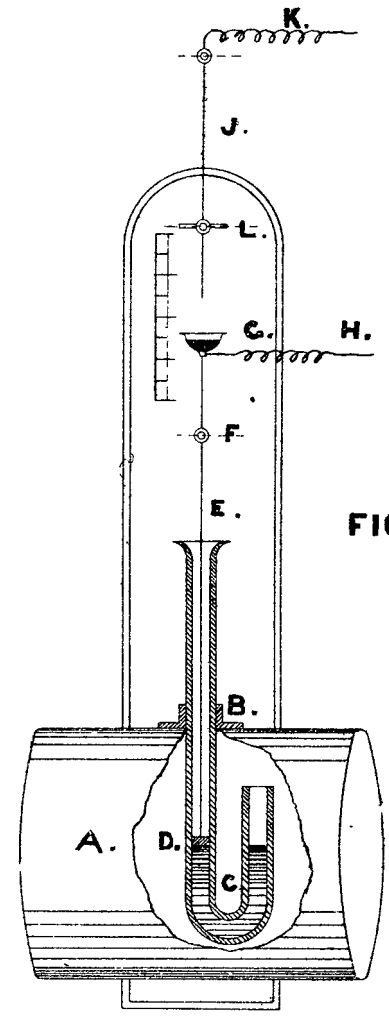


FIG. 1.

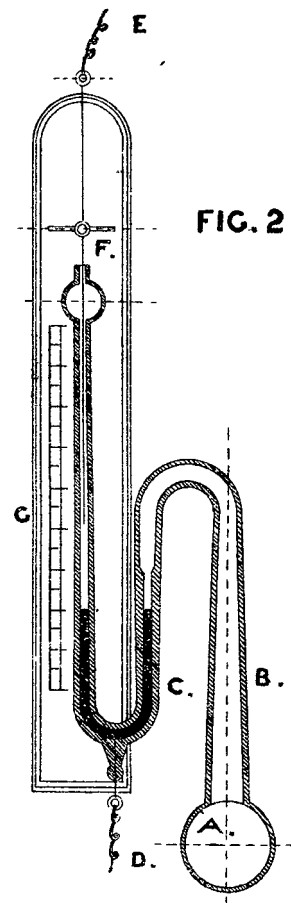


FIG. 2.

*This is the Sheet of Drawings referred to in the annexed Letters of Registration granted to Edwin Tatham, this nineteenth day of January A.D. 1883*

*Augustus Loftus.*





A.D. 1883, 19th *January*. No. 1188.

**IMPROVEMENTS IN MEANS FOR RAISING SUNKEN VESSELS.**

**LETTERS OF REGISTRATION to Edwin Tatham, John Tatham, and Charles Shepherd, for Improvements in means for Raising Sunken Vessels.**

[Registered on the 19th day of January, 1883, in pursuance of the Act 16 Vic. No. 24.]

BY HIS EXCELLENCY THE RIGHT HONORABLE SIR AUGUSTUS WILLIAM FREDERICK SPENCER LOFTUS (commonly called LORD AUGUSTUS LOFTUS), Knight Grand Cross of the Most Honorable Order of the Bath, a Member of Her Majesty's Most Honorable Privy Council, Governor and Commander-in-Chief of the Colony of New South Wales and its Dependencies.

TO ALL TO WHOM THESE PRESENTS SHALL COME, greeting:

WHEREAS EDWIN TATHAM and JOHN TATHAM, both of Balmain, near Sydney, in the Colony of New South Wales, plumbers, and CHARLES SHEPHERD, of Sydney aforesaid, civil engineer, have by their Petition humbly represented to me that the said Edwin Tatham is the author or designer of a certain invention or improvement in manufactures, that is to say, of an invention entitled "Improvements in means for Raising Sunken Vessels," which is more particularly described in the specification and the sheet of drawings which are hereunto annexed; and that they, the said Petitioners, are the assignees of the said Edwin Tatham of and in the said invention; and that they, the said Petitioners, have deposited with the Honorable the Treasurer of the said Colony of New South Wales the sum of Twenty Pounds sterling, for defraying the expense of granting these Letters of Registration, as required by the Act of Council, sixteenth Victoria, number twenty-four; and have humbly prayed that I would be pleased to grant Letters of Registration, whereby the exclusive enjoyment and advantage of the said invention or improvement might be secured to them for a period of fourteen years: And I, being willing to give encouragement to all inventions and improvements in the arts or manufactures which may be for the public good, and having received a report favourable to the prayer of the said Petition, from competent persons appointed by me to examine and consider the matters stated therein and to report thereon for my information, am pleased, with the advice of the Executive Council, and in exercise of the power and authority given to me by the said Act of Council, to grant, and do by these Letters of Registration grant unto the said Edwin Tatham, John Tatham, and Charles Shepherd, their executors, administrators, and assigns, the exclusive enjoyment and advantage of the said invention or improvement for and during the term of fourteen years from the date hereof; to have, hold, and exercise unto the said Edwin Tatham, John Tatham, and Charles Shepherd, their executors, administrators, and assigns the exclusive enjoyment and advantage thereof for and during and unto the full end and term of fourteen years from the date of these presents next and immediately ensuing, and fully to be complete and ended: Provided always, that if the said Edwin Tatham, John Tatham, and Charles Shepherd, shall not, within three days after the granting of these Letters of Registration, register the same in the proper office in the Supreme Court, at Sydney, in the said Colony of New South Wales, then these Letters of Registration, and all advantages whatsoever hereby granted, shall cease and become void.

In witness whereof, I have hereunto set my sign manual, and have caused the present Letters of Registration to be sealed with the seal of the said Colony of New South Wales, at Government House, Sydney, in New South Wales, this nineteenth day of January, in the year of our Lord one thousand eight hundred and eighty-three.

[L.S.]

AUGUSTUS LOFTUS.

---

*Improvements in means for Raising Sunken Vessels.*

---

SPECIFICATION of EDWIN TATHAM, of Balmain, near Sydney, in the Colony of New South Wales, for an invention entitled "Improvements in means for Raising Sunken Vessels."

Our improvements in means for raising sunken vessels consist, first, in making such vessels air-tight except at one point, and filling them with hydrogen gas, generated by mixing acids, such as sulphuric acid, with zinc, or other material, which may be used with such acids for decomposing water; and secondly, in the particular form of apparatus we use therefor, which consists of a chamber, preferably a common 400-gallon malt tank, into which we insert two pipes, one reaching nearly to the bottom from above the surface of the water, and the other inserted (say) 6 inches in it, and reaching as high as possible in the sunken vessel.

But in order that our invention may be more clearly understood, we will now refer to the drawing herewith, in which figure 1 shows a longitudinal section of a sunken ship in which our apparatus is generating hydrogen gas, and discharging the water over the deck; figure 2, a similar view (discharging through a hole in the side); and figure 3, the same vessel with the gas-generating apparatus outside. A is the tank, B the acid feed-pipe, C the gas exit pipe, and D the water discharge pipe or opening.

To raise a sunken vessel we first make it air-tight, and then sink as many such tanks, A, filled with zinc as are required (one would do, but it would have to be refilled with zinc whenever all such becomes sulphate of zinc), either in the hold or at the side of the vessel. Then at intervals we pour down pipe B, a small quantity of sulphuric acid, which sinks to the bottom, and acting upon the zinc decomposes the water and generates hydrogen gas; such gas, passing through pipe C, fills the vessel, and forces out the water through pipe or hole D, and the vessel will rise until that opening is above the surface.

Having thus described our invention, and the manner of performing same, we would have it understood that we do not claim generating hydrogen gas by the admixture of sulphuric acid, zinc, and water, nor do we confine ourselves to the precise manner of carrying our invention into effect, so long as the nature and principle thereof be retained, but what we do claim as our invention is—

First—Raising sunken vessels by filling them with hydrogen gas generated by pouring acids, such as sulphuric acid, upon zinc (or other material which may be used with such acids for decomposing water) in a tank under water.

Second—The combination with an air-tight sunken vessel having opening, D, of the tank, A, having pipes, B and C, in the manner and for the purposes substantially as herein described and explained.

In witness whereof, I, the said Edwin Tatham, have hereto set my hand and seal, this twentieth day of November, one thousand eight hundred and eighty-two.

Witness—

FRED. WALSH,

Manager, Edwd. Waters, Patent Office, Sydney.

EDWIN TATHAM.

This is the specification referred to in the annexed Letters of Registration granted to Edwin Tatham, John Tatham, and Charles Shepherd, this nineteenth day of January, A.D. 1883.

AUGUSTUS LOFTUS.

---

**REPORT.**

---

Sir,

In reply to your communication of the 22nd ultimo, we have the honor to report that we have examined Messrs. Tatham, Shepherd, and Tatham's application for Letters of Registration for "Improvements in means for Raising Sunken Vessels," together with specification, &c., and see no reason why that application should not be granted.

We have, &c.,

FRANCIS HIXSON.  
H. BRODERICK.

The Under Secretary of Justice.

---

[Drawings—one sheet.]

## TATHAMS PATENT.

Fig. 1.

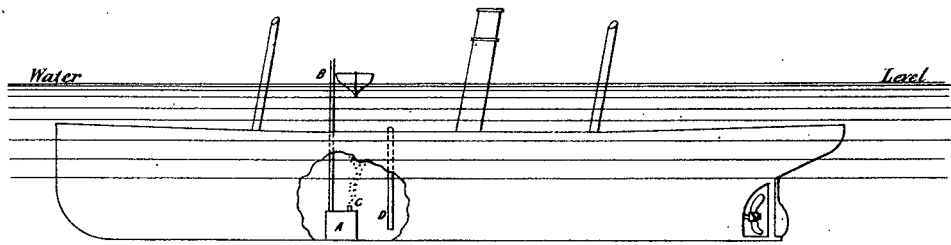


Fig. 2.

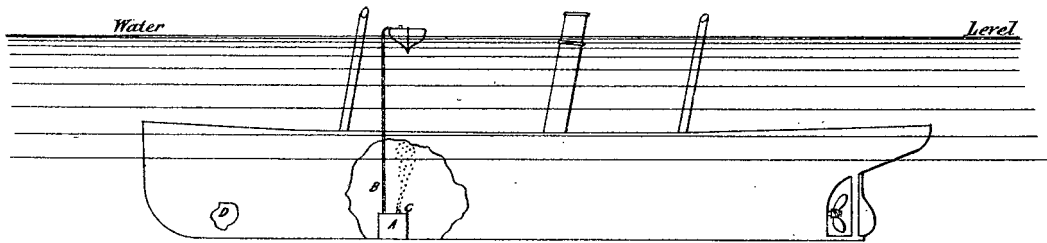
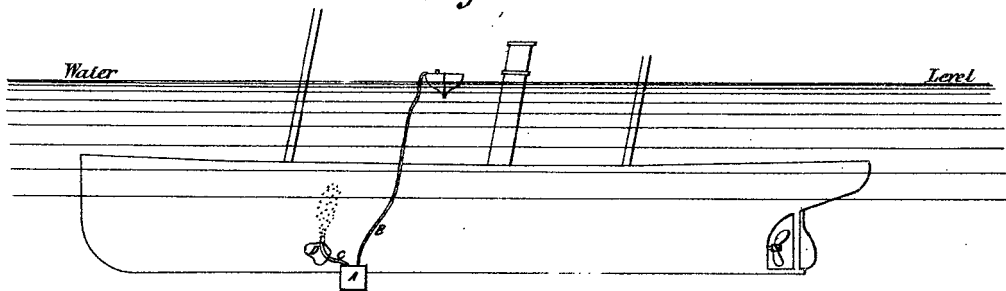
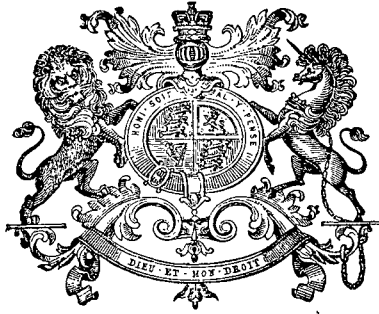


Fig. 3.



*This is the Sheet of Drawings referred to in the annexed  
Letters of Registration granted to Edwin Tatham, John  
Tatham, and Charles Shepherd, this 19<sup>th</sup> day of January  
A.D. 1883.*

*Augustus Loftus.*




---

A.D. 1883, 19th *January*. No. 1189.

---

AN IMPROVED METHOD OF, AND MEANS OR APPARATUS FOR, EXTRACTING GOLD AND SILVER FROM THEIR ORES BY THE COMBINED ACTION OF ELECTRICITY AND MERCURY.

LETTERS OF REGISTRATION to Richard Barker for an Improved Method of, and Means or Apparatus for, Extracting Gold or Silver from their Ores by the combined action of Electricity and Mercury.

[Registered on the 19th day of January, 1883, in pursuance of the Act 16 Vic. No. 24.]

---

BY HIS EXCELLENCY THE RIGHT HONORABLE SIR AUGUSTUS WILLIAM FREDERICK SPENCER LOFTUS (commonly called LORD AUGUSTUS LOFTUS), Knight Grand Cross of the Most Honorable Order of the Bath, a Member of Her Majesty's Most Honorable Privy Council, Governor and Commander-in-Chief of the Colony of New South Wales and its Dependencies.

TO ALL TO WHOM THESE PRESENTS SHALL COME, greeting :

WHEREAS RICHARD BARKER, of London, England, mining engineer, hath by his Petition humbly represented to me that he is the author or designer of a certain invention or improvement in manufactures, that is to say, of an invention entitled "An improved method of, and means or apparatus for, extracting Gold and Silver from their Ores by the combined action of electricity and mercury," which is more particularly described in the specification and the sheet of drawings which are hereunto annexed ; and that he, the said Petitioner, hath deposited with the Honorable the Treasurer of the said Colony of New South Wales the sum of Twenty Pounds sterling for defraying the expense of granting these Letters of Registration, as required by the Act of Council, sixteenth Victoria, number twenty-four, and hath humbly prayed that I would be pleased to grant Letters of Registration whereby the exclusive enjoyment and advantage of the said invention or improvement might be secured to him for a period of fourteen years : And I, being willing to give encouragement to all inventions and improvements in the arts or manufactures which may be for the public good, and having received a report favourable to the prayer of the said Petition from competent persons appointed by me to examine and consider the matters stated therein and to report thereon for my information, am pleased, with the advice of the Executive Council, and in exercise of the power and authority given to me by the said Act of Council, to grant, and do by these Letters of Registration grant unto the said Richard Barker, his executors, administrators, and assigns, the exclusive enjoyment and advantage of the said invention or improvement, for and during the term of fourteen years from the date hereof ; to have, hold, and exercise unto the said Richard Barker, his executors, administrators, and assigns, the exclusive enjoyment and advantage thereof for and during and unto the full end and term of fourteen years from the date of these presents next and immediately ensuing, and fully to be complete and ended : Provided always, that if the said Richard Barker shall not, within three days after the granting of these Letters of Registration, register the same in the proper office in the Supreme Court, at Sydney, in the said Colony of New South Wales, then these Letters of Registration, and all advantages whatsoever hereby granted, shall cease and become void.

In witness whereof, I have hereunto set my sign manual, and have caused the present Letters of Registration to be sealed with the seal of the said Colony of New South Wales, at Government House, Sydney, in New South Wales, this nineteenth day of January, in the year of our Lord one thousand eight hundred and eighty-three.

[L.S.]

AUGUSTUS LOFTUS.

*Apparatus for Extracting Gold and Silver from their Ores, &c.*

SPECIFICATION of RICHARD BARKER, of London, in England, mining engineer, for an invention entitled "An improved method of, and means or apparatus for, extracting Gold and Silver from their Ores by the combined action of electricity and mercury."

MY invention relates to an improved method of, and means or apparatus for, extracting gold and silver from their ores by the combined action of electricity and mercury, applied in the manner as is hereinafter described. For the purpose of my invention I provide a table, insulated or not, in which I place two or more riffles, or baths, containing mercury, at convenient distances from one another, and fitted, or not, with the ordinary agitators. Over this table the quartz, alluvial deposit, or other matter containing gold, silver, or both these metals, is washed by the ordinary method. A current of electricity is then passed through the apparatus, as hereinafter shown, by one or more suitable conductors, in the following manner:—The negative pole (or cathode) of the battery, or other source of electricity, is connected with the mercury in the riffles, and the positive pole (or anode) is introduced into the water immediately above the mercury, and sufficiently close to it to cause an energetic action, the electric current being allowed to pass through the water by placing in it, at convenient distances, plates or wires of copper, or other good conductors of electricity. It is necessary to keep the mercury covered with a stratum of water, as the action of the mercury is thereby properly maintained. The introduction of an electric current into the water, as above specified, causes continual agitation at the surface of the mercury, prevents it from what is technically termed "sickening" in the presence of arsenic, sulphur, oil, or any other substances known to act in like manner, and which are deleterious to the action of mercury in amalgamating with gold or silver, and also prevents titanic sand or other heavy mineral deposits from remaining on the surface. The surface of the mercury immediately under and around the copper plates, wires, or the like, is kept thoroughly bright and capable of amalgamating readily with gold and silver, despite the presence of foreign substances. The conducting plates, wires, or the like, I make either stationary or movable, and attached to the riffles, taking care, however, that if revolving or otherwise in motion the plates or wires shall never come into contact with the mercury.

And in order that my invention may be readily understood and carried into effect by any competent person experienced in the art or process to which it relates, I proceed to describe the same with reference to the accompanying drawings.

Figure 1 is a longitudinal elevation, and figure 2 a plan of my improved electro-amalgamator; figures 3 and 4 details of certain parts.

A is the riffle table, in which are formed the riffles *a a a*; this table and the riffles may be made in one piece or otherwise, as may be most convenient.

The material I prefer to employ in the construction of my riffle table and riffles is wood, but iron, porcelain, earthenware (glazed or unglazed), or any combination of the above-mentioned materials may be employed.

The number of riffles in a table depends upon the nature of the ore to be treated; where the ore is refractory ten riffles (as shown) or more may be required.

In the first series three riffles are shown, each one provided with combined revolving mechanical stirrers and revolving electrodes (anodes), B. Each set of stirrers consists of a shaft, *b*, to which are attached arms or pins, *b*<sup>1</sup>, which act as the stirrers, and a second set of arms or pins, *b*<sup>2</sup>, which act as the electrodes. These shafts are kept in constant contact with the main current of electricity, by means of any suitable connection. The mechanical stirrers are designedly longer than the electrodes, the object in making the electrodes shorter than the stirrers is to prevent them from coming into contact with the mercury, which would otherwise destroy the whole operation.

In the second series the stirrers are the same as described in the first series, but instead of the electric current being supplied along the shaft it is conveyed by wires or plates, *c*, which are laid across the riffle (as seen in plan, figure 2) a little above the mercury, special care being taken that they shall not come into contact with the mercury.

In the third series the mechanical stirrers are dispensed with, but the current is rendered intermittent by means of a special construction of revolving electrode, B<sup>1</sup>, and is supplied along the shaft as in the first series, but in such a manner that when the arms or pins are perpendicular, as in figure 1, the current is caused to flow, and when horizontal the current is interrupted. This special construction of revolving electrode is clearly shown in detailed view, and on a larger scale, in figure 3.

In both the first and the third series I establish the electric connection by strips, *d*, and bands, *d*<sup>1</sup>, of metal arranged on the surface of the shaft, as clearly shown in detailed view, figure 4; or by a metallic core in contact with the inner ends of the electrodes.

The shafts are made of wood, the stirrers of any suitable non-conducting material, and the electrodes (anodes) of brass or any other hard and durable metal. The shafts may also be made of metal, and where metal is used the shafts would be insulated in the usual way.

In the fourth series I dispense with the shafts and stirrers, and in this instance the electrodes are carried across the riffles, either as shown in the ninth riffle, in figure 2, or interlaced, as shown in the tenth riffle.

In all cases care must be taken that the electrodes (anodes) shall never come into contact with the mercury (cathodes).

Each riffle is provided at bottom with a tap or cock, *e*, by means of which the mercury may be drawn off. Or the conducting wire may be passed through the heads of the plugs of the taps or cocks, and when desired to run off the mercury this wire must be disconnected and removed.

The electric current is supplied direct to one end of the first riffle, and passing through the mercury is then conveyed or led out by the wire L to the adjoining riffle, and so on to the whole series of riffles, as shown in full lines and dotted lines in figure 2.

The return current to the electric generator in the first and third series is conveyed by depressing screws, suitably placed for the purpose, on the side of the riffle table, and in immediate proximity to the shafts, so as to come into contact with the metallic bands, *d*<sup>1</sup>, but in the second and fourth series by the bars, *f f*.

*Apparatus for Extracting Gold and Silver from their Ores, &c.*

At that side of the riffle table opposite to the discharge taps or cocks each shaft carries a pulley, C, for the purpose of revolving the same, and the pulleys may be driven by any suitable gearing.

The most suitable speed for the shafts is forty-five revolutions per minute.

Mercury is supplied to each riffle in the manner employed in the ordinary amalgamation, and in my invention discharges the duty of a cathode in each riffle.

The ore is supplied to the platform D in the usual way. The table A is placed at a suitable inclination, and a current of water is applied in such a manner that the ore is caused to travel down the table and pass through each of the riffles between the several sets of electrodes (cathodes and anodes).

The electric action upon the surface of the mercury keeps the titanitic sand, &c., in a constant state of agitation, thereby ensuring perfect contact between the mercury and the particles of gold and silver, which would otherwise be lost, as the titanitic sand, &c., would form a layer upon the surface of the mercury, and so cause imperfect amalgamation, with a consequent loss of gold or of silver.

Having now described my invention, I claim and desire to secure by Letters Patent—

First—The improved method of extracting gold and silver from their ores, by the combined action of electricity and mercury, substantially as herein described.

Second—The construction or use of apparatus, such as is herein described, for the purpose of extracting gold and silver from their ores in the manner above indicated.

Third—The combination, substantially as described and shown, of the riffles with the various mechanical and electrical appliances, for the purposes specified, as hereinbefore mentioned and illustrated in the drawings annexed.

Fourth—The construction or use of revolving electrodes (anodes), as described and as shown in the drawings, for the purposes herein specified.

In witness whereof, I, the said Richard Barker, have hereunto set my hand and seal, this twentieth day of October, in the year 1882.

RICHARD BARKER.

This is the specification referred to in the annexed Letters of Registration granted to Richard Barker, this nineteenth day of January, A.D. 1883.

AUGUSTUS LOFTUS.

---

REPORT.

Sir,

We do ourselves the honor to report, in reply to your blank cover communication, 4th December, No. 13,555, that we are of opinion Letters of Registration may be granted in favour of Mr. Richard Barker, for an invention entitled "An improved method of, and means or apparatus for, extracting Gold and Silver from their Ores by the combined action of electricity and mercury," in terms of his specification, petition, drawings, and claim.

We have, &c.,

E. C. CRACKNELL.  
GOTHER K. MANN.

The Under Secretary of Justice.

---

[Drawings—one sheet.]

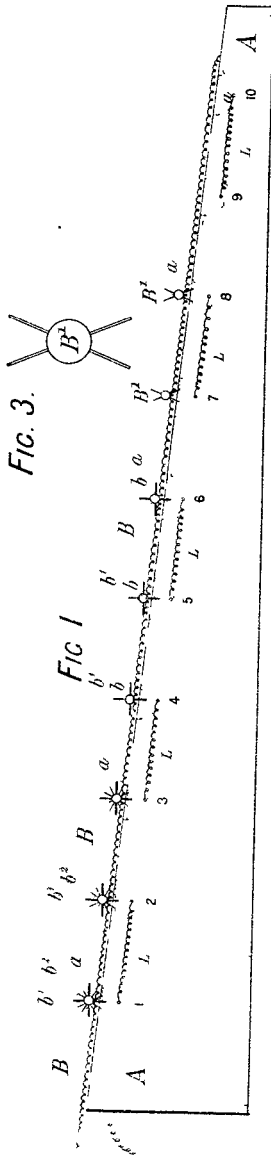


FIG. 3.

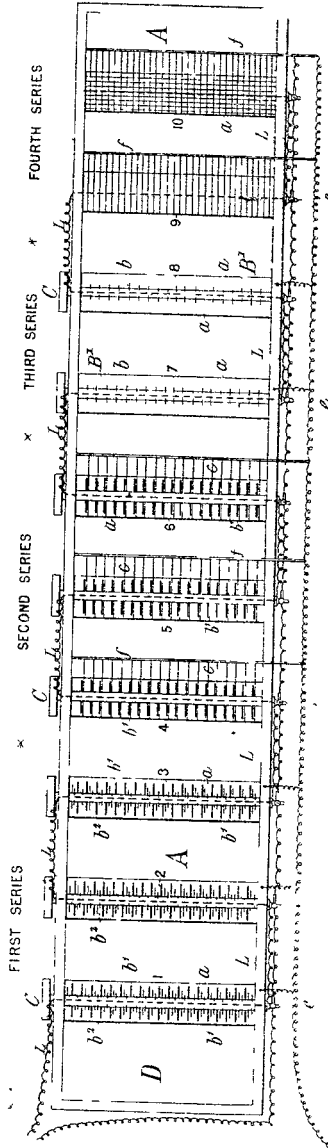
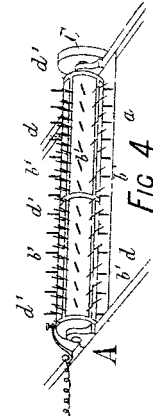
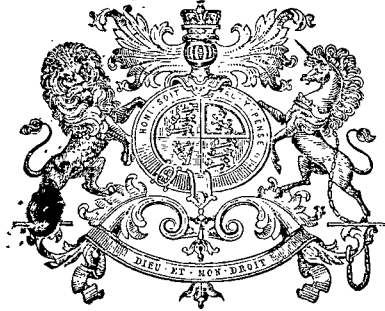


FIG 2



This is the Sheet of Drawings referred to in the annexed Letters of Reinstatement granted to Richard Barker this nineteenth day of January A.D 1883.

Augustus Iofcus.



A.D. 1883, 19th January. No. 1190.

IMPROVEMENT IN THE MANUFACTURE OF SPRING MATTRESSES, COUCHES,  
AND CHAIRS.

LETTERS OF REGISTRATION to Arthur Albert Bushell, for Improvement in  
the Manufacture of Spring Mattresses, Couches, and Chairs.

[Registered on the 19th day of January, 1883, in pursuance of the Act 16 Vic. No. 24.]

BY HIS EXCELLENCY THE RIGHT HONORABLE SIR AUGUSTUS WILLIAM FREDERICK SPENCER LOFTUS  
(commonly called LORD AUGUSTUS LOFTUS), Knight Grand Cross of the Most Honorable Order of  
the Bath, a Member of Her Majesty's Most Honorable Privy Council, Governor and Commander-in-  
Chief of the Colony of New South Wales and its Dependencies.

TO ALL TO WHOM THESE PRESENTS SHALL COME, greeting :

WHEREAS ARTHUR ALBERT BUSHELL, of Brisbane, in the Colony of Queensland, cabinet maker, hath by his Petition humbly represented to me that he is the author or designer of a certain invention or improvement in manufactures, that is to say, of an invention entitled "Improvement in the manufacture of Spring Mattresses, Couches, and Chairs," which is more particularly described in the specification and the sheet of drawings which are hereunto annexed ; and that he, the said Petitioner, hath deposited with the Honorable the Treasurer of the said Colony of New South Wales the sum of Twenty Pounds sterling, for defraying the expense of granting these Letters of Registration, as required by the Act of Council, sixteenth Victoria, number twenty-four ; and hath humbly prayed that I would be pleased to grant Letters of Registration, whereby the exclusive enjoyment and advantage of the said invention or improvement might be secured to him for a period of fourteen years : And I, being willing to give encouragement to all inventions and improvements in the arts or manufactures which may be for the public good, and having received a report favourable to the prayer of the said Petition, from competent persons appointed by me to examine and consider the matters stated therein and to report thereon for my information, am pleased, with the advice of the Executive Council, and in exercise of the power and authority given to me by the said Act of Council, to grant, and do by these Letters of Registration grant unto the said Arthur Albert Bushell, his executors, administrators, and assigns, the exclusive enjoyment and advantage of the said invention or improvement, for and during the term of fourteen years from the date hereof ; to have, hold, and exercise unto the said Arthur Albert Bushell, his executors, administrators, and assigns, the exclusive enjoyment and advantage thereof, for and during and unto the full end and term of fourteen years from the date of these presents next and immediately ensuing, and fully to be complete and ended : Provided always, that if the said Arthur Albert Bushell shall not, within three days after the granting of these Letters of Registration, register the same in the proper office in the Supreme Court, at Sydney, in the said Colony of New South Wales, then these Letters of Registration, and all advantages whatsoever hereby granted, shall cease and become void.

In witness whereof, I have hereunto set my sign manual, and have caused the present Letters of Registration to be sealed with the seal of the said Colony of New South Wales, at Government House, Sydney, in New South Wales, this nineteenth day of January, in the year of our Lord one thousand eight hundred and eighty-three.

[L.S.]

AUGUSTUS LOFTUS.



---

*Improvement in Manufacture of Spring Mattresses, Couches, and Chairs.*

---

SPECIFICATION AND DESCRIPTION.

I, ARTHUR ALBERT BUSHELL, of Edward-street, in the City of Brisbane, in the Colony of Queensland, cabinet maker, do hereby declare the nature of my invention for improvements in the manufacture of Spring Mattresses, Couches, and Chairs, in which springs may be used.

THIS invention relates to an improved method of fixing springs in mattresses, couches, and chairs, by which the springs are, through a simple mechanical arrangement, made almost self-supporting. Spring mattresses are now generally made in a case or box, with a stout wooden framework having boards fixed across the bottom at equal distances apart, the top being composed of canvas or other similar material supported by the springs. These springs are usually fastened inside such framework upon the cross-boards. The outer row of springs is fastened to the sides of the framework, for the purpose of preventing the springs from being drawn out of perpendicular, and the mattress losing its elasticity when a weight rested on it. One of the greatest objections to such mattresses is their very great weight, caused by the strong wooden frame, as it requires three or four men to move them. In spring mattresses a metal framework or rod has been sometimes fixed to serve the same purposes as the wooden frame; but to all the objection of clumsiness and unwieldiness applies. Another objection to such mattresses is that the hard sides of the box or framework are liable to do injury to persons using them.

By my invention the objections above stated to the present style of spring mattresses are entirely obviated. I use no framework at the sides or ends. The mattress, as invented by me, can be easily moved about by one person, and is not more inconvenient than the common palliase as regards weight. The springs round the sides are fastened by a simple contrivance hereunder described, which enables a person to rest or sit on them with ease and comfort.

In the application of my invention I use a light frame of laths or boards. I fasten the springs, which are marked "S," at each end of the laths or boards, which are marked "L," and at the necessary intervals along the laths or boards, as shown in diagram "A."

The ordinary mattress-springs are of a peculiar shape, being spiral, but broader at the top and bottom than in the middle. When the bottom of the outer row of springs has been fastened to the laths or boards all round, I attach one end of double piece of webbing, marked "W" on plan, or any other material of sufficient strength, to one of the coils about the middle of the spring, or any other portion of its height that I may think advisable, and fasten the other end of the webbing or other material to the end or edge of the lath or board tightly, and in such a manner as to draw the upper portion of the spring outwards, or to let it remain in its natural or any other position I may desire, according to circumstances. This causes the spring to offer a firm but elastic resistance to any weight resting on the inner portion of the mattress, and to recover its perpendicular position immediately the weight is removed. Several similar attachments may at times be required to be used, as, for instance, at the springs at the corners of the mattress.

The tops of the springs are connected with each other transversely and diagonally in the usual way, the tops of the outer row of springs being drawn inwards to a nearly perpendicular position when the canvas or other covering is being put on.

The attachment of the middle of the spring to the ends or edges of the laths or boards in the manner described gives an equally elastic surface to all the springs, and they cannot be thrown out of their proper place.

ARTHUR ALBERT BUSHELL,  
By his Attorney,  
F. B. FREEHILL.

This is the specification referred to in the annexed Letters of Registration granted to Arthur Albert Bushell, this nineteenth day of January, A.D. 1883.

UGUSTUS LOFTUS.

---

REPORT.

Sir,

In accordance with your letter of the 13th November, we have examined the specification and plan attached to the application of Arthur Albert Bushell, for protection for an invention or improvement in the manufacture of Spring Mattresses, Couches, and Chairs, in which springs may be used, and have to report that we see no reason why the protection sought should not be granted.

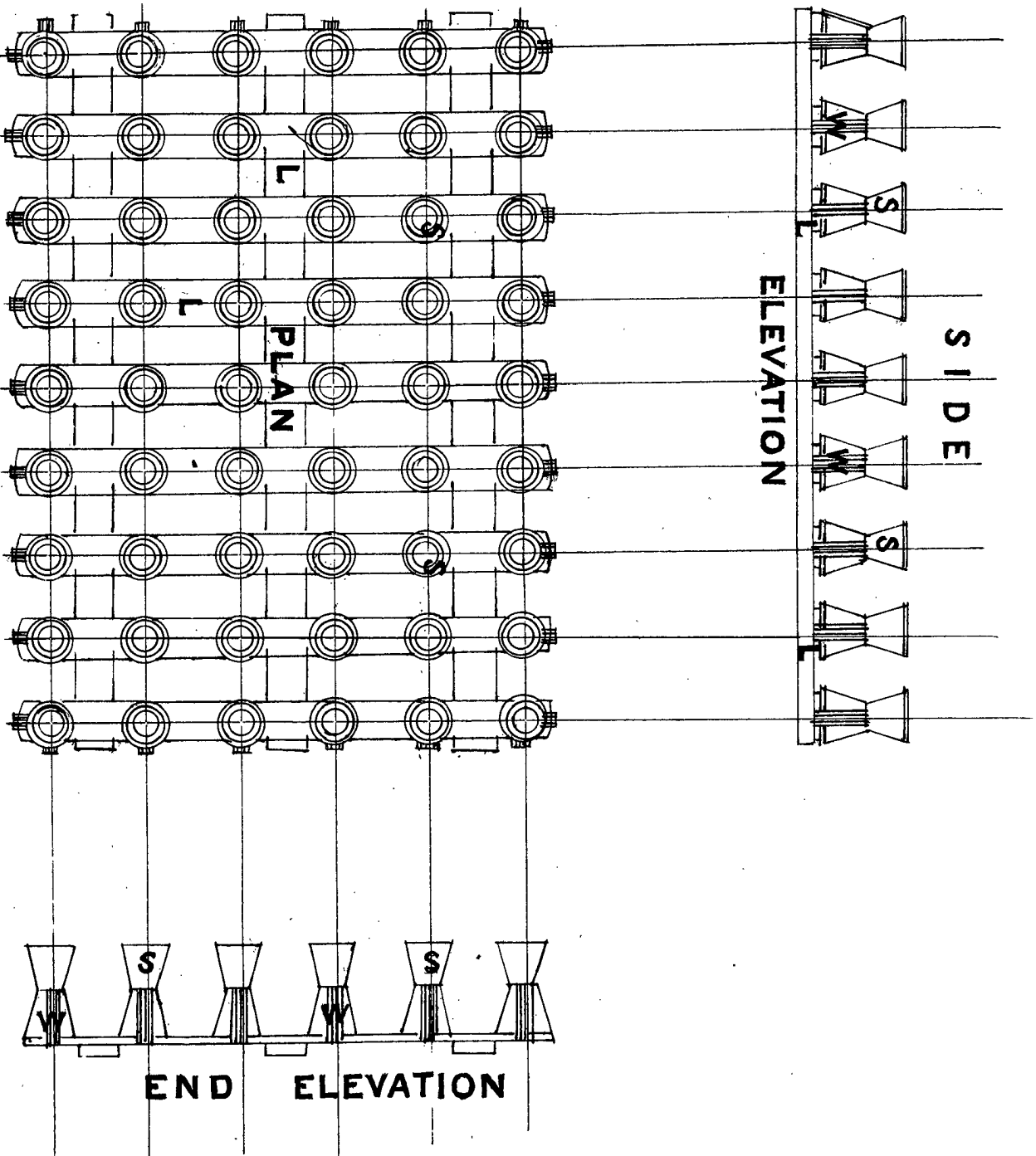
We have, &c.,

JAMES BARNET.  
WILLIAM C. BENNETT.

The Under Secretary of Justice.

---

[Drawings—one sheet.]



*This is the Sheet of Drawings referred to in the annexed Letters of Registration granted to Arthur Albert Bushell, this nineteenth day of January A. D. 1883.*

*Augustus Loftus.*

*Arthur Albert Bushell*



A.D. 1883, 6th February. No. 1191.

IMPROVEMENT IN THE MANUFACTURE OF PORTLAND CEMENT.

LETTERS OF REGISTRATION to George Richard Dibbs and Frederick Hugh Thomas.

[Registered on the 6th day of February, 1883, in pursuance of the Act 16 Vic. No. 24.]

BY HIS EXCELLENCY THE RIGHT HONORABLE SIR AUGUSTUS WILLIAM FREDERICK SPENCER LOFTUS (commonly called LORD AUGUSTUS LOFTUS), Knight Grand Cross of the Most Honorable Order of the Bath, a Member of Her Majesty's Most Honorable Privy Council, Governor and Commander-in-Chief of the Colony of New South Wales and its Dependencies.

TO ALL TO WHOM THESE PRESENTS SHALL COME, greeting:

WHEREAS George Richard Dibbs, of Sydney, in the Colony of New South Wales, gentleman, and Frederick Hugh Thomas, of Sydney aforesaid, civil engineer and architect, have by their Petition humbly represented to me that they are the authors or designers of a certain invention or improvement in manufactures, that is to say, of an invention entitled "An improvement in the manner of manufacturing Portland Cement, to be called 'Australasian Portland Cement,'" which is more particularly described in the amended specification which is hereunto annexed; and that they, the said Petitioners, have deposited with the Honorable the Treasurer of the said Colony of New South Wales the sum of Twenty Pounds sterling, for defraying the expense of granting these Letters of Registration, as required by the Act of Council, sixteenth Victoria, number twenty-four; and have humbly prayed that I would be pleased to grant Letters of Registration, whereby the exclusive enjoyment and advantage of the said invention or improvement might be secured to them for a period of fourteen years: And I, being willing to give encouragement to all inventions and improvements in the arts or manufactures which may be for the public good, and having received a report favourable to the prayer of the said Petition, from competent persons appointed by me to examine and consider the matter stated therein and to report thereon for my information, am pleased, with the advice of the Executive Council, and in exercise of the power and authority given to me by the said Act of Council, to grant, and do by these Letters of Registration grant unto the said George Richard Dibbs and Frederick Hugh Thomas, their executors, administrators, and assigns, the exclusive enjoyment and advantage of the said invention or improvement, for and during the term of fourteen years from the date hereof; to have, hold, and exercise unto the said George Richard Dibbs and Frederick Hugh Thomas, their executors, administrators, and assigns, the exclusive enjoyment and advantage thereof, for and during and unto the full end and term of fourteen years from the date of these presents next and immediately ensuing, and fully to be complete and ended: Provided always, that if the said George Richard Dibbs and Frederick Hugh Thomas shall not, within three days after the granting of these Letters of Registration, register the same in the proper office in the Supreme Court, at Sydney, in the said Colony of New South Wales, then these Letters of Registration, and all advantages whatsoever hereby granted, shall cease and become void.

In witness whereof, I have hereunto set my sign manual, and have caused the present Letters of Registration to be sealed with the seal of the said Colony of New South Wales, at Government House, Sydney, in New South Wales, this sixth day of February, in the year of our Lord one thousand eight hundred and eighty-three.

[L.S.]

AUGUSTUS LOFTUS.

---

*Improvement in the Manufacture of Portland Cement.*

---

TO ALL TO WHOM THESE PRESENTS SHALL COME, We, GEORGE RICHARD DIBBS, of Sydney, in the Colony of New South Wales, gentleman, and FREDERICK HUGH THOMAS, also of Sydney, in the said Colony, civil engineer and architect, send greeting.

WHEREAS we are desirous to obtain Letters of Registration for securing unto us Her Majesty's special license that we, our executors, administrators, and assigns, and such others as we or they shall at any time agree with and no others, shall and lawfully may from time to time, and at all times during the term of fourteen years, to be computed from the day on which this instrument is left at the office of the Colonial Secretary, Sydney, make, and exercise, use, and vend, within the Colony of New South Wales, an invention of, or an improvement in the manner of manufacturing Portland Cement, to be called "Australasian Portland Cement," as more particularly described and shown in the following specification and description, that is to say :—

SPECIFICATION of the Manufacture of "Australasian Portland Cement."

WE take a certain quantity of carboniferous limestone, equal by weight to one-fourth of the whole amount of the carbonate of lime required, and we reduce this to an impalpable powder; half of this powder, or such other proportion as the character of the stone may render necessary, we convert into chloride of calcium; to the above we add hydrate of lime in quantity three times as much as the above-named powder; to this we add shale, clay, slate, or toadstone, also reduced to like powder and containing the necessary proportions of silica and alumina, and from which material sulphur, when found in undue quantity, is first extracted by mildly burning or roasting thereof. We then thoroughly mix the whole by means of creepers or other suitable machinery, delivering it therefrom into the hoppers of a powerful direct-acting steam pressing machine, by which the said powder is moulded into ball or brick shaped blocks, so dense and dry as to permit them being placed in the kiln and burnt at once, to be afterwards crushed and ground in the usual manner.

We claim—

First—The use of chloride of calcium in manufacturing the cement, and in the manner above described.

Second—The mode of extracting sulphur from the materials named and used.

Third—The consolidating of the powdered materials into ball or brick shaped blocks so dense and dry as to render them fit for burning at once, and which we term our dry process of manufacture.

GEORGE R. DIBBS.  
FREDK. H. THOMAS.

—

This is the amended specification referred to in the amended Letters of Registration granted to George Richard Dibbs and Frederick Hugh Thomas, this sixth day of February, A.D. 1883.

AUGUSTUS LOFTUS.

---

REPORTS.

Sir,

The application of Messrs. George R. Dibbs and Frederick H. Thomas for Letters of Registration for the manufacture of cement having been referred to us, we have examined the specification accompanying the same, and have the honor to report that the material ground dry has already been registered. If the claim be confined to the dry process in moulding or shaping the ball or blocks before burning we see no objection to the issue of Letters of Registration.

We have, &c.,  
JAMES BARNET.  
CHAS. WATT.

The Under Secretary of Justice.

28 December, 1882.

WE see no objection to the issue of Letters of Registration to the applicants in accordance with their amended specification.

JAMES BARNET.  
CHAS. WATT.

---

No. 1192.

[Assignment of No. 1181. See Letters of Registration for 1883, page 19.]



A.D. 1883, 12th February. No. 1193.

IMPROVEMENTS IN PISTON ROD PACKINGS.

LETTERS OF REGISTRATION to the Jerome Automatic Packing Company (Limited), for Improvements in Piston Rod Packings.

[Registered on the 13th day of February, 1883, in pursuance of the Act 16 Vic. No. 24.]

BY HIS EXCELLENCY THE RIGHT HONORABLE SIR AUGUSTUS WILLIAM FREDERICK SPENCER LOFTUS (commonly called LORD AUGUSTUS LOFTUS), Knight Grand Cross of the Most Honorable Order of the Bath, a Member of Her Majesty's Most Honorable Privy Council, Governor and Commander-in-Chief of the Colony of New South Wales and its Dependencies.

TO ALL TO WHOM THESE PRESENTS SHALL COME, greeting :

WHEREAS THE JEROME AUTOMATIC PACKING COMPANY (LIMITED), of 8, Union Court Chambers, Old Broad-street, City of London, England, hath by its Petition humbly represented to me that it is the assignee of Charles Coburn Jerome, who is the author or designer of a certain invention or improvement in manufactures, that is to say, of an invention entitled "Improvements in Piston Rod Packings," which is more particularly described in the specification marked "A" and the two sheets of drawings marked "B" and "C" respectively which are hereunto annexed ; and that we, the said Petitioner, hath deposited with the Honorable the Treasurer of the said Colony of New South Wales the sum of Twenty Pounds sterling, for defraying the expense of granting these Letters of Registration, as required by the Act of Council, sixteenth Victoria, number twenty-four ; and hath humbly prayed that I would be pleased to grant Letters of Registration, whereby the exclusive enjoyment and advantage of the said invention or improvement might be secured to it for a period of fourteen years : And I, being willing to give encouragement to all inventions and improvements in the arts or manufactures which may be for the public good, and having received a report favourable to the prayer of the said Petition from competent persons appointed by me to examine and consider the matters stated therein and to report thereon for my information, am pleased, with the advice of the Executive Council, and in exercise of the power and authority given to me by the said Act of Council, to grant, and do by these Letters of Registration grant unto the said Jerome Automatic Packing Company (Limited) and its assigns the exclusive enjoyment and advantage of the said invention or improvement for and during the term of fourteen years from the date hereof ; to have, hold, and exercise unto the said Jerome Automatic Packing Company (Limited) and its assigns the exclusive enjoyment and advantage thereof, for and during and unto the full end and term of fourteen years from the date of these presents next and immediately ensuing, and fully to be complete and ended : Provided always that if the said Jerome Automatic Packing Company (Limited) shall not within three days after the granting of these Letters of Registration register the same in the proper office of the Supreme Court, at Sydney, in the said Colony of New South Wales, then these Letters of Registration and all advantages whatsoever hereby granted, shall cease and become void.

In witness whereof, I have hereunto set my sign manual, and have caused the present Letters of Registration to be sealed with the seal of the said Colony of New South Wales, at Government House, Sydney, in New South Wales, this twelfth day of February, in the year of our Lord one thousand eight hundred and eighty-three.

[L.S.]

AUGUSTUS LOFTUS.

*Improvements in Piston Rod Packings.*

A.

SPECIFICATION of THE JEROME AUTOMATIC PACKING COMPANY (LIMITED), of 8, Union Court Chambers, Old Broad-street, City of London, England, for an invention entitled "Improvements in Piston Rod Packings."

THIS invention consists in certain features of construction and combinations of parts as will hereinafter be described.

In the accompanying drawings, division No. 1, figure 1, is a vertical section of stuffing box and piston packing; figure 2 is a plan view of the gland of stuffing box; figure 3 is a plan view of metallic packing rings; figure 4, view in perspective of metallic packing ring in its open position; and figure 5 is a vertical section of a valve steam packing; figure 6, perspective view of, T<sup>2</sup>, division 2; figure 1 is a square shoulder piston, and figures 2, 3, 4, and 5 details of packing rings and glands to fit same, made in two or more pieces. A represents one head of a steam cylinder, and B the stuffing box, having an outwardly projecting flange, C, formed thereon, upon the outer face of which is seated the gland, D, the latter being retained in place by means of the stud-bolts, E. Within the opening, F, in the gland is located a packing cone, G, which is provided with an outwardly projecting flange or collar, H, the latter being seated within an annular groove, I, formed between the stuffing box or gland, and by means of which the packing cone is retained in place. In order to provide for lateral play or movement of the packing cone, due to the uneven wearing of the piston or other cause, the said groove, I, is of greater depth than the width of the flange or collar, H, thereby insuring a space, *a*, on the outside of the collar, H, for the free lateral movement of the packing cone. A conical or converging space, J, is formed within the packing cone for the reception of the metallic packing ring, K, while the outer end of the packing cone is formed to snugly fit the piston rod, L. A follower, M, is located within the stuffing box, the outer end, *b*, of the follower being made to correspond in form to the rear surface of one of the packing rings, and form a seat therefor, while the opposite end of the follower is provided with a flange, M<sup>1</sup>, which constitutes a seat for the outer end of the spiral spring, N, the latter being retained out of contact with the piston rod by means of the rear projection, N<sup>1</sup>, on the follower. The said flange, M<sup>1</sup>, is of less diameter than the interior of the stuffing box to insure annular steam passage, *c*, between the flange and stuffing box for the purpose of allowing steam to flow on the opposite sides of the flange, M<sup>1</sup>, and operate as a cushion to prevent the wedging of the rings or any undue pressure thereon. The opposite end of spiral spring, N, is seated upon the bushing ring, O. The outer end of the gland, D, is provided with an inwardly projecting flange, F<sup>1</sup>, against the inner face of which is seated a ring, F<sup>2</sup>, provided with the tapering or bevelled face, *f*<sup>2</sup>; F<sup>3</sup> represents fibrous material located between the ring, F<sup>2</sup>, and outer end of the packing cone. This fibrous material is situated with lubricating material, and serves to lubricate the piston rod and effectually prevent the admission of grit or dust within the packing cone. The follower, M, and bushing, O, are each provided with water grooves, *m*<sup>2</sup>, in which water collects and serves to pack the piston rod. The metallic packing rings are formed of any suitable metal, and cast with a single lap joint, *d*, the adjacent ends of the ring at the joint being formed, gradually tapering, as shown, to enable the rings to close around the piston rod and preserve their circular form, and thus insure a steam-tight joint. Each ring is provided with an annular flat seat, *e*, and bevelled seat or portion, *e*<sup>1</sup>, on its rear surface, and with a flat seat, *f*, and bevelled seat or surface, *f*<sup>1</sup>, on its front side. The outer surface, *g*, of the ring is made slightly tapering from its rear to its front side to cause the ring to adapt itself to the tapering or conical packing receptacle, and be readily forced when worn into the outer and contracted end of said receptacle, while the interior or wearing surface, *h*, of the ring is made to fit snugly against the piston rod. In casting or moulding the packing rings, a T-shaped piece of metal is placed in the mould at the back of the ring; if the ring is to be formed of two connected sections, so that when the ring is withdrawn from the mould, the inner portion thereof will be separated, as at *v*, while the outer portion of the ring will be separated from the inner portion by the elongated slots or openings, *v*<sup>1</sup>, *v*<sup>2</sup>, thus furnishing an elongated connecting strip, V, between the two sections. It is necessary to insure sufficient length to the connecting strip or portion, V, to allow the two portions of the ring to be bent toward and away from each other without danger of breaking the sections apart. When the packing rings are secured in place the flat annular seat, *e*, on the rear side of one ring, will rest upon the flat annular seat, *f*, upon the front side of the next ring. The forward ends of the rings are cut off as at *i*, so that when the rings are arranged within the packing cone several annular grooves, *j*, will be formed in the rear portion of the metallic packing surface, within which grooves the lubricating material will accumulate and operate to thoroughly lubricate the piston rod.

Figure 5 represent a valve steam packing embodying the invention, wherein R is the stuffing box, which is constructed separate from the valve-chest and adapted to be secured thereto by means of bolts inserted through the flange, R<sup>1</sup>, and the valve-chest. The stuffing box, R, is provided with a bushing, S, which is turned to snugly fit the valve stem, S<sup>1</sup>. Within the cylindrical bore of the bushing, S, are formed any desired number of annular grooves, *s*, which fill with water in the operation of the device, and thus serve to water pack the valve stem. T is a face plate having a conical or tapering receptacle, T<sup>1</sup>, formed on its inner surface for the reception of metallic packing-rings or fibrous packing material, T<sup>2</sup>, the packing being retained in contact with the valve stem by means of a spiral spring, T<sup>3</sup>, one end of which is seated upon the outer end, *t*, of the bushing, S, while the opposite end of the spring rests upon the following ring, U, which seats against the packing. The elongated bushing, S, serves to retain the valve stem in perfect line, and thus prevent the valve yoke from pounding the valve, or uneven wear of the valve, stem, or packing. The outer end of the face plate is screw threaded for the attachment of the cap, V, against the inner surface of which is seated a ring, V<sup>1</sup>, situated around the valve stem. The fibrous material, V<sup>2</sup>, is saturated with lubricating material, and discharges it upon the valve stem, and also serves to prevent the admission of dust or grit to the packing. W is a drip pipe for the escape of water from the interior of the stuffing box. C is the cap which holds the split gland or packing receptacle in place. H the packing receptacle or split gland. AAA rings which hold the packing receptacle or split gland in place and prevents it from coming apart. M is the follower also in two pieces, and held intact by the ring, M<sup>2</sup>, at one end, and by passing into the packing receptacle or split gland at the other end. E is the spiral spring which automatically feeds the packing rings forward into the conical part of the packing receptacle, and causes them to be forced to a bearing

*Improvements in Piston Rod Packings.*

bearing on the rod and form a steam-tight joint. Ring A is ground to a steam-tight joint in the recess in the cap; said ring is of less diameter than the diameter of the recess, thus allowing space for the packing receptacle to move laterally to keep in line with the cross-head. By this device a skilled mechanic is enabled to apply a conical packing gland to a piston rod having its ends larger than the body of the rod where the packing receptacle or gland is required to fit and still be able to realize all the advantages of a movable packing receptacle. Sectional packing rings of metal of any desired composition may be used.

## CLAIMS :—

1. A metallic packing ring provided with a single lap joint, the inner portion of the ring being partly severed at one or more points, substantially as set forth.
2. A metallic packing ring provided with flat annular bearings on its opposite side, and formed with a single lap joint, the inner portion of the ring being severed at one or more points, substantially as set forth.
3. A metallic packing ring having its inner or wearing faces subdivided into two or more sections which are connected by an outer portion of the ring, substantially as set forth.
4. The combination with a packing cone and follower of a series of metallic packing rings, each provided with flat annular seats on their front and rear sides, substantially as set forth.
5. The combination with a packing cone and follower of a series of metallic packing rings formed with a single lap joint, and with the converging end of the ring cut away to form lubricating grooves between the adjacent rings, substantially as set forth.
6. The combination with the conical packing receptacle and metallic packing rings of the face plate, a ring seated against the inner face, and fibrous material located between said ring and outer end of the packing receptacle, substantially as set forth.
7. The combination with a stuffing box provided with a face plate having a tapering or conical recess formed on its inner side of an elongated guide for the valve stem located in the stuffing box next to the valve chest, and serving to prevent lateral displacement of the valve stem, and a spring interposed between said elongated guide and the packing, substantially as set forth.
8. The combination with the stuffing box of a face plate having a conical receptacle formed therein, and adapted to enter the outer end of the stuffing box, substantially as set forth.
9. The combination with the face plate having a conical packing receptacle formed therein of a bushing provided with water grooves, and a spring seated on the bushing at one end and follower at its opposite end, substantially as set forth.
10. A gland made to contain a movable packing receptacle in two or more pieces as shown and described.
11. A receptacle for metallic packing made in two or more pieces and adjustable to a piston rod having either end of greater diameter than the body or shaft of the rod where it runs through the packing.

In witness whereof I, Charles Barrett, Secretary of the Jerome Automatic Packing Company (Limited), have hereto set my hand and the company's seal, this seventeenth day of July, A.D. 1882.

JEROME AUTOMATIC PACKING COMPANY (LIMITED).  
CHAS. BARRETT, Secretary.

Witness—

A. E. MELHUISE.

This is the specification marked "A" referred to in the annexed Letters of Registration granted to the Jerome Automatic Packing Company (Limited), this twelfth day of February, A.D. 1883.

AUGUSTUS LOFTUS.

## REPORT.

Sir,

Having examined the specification and plans accompanying the petition, we have the honor to recommend that Letters of Registration should be issued to the Jerome Automatic Packing Company (Limited) for an invention entitled "Improvements in Piston Rod Packings," as shown in the drawings and described in the specification attached to their petition.

Sydney, 27 September, 1882.

We have, &c.,

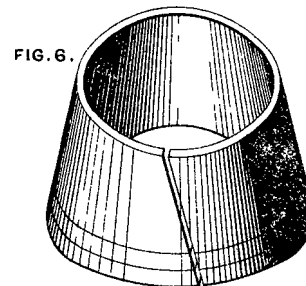
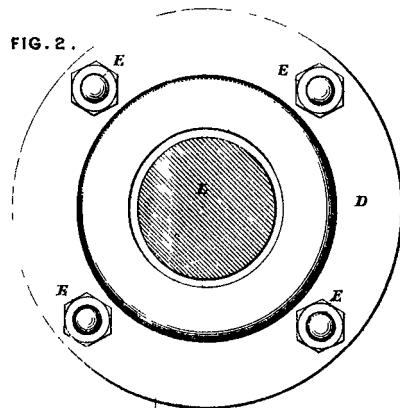
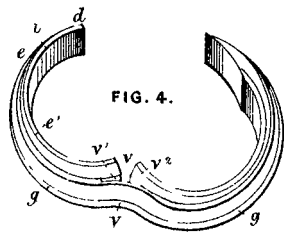
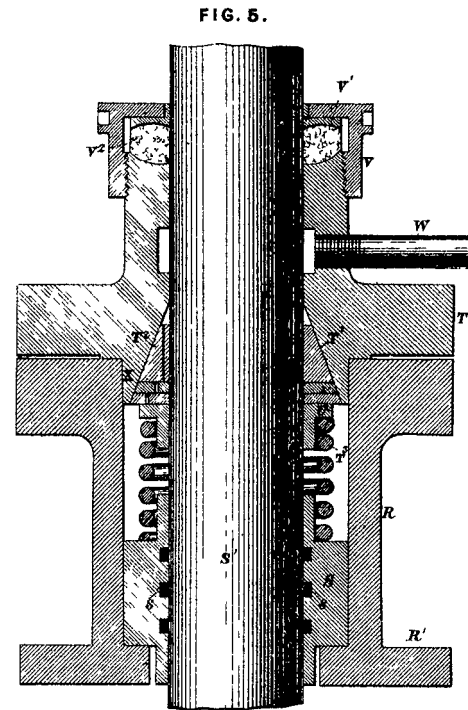
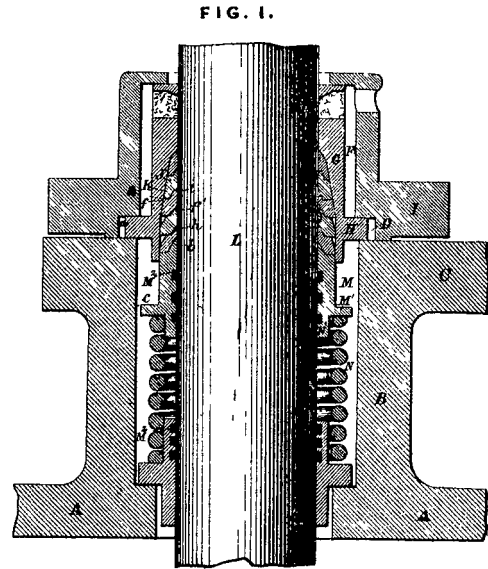
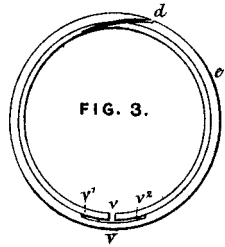
JOHN WHITTON.  
E. O. MORIARTY.

The Under Secretary of Justice.

[Drawings—two sheets.]

B.

1193.  
Nº 1.



*This is the Sheet of Drawings marked B referred to in the annexed Letters of Registration granted to The Jerome Automatic Packing Company Limited this twelfth day of February A. D. 1883.*

*Augustus Loftus:*

PHOTO-LITHOGRAPHED AT THE GOVT. PRINTING OFFICE,  
SYDNEY, NEW SOUTH WALES

*Fig 35*



C.

FIG. 1.

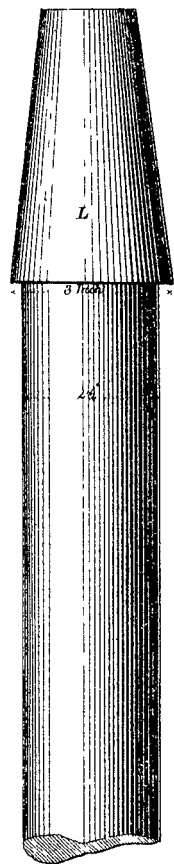


FIG. 2.

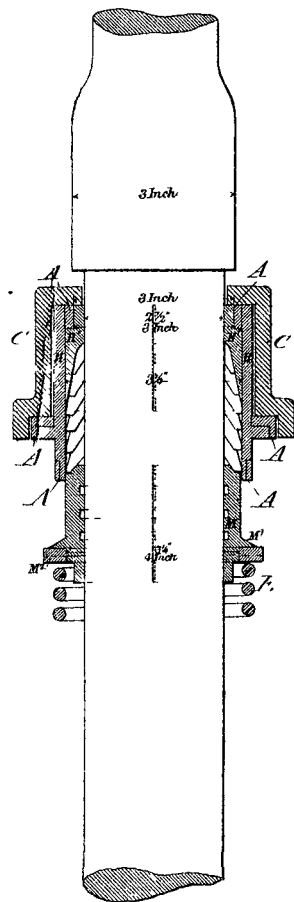


FIG. 3.

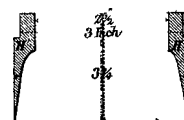


FIG. 4.

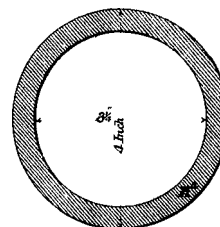
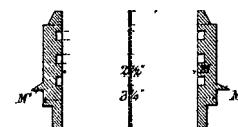


FIG. 5.



*This is the Sheet of Drawings marked C referred to in the annexed Letters of Registration granted to The Jerome Automatic Picking Company Limited this twelfth day of February A.D. 1883.*

*Augustus Loftus.*

TROTT & SON, LITH. 10 KING ST. COVENT GARDEN.

*Sig 35*




---

A.D. 1883, 12th February. No. 1194.

---

**IMPROVEMENTS IN ROCK DRILLING MACHINE.**

**LETTERS OF REGISTRATION** to Milan Constant Bullock, for an Invention entitled "Improvements in Rock Drilling Machine."

[Registered on the 13th day of February, 1883, in pursuance of the Act 16 Vic. No. 24.]

---

BY HIS EXCELLENCY THE RIGHT HONORABLE SIR AUGUSTUS WILLIAM FREDERICK SPENCER LOFTUS (commonly called LORD AUGUSTUS LOFTUS), Knight Grand Cross of the Most Honorable Order of the Bath, a Member of Her Majesty's Most Honorable Privy Council, Governor and Commander-in-Chief of the Colony of New South Wales and its Dependencies.

TO ALL WHOM THESE PRESENTS SHALL COME, greeting :

WHEREAS MILAN CONSTANT BULLOCK, of the city of Chicago, in the county of Cook, and State of Illinois, in the United States of America, hath by his Petition humbly represented to me that he is the author or designer of a certain invention or improvement in manufactures, that is to say, of an invention entitled "Improvements in Rock Drilling Machine," which is more particularly described in the specification, marked A, and the two sheets of drawings, marked B and C respectively, which are hereunto annexed ; and that he, the said Petitioner, hath deposited with the Honorable the Treasurer of the said Colony of New South Wales the sum of Twenty Pounds sterling, for defraying the expense of granting these Letters of Registration, as required by the Act of Council, sixteenth Victoria, number twenty-four ; and hath humbly prayed that I would be pleased to grant Letters of Registration, whereby the exclusive enjoyment and advantage of the said invention or improvement might be secured to him for a period of fourteen years : And I, being willing to give encouragement to all inventions and improvements in the arts or manufactures which may be for the public good, and having received a report favourable to the prayer of the said Petition, from competent persons appointed by me to examine and consider the matters stated therein and to report thereon for my information, am pleased, with the advice of the Executive Council, and in exercise of the power and authority given to me by the said Act of Council, to grant, and do by these Letters of Registration grant unto the said Milan Constant Bullock, his executors, administrators, and assigns, the exclusive enjoyment and advantage of the said invention or improvement, for and during the term of fourteen years from the date hereof ; to have, hold, and exercise unto the said Milan Constant Bullock, his executors, administrators, and assigns, the exclusive enjoyment and advantage thereof, for and during and unto the full end and term of fourteen years from the date of these presents next and immediately ensuing, and fully to be complete and ended : Provided always, that if the said Milan Constant Bullock shall not, within three days after the granting of these Letters of Registration, register the same in the proper office in the Supreme Court, at Sydney, in the said Colony of New South Wales, then these Letters of Registration, and all advantages whatsoever hereby granted, shall cease and become void.

In witness whereof, I have hereunto set my sign manual, and have caused the present Letters of Registration to be sealed with the seal of the said Colony of New South Wales, at Government House, Sydney, in New South Wales, this twelfth day of February, in the year of our Lord one thousand eight hundred and eighty-three.

[L.S.]

AUGUSTUS LOFTUS.

*Improvement in Rock Drilling Machine.*

A.

SPECIFICATION of MILAN CONSTANT BULLOCK, of the city of Chicago, in the county of Cook and State of Illinois, in the United States of America, for an invention entitled "Improvement in Rock Drilling Machine."

MY invention consists in the application to a rock-drill of a two-cylinder steam-engine for operating the drilling and hoisting machinery, the steam induction and exhaust device of which are so constructed and applied that the cylinders and their adjuncts may be used either conjointly as a compound steam-engine or separately as two independent high pressure steam-engines, having a common crank-shaft. It further consists of a peculiarly constructed variable and reversible eccentric for operating the steam valves; and the invention further consists in arranging the hoisting apparatus on the frame of the machine below the crank-shaft for the purpose of obtaining great strength and stability, combined with lightness and compactness.

It further consists of certain combinations of devices, which are set forth specifically in claims at the close of this specification, for operating the brakes of the hoisting apparatus.

In order that my invention may be fully understood, I have illustrated in the annexed drawings, and will describe the best form thereof at present known to me.

Figure 1 is a front elevation of my improved steam rock drill.

Figure 2 is a side elevation of the same.

Figure 3 is a vertical longitudinal section in the plane indicated by broken line 1 1 in figure 1.

Figure 4 is a transverse section substantially in the two planes indicated by the broken lines 2 2 and  $xx$  in figure 2 and looking in the direction of the arrow thereon.

Figure 5 is a transverse section substantially in the planes indicated by the broken line 3 3 of figure 3, and looking in the direction of the arrow thereon.

Figure 6 is a section in the plane indicated by broken line 4 4, of figure 4.

Figure 7 is an isometrical perspective of one of the cross-heads.

Figure 8 is an isometrical perspective of one of the valve rod-guides.

Figures 9, 10, 11, 12, and 13 are detail illustrations of the duplex eccentric.

Figures 14, 15, 16, 17, and 18 are detail illustrations of the steam induction and exhaust devices.

Figure 19 is an end view; figure 20 a plan view; figure 21 is a side elevation of the hoisting drum; and figure 22 shows the application of the cam-brake lever.

Figures 7 to 18 are drawn on a larger scale than the other figures, but the same letters of reference are used in all the figures to indicate like parts.

All the machinery is supported on the bed-plate A and the three braced standards  $A^1$ ,  $A^2$ ,  $A^3$  bolted thereto. The steam cylinders B and C bolted to the bed-plate are set at reverse angles of  $45^\circ$  to the base thereof, and at right angles to each other. Their piston-rods work through suitable stuffing-boxes in the upper heads of the cylinders, and are connected to the respective pitmen  $B^1$  and  $C^1$  by means of cross-heads, preferably such as illustrated in detail in figure 7, and running on single guide-bars suitably secured at one end to the cylinder, and at the other end to a brace between the standards  $A^1$  and  $A^2$ . The cylinders are set in different transverse planes, in order that their pitmen may just pass each other and be connected side by side to the same double crank  $D^1$  of the main or crank-shaft D.

The slide-valve of each cylinder is secured to a stem which terminates at its outer end in a square or polygonal bar, forming a slide which is fitted and moves in a fixed guide secured to the standard  $A^2$ , as shown in figure 5, and in detail in figures 6 and 8.

The two slide-valves are operated by one variable and reversible duplex eccentric E, provided with the two straps  $E^1$  and  $E^2$ , from which the respective eccentric rods  $E^3$   $E^4$  extend divergently to the slide-valve stems, to which they are pivoted.

The eccentric is pivoted at  $e$  to an arm,  $e^1$ , fixed on the crank-shaft, which latter passes through a curved slot,  $e^2$ , formed in the eccentric so that the eccentric may be swung on its pivot,  $e$ , to adjust it with reference to the double-crank  $D^1$ .

The curved slot  $e^2$  of the eccentric is so located and proportioned that the engine or engines may be reversed by swinging the eccentric from one extreme position to the other. By lesser adjustments of the eccentric the lead of the slide-valves may also be readily adjusted. The eccentric thus pivoted is connected by a link,  $e^3$ , to an arm on the adjacent end of a sleeve,  $f$ , which is fitted on the crank-shaft so that it may be turned, but cannot move endwise thereon. The sleeve is constructed with spiral-ribs or threads,  $f$ , on its surface, and is encircled by a bush,  $G^1$ , in which spiral grooves,  $g$ , are cut to engage the spiral threads on the sleeve. The bush is fixed in the split end of a tubular slide, G, so as to form part thereof. The other and contracted end of the tubular slide is connected by feather and groove to the crank-shaft, with which it turns, but on which it may be slid endwise. Thus the bushed tubular slide will firmly hold the sleeve, and through it the eccentric.

It will be perceived, however, that by sliding the tubular slide on the crank-shaft its spirally grooved bush will turn the spirally threaded sleeve, which will in turn swing the eccentric on its pivot.

The tubular slide is encircled by a ring,  $G^2$ , studs on which are engaged by the forks of the reversing lever, H, by operating which the eccentric may be adjusted at pleasure. The split end of the tubular slide is constructed with ears, so that the segments may be drawn together by bolts, as clearly shown in figures 6, 11, and 12, and lost motion between the spiral threads and spiral grooves be readily taken up.

It is obvious that an eccentric carrying a single strap only may be constructed in other respects like the duplex eccentric described.

Of the cylinders B is the larger and C the smaller. The steam is supplied through the pipe, I, governed by the throttle-valve or cock,  $I^1$ , which is operated by the lever,  $I^2$ , through a suitable connecting-rod,  $I^3$ , pivoted to a crank-pin,  $i$ , on the valve-stem.

The outlet,  $I^4$ , of the throttle-valve has a branch from which the steam induction pipe,  $I^5$ , leads to and covers the steam inlet of the steam-chest of the smaller cylinder C. The outlet,  $I^4$ , of the throttle-valve is connected to or forms one branch of the case K of a multi-way valve or cock, the plug,  $K^1$ , of which is provided with three separate and distinct passages  $k$ ,  $k^1$ ,  $k^2$ , while the case is constructed with three

*Improvement in Rock Drilling Machine.*

three lateral branches besides the branch I<sup>4</sup> already mentioned. The exhaust pipe C<sup>1</sup> from cylinder C is connected to the branch, K<sup>2</sup>, of the cock. From the branch, K<sup>3</sup>, of the same a jacketed steam induction pipe, K<sup>4</sup>, leads to and covers the steam inlet of the steam-chest of the larger cylinder, B, while another pipe, K<sup>5</sup>, leads from its branch, K<sup>5</sup>, to the coupling, L<sup>1</sup>, of the main exhaust pipe, L, with a nipple on the coupling of which the exhaust-pipe, B<sup>1</sup>, from the larger cylinder, B, is also connected. The plug of the multi-way cock is provided with a lever handle, K<sup>7</sup>, by which it may be turned. Whether the steam-cylinders and their adjuncts will operate conjointly as a compound steam-engine, or independently as two separate high pressure steam-engines, depends upon the position of the plug of the multi-way cock. If they are to operate as a compound steam-engine then the plug must be turned to the position shown in figure 15, so that live steam is admitted only to the smaller cylinder, and the exhaust steam therefrom is further utilized by the larger cylinder before it reaches the main exhaust-pipe, L. If on the other hand they are to operate independently as two separate high pressure steam-engines, then the plug must be turned to the position shown in figure 16, so that live steam will be admitted to both cylinders and the exhaust steam from each discharged directly into the main exhaust-pipe, L.

In performing average drilling work and for hoisting purposes the engines should be used as one compound steam-engine, in order to economize steam and use it to the best advantage. When extra power is required the engines should be used independently as two high pressure steam-engines.

The drilling mechanism and swivel head, M, may be constructed and mounted and driven in manner shown in the drawings. Detailed description thereof is deemed unnecessary herein because they form part of a separate application for letters of registration filed herewith.

The cylinders and their valve-chests are jacketed, and a steam-pipe, R, supplies these jackets and the jacket of steam induction pipe, K<sup>4</sup>, with live steam. With reference to the means for reversing the eccentric, it might be remarked that the sleeve instead of being provided with spiral ribs or threads might have spiral grooves formed in its surface, in which case the tubular slide would be provided with inwardly projecting studs or spiral ribs to engage said grooves. But I prefer the construction first hereinbefore described. Beyond the fly-wheel, N, a shiftable spur-pinion, O, is mounted on the crank-shaft for driving the hoisting machinery.

Referring more particularly to figures 19 to 22, the hoisting drum, P, is mounted to turn on the shaft, P<sup>1</sup>, which is supported in bearings on the standards A<sup>2</sup> and A<sup>3</sup> below the crank-shaft, D. A large spur-wheel, M<sup>1</sup>, is keyed to shaft P<sup>1</sup>, adapted to be driven by a spur-pinion, O, on the crank-shaft, the said pinion being so connected to the crank-shaft by feather and groove that it may be slid endwise thereon to throw it in and out of gear according as the hoisting apparatus is to be driven or not. The hoisting-drum is driven by the spur-wheel, M<sup>2</sup>, fixed on shaft, P<sup>1</sup>, through the intermediate spur-wheels, M<sup>3</sup>, which mesh with the internally-toothed but externally-smooth brake-rim, M<sup>4</sup>, on the hoisting-drum. The intermediate spur-wheels, M<sup>3</sup>, revolve on gudgeons, M<sup>5</sup>, carried by the thrust-wheel, M<sup>6</sup>, which is mounted to turn freely on shaft, P<sup>1</sup>, but may be held stationary by means of the friction-strap incircling its grooved rim.

This friction-strap is composed of two approximately semicircular segments, J J<sup>1</sup>, provided with ears, *j* and *j*<sup>1</sup>, at one end, which affords facility for bolting them together and for attaching this friction-strap to a cross-bar or bolt, J<sup>2</sup>, supported by standards, J<sup>3</sup> J<sup>3</sup>, rising from and secured to the bed-plate, A, as shown in figures 19 and 20. The other ends of the segments also terminate in laterally projecting ears, *j*<sup>2</sup> and *j*<sup>3</sup>, which are connected by an eye-bolt, J<sup>4</sup>, but will still be a little distance apart when the segments are drawn together to tightly hug the thrust-wheel, M<sup>6</sup>. The nuts of the eye-bolt are so adjusted that the wheel, M<sup>6</sup>, can move freely in the friction-strap. The eye-head of the eye-bolt, J<sup>4</sup>, is above the upper-ear, *j*<sup>2</sup>, and pivoted to it is a forked horizontally projecting cam-lever, Q, the cam-heads, *q*, of which bear on the upper side of said ear, *j*<sup>3</sup>, the cam-heads being so formed that by lifting the outer end or long arm of the lever its cam-heads will, in conjunction with the eyebolt, draw the segments of the friction-strap together and cause them to hug the thrust-wheel, M<sup>6</sup>.

A brake-strap, L<sup>4</sup>, constructed in all particulars like the friction-strap above described, encircles the brake-rim, M<sup>4</sup>, of the hoisting-drum, is secured to the same cross-bar or bolt, J<sup>2</sup>, to which the friction-strap is secured, and has the other ends of its segments in like manner connected by an eye-bolt, L<sup>1</sup>, to the eye-head of which is pivoted a forked horizontally projecting cam-lever, L<sup>2</sup>; but the eye-head of eyebolt, L<sup>1</sup>, is lowermost, so that the cam-heads of the lever, L<sup>2</sup>, bear on the under side of the ear of the lower segment of the brake-strap.

The respective eye-bolts and cam-levers are reversely arranged in order that they may be operated in the same axial line without interference. The forks of the long arm of cam-lever, L<sup>2</sup>, are connected by links, *l* and *l*<sup>1</sup>, to a nut, *m*<sup>1</sup>, on the screw-threaded portion, *m*, of the upright spindle, M<sup>7</sup>, which is at its lower end supported in and connected to the bed-plate, so that it may be turned axially but cannot move endwise. The upper end of this spindle is provided with a hand-wheel, M<sup>8</sup>, for turning it.

The spindle also carries a long sleeve, N<sup>4</sup>, fitted in a fixed yoke, M<sup>9</sup>, which latter forms a bearing for the sleeved spindle near its upper end. The lower end, *n*, of the sleeve is screw-threaded, and carries a nut, *n*<sup>1</sup>, to which the forks of the long arm of the cam-lever, Q, are connected by links, *k*<sup>1</sup> and *k*<sup>2</sup>. A shoulder, *n*<sup>2</sup>, on the sleeve is seated against the under side of yoke, M<sup>9</sup>, and immediately above the yoke a hand-wheel, N<sup>1</sup>, is fixed on the sleeve. Thus the sleeve may be independently turned on the spindle, but cannot move endwise. The cam-levers prevent the nuts to which they are respectively linked from turning, so that by turning the hand-wheels, M<sup>8</sup> and N<sup>1</sup>, the nuts will be compelled to travel up or down on the screw-threaded portions of the rotating spindle and rotating sleeve, whereby the friction-strap and brake-strap can be duly operated either simultaneously or independently.

It will be observed that while the friction strap may act as a brake, in conjunction with the thrust-wheel, to stop the hoisting-drum whenever the driving-pinion, O, is thrown out of gear, it cannot so act when said driving-pinion is in gear and running, but the brake-strap on the hoisting-drum may be used to stop the drum while pinion O is in gear and running, provided the friction-strap be opened to release thrust-wheel M<sup>6</sup>.

The arrangement of the hoisting apparatus below the crank-shaft of the engine or engines brings it close down to the foundation of the machine, making the whole structure not only more compact but also more stable, so that the parts may be made correspondingly lighter. The

*Improvements in Rock Drilling Machine.*

The height of the machine and the size of the frame-work are also reduced thereby. Usually the friction-strap is to be loosened simultaneously with tightening the brake-strap, and *vice versa*. Having the hand-wheels, M<sup>s</sup> and N<sup>1</sup>, one over the other, makes it very convenient to operate, one with the right hand and the other with the left hand, to simultaneously operate the two straps in that way. It is obvious that so far as the novel arrangement of the hoisting-drum is concerned it is immaterial whether the particular hoisting-drum hereinbefore described or any other known form of hoisting-drum is made use of, although I prefer the described form of hoisting-drum.

Having now described the nature of the said invention and the manner in which the same may be carried into practical effect, what I claim and desire to secure by letters of registration is:—

- 1st. The combination, substantially as before set forth, of two steam cylinders operating on a common crank-shaft and a multi-way valve or cock adapted to establish steam communication to the steam induction pipe of one of the cylinders, either from the throttle-valve direct or from the exhaust-pipe of the other cylinder, which is always supplied with steam direct from the throttle-valve.
- 2nd. The combination, substantially as before set forth, of the two cylinders, the slide-valves thereof, and the reversible duplex eccentric for operating said slide valves.
- 3rd. The combination, substantially as before set forth, of the slotted eccentric pivoted to an arm on the crank-shaft, the spirally threaded sleeve linked to the eccentric and the adjustable tubular slide, the spirally grooved bush of which engage the spirally threaded sleeve.
- 4th. In a rock-drill the combination, substantially as before set forth, of two steam-engines operating on a common crank-shaft, arranged at reverse angles of 45° on the bed-plate and at right angles to each other.
- 5th. The combination, substantially as before set forth, of the steam-cylinders set at reverse angles of 45° on the bed-plate and at right angles to each other, the crank-shaft overhead, the hoisting apparatus below the crank-shaft, and the wheel and pinion for transmitting the motion of the crank-shaft to the hoisting apparatus.
- 6th. The combination, substantially as before set forth, of the segments of the brake-strap, the eye-bolt, the cam-lever, the screw, and the travelling-nut connected with the cam-lever to prevent said nut from turning.
- 7th. The combination, substantially as before set forth, of the brake-strap, the friction-strap, the screw-spindle, screw-threaded sleeve thereon, and the two travelling-nuts for operating the cam-levers of the brake-strap and friction-strap, one nut being fitted on the screw-spindle and the other on the screw-threaded sleeve.

In witness whereof, I, the said Milan Constant Bullock, have hereunto set my hand and seal, this ninth day of September, in the year of our Lord one thousand eight hundred and eighty-two.

MILAN CONSTANT BULLOCK.

This is the specification marked "A" referred to in the annexed Letters of Registration granted to Milan Constant Bullock, this twelfth day of February, A.D. 1883.

AUGUSTUS LOFTUS.

---

REPORT.

---

Sir,

In accordance with your letter of the 5th December, we have examined the specification and plans attached to the application of Milan Constant Bullock, for protection for an invention entitled "Improvements in Rock Drilling Machines," and have to report that we see no reason why the protection sought should not be granted.

The Under Secretary of Justice.

Sydney, 14 December, 1882.

We have, &c.,

JAMES BARNET.

WILLIAM C. BENNETT.

---

[Drawings—two sheets.]

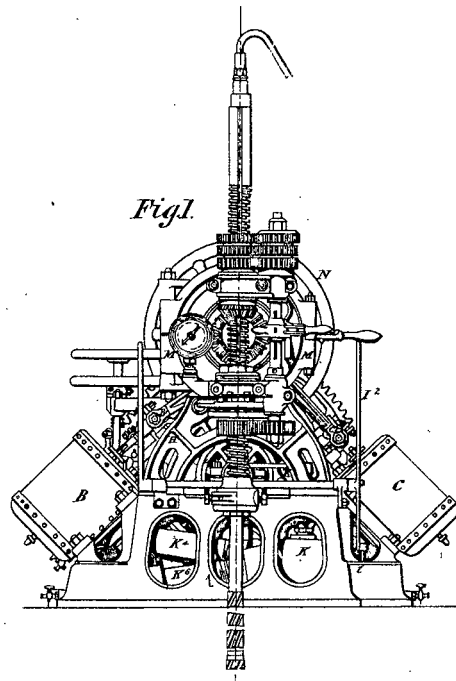


Fig. 1.

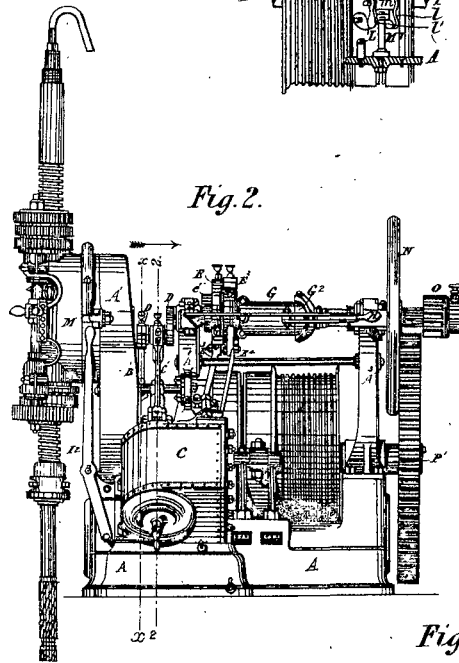


Fig. 2.

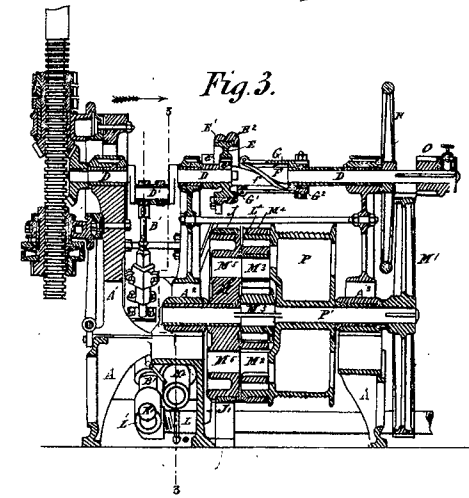


Fig. 3.

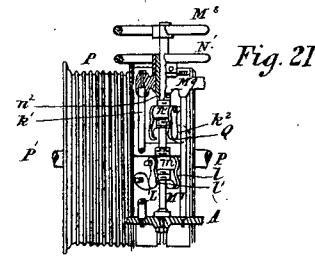


Fig. 21.

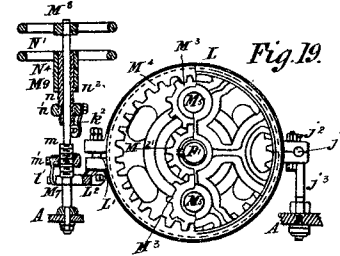


Fig. 19.

Fig. 22.

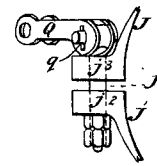
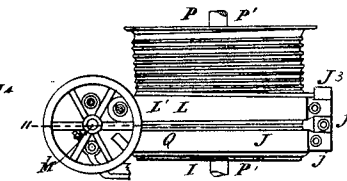


Fig. 20.



*This is the Sheet of Drawings marked B. referred to in the annexed Letters of Registration granted to Milan Constant Bullock, this twelfth day of February A. D. 1883.*

*Augustus Loftus.*

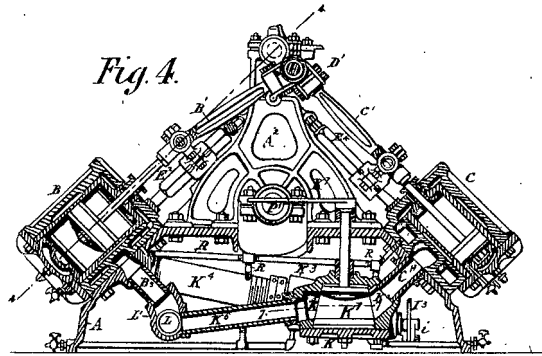


Fig. 4.

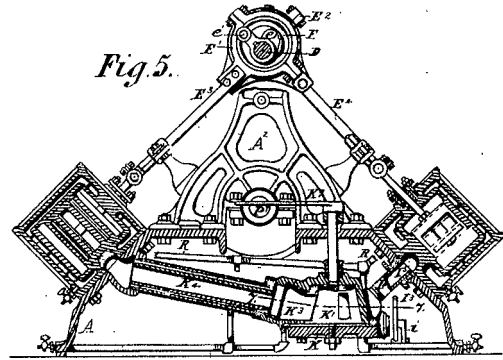


Fig. 5.

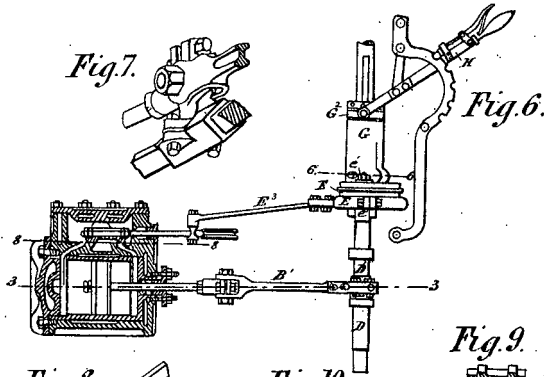


Fig. 6.

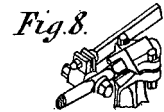


Fig. 8.



Fig. 10.

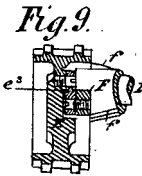


Fig. 9.



Fig. 12.

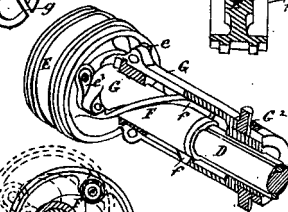


Fig. 11.

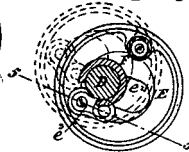


Fig. 13.

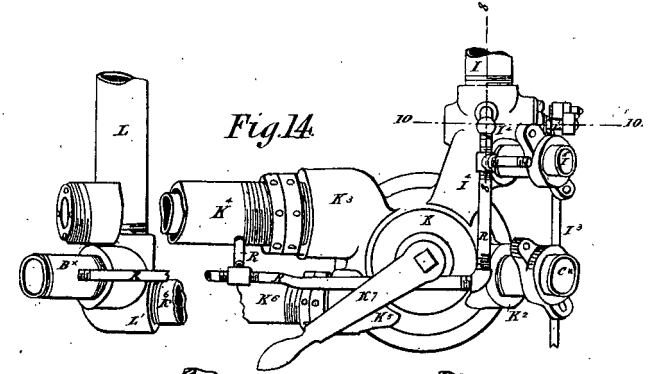


Fig. 14.

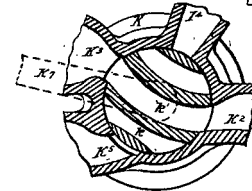


Fig. 15.

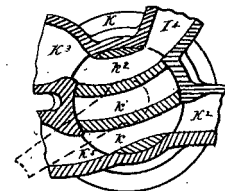


Fig. 16.

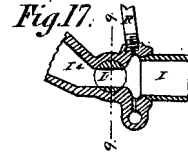


Fig. 17.

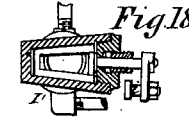


Fig. 18.

*This is the Sheet of Drawings marked C. referred to in the annexed Letters of Registration granted to Milan Constant Bullock this twelfth day of February A.D. 1883.*

*Augustus Loftus.*



A.D. 1883, 12th February. No. 1195.

IMPROVEMENTS IN ROCK-DRILLING MACHINE.

LETTERS OF REGISTRATION to Milan Constant Bullock, for an Invention entitled, "Improvements in Rock-drilling Machine."

[Registered on the 14th day of February, 1883, in pursuance of the Act 16 Vic. No. 24.]

BY HIS EXCELLENCY THE RIGHT HONORABLE SIR AUGUSTUS WILLIAM FREDERICK SPENCER LOFTUS (commonly called LORD AUGUSTUS LOFTUS), Knight Grand Cross of the Most Honorable Order of the Bath, a Member of Her Majesty's Most Honorable Privy Council, Governor and Commander-in-Chief of the Colony of New South Wales and its Dependencies.

TO ALL TO WHOM THESE PRESENTS SHALL COME, greeting :

WHEREAS MILAN CONSTANT BULLOCK, of the City of Chicago, in the County of Cook, and State of Illinois, in the United States of America, hath by his Petition humbly represented to me that he is the author or designer of a certain invention or improvement in manufactures, that is to say, of an invention entitled "Improvements in Rock-drilling Machine," which is more particularly described in the specification marked "A," and the three sheets of drawings marked "B," "C," and "D" respectively which are hereunto annexed; and that he, the said Petitioner, hath deposited with the Honorable the Treasurer of the said Colony of New South Wales the sum of Twenty Pounds sterling, for defraying the expense of granting these Letters of Registration, as required by the Act of Council, sixteenth Victoria, number twenty-four; and hath humbly prayed that I would be pleased to grant Letters of Registration whereby the exclusive enjoyment and advantage of the said invention or improvement might be secured to him for a period of fourteen years: And I, being willing to give encouragement to all inventions and improvements in the arts and manufactures which may be for the public good, and having received a report favourable to the prayer of the said Petition, from competent persons appointed by me to examine and consider the matters stated therein and to report thereon for my information, am pleased, with the advice of the Executive Council, and in exercise of the power and authority given to me by the said Act of Council, to grant, and do by these Letters of Registration grant unto the said Milan Constant Bullock, his executors, administrators, and assigns, the exclusive enjoyment and advantage of the said invention or improvement, for and during the term of fourteen years from the date hereof; to have, hold, and exercise unto the said Milan Constant Bullock, his executors, administrators, and assigns, the exclusive enjoyment and advantage thereof, for and during and unto the full end and term of fourteen years from the date of these presents next and immediately ensuing, and fully to be complete and ended: Provided always, that if the said Milan Constant Bullock shall not, within three days after the granting of these Letters of Registration, register the same in the proper office in the Supreme Court, at Sydney, in the said Colony of New South Wales, then these Letters of Registration, and all advantages whatsoever hereby granted, shall cease and become void.

In witness whereof, I have hereunto set my sign manual, and have caused the present Letters of Registration to be sealed with the seal of the said Colony of New South Wales, at Government House, Sydney, in New South Wales, this twelfth day of February, in the year of our Lord one thousand eight hundred and eighty-three.

[L.S.]

AUGUSTUS LOFTUS.



*Improvements in Rock-drilling Machine.*

"A."

SPECIFICATION of MILAN CONSTANT BULLOCK, of the City of Chicago, in the County of Cook, and State of Illinois, in the United States of America, for an invention entitled, "Improvements in Rock-drilling Machine."

MY invention relates to improvements in rotating diamond-pointed rock drills and to drilling machines for the same purpose which have a rotary motion imparted to their drills, but which are not provided with diamond points; and the objects of my invention are—first, to provide novel means of attaching the supports of the swivel-head to the machine; second, to combine with such machines an engine or engines constructed and arranged with special reference to the economy of space, and adapted to serve the double purpose of driving the drill and removing the same from the drilled hole; third, to combine with such an engine and drilling mechanism a hoisting device for raising the drill and its rods when removing them from the hole formed by the drill; and fourth, to provide the necessary combinations of mechanism for producing the results hereinafter described.

Oscillating engines have heretofore been used for propelling rock drills, but they have been found to be objectionable on account of the large amount of friction produced, and on account of the vibration caused when run at a high rate of speed.

I will now describe the general construction of my improved machine, referring more particularly to figures 1, 2, 3, and 13 to 27 inclusive, of which figure 1 is a front elevation of my improved rock-drilling machine; figure 2 is a side elevation thereof; figure 3 is a longitudinal sectional elevation thereof on line 1, 1, of figure 1; figure 13 is a vertical section on line 2, 2, figure 2, showing the position of the engine with relation to the driving-shaft; figure 14 is a section taken on line 3, 3, figure 13, showing the steam-chest, cylinder, &c.; figures 15, 16, and 17 are views in detail of that end of the connecting-rod which is united to the trunk; figure 18 is a plan of the upper cylinder head; figure 19 is a vertical section taken on line 5, 5, figure 14; figure 20 is a transverse section taken on line 6, 6, figure 19; figure 21 is a perspective of one of the valves, it being partly broken away to show the parts more clearly; figure 22 is a view on an enlarged scale, and partly in section, showing the steam-supply pipe, throttle-valve, &c.; figure 23 is a perspective view of the cross-head of the valve stem; figure 24 shows in elevation the front standard and its ring, the plate, and the yoke, the plate and yoke being broken away; figure 25 is a vertical section taken on line 7, 7, figure 24; figure 26 is a plan view, showing the manner of connecting the yoke to the plate; figure 27 is a front elevation of the plate.

The same letters of reference are used in all the figures in the designation of identical parts.

In constructing machines of this type there is provided a bed-plate, A, in which there is formed a steam chamber, A<sup>1</sup>, which receives steam from any conveniently located generator through a pipe, one end of which is in communication with said chamber. Within the chamber A<sup>1</sup> there is placed a throttle-valve, *a*, through which, and through the seat upon which it moves, there is an aperture for the passage of steam to a passage, A<sup>2</sup>, which conducts it to the steam-chest B<sup>1</sup>, in which there is placed a valve, B<sup>2</sup>, which, when properly moved, admits the steam to the cylinder, and, after it has been used therein, allows it to pass out through ports *b*<sup>3</sup> and *b*<sup>4</sup> in said valve into the exhaust passage A<sup>3</sup>, formed in the bed-plate.

The throttle-valve above alluded to is provided with a rod, *a*<sup>1</sup>, for operating it, said rod passing through a stuffing-box, *a*<sup>2</sup>, which may be constructed in any approved manner.

The cylinders BB are secured to the bed-plate A at an angle of 45 degrees to its base line, and at right angles to each other, as shown in figures 1 and 13.

By the side of each of these cylinders there is placed a steam-chest, B<sup>1</sup>, the angularity of which corresponds with that of the cylinders. These chests are provided with ears B<sup>2</sup> and, as before remarked, receive steam from the passage A<sup>2</sup>, and the valves B<sup>3</sup> placed in said chests, control the passage of the steam to the ends of the cylinders through ports *b*<sup>2</sup>*b*<sup>2</sup> therein, and provide for the escape of the exhaust-steam from the cylinders through said ports *b*<sup>2</sup>*b*<sup>2</sup> and the ports *b*<sup>3</sup>*b*<sup>3</sup> and *b*<sup>4</sup> in the valves to the exhaust chamber A<sup>4</sup> in the frame by way of passages *b*, as shown in figures 1, 4, 19, and 20.

The engine-cylinders here represented are each provided with a piston and trunk, B<sup>4</sup>, which are connected to the crank shaft by connecting-rods B<sup>5</sup>. These trunks work in stuffing-boxes in the heads C of the cylinders. The connecting-rods are attached to the trunks by means of pins C<sup>1</sup>, journaled in bearings C<sup>2</sup> which are seated in the trunks or pistons as shown. The pins C<sup>1</sup> are prevented from turning in the eyes of the connecting-rods by a feather, *c*, which is fitted in grooves in the pins and eyes.

For the purpose of converting the reciprocating movement of the trunks and pistons into a rotary motion for driving the drill and hoist-drum, there is placed in bearings formed in the upper portions of the standards secured to the bed-plate A, a crank-shaft, D, to the crank D<sup>1</sup>, of which the connecting rods B<sup>5</sup>, are attached. As the thrust of one of the engines is exerted on the crank in a direction at right angles to the thrust of other engine, it will be readily understood that the crank can have no dead point.

Upon the shaft D, is fixed an eccentric, D<sup>2</sup>, as shown in figure 19, its arrangement being such that as it is rotated by the shaft the proper motion is imparted to the valves for causing them to admit steam to the cylinders and exhaust it therefrom at the proper times in the manner heretofore described. This eccentric is provided with straps, *d*, to which are secured rods, *d*<sup>1</sup>, connected at their lower forked ends with the cross-heads, *d*<sup>2</sup>, which slide upon guides, *d*<sup>3</sup>, and to which are secured the valve-rods *d*<sup>3</sup>. The valve-rods are in this instance formed of one piece of metal with the cross-heads.

Keyed to the shaft D, is a geared pinion, D<sup>3</sup>, which meshes into and drives a spur-wheel, E, mounted to revolve on a shaft, *g*; which is supported in standards, G, fixed to the main frame of the machine.

By the side of the spur-wheel E, and moving with it on the same shaft, is placed a drum, E<sup>1</sup>, provided upon its periphery with a groove or grooves for the reception of a rope, which is to lead therefrom to a sheave or pulley placed above it and directly over the hole in the rock, so that when it becomes desirable to lift the drill and its rods from such hole the rope may be attached to the upper end of said rods and the drum put in motion and lift the rods and drill, the swivel-head which carries the drill-rods having first been swung or slid out of the way.

To

*Improvements in Rock-drilling Machine.*

To provide for throwing the hoisting mechanism into and out of operative connection with the driving mechanism, eccentrics,  $g^1$ , are keyed to the drum-shaft  $g$ , said eccentrics being adapted to turn in bearings in the standards  $G$ .

In order to turn the drum-shaft  $g$  and its eccentric to a position which will raise the spur-wheel  $E$  out of mesh with the pinion  $D^3$ , I fix upon one end of said shaft a handle or lever,  $g^2$ , which, when it has raised or lowered the shaft  $g$ , and with it the drum and spur-wheel, is to be locked to the standard  $G$ , by a pin,  $g^3$ , passing through the lever into the standard, suitable holes being provided for this purpose.

By this arrangement the hoisting mechanism can at any time be thrown out of gear without stopping the machine.

At the front end of the crank-shaft is keyed a bevel gear-wheel,  $D^4$ , which meshes into and drives a similarly-bevelled gear-wheel  $F$ . This wheel  $F$  is provided with a sleeve, which rotates in a bearing formed in a bracket projecting outwardly from the swivel-head  $K$  of the machine. The feed-screw  $F^1$  is mounted in and driven by the wheel  $F$ , and to this end both the screw and the sleeve of the wheel are provided with grooves for the reception of a feather, by which they are keyed together. The screw is adapted to move vertically in the sleeve but will be rotated with it. The feed wheels are mounted to turn with the sleeve of wheel  $F$ .

In order that these parts may be better understood, I will describe the same with particular reference to figures 4 to 12 inclusive, in which I have shown the parts on a slightly enlarged scale, and for which I have obtained letters patent of the United States, dated July 13, 1875, number 165,539.

Figure 4 is a front elevation of my improvement; figure 5, a vertical section thereof, taken on the line  $x x$ , figure 4; figure 6, a plan of the roller-bearing and enclosing ring, the upper disc being removed to show the rollers; figure 7, an elevation of the counter or feed shaft; figure 8, a similar elevation of the shipping shaft or plunger, which is within the counter-shaft; figure 9, a horizontal section through the counter-shaft, plunger, and clutch-key; figure 10, a plan of one of the clutch hubs which carry the gear-wheels on the counter-shaft; figure 11, a transverse section of said hubs and gear, taken on the line  $y y$ , figure 10; and figure 12, a horizontal section through the shipping handle, ring, counter-shaft, plunger, and lower key, taken on the line  $z z$ , figure 4.

The same parts are denoted by the same letters in these figures, and this part of the invention consists more particularly in the combination with a revolving rock-drilling machine of a screw-feed and a hydraulic vessel provided with a gauge, whereby the thrust or pressure of the boring bit upon the rock is indicated; also in the combination with a revolving rock-drilling machine of a screw feed and a hydraulic vessel provided with a gauge whereby the weight of the drill-rod is indicated; also, in the adaptation to the aforesaid vessels of a peculiar roller-bearing of my invention; and in the combination, with the differential gearing, of a shipping device, whereby the rate of feed may be changed or the drill withdrawn without stopping the revolution of the drill, all as hereinafter described.

$A$  is the swivel-head, carrying the usual bevel-gear  $B$ , which meshes with the bevel sleeve pinion  $B^1$ , supported by the upper bearing  $D^1$ , and having the hollow screw-shaft  $C$  feathered to it.  $D$  is the chuck, by which the drill-rod is secured to the screw-shaft in the usual manner.  $E$  is the outer, and  $H$  the inner lower bearing, both rigidly secured to the swivel-head by the bolts  $E^1 E^1$ , which pass through both  $E$  and  $H$ .  $F$  is the feed-nut, between which and the bearing  $H$  is a wearing piece or ring,  $f$ , which protects  $H$  from the friction of the feed nut, and may be renewed when worn out. The feed nut is supported or retained in place by two conical roller thrust bearings which receive the thrust of the bit against the rock, or sustain the weight of the rod when in excess of such thrust. Each of these bearings consists of a series of conical rollers,  $G$ , inclosed between a retaining ring,  $h$ , and annular discs or plates,  $a a$ . The rollers, ring, and discs are all made of steel, hardened and finished after tempering by grinding. The rollers and discs are so constructed that the upper line of one roller forms the lower line of the roller diametrically opposite, and the upper line of the latter forms the lower line of the former, as shown in figure 5. Their outer ends have spherical surfaces of much smaller diameter than the diameter of ring,  $h$ , so that only a small portion of the roller is in contact with the ring, and that at the centre of the end where there is least motion, thus reducing the friction and wear of the parts.

The form of the plates  $a a$  is shown in section in figure 5. Their inclined surfaces correspond exactly to those of the rollers, so that the rotation of either of the plates  $a a$  causes the rollers to revolve around the centre of said plates with a true rolling motion, and without slipping or sliding.

The diameter of the ring  $h$  is such that it keeps the rollers in the relative position above described while they do their work. It may be wide enough to cover the rollers either entirely, or, as shown in the drawings, only partially, so that the action of the rollers can be seen while running.

The ring and the discs  $a a$  are not secured to anything, but are free to rotate on the rollers, so that should one of the rollers be broken, it would catch and carry the disc around, thereby preventing injury to the others.

The lower bearing  $H$  is so constructed as to contain two annular hydraulic cylinders,  $e e$ , which may be filled with any suitable liquid. These cylinders are fitted with heavy cup leather packings,  $e^1 e^1$ , which become tighter by increase of pressure on them. In each pair of discs,  $a a$ , one of the said discs is fitted to slide in the cylinder like a piston, and bear upon the packing,  $e^1$ . A pressure-gauge is connected with each cylinder with a pipe,  $d$ , as shown in figure 4.

The gears  $K K K$  which are keyed or feathered to the sleeve gear  $B^1$ , mesh into and drive the gears  $L L L$  on the counter-shaft  $M$ . On the lower end of  $M$  is another gear,  $N$ , which meshes into and drives the gear  $O$  on the feed nut  $F$ , revolving it faster than the screw-shaft  $C$ , which has a left-hand thread, and thereby feeding the bit against the rock. The counter-shaft  $M$  is hollow for part, or all of its length, and is slotted at two different points, as shown in figure 7.

The plunger  $S$  is fitted to the hollow bore of the shaft, so as to slide easily therein. The clutch-key  $g^1$  is secured in a hole in the upper end of the plunger, and passes the upper slot in shaft  $M$ , in which it is free to slide.

The shipping handle  $R$  is secured to the hubs  $u u$ , between which is the ring  $T$ . The key  $K$  is secured in a hole in the lower end of the plunger, and passes through the ring  $T$  and the lower slot in shaft,

*Improvements in Rock-drilling Machine.*

shaft M in which it is free to slide. The ring T thus revolves with the shaft M, but is free to slide vertically upon it. The shipping handle R holds the hubs *u u* from revolving, but allows the shaft M to turn freely in them.

The gear L L L are secured to hubs *m m m*, which are loose on the counter-shaft, and are held in position endwise by the upper bearing D<sup>1</sup>, and the nut *x*<sup>1</sup>. On the inside of the hubs are any suitable number of clutch-jaws to engage with the clutch-key *g* which projects through the counter-shaft on each side.

There is an annular space cut out in the hubs, wide enough for the key *g* and shaft M to remain stationary while the jaws run past without catching on the key, so that in shifting the key from one gear to another it is impossible for it to catch on more than one gear at a time.

Below the gears L L L is a thin hub, W, which rests upon and is secured to the bearing D<sup>1</sup>. The jaws in this are cut in the opposite direction from those in the other hubs, so that when the key *g* is in contact with them they hold the counter-shaft stationary, thereby holding the feed nut stationary likewise.

As the screw-shaft has a left hand thread, and the engine revolves it in a right-hand direction, the effect of holding the nut is to withdraw the bit from the rock. The gears K K K and L L L, as well as the gears N and O, are made with such a number of teeth respectively, as to give a variable feed.

The number of teeth may be so proportioned, for example, that the upper gears K and L shall give an inch of forward movement to every 700 revolutions of the bit, while the middle gears give the same feed to every 450 and the lower gears to every 300 revolutions; but as the production of a variable feed by employing gears with a different number of teeth is well known, I do not describe the details thereof.

There is a rib, *x*<sup>2</sup>, on the swivel-head, with four holes in it, corresponding with a hole in the handle R, so that the position of the clutch-key *g* may be adjusted by means of a bolt or pin passing through the hole in said handle into one of the holes in the rib. If, for example, the handle be secured to the upper hole, the key is in contact with the clutch in the upper gear, giving a feed of one inch to every 700 revolutions. By adjusting the handle to the second or third hole, the key will be brought into contact with the clutch in the middle or lower gear, giving a 450, or 300 feed as the case may be, while by adjusting it to the lowest hole, the key will be brought into contact with the fixed clutch W, so as to lock the feed nut and run the shaft C back.

In order to change the feed in the machine heretofore in use it is necessary to stop the engine, remove the water-joint from the drill rod, take off the gears, replace them by another pair, and then replace the water-joint.

In my improvement the pin may be withdrawn and the handle R shifted, and fixed in position by the pin again while the machine is running, and thus the rate of feed may be changed without stopping the machine, or even reducing its speed.

In operation the thrust of the bit is received upon the lower roller-bearing which transmits it to the packing and liquid in the lower cylinder, and the liquid rising in the pipe *d* to the pressure gauge, indicates the pressure per square inch on the area of the cylinder. The change from one stratum to another of different hardness is thus instantly indicated, and the thickness of each stratum registered without withdrawing the rods to examine and measure the core. After the bit has reached a depth so great that the weight of the rods more than counterbalances the thrust of the bit against the rock, the load will be transferred from the lower roller-bearing to the upper, and the changes of stratums will be indicated by the upper-gauge.

By adjusting the handle R in its lowest position, so as to raise the bit from the bottom of the hole, the engineer can see by a glance at the upper gauge, the exact weight of the rods, and by allowing for that, he can easily calculate the hardness of each stratum.

By means of the gear-shifting mechanism, the rate of feed may be instantaneously adjusted to suit the hardness of the rock indicated by the gauge, thereby preventing injury to the diamonds.

In deep boring, should the pressure suddenly increase without being followed by any change in the colour of the sediment after the proper time has elapsed for the sediment to reach the surface, the engineer will know that the bit is out of order, and that he should withdraw the rod and examine it, so, too, the breaking of the rod will at once be indicated by the gauge.

The swiveled head K which carries the feed-screw F<sup>1</sup>, and its connections, is connected to the frame in such manner and position that the bevel gear D<sup>2</sup> and F, will always be in mesh with each other when the drill is in position for drilling holes, whether such holes are to be drilled in a vertical line or at an angle to a vertical line. To this end the standard H is provided with a ring or flange, H<sup>1</sup>, of which the crank shaft D is the axial centre, upon which flange a plate, I, is seated and can be rotated.

The standard H is provided with four holes, *h*, through which pass bolts, *h*<sup>1</sup>, said bolts passing through corresponding holes, *i*, in the plate I, thus securing it to the standard. This plate I is provided with additional holes in order to admit of its being secured to the standard in the various positions required when drilling holes at an angle to a vertical line.

It is also provided with ears or projections, *i*<sup>1</sup>, in which are formed holes for the reception of a bolt or pintle, *i*<sup>2</sup>, which also passes through lugs, *j*, formed on a yoke, J, thus bringing said yoke to the plate I.

Upon that part of the plate I, which is opposite to the ears or projections, there is formed a slotted lug or projection, *i*<sup>2</sup>, the slot *i*<sup>3</sup> being for the reception of a swinging bolt, *i*<sup>4</sup>, which holds the yoke in its closed position when the drill is being operated.

In front of the plate I is secured a yoke, J, composed of two parts, each one of which is provided at one side with a projection, *j*, through which passes the bolt or pintle, *i*<sup>2</sup>, by which means the yoke is hinged to the plate I, as already stated.

The members of the yoke are at the other side secured by a bolt, *j*<sup>1</sup>, on which the swinging bolt *i*<sup>4</sup> is pivoted.

In the interior surface of the parts composing the yoke there is formed a V shaped groove for the reception of a projection formed on the swivel-head K, consisting of an annular ring, the interior surface of

*Improvements in Rock-drilling Machine.*

of which rests upon the bevelled flange I<sup>1</sup> of the plate I, the portion of the swivel-head K which is held in the V shaped groove of the yoke is formed to fit said groove snugly. The arrangement of these parts is shown in figures 3, 25, 26, and 27.

When it is desired to remove the drill and its rods from the hole that has been drilled, the nut on swinging-bolt  $i^1$  is loosened, and the bolt swung free from the lugs  $i^2$ , and the yoke turned on its hinge, thus moving the yoke and the swivel-head carried thereon out of the path of the drill.

Should it be desired to drill a hole at an angle to a vertical line, the required adjustment is made by removing the bolts  $h^1$ , which secure the plate I to the standard, then rotating said plate on the flange H<sup>1</sup>, until the hinge  $i, j, i^2$ , is substantially parallel with the direction in which the hole is to be drilled, and again securing the plate to the standard H with the bolts  $h^1$ , it will be understood that the holes  $i$ , in the plate I will be sufficient in number and so arranged that said plate may be secured in various positions, in order that the hinge at the side thereof may be practically parallel with the hole to be drilled.

When this adjustment has been made, and the feed-screw and drill are found to be not in the exact position desired, a further adjustment can be made by slacking the nut upon the bolt  $j^1$ , in the yoke J, when the swivel-head K and the parts carried by it may be turned so as to give the required direction to the drill.

The nut on bolt  $j^1$  should then be tightened in order to prevent the swivel-head from turning accidentally.

I have described the method of moving the parts out of the way of the drill and its rods, when they are to be removed from the drilled hole, as being by attaching the parts to a swinging yoke, but it is obvious that a plate or frame adapted to slide upon ways or guides may be substituted therefor, and the parts be slid or moved to one side, a sufficient distance to allow the drill and its rods to be removed without departing from the spirit of my invention.

When the hinged yoke is used for removing the parts out of the way it is important that the hinge shall be parallel or nearly so to the hole being drilled as already described. The feed-screw is connected to the drill rods in the usual or any approved manner.

I have described the drum-shaft  $g$ , as having eccentrics  $g^1$  keyed to it.

It is obvious however that said eccentrics may be formed upon the shaft by casting, and also that a single eccentric may be used at the centre of the drum-shaft without departing from the spirit of my invention, the object of this construction being to adapt the driving gear-wheel of the hoisting apparatus to be readily thrown into or out of mesh with the pinion on the crank-shaft.

Under some circumstances it may be found of advantage to employ the modified construction of swivel-head shown by figures 28 to 30 inclusive, and I would have it understood that I reserve myself the right to the use thereof whenever I find it more advantageous to do so; and for this form of swivel-head, I have also obtained letters patent of the United States under date of August 11th, 1874, number 153,929.

Figure 28 is a front elevation of my improvement; figure 29, a vertical section thereof, taken on the line  $x, x$ , figure 28; and figure 30, a horizontal section taken on the line  $y, y$ , figure 29.

A, represents the front of the main frame which supports the bevel driving-wheel, and in the ordinary machine, the swivel-head. In this improvement it supports the annular swivel-head plate B which is hinged to it by a pin, E, through lugs  $a, a$  and  $b, b$ , on A and B respectively.

On the other side of A are two lugs,  $a^1, a^1$ , through which passes a pin,  $f$ , and on this pin is hinged the bolt F. When the machine is in the position shown in figures 28 and 29, this bolt passes through an open slot in the piece  $b^1$ , projecting from B, and the parts A and B are held together on one side by this bolt and its nut  $f^1$ , which is screwed up tightly against  $b^1$ , and on the other by the hinges already described. By loosening the nut  $f^1$ , and throwing the hinged bolt F, into the position shown in figure 30, so as to clear the nut from the piece  $b^1$ , the plate B is left free to be swung into the position shown in that figure.

There is an annular rib G, on the frame A, turned off perfectly round, and slightly tapering, which when A and B are closed, as shown in figures 28 and 29, fits into an annular recess in B, bored or turned out to correspond exactly with it. C, is the swivel-head made with an annular rib H, fitting exactly into the inner circumference of the plate B, so that the swivel-head carrying the usual screw-shaft for the drill-rod, with bevel pinion thereon; and the usual counter-shaft and feeding gear, is supported on the annular plate B, to which it is secured by the annular clamp DD.

This clamp is made in two pieces, fastened together by bolts and nuts YY, as shown in figure 28, and each of these pieces has an annular groove in its inner surface to receive the inclined faces of the swivel-head and plate.

In operation, the machine being in the position shown in figures 28 and 29, and the nuts YY, being screwed up tightly, the thrust of the drill against the rock when boring is received through the swivel-head and rib H, on the plate B, thereby relieving the clamp DD and is then transmitted, through the rib G, and its corresponding recess, to the frame A, so as to relieve the hinges and hinged bolt F, the entire thrust of the drill or weight of the rod, as the case may be, is thus sustained by the frame. When the angle of drilling is to be changed, the operator loosens either one of the nuts YY, which permits the swivel-head to be turned on the plate B.

Having adjusted the swivel-head in the desired position, he tightens the nut again, and the drilling proceeds.

When the drill-rod is to be withdrawn from the hole, the operator raises it in the usual manner until he can uncouple the joint below the chuck.

After uncoupling he raises the upper section of the pipe clear of the lower, and tightens the chuck again. Next he loosens the nut  $f^1$  till he can throw the bolt F into the position shown in figure 30, after which he swings the plate B on its hinges into the position shown in said figure, thus leaving the front of the machine clear, and allowing free passage for the block and tackle lifting-jack, &c.

Having now described the nature of the said invention, and the manner in which the same may be carried into practical effect, what I claim and desire to secure by letters of registration, is:—

- 1st. In a rock-drilling machine the combination, substantially as before set forth, of the front standard provided with a ring flange, the plate seated and adapted to be rotated on said flange, and the movable yoke, the parts being so arranged that the yoke carrying the swivel-head and its attachments can be moved out of the way of the drill when the latter is to be withdrawn from the drilled hole.

*Improvements in Rock-drilling Machine.*

- 2nd. In a rock-drilling machine, the combination, substantially as before set forth, of a pair of trunk engines arranged at right angles to each other, and operating a crank common to both engines, the crank-shaft, the hoist-rig, arranged above said shaft, and the feed screw for operating the drill.
- 3rd. In a rock-drilling machine, the combination, substantially as before set forth, of the crank-shaft, the hoist-drum mounted to revolve on the drum-shaft, motion transmitting mechanism, and the eccentrics on the drum shaft.
- 4th. In a rock-drilling machine, the combination, substantially as before set forth, of the front standard, provided with a ring-flange, the swivel-head, the hinged yoke, and the plate to which the yoke is hinged, said plate being adapted to be turned so as to change the position of the hinge.
- 5th. The combination, substantially as described of a revolving rock-drill, a screw feed, and a hydraulic vessel provided with a gauge, whereby the pressure of the bit upon the rock is indicated.
- 6th. The combination, substantially as described, of a revolving rock-drill, a screw-feed, and a hydraulic vessel provided with a gauge, whereby the weight of the drill-rod is indicated.
- 7th. The combination with the discs *a a*, and retaining ring *h*, of the conical rollers *GG*, constructed without journals, and whose outer bases are spherical surfaces of less radius than that of the retaining ring.
- 8th. The combination with the hydraulic cylinder *e*, of the roller *G*, and discs *a a*, one of which is fitted to slide in said cylinder like a piston, substantially as described.
- 9th. The combination with the screw-shaft and feed-nut, of the gears which feed said shaft at different rates of speed, and the shipping mechanism whereby the rate of feed may be changed without stopping the revolution of the drill.
- 10th. The combination with the hubs *m m m*, and gears *L L L*, of the slotted counter-shaft *M*, plunger *S*, keys *g*<sup>1</sup>, and *K*, shipping handle *R*, hubs *u u*, and ring *T*, operating as and for the purpose described.
- 11th. The combination, substantially as described, of the fixed hub *W*, and the shipping mechanism.
- 12th. The combination, substantially as described, of the main frame of a rock-drilling machine and a swivel attachment hinged thereto and supporting the drill-rod.
- 13th. The combination, substantially as described, with the main frame of a rock-drilling machine and a swivel attachment hinged thereto, and supporting the drill rod of the locking-bolt *F*.
- 14th. The combination, substantially as described, of the frame *A*, constructed with a rib *G*, and the correspondingly recessed swivel-head plate *B*.
- 15th. The combination, substantially as described, of the swivel-head plate *B* and ribbed swivel-head *C*.
- 16th. The combination, substantially as described, of the plate *B*, swivel-head *C*, and clamp *DD*.
- 17th. The combination of the main frame, swivel-head plate, swivel-head and clamp, all arranged and operating, substantially as shown and described.

In witness whereof, I, the said Milan Constant Bullock, have hereunto set my hand and seal, this ninth day of September, in the year of Our Lord one thousand eight hundred and eighty-two.  
MILAN CONSTANT BULLOCK.

This is the specification marked "A" referred to in the annexed Letters of Registration granted to Milan Constant Bullock, this twelfth day of February, A.D. 1883.

AUGUSTUS LOFTUS.

---

REPORT.

Sir,

In accordance with your letter of the 5th December, we have examined the specification and plans attached to the application of Milan Constant Bullock, for protection for an invention entitled "Improvement in Rock-drilling Machines," and have to report that we see no reason why the protection sought should not be granted.

Sydney, 14 December, 1882.  
We have, &c.,  
JAMES BARNET.  
WILLIAM C. BENNETT.

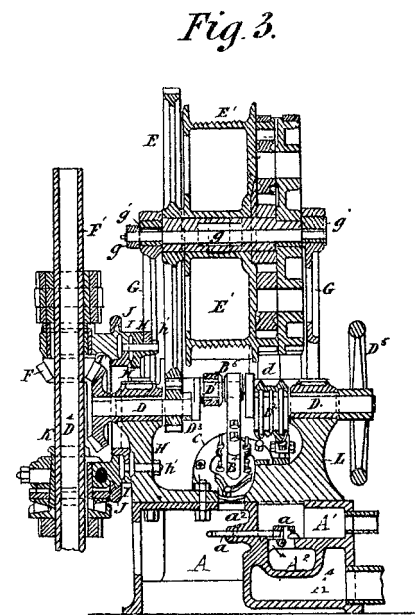
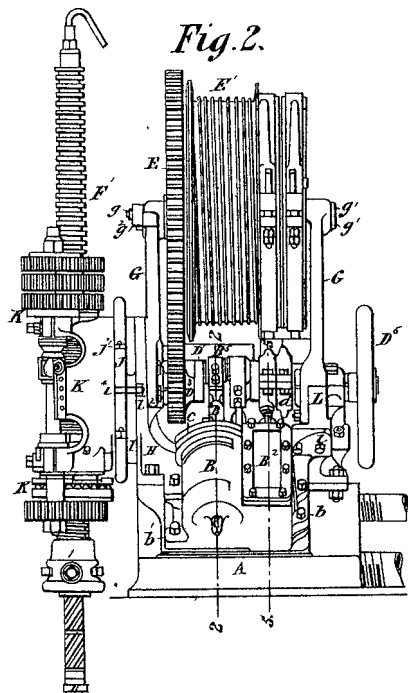
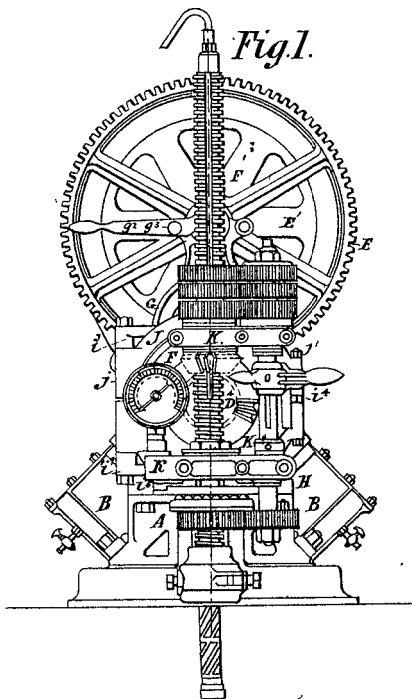
The Under Secretary of Justice.

---

[Drawings—three sheets.]

No. 1196.

[Assignment of No. 710. See Letters of Registration for 1878, page 153.]



*This is the Sheet of Drawings marked B. referred to in the annexed Letters of Registration granted to Milan Constant Bullock this twelfth day of February A. D. 1883.*

*Augustus Loftus.*

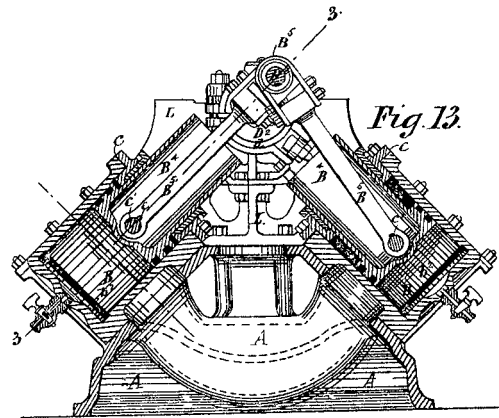


Fig. 13.

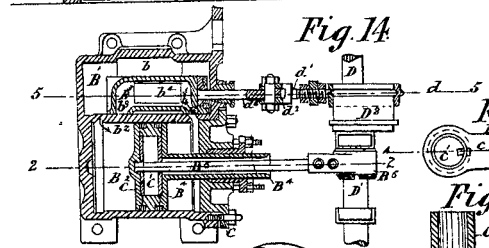


Fig. 14.

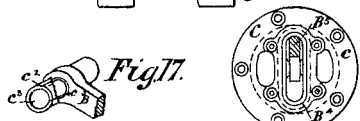


Fig. 17.

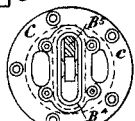


Fig. 18.

Fig. 15.

Fig. 16.

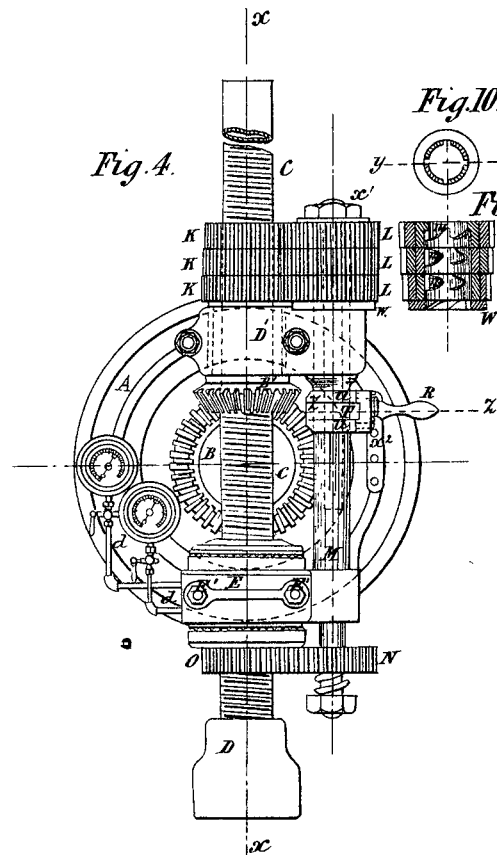


Fig. 4.

Fig. 10.

Fig. 11.

Fig. 8.

Fig. 9.

Fig. 7.

Fig. 5.

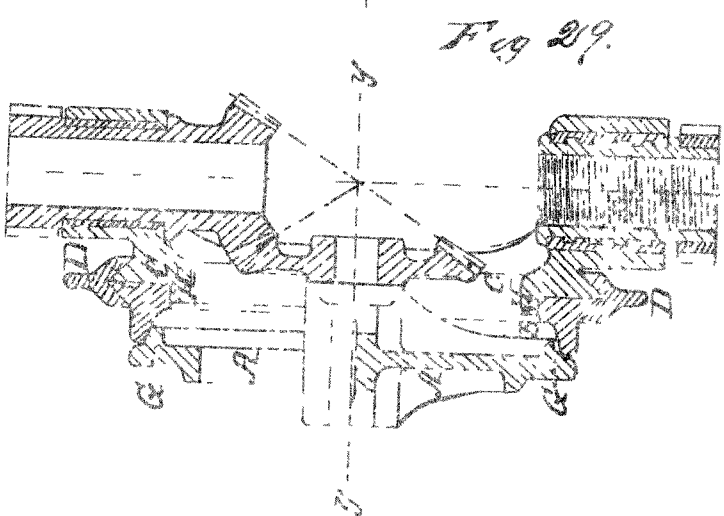
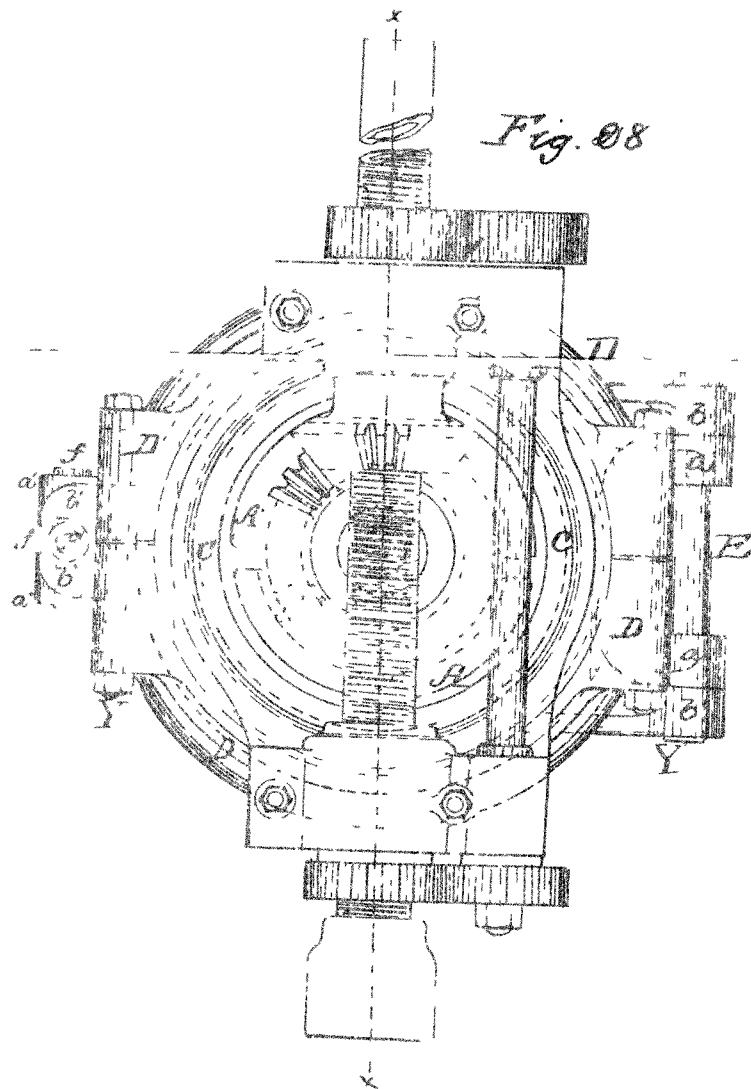
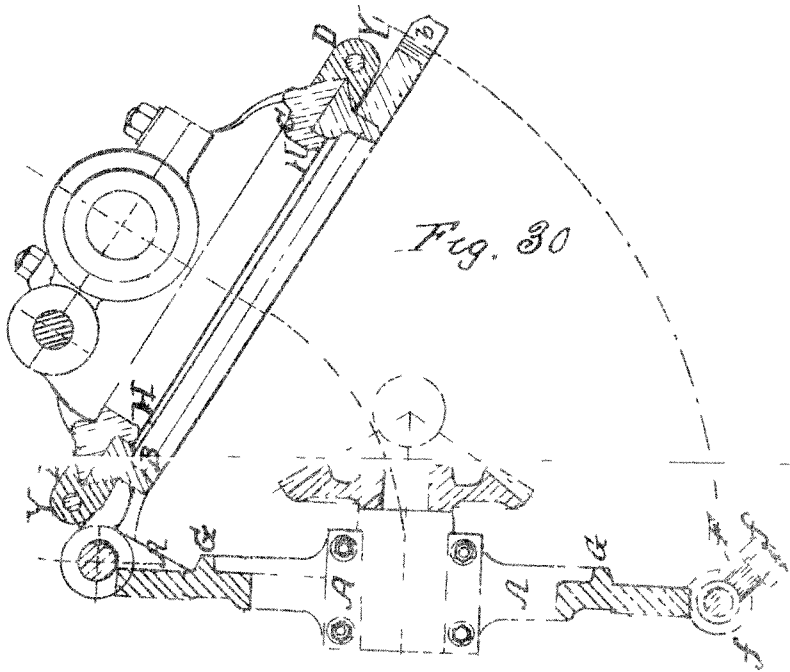
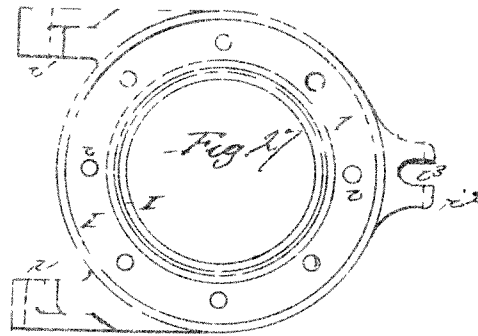
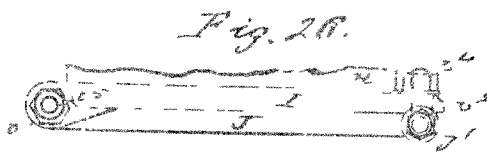
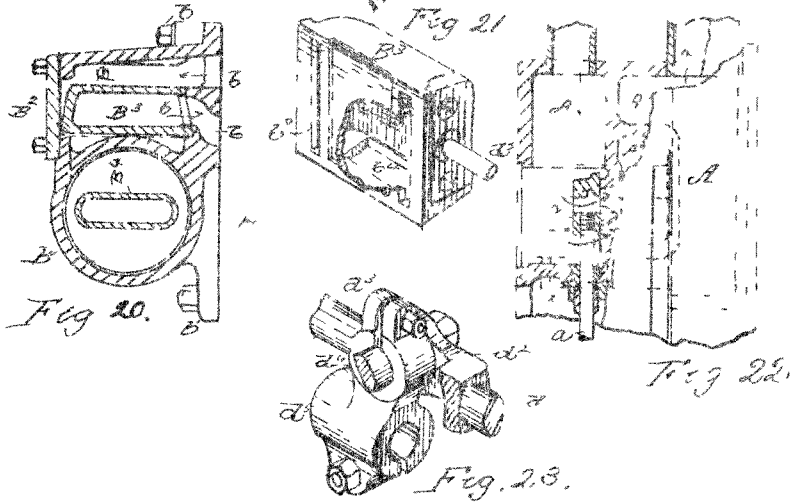
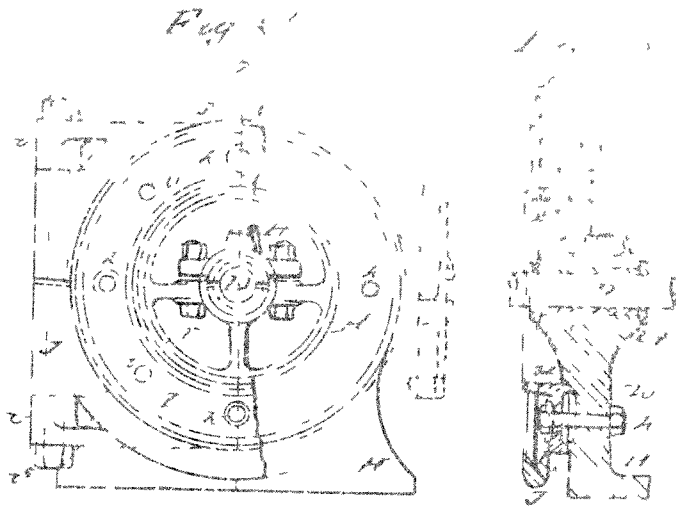
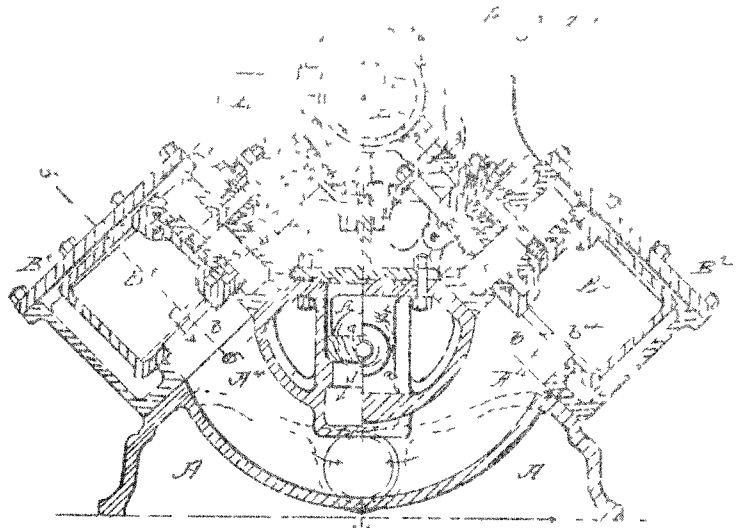
Fig. 6.

Fig. 12.

This is the Sheet of Drawings marked C. referred to in the annexed Letters of Registration granted to Milan Constant Bullock this twelfth day of February A. D. 1883.

Augustus Loftus.

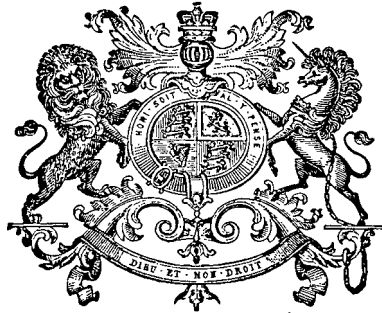




This is the sheet of drawings made in accordance with the annexed letters of Registration, granted to George Eastman, Buffalo, New York, on the 11th day of February, A.D. 1871.

George Eastman.





A.D. 1883, 23rd February. No. 1197.

IMPROVEMENT IN HYDRAULIC LIFTING MACHINES.

LETTERS OF REGISTRATION to Edward William Cracknell, for an Improvement in Hydraulic Lifting Machines.

[Registered on the 24th day of February, 1883, in pursuance of the Act 16 Vic. No. 24.]

BY HIS EXCELLENCY THE RIGHT HONORABLE SIR AUGUSTUS WILLIAM FREDERICK SPENCER LOFTUS (commonly called LORD AUGUSTUS LOFTUS), Knight Grand Cross of the Most Honorable Order of the Bath, a Member of Her Majesty's Most Honorable Privy Council, Governor and Commander-in-Chief of the Colony of New South Wales and its Dependencies.

TO ALL TO WHOM THESE PRESENTS SHALL COME, greeting :

WHEREAS EDWARD WILLIAM CRACKNELL, consulting engineer and architect, of 257, George-street, Sydney, hath by his Petition humbly represented to me that he is the author or designer of a certain invention or improvement in manufactures, that is to say, of an invention entitled "An Improvement in Hydraulic Lifting Machines," which is more particularly described in the specification and the sheet of drawings which are hereunto annexed ; and that he, the said Petitioner, hath deposited with the Honorable the Treasurer of the said Colony of New South Wales the sum of Twenty Pounds sterling, for defraying the expense of granting these Letters of Registration, as required by the Act of Council, sixteenth Victoria, number twenty-four, and hath humbly prayed that I would be pleased to grant Letters of Registration, whereby the exclusive enjoyment and advantage of the said invention or improvement might be secured to him for a period of fourteen years : And I, being willing to give encouragement to all inventions and improvements in the arts or manufactures which may be for the public good, and having received a report favourable to the prayer of the said Petition, from competent persons appointed by me to examine and consider the matters stated therein, and to report thereon for my information, am pleased, with the advice of the Executive Council, and in exercise of the power and authority given to me by the said Act of Council, to grant, and do by these Letters of Registration grant unto the said Edward William Cracknell, his executors, administrators, and assigns, the exclusive enjoyment and advantage of the said invention or improvement, for and during the term of fourteen years from the date hereof ; to have, hold, and exercise unto the said Edward William Cracknell, his executors, administrators, and assigns, the exclusive enjoyment and advantage thereof, for and during and unto the full end and term of fourteen years from the date of these presents next and immediately ensuing, and fully to be complete and ended : Provided always, that if the said Edward William Cracknell shall not, within three days after the granting of these Letters of Registration, register the same in the proper Office in the Supreme Court, at Sydney, in the said Colony of New South Wales, then these Letters of Registration, and all advantages whatsoever hereby granted, shall cease and become void.

In witness whereof, I have hereunto set my sign manual, and have caused the present Letters of Registration to be sealed with the seal of the said Colony of New South Wales, at Government House, Sydney, in New South Wales, this twenty-third day of February, in the year of our Lord one thousand eight hundred and eighty-three.

[L.S.]

AUGUSTUS LOFTUS.

---

*Improvement in Hydraulic Lifting Machines.*

---

SPECIFICATION of EDWARD WILLIAM CRACKNELL, consulting engineer and architect, of 257, George-street, Sydney, for an invention entitled "An Improvement in Hydraulic Lifting Machines."

It consists of a ram having a pulley on the outer end, working in a cylinder with drums attached as hereinafter described.

Figure 1 shows a section through the machine.

Figure 2 is the plan.

Figure 3 is the front elevation.

A is a ram which works in the cylinder B, and is fitted with a pulley C on the outer end, over which a chain belt or rope passes, having one end fixed and the other wound round the small drum D, which is fixed to the shaft E, to which the lift drum F is attached.

This lift is worked by water or other fluid being admitted to the cylinder B, by a valve-cock or other suitable device, which forces the ram A out, and thus causes the chain, belt, or rope, to turn the drum D, which also turns the drum F, on which the lift-rope winds; thus with a short-stroke ram, a high lift can be worked with very little loss of power by friction, for by passing the chain-belt or rope over the pulley on the ram by which a gain of two to one is effected, the rest of the multiplying is done by the difference between the diameters of the drums D and F.

I claim the following advantages, which are possessed by this machine—

First—There is no chain in the water, and all working parts can easily be seen, and replaced if required.

Second—There is very little power lost by friction, as the multiplying is chiefly done by the difference between the diameters of the drums D and F.

Third—The construction is very simple, and the cylinder will only require boring near the gland. The ram can be more easily kept tight than a piston.

Fourth—This machine can work in a horizontal, vertical, or any other position, and the drums D and F may be fixed on either side, or at the end of the ram.

Fifth—A fair lead can be given to the chain belt or rope by providing the pulley at the top of the ram with a swivel, or by making the drum D traverse along the shaft E, which would then be fitted with a feather, or other suitable attachment, which would prevent it from slipping round the shaft E.

Dated at Sydney, this nineteenth day of December, A.D. 1882.

E. W. CRACKNELL.

This is the specification referred to in the annexed Letters of Registration granted to Edward William Cracknell, this twenty-third day of February, A.D. 1883.

AUGUSTUS LOFTUS.

---

REPORT.

---

Sir,

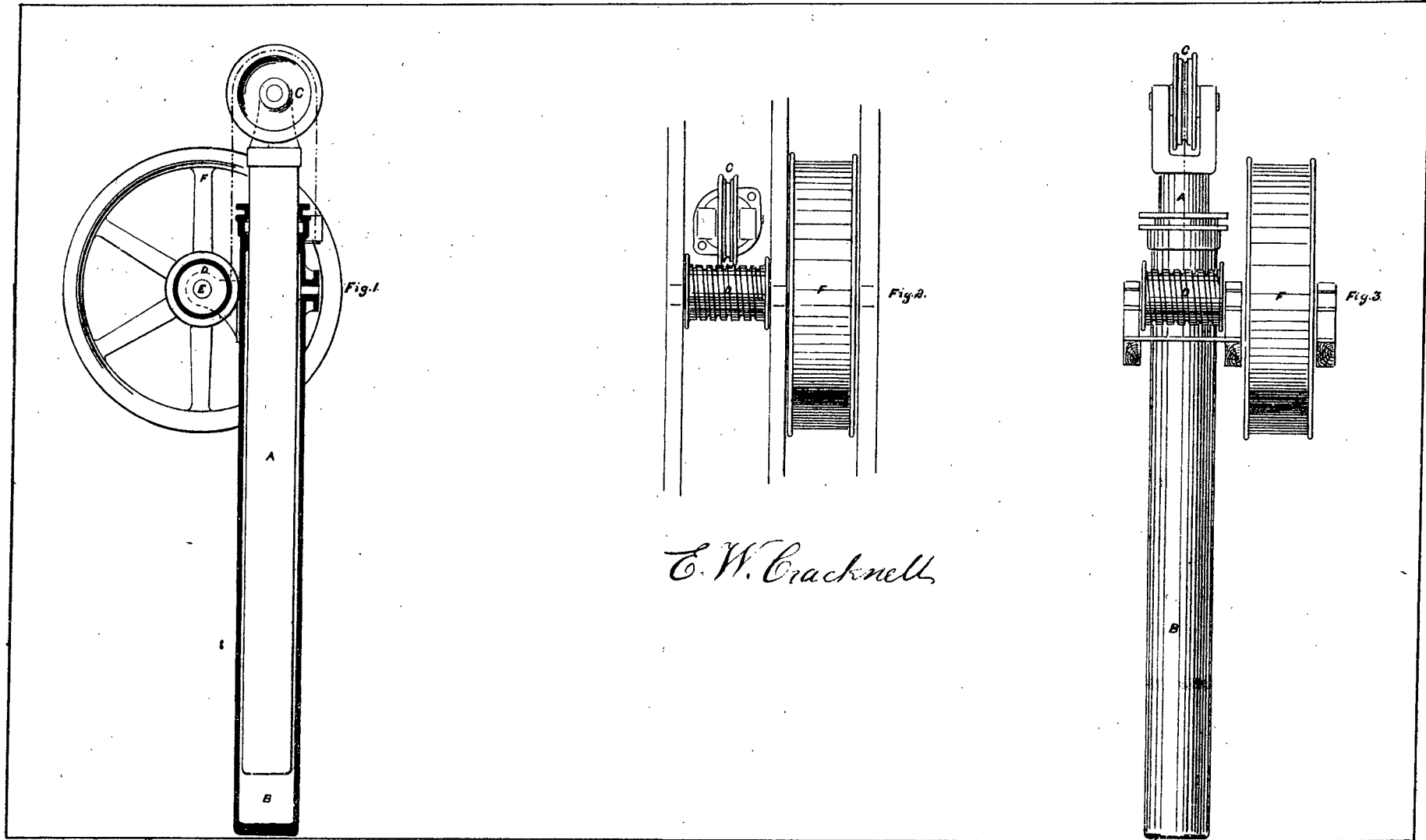
Sydney, 3 January, 1883.

The application of Mr. Edward William Cracknell, for Letters of Registration for "An Improvement in Hydraulic Lifting Machines," having been referred to us, we have examined the plans and specification accompanying the same, and have now the honor to report that we see no objection to the issue of Letters of Registration as prayed for.

We have, &c.,

JAMES BARNET.  
E. O. MORIARTY.

The Under Secretary of Justice.



*E. W. Cracknell*

*This is the Sheet of Drawings referred to in the annexed  
 Letters of Registration granted to Edward William  
 Cracknell, this twenty third day of February AD. 1883.  
 Augustus Loftus.*



A.D. 1883, 23rd February. No. 1198.

A MACHINE FOR GENERATING THE ELECTRIC CURRENT OR FOR USE AS  
AN ELECTRO-MOTOR.

LETTERS OF REGISTRATION to James Hamilton Fraser, for an invention entitled A Machine for Generating the Electric Current, or for use as an Electro-Motor.

[Registered on the 24th day of February, 1883, in pursuance of the Act 16 Vic. No. 24.]

BY HIS EXCELLENCY THE RIGHT HONORABLE SIR AUGUSTUS WILLIAM FREDERICK SPENCER LOFTUS (commonly called LORD AUGUSTUS LOFTUS), Knight Grand Cross of the Most Honorable Order of the Bath, a Member of Her Majesty's Most Honorable Privy Council, Governor and Commander-in-Chief of the Colony of New South Wales and its Dependencies.

TO ALL TO WHOM THESE PRESENTS SHALL COME, greeting :

WHEREAS JAMES HAMILTON FRASER, of 41, Collins-street, Melbourne, Victoria, engineer, hath by his Petition humbly represented to me that he is the author or designer of a certain invention or improvement in manufactures, that is to say, of an invention entitled "A Machine for Generating the Electric Current, or for use as an Electro-Motor," which is more particularly described in the specification which is hereunto annexed; and that he, the said Petitioner, hath deposited with the Honorable the Treasurer of the said Colony of New South Wales the sum of Twenty Pounds sterling, for defraying the expense of granting these Letters of Registration, as required by the Act of Council, sixteenth Victoria, number twenty-four; and hath humbly prayed that I would be pleased to grant Letters of Registration, whereby the exclusive enjoyment and advantage of the said invention or improvement might be secured to him for a period of fourteen years: And I, being willing to give encouragement to all inventions and improvements in the arts or manufactures which may be for the public good, and having received a report favourable to the prayer of the said Petition, from competent persons appointed by me to examine and consider the matters stated therein, and to report thereon for my information, am pleased, with the advice of the Executive Council, and in exercise of the power and authority given to me by the said Act of Council, to grant, and do by these Letters of Registration grant unto the said James Hamilton Fraser, his executors, administrators, and assigns, the exclusive enjoyment and advantage of the said invention or improvement, for and during the term of fourteen years from the date hereof; to have, hold, and exercise unto the said James Hamilton Fraser, his executors, administrators, and assigns, the exclusive enjoyment and advantage thereof, for and during and unto the full end and term of fourteen years from the date of these presents next and immediately ensuing, and fully to be complete and ended: Provided always, that if the said James Hamilton Fraser shall not, within three days after the granting of these Letters of Registration, register the same in the proper office in the Supreme Court, at Sydney, in the said Colony of New South Wales, then these Letters of Registration, and all advantages whatsoever hereby granted, shall cease and become void.

In witness whereof, I have hereunto set my sign manual, and have caused the present Letters of Registration to be sealed with the seal of the said Colony of New South Wales, at Government House, Sydney, in New South Wales, this twenty-third day of February, in the year of our Lord one thousand eight hundred and eighty-three.

[L.S.]

AUGUSTUS LOFTUS.

---

*A Machine for Generating the Electric Current or for use as an Electro-Motor.*

---

SPECIFICATION of JAMES HAMILTON FRASER, of 41, Collins-street, Melbourne, Victoria, engineer, for an invention entitled "A Machine for Generating the Electric Current or for use as an Electro-Motor."

My invention consists of a metal disc, revolving on its axis between magnets, so disposed as to enclose the disc in a magnetic field of uniform intensity, the current being taken from the hub and the rim.

It has been known for a long time that a current of electricity is generated in a disc revolving between the poles of a magnet, but hitherto nearly the whole of the current has been wasted in the disc itself in local currents, which absorbed a large amount of work and heated the disc to a great extent, thus rendering the disc useless as a practical machine for generating the electric current. By enclosing the whole of the disc in a magnetic field, uniform entirely round it, the formation of local currents is rendered impossible, and the whole of the work done in revolving the disc is converted into a useful external current, while the disc remains perfectly cool.

I claim, as the novelty of my invention, the use of a metal disc, revolving on its axis between magnets, so disposed as to enclose the disc in a magnetic field, uniform entirely round the disc, thus rendering the formation of local currents impossible.

For currents of higher electro-motive force, a number of discs, parallel to one another and insulated from each other, revolve between magnets as aforesaid, the current being taken from the rim of one disc by means of brushes or other suitable devices, and sent into the hub of the next by means of brushes or suitable devices, and so on, the current for external use being taken from the hub of the first and the rim of the last disc.

For currents of higher electro-motive force, the disc or discs may be divided into a number of sectors insulated from each other, a corresponding number of brushes being set round the rim, and also round the hub, the rim-brush of one sector being connected to the hub-brush of the next, and so on, the current for external use being taken from the rim-brush of the first and the hub-brush of the last.

The magnets are annular in form, and are excited by either a direct current or by a shunt current, or they may be permanent magnets.

This is the specification referred to in the annexed Letters of Registration granted to James Hamilton Fraser, this 23rd day of February, A.D. 1883.

AUGUSTUS LOFTUS.

---

REPORT.

Sir,

Sydney, 28 December, 1882.

We do ourselves the honor to report, in reply to your blank cover communication of the 18th instant, No. 13,929, transmitting James Hamilton Fraser's Petition for the registration of an invention entitled "A Machine for Generating the Electric Current or for use as an Electro-Motor," that we are of opinion the prayer of the Petitioner may be granted in terms of his specification, drawing, and claim.

We have, &c.,

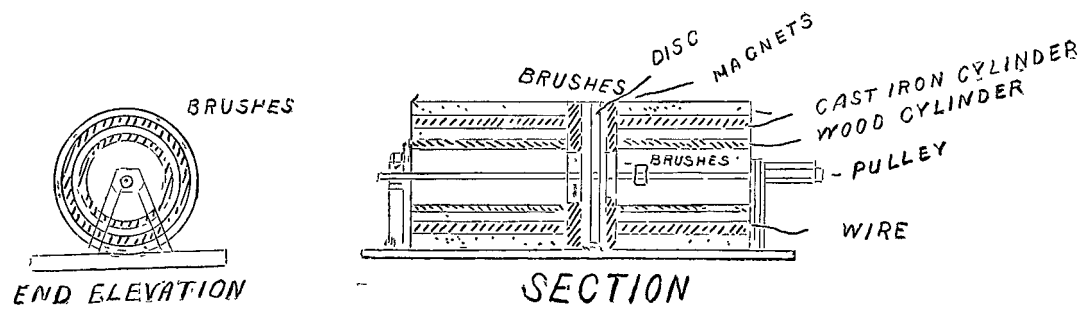
E. C. CRACKNELL.  
GOTHER K. MANN.

The Under Secretary of Justice.

---

[Drawings—one sheet.]

JAMES HAMILTON FRAZER.





A.D. 1883, 23rd February. No. 1199.

A NEW OR IMPROVED DYNAMO-ELECTRIC OR ELECTRO-DYNAMIC MACHINE.

LETTERS OF REGISTRATION to Paul Jablochkoff, for an invention entitled  
A New or Improved Dynamo-electric or Electro-dynamic Machine.

[Registered on the 24th day of February, 1883, in pursuance of the Act 16 Vic. No. 24.]

BY HIS EXCELLENCY THE RIGHT HONORABLE SIR AUGUSTUS WILLIAM FREDERICK SPENCER LOFTUS  
(commonly called LORD AUGUSTUS LOFTUS), Knight Grand Cross of the Most Honorable Order of  
the Bath, a Member of Her Majesty's Most Honorable Privy Council, Governor and Commander-  
in-Chief of the Colony of New South Wales and its Dependencies.

TO ALL TO WHOM THESE PRESENTS SHALL COME, greeting :

WHEREAS PAUL JABLOCHKOFF, of Paris, in the Republic of France, engineer, hath by his  
Petition humbly represented to me that he is the author or designer of a certain invention or improvement  
in manufactures, that is to say, of an invention entitled "A new or improved Dynamo-electric or Electro-  
dynamic Machine," which is more particularly described in the specification and the sheet of drawings  
which are hereunto annexed ; and that he, the said Petitioner, hath deposited with the Honorable the  
Treasurer of the said Colony of New South Wales the sum of Twenty Pounds sterling, for defraying the  
expense of granting these Letters of Registration, as required by the Act of Council, sixteenth Victoria,  
number twenty-four ; and hath humbly prayed that I would be pleased to grant Letters of Registration,  
whereby the exclusive enjoyment and advantage of the said invention or improvement might be secured  
to him for a period of fourteen years : And I, being willing to give encouragement to all inventions and  
improvements in the arts or manufactures which may be for the public good, and having received a  
report favourable to the prayer of the said Petition, from competent persons appointed by me to examine  
and consider the matters stated therein and to report thereon for my information, am pleased, with the  
advice of the Executive Council, and in exercise of the power and authority given to me by the said Act  
of Council, to grant, and do by these Letters of Registration grant, unto the said Paul Jablochkoff, his  
executors, administrators, and assigns, the exclusive enjoyment and advantage of the said invention or  
improvement, for and during the term of fourteen years from the date hereof ; to have, hold, and exercise  
unto the said Paul Jablochkoff, his executors, administrators, and assigns, the exclusive enjoyment and  
advantage thereof, for and during and unto the full end and term of fourteen years from the date of  
these presents next and immediately ensuing, and fully to be complete and ended : Provided always,  
that if the said Paul Jablochkoff shall not, within three days after the granting of these Letters of  
Registration, register the same in the proper office in the Supreme Court at Sydney, in the said Colony of  
New South Wales, then these Letters of Registration, and all advantages whatsoever hereby granted, shall  
cease and become void.

In witness hereof, I have hereunto set my sign manual, and have caused the present Letters of  
Registration to be sealed with the seal of the said Colony of New South Wales, at Govern-  
ment House, Sydney, in New South Wales, this twenty-third day of February, in the year of  
our Lord one thousand eight hundred and eighty-three.

[L.S.]

AUGUSTUS LOFTUS.

*A new or improved Dynamo-electric or Electro-dynamic Machine.*

SPECIFICATION of PAUL JABLOCHKOFF, of Paris in the Republic of France, engineer, for an invention entitled "A new or improved Dynamo-electric or Electro-dynamic Machine."

THIS invention relates to the construction and arrangement of dynamo-electric or electro-dynamic machines in a simple form, the leading feature of which is the obliquity of the polar field to the axis of rotation as the ecliptic is inclined to the earth's axis. Machines presenting this feature may be arranged in various ways, some of which I will describe, referring to the accompanying drawings.

Figure 1 is a diagram showing a simple form of machine. A bobbin, A, having cheeks, *a* *b*, of soft iron, and wound with a coil of insulated wire, is fixed obliquely on an axis, O, and revolves between the poles of two electro-magnets, N and S. The obliquity of the bobbin is such that in each revolution it presents the edges of *a* and *b* alternately to the poles of N and S and the cheeks, *a* and *b*, having their induced polarity thus alternated, alternating electric currents are set up in the coil of A. Figure 2 shows a construction in which the bobbin, B, fixed obliquely on the axis, O, revolves within an oblique bobbin, C, which has an iron sheath, F, presenting interior polar edges towards the edges of B. The electric currents generated in the coil of B are collected and converted into currents of uniform direction by means of a commutator, D, of ordinary construction.

In the construction shown in figure 3 the exterior bobbin, C, is of soft iron, constituting a solenoid. The commutator, D, may be applied as shown to alternate the currents in the coil of C, those in the coil of B being constant in direction, collected in the usual way by rubbers bearing on rings at E. In this case, the internal bobbin, C, need not be of soft iron. When the machine is of large diameter the interior bobbin, A, may be as shown in figure 4, merely a ring of iron fixed on a wheel of non-magnetic material.

Obviously machines constructed and arranged as above described may be employed either as dynamo-electric machines, converting motive power into electricity, or as electro-dynamic machines, converting electricity into motive power. They present the advantage of great simplicity of construction, and they require no nice adjustments.

Having thus described the nature of my invention and in what manner the same is to be performed, I claim:—

A dynamo-electric or electro-dynamic machine, wherein a magnetic coiled bobbin revolves between or within polar fields, the bobbin being fixed obliquely on its axis so as to present its opposite edges to opposite fields alternately in each revolution, substantially as herein described.

In witness whereof, I, the said Paul Jablochhoff, have hereunto set my hand and seal, this first day of November, in the year of our Lord one thousand eight hundred and eighty-two.

PAUL JABLOCHKOFF.

Witness—

CHARLES MARDEBT,  
Civil Engineer, of Paris, 3 rue de Valenciennes.

This is the specification referred to in the annexed Letters of Registration granted to Paul Jablochhoff, this 23rd day of February, A.D. 1883.

AUGUSTUS LOFTUS.

REPORT.

Sir,

Sydney, 27 December, 1882.

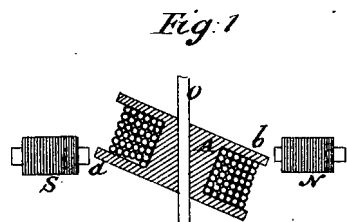
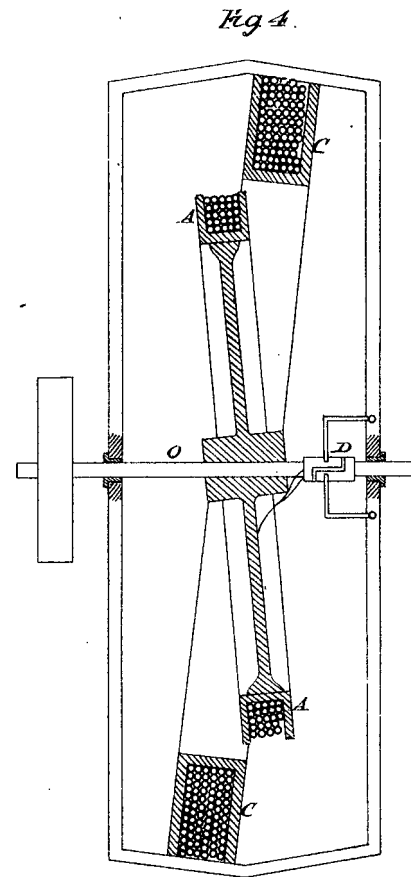
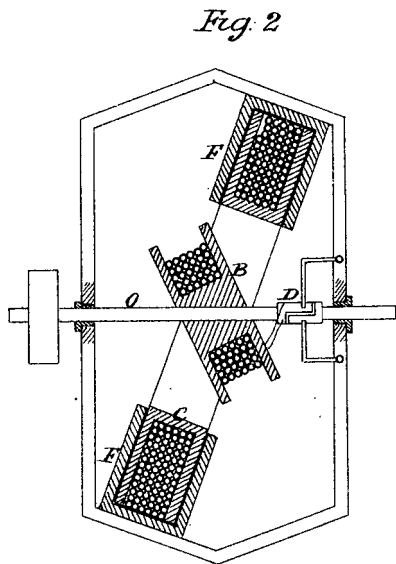
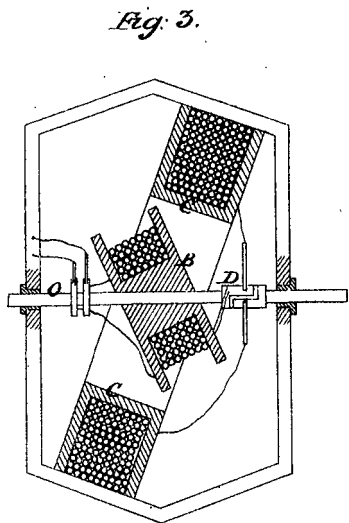
We do ourselves the honor to report, in reply to your blank cover communication of the 19th instant, No. 13,947, that we are of opinion Letters of Registration may be granted in favour of Mr. Paul Jablochhoff for an invention entitled "A new and improved Dynamo-electric or Electro-dynamic Machine," in terms of his petition, specification, drawings, and claim.

We have, &c.,

E. C. CRACKNELL.  
GOTHER K. MANN.

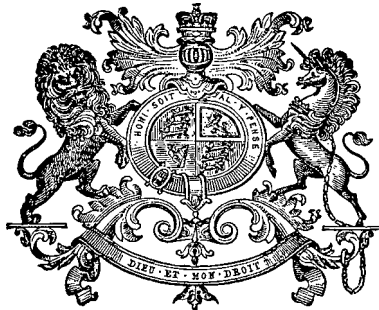
The Under Secretary of Justice.





*This is the Sheet of Drawings referred to in the annexed  
Letters of Registration granted to Paul Jablockhoff  
this 23<sup>rd</sup> day of February A. D. 1883.*

*Augustus Loftus.*



A.D. 1883, 23rd February. No. 1200.

**IMPROVEMENTS IN REFRIGERATING AND FREEZING, AND IN APPARATUS  
EMPLOYED FOR SUCH PURPOSES.**

LETTERS OF REGISTRATION to John Chambers for an invention entitled  
Improvements in Refrigerating and Freezing, and in Apparatus employed for  
such purposes.

[Registered on the 24th day of February, 1883, in pursuance of the Act 16 Vic. No. 24.]

BY HIS EXCELLENCY THE RIGHT HONORABLE SIR AUGUSTUS WILLIAM FREDERICK SPENCER LOFTUS  
(commonly called LORD AUGUSTUS LOFTUS), Knight Grand Cross of the Most Honorable Order of  
the Bath, a Member of Her Majesty's Most Honorable Privy Council, Governor and Commander-in-  
Chief of the Colony of New South Wales and its Dependencies.

TO ALL TO WHOM THESE PRESENTS SHALL COME, greeting :

WHEREAS JOHN CHAMBERS, of Te Mata, Napier, New Zealand, at present residing at Man-  
chester, in the County of Lancaster, England, hath by his Petition humbly represented to me that he is  
the author or designer of a certain invention or improvement in manufactures, that is to say, of an inven-  
tion entitled "Improvements in Refrigerating and Freezing, and in Apparatus employed for such pur-  
poses," which is more particularly described in the specification and the sheet of drawings which are hereunto  
annexed; and that he, the said Petitioner, hath deposited with the Honorable the Treasurer of the said  
Colony of New South Wales the sum of Twenty Pounds sterling, for defraying the expense of granting  
these Letters of Registration, as required by the Act of Council, sixteenth Victoria, number twenty-  
four; and hath humbly prayed that I would be pleased to grant Letters of Registration, whereby the  
exclusive enjoyment and advantage of the said invention or improvement might be secured to him for a  
period of fourteen years: And I, being willing to give encouragement to all inventions and improve-  
ments in the arts and manufactures which may be for the public good, and having received a report  
favourable to the prayer of the said Petition, from competent persons appointed by me to examine and  
consider the matters stated therein and to report thereon for my information, am pleased, with the  
advice of the Executive Council, and in exercise of the power and authority given to me by the said Act of  
Council, to grant, and do by these Letters of Registration grant unto the said John Chambers, his execu-  
tors, administrators, and assigns, the exclusive enjoyment and advantage of the said invention or  
improvement, for and during the term of fourteen years from the date hereof; to have, hold, and  
exercise unto the said John Chambers, his executors, administrators, and assigns, the exclusive enjoyment  
and advantage thereof, for and during and unto the full end and term of fourteen years from the date  
of these presents next and immediately ensuing, and fully to be complete and ended: Provided always,  
that if the said John Chambers shall not, within three days after the granting of these Letters of  
Registration, register the same in the proper office in the Supreme Court, at Sydney, in the said Colony  
of New South Wales, then these Letters of Registration, and all advantages whatsoever hereby granted,  
shall cease and become void.

In witness whereof, I have hereunto set my sign manual, and have caused the present Letters  
of Registration to be sealed with the seal of the said Colony of New South Wales, at  
Government House, Sydney, in New South Wales, this twenty-third day of February, in  
the year of our Lord one thousand eight hundred and eighty-three.

[L.S.]

AUGUSTUS LOFTUS.

*Improvements in Refrigerating and Freezing, &c.*

SPECIFICATION of JOHN CHAMBERS, of Te Mata, Napier, New Zealand, at present residing at Manchester, in the County of Lancaster, England, for an invention entitled "Improvements in Refrigerating and Freezing, and in Apparatus employed for such purposes."

The principal object of this invention is to provide an improved and inexpensive means for preserving meat during its transport on board ship from one country to another, but the same process and apparatus are equally applicable to the transmission of cold for other refrigerating or freezing purposes.

I propose to produce the cold in the first place by means of the vaporization of any of the well known condensible gases ordinarily employed for this purpose, such as sulphurous-oxide, ammonia, and others, or by any other suitable cooling or freezing medium, and for transmitting this cold to the cooling or freezing chamber or room I employ a current of air, which I cause by means of a fan, blower, or air-compressor to pass through the refrigerator, or refrigerators, where it becomes cooled or frozen by the action of the cooling or freezing medium employed, and then passes on direct to the cooling or freezing chamber or room.

The air passes through the fan, blower, or compressor, and after being refrigerated or frozen is admitted into a tube or trunk (preferably of wood) extending (by preference) along the bottom of the cooling or freezing chamber or room, and provided with perforations at the sides, whereby the cooled or frozen air passes into the chamber or room.

At or near the top of the latter is a similar perforated trunk leading to the centre of the fan or blower, or to the air-compressor, by which the air is withdrawn or exhausted, and thus the cold or frozen air is kept in constant circulation through the cooling or freezing chamber or room.

I prefer to use the cold air over and over again in this way, as the air will by this method soon become perfectly dry, but I reserve to myself the right to use fresh atmospheric air when found desirable.

In order to prevent the obstruction of the refrigerating apparatus by the accumulation of ice in or upon the pipes of the refrigerator by the congelation of the moisture contained in the air, I propose to have two or more refrigerators in conjunction, arranging and providing them with passages and slides in such a manner that the direction of the current of air which is to be cooled may be reversed at will, and so that the said current may be diverted from either one or more of the series without interrupting the flow of the said air through the other vessels of the same series.

My invention is illustrated by the various figures on the sheet of drawings annexed hereto, and forming part of this specification, figure 1 being a longitudinal view (partly in elevation and partly in section) of a series of four refrigerating vessels constructed and arranged according to my invention; figure 2 is a transverse vertical section of one of the refrigerating vessels; figure 3 is a horizontal section on the line A B in figure 1; and figure 4 is a plan view taken at the line C D in the same figure.

*aa* is the rectangular base subdivided into compartments or depositing chambers *bb* by partitions; *cc*, *dd* are casings or cylinders with domed tops, and containing groups of bent pipes or tubes *ee*, the lower ends of which are fitted into holes in tube plates *ff*; *gg* is a midfeather or partition between the legs of the pipes *ee*, and *hh* is a continuation of the same below the tube plates *ff*, and resting on partitions *cc* in the base; *ii* is a drain-pipe underlying the base *aa*, and provided with semi-partitions *kk*, which are a further continuation of the partitions *cc* beneath the base; *ll* are inlet-pipes for the air to be cooled, and *mm* are outlet pipes for the cooled or frozen air, which are in communication with the perforated trunks at or near the bottom of the cooling or freezing chamber or room.

The air inlet pipe *ll* is connected with the blower or air-compressor; *nn* are openings from the air passages into the depositing chambers or compartments *bb*; *oo* are inlet and outlet pipes for the cold brine or other cooling or freezing medium, which pipes are provided with three way-cocks; *pp* *qq* are slides or valves in the brine pipes, and *rr* are slides or valves in the air passages.

The action of the apparatus is as follows:—The brine pipes *oo* are put in connection with a cold producing arrangement, such as an ordinary sulphurous-oxide or ammonia freezing or cooling machine for example, and the cylinders *dd* are filled above the tube plates *ff* with the said brine or non-congealable liquid, which is kept in constant circulation through the said cylinders *dd*, and through the refrigerator of the said cold-producing machine or arrangement, whilst at the same time the air to be cooled or frozen circulates through the interior of the bent pipes *ee*. When it is desired that the air shall be cooled down below the freezing point, the admission of brine to the first refrigerator is regulated so that the air becomes cooled down in the first refrigerating vessel nearly, but not quite, to the freezing point, whereby the greater part of the moisture contained in such air is condensed and falls down into the depositing chamber *bb* at the bottom of the vessel, in the form of water, whence it passes off through holes at the lowest point into the drain pipe *ii* provided for that purpose, and from which it can be withdrawn by suitable drain cocks or traps.

The air being thus deprived of the greater part of its moisture (say about nine-tenths), and being hence almost dry, passes on through the other refrigerating vessels, where it is cooled down to the required degree, and nearly all the remaining moisture frozen out of it, and deposited in the pipes or tubes of the refrigerator before being conveyed through the perforated wooden tubes or trunks, or otherwise, into the cooling or freezing chamber or room.

This method of cooling the air down nearly, but not quite, to the freezing point, so as to condense and extract the greater part of the moisture in the form of water before freezing the remainder, forms one of the principal features of my invention, and enables me to overcome the difficulty heretofore found in apparatus of this description, namely, the rapid choking-up of the pipes or tubes with snow or ice formed from the moisture deposited on the sides thereof.

Should the very small amount of moisture still remaining in the air, in course of time freeze in the interior of the pipes *ee* of the refrigerating vessels, so as to partially choke up such pipes, the fact will be indicated either by an increase of temperature of the air between the blower and the refrigerator, or by an increase of pressure in the pipe leading from the fan, and when this occurs I reverse the direction of the

*Improvements in Refrigerating and Freezing, &c.*

the current of air through the refrigerating vessels by altering the position of the slides or valves *rr*, and admit external air to the fan or blower for a few minutes, which air, passing in the reverse direction, and being at an increased temperature, will at once clear the ice or frost from the pipes.

In case this method should at any time prove insufficient to prevent the freezing up of any of the pipes, or to remove the snow or ice therefrom, I provide means for withdrawing the cold brine or other cooling or freezing medium from the space round the bent pipes *ee* in the refrigerating vessel, and for introducing steam, warm water, or warm air into the pipes; but this would only be required when the apparatus has been worked too long with the air travelling in one direction, or when the air, charged with moisture, has been cooled too quickly. I may here remark that in cases where the air is required to be cooled to a temperature not below freezing point, a single apparatus of this construction may be conveniently applied, and that by a slight modification the apparatus may be so arranged that the brine or cooling medium shall circulate through the pipes whilst the air to be cooled is passed through the space around them, but I prefer the plan above described.

I would also observe that, although my improved apparatus is shown and described above as a secondary apparatus for conveying or imparting to the air the cold from brine or other medium previously cooled nearly to freezing point by a primary cold producing machine or arrangement, the same apparatus may also be employed as a primary cold producing arrangement itself, by filling the space round the pipes *ee* more or less with a highly volatile liquid such as sulphurous-oxide or liquid ammonia, and vaporizing the same by exhaustion through a pipe or pipes opening into the upper part of the cylinder *d*, the air passing through the pipes or tubes *e* as before; or in some cases the volatile liquid may be placed inside the pipes or tubes, and the air circulate outside the same. Instead of causing the brine or other cooling medium to pass over the partitions *g* in the cylinders *d*, these partitions may be dispensed with, and the brine or other medium simply allowed to enter the cylinders *d* at the bottom, and to issue therefrom at or near the top, or *vice versa*, but I prefer to employ the partitions *g*.

The pipes or tubes *e* may be arranged in other ways; for example, instead of being of U shape, with both branches of the U fixed in the same tube-plate, they may be straight, and secured at both ends in separate tube-plates, but I prefer the arrangement shown, as by that means the inconvenience of unequal expansion of the pipes or tubes, and their casing, is avoided, as is well understood.

Instead of the air being forced through the refrigerating apparatus by a blowing fan or other air forcing or compressing apparatus, it may be drawn through by an exhaust fan or other suitable exhausting apparatus.

The brine or other cooling medium should be made to pass through the cylinders *d* in a direction opposite to that of the air through the pipes or tubes *e*.

In some cases it will be found preferable to make the vessels *d* of an oblong or other form, instead of cylindrical, especially where space is an object, as on board ship for instance.

In conclusion, I desire it to be understood that I do not claim generally cooling air by causing it to pass in contact with surfaces cooled by a refrigerating medium, as I am aware that such process has been tried in various ways before; nor do I claim any particular means or method of introducing the air to or withdrawing it from the cooling or freezing chamber or room, as that may be effected by means other than the trunks hereinbefore referred to; nor do I wish to limit myself to the precise details herein described and illustrated by the drawings, as they may be modified to suit various circumstances without departing from the nature of my invention, but what I do claim as my invention is:—

Firstly—The novel system or method of removing from the air the moisture contained therein, by first cooling the air down to a temperature more or less above the freezing point of water, so as to condense and extract the greater part of the said moisture from the air in the form of water, and afterwards, when required, further reducing the temperature of the said air below the freezing point, and effecting the deposit of the remaining comparatively small quantity of moisture in the form of snow or ice in the refrigerating apparatus, substantially as hereinbefore described.

Secondly—In the construction of air refrigerating and freezing apparatus, the combination of a group or groups of refrigerating pipes or tubes, with depositing chambers for the reception of the moisture condensed in or on such pipes or tubes, such depositing chambers being adapted with slides, valves, or their equivalents, whereby the current of air may be directed through one or more of the groups of refrigerating pipes or tubes, and in either direction at pleasure, substantially as hereinbefore described and illustrated in the drawings hereto annexed.

Thirdly—The employment in air-refrigerating apparatuses, of one or more groups of U-shaped refrigerating pipes or tubes, enclosed in suitable casings, the two ends of each of the said pipes or tubes forming one group being secured in one tube-plate, in such manner as to open into the moisture-depositing chamber at opposite sides of the division-plate in such chamber, substantially as hereinbefore described, and illustrated in the drawings hereto annexed.

Fourthly—The combination with air-refrigerating and freezing apparatus, of the kind hereinbefore described and illustrated in the drawings, of a blowing or exhausting fan, or other air-compressing or exhausting apparatus, as hereinbefore described, and for the purposes specified.

In witness whereof, I, the said John Chambers, have hereto set my hand and seal, this third day of November, in the year of our Lord one thousand eight hundred and eighty-two.

Witnesses—

JOHN HOLDSWORTH,  
Barclay House, Eccles, Manchester.  
STEPHEN EDWARD GUNRON,  
139, Cannon-street, London.

JOHN CHAMBERS.

This is the specification referred to in the annexed Letters of Registration granted to John Chambers, this 23rd day of February, A.D. 1883.

AUGUSTUS LOFTUS.

REPORT.



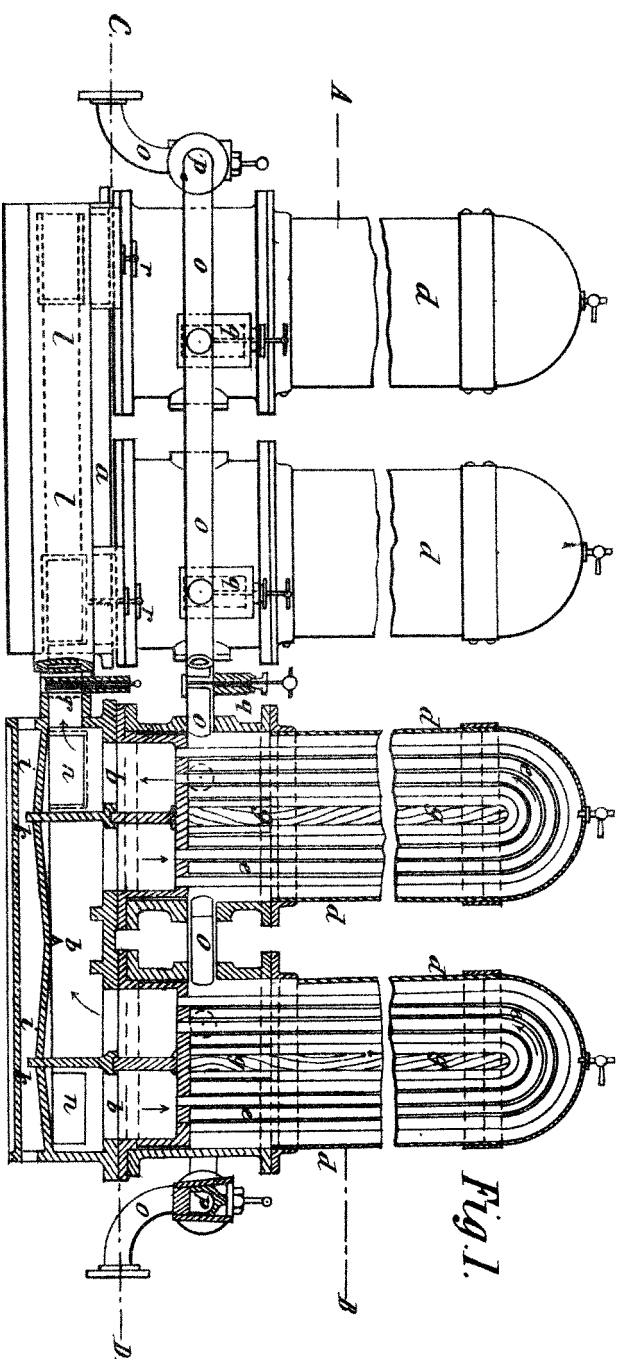


Fig. 1.

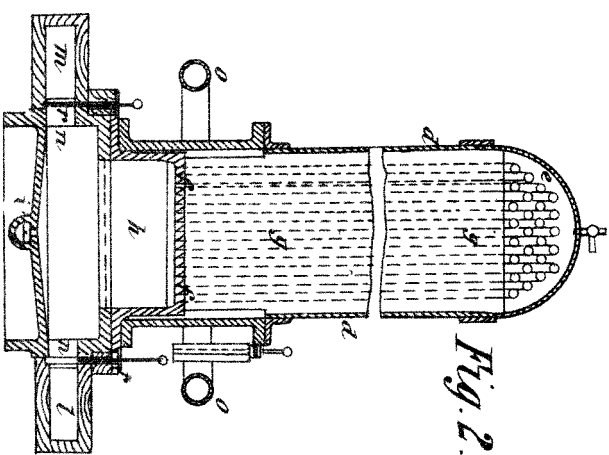


Fig. 2.

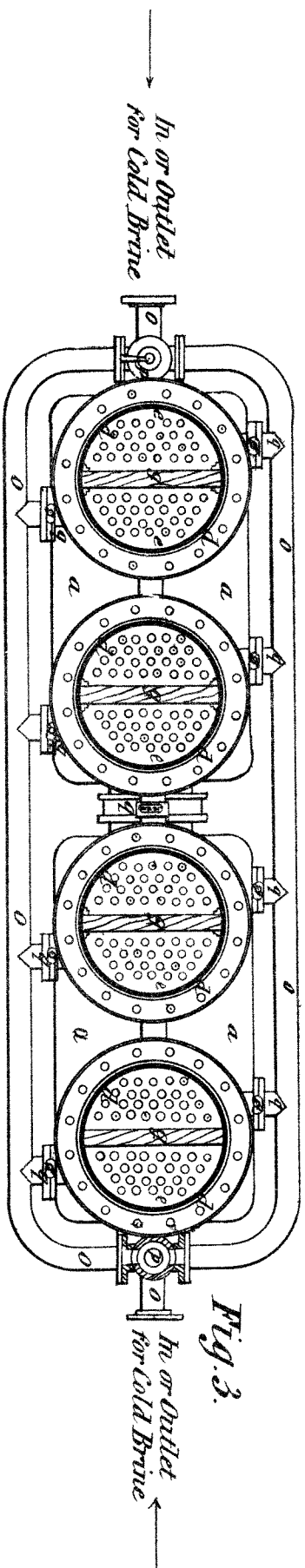


Fig. 3.

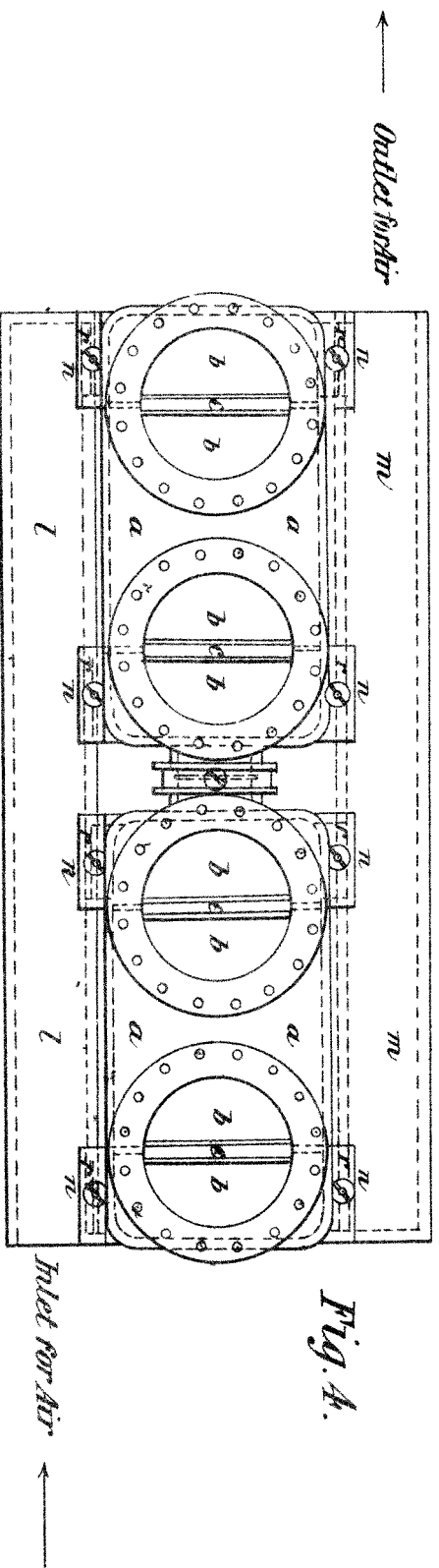


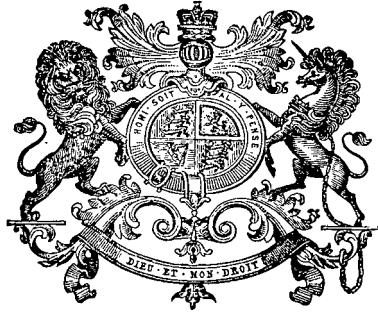
Fig. 4.

*This is the Sheet of Drawings referred to in the annexed  
 Letters of Registration granted to John Chambers, this 23<sup>rd</sup>  
 day of February A.D. 1883.*

*Augustus Loftus.*

(Sig 35-)

PHOTO-LITHOGRAPHED AT THE GOVT. PRINTING OFFICE,  
 SPINNEY NEW SOUTH WALES



A.D. 1883, 23rd February. No. 1201.

A MACHINE FOR MINING TUNNELS, &c.

LETTERS OF REGISTRATION to Edward Pritchard, for an invention entitled  
 "A Machine for Mining Tunnels, by cutting grooves round the sides of  
 Tunnels, Drives, Sewers, or Drains, in rock or other material."

[Registered on the 24th day of February, 1883, in pursuance of the Act 16 Vic. No. 24.]

BY HIS EXCELLENCY THE RIGHT HONORABLE SIR AUGUSTUS WILLIAM FREDERICK SPENCER LOFTUS  
 (commonly called LORD AUGUSTUS LOFTUS), Knight Grand Cross of the Most Honorable Order of  
 the Bath, a Member of Her Majesty's Most Honorable Privy Council, Governor and Commander-in-  
 Chief of the Colony of New South Wales and its Dependencies.

TO ALL TO WHOM THESE PRESENTS SHALL COME, greeting:

WHEREAS EDWARD PRITCHARD, of Sydney, in the Colony of New South Wales, hath by his  
 Petition humbly represented to me that he is the author or designer of a certain invention or improvement  
 in manufactures, that is to say, of an invention entitled "A Machine for Mining Tunnels, by cutting  
 grooves round the sides of Tunnels, Drives, Sewers, or Drains, in rock or other material," which is more  
 particularly described in the specification and the sheet of drawings which are hereunto annexed; and  
 that he, the said Petitioner, hath deposited with the Honorable the Treasurer of the said Colony of New  
 South Wales the sum of Twenty Pounds sterling, for defraying the expense of granting these Letters of  
 Registration as required by the Act of Council, sixteenth Victoria, number twenty-four; and hath humbly  
 prayed that I would be pleased to grant Letters of Registration, whereby the exclusive enjoyment and  
 advantage of the said invention or improvement might be secured to him for a period of fourteen years:  
 And I, being willing to give encouragement to all inventions and improvements in the arts or manufactures  
 which may be for the public good, and having received a report favourable to the prayer of the said  
 Petition, from competent persons appointed by me to examine and consider the matters stated therein  
 and to report thereon for my information, am pleased, with the advice of the Executive Council, and in  
 exercise of the power and authority given to me by the said Act of Council to grant, and do by these  
 Letters of Registration grant unto the said Edward Pritchard, his executors, administrators, and assigns,  
 the exclusive enjoyment and advantage of the said invention or improvement, for and during the term of  
 fourteen years from the date hereof; to have, hold, and exercise unto the said Edward Pritchard, his  
 executors, administrators, and assigns, the exclusive enjoyment and advantage thereof, for and during and  
 unto the full end and term of fourteen years from the date of these presents next and immediately ensuing,  
 and fully to be complete and ended: Provided always, that if the said Edward Pritchard shall not, within  
 three days after the granting of these Letters of Registration, register the same in the proper office in the  
 Supreme Court, at Sydney, in the said Colony of New South Wales, then these Letters of Registration,  
 and all advantages whatsoever hereby granted, shall cease and become void.

In witness whereof, I have hereunto set my sign manual, and have caused the present Letters of  
 Registration to be sealed with the seal of the said Colony of New South Wales, at Govern-  
 ment House, Sydney, in New South Wales, this twenty-third day of February, in the year  
 of our Lord one thousand eight hundred and eighty-three.

[L.S.]

AUGUSTUS LOFTUS.

*A Machine for Mining Tunnels, &c.*

SPECIFICATION of EDWARD PRITCHARD, of Sydney, in the Colony of New South Wales, contractor, for an invention of a "Rock-cutting Machine."

My invention relates more particularly to a "Machine for cutting a slot or groove, wholly or in part, round the sides of shafts, tunnels, or other places, in rock or other materials."

This invention consists of a travelling tool, worked on a frame, marked A on the plan, and capable of being traversed round such frame by ratchets and pinions, or other mechanical contrivances, as shown, marked G and H. Such tool is worked by air, steam, or other vapour, through valve L, causing such tool to have a reciprocating motion, and being guided by the angle-iron frame, A, cuts a slot or groove to the dimensions regulated by the guide-frame, and to the depth as allowed for on the traverse screw, K.

The cylinder, C, and valve-gear, L, is capable of being moved in slots in the saddle, and being moved horizontally by the screw, K, round the guide-frame, or by the ratchet, G, and air, steam, or other vapour being admitted through the valve, L, to the piston, D, causing such piston carrying the cutting tool to have a reciprocating motion; and such tool or cutting edge being brought in contact with rock or other material, cuts a slot or groove, as regulated by guide, to the exact dimensions of frame A.

Counterbalance weights, X, as shown on general plan No. 1, are used to counteract the downward tendency of the travelling gear. N are adjustment screws.

Figure 1 is a general plan of the machine, as adapted for cutting sewers or drains.

Figure 2 is a detail of the angle-iron framing.

Figure 3 is a section through the power cylinder, and shows the general arrangement of the traverse screw.

Figure 4 is a plan of machine, showing racks and pinions for side traverse. AA is the angle-iron frames; P is the traverse nut; C is the cylinder; D is the piston; EE are the pressure rollers; FF the screws for keeping the pressure rollers, EE, up to the angle iron frame, A; GG is a rack of the shape as required to be cut; HH are the pinions that work into such racks and give the form and dimensions of such cut; J is the cutting tool; K is the traverse screw, which can be long or short, in accordance with the depth desired to be cut; L is the valve for admitting air, steam, or other vapour.

Having now described the nature of my invention, and the manner in which the same is to be performed, I wish it to be understood, that I do not limit myself to the precise details herein described and illustrated, as the same may be varied without departing from the nature of my invention; but I claim for my invention—

First—The general arrangement of the several parts, and the capability of working such machine round a frame, and so cutting a slot or groove the exact size of the tunnel or sewer required.

Second—I claim the novelty of cutting such groove round a tunnel or sewer, so as to relieve the centre portion, and enable such portion to be more easily removed.

EDWARD PRITCHARD.

Dated at Sydney this nineteenth day of December, 1882.

This is the specification referred to in the annexed Letters of Registration granted to Edward Pritchard, this twenty-third day of February, A.D. 1883.

AUGUSTUS LOFTUS.

---

REPORT.

Sir,

Having examined the plan and specification accompanying the Petition, we have the honor to recommend that Letters of Registration should be issued to Mr. Edward Pritchard, for an invention entitled "A Machine for Mining Tunnels, &c.," as shown in the drawing and described in the specification attached to the Petition.

The Under Secretary of Justice.

Sydney, 3 January, 1883.

We have, &c.,

E. O. MORIARTY.  
JAMES BARNET.



DRAWING N<sup>o</sup> 1

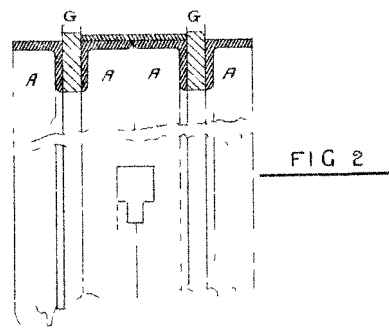


FIG 2

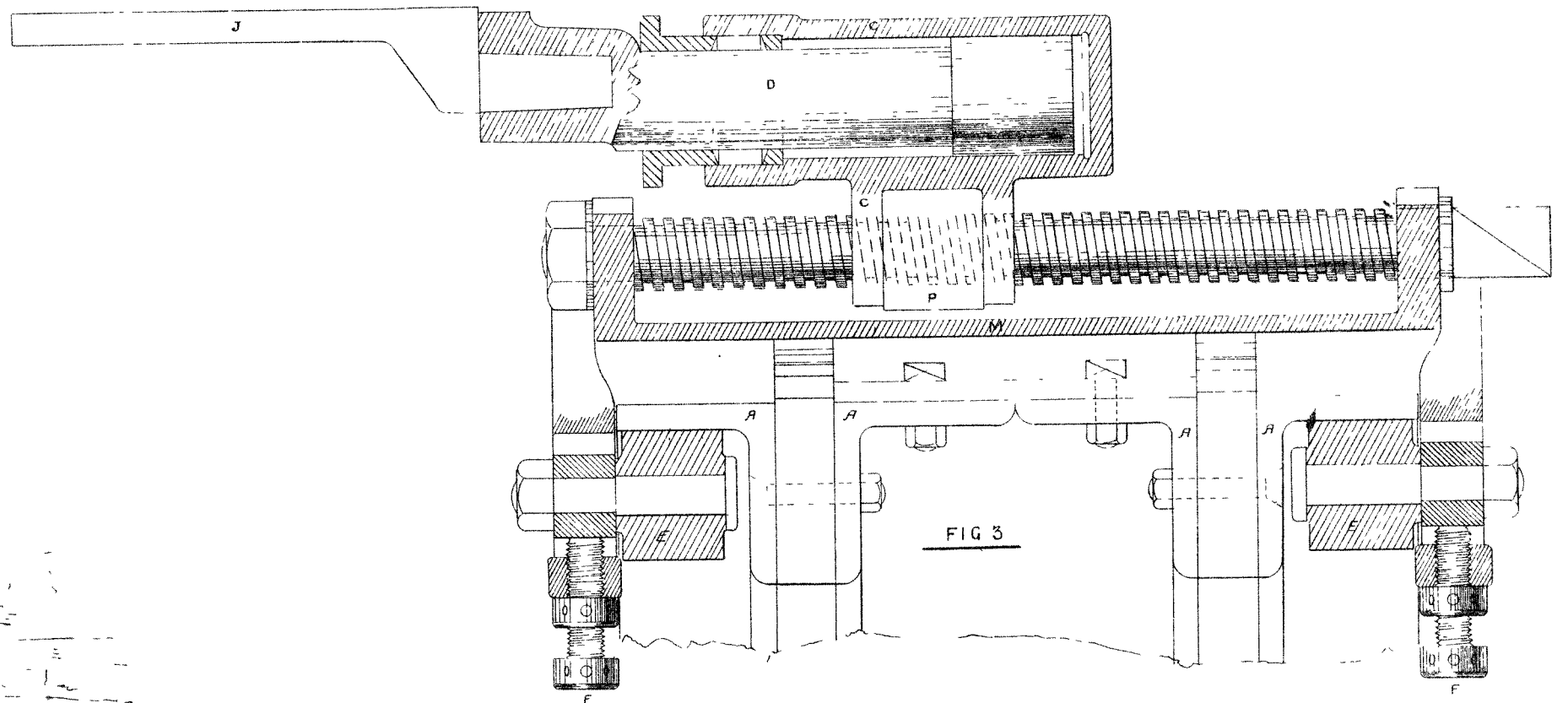


FIG 3

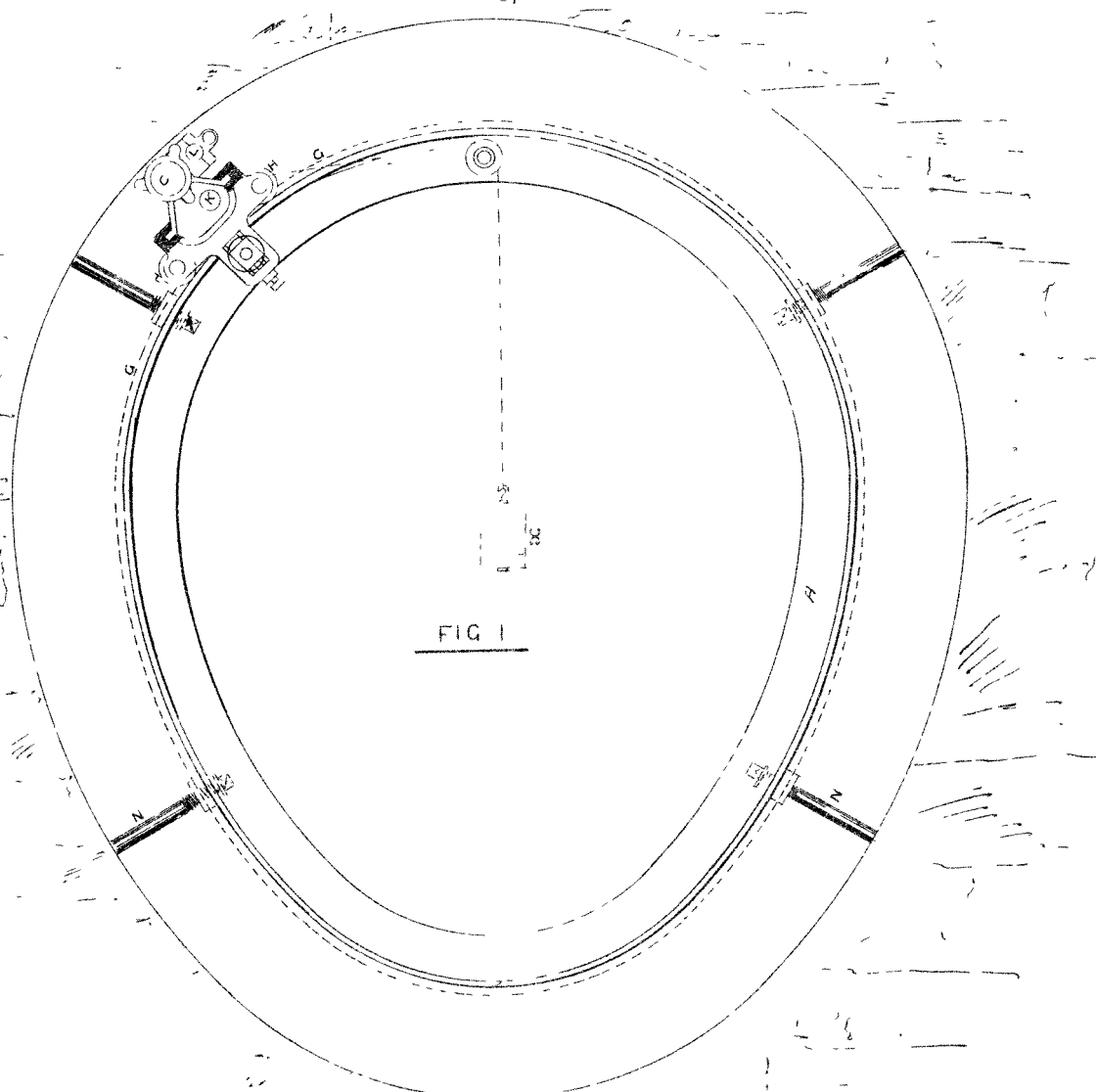


FIG 1

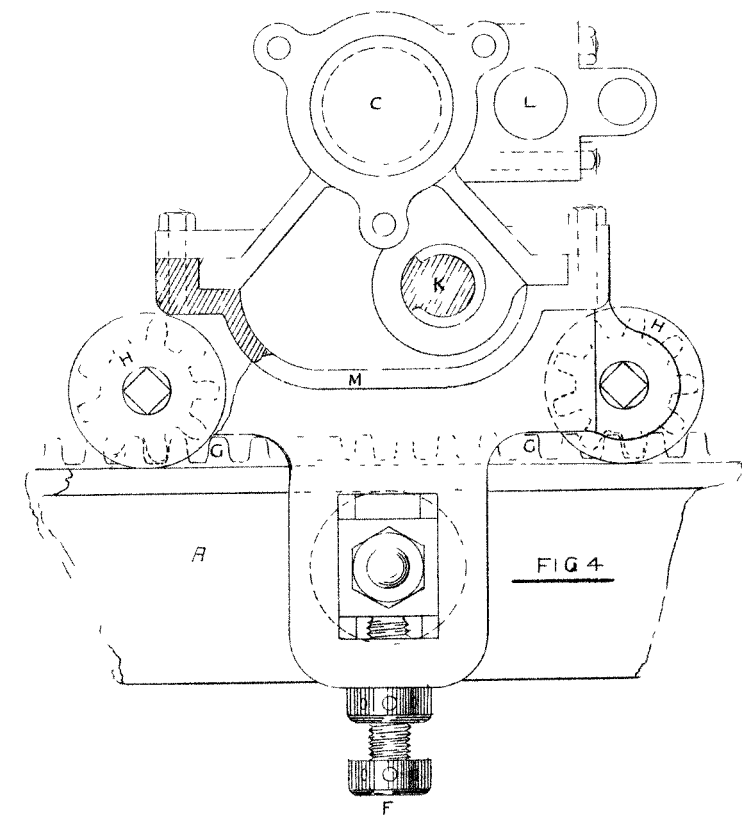


FIG 4

*This is the Sheet of Drawings referred to in the annexed  
 Letters of Registration granted to Edward Pritchard,  
 this twenty third day of February, A.D. 1883.  
 Augustus Loftus.*



A.D. 1883, 1st *March*. No. 1202.

A MACHINE FOR MANUFACTURING BURNING GAS.

LETTERS OF REGISTRATION to Henry Caspers, for an invention entitled,  
 "A Machine for Manufacturing Burning Gas."

[Registered on the 1st day of March, 1883, in pursuance of the Act 16 Vic. No. 24.]

BY HIS EXCELLENCY THE RIGHT HONORABLE SIR AUGUSTUS WILLIAM FREDERICK SPENCER LOFTUS (commonly called LORD AUGUSTUS LOFTUS), Knight Grand Cross of the Most Honorable Order of the Bath, a Member of Her Majesty's Most Honorable Privy Council, Governor and Commander-in-Chief of the Colony of New South Wales and its Dependencies.

TO ALL TO WHOM THESE PRESENTS SHALL COME, greeting :

WHEREAS HENRY CASPERS, of Goulburn, in the Colony of New South Wales, professor of music, hath by his Petition humbly represented to me that he is the author or designer of a certain invention or improvement in manufactures, that is to say, of an invention of "A Machine for Manufacturing Burning Gas," which is more particularly described in the amended specification and the sheet of drawings which are hereunto annexed; and that he, the said Petitioner, hath deposited with the Honorable the Treasurer of the said Colony of New South Wales the sum of Twenty Pounds sterling, for defraying the expense of granting these Letters of Registration, as required by the Act of Council, sixteenth Victoria, number twenty-four, and hath humbly prayed that I would be pleased to grant Letters of Registration, whereby the exclusive enjoyment and advantage of the said invention or improvement might be secured to him for a period of fourteen years: And I, being willing to give encouragement to all inventions and improvements in the arts or manufactures which may be for the public good, and having received a report favourable to the prayer of the said Petition, from competent persons appointed by me to examine and consider the matters stated therein and to report thereon for my information, am pleased, with the advice of the Executive Council, and in exercise of the power and authority given to me by the said Act of Council, to grant, and do by these Letters of Registration grant unto the said Henry Caspers, his executors, administrators, and assigns, the exclusive enjoyment and advantage of the said invention or improvement, for and during the term of fourteen years from the date hereof; to have, hold, and exercise unto the said Henry Caspers, his executors, administrators, and assigns, the exclusive enjoyment and advantage thereof, for and during and unto the full end and term of fourteen years from the date of these presents next and immediately ensuing, and fully to be complete and ended: Provided always, that if the said Henry Caspers shall not, within three days after the granting of these Letters of Registration, register the same in the proper office in the Supreme Court, at Sydney, in the said Colony of New South Wales, then these Letters of Registration, and all advantages whatsoever hereby granted, shall cease and become void.

In witness whereof, I have hereunto set my sign manual, and have caused the present Letters of Registration to be sealed with the seal of the said Colony of New South Wales, at Government House, Sydney, in New South Wales, this first day of March, in the year of our Lord one thousand eight hundred and eighty-three.

[L.S.]

AUGUSTUS LOFTUS.

*A Machine for Manufacturing Burning Gas.*

## SPECIFICATION.

THE gas machine, which has been invented by HENRY CASPERS, is called "the Success." The oil used to make the gas is made of shale at the Kerosene Works.

The oil is brought in connection with a pipe through which air passes, this air is brought into contact with the oil, thus producing a brilliant light.

What I claim as my patent is the simple way how the air is brought in connection with the oil. I do not claim the apparatus E, which represents a wet meter for coal gas; this apparatus E brings the air in the gas machine.

No. 1 is the oil plug, for pouring in the oil, the oil drops on a board 2, this board breaks the fall of the oil. Enough oil is poured in a vessel A, until it reaches guage tap 20, vessel A has an iron bottom 19. Near this bottom of vessel A, is a small tube 4, with an oil tap 5, to let out sufficient oil to supply a certain number of lights. Under pipe 4 is another pipe 25, for bringing air from apparatus E, in connection with the oil. The oil pipe 4, and air pipe 25, go in a small compartment 6, which compartment is filled with shavings and sponges. The oil and air are allowed to mix in this compartment, from here the oil and air now passes through a coil of piping 7, this piping is fixed in the middle part of compartment 6. The oil and air now having gone through different rounds, goes now into compartment 11; this compartment is filled with shavings and sponges; I use shavings and sponges because it adds a great deal towards getting a steady light, also it improves the gas. The mixture of oil and air which through this simple process has now become gas, forces its way through a wooden partition 12, which is full of holes; the gas having arrived in vessel C now goes through a wooden bottom 18 with holes in centre part, the gas having arrived in compartment B, which is filled with shavings (besides coil of piping), the gas passes through pipe 23 into governor D; I either use one or two governors according to number of lights required, for a small machine of 12 lights I use only one governor, but for more lights I use two governors D. The governor is used to produce a steady light; I do not claim the governor D as my invention; when sufficient gas is in governor D it will force its way back through a wooden partition 24 which is full of holes; from here the gas goes into the main outlet 26 in about a week or fortnight's time, when all the oil has emptied itself out of vessel A into vessel C, the oil makes its way through the holes in wooden partition 12 into small compartment 16. The oil from here is then pumped back again into vessel A; I do not claim the pump F nor do I claim apparatus E, which brings the air into gas machine.

The apparatus E which represents a wet meter for coal gas, can be worked either by weight or spring power; No. 27 is the air pipe, which leads into a small compartment 28, this compartment receives the evaporated water from wet meter; No. 29 is the tap to let off the water, so that it does not come into vessel A; from compartment 28 the air then goes through pipe 30 into gas machine.

Should the oil become very poor, the oil is warmed slightly by a small gas burner 22; by means of this the oil gets strong again and makes good gas.

Sydney, 2nd January, 1883.

H. CASPERS.

This is the amended specification referred to in the annexed Letters of Registration granted to Henry Caspers, the first day of March, A.D. 1883.

AUGUSTUS LOFTUS.

## REPORTS.

Sir,

Sydney, 18th December, 1882.

In accordance with your letter of the 11th November, we have examined the specification and plan attached to the application of Henry Caspers, for protection for an invention for the manufacture of gas from oil, and have to report that the plan is so crude, the specification so indefinite, and description so imperfect that we are unable to advise that the protection applied for be granted.

We have, &c.,

JAMES BARNET.  
WILLIAM C. BENNETT.

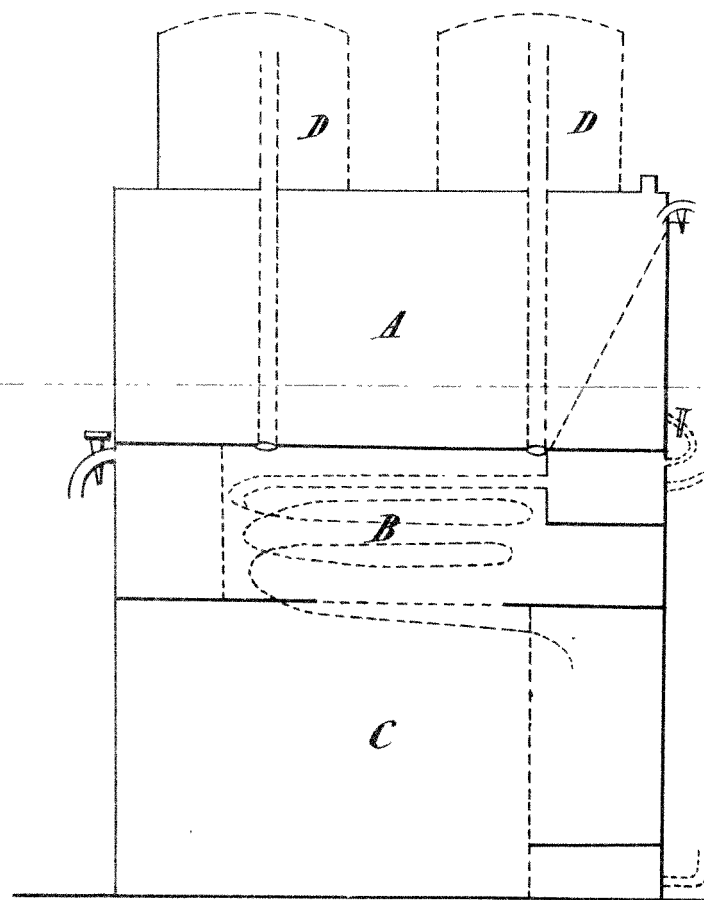
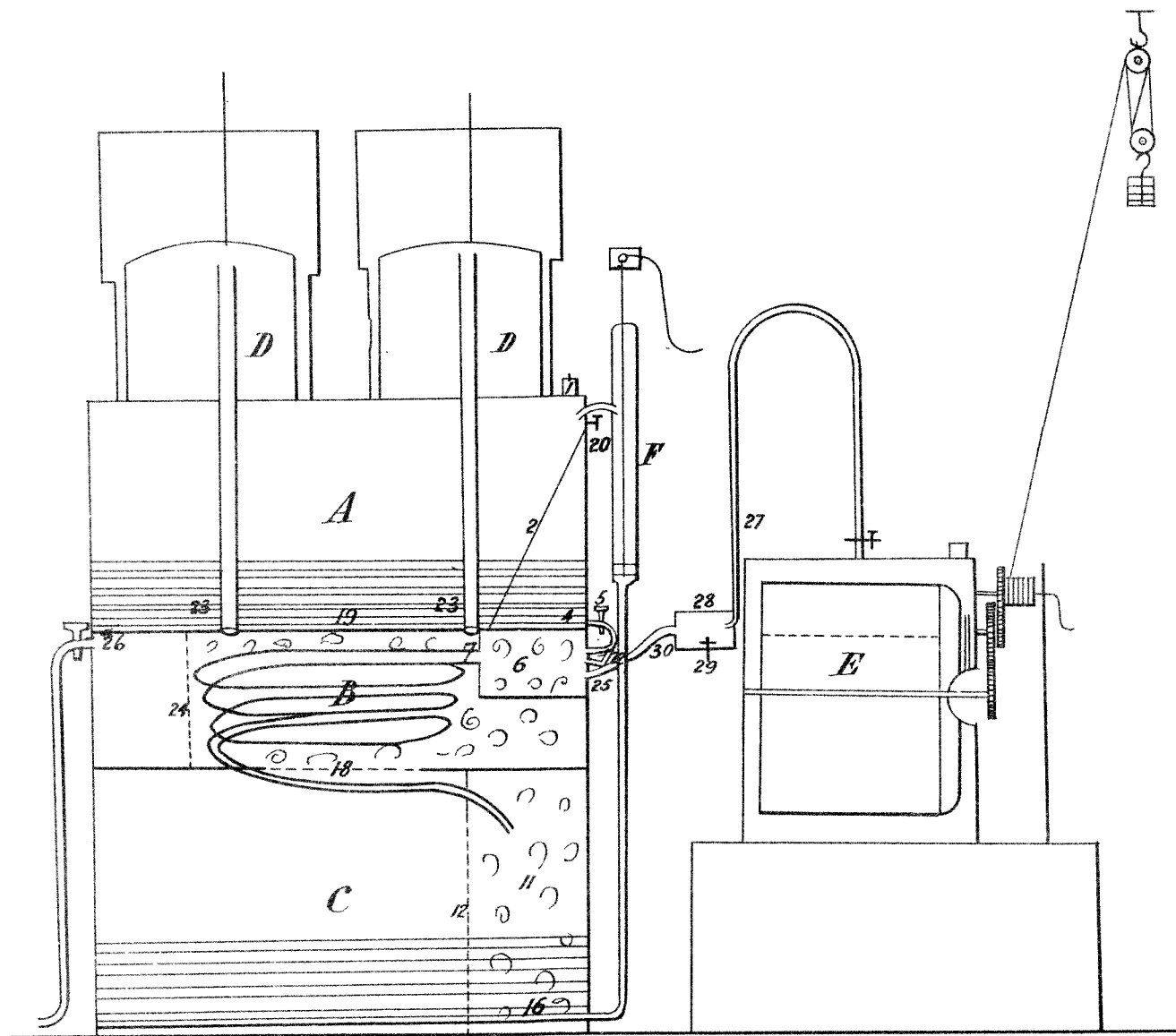
The Under Secretary of Justice.

9th January, 1883.

Mr. Caspers having produced model and amended specification, the protection might now be granted.

JAMES BARNET.  
WILLIAM C. BENNETT.

The Under Secretary of Justice.



# Gas Machine

Sydney January 2<sup>nd</sup> 1883.

H. Caspers.

*This is the Sheet of Drawings referred to in the annexed Letters of Registration granted to Henry Caspers this first day of March A.D. 1883.*

*Augustus Loftus.*



A.D. 1883, 5th March. No. 1203.

IMPROVEMENTS IN TRAMWAY LOCOMOTIVES.

LETTERS OF REGISTRATION to William Wilkinson, for Improvements in Tramway Locomotives.

[Registered on the 6th day of March, 1883, in pursuance of the Act 16 Vic. No. 24.]

BY HIS EXCELLENCY THE RIGHT HONORABLE SIR AUGUSTUS WILLIAM FREDERICK SPENCER LOFTUS (commonly called LORD AUGUSTUS LOFTUS), Knight Grand Cross of the Most Honorable Order of the Bath, a Member of Her Majesty's Most Honorable Privy Council, Governor and Commander-in-Chief of the Colony of New South Wales and its Dependencies.

TO ALL TO WHOM THESE PRESENTS SHALL COME, greeting :

WHEREAS WILLIAM WILKINSON, of Wigan, in the county of Lancashire, England, engineer, hath by his Petition humbly represented to me that he is the author or designer of a certain invention or improvement in manufactures, that is to say, of an invention entitled "Improvements in Tramway Locomotives," which is more particularly described in the specification and the sheet of drawings which are hereunto annexed ; and that he, the said Petitioner, hath deposited with the Honorable the Treasurer of the said Colony of New South Wales the sum of Twenty Pounds sterling, for defraying the expense of granting these Letters of Registration, as required by the Act of Council, sixteenth Victoria, number twenty-four ; and hath humbly prayed that I would be pleased to grant Letters of Registration, whereby the exclusive enjoyment and advantage of the said invention or improvement might be secured to him for a period of fourteen years : And I, being willing to give encouragement to all inventions and improvements in the arts or manufactures which may be for the public good, and having received a report favourable to the prayer of the said Petition from competent persons appointed by me to examine and consider the matters stated therein and to report thereon for my information, am pleased, with the advice of the Executive Council, and in exercise of the power and authority given to me by the said Act of Council, to grant, and do by these Letters of Registration grant unto the said William Wilkinson, his executors, administrators, and assigns, the exclusive enjoyment and advantage of the said invention or improvement, for and during the term of fourteen years from the date hereof ; to have, hold, and exercise unto the said William Wilkinson, his executors, administrators, and assigns, the exclusive enjoyment and advantage thereof, for and during and unto the full end and term of fourteen years from the date of these presents next and immediately ensuing, and fully to be complete and ended : Provided always, that if the said William Wilkinson shall not, within three days after the granting of these Letters of Registration, register the same in the proper office in the Supreme Court, at Sydney, in the said Colony of New South Wales, then these Letters of Registration, and all advantages whatsoever hereby granted, shall cease and become void.

In witness whereof, I have hereunto set my sign manual, and have caused the present Letters of Registration to be sealed with the seal of the said Colony of New South Wales, at Government House, Sydney, in New South Wales, this fifth day of March, in the year of our Lord one thousand eight hundred and eighty-three.

[L.S.]

AUGUSTUS LOFTUS.

*Improvements in Tramway Locomotives.*

SPECIFICATION of WILLIAM WILKINSON, of Wigan, in the county of Lancashire, England, engineer, for an invention entitled "Improvements in Tramway Locomotives."

THE general object of my invention is to effect a combination of mechanical contrivances in a tramway locomotive, whereby the steam motor shall be rendered less an object of terror to timid persons and animals in the streets of cities.

This invention consists in certain novel combinations of parts which have been united with other parts in a tramway locomotive to accomplish the aforesaid object, and in certain novel features of some of the parts of the said tramway locomotive, as hereinafter described and claimed.

In the drawings which accompany this specification figure 1 is a side elevation of my improved tramway locomotive, figure 2 is a sectional elevation of the same, and figure 3 is another side elevation thereof.

In order to render the locomotive small and compact, an upright or vertical boiler, fitted with what are known as "Field's patent tubes," has been adopted as the basis of this locomotive, the same being mounted on suitable framing, with track-wheels and other accessories, which do not require particular mention.

Two inverted direct-acting cylinders A drive two cranks B at right angles one to the other. The crank-shaft is rigidly attached to the framing of the engine, and is fitted with a gun-metal, wrought-iron, or steel spur-wheel C, gearing with a second spur-wheel D, keyed on the driving axle S, on which are keyed the driving wheels to run on the tram-rails. These wheels may be coupled to the trailing or leading wheels, or to both, if required. By this method of connection of engines to driving wheels I obviate "galloping," or a jumping action of the locomotive on the road, that would take place if the engine were connected with the driving wheel axle directly.

Two jackets E, made from wrought or cast iron, or other suitable material, are fixed one on each side of the boiler F, and closely attached thereto, so as to be heated to the same temperature as the boiler. The steam from the cylinder A is exhausted into these jackets, and there heated, any water that may have passed over with the said exhaust steam being thereby intercepted and partially evaporated. From these jackets are led two pipes G, passing into and down the inside of the uptake or chimney of the furnace into a vessel H made from cast-iron, or any suitable material, suspended inside the furnace at any convenient distance below the foot of the uptake, and acting as a distributor of the heated gases among the tubes. From this vessel an enlarged pipe I is led vertically any convenient distance up the uptake, directing the waste steam up the chimney in a dry and super-heated state, invisible to the eye, while it increases the draught of the furnace in the usual manner.

The before-mentioned vessel H into which the waste or exhaust steam is finally led, being exposed to the greatest heat of the furnace J, effectually super-heats and dries the steam, so that no water can be emitted from the funnel, and owing to the steam being expanded in two separate vessels after leaving the cylinders of the engine, the pressure is thereby so much reduced as to decrease to a minimum the noise of the exhaust steam when reaching the air.

The safety-valves T are enclosed in a box from which two pipes are led, one into each of the jackets E, in order to reduce to a minimum the noise resulting from blowing off steam from over-pressure.

The waste-pipes from the cylinders are also led into the jackets E, thereby preventing any noise of escape when the engine is starting on a journey with the cylinder-cocks open for the discharge of water from the cylinders.

All water led into or produced by condensation within the before-mentioned side-jackets is led therefrom by a pipe or pipes into a steam and water-tight tank, which may be carried on any convenient part of the locomotive, and which can be emptied at will.

To control and equalize the speed of the locomotive a governor is employed, preferably of the class known as "Allen's paddle governor," to reverse the valve gear and apply the brakes when a given speed is attained. This is effected by means of an eccentric cam K, with a lever motion, which opens a valve against the boiler pressure, thereby allowing the water or steam to pass through a pipe U to the under side of one or more pistons or hydraulic rams N, in direct communication with the reversing shaft L and brake-shaft M, reversing the engine and applying the brakes at one and the same time and automatically. In the under side of the hydraulic or steam cylinders before-mentioned, containing the pistons or rams N, it is proposed to fix taps or cocks and pipes, which can be used for regulating the outflow of the steam or water after reversing the engine.

The connection between each ram or piston N and the reversing shaft L is made by means of a slotted link O of such kind that the engine can be reversed in the usual manner by hand, without moving the said ram or piston; but the said pistons cannot be moved without reversing the engine. The same kind of slotted connection is introduced between said pistons N and the brake-shaft M, to provide for applying the brakes by hand or foot, in the usual manner.

In the ordinary field-boiler the portion of the uptake or chimney which passes through the steam space above the water-line inside the boiler is liable to have scale and hard mud formed upon it by reason of the scum floating on the surface of the water becoming baked and attached thereto, and this at times dropping off, and choking or fouling the circulating tubes, interferes with the effectual circulation of the water, thereby causing the tubes to burn out. To obviate this a disc Q of iron, copper, or other suitable material, is fitted on the uptake P inside the boiler, so as to catch and intercept any scale that may be formed, and prevent it falling into the tubes.

The chimney or uptake passing through the steam space, as aforesaid, is subject to a very high temperature, and invariably wastes away very much more rapidly at this point than at any other portion of the boiler. This part is protected then by fitting a wrought-iron or other suitable casing R inside the uptake, where the same passes through and above the water-line of the boiler. An annular space is left inside the casing, which may be packed with fire-clay or other non-conducting and fire-resisting material, or the space may, if desired, be left vacant.

What

*Improvements in Tramway Locomotives.*

What I claim as novel, and desire to protect by Letters Patent, is—

1. The combination in a tramway locomotive of chambers or jackets attached to the boiler pipes, conducting escape steam thereto, and pipes leading down the uptake or funnel into another vessel placed in the furnace immediately at the foot of the uptake, to expose the escaping steam to the direct heat of the furnace, for drying and super-heating it before its escape into the air, to render it invisible, substantially as herein specified.
2. The combination in a tramway locomotive of chambers or jackets attached to the boiler pipes, conducting escape steam thereto, and pipes leading from said chambers or jackets to another chamber, within which the steam is expanded a second time before it escapes, substantially as herein specified, to reduce the noise of escaping steam.
3. The combination in a tramway locomotive of chambers or jackets attached to the boiler pipes, leading from the waste-cocks of the engine-cylinders thereto, and pipes leading from said chambers or jackets to another chamber, within which the steam is expanded a second time before it escapes, substantially as herein specified, to prevent noise from escape at said cylinder waste-cocks.
4. The combination in a tramway locomotive of chambers or jackets attached to the boiler pipes, conducting escape steam and water thereto, and pipes leading from said chambers or jackets to a water-tight settling-tank, which collects the separated water, substantially as herein specified, as means for preventing the escape of water.
5. The combination in a tramway locomotive of an automatic governor and a steam or hydraulic brake and valve-reversing gear, operated by said governor, to regulate or check the speed of the locomotive, substantially as herein specified.
6. In a tramway locomotive a vertical boiler constructed with a casing inside the chimney or uptake above the water level, substantially as herein specified for the purpose set forth.
7. In a tramway locomotive having a vertical boiler fitted with "Field" tubes as herein specified, a disc surrounding the uptake above said tubes to prevent scale falling into the latter, substantially as shown.
8. In a tramway locomotive the method of transmission of power by gearing from the rigidly connected driving crank shaft to the traction wheels, to prevent jumping or galloping, substantially as and for the purposes specified.
9. In a tramway locomotive the combination of a vertical boiler on suitable framing, giving shortness of length with chambers for collecting all waste water or steam; a chamber for super-heating the latter in the fire-box; automatic regulating apparatus for breaking and for reversal; chimney casing, scale plate in boiler, and geared driving connections, as, and for the purposes, substantially as specified.

In witness whereof, I, the said William Wilkinson, have hereto set my hand and seal, this sixteenth day of September, 1882.

Witness—

JOHN BRINDLE.

WILLIAM WILKINSON.

This is the specification referred to in the annexed Letters of Registration granted to William Wilkinson, this fifth day of March, A.D. 1883.

AUGUSTUS LOFTUS.

### REPORT.

Sir,

Having examined the drawings and specification accompanying the petition, we have the honor to recommend that Letters of Registration should be issued to William Wilkinson, for an invention entitled "Improvements in Tramway Locomotives," as shown in the drawings and described in the specification attached to his petition.

The Under Secretary of Justice.

Sydney, 16 January, 1883.

We have, &c.,  
JOHN WHITTON.  
E. O. MORIARTY.

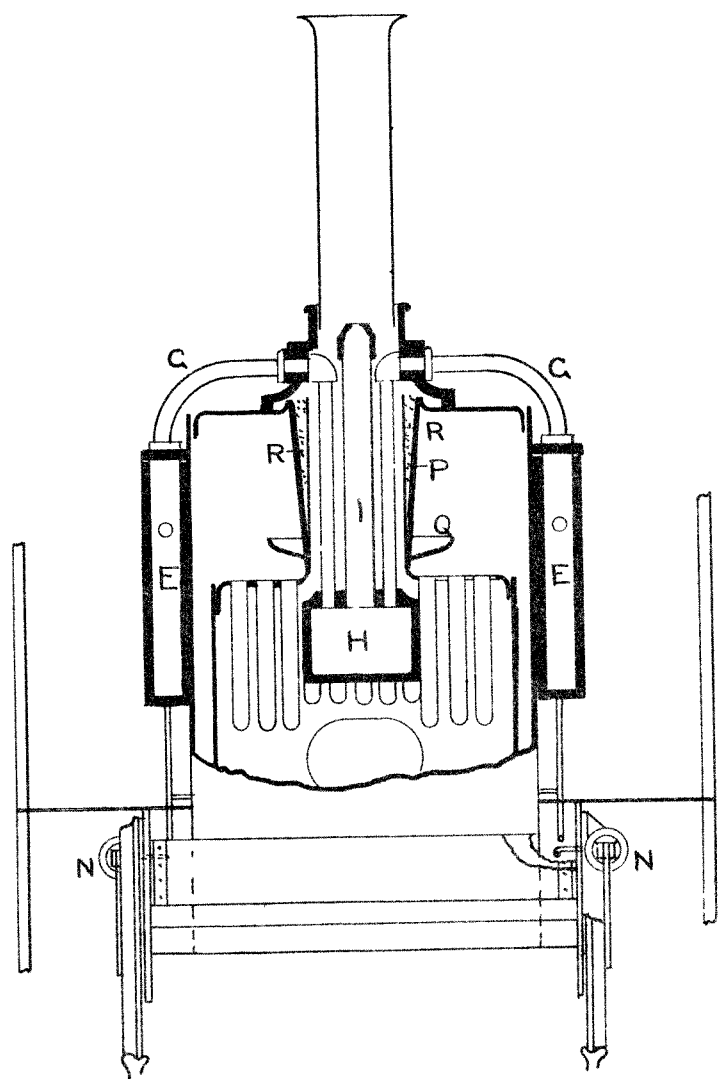


FIG. 2.

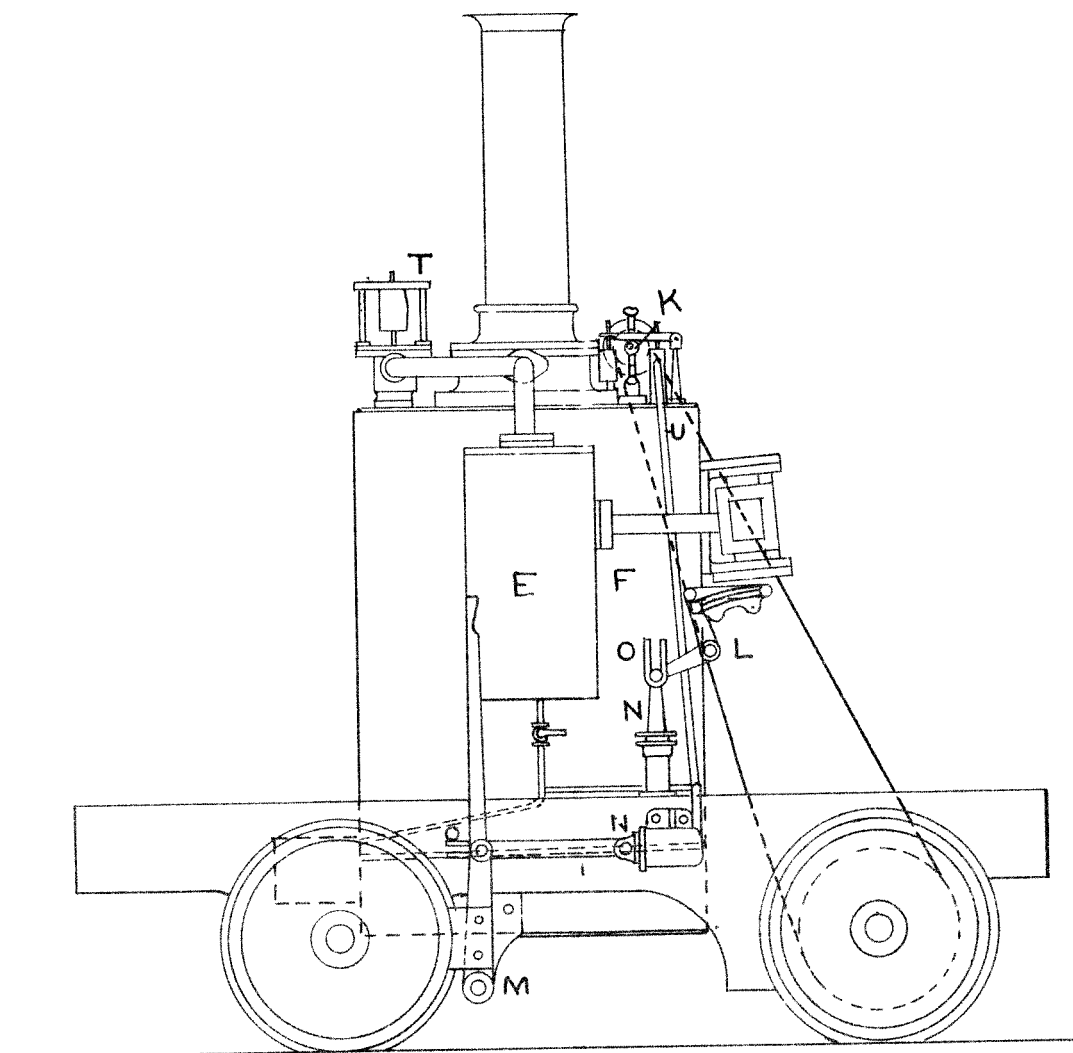


FIG. 1.

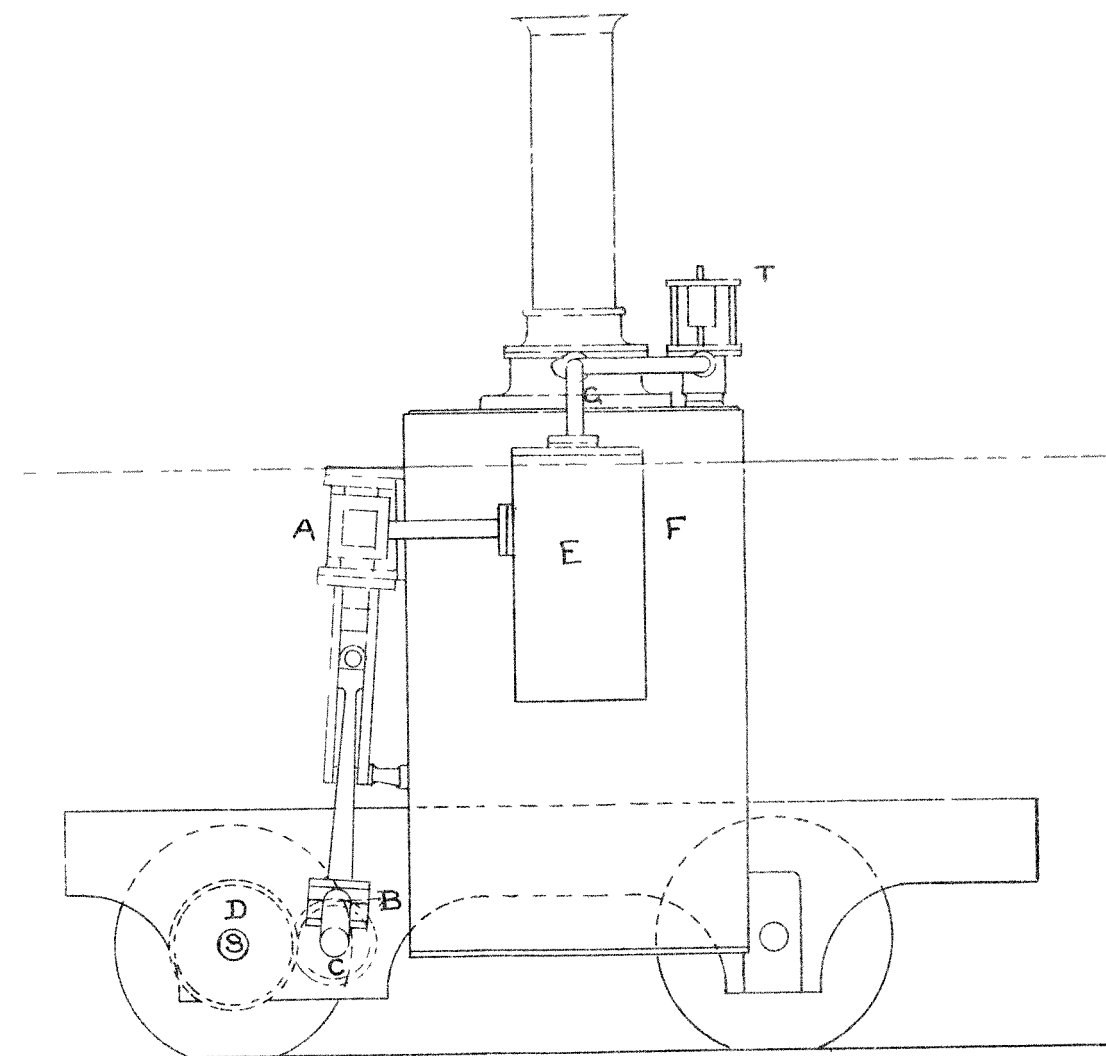


FIG. 3.

*This is the sheet of Drawings referred to in the annexed Letters of Registration granted to William Wilkinson, this fifth day of March, A.D. 1883.*

*Augustus Loftus.*

PHOTO-LITHOGRAPHED AT THE GOVT. PRINTING OFFICE, SYDNEY, NEW SOUTH WALES.

*Sig. 35.*





A.D. 1883, 5th March. No. 1204.

AN IMPROVEMENT IN STAMP BATTERIES.

LETTERS OF REGISTRATION to Robert Scott, for an Improvement in Stamp Batteries.

[Registered on the 6th day of March, 1883, in pursuance of the Act 16 Vic. No. 24.]

BY HIS EXCELLENCY THE RIGHT HONORABLE SIR AUGUSTUS WILLIAM FREDERICK SPENCER LOFTUS (commonly called LORD AUGUSTUS LOFTUS), Knight Grand Cross of the Most Honorable Order of the Bath, a Member of Her Majesty's Most Honorable Privy Council, Governor and Commander-in-Chief of the Colony of New South Wales and its Dependencies.

TO ALL TO WHOM THESE PRESENTS SHALL COME, greeting :

WHEREAS ROBERT SCOTT, of No. 15, Victoria Parade, near Melbourne, in the Colony of Victoria, engineer, hath by his Petition humbly represented to me that he is the author or designer of a certain invention or improvement in manufactures, that is to say, of an invention entitled "An improvement in Stamp Batteries," which is more particularly described in the specification and the sheet of drawings which are hereunto annexed; and that he, the said Petitioner, hath deposited with the Honorable the Treasurer of the said Colony of New South Wales the sum of Twenty Pounds sterling, for defraying the expense of granting these Letters of Registration, as required by the Act of Council, sixteenth Victoria, number twenty-four; and hath humbly prayed that I would be pleased to grant Letters of Registration, whereby the exclusive enjoyment and advantage of the said invention or improvement might be secured to him for a period of fourteen years: And I, being willing to give encouragement to all inventions and improvements in the arts or manufactures which may be for the public good, and having received a report favourable to the prayer of the said Petition, from competent persons appointed by me to examine and consider the matters stated therein and to report thereon for my information, am pleased, with the advice of the Executive Council, and in exercise of the power and authority given to me by the said Act of Council, to grant, and do by these Letters of Registration grant unto the said Robert Scott, his executors, administrators, and assigns, the exclusive enjoyment and advantage of the said invention or improvement, for and during the term of fourteen years from the date hereof; to have, hold, and exercise unto the said Robert Scott, his executors, administrators, and assigns, the exclusive enjoyment and advantage thereof, for and during and unto the full end and term of fourteen years from the date of these presents next and immediately ensuing, and fully to be complete and ended: Provided always, that if the said Robert Scott shall not, within three days after the granting of these Letters of Registration, register the same in the proper office in the Supreme Court, at Sydney, in the said Colony of New South Wales, then these Letters of Registration, and all advantages whatsoever hereby granted, shall cease and become void.

In witness whereof, I have hereunto set my sign manual, and have caused the present Letters of Registration to be sealed with the seal of the said Colony of New South Wales, at Government House, Sydney, in New South Wales, this fifth day of March, in the year of our Lord one thousand eight hundred and eighty-three.

[L.S.]

AUGUSTUS LOFTUS.

*An Improvement in Stamp Batteries.*

SPECIFICATION of ROBERT SCOTT, of No. 15, Victoria Parade, near Melbourne, in the Colony of Victoria, engineer, for an invention entitled "An improvement in Stamp Batteries."

My invention has been designed specially for the purpose of providing those localities with stamp batteries which are difficult of access with heavy articles, but it is also useful in the construction of stamp batteries for any localities, inasmuch as it not only reduces the weight of many of the parts without lessening their efficiency but affords conveniences for driving at different speeds, for stoppages, and for repairs, which are valuable qualities in any stamp battery.

My invention consists in combining a separate engine with each battery. This engine is supported on the horse that usually carries the battery shaft, and its connecting rod is attached to a crank pin on a disc at one end of a counter shaft carrying a fly wheel. At the other end of this shaft is a small toothed pinion driving another and larger toothed wheel at one end of the cam shaft. This method of construction is clearly shown in my drawings, in which figure 1 shows front elevation, figure 2, side elevation, and figure 3, plan of a battery constructed according to my invention, in which A is the engine cylinder, A' its connecting rod, B crank pin on disc B' at one end of shaft B<sup>2</sup>, which also carries fly wheel B<sup>3</sup> and spur pinion B<sup>4</sup> driving toothed wheel C on cam shaft C<sup>1</sup>.

Of course there may be a greater or less number of stamps in each battery than I have shown, and there may be one battery alone or a number of them combined together. I prefer to use a tubular boiler for generating steam when the battery or batteries are in a locality difficult of access, but under other circumstances I should use the ordinary shell boiler. As a matter of economy and convenience, I should also supply all the engines with steam from one boiler, but of course that is not a matter of necessity.

The advantage of this method of construction will be obvious to any practical man. By it the weight of the shafting, fly wheels, gearing, framing, foundations, &c., can be greatly reduced, and so the cost not only of construction but of working materially lessened, independently of which each battery can be driven at the speed and with the length of drop which best suits the material it is treating, and each can be stopped for repairs or otherwise without in the least affecting any of the others.

Having thus described the nature of my invention and the manner of performing same, I would have it understood that what I believe to be new and therefore claim as my improvements in stamp batteries, is:—

The combination of direct acting engines with stamp batteries in the manner and for the purpose substantially, as herein described and explained, and as illustrated in my drawings.

In witness whereof, I, the said Robert Scott, have hereunto set my hand and seal, this fourth day of January, one thousand eight hundred and eighty-three.

R. SCOTT.

Witness—

EDWD. WATERS,  
Melbourne, Patent Agent.

This is the specification referred to in the annexed Letters of Registration granted to Robert Scott, this fifth day of March, A.D. 1883.

AUGUSTUS LOFTUS.

---

REPORT.

Sir,

Sydney, 15 January, 1883.

We do ourselves the honor to report, in reply to your blank cover communication of the 9th instant, No. 441, we are of opinion the prayer of Mr. Robert Scott's Petition for the registration of "An improvement in Stamp Batteries" may be granted in terms of his specification, drawings, and claim.

We have, &c.,

E. C. CRACKNELL.  
GOTHER K. MANN.

The Under Secretary of Justice.

---

[Drawings—one sheet.]

R. SCOTT'S PATENT.

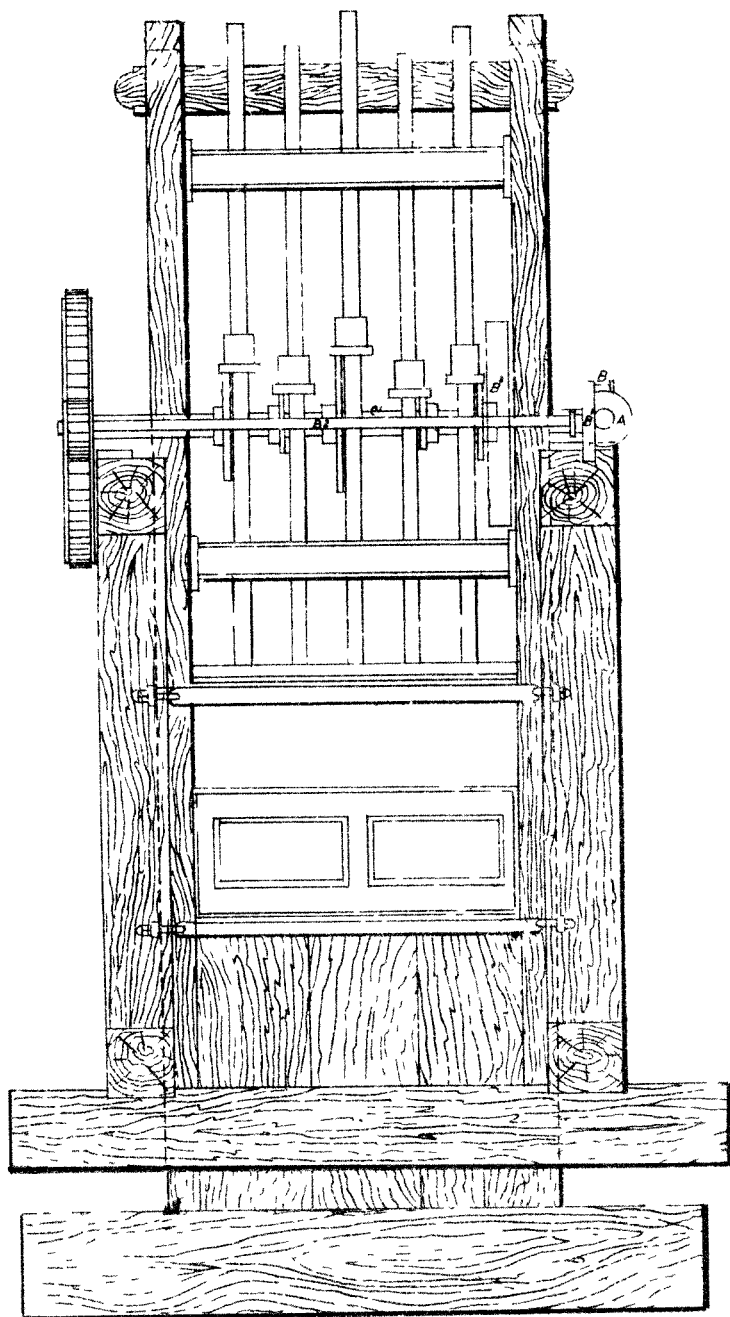


Fig. 1.

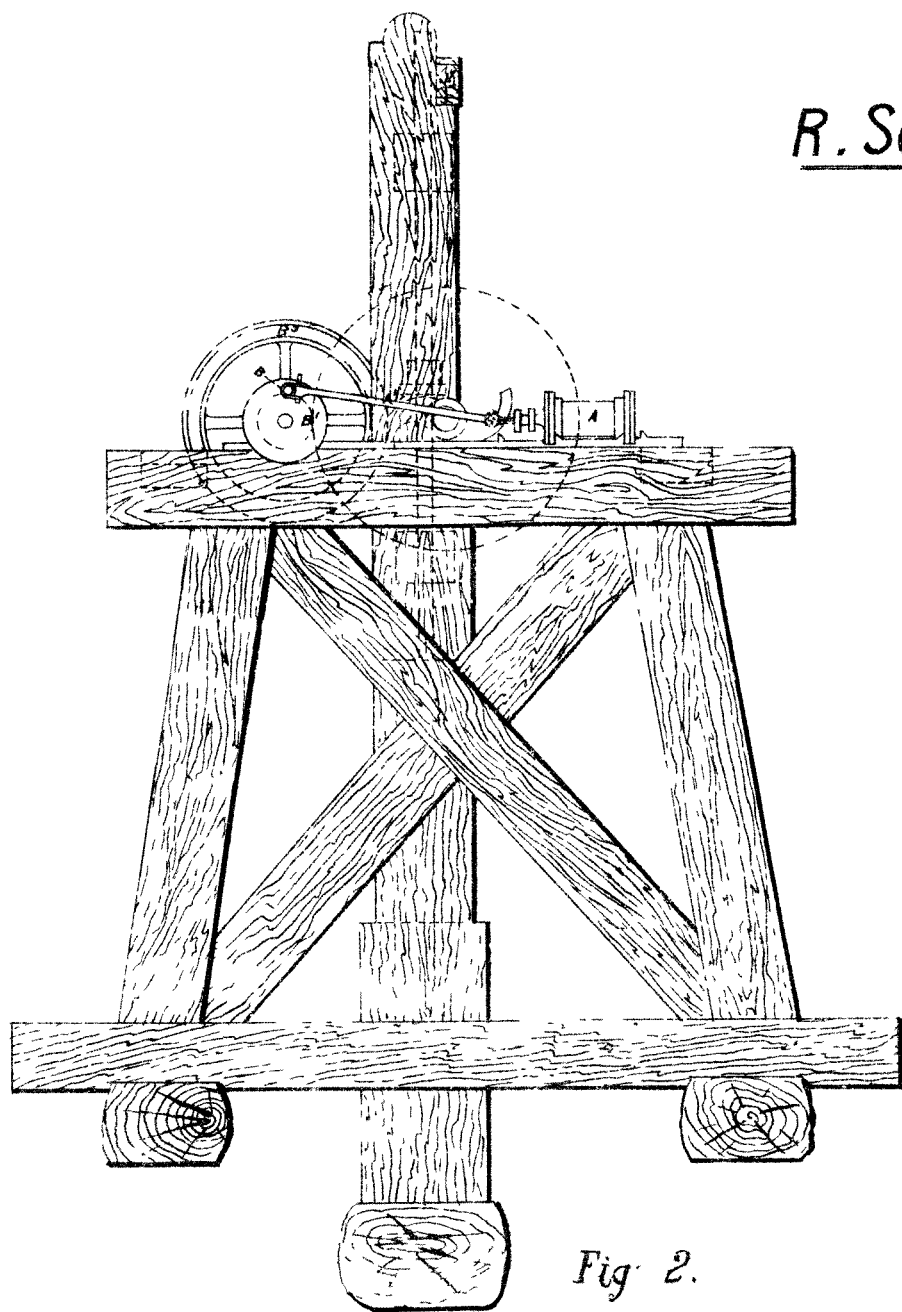


Fig. 2.

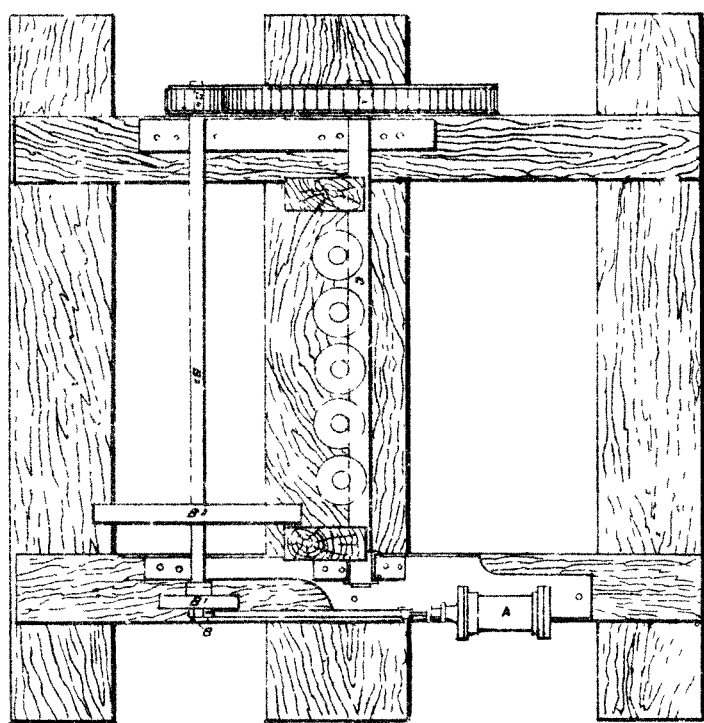


Fig. 3.

*This is the Sheet of Drawings referred to in the annexed Letters of Registration granted to Robert Scott, this fifth day of March, A D 1883.*

*Augustus Loftus.*

PHOTO-LITHOGRAPHED AT "THE GOVT. PRINTING OFFICE" SYDNEY, NEW SOUTH WALES

*Fig. 3.*



A.D. 1883, 5th March. No. 1205.

IMPROVEMENTS IN THE PERMANENT-WAY OF RAILWAYS.

LETTERS OF REGISTRATION to Fridolf Schauman, for Improvements in the Permanent-way of Railways.

[Registered on the 6th day of March, 1883, in pursuance of the Act 16 Vic. No. 24.]

BY HIS EXCELLENCY THE RIGHT HONORABLE SIR AUGUSTUS WILLIAM FREDERICK SPENCER LOFTUS (commonly called LORD AUGUSTUS LOFTUS), Knight Grand Cross of the Most Honorable Order of the Bath, a Member of Her Majesty's Most Honorable Privy Council, Governor and Commander-in-Chief of the Colony of New South Wales and its Dependencies.

TO ALL TO WHOM THESE PRESENTS SHALL COME, greeting :

WHEREAS FRIDOLF SCHAUMAN, railway director in Sweden, hath by his Petition humbly represented to me that he is the author or designer of a certain invention or improvement in manufactures, that is to say, of an invention entitled "Improvements in the Permanent-way of Railways," which is more particularly described in the specification and the sheet of drawings which are hereunto annexed; and that he, the said Petitioner, hath deposited with the Honorable the Treasurer of the said Colony of New South Wales, the sum of Twenty Pounds sterling, for defraying the expense of granting these Letters of Registration, as required by the Act of Council, sixteenth Victoria, number twenty-four, and hath humbly prayed that I would be pleased to grant Letters of Registration, whereby the exclusive enjoyment and advantage of the said invention or improvement might be secured to him for a period of fourteen years: And I, being willing to give encouragement to all inventions and improvements in the arts or manufactures which may be for the public good, and having received a report favourable to the prayer of the said Petition, from competent persons appointed by me to examine and consider the matters stated therein and to report thereon for my information, am pleased, with the advice of the Executive Council, and in exercise of the power and authority given to me by the said Act of Council, to grant, and do by these Letters of Registration grant unto the said Fridolf Schauman, his executors, administrators, and assigns, the exclusive enjoyment and advantage of the said invention or improvement, for and during the term of fourteen years from the date hereof; to have, hold, and exercise unto the said Fridolf Schauman, his executors, administrators, and assigns, the exclusive enjoyment and advantage thereof for and during and unto the full end and term of fourteen years from the date of these presents next and immediately ensuing, and fully to be completed and ended: Provided always, that if the said Fridolf Schauman shall not within three days after the granting of these Letters of Registration, register the same in the proper office in the Supreme Court, at Sydney, in the said Colony of New South Wales, then these Letters of Registration, and all advantages whatsoever hereby granted, shall cease and become void.

In witness whereof, I have hereunto set my sign manual, and have caused the present Letters of Registration to be sealed with the seal of the said Colony of New South Wales, at Government House, Sydney, in New South Wales, this fifth day of March, in the year of our Lord one thousand eight hundred and eighty-three.

[L.S.]

AUGUSTUS LOFTUS.

*Improvements in the Permanent-way of Railways.*

SPECIFICATION OF FRIDOLF SCHAUMAN, railway director in Sweden, for an invention entitled "Improvements in the Permanent-way of Railways."

THE object of my invention is to obtain a durable, elastic, and safe permanent-way; it consists in the employment of stone or concrete sleepers, with washer-plates of compressed or prepared cork as an elastic medium between the rails and the said stone or concrete sleepers, the said rails and compressed or prepared cork washer-plates being fixed to the stone or concrete sleepers by means of bolts and nuts and spring clip-plates.

In the accompanying drawings, figure 1 shows a cross-section of the stone sleeper, the compressed or prepared cork washer-plate, the screw-bolts, with the nuts and spring clip-plates, and the rail. Figure 2 shows a plan of figure 1. Figures 3 and 4 show respectively in elevation and plan the application of this invention to the ordinary chair and rail. Figure 5 shows an elevation of a piece of permanent-way constructed in accordance with the said improvements. Figure 6 a plan, and figure 7 a cross section of the same; and figures 8, 9, and 10 an elevation, plan, and cross section of a similar piece of permanent-way, but with another form of stone or concrete sleeper.

The stone or concrete sleepers *a* are laid in the ballast of the road, and are each furnished with four bored or cast bolt holes, through which pass wrought iron bolts, *c*, with hooks or heads at their lower ends, and nuts, *e*, at their screwed upper ends.

The compressed or prepared cork washer-plates, *b*, are placed at or near the edges of the stone or concrete sleepers, *a*, and so that the aforesaid bolts, *c*, also pass through holes formed in them corresponding to the holes in the said sleepers.

The rails, *f*, which are of a flat-bottomed section, are laid on these compressed or prepared cork washer-plates, *b*, and are secured thereto and to the sleepers by spring clip-plates, *d*, of suitable form and dimensions, which are adapted to bear at one end on the upper side of the foot of the rail, and at the other end on the compressed or prepared cork washer-plates, *b*, the aforesaid bolts, *c*, pass through holes in such spring clip-plates, *d*, and the nuts, *e*, of the said bolts when tightened up bear upon the said spring clip-plates and hold the rails, *f*, the cork washer-plate, *b*, and the stone or concrete sleepers, *a*, firmly together.

The compressed or prepared cork washer-plates and stone or concrete sleepers are also applicable to the ordinary chair and rail, as shown in figures 3 and 4, *f* being an ordinary rail, *d* the chair, *h* the wooden wedge, *b* the compressed or prepared cork washer-plate, *a* the stone or concrete sleeper, *c* the bolt, and *e* the nuts.

The desired width between the rails is secured by iron cross ties, *g*.

Figures 1 and 2 are shown to  $\frac{2}{3}$  of natural size.

Figures 3 and 4 "  $\frac{1}{2}$  "

Figures 5 to 10 "  $\frac{1}{30}$  "

By reducing or increasing the thickness of the compressed or prepared cork washer-plates, *b*, the road can readily be adjusted.

Having now described the nature of the said invention, and the manner in which the same is to be carried into effect, I would have it understood that what I claim is—

In the construction of the permanent-way of railways the employment of stone or concrete sleepers with compressed or prepared cork washer-plates, interposed between such sleepers and the rail, the said rail and the compressed or prepared cork washer-plates being secured to the said stone or concrete sleepers by screw bolts and nuts and spring clip-plates, the whole arranged and combined as hereinbefore described and illustrated in the drawings hereto annexed, and for the purposes set forth.

In witness whereof, I, the said Fridolf Schauman, have hereto set my hand and seal, this third day of August, in the year of our Lord 1882.

Witness—

LORENTZ ALBERT GROTH.  
HENRY THOMAS DAVEY.

FRIDOLF SCHAUMAN.

This is the specification referred to in the annexed Letters of Registration granted to Fridolf Schauman, this fifth day of March, A.D. 1883.

AUGUSTUS LOFTUS.

### REPORT.

Sir,

Having examined the drawings and specification accompanying the Petition, we have the honor to recommend that Letters of Registration should be issued to Mr. Fridolf Schauman, for an invention entitled "Improvements in the Permanent-way of Railways," as shown in the drawings and described in the specification attached to his Petition.

The Under Secretary of Justice.

Sydney, 16 January, 1883.

We have, &c.,

JOHN WHITTON.  
E. O. MORIARTY.

FIG. 1

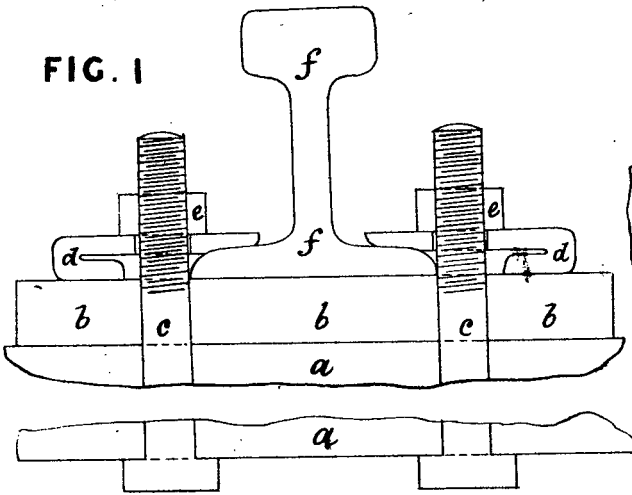


FIG. 2

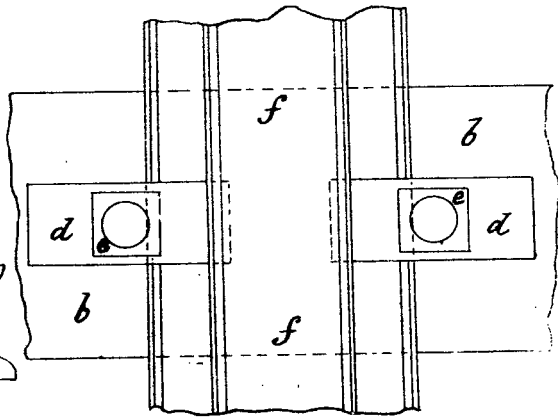


FIG. 3

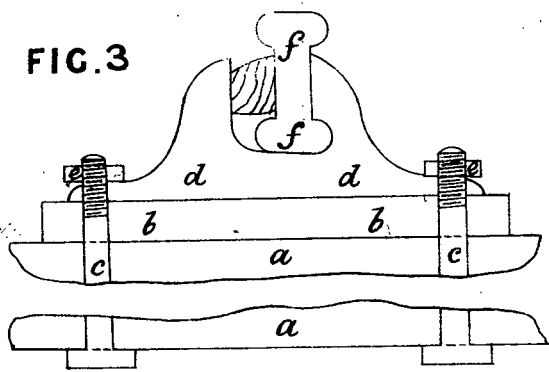


FIG. 4

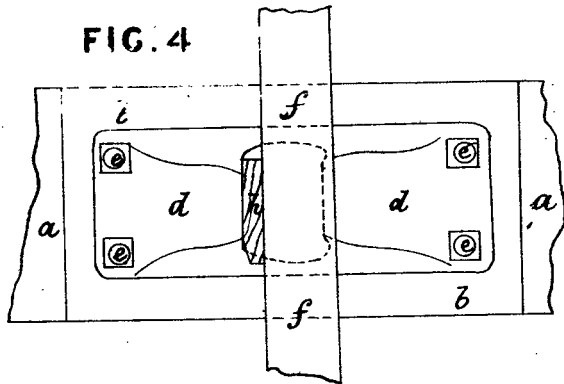


FIG. 5



FIG. 8



FIG. 6

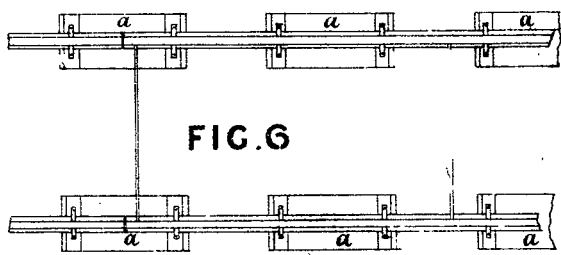


FIG. 9

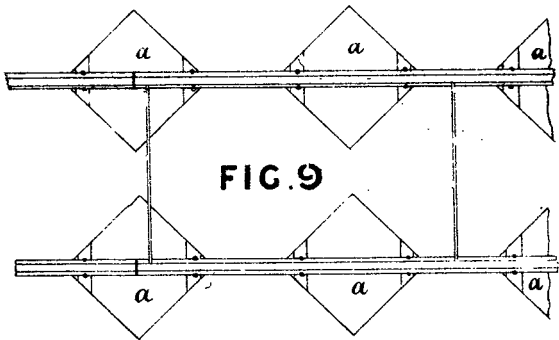
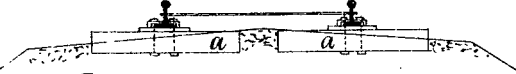


FIG. 7



FIG. 10



*This is the Sheet of Drawings referred to in the annexed Letters of Registration granted to Fridolf Schawman, this fifth day of March, A. D. 1883.*

*Augustus Loftus.*



A.D. 1883, *5th March*. No. 1206.

IMPROVEMENTS FOR INDICATING AND REGULATING THE CURRENT OF  
ELECTRICAL GENERATORS, &c.

LETTERS OF REGISTRATION to Thomas Alva Edison, for Improvements in means for Indicating and Regulating the Current of Electrical Generators for supplying Electric Lights and other purposes.

[Registered on the 6th day of March, 1883, in pursuance of the Act 16 Vic. No. 24.]

BY HIS EXCELLENCY THE RIGHT HONORABLE SIR AUGUSTUS WILLIAM FREDERICK SPENCER LOFTUS (commonly called LORD AUGUSTUS LOFTUS), Knight Grand Cross of the Most Honorable Order of the Bath, a Member of Her Majesty's Most Honorable Privy Council, Governor and Commander-in-Chief of the Colony of New South Wales and its Dependencies.

TO ALL TO WHOM THESE PRESENTS SHALL COME, greeting :

WHEREAS THOMAS ALVA EDISON, of Menlo Park, New Jersey, United States of America, electrician, hath by his Petition humbly represented to me that he is the author or designer of a certain invention or improvement in manufactures, that is to say, of an invention entitled "Improvements in means for Indicating and Regulating the Current of Electrical Generators for supplying Electric Lights and other purposes," which is more particularly described in the specification, marked A, and the two sheets of drawings, marked B and C respectively, which are hereunto annexed; and that he, the said Petitioner, hath deposited with the Honorable the Treasurer of the said Colony of New South Wales the sum of Twenty Pounds sterling, for defraying the expense of granting these Letters of Registration, as required by the Act of Council, sixteenth Victoria, number twenty-four; and hath humbly prayed that I would be pleased to grant Letters of Registration, whereby the exclusive enjoyment and advantage of the said invention or improvement might be secured to him for a period of fourteen years: And I, being willing to give encouragement to all inventions and improvements in the arts or manufactures which may be for the public good, and having received a report favourable to the prayer of the said Petition, from competent persons appointed by me to examine and consider the matters stated therein and to report thereon for my information, am pleased, with the advice of the Executive Council, and in exercise of the power and authority given to me by the said Act of Council, to grant, and do by these Letters of Registration grant unto the said Thomas Alva Edison, his executors, administrators, and assigns, the exclusive enjoyment and advantage of the said invention or improvement, for and during the term of fourteen years from the date hereof; to have, hold, and exercise unto the said Thomas Alva Edison, his executors, administrators, and assigns, the exclusive enjoyment and advantage thereof, for and during and unto the full end and term of fourteen years from the date of these presents next and immediately ensuing, and fully to be complete and ended: Provided always, that if the said Thomas Alva Edison shall not, within three days after the granting of these Letters of Registration, register the same in the proper office in the Supreme Court, at Sydney, in the said Colony of New South Wales, then these Letters of Registration, and all advantages whatsoever hereby granted, shall cease and become void.

In witness whereof, I have hereunto set my sign manual, and have caused the present Letters of Registration to be sealed with the seal of the said Colony of New South Wales, at Government House, Sydney, in New South Wales, this fifth day of March, in the year of our Lord one thousand eight hundred and eighty-three.

[L.S.]

AUGUSTUS LOFTUS.

*Improvements for indicating and regulating the current of Electrical Generators, &c.*

## A.

SPECIFICATION of THOMAS ALVA EDISON, of Menlo Park, New Jersey, United States of America, electrician, for an invention entitled "Improvements in means for indicating and regulating the current of Electrical Generators for supplying Electric Lights and other purposes."

THE said invention relates to improved means for indicating and regulating the current of dynamo- or magneto-electric machines for supplying electric lights and other purposes.

One part of the invention has reference to the combination with one or more electrical generators having a multiple arc field circuit and supplying lamps or other translating devices located in derived or multiple arc circuits, of an alarm or indicator operated by the current generated and indicating variations of candle-power above or below, or both above and below, the desired limit, such alarm or indicator being controlled by an electro-magnet, also located in a multiple arc circuit.

This part of the invention is illustrated in figure 1, and chiefly on the left hand of that figure.

A represents a dynamo or magneto-electric machine, 1 2 the main or consumption circuit, and *a a* incandescing lamps in multiple arc or derived circuits; 3 4 represents a multiple arc or derived circuit from 1 2, with resistance R and the coils of an electro-magnet, B, placed therein, the resistance being many times more than that of one of the lamp circuits. From 3 4 is a shunt, 5 6, around the resistance R. The armature lever C retracted by spring *b* is in this circuit. Front and back contacts *c c'* are connected with the spring *d* of the vibrating bell mechanism, which consists of an electro-magnet, *e*, an armature lever, *f*, forming the bell-hammer, and a gong, *g*, the making of each of which contacts completes a circuit through the bell-hammer vibrator. Resistances R<sup>1</sup> R<sup>2</sup> are arranged in the bell circuit, resistance R<sup>1</sup> being in the circuit of each contact, *c c'*, whilst R<sup>2</sup> is only in the circuit of the back contact, *c'*, so that alarms varying noticeably in their loudness will be produced. A yielding stop-arm, C<sup>1</sup>, is placed between lever C and front contact *c*, and is drawn back by a spring, *b'*, against a fixed pin, *b''*, this yielding stop, the use of which is of considerable importance, determining the central position of the armature lever. R<sup>3</sup> represents resistance in the field circuit 9 10, which resistance is cut in and out of circuit by the act of moving the lever *r* in one direction or the other.

When the lamps are at the normal candle-power the magnet B will not be strong enough to overcome both retractile springs *b* and *b'*, and the lever C will stand in a central position held against the stop-arm C<sup>1</sup>, and keeping open both circuits through the bell mechanism, as shown in the drawing. Any increase in the electro-motive force that will raise the lamps to higher incandescence will strengthen B, which will attract C, and force C<sup>1</sup> upon contact *c*, completing the circuit of lower resistance through the vibrating bell and causing it to strike a loud alarm.

The operator will then move the lever *r* so as to throw resistance into the field circuit 9 10, or regulate the machine in any other known manner, and produce the normal condition of the current, when B will weaken, allowing C to again assume a central position, breaking the bell circuit. When there is a drop in the electro-motive force and the lamps are reduced in candle-power the magnet B will further weaken, and the spring *b* will draw it against contact *c'*, closing the circuit of higher resistance through the bell mechanism, and causing it to strike a noticeably weaker alarm than when the circuit is closed at contact *c*. The operator then moves lever *r* throwing resistance out of the field circuit, or otherwise regulates the machine in any known manner, and increases the electro-motive force to the normal condition, when C will again assume a central position, as shown in the drawing, breaking the circuit of the bell mechanism.

It is evident that in lieu of using a single vibrating bell with two circuits having different resistances two bells may be used, in which case the bell circuits may have different resistance, or the circuits may have the same resistance, and the bells be constructed to give sounds of different pitch, or both features may be combined.

Instead of bell alarms alone, an indicator may be used consisting of a pointer travelling upon a scale to right or left, and operated by the armature lever of the electro-magnet in the multiple arc circuit, and in connection with the indicator an alarm may be arranged to strike when the pointer reaches a certain point on either side of its normal position.

The apparatus may be otherwise modified whilst still retaining the arrangement of the controlling electro-magnet located in a multiple arc circuit and its appurtenances, as hereinbefore described. For example, a device similar to a galvanometer may be employed to make and break the alarm circuits. In this case the armature lever of the controlling electro-magnet closes at front and back contacts circuits through two sets of coils within which is pivoted a heavy magnetized needle, the movement of which makes and breaks the circuits.

On the right-hand side of the same figure (1) are shown devices arranged according to this invention for preventing injury to the machine when an abnormally large current is caused to flow by the addition of more lights than the plant has capacity to furnish, and notifying the engineer of the condition of affairs.

In this figure D is a piece of safety catch or fusible wire or material placed in 1 or 2 (it being shown as placed in 2 in the example illustrated) between the lamps and the machine A. This safety catch is of such size and character that when more lamps are put in circuit than the plant is designed to furnish, and before the machine or machines are injured by the abnormally large flow of current, it will burn out and break the circuit between the generator and the translating devices. In a shunt, 7 8, around D are arranged a resistance, R<sup>3</sup>, and a vibrating bell composed of an electro-magnet, *h*, a spring, *i*, a bell-hammer, *k*, and a gong, *l*.

When the safety catch D is intact little or no current passes through the shunt circuit 7 8, and the bell mechanism is not operated, the resistance being sufficient under normal conditions to prevent its action.

An abnormal and dangerous flow of current will burn out the safety catch, when the current will be thrown through the bell mechanism and will operate the same, giving an alarm.

If the abnormal flow of current is caused by a larger number of lamps than the machine is intended to carry, the operator will remove or break the circuits of a number of lamps, and will then replace the safety catch.

The



*Improvements for indicating and regulating the current of Electrical Generators, &c.*

The two classes of alarms or apparatus hereinbefore described are especially adapted for use in "isolated work" or with plant for lighting separate buildings or small areas, but they are also useful with other translating devices besides lamps to show corresponding conditions.

In order to obviate the necessity for the engineer adjusting the machine by hand as before referred to, for the purpose of regulating the generation of current by the machine, this operation may be performed automatically, the current generated being itself caused to operate mechanism which will vary the resistance in the field of force circuit, or shift round the commutator brushes or springs. Figures 2 and 3 illustrate apparatus constructed and arranged according to this invention for this purpose, the former (figure 2) operating by varying the resistance in the field of force circuit, and the latter (figure 3) by shifting round the commutator brushes or springs.

Referring to figure 2, A is a dynamo-electric machine, from which lead the main conductors 1 2, of a multiple arc system; 3 4, is a multiple arc circuit including the field magnets of the dynamo.

The wire 4 includes the circular adjustable resistance B, while the wire 3 terminates in a pivoted contact arm, *a*, adapted to make contact with the points *b b* of the resistance B.

5 6 is another multiple arc circuit, including an electro-magnet, C, and a resistance, D. Around the latter is formed a shunt circuit, 7 8, which is divided into two circuits, 9 *x c* and 9 *x' d*, *c* and *d* being contact points.

Either or both of the wires 7, 8 may, if desired, be made adjustable, so that they may be connected with different parts of the resistance D, and thus shunt more or less current into the circuit 7 8.

The magnet C is provided with an armature, E, pivoted at *e*, and forming part of the circuit 7 8; at its free end it is provided with two contact points, one on each side. The armature has also a spring, *f*, whose tendency is to withdraw it from the magnet C. A pivoted spring arm, *g*, is so placed that normally it is midway between *c* and *d* (being prevented from moving in one direction by a stop, *y*), but it may be pressed over by the armature, so as to contact with *c* and close the circuit 9 *x c*. When the pressure is removed the current is broken, and the armature E assumes and is retained in a central position until the magnet becomes so weak that the armature is drawn back against *d*, and closes the circuit 9 *x' d*.

The circuit 9 *c* includes a magnet, F, having an armature, G, pivoted at *h* and retracted by a spring, *i*.

The lower end of the armature enters between the sides of the U-shaped metal piece *k*, which is pivoted at *l* and placed between stops *m n*; the wire *x* is attached at *b* and the wire 9 to the stop *n*, so that when *k* is thrown against *n* the circuit 9 *x c* is closed at this point, and when it is thrown against *m* the circuit 9 *x c* is opened. A ball or weight, *o*, assists the motion of the piece *k*. Thus the movement of the armature G causes the make and break of circuit, and the armature is caused to vibrate.

At the other end of the armature G is pivoted a pawl, H, which, when the armature G vibrates, moves the ratchet wheel *r* and turns the contact arm *a*, so that it places more of the resistance B in the circuit 3 4.

A similar arrangement is placed on the opposite side of the resistance, F<sup>1</sup> being the magnet, G<sup>1</sup> its armature pivoted at *h*<sup>1</sup>; *k*<sup>1</sup> the U-shaped circuit reverser; *i*<sup>1</sup>, *l*<sup>1</sup>, *m*<sup>1</sup>, *n*<sup>1</sup>, *o*<sup>1</sup> parts corresponding to the parts *i*, *l*, *m*, *n*, *o* respectively, hereinbefore described as appertaining to the circuit 9 *x c*, and H<sup>1</sup> the pawl, actuating the ratchet wheel *r*<sup>1</sup>, so that the contact arm *a* is turned the opposite direction, and cuts out instead of putting in resistance.

The apparatus operates in the following manner, viz. :—

When the current is normal, and the candle-power of the lamps is at the desired point, the lever E will be held in a central position by the means hereinbefore described, breaking both divisions of the shunt circuit 7 8.

An increase in the electro-motive force of the current will cause the magnet C to draw the armature lever E against the contact *c*, completing the division of the shunt through the magnet F. Lever G will then be vibrated, the circuit being alternately made and broken by the retractile force of the spring *i* and the attraction of the magnet acting on the lever G, and through it on the U-shaped piece *k*. The pawl H being thus actuated the contact arm *a* is moved so as to throw resistance into the field circuit. The normal electro-motive force having been restored, magnet C weakens, and lever E assumes a central position, and the vibrating apparatus will be at rest.

When there is a decrease in the electro-motive force magnet C will further weaken, allowing E to make contact with *d*, and closing the circuit through F<sup>1</sup>. Lever G<sup>1</sup> will be vibrated in a similar manner to lever G, as hereinbefore described, moving arm *a* in the opposite direction and cutting resistance out of the field circuit. This is the position of the parts indicated in the drawing, the pawl H<sup>1</sup> having advanced; acting upon the ratchet wheel *r*<sup>1</sup>, after which it will be drawn back by means of the spring *i*<sup>1</sup> acting upon the lever G<sup>1</sup>, and the circuit being by this act again established the pawl will be again advanced, and so on in succession until the normal electro-motive force is restored, when the lever E will again assume a central position, and the vibrating apparatus will be at rest.

It should be observed that the employment of devices for maintaining the lever E of the controlling magnet in a central position when the electro-motive force is normal is a feature of considerable importance. In this mechanism, as without such devices it is impossible to prevent the lights from flickering, owing to the incessant vibration of the said lever.

It is evident that the arrangements illustrated in figures 1 and 2 are equally applicable to magneto- and to dynamo-electric machines; and to a battery or number of machines, as well as to a single machine.

Referring to figure 3, the main conductors 1 2, run from the commutator brushes *a*, which are carried by arms C, secured to the pivoted yoke *b*, but insulated therefrom by bushings *d*.

A worm wheel, *e*, is secured to the yoke *b*, and engages with a worm, *e*<sup>1</sup>, secured to two ratchet wheels, *f f*<sup>1</sup>, having teeth respectively tending in opposite directions; D D<sup>1</sup> are electro-magnets, the armature levers *h h*<sup>1</sup> of which carry pawl arms *g g*<sup>1</sup> engaging respectively with *f f*<sup>1</sup>. These levers which are pivoted at *m m*<sup>1</sup> are retracted by springs *l l*<sup>1</sup>. They are extended below their pivots and serve to throw Y-shaped circuit controllers *n n*<sup>1</sup>, the action being assisted by springs *s s*<sup>1</sup> or weights. In a multiple arc circuit 7 8 are a controlling electro-magnet E and resistance G. The adjustable shunt 5 6 runs to the armature lever F and to the Y-shaped circuit controllers *n n*<sup>1</sup>. The front and back contacts *i i*<sup>1</sup> of F are connected with D D<sup>1</sup>, which are also connected with the front contacts *o o*<sup>1</sup> of the circuit controllers *n n*<sup>1</sup>. The spring-arm *p* and stop *p*<sup>1</sup> determine the central position of F. The

*Improvements for indicating and regulating the current of Electrical Generators, &c.*

The apparatus operates in the following manner:—

When the electro-motive force of the current in 1 2 is normal, and the candle-power of the lamps is at the desired point, the lever E will be held in a central position, breaking both divisions of the shunt 5, 6, as shown in the drawings. An increase in the electro-motive force will cause the magnet E to strengthen and draw F against *z*, closing the circuit through D. The lever *h* is then caused to vibrate, the circuit being alternately broken by the electro-magnet attracting the lever *h*, and thus throwing over the circuit controller *n* to one side, and made by the retractile action of the spring *l*, drawing back the lever *h*, and thus throwing the circuit controller *n* to the opposite side. The vibration of this lever through the pawl arm *g*, and ratchet wheel *f*, the worm *e'*, and the worm wheel *e*, will move the brushes away from the line of maximum generation, until the normal candle-power is restored, when lever F will assume a central position under the action of the devices, hereinbefore described. A decrease in electro-motive force will weaken E further, allowing F to rest upon the contact *z'*, and closing the circuit through D'. This will have the effect of vibrating lever *h*, which, through the pawl *g'*, and ratchet wheel *f'*, and the worm gear, will adjust the commutator brushes towards the line of maximum generation. The restoration of the normal candle-power will cause F to again assume a central position, as shown in the drawing, breaking both divisions of the shunt, and making both vibrating motors inactive.

It should be observed that in practice it is found indispensable to use means for determining the central position of the lever F, under approximately normal conditions of the current, as otherwise a flickering and unsteadiness in the lights will result.

In lieu of employing the vibrating mechanisms hereinbefore described, a single revolving electro-motor may be used to shift the brushes, the direction of revolution of the motor armature being changed by reversing the polarity of the current flowing through the field circuit, whilst the current is caused to always flow in the same direction through the armature coils, and the current reverser being controlled by an electro-magnet located in a multiple arc or derived circuit.

Or two revolving electro-motors may be used connected in a similar manner to the vibrating mechanisms in the apparatus hereinbefore described with reference to figure 3, so as to be controlled in their motion by an electro-magnet which is located in a multiple arc or derived circuit, and arranged so as to operate in the manner hereinbefore described.

When the lamps or other translating devices are divided into groups, the lamps of each group being those that are in multiple arc or derived circuits from the same pair of conductors branching from the main conductors, I provide in connection with each group means for regulating the current energizing the field magnet of the machine operated by the current generated and acting automatically upon the addition or removal of translating devices in the group. This is illustrated in figures 4 and 5 of the drawings.

A is the generator, and 1, 2 the main conductors from the same. The lamps or other translating devices, *a*, are in multiple arc circuits from pairs of branching conductors 5 6, 7 8, 9 10, any number of which branching conductors may be used.

In one of the conductors of each pair of branching conductors is placed an electro-magnet, B, provided with an armature *f*.

In figure 4 the field circuit is a multiple arc circuit, 3 4, provided with a number of resistances, R, R', R'', there being one set of resistances for each pair of branching conductors. There are shunt circuits, *b*, *e*, *d*, around these resistances to the armature levers *f* and their front contacts *z*, by the opening or closure of each of which circuits by its respective electro-magnet B the energy of the field magnet is diminished or increased.

In lieu of cutting out and throwing in resistance the electro-magnets may be used to close and open additional field circuits. This modification is illustrated in figure 5. The field circuit is a divided circuit, three circuits 3*g*, 3*h*, 3*k*, being shown in the example illustrated. Circuit 3*g* is constantly closed; circuits 3*h* 3*k* are opened and closed by the movement of the armature levers *f* from and to their front contacts *z*, thus varying the energy of the field magnet as before.

The apparatus operates in the following manner, videlicet:—When there are few lamps in circuit, not sufficient to enable the electro-magnets B to attract their armature levers *f*, the minimum current will flow through the field circuit. In the construction shown in figure 4 the current will flow through all the resistances, R, R', and R'', while in the construction shown in figure 5 it will flow only through the constantly closed division 3*g* of the field circuit. After a definite number of lamps has been added to any particular group (for example, the group in circuit 7 8) the magnet, B, of that group will have sufficient strength to draw the lever *f* against its front contact *z*. This will cut the resistance R' out of the field circuit in the modification figure 4, and close the additional field circuit 3*k* in figure 5, as shown in the drawings. The field magnet will be strengthened and the electro-motive force of the machine increased to the desired extent for supplying all the lamps of the grouping, 7 8.

As the lamp circuits are broken, the magnet B will weaken, until *f* separates from its front contact *z*, when the resistance R' will be thrown into the field circuit in the modification figure 4, and the circuit 3*k* (figure 5) will be opened, the electro-motive force being thereby decreased. This operation occurs in connection with each group of lamps. I may also regulate the current energizing the field magnet of the generator by the employment of a series of devices operated by the current generated arranged to act successively as more translating devices are placed in circuit to increase the current energizing the field magnet, and also acting successively as translating devices are taken out of circuit to decrease the current energizing the field magnet. These devices act to open and close circuits throwing in or out resistance or opening and closing additional field or force circuits. Figures 6 to 10 inclusive illustrate examples of the manner in which this modification may be carried out.

D is the generator, 1, 2 the main conductors therefrom and *e* the translating devices placed in multiple arc or derived circuits.

A, B, C, are electro-magnets having armature levers, *c*, *c'*, *c''*; these are retracted by springs, *d*, *d'*, *d''* (figures 6, 7, 9 and 10), or by weights, *f*, *f'*, *f''* (figure 8), which are made of graduated power, or the armatures may be placed at different distances from the magnets, or the latter may be wound differently, or the relation between the magnets and their armatures may be graduated in any other suitable manner, so that the armature levers will be moved in succession. These

*Improvements for indicating and regulating the current of Electrical Generators, &c.*

These electro-magnets may be placed in series in a shunt, 3 4, around resistance R, in one of the main conductors (figure 6), or in multiple arc in such shunt (figure 8), or in multiple arc directly in one of the main conductors (figure 7), or in one or more multiple arc circuits, 7 8, from the main conductors 1 2 (figures 9 and 10).

The field circuit may be a single multiple arc circuit, 5 6, having a number of resistances, E, E', E<sup>2</sup>, around which are shunt circuits, *b*, *a*, to the armature levers *c*, *c*<sup>1</sup>, *c*<sup>2</sup>, and to one of the contacts, *x*, of each lever, so that the resistances will be thrown in and out in succession (figures 6, 7, and 9), or the electro-magnets, arranged in any of the ways shown, may be used to open and close circuits of a divided field (figures 8 and 10), four circuits 9 10, 9*g*, 9*h*, 9*i* being shown in these figures.

The apparatus operates in the following manner, videlicet:—

With a small number of lamps in circuit the minimum current will flow in the field circuit through all the resistances, E, E', E<sup>2</sup>, in the construction shown in figures 6, 7, and 9, and through the constantly closed field circuit 9, 10, in the construction shown in figures 8, and 10. With the arrangement shown in figures 6, 7, and 8, an increase in the number of lamps in circuit will cause a greater flow of current in the main conductors 1, 2. Hence more current will flow through the coils of magnets A, B, C, in the shunt circuit 3 4, and in one of the main conductors, and these magnets will attract their armatures in succession, which, by forming contacts at *x*, will cut resistance out of the field circuit (figures 6 and 7), or close new field circuits (figure 8), the electro-motive force of the machine being thus increased as required. For example, if the generator is designed to supply sixty lamps, the magnet A would act when twenty lamps are put on, the magnet B when forty lamps are in circuit, and the magnet C when the full number of lamps is in circuit. The reverse operation takes place when lamps are taken out of circuit. In the examples illustrated in the drawings the magnet A is represented as having acted, its armature resting against its contact at *x* and cutting out resistance E (figures 6 and 7), or closing an additional field circuit 9*g* (figure 8). If, however, the electro-motive force should be increased by an increase in the speed of the engine, and without increasing the number of lamps, the magnets A, B, C, if no other devices were used, would act and still further increase the electro-motive force, and the lamps would be raised to higher than normal incandescence. This is prevented by the employment of the magnet M (figures 6, 7, and 8), which is placed in a multiple arc circuit, *m m*, from the main conductors, and opens and closes a shunt circuit, N N, around the resistance R (figures 6 and 8), or around the electro-magnets A, B, C (figure 7). This circuit may have a resistance R' (figure 7) or *r* (figures 6 and 8). When the electro-motive force is increased by an increase in the speed of the engine the magnet M closes the shunt around the resistance R (figures 6 and 8) or the magnets A, B, C (figure 7), and weakens the magnets A, B, C, causing them to throw resistance into the field circuit or open divisions of the field circuit, thus maintaining the lamps at normal incandescence. Several of the electro-magnets M, may be employed placed in separate circuits and operating successively.

With the arrangement shown in figures 9 and 10 the magnets A, B, C are affected exactly the same as are the lamps, and regulate for variations in electro-motive force, caused either by changes in the number of lamps or in the speed of the engine. If the electro-motive force is decreased by adding lamps or by a reduction in the speed of the engine, the magnets A, B, and C will successively be weakened, and their armature levers *c*, *c*<sup>1</sup>, *c*<sup>2</sup> will be drawn by their springs *d*, *d*<sup>1</sup>, *d*<sup>2</sup> against their back contacts *x*, and cut resistance out of the field circuit (figure 9), or close additional field circuits (figure 10). If the electro-motive force is increased by taking off lamps or by an increase in the speed of the engine the magnets A, B, C will act in succession to throw resistance into the field circuit (figure 9), or open divisions of the field circuit (figure 10). In the examples illustrated in figures 9 and 10 the magnet A is assumed to have acted, breaking the shunt circuit *b a* and throwing resistance E into the field circuit (figure 9), or breaking the division 9*g* of the field circuit (figure 10). It will thus be seen from the foregoing description that the normal candle-power of the lamps will be maintained practically constant.

In lieu of employing adjustable resistances to primarily vary the current flowing through the field of force circuit, I may use a rapidly vibrating circuit controller automatically operated by the current generated, and serving to control and regulate the energy of the field magnet by rapidly and successively opening and closing a circuit, preferably the field of force circuit itself. The circuit controller is constructed to make and break circuit at a number of points simultaneously so as to reduce the spark. Figures 11 and 12 represent the most simple forms of the device.

A is the generator, 1, 2, the main conductors leading therefrom, and *a* the translating devices; 3, 4 represent the field of force circuit, adapted to be made and broken at a number of points simultaneously by levers *c* retracted by springs *b* against limiting screws *e*. The levers and limiting screws are connected to form a complete circuit when the levers rest against such screws. Pins *d* of insulating material are carried by all except the front lever, and press against the levers in front of them. This circuit controller is operated by an electro-magnet, B, placed in multiple arc circuit 5 6, with or without extra resistance. Its armature lever C is retracted by a spring D, which is adjustably connected with a standard E. This lever on its forward movement, under the attraction of the magnet, forces the levers *b* off of screws *e*, thus breaking the circuit. In order to arrest the spark at the points of the multiple circuit controller the shunt 7 8 is employed, containing a resistance which may be of wire, or may be the incandescing electric lamp F (figure 11), or a portion of the coils of the field magnet (figure 12).

The apparatus operates in the following manner, videlicet:—

When the electro-motive force is normal and the candle-power of the lamps as desired, the magnet B will vibrate the lever C with a regular rapid movement, the field circuit being open (except through the spark-arresting shunt) a certain portion of the time (for example one-half). The opening of the field circuit by cutting off the current diminishes the energy of the field magnet, which would be too great if the field circuit were kept closed constantly at the vibrating circuit controller.

A decrease in the electro-motive force, produced either by the adding of translating devices or a decrease in the speed of the engine, will tend to weaken the magnet B with greater rapidity, and the lever C will play more on its back contact *x*, changing the proportion of the make and break, and allowing the field circuit to remain closed a greater portion of the time. This will increase the energy of the field magnet and produce the normal electro-motive force in the individual translation circuits. An increase in electro-motive force will have the opposite effect.

In

*Improvements for indicating and regulating the current of Electrical Generators, &c.*

In the position of the parts illustrated in the drawing, the lever C is resting on its back contact *x*, the field of force circuit 3 4 being closed through the circuit controller. The field magnet is always energized to a definite extent by the current flowing through the spark-arresting shunt.

Figures 13, 14, and 15 represent the use of two circuit controllers operating on the relay principle.

A is the generator, 1 2 the main conductors, *a* the translating devices, and 3 4 the field of force circuit containing the multiple circuit controller. This circuit controller is shown in figures 13 and 14 as composed of spring levers *h* resting against limiting screws *i*. In figure 15 the circuit controller in the field of force circuit is composed of an arm *m* pivoted at *y* on the armature lever *c*, and kept in position by friction springs *l* pressing thereon. This pivoted lever adjusts itself to the points *n*, *o*. It is evident, however, that the form of the circuit controller is not material, since any construction can be used that breaks circuit at a number of points simultaneously.

B, C are electro-magnets placed in separate multiple arc circuits 5, 6, 7, and 8 (figures 13 and 15), or in the same multiple arc circuit 7 8 (figure 14). The armature levers *b*, *c* of these electro-magnets have adjustable retractors, *d*, *g*. Electro-magnet C works the circuit controller in the field circuit, while B operates a circuit controller opening and closing a shunt circuit *e f* around C (figures 13 and 14), or opens and closes directly the circuit of C (figure 15). 9 10 represent the spark-arresting shunt containing a resistance. A lamp, D, is shown for this purpose in figures 13 and 15, while two lamps D D are shown in figure 14.

The apparatus operates in the following manner, viz:—

The magnets B and C operate upon the relay principle, magnet C always having an excess of current required for the work when the armature lever of B is drawn to its front contact.

In figures 13 and 14 the forward movement of the armature lever of B opens the shunt *e f* around C, while in figure 15 this movement completes the circuit of C, the effect being the same in either case. The movement produced by B will be responded to by C, and the field circuit will be opened and closed in varying proportions, as described with reference to figures 11 and 12.

Figure 16 illustrates a modification in the arrangement of the spark-arresting shunt. In this figure, A is the generator; 1, 2 the main conductors; *a* translating devices; and 3 4 the field of force circuit having multiple circuit controller; C is the electro-magnet placed in multiple arc circuit 5 6, which works the circuit controller consisting of the spring levers *h*, *h*; B is the vibrating armature lever of the said electro-magnet, having adjustable retractor I; 7 8 represent the spark-arresting shunt, which in this example has a series of constant resistances; D, E, F, G, H are electro-magnets in a shunt 13 14, around a resistance in one main conductor. These electro-magnets have armature levers *c*, *d* provided with springs *y*, *y'* of different power. The attraction of lever *c* to its front contact *z* serves to cut out the resistance D, while the attraction of *d* to its front contact *z'* cuts out E. Any number of these electro-magnets, G, H, may be used as before explained.

In this modification the vibrating circuit controller operates in the same manner as that described with reference to figures 11 and 12; it is shown in the drawing, figure 16, with its spring levers *h*, *h* resting on their back contacts *i*, *i*, and closing the field of force circuit 3 4 through them. Provision is, however, made for automatically varying the resistance in the spark-arresting shunt 7 8 during the intervals when the field circuit 3 4 is closed only through such shunt, in order to produce variations in current that flows through the field circuit suited to changes in the number of lamps, motors, or other translating devices in circuit.

For instance, if the generator is designed to supply sixty lamps or their equivalent in motors or other translating devices the spark-arresting resistance will be divided into three parts, as shown, the portion F being always in circuit.

Now, if twenty or less than twenty lamps are in circuit, resistances D and E will also be in circuit, as shown in the drawing, the magnets G and H not being energized sufficiently to move their armature levers. If more than twenty lamps are placed in circuit the increased flow of current in shunt 13 14 will cause G to attract its armature lever, and the shunt around resistance D will be closed. Magnet H will not attract its armature lever, however, until more than forty lamps are in circuit, when it will close the shunt around resistance E. As lamps are removed the reverse effect is produced.

In any of the forms the electro-magnet adjusted to regulate and control the electro-motive force may be arranged to open and close the circuit of the electro-magnet that operates the circuit controller. This last electro-magnet may be placed in a shunt around resistance in one main conductor, or around the spark-arresting resistance, or the portion thereof that is always in circuit, and when the shunt circuit is complete the said electro-magnet will have a surplus of energy under all conditions, while the first electro-magnet or magnets will be placed in multiple arc from the main conductors.

Or the vibrating circuit controller for regulating the generation of current may be operated by a mechanism worked by weight, spring, or other external power, the said mechanism being controlled by the current generated preferably by means of an electro-magnet placed in multiple arc from the main conductors, and having an adjustable retractor.

In the arrangement illustrated in figures 11 to 16, the translating devices (lamps or motors), the armature of the machine, and its field of force circuit are all preferably connected in multiple arc from the same main conductors.

In lieu of the arrangements hereinbefore described for regulating the generative capacity of dynamo- or magneto-electric machines, I may accomplish the same result by providing means, whereby the current passing through more or less of the coils of the exciting or field of force magnet may be reversed. Figure 17 is a diagrammatic view of a dynamo- or magneto-electric machine embodying this arrangement; 1 2 are the main conductors leading from the machine in derived or multiple arc circuits, from which are the lamps or other translating devices *a*. From the conductors 1 2 is also taken the multiple arc circuit 3 4, including the helices A A of the field magnet, but such field circuit may be supplied from an external source of electrical energy. One helix is shown as wound in separate sections or bobbins, *b*, the ends of the wire of each section being connected with a current reverser. The arrangement of the lowest section will illustrate that of the rest. The wire ends *c*, *c'* are divided into branches *e*, *e'* and *f*, *f'*, running to separate contact

*Improvements for indicating and regulating the current of Electrical Generators, &c.*

contact plates; B is a current reversing lever, moving the pivoted arms  $h$   $h'$ , which are connected by an insulating cross-piece  $h^2$ . When levers  $h$  and  $h'$  are in contact with  $e$  and  $f'$ , as shown in the drawing, the current flows through the section or bobbin in one direction, and it flows in the opposite direction when such levers are in contact with  $f$  and  $e'$ . The machine is most powerful when the reversers are shifted to give the current direct passage through all the coils of the field-magnet, and its generative capacity can be reduced to any desired extent by reversing the current in the proper number of sections or bobbins. Although only one of the helices is shown, as wound in sections, it is obvious that both helices may be so arranged, and when the wire is wound upon the core in layers, one above another, any number of the layers (one or more) may be arranged in connection with one or more current reversers. It is evident that the form of the current reverser is not material, since any well-known or suitable construction may be used.

I claim as my invention in means for indicating and regulating the current of Electrical Generators for supplying Electric Lights and other purposes—

First—The combination with one or more electrical generators having a multiple arc field circuit and supplying lamps or other translating devices located in derived or multiple arc circuits of an alarm or indicator operated by the current generated and indicating variations of candle-power above or below, or both above and below, the desired limit, such alarm or indicator being controlled by an electro-magnet, also located in a multiple arc circuit, and the several parts of the apparatus being arranged and combined so as to operate, substantially in the manner hereinbefore described.

Second—The combination with a safety catch between the translating devices and the generator or generators of an electrically operated alarm, arranged to be sounded when the main circuit is opened by the safety catch, substantially as hereinbefore described.

Third—The double vibrating mechanism, controlled by an electro-magnet located in a derived or multiple arc circuit for throwing resistance into and out of the field circuit of a dynamo- or magneto-electric machine, or a battery or number of such machines supplying lamps or other translating devices arranged in multiple arc, substantially as hereinbefore described with reference to figure 2 of the accompanying drawings.

Fourth—The combination, with a dynamo- or magneto-electric machine supplying lamps or other translating devices located in derived or multiple arc circuits, of mechanism actuated by the current generated for adjusting the position of the commutator brushes or springs of the machine for the purpose of regulating its generative capacity, and of an electro-magnet controlling such mechanism located in a multiple arc or derived circuit, the whole being arranged and combined so as to operate, substantially in the manner hereinbefore described.

Fifth—The combination, with the generator and the groups of translating devices arranged in multiple arc, of means in connection with each group operated by the current generated, for regulating the current energizing the field magnet of the generator acting automatically upon the addition or removal of translating devices in the group, substantially as hereinbefore described.

Sixth—The combination, with the generator and translating devices in multiple arc, of a series of devices operated by the current generated and arranged to act successively as more translating devices are placed in circuit, to increase the current energizing the field magnet of the generator, substantially as hereinbefore described.

Seventh—The combination, with the features set forth in the preceding claiming clause, of a device or series of devices for compensating for an increase in the speed of the engine, substantially as hereinbefore described.

Eighth—The combination, with a dynamo- or magneto-electric machine, of a vibrating circuit controller operated or controlled by the current generated for regulating the generation of current by the machine, substantially as hereinbefore described.

Ninth—The combination, with a dynamo- or magneto-electric machine, of a vibrating circuit controller operated or controlled by the current generated, and adapted to make and break circuit at a number of points simultaneously, for regulating the generation of current by the machine, substantially as hereinbefore described.

Tenth—The combination, with a dynamo- or magneto-electric machine, of a vibrating circuit controller, for regulating the generation of current by the machine, and an electro-magnet placed in multiple arc from the main conductors leading from the machine for operating or controlling the operation of the vibrating circuit controller, substantially as hereinbefore described.

Eleventh—The combination, with a dynamo- or magneto-electric machine and a vibrating circuit controller operated or controlled by the current generated for regulating the generation of current by the machine, of a spark-arresting shunt around the said vibrating circuit controller, substantially as hereinbefore described.

Twelfth—The combination, with a dynamo- or magneto-electric machine and a vibrating circuit controller operated or controlled by the current generated for regulating the generation of current by the machine, of a shunt around the said vibrating circuit controller containing a series of constant resistances for reducing the spark, each of the said resistances being automatically thrown into or out of circuit by the removal or addition of a definite predetermined number of translating devices, substantially as hereinbefore described.

Thirteenth

---

*Improvements for indicating and regulating the current of Electrical Generators, &c.*

---

Thirteenth—The combination, with the field magnet of a dynamo- or magneto-electric machine, having its coils divided into a number of separate sections of current reversers for reversing the polarity of current in more or less of such sections, substantially as and for the purpose hereinbefore described.

In witness whereof, I, the said Thomas Alva Edison, have hereto set my hand and seal, this twenty-seventh day of December, 1882.

THOMAS ALVA EDISON,  
(By his Attorney, EDWD. WATERS).

Signed and sealed this twenty-seventh day of December, 1882, at Melbourne, Victoria, in the presence of,—

W. S. BAYSTON, Law Clerk, Melbourne.

This is the specification, marked "A," referred to in the annexed Letters of Registration granted to Thomas Alva Edison, this 5th day of March, A.D. 1883.

AUGUSTUS LOFTUS.

---

REPORT.

---

Sir,

We do ourselves the honor to report in reply to your blank-cover communication of the 30th ultimo, No. 14,163, that we are of opinion the prayer of Thomas Alva Edison for an invention entitled "Improvements in means for indicating and regulating the current of Electrical Generators for supplying Electric Lights and other purposes," may be granted in terms of his Petition, specification, drawings, and claim.

Sydney, 16 January, 1883.

We have &c.,  
E. C. CRACKNELL.  
GOTHER K. MANN.

The Under Secretary of Justice.

---

[Drawings—two sheets.]

---

No. 1207.

[Assignment of No. 1080. See Letters of Registration for 1882, page 215.]

No. 1208.

[Assignment of No. 911. See Letters of Registration for 1881, page 29.]

"B"

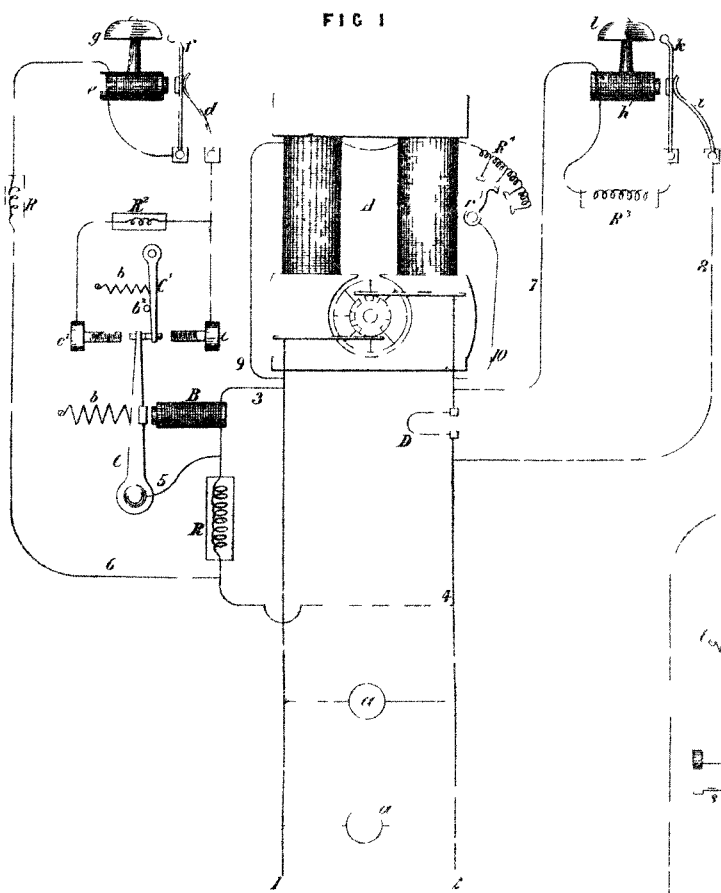


FIG 1

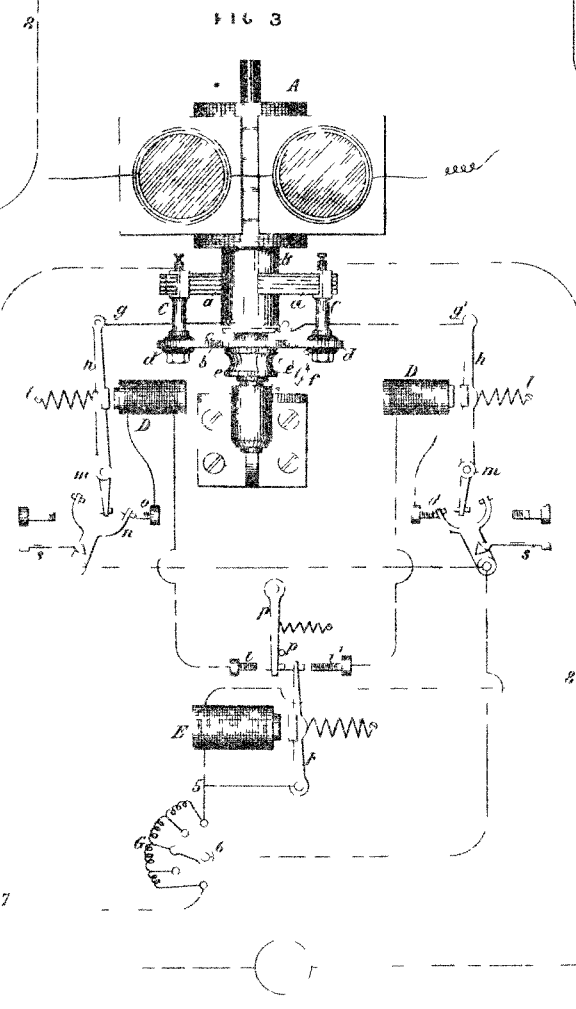


FIG 3

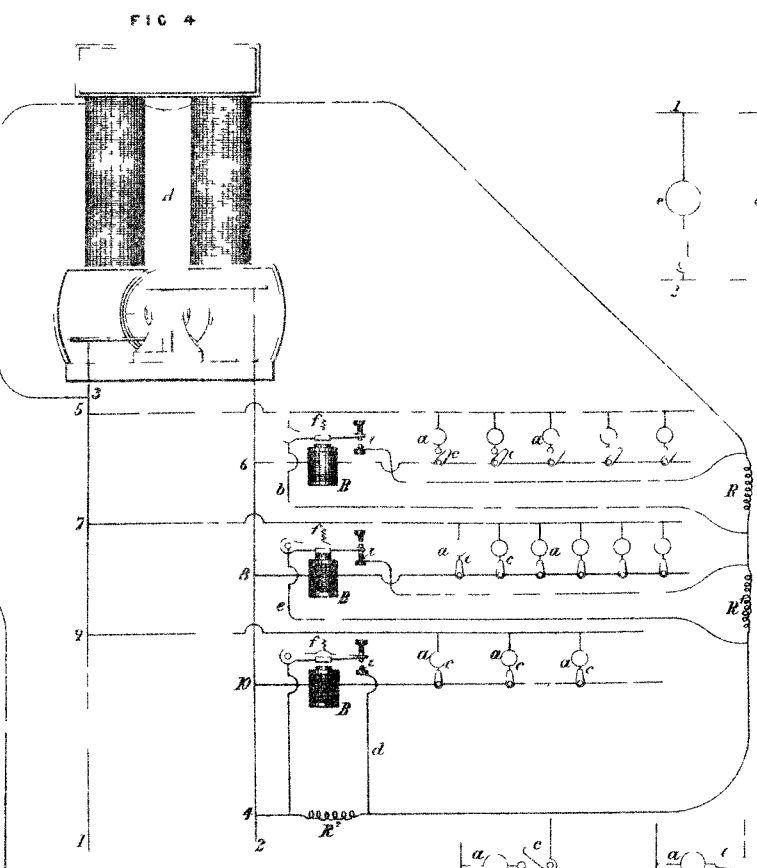


FIG 4

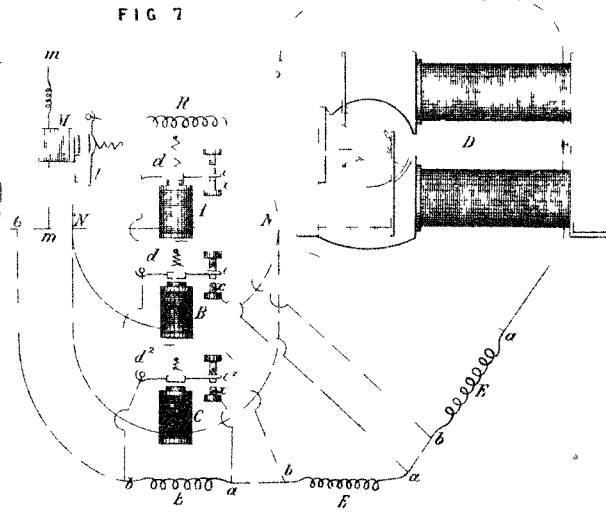


FIG 7

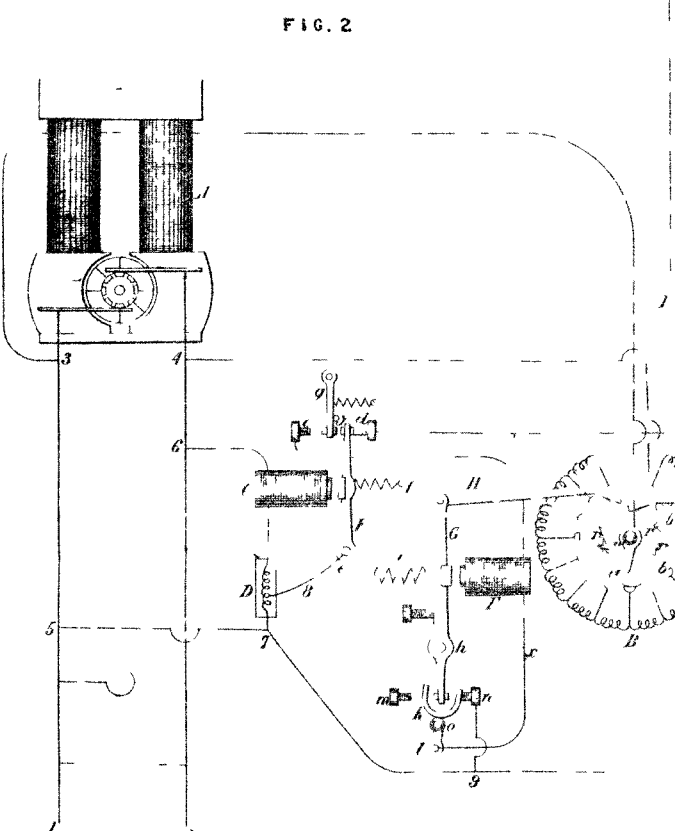


FIG 2

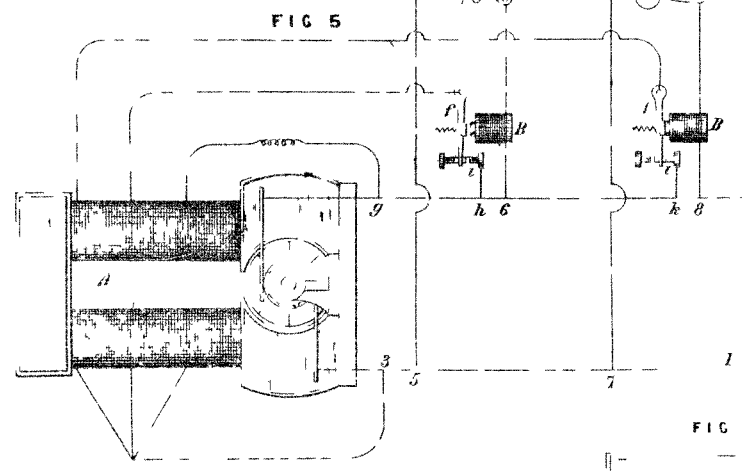


FIG 5

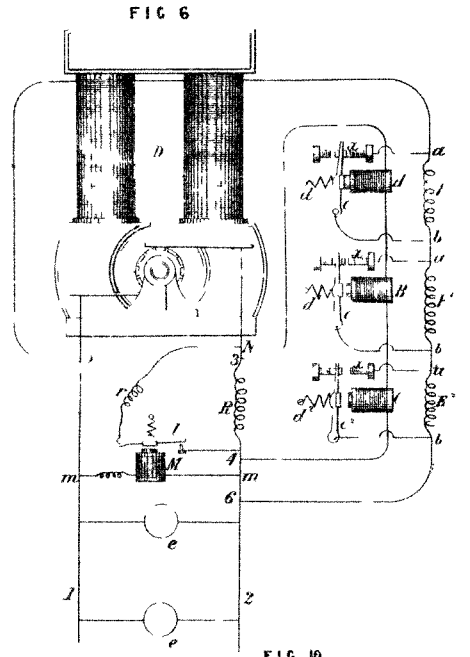


FIG 6

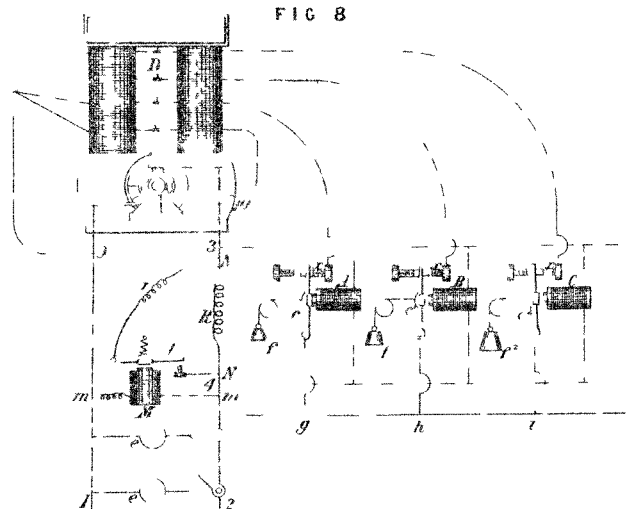


FIG 8

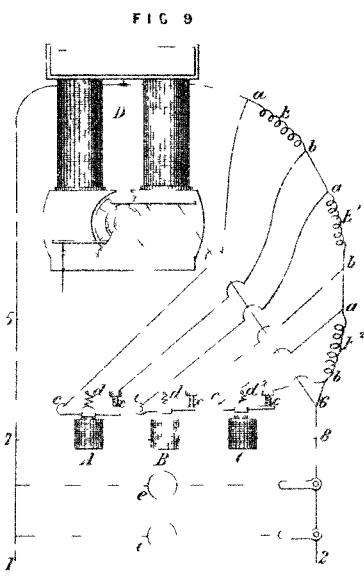


FIG 9

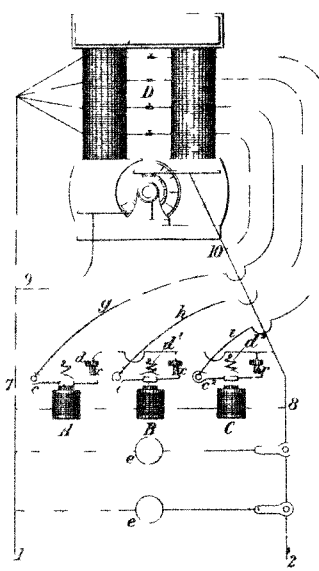


FIG 10

This is the Sheet of Drawings marked B referred to  
 in the annexed Letters of Registration granted to  
 Thomas Alva Edison this fifth day of March A D 1883  
 Augustus Voftus

PRINTED BY T. C. NEWELL, MALE, NEW YORK



C

FIG 11

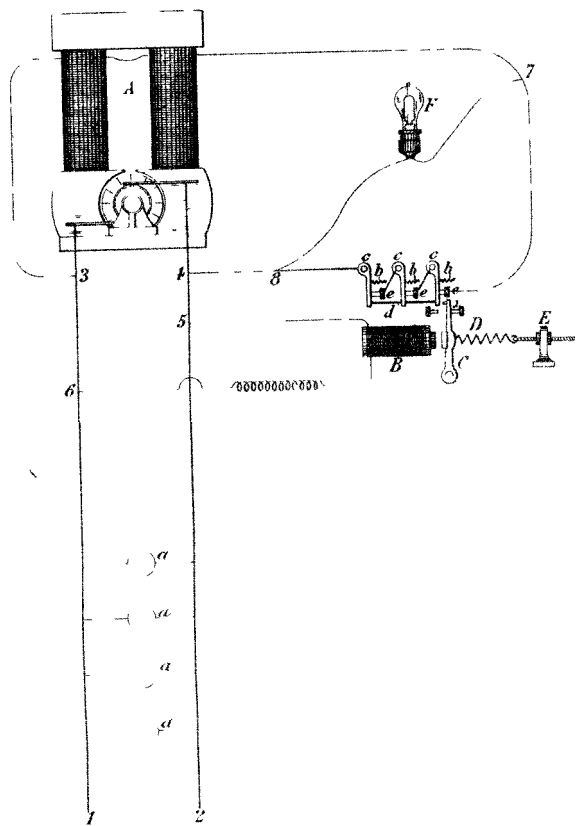


FIG 13

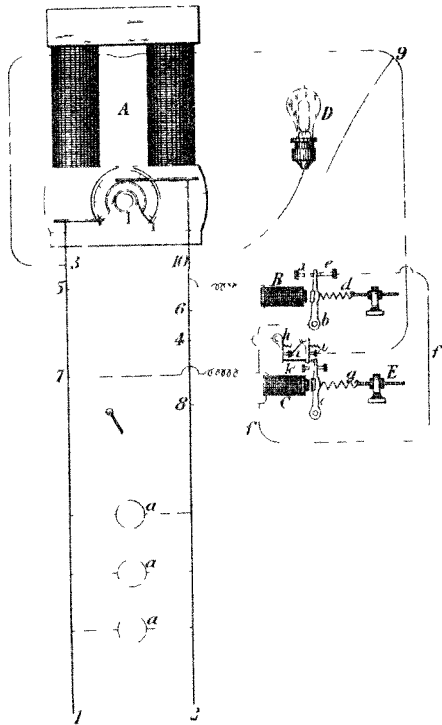


FIG 15

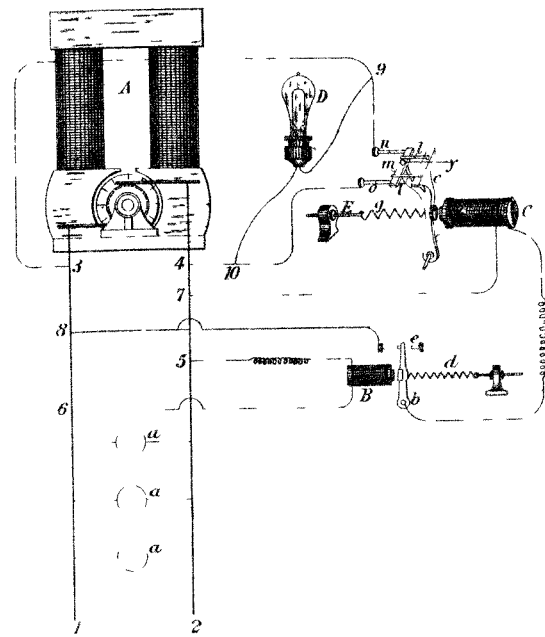


FIG 17

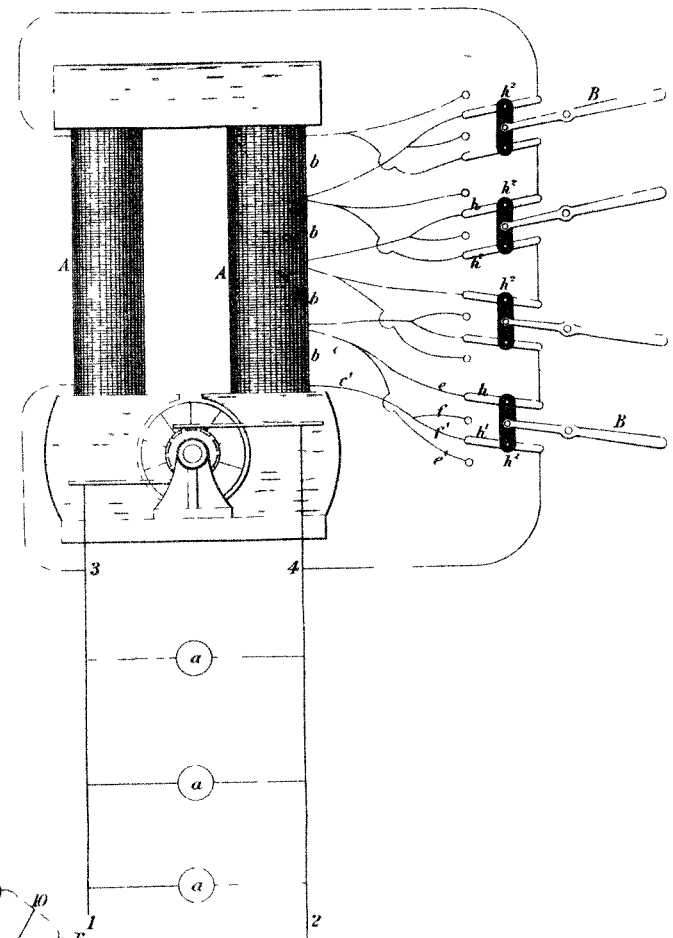


FIG 12

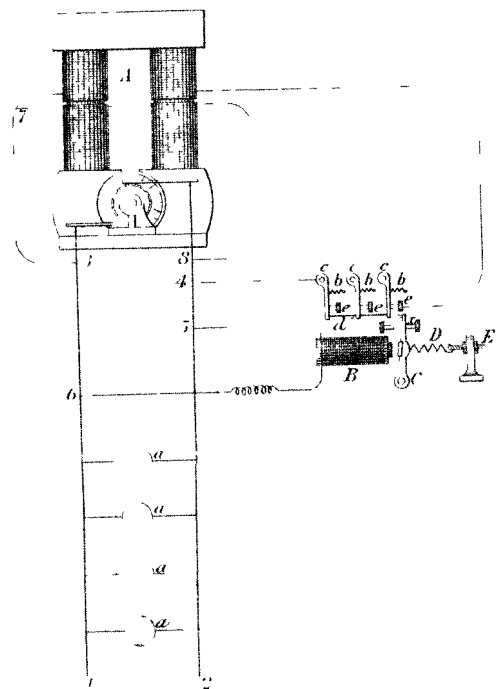


FIG 14

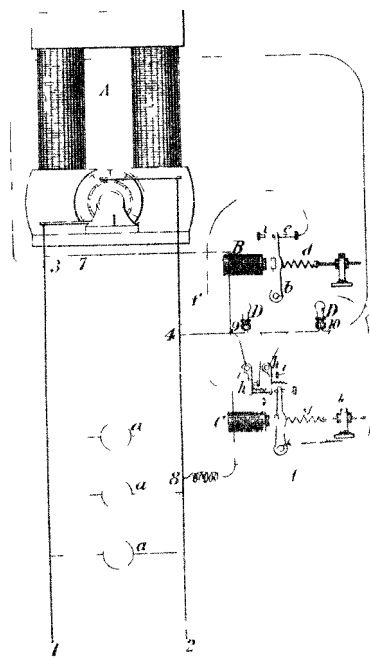
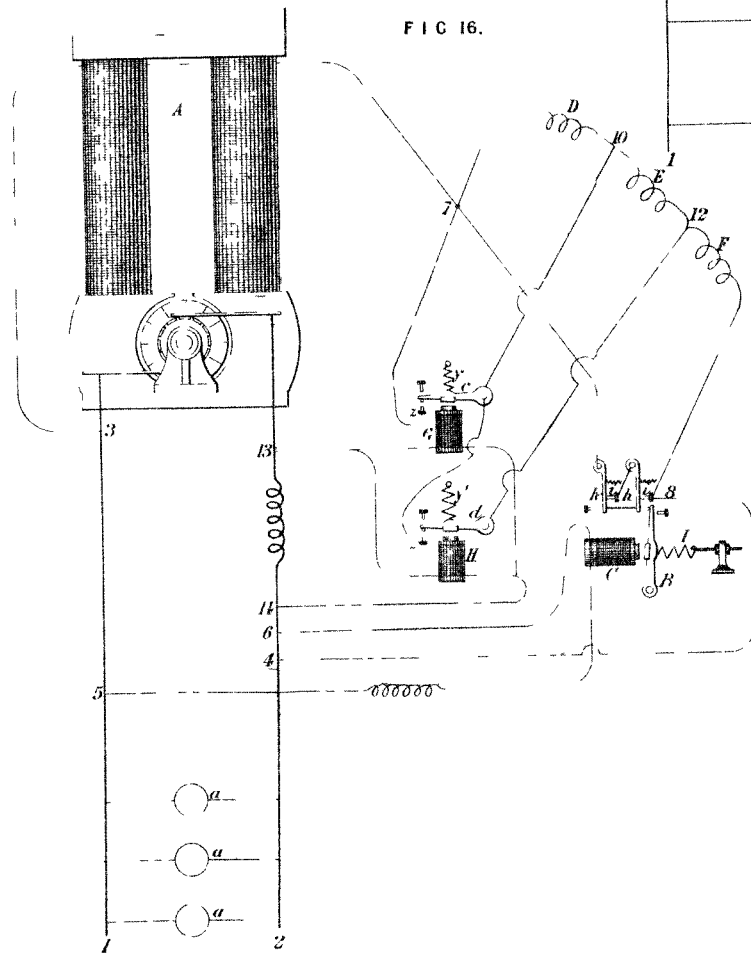


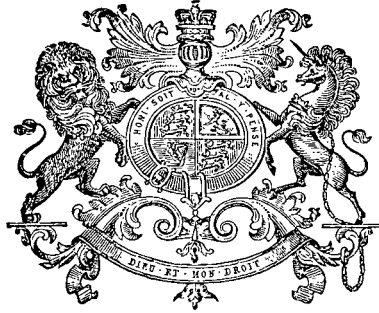
FIG 16



This is the Sheet of Drawings marked C referred to  
 in the annexed Letters of Registration granted to  
 Thomas Alva Edison this fifth day of March, A.D. 1883.  
 Augustus Kottus,

Fig 50






---

A.D. 1883, 17th March. No. 1209.

---

IMPROVEMENTS IN ELECTRIC LIGHTING.

---

LETTERS OF REGISTRATION to Edward Weston, for Improvements in Electric Lighting Apparatus, and in Apparatus for use in connection therewith.

[Registered on the 19th day of March, 1883, in pursuance of the Act 16 Vic. No. 24.]

---

BY HIS EXCELLENCY THE RIGHT HONORABLE SIR AUGUSTUS WILLIAM FREDERICK SPENCER LOFTUS (commonly called LORD AUGUSTUS LOFTUS), Knight Grand Cross of the Most Honorable Order of the Bath, a Member of Her Majesty's Most Honorable Privy Council, Governor and Commander-in-Chief of the Colony of New South Wales and its Dependencies.

TO ALL TO WHOM THESE PRESENTS SHALL COME, greeting :

WHEREAS EDWARD WESTON, of Newark, New Jersey, United States of America, hath by his Petition humbly represented to me that he is the author or designer of a certain invention or improvement in manufactures, that is to say, of an invention entitled, "Improvements in Electric Lighting Apparatus, and in Apparatus for use in connection therewith," which is more particularly described in the specification marked A, and the two sheets of drawings marked B and C respectively, which are hereunto annexed; and that he, the said Petitioner, hath deposited with the Honorable the Treasurer of the said Colony of New South Wales the sum of Twenty Pounds sterling, for defraying the expense of granting these Letters of Registration, as required by the Act of Council, sixteenth Victoria, number twenty-four; and hath humbly prayed that I would be pleased to grant Letters of Registration, whereby the exclusive enjoyment and advantage of the said invention or improvement might be secured to him for a period of fourteen years: And I, being willing to give encouragement to all inventions and improvements in the arts or manufactures which may be for the public good, and having received a report favourable to the prayer of the said Petition from competent persons appointed by me to examine and consider the matters stated therein and to report thereon for my information, am pleased, with the advice of the Executive Council, and in exercise of the power and authority given to me by the said Act of Council, to grant, and do by these Letters of Registration grant unto the said Edward Weston, his executors, administrators, and assigns, the exclusive enjoyment and advantage of the said invention or improvement, for and during the term of fourteen years from the date hereof; to have, hold, and exercise unto the said Edward Weston, his executors, administrators, and assigns, the exclusive enjoyment and advantage thereof, for and during and unto the full end and term of fourteen years from the date of these presents next and immediately ensuing, and fully to be complete and ended: Provided always, that if the said Edward Weston shall not, within three days after the granting of these Letters of Registration, register the same in the proper office in the Supreme Court, at Sydney, in the said Colony of New South Wales, then these Letters of Registration, and all advantages whatsoever hereby granted, shall cease and become void.

In witness whereof, I have hereunto set my sign manual, and have caused the present Letters of Registration to be sealed with the seal of the said Colony of New South Wales, at Government House, Sydney, in New South Wales, this seventeenth day of March, in the year of our Lord one thousand eight hundred and eight-three.

[L.S.]

AUGUSTUS LOFTUS.

*Improvements in Electric Lighting Apparatus, &c.*

A.

SPECIFICATION of EDWARD WESTON, of Newark, New Jersey, United States of America, for an invention entitled "Improvements in Electric Lighting Apparatus and in Apparatus for use in connection therewith."

THE first part of this invention relates to electric arc lamps in which are employed in conjunction with a single set of feed regulating magnets, two sets or pairs of carbon pencils or electrodes and independent feeding devices connected therewith, which devices by the consumption of the carbons are brought successively under the controlling influence of the aforesaid magnets.

In lamps constructed according to this part of my invention, the carbons or electrodes are fed and adjusted through the instrumentality of clutch mechanism, consisting essentially of a plate or bar connected at one end to a movable armature or its equivalent, and resting at the other end upon the lamp frame. The said plate or bar is perforated and surrounds the carbon carrier. When the armature is raised and the plate connected therewith is tilted a short distance it gripes the carrier, so that the position of the latter depends upon the elevation of the armature.

In the construction of my improved lamp I have taken advantage of the fact that a definite tilt or inclination must be imparted to the clamp before it gripes the carbon carrier, by allowing one of the clamps to remain in its normal position, while a block or plate is inserted between the free end of the other clamp and the lamp frame, by these means the clamp is tilted in a reverse direction, as far as practicable, without moving the carrier. Under these conditions the clamp could only raise its carrier by being tilted to a position to which the armature could bring it only by being raised beyond its normal range of motion. The armature, therefore, will not be sensibly affected by this clamp, while the other clamp will be caused to perform its normal functions.

Both carriers are in electrical contact with the frame of the lamp, to which the current is brought, so that the circuit will be between the positive and negative lamp terminals through that pair of carbons in contact or between which the arc is formed. For the purpose of regulation the carbons that are designed to be consumed last are separated by a catch which holds the upper carbon a short distance from the lower one.

To withdraw the plate from the clamp and to release the aforesaid catch and to allow the second set of carbons to ignite when the first pair has been consumed, I employ an electro-magnet in a circuit arranged to be closed by an adjustable stop on the carbon carrier of the first pair and a shifting lever of peculiar construction, the character and arrangement of which will be readily understood by reference to the accompanying drawings.

Figure 1 is a side elevation partly in section showing the working parts of my improved lamp.

Figure 2 is a side elevation partly in section at right angles to figure 1, a portion of the supporting base being omitted, and the electro-magnets shown in dotted lines.

Figure 3 is a plan partly in horizontal section of the same.

Figure 4 is a perspective view of the clutch mechanism attached.

Figure 5 is a diagram illustrating the arrangement of the circuits.

Upon a plate C are fixed the devices usually employed in my electric lamps, that is to say:—A bi-polar magnet B B is supported by a standard A and wound with two sets of coils in opposite directions, one in the main or lamp circuit and the other in a shunt about the lamp. An armature D in front of the said magnet is supported by flat springs E\* secured to a standard F\*, and a tension device is provided for regulating the armature and a dash-pot P for preventing any sudden movement or vibration of the moving parts.

This form of lamp regulator is employed in this case only in illustration of my invention, as it may be varied in a great number of ways.

To the armature D is clamped a light bar  $d^1$ , to the opposite ends of which the links  $d$  are fringed. These links connect with the ends of clamps or clamping plates or bars  $E E^1$  of ordinary construction, and serve to tilt the clamps when the armature is raised. The ends of the clamps  $E E^1$  rest upon the plate C or are provided with adjustable stops or screws,  $e e^1$  R R' are two parallel carbon carriers controlled by the above described clamps; F is an electro-magnet, the coils of which are in a normally open circuit. This magnet is arranged with its poles downward and fixed between the free ends of the clamps; H is an iron block, serving as an armature to this magnet F, and forming part of or otherwise connected with a pivoted lever L. This lever is formed with wedge-shaped enlargements,  $h h^1$ , on its ends which are forced under one or the other of the stops  $e e^1$ , as the lever is swung on its pivot, and by these means either clamp may be raised. The magnet F is wound with an insulated wire which is connected at one end to the negative clamp terminal, and at the other end to an insulated metal collar or stop V suitably secured to the top of a frame V'. On the carbon carrier R is a stop or collar W which is placed at such a point that it may come in contact with the collar V and arrest the descent of the carrier, when the carbon carried thereby has been nearly consumed.

On the carrier R' is an adjustable collar G<sup>1</sup>, with the edge of which a weighted catch G pivoted to the lamp frame is arranged to engage. The lever forming the said catch G has an arm  $g$  which extends up through the plate C and lies in the path of a projection K on the lever L. A binding screw G<sup>1</sup> properly set in an arm clamped to the plate C is employed to limit the movement of the said arm  $g$  in one direction.

The lamp being provided with carbons, the carrier R' is raised and sustained by the catch G. The lever L is shifted to bring the enlarged end  $h^1$  under the screw  $e^1$  on the clamp  $E^1$ . In this condition, the current will pass through the set of carbons, of which the upper one is connected to the carrier R, and these carbons will be consumed, the armature D having only to sustain the weight of the carrier R. When the latter has descended sufficiently to bring the stop W into contact with the collar V, a portion of the current is directed through the coils of the magnet F, the effect of which is to shift the lever L, thus permitting the clamp  $E^1$  to descend into such a position as to be affected by the movement of the armature D, and releasing the carrier R' from the catch G. At the same time the clamp E is raised by the enlargement  $h$ , so that the armature D has now the weight of the carrier R' only to sustain.

The coils of the magnet F, or the circuit in which the same are included, should be of very high resistance, so that when the second set of carbons is brought into circuit, only a very small portion of the current will flow through the said coils.

Provision

*Improvements in Electric Lighting Apparatus, &c.*

Provision may be made for breaking the circuit through the magnet F, after it has performed its functions, the lever L forming a convenient means for affecting this object in several well known ways.

The principles of construction and operation above described are applicable to various electric lamps other than that illustrated in the drawings.

The second part of my invention relates to electro-magnetic apparatus, and is designed especially for use with electric lamp regulators, or similar devices, the chief object of this part of the said invention being to produce a magnet which, while occupying a very small space, shall possess great attractive power.

This part of my invention is illustrated in figures 6 and 7 of the accompanying drawings.

Figure 6 is a central vertical section of a magnet.

Figure 7 illustrates the application of the same to a special form of electric lamp.

A is the bobbin composed of a hollow spool of metal or other material, between the flanges of which a number of convolutions of coarse copper wire D are wound. Suspended within the hollow spool is an iron core C, attached to or forming part of an iron shell B which completely encloses the top and sides of the spool or bobbin A. The action of a magnet thus constructed will be much more powerful than that of an ordinary electro-magnet, as both the core and the shell are affected by the current circulating in the coil D.

In figure 7, K represents the base of the box or case containing the regulating mechanism. B is the electro-magnet constructed as above described. F is a pivoted frame carrying a train of gear wheels 1, 2, 3, and pinions 4, 5, 6. The pinion 4 gears with a carbon rack-bar H, and the wheel 3 gears with a pinion 7, on a fan or flutter wheel L. When the magnet B is energized and the shell and core are drawn down, one of the said wheels (or pinions or generally that of the said flutter wheel) is brought into engagement with a detent. By this contrivance the rack-bar H to which the carbon is attached is raised, and the arc is formed.

The special advantage of this form of magnet is due to its reduced size and great power. Usually it is necessary to employ a V-shaped, or horse-shoe magnet with these lamps, as the attractive force produced by a single helix is not sufficient to sustain the weight of the carbon, the rack-bar, and other parts, but I have found the form of magnet above described to be amply sufficient for this purpose. Moreover it possesses the further advantage of involving the minimum of expense, and of difficulty in its manufacture, as compared with other forms of electro-magnets now employed.

It is sometimes desirable to wind the helix with two separate coils, one of coarse wire for the main or arc circuit, and the other of fine wire (as indicated at E, figure 6) for the shunt about the lamp. The object of this arrangement as will be well understood, is to effect a more delicate and accurate feed of the carbons than that obtainable by the usual method of employing the spring S, figure 7, to counteract the attraction of the main magnet. In this case the effect of the fine wire coil, would be to counteract that of the inner coil and produce a very delicate and sensitive magnet.

Having thus fully described my said invention, and the manner of performing the same, I wish it understood that I claim—

First—In an electric lamp containing two sets of carbons, the combination with the electro-magnet of independent feed mechanism or devices (one for each set of carbons), a pivoted armature lever adapted to be shifted to maintain either of the said feed devices out of operation, and an electro-magnet, independent of the feed magnets, arranged to shift the said lever for the purpose of bringing into operation the second set of carbons when the first set has been consumed, all substantially as described.

Second—In an electric lamp containing one set of feed controlling magnets, and two sets of carbons, the combination with the movable armature of two independently connected clutch devices (one for each set of carbons), a pivoted armature lever adapted to be shifted to raise the free end of either of the said clutch devices, and an independent electro-magnet for shifting the lever, all substantially as described.

Third—In an electric lamp containing two sets of carbons, and independent feed devices or sets of mechanism therefor, the combination with one of the said sets of mechanism, for keeping the same inactive and out of circuit, an electro-magnet in a normally open branch circuit, for bringing the same into action, and a stop or equivalent device on the carrier of the other set, arranged to close the branch circuit through the magnet, when the said carrier has descended a predetermined distance, all substantially as set forth.

Fourth—In an electric lamp containing two sets of carbons, as described, the combination with the clamps or clutch devices of devices for maintaining the free ends in a slightly elevated position, for the purpose of keeping them out of engagement with the carbon carriers, substantially as set forth.

Fifth—The combination with the armature D, the clamps E E', and the carbon carriers controlled thereby, of the armature lever L having the bevelled enlargements  $h h'$ , substantially as and for the purpose set forth.

Sixth—The combination with a carbon carrier R' (in a lamp containing two sets of carbons), of a pivoted hook or catch G having an arm  $g$  extending into the path of movement of the shifting mechanism, substantially as and for the purpose set forth.

Seventh—The combination with the armature D, the clamps E E' and the carbon carriers R R' of the lever L (having the bevelled enlargements  $h h'$ , and the arm K), an electro-magnet F for changing the position of the said lever, and a weighted catch G arranged to be tipped by the said arm K, all substantially as and for the purpose set forth.

Eighth—The combination with a hollow helix of insulated wire of a movable armature composed of a central core, and enclosing shell of iron, substantially as shown and described.

Ninth—The combination (in an electric lamp) with the swinging lever or frame, supporting the feed regulating mechanism, of a hollow stationary helix, composed of one or more coils of insulated wire, and a movable armature consisting of a central core, and enclosing shell of iron, all substantially as shown and described.

In

---

*Improvements in Electric Lighting Apparatus, &c.*

---

In witness whereof, I, the said Edward Weston, have hereto set my hand and seal, this sixth day of January, one thousand eight hundred and eighty-three.

EDWD. WESTON,

By his Agent EDWD. WATERS.

Witness—

U. S. BAYSTON.

—

This is the specification marked A referred to in the annexed Letters of Registration granted to Edward Weston, this 17th day of March, A.D. 1883.

AUGUSTUS LOFTUS.

---

REPORT.

---

Sir,

Sydney, 24 January, 1883.

We do ourselves the honor to report, in reply to your blank cover communication, 16th instant, No. 864, transmitting Mr. Edward Weston's application for the registration of an invention entitled "Improvements in Electric Lighting Apparatus, and in Apparatus for use in connection therewith," that we are of opinion the prayer of the Petitioner may be granted in terms of his specification, drawings, and claim.

We have, &c.,

E. C. CRACKNELL.  
GOTHER K. MANN.

The Under Secretary of Justice.

---

[Drawings—two sheets.]

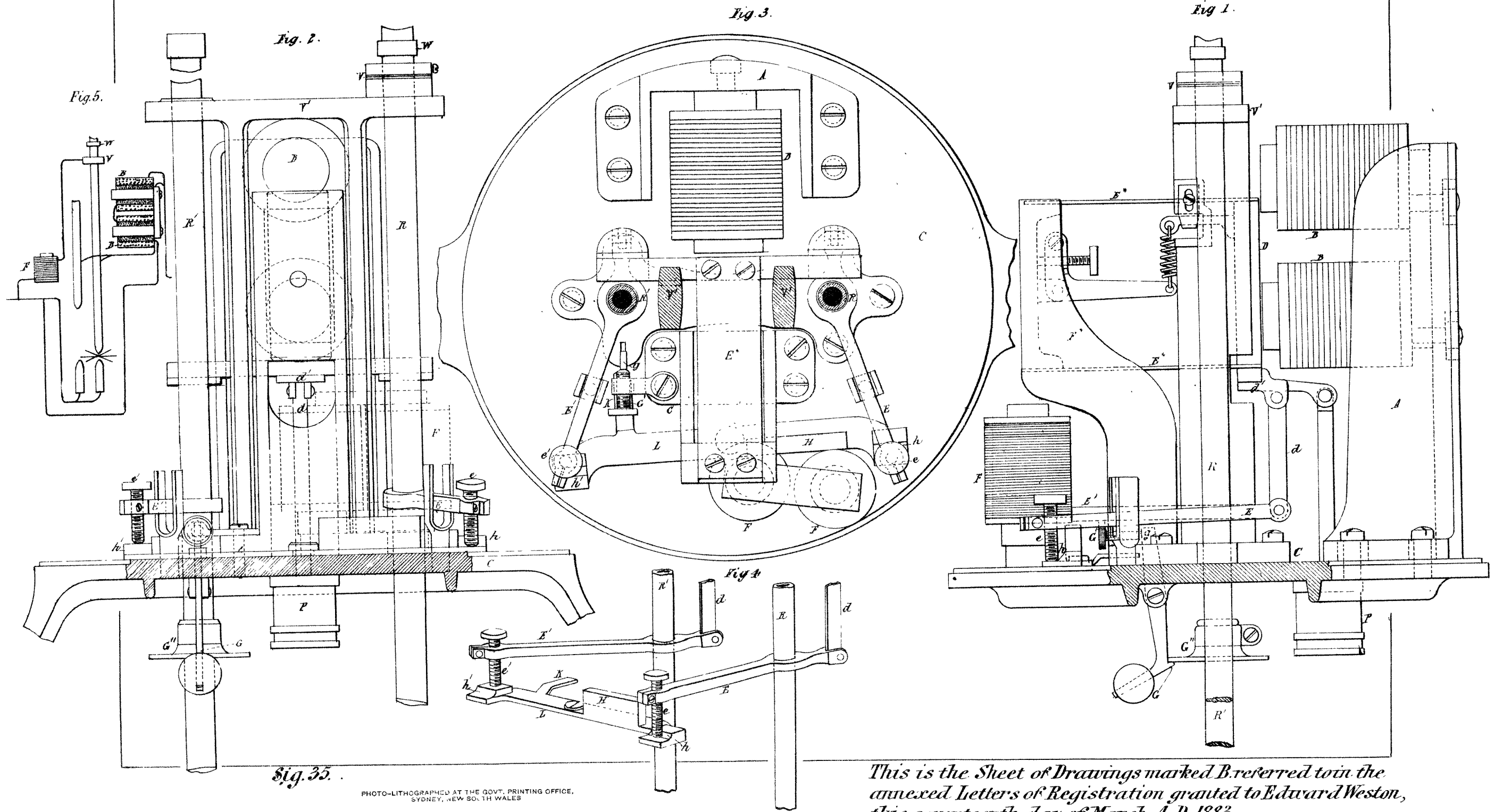


Fig. 35.

PHOTO-LITHOGRAPHED AT THE GOVT. PRINTING OFFICE, SYDNEY, NEW SOUTH WALES

This is the Sheet of Drawings marked B. referred to in the annexed Letters of Registration granted to Edward Weston, this seventeenth day of March A.D. 1883.

Augustus Loftus.

Fig. 6.

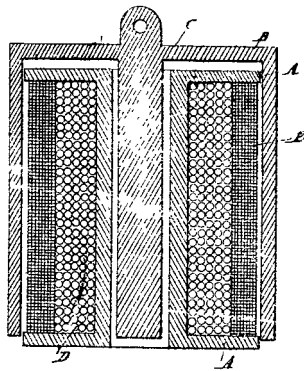
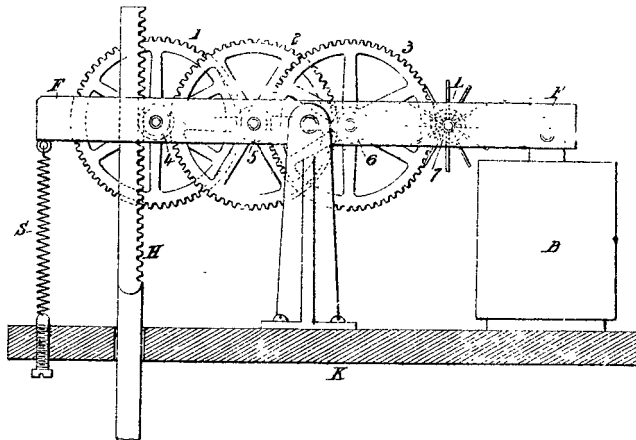


Fig. 7.



*This is the Sheet of Drawings marked C referred to in the annexed Letters of Registration granted to Edward Weston, this seventeenth day of March A. D. 1883.*

*Augustus Loftus.*



A.D. 1883, 17th March, No. 1210.

AN IMPROVED BALANCE LIFT.

LETTERS OF REGISTRATION to Edward William Cracknell, for an Improved Balance Lift.

[Registered on the 19th day of March, 1883, in pursuance of the Act 16 Vic. No. 24.]

BY HIS EXCELLENCY THE RIGHT HONORABLE SIR AUGUSTUS WILLIAM FREDERICK SPENCER LOFTUS (commonly called LORD AUGUSTUS LOFTUS), Knight Grand Cross of the Most Honorable Order of the Bath, a Member of Her Majesty's Most Honorable Privy Council, Governor and Commander-in-Chief of the Colony of New South Wales and its Dependencies.

TO ALL TO WHOM THESE PRESENTS SHALL COME, greeting :

WHEREAS EDWARD WILLIAM CRACKNELL, of 257, George-street, Sydney, in the Colony of New South Wales, consulting engineer and architect, hath by his Petition humbly represented to me that he is the author or designer of a certain invention or improvement in manufactures, that is to say, of an invention entitled "An Improved Balance Lift," which is more particularly described in the specification and the sheet of drawings which are hereunto annexed, and that he, the said Petitioner, hath deposited with the Honorable the Treasurer of the said Colony of New South Wales the sum of Twenty Pounds sterling, for defraying the expense of granting these Letters of Registration, as required by the Act of Council, sixteenth Victoria, number twenty-four, and hath humbly prayed that I would be pleased to grant Letters of Registration, whereby the exclusive enjoyment and advantage of the said invention or improvement might be secured to him for a period of fourteen years: And I, being willing to give encouragement to all inventions and improvements in the arts or manufactures which may be for the public good, and having received a report favourable to the prayer of the said Petition, from competent persons appointed by me to examine and consider the matters stated therein and to report thereon for my information, am pleased, with the advice of the Executive Council, and in exercise of the power and authority given to me by the said Act of Council, to grant, and do by these Letters of Registration grant unto the said Edward William Cracknell, his executors, administrators, and assigns, the exclusive enjoyment and advantage of the said invention or improvement, for and during the term of fourteen years from the date hereof; to have, hold, and exercise unto the said Edward William Cracknell, his executors, administrators, and assigns, the exclusive enjoyment and advantage thereof, for and during and unto the full end and term of fourteen years from the date of these presents next and immediately ensuing, and fully to be complete and ended: Provided always, that if the said Edward William Cracknell shall not, within three days after the granting of these Letters of Registration, register the same in the proper office in the Supreme Court, at Sydney, in the said Colony of New South Wales, then these Letters of Registration, and all advantages whatsoever hereby granted, shall cease and become void.

In witness whereof, I have hereunto set my sign manual, and have caused the present Letters of Registration to be sealed with the seal of the said Colony of New South Wales, at Government House, Sydney, in New South Wales, this seventeenth day of March, in the year of our Lord one thousand eight hundred and eighty-three.

[L.S.]

AUGUSTUS LOFTUS.

*An Improved Balance Lift.*

SPECIFICATION of EDWARD WILLIAM CRACKNELL, consulting engineer and architect, of 257, George-street, Sydney, for an invention entitled an "Improved Balance Lift."

It consists of a double-ended ram, working in cylinders, which may be attached to or connected with the cylinder of any direct acting hydraulic lift as hereinafter described.

Figure 1 shows a section through the balance.

Figure 2 shows its application to a direct acting lift.

A is a direct acting lift ram, which works in the cylinder B, and lifts the cage C. D is a double-ended ram, which is sufficiently loaded so as to nearly balance the ram A and cage, the ram A having a sufficient weight unbalanced to ensure its descent.

This ram D works in the cylinders H and I, the cylinder I being of sufficient size to allow the end of the ram D to have a displacement equal to that of the lift ram A.

When water, gas, air, or vapour is admitted into the upper cylinder H by means of a valve, cock, or other suitable device, it forces the ram D into the lower cylinder I, which being connected with the lift cylinder B, forces the water or other fluid through a suitable aperture of pipe into the cylinder B, and thus causes the ram A and cage C to ascend; but as the ram A ascends it increases in weight, so the balance ram D must have a corresponding increase in weight while descending, in order to preserve an equal balance.

I obtain this increase by providing the ram D with a tank J, connected with the supply tank K by the pipe L, being brought through a gland in the tank J, and fixed so that the tank can work up and down.

As the ram D descends the water from the supply tank K runs through the pipe L into the tank J, and thus increases the load on the ram D as the ram A increases in weight.

When the ram A descends the ram D ascends, raising the tank J, thus causing the water to run back through the pipe L into the tank K, thus decreasing the load on the balance ram as the ram A decreases in weight by descending into the water in the cylinder B.

This lift can be worked with any available pressure by proportioning the upper balance cylinder to suit the pressure, and where a sufficient low pressure is used, the tanks J and K may be dispensed with, for the increasing weight of water in the upper cylinder H will be sufficient to balance the increasing weight of ram. Sufficient weight of water can be pumped direct to the ram A if required to make up any loss which might arise through defective packing.

I claim the following advantages possessed by this machine—

First—There is no danger of the ram breaking, it being always in compression, there being no balance chains above the cage to drag it upwards, in the event of the ram being detached.

Second—An equal and perfect balance can be obtained during the ascent and descent of the cage, and consequently a uniform speed is secured by means of the tanks on the ram D.

Third—It can be cast or bolted to the upper part of any direct acting lift cylinder.

Fourth—There are no working parts liable to get out of order, and no pistons to keep tight, or cylinders to bore, as the cylinders H and I only require to be bored at the ends of the gland or leathers.

Fifth—The increased speed or power can be given to existing direct acting lifts by using the balance with an upper cylinder of the requisite size.

Sixth—That no overhead gear is required, such as balance weights, pulleys, &c.

Seventh—That the balance ram D always keeps a solid column of water under the cage, and thus prevents the cage from falling after being temporarily suspended by a box or other obstruction, being placed across the hatchway.

Given under my hand and seal, this thirteenth day of January, one thousand eight hundred and eighty-three.

E. W. CRACKNELL.

This is the specification referred to in the annexed Letters of Registration granted to Edward William Cracknell, this 17th day of March, A.D. 1883.

AUGUSTUS LOFTUS.

### REPORT.

Sir,

Sydney, 23 January, 1883.

We do ourselves the honor to report, in reply to your blank cover communication of the 16th instant, No. 929, transmitting Mr. Edward William Cracknell's Petition for the registration of an invention entitled "Improved Balance Lift," that we are of opinion the prayer of Mr. Cracknell's petition may be granted in terms of specifications, drawings, and claim.

We have, &c.,

E. O. MORIARTY.  
GOTHER K. MANN.

The Under Secretary of Justice.



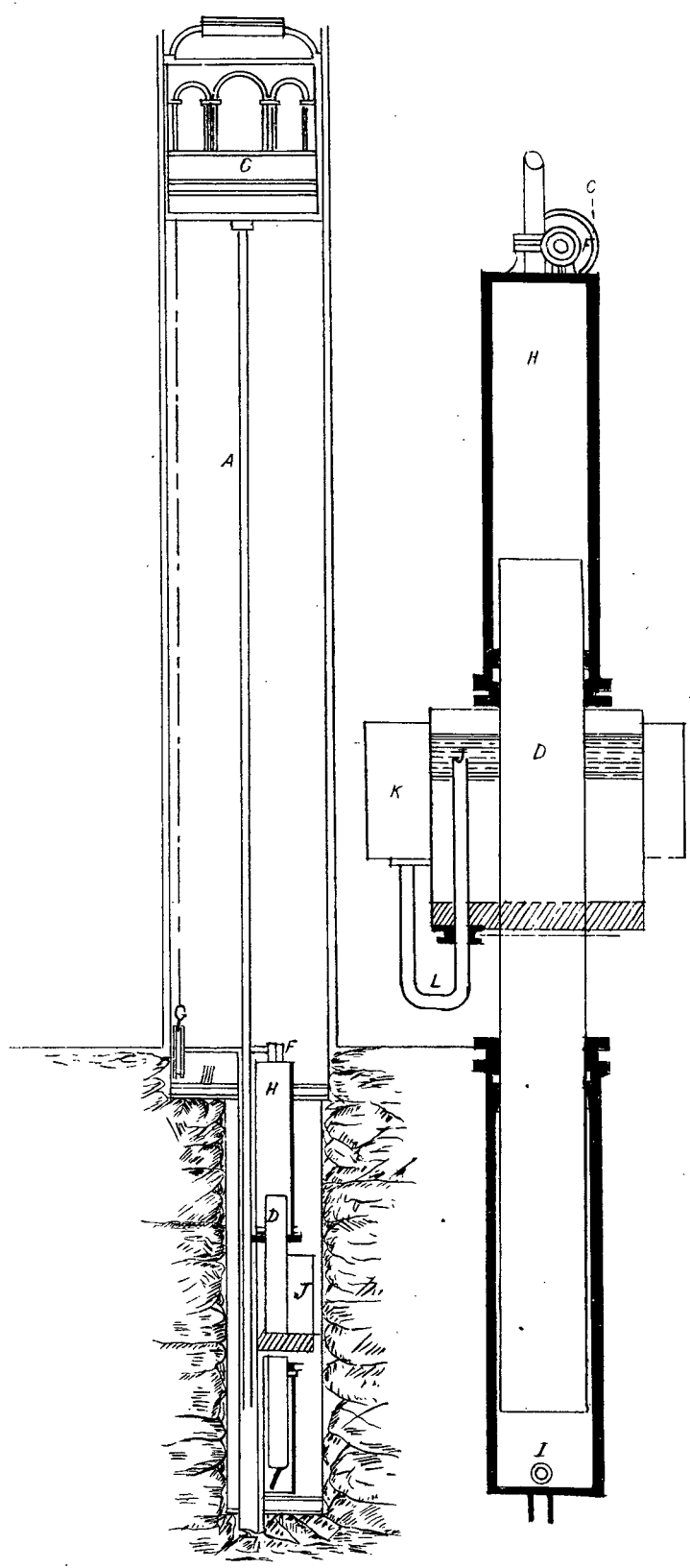


Fig 2.

Fig.1.

*This is the Sheet of Drawings referred to in the annexed  
 Letters of Registration granted to Edward William  
 Cracknell, this 17<sup>th</sup> day of March, A.D. 1883.*

*Augustus Loftus.*



A.D. 1883, 17th *March*. No. 1211.

IMPROVEMENTS IN THE MANUFACTURE OF CARBON CONDUCTORS FOR  
ELECTRIC LAMPS.

LETTERS OF REGISTRATION to Hiram Stevens Maxim, for Improvements in the manufacture of Carbon Conductors for Electric Lamps, and in apparatus to be employed in such manufacture.

[Registered on the 19th day of March, 1883, in pursuance of the Act 16 Vic. No. 24.]

BY HIS EXCELLENCY THE RIGHT HONORABLE SIR AUGUSTUS WILLIAM FREDERICK SPENCER LOFTUS (commonly called LORD AUGUSTUS LOFTUS), Knight Grand Cross of the Most Honorable Order of the Bath, a Member of Her Majesty's Most Honorable Privy Council, Governor and Commander-in-Chief of the Colony of New South Wales and its Dependencies.

TO ALL TO WHOM THESE PRESENTS SHALL COME, greeting :

WHEREAS HIRAM STEVENS MAXIM, of Brooklyn, New York, United States of America, hath by his Petition humbly represented to me that he is the author or designer of a certain invention or improvement in manufactures, that is to say, of an invention entitled "Improvements in the manufacture of Carbon Conductors for Electric Lamps, and in apparatus to be employed in such manufacture," which is more particularly described in the specification and the sheet of drawings which are hereunto annexed ; and that he, the said Petitioner, hath deposited with the Honorable the Treasurer of the said Colony of New South Wales the sum of Twenty Pounds sterling, for defraying the expense of granting these Letters of Registration, as required by the Act of Council, sixteenth Victoria, number twenty-four ; and hath humbly prayed that I would be pleased to grant Letters of Registration, whereby the exclusive enjoyment and advantage of the said invention or improvement might be secured to him for a period of fourteen years : And I, being willing to give encouragement to all inventions and improvements in the arts or manufactures which may be for the public good, and having received a report favourable to the prayer of the said Petition, from competent persons appointed by me to examine and consider the matters stated therein and to report thereon for my information, am pleased, with the advice of the Executive Council, and in exercise of the power and authority given to me by the said Act of Council, to grant, and do by these Letters of Registration grant unto the said Hiram Stevens Maxim, his executors, administrators, and assigns, the exclusive enjoyment and advantage of the said invention or improvement, for and during the term of fourteen years from the date hereof ; to have, hold, and exercise unto the said Hiram Stevens Maxim, his executors, administrators, and assigns, the exclusive enjoyment and advantage thereof, for and during and unto the full end and term of fourteen years from the date of these presents next and immediately ensuing, and fully to be complete and ended. Provided always, that if the said Hiram Stevens Maxim shall not, within three days after the granting of these Letters of Registration, register the same in the proper office in the Supreme Court, at Sydney, in the said Colony of New South Wales, then these Letters of Registration, and all advantages whatsoever hereby granted, shall cease and become void.

In witness whereof, I have hereunto set my sign manual, and have caused the present Letters of Registration to be sealed with the seal of the said Colony of New South Wales, at Government House, Sydney, in New South Wales, this seventeenth day of March, in the year of our Lord one thousand eight hundred and eighty-three.

[L.S.]

AUGUSTUS LOFTUS.

*Improvements in the Manufacture of Carbon Conductors for Electric Lamps.*

SPECIFICATION of HIRAM STEVENS MAXIM, of Brooklyn, New York, United States of America, for an invention entitled "Improvements in the manufacture of Carbon Conductors for Electric Lamps, and in apparatus to be employed in such manufacture."

My invention relates to the manufacture of carbon conductors for use in incandescent electric lamps. Such conductors, as is well known, have a slender thread-like illuminating portion, with enlarged clamping ends. As it is desirable that these strips should all be of exactly the same quality and size, it has been usual to cut them by a die from sheets of paper or wood, in the form of flat strips, with widened ends, but when plastic carbonisable compounds are used for making the carbon, it is very difficult to obtain any considerable number of strips of even approximately the same size and resistance, by any of the methods of manufacture heretofore employed, such as moulding, and then carbonising, or by cutting out the strips from a hard mass of carbon.

My invention is designed to avoid the difficulties heretofore existing, in the manufacture of carbon conducting strips of an equal width or diameter from plastic compositions, and consists in a continuous process of, and devices for forming the said conducting strips.

The said invention is illustrated in the accompanying drawing in which

Figure 1 is an elevation partly in section of my said apparatus.

Figure 2 is a plan drawn to an enlarged scale of an attachment therefor; and

Figure 3 is an edge view of the same.

Figures 4 and 5 are illustrations of the carbon conducting strips.

A is a strong frame; B is an ordinary hydraulic or steam press cylinder, containing the piston E, and provided with ports or conduits C and D, for introducing steam above and below the piston; G is a cylinder similar in many respects to that of an ordinary pipe press, or the modified form thereof, commonly used in the formation of carbon pencils for electric arc lamps; F is a plunger connected with the piston E, and arranged to work in the cylinder G; H is a pipe or other passage for the introduction into the cylinder G of the plastic material to be used for making the carbons; K is a nozzle through which the material is forced. Attached to this nozzle is a die, with an adjustable aperture; a convenient form of this device is represented in figures 2 and 3 and consists of a head R, with a screw-threaded portion S, and a flange O. L is a ring fitting around the head R, and milled or provided with handles, by which it may be readily turned from side to side; MM are crank levers pivoted to pins *n*, in the stationary head R; NN are plates capable of a radial movement in the dove-tailed grooves in the head R. The levers M are slotted at both ends, and by their slots they are connected with the ring L, and plates NN respectively by means of pins *l* *l'*. The aperture of the die or nozzle, is directly in the centre of the head R, so that by sliding the plates N, in or out, the extent of this aperture is varied. The movement or adjustment of the said plates is effected by turning, to one side or the other, the ring L, and thereby, through the levers M, shifting the said plates.

The operation of the above described devices is as follows, that is to say:—A quantity of plastic carbonisable compound of the desired kind is introduced under the plunger in the cylinder G, through the pipe H, this compound being kept hot and soft by a steam jacket or by a burner P, or by other convenient means. The ring L is then turned so that the die or nozzle is opened to its full extent, and steam is introduced above the piston E, and the pressure on this piston causes the plunger F to force the compound in the cylinder G through the said die. When the desired amount of this compound has been forced out, the ring L is turned to reduce the size of the aperture in the die to its smallest area, so that the mixture now issues in a fine thread. When the length of this is equal to that desired for the carbon strip, or somewhat greater, the ring L is again turned to enlarge the said aperture. By these means a continuous strip of the compound is produced, having enlargements at regular intervals as illustrated in figure 5. As this strip issues from the press, it is cut into lengths, the points of division being midway between the said enlargements. Each section will thus be composed of a slender strip with enlarged ends, and these sections may then be bent into any desired shape, packed in sand, or in a muffle, and baked, as in the usual process of manufacturing carbon electrodes.

The materials ordinarily employed for making the carbons, are finely powdered graphite, or retort carbon, and a cohesive substance, such as copal or coal-tar. The ingredients and their proportions, however, may be greatly varied. Moreover, the means described for enlarging or contracting the die may be varied. For example, instead of turning the ring L by hand, automatic devices may be employed to regulate the size of the said die, but, in the construction and application of such devices, care must be taken that the changes in size of the apertures shall be sufficiently slow to form a gradual taper from the enlarged to the contracted portions of the conducting strips.

It will be seen that by the above process homogeneous and efficient conductors may be rapidly produced at a slight cost, and the die which forms a part of this invention may be readily applied or adapted to the carbon presses now in use.

Having thus fully described my said invention and the manner of performing the same, I wish it understood that I claim—

First—The strips for the manufacture of carbon conductors composed by a plastic carbonisable material and formed with alternately enlarged and slender sections as set forth.

Second—The combination of a carbon press-cylinder, a nozzle, or die, and means for varying the aperture of the said die, whereby a continuous strip of plastic material of varying cross section, may be expelled from the press, substantially as set forth, and for the purpose specified.

Third—The combination with the above described carbon press-cylinder, of a die composed of a centrally perforated stationary block and adjustable plates, or slides, arranged to vary the aperture through which the material is expelled, substantially as set forth, and for the purpose specified.

In witness whereof, I, the said Hiram Stevens Maxim, have hereto set my hand and seal, this sixth day of January, 1883.

Witness—  
U. S. BAYSTON.

HIRAM STEVENS MAXIM,  
(By his Agent, EDWD. WATERS.)

This

---

*Improvements in the Manufacture of Carbon Conductors for Electric Lamps.*

---

This is the specification referred to in the annexed Letters of Registration granted to Hiram Stevens Maxim, this seventeenth day of March, A.D. 1883.

AUGUSTUS LOFTUS.

---

REPORT.

---

Sir,

Sydney, 22 January, 1883.

We do ourselves the honor to report, in reply to your blank cover communication of the 16th instant, No. 866, that we are of opinion the prayer of Mr. Hiram Stevens Maxim's petition for the registration of an invention entitled "Improvements in the manufacture of Carbon Conductors for Electric Lamps, and in apparatus to be employed in such manufacture," may be granted in terms of his specification, drawings, and claim.

We have, &c.,

E. C. CRACKNELL.  
GOTHER K. MANN.

The Under Secretary of Justice.

---

[Drawings—one sheet.]

Fig. 5



Fig. 4



Fig. 2

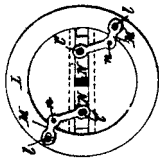


Fig. 3

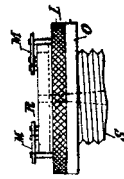
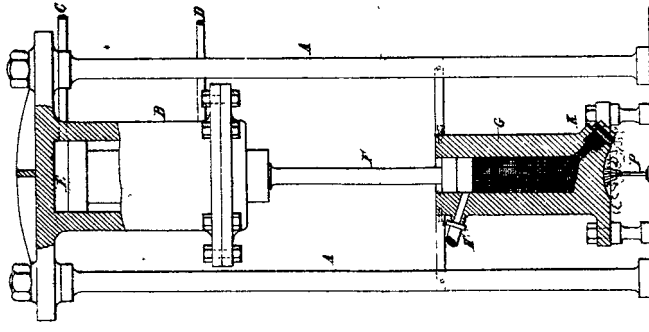


Fig. 1



*This is the Sheet of Drawings referred to in the annexed Letters of Registration granted to Hiram Stevens Maxim, this seventeenth day of March A. D. 1883.*

*Augustus Loftus.*



A.D. 1883, 17th March. No. 1212.

IMPROVEMENTS IN DYNAMO-ELECTRIC MACHINES.

LETTERS OF REGISTRATION to Edward Weston, for Improvements in  
Dynamo-Electric Machines.

[Registered on the 19th day of March, 1883, in pursuance of the Act 16 Vic. No. 24.]

BY HIS EXCELLENCY THE RIGHT HONORABLE SIR AUGUSTUS WILLIAM FREDERICK SPENCER LOFTUS (commonly called LORD AUGUSTUS LOFTUS), Knight Grand Cross of the Most Honorable Order of the Bath, a Member of Her Majesty's Most Honorable Privy Council, Governor and Commander-in-Chief of the Colony of New South Wales and its Dependencies.

TO ALL TO WHOM THESE PRESENTS SHALL COME, greeting :

WHEREAS EDWARD WESTON, of Newark, New Jersey, United States of America, hath by his Petition humbly represented to me that he is the author or designer of a certain invention or improvement in manufactures, that is to say, of an invention entitled "Improvements in Dynamo-Electric Machines," which is more particularly described in the specification marked "A" and the two sheets of drawings marked "B" and "C" respectively which are hereunto annexed; and that he, the said Petitioner, hath deposited with the Honorable the Treasurer of the said Colony of New South Wales the sum of Twenty Pounds sterling, for defraying the expense of granting these Letters of Registration, as required by the Act of Council, sixteenth Victoria, number twenty-four; and hath humbly prayed that I would be pleased to grant Letters of Registration, whereby the exclusive enjoyment and advantage of the said invention or improvement might be secured to him for a period of fourteen years: And I, being willing to give encouragement to all inventions and improvements in the arts or manufactures which may be for the public good, and having received a report favourable to the prayer of the said Petition, from competent persons appointed by me to examine and consider the matters stated therein and to report thereon for my information, am pleased, with the advice of the Executive Council, and in exercise of the power and authority given to me by the said Act of Council, to grant, and do by these Letters of Registration grant unto the said Edward Weston, his executors, administrators, and assigns, the exclusive enjoyment and advantage of the said invention or improvement, for and during the term of fourteen years from the date hereof; to have, hold, and exercise unto the said Edward Weston, his executors, administrators, and assigns, the exclusive enjoyment and advantage thereof, for and during and unto the full end and term of fourteen years from the date of these presents next and immediately ensuing, and fully to be complete and ended: Provided always, that if the said Edward Weston shall not, within three days after the granting of these Letters of Registration, register the same in the proper office in the Supreme Court, at Sydney, in the said Colony of New South Wales, then these Letters of Registration, and all advantages whatsoever hereby granted, shall cease and become void.

In witness whereof, I have hereunto set my sign manual, and have caused the present Letters of Registration to be sealed with the seal of the said Colony of New South Wales, at Government House, Sydney, in New South Wales, this seventeenth day of March, in the year of our Lord one thousand eight hundred and eighty-three.

[L.S.]

AUGUSTUS LOFTUS.

*Improvements in Dynamo-Electric Machines.*

"A."

SPECIFICATION of EDWARD WESTON, of Newark, New Jersey, United States of America, for an invention entitled "Improvements in Dynamo-Electric Machines."

ONE part of my invention relates to that class of electrical generators which have an armature wound with a number of coils, the ends of which are united to form an endless wire, and from which loops are taken off at the junctions of the originally separate sections of wire on the said armature, and united to the separate insulated segments of the commutator as in such machines heretofore constructed by me.

Great difficulty is experienced in these machines to avoid the short circuiting of the adjacent commutator strips and the consequent destruction of the insulation of the coils included in the circuit between the adjacent segments. This difficulty arises notwithstanding the fact that all of the strips on one side of a line bisecting the commutator diametrically are of opposite polarity only to those on the other side of such line, for there is a difference of potential between any two adjacent strips on either side of this line, and a consequent tendency for a current to pass from one strip to the adjacent strip having a lower potential, thus forming a branch or derived circuit through which will flow a portion of the current that should pass to the main circuit. The liability to thus short circuiting and injuring (by the effects of heat) the coils included in the circuit between any two given adjacent commutator segments is reduced by increasing the number of sections of wire on the armature, and correspondingly increasing the number of commutator segments. In this manner it is possible to so far increase the number of sections as to avoid the flow of a current of such strength as to heat any section to a degree sufficiently to destroy the insulating material. This increase of the number of sections is, however, in practice both expensive and inconvenient, and does not obviate the loss of useful effect due to the cutting out of that portion of the otherwise effective wire included between the two adjacent strips which have been short circuited.

The first part of my invention is designed to overcome these difficulties and to render the machines constructed substantially as above described, more reliable, efficient, and manageable than heretofore.

This part of my invention consists in winding the armature with two or more independent endless wires, and so connecting them by loops to the commutator segments as to avoid having any two adjacent strips of the commutator connected to loops from adjacent coils of the same wire on the armature.

In practice two wires for the armature will generally be found sufficient to avoid short circuiting the coils. In this case the armature may be wound in sections as heretofore, but in connecting them it is necessary to connect alternate sections instead of adjacent sections, and to lead the loops or ends so formed to alternate strips of the commutator. When this is done with the first series of alternate coils the second or intermediate series may be connected in the same manner to the remaining commutator segments.

In the accompanying drawings I have illustrated in figures 1, 2, and 3 the manner in which this part of my invention is carried into practice.

Figure 1 represents in perspective the end of a cylindrical armature with its commutator attached, showing the method of winding and the connections as above specified.

Figure 2 is an end view of a circular or ring armature embodying the above specified manner of winding according to my invention.

Figure 3 is a diagrammatic illustration of the winding.

It is well known that cylindrical and ring armatures as at present employed are wound with a number of independent coils or bobbins. In former patents granted to me I have constructed an armature in which these coils are connected end to end to form a single continuous wire, the connections in this case being made by the loops or joined ends passing to the commutator segments. An armature of substantially this construction is illustrated in the above-described figures of the drawings. A A are the sections of the armature, B C are the loops, D D are upright arms connected with the commutator segments, E E are the said segments.

In figure 1, A A represent the sections of a cylindrical armature. In these sections are wound the wire coils shown in white and shaded or black lines, the direction of winding and method of taking off the loops, B C, being similar to that heretofore employed by me in the construction of electric generators.

The arms, D, of the commutator segments, E, are arranged to receive at their ends the loops or ends taken from the armature coils. As shown in the drawings, the loops shown in black are connected with alternate uprights and commutator segments, while the other loops, viz., those shown in white, are connected in a similar manner to the intervening segments. It will be obvious that in this machine the brushes as they are left by one pair of segments of the commutator will bear upon another pair of segments with which there is no tendency to short circuit. The same results are obtained with a ring armature, as shown in figures 2 and 3. In this armature the loops or ends, B C, are taken from the wires, where they are brought over from one coil to the next, to form two continuous conductors.

It will be observed that in this armature, as in that shown in figure 1, the wires shown black and forming the loops from one conductor are connected to alternate strips, while the wires shown white forming the loops from the other conductor are attached to the intervening segments. In figure 3 the conductors are indicated, the one by an unbroken line, and the other by a dotted line, C B being the points of their attachment.

It will be seen that in an armature embodying this mode of winding the coils and connecting them to the commutator strips or segments, should any two adjacent strips of the commutator be accidentally connected, for instance, by particles of metal from the brushes bridging the space between the separate strips, no injury can result to the machine, nor will there be any loss of its useful effect. In order to short circuit any section of the said coils it would be necessary to connect alternate strips; this connection could only occur in practice by bridging over two of the insulating spaces, and so connecting three of the commutator strips, and its occurrence is almost an impossibility in the machine constructed as shown, and it is obvious that winding on an increased number of coils will still further reduce the liability of the machine to injury or loss of energy.

*Improvements in Dynamo-Electric Machines.*

I have now described this part of my invention, as embodied in the most practical and effective form of which I am at present aware. As above stated, my method of winding may be varied by winding each coil in independent sections, in the several recesses or groves, instead of having the wires side by side throughout their whole length as shown. In either case, however, the result will be practically or substantially the same.

Another part of my invention embraces further improvements in winding and connecting to the commutator the armature coils of dynamo-electric machines whose armature has a cylindrical core, so mounted as to be capable of revolution between the polar faces of a system of magnets.

This part of the said invention comprises—

First—A system of winding the armatures of machines which are more especially designed for furnishing currents of high electro-motive force; and

Second—A system of winding the same or similar armatures for the production of currents of low electro-motive force, but great quantity.

I have heretofore constructed machines in which the armatures are successively normal with two systems of coils one overlying the other, each system being wound in diametrically separate divisions, and each division or coil being connected to the next adjoining division by a loop, by which connection is made with one of the commutator segments.

In another type of machine designed and built by me this method of winding is embodied, but each system of coils is wound upon itself so that the two systems lie alongside each other in the divisions of the armature and equi-distant from the centre of the same. By these means the two coils of each armature division are practically of the same length, and consequently oppose severally the same degree of resistance to the passage of the induced currents.

This part of my invention is designed to render still more perfect these systems of winding by economizing time and labour and producing a more serviceable armature than has heretofore been practicable, and it consists mainly in alternately superposing the several divisions of the two systems of coils, so that the distinguishing characteristics of both the above-described methods are in a measure combined.

This part of my invention is illustrated in figures 4 and 5 of the drawings,—

Figure 4 being a perspective view of the end of an armature with the commutator and connections; and

Figure 5 a tranverse section, drawn to an enlarged scale, of the armature-cylinder, illustrating the disposition of the coils.

The armature is by preference composed of a number of plates or discs of magnetic metal strung on a shaft and held at short distances apart by collars of insulating material of considerably less diameter than the discs. When thus built up the cylinder is provided with longitudinal grooves or recesses in which the coils are to be wound.

In any two diametrically opposite recesses of the armature, as  $AA^1$ , an insulated wire of the desired size is wound until one-fourth of the said recesses is filled with a coil,  $a$ . The two ends of the wire are brought out and temporarily secured. The armature is then turned half round and the coil,  $b$ , is wound upon the first coil,  $a$ , with the same number of layers. A loop,  $b^1$ , is then formed in the usual manner, and the winding is continued alongside of the coil  $a$  until the coil  $c$  is formed. The wire is then cut off, forming a free end, which is temporarily secured. The armature is again turned half back, and the coils  $d e$  are wound in a precisely similar manner, and this method of construction is continued until all the recesses are filled, and each recess has four divisions or sections of the two systems of coils, the said sections being alternately superposed in regular order around the armature. After completing the winding the free ends of the wire are joined, as shown in figure 5, thus forming a practically continuous conductor, and by means of the loops thus formed and those originally existing connection is made with the commutator segments.

By this arrangement the two systems of coils are very nearly of equal length and equal resistance, and their mean distances from the centre of revolution are the same.

I prefer usually to so wind the two systems (which are shown respectively in black and white) that each recess will contain four divisions, as above stated, of the coil. I may, however, vary this number; for instance, each recess may contain two divisions, or more than four divisions.

The size and character of the conductors employed and the uses for which the machine is intended will determine the number of layers in each coil or section of coil, but in general practice I prefer to use this method of winding in machines intended for supplying arc lights or for other purposes for which a current of high electro-motive force is necessary.

When currents of great quantity are to be generated I adopt the method of winding illustrated in figures 6, 7, and 8, which represent a modification of this part of my invention.

Figure 6 is a longitudinal section of an armature with its appurtenances.

Figure 7 is a diagrammatic illustration of the method of winding heretofore employed.

Figure 8 a similar diagram illustrating my improvement in this method of winding.

If upon the surface of a cylindrical armature, or in the grooves cut thereon, a continuous conductor is wound with one turn in each groove, and a loop is formed at the points where the conductor passes from one groove to the next groove, as above explained, one-half as many loops will be formed as there are sections of wire around the armature.

If then the same conductor is again wound about the cylinder in the same manner as before, or if another conductor is wound either simultaneously with the first or afterwards, there will or may be formed a complete circle of loops around the armature, there being as many loops as there are sections or divisions of the armature coils. Let these loops be then connected in order to the segments of a commutator, and the whole properly mounted in a magnetic field; then all the sections on one side of the line bisecting the commutator through the neutral points will be of opposite polarity to those on the other side of such line, so that if collecting brushes be applied to the segments, at or near the points of maximum intensity, the result will be a machine having an electro-motive force which is the aggregate electro-motive force of all the sections of the coil on the armature.

In order therefore to render these machines capable of producing currents of minimum intensity and great quantity, and at the same time secure the other advantages accruing from the above-described method of construction, I take off loops from the several sections of the conductor at two points instead of at one point. I employ for this purpose two commutators and two sets of collecting brushes.

The



*Improvements in Dynamo-Electric Machines.*

The loops must be taken off from the sections at such points as will ensure an equal division of the current between them. For this purpose I form each coil or section of the armature conductor with an odd number of turns, and take off the loops or connections at points diagonally opposite with respect to the armature upon which they are wound.

This mode of construction may be understood by reference to figures 7 and 8. In figure 7 a section of a continuously wound coil is shown, the loops *a* being taken only at the junction of each coil with the next coil.

This coil, as above-stated is wound continuously about the armature and upon itself until a complete circle of loops is formed.

In figure 8 the same system of winding is adopted, but two loops, *b c*, are taken off at the junctions between the several coils and also from the middle of each coil. Loops thus formed are in the same coil always of opposite polarity.

When heavy wires are used they may be cut wherever it is desired to form a loop to avoid bending, and, instead of winding the coils back on themselves, as in other arrangements, they may be formed successively and separately alongside of each other.

In figure 6 the core is shown composed of the perforated plates, *A*, fixed on a shaft, *B*, and separated from each other by the thin discs, *C*, of insulating material. Upon the cylindrical surface of this core, or in grooves cut for their reception, the coils *DD* are wound, the connections from each being made as above described by means of the loops or united ends *b c* to arms *E*, forming parts of the commutator segments.

From this machine two separate currents may be taken and applied to different purposes; or the two sets of brushes may be connected to give a single current, the brushes being joined either in multiple arc or in series.

Having thus fully described my said invention, and the manner of performing the same, I wish it understood that I claim—

First—In or for a magneto- or dynamo-electric machine, an armature wound with two or more systems of independent continuous conductors the adjacent sections of which are connected to alternate segments of the commutator, substantially as and for the purpose set forth.

Second—In or for a magneto- or dynamo-electric machine, a cylindrical or annular armature core having grooves or recesses for the reception of the coils or bobbins, and two or more independent continuous conductors wound therein in combination with a commutator, to whose segments the said coils or bobbins are alternately connected, substantially as and for the purpose set forth.

Third—An armature wound with two systems of coils in diametrically separate divisions, the divisions of one system being alternately under and over those of the other system, and the said divisions being looped together and connected to the commutator, substantially in the manner and for the purpose set forth.

Fourth—An armature containing recesses or grooves wound with two systems of coils in diametrically separate divisions, each recess containing four of such divisions, the divisions of one system being alternately under and over the divisions of the other system, and all being looped together and connected to commutator segments, substantially as and for the purpose set forth.

Fifth—A cylindrical armature wound with a double system of continuous coils in separate divisions in combination with two independent commutators connected respectively with loops taken from diagonally opposite portions of the said divisions, substantially as and for the purpose set forth.

Sixth—An armature wound with a double system of continuous coils in separate divisions in combination with two independent commutators connected respectively with loops taken from the junctions of the several divisions of the coils, and from the middle of each of said divisions, substantially as and for the purpose set forth.

In witness whereof, I, the said Edward Weston, have hereto set my hand and seal, this sixth day of January, 1883.

Witness—  
U. S. BAYSTON.

EDWD. WESTON,  
By his Agent,  
EDWD. WATERS.

This is the specification marked "A" referred to in the annexed Letters of Registration granted to Edward Weston, this seventeenth day of March, A.D. 1883.

AUGUSTUS LOFTUS.

---

*Improvements in Dynamo-Electric Machines.*

---

## REPORT.

Sir,

Sydney, 24 January, 1883.

We do ourselves the honor to report, in reply to your blank cover communication, 16th instant, No. 865, transmitting Mr. Edward Weston's petition for the registration of an invention entitled "Improvements in Dynamo-Electric Machines," that we are of opinion the prayer of the petition may be granted in terms of Mr. Weston's specification, drawing, and claim.

We have, &c.,  
E. C. CRACKNELL.  
GOTHER K. MANN.

The Under Secretary of Justice.

---

[Drawings—two sheets.]

---

## No. 1213.

[Assignment of No. 652. See Letters of Registration for 1878, page 1.]

---

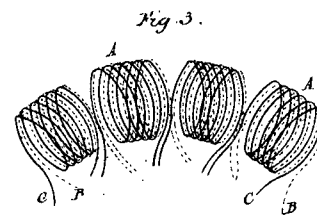
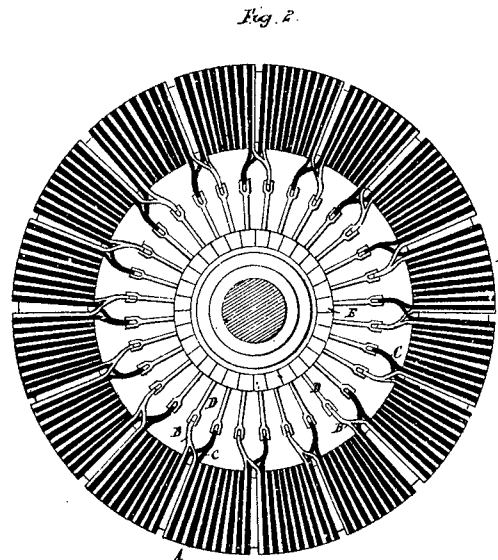
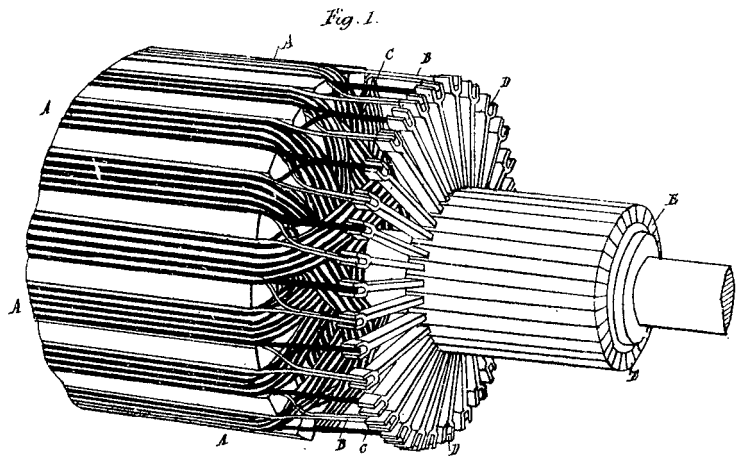
## No. 1214.

[Assignment of No. 652. See Letters of Registration for 1878, page 1.]

---

## No. 1215.

[Assignment of No. 652. See Letters of Registration for 1878, page 1.]



*This is the Sheet of Drawings marked B. referred to in the annexed Letters of Registration granted to Edward Weston, this 17<sup>th</sup> day of March A. D. 1883*

*Augustus Loftus.*

Fig. 4.

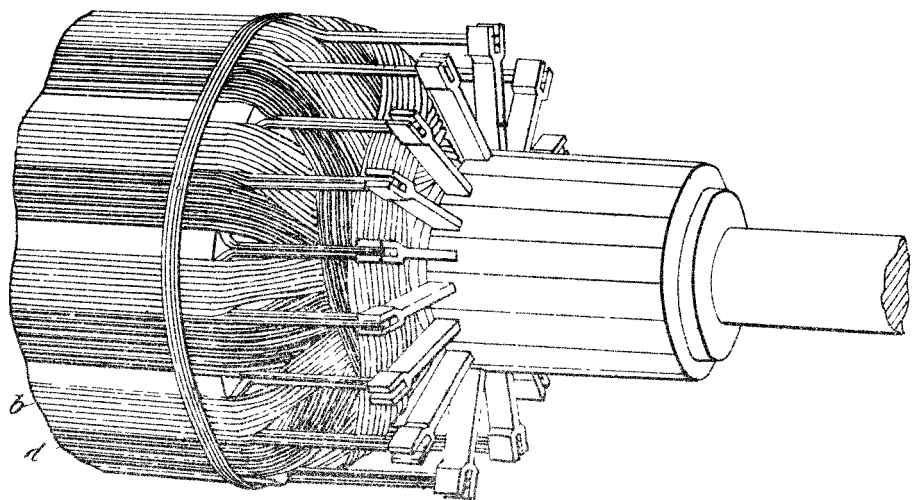


Fig. 5.

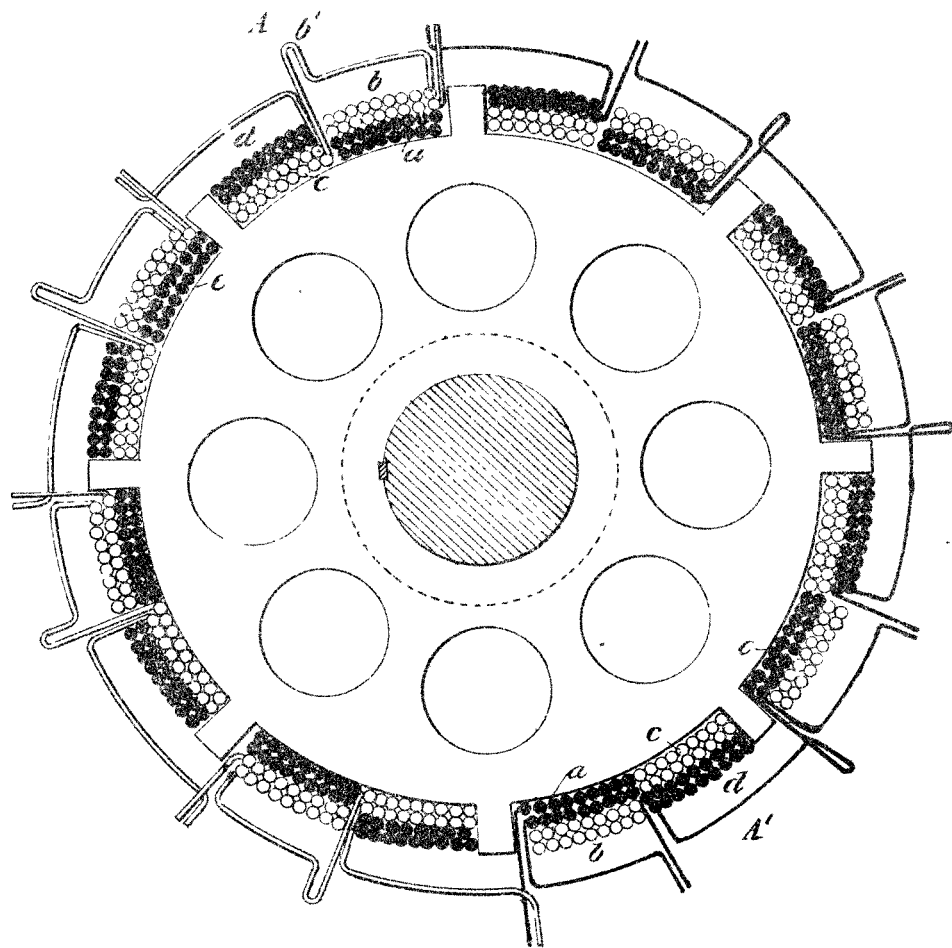


Fig. 6.

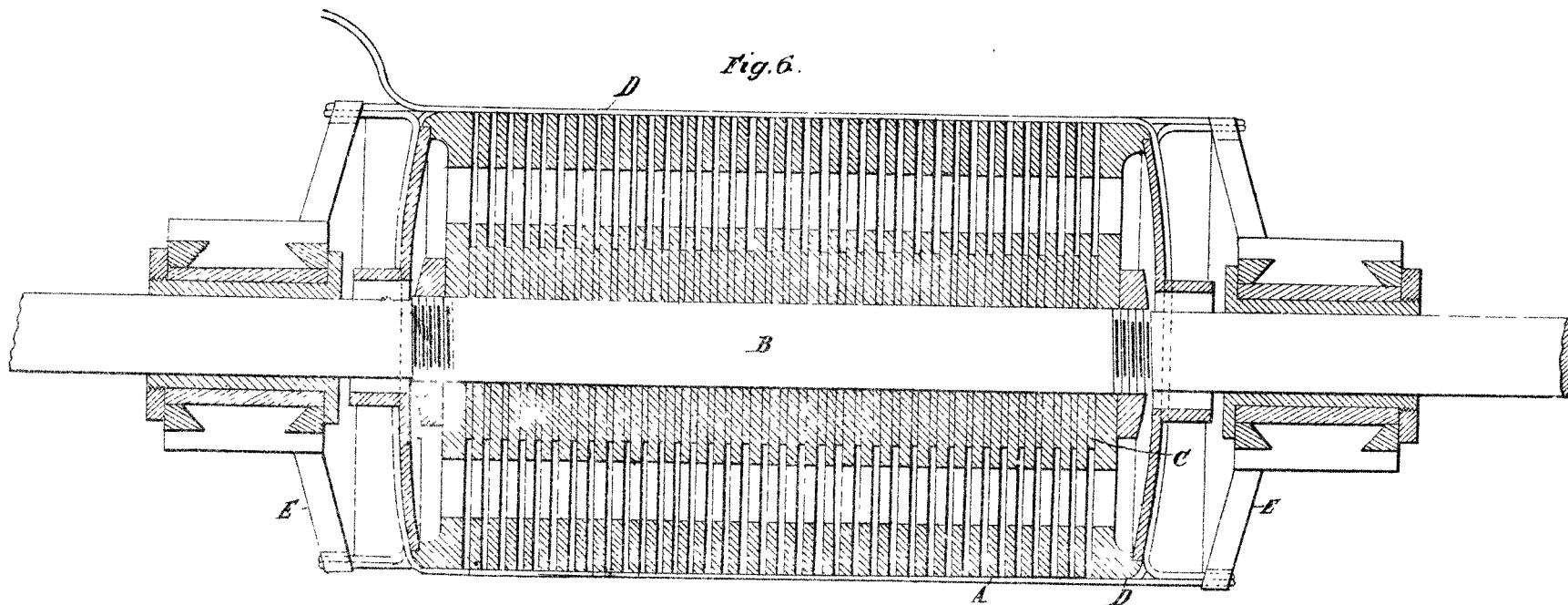


Fig. 7.

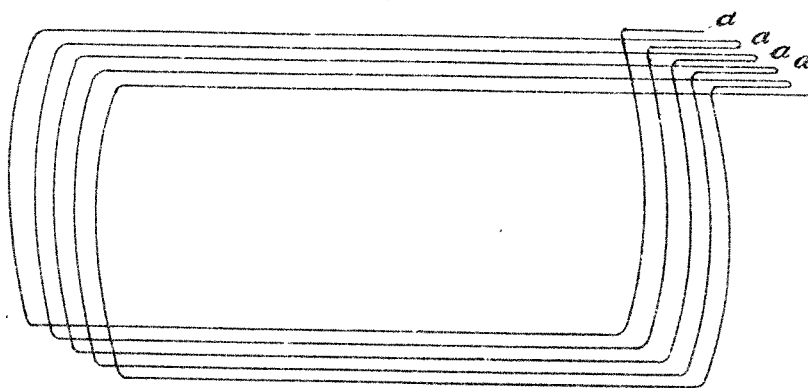
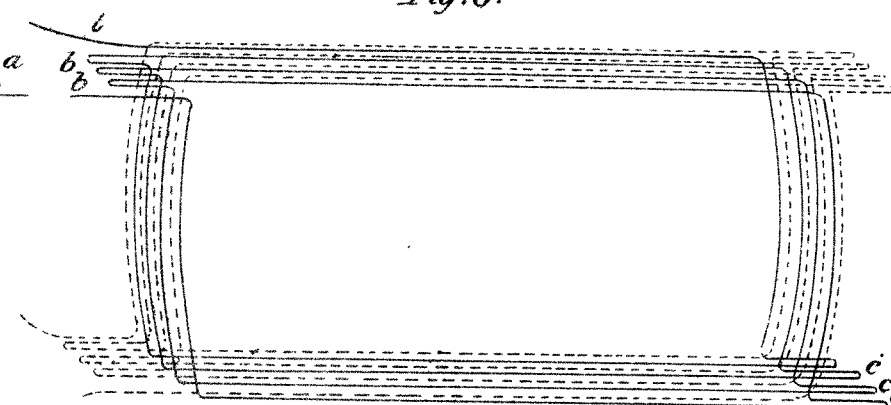


Fig. 8.



*This is the Sheet of Drawings marked C. referred to in the annexed Letters of Registration granted to Edward Weston, this 17<sup>th</sup> day of March A. D. 1883*

*Augustus Loftus.*



A.D. 1883, 9th April. No. 1216.

**IMPROVEMENTS IN MACHINERY FOR EXTRACTING ORES AND METALS FROM MINERALS AND OTHER METALLIFEROUS MATERIALS AFTER BEING GROUND OR CRUSHED.**

LETTERS OF REGISTRATION to Carl Wagemann, for an invention entitled "Improvements in Machinery for extracting Ores and Metals from Minerals and other metalliferous materials after being ground or crushed."

[Registered on the 10th day of April, 1883, in pursuance of Act 16 Vic. No. 24.]

BY HIS EXCELLENCY THE RIGHT HONORABLE SIR AUGUSTUS WILLIAM FREDERICK SPENCER LOFTUS (commonly called LORD AUGUSTUS LOFTUS), Knight Grand Cross of the Most Honorable Order of the Bath, a Member of Her Majesty's Most Honorable Privy Council, Governor and Commander-in-Chief of the Colony of New South Wales and its Dependencies.

TO ALL TO WHOM THESE PRESENTS SHALL COME, greeting :

WHEREAS CARL WAGEMANN, of No. 40, Elizabeth-street, Melbourne, in the Colony of Victoria, civil engineer, hath by his Petition humbly represented to me that he is the author or designer of a certain invention or improvement in manufactures, that is to say, of an invention entitled "Improvements in Machinery for extracting ores and metals from minerals and other metalliferous materials after being ground or crushed," which is more particularly described in the specification and the sheet of drawings which are hereunto annexed, and that he, the said Petitioner, hath deposited with the Honorable the Treasurer of the said Colony of New South Wales the sum of Twenty Pounds sterling for defraying the expense of granting these Letters of Registration, as required by the Act of Council, sixteenth Victoria, number twenty-four; and hath humbly prayed that I would be pleased to grant Letters of Registration, whereby the exclusive enjoyment and advantage of the said invention or improvement might be secured to him for a period of fourteen years: And I, being willing to give encouragement to all inventions or improvements in the arts or manufactures which may be for the public good, and having received a report favourable to the prayer of the said Petition, from competent persons appointed by me to examine and consider the matters stated therein and to report thereon for my information, am pleased, with the advice of the Executive Council, and in exercise of the power and authority given to me by the said Act of Council, to grant, and do by these Letters of Registration grant unto the said Carl Wagemann, his executors, administrators, and assigns, the exclusive enjoyment and advantage of the said invention or improvement for and during the term of fourteen years from the date hereof; to have, hold, and exercise unto the said Carl Wagemann, his executors, administrators, and assigns, the exclusive enjoyment and advantage thereof, for and during and unto the full end and term of fourteen years from the date of these presents next and immediately ensuing, and fully to be complete and ended: Provided always, that if the said Carl Wagemann shall not, within three days after the granting of these Letters of Registration, register the same in the proper office in the Supreme Court, at Sydney, in the said Colony of New South Wales, then these Letters of Registration, and all advantages whatsoever hereby granted, shall cease and become void.

In witness whereof, I have hereunto set my sign manual, and have caused the present Letters of Registration to be sealed with the seal of the said Colony of New South Wales, at Government House, Sydney, in New South Wales, this ninth day of April, in the year of our Lord, one thousand eight hundred and eighty-three.

[I.S.]

AUGUSTUS LOFTUS.

*Improvements in Machinery for Extracting Ores and Metals from Minerals, &c.*

SPECIFICATION of CARL WAGEMANN, of 40, Elizabeth-street, Melbourne, in the Colony of Victoria, civil engineer, for an invention entitled "Improvements in Machinery for extracting Ores and Metals from Minerals and other metalliferous material after being ground or crushed."

THIS invention consists of a series of machines to be used consecutively in the extraction of ores and metals from minerals and other metalliferous material after being ground or crushed, but each of which machines may be used by itself for the special purpose for which it is designed, or in conjunction with other contrivances having a similar object to those of the other machines in my series.

Those which form my series may be referred to as an automatic stream classifier, a circular jigger, and a circular conical separating table.

Stones containing ores in grains too small to be extracted from the crushed stuff by aid of sieves are to be stamped or ground to powder sufficiently fine to detach the ore from the gangue, and are, after being ground, usually treated on round buddles, rotary tables, or shaking tables, &c. All these appliances act by reason of the difference in the specific gravity of the ores and the gangue, the powdered stuff passes through a current of water, the stream of which is sufficient to carry the gangue, but not the ore which deposits. It is evident that the quantity of motive power transmitted from the current to a particle of stuff depends on the size of the latter, the larger grain offering a larger surface to the pushing action of the current, and it is also evident that a current of a certain power is able to carry a small piece of ore as well as a larger piece of light gangue, notwithstanding the greater specific gravity of the former. Till now there was no means to separate from a muddy pulp, too slimy to be treated on sieves, the coarser grains from the slime, and therefore rotary or shaking tables and similar apparatus were working with a heavy loss of slimy ore (if adjusted for coarse grains), or they delivered a not sufficiently cleaned ore (if adjusted for saving slimy ores).

Besides this insufficiency the best appliances for separating fine grained and slimy ores from the powdered gangue, viz., rotary tables suffer under the necessity of reducing the working surface to about 9 feet diameter, and thus offering a very small space for settling the ore; furthermore, the undulations of the table make its action irregular, and consequently the best rotary table delivers a sandy product and rich tailings.

Now by my invention I overcome all these difficulties. I first subject the material to be treated to the action of my automatic stream classifier, which is illustrated in figure 1, and is for separating fine grains from slime. A is a cylinder of sheet iron, about 30 inches in diameter and 5 feet high, with a funnel-shaped bottom (B), ending in a curved pipe (C) with horizontal opening (D). A sheet-iron partition (E) divides the upper part of the cylinder (down to about two-fifths of its depth) into two equal parts; a sieve (F), with holes wide enough for all grains of the ground or stamped stuff, covers the funnel. The upright open end of a water-pipe (G), two inches to three inches in diameter, passes through the sieve. A branch of the same pipe is connected with the sheet-iron vessel (I), by an india-rubber hose (K). Above the branch (H) a cock (L) is inserted into the water pipe. A lever (M) supports on one end the counter-weight (N), and on the other the vessel (I), swinging in the forked end of the lever. A small strip of sheet-iron (Q) is inserted into the spout of the vessel (I), leaving a narrow open space between it and the bottom of the spout. Two iron rods (O) hanging on the vessel (I), support an iron flat dish (P). Water is supplied to the pipe (G) under pressure.

The stamped ground or dissolved stuff mixed with water enters through the gutter (R) and meets the current of water ejected from the pipe (G) and regulated by the cock (L) so that its force suffices to keep all slimy particles suspended in the current which passes from the gutter (R) underneath the partition (E) to the spout (S). To maintain this current the edge (T) of the influx is situated a few inches higher than that of the overflow (U).

The grains pass through the pipe (C) fill the bottom of the dish (P) as well as the funnel (B), but as soon as the grains begin to deposit above the sieve (F) the pipe (G) is choked and the water passes through (H) and (K) into the vessel (I) fills it up to the level (2) and presses it down, at the same time opening the pipe (C) at (D). In course of a few seconds the pipe (C) and the funnel (B) are emptied, enabling the water to pass out again from (G). The vessel (I) not being further supplied with water gets lighter as the water flows out underneath (Q) and remaining at the level (1) the counter weight (N) overbalances the weight of (I) lifts it and also the dish (P).

The action of the apparatus is automatic, no attendance is required after the weights are regulated and the cock (L) adjusted according to the size of the grains.

The granular stuff is carried on little trucks to my round jigger while the slimy stuff runs through the gutter (J) to one of my circular separating tables.

My round jigger for extracting the ore from the granular stuff is shown in figure 2.

A is a circular box of sheet iron or board, four feet high, and seven feet nine inches in diameter, the lower part of it is divided by four partitions (B B) two feet high, into four equal compartments, each forming a gutter beginning in the centre (C) and ending in the outlet (D D) with pipes (E).

(F) is a pipe for clean water with cock (F') for regulating the force of the jet of water emanating from (C); (G) is a ring-shaped sieve of sheet iron or copper with holes suitable for the grains say of one twentieth of an inch in diameter, the holes being punched out leaving both surfaces of the sieve smooth; (H) is a layer of iron punches (round pieces of sheet iron, of three twenty-fifths of an inch in diameter resulting from punching sieves) three inches high. (I) is a circular box with a wooden piston (K), the piston rod (K') is connected with an eccentric (K<sup>u</sup>) driven by the pulley (K<sup>m</sup>) and belt. The box (I) is open on the lower end, the upper end being covered by a truncated cone of sheet iron (L), the upper end of which supports the circular gutter (M); (N N) are two pipes feeding the gutter (M), with the stuff to be treated and mixed with water. The box (A) is filled with water up to the surface of the layer of punches (H). The stuff passes from the gutter (M) through holes on the bottom of the outer wall over the cone (L) into the circular gutter (P), and through short pipes (Q) under the surface of the layer of punches (H). Here it is exposed to three different influences, viz., the force of its own current, that of the current of fresh water ejected from pipe (F), and the pushing action of the piston (K), the latter making (according to the fineness of the grains three hundred to six hundred vibrations per minute of 0", 4 to 0", 12 length of stroke).

The

*Improvements in Machinery for Extracting Ores and Metals from Minerals, &c.*

The result is as follows:—The water rises and overflows on the periphery  $O^1$ , into the circular gutter (O), leading to the tailings and generating a constant current in and above the layer of punches from the centre of the box to the periphery; the stuff entering the layer through the pipe (Q) is following this current, but is interrupted in its proceeding by the current of clean water from (F) which tries to bring it on the surface, and succeeds best with those grains of lower specific gravity, whilst the heavier particles tend to deposit on the sieve and to pass through it. This action is delayed by the pushing motions of the piston (K), by which short vibrating waves are generated lifting up the layer of punches, at short intervals, and sucking it down to the sieve. It is evident that the stuff exposed to this treatment is divided according to the specific gravity of its component parts, those of lower specific gravity are thrown up to the surface of the layer and floated off into (O), whilst the heavier particles pass through the punches and the sieve, deposit in one of the gutters (B), and pass out from the box through the pipes (E). The mouth of the pipe (E) is closed by a wooden stopper through the centre of which a hole is bored so as to allow the ore to pass out with a small quantity of water.

The working of the apparatus is to be regulated according to the specific gravity of the ore and the size of the grains, by altering the number of vibrations of the piston (K), and the length of its stroke, and also by modifying the jet of water from the pipe (F).

This apparatus has a great advantage over all kinds of jiggers or shaking tables, as the stuff entering near the centre of the box is by proceeding to the periphery spread over a continuously increasing surface.

My circular conical separating table is for extracting the ore from the slimes. One form of it is shown in figure 3, and another in figure 4; figure 3 shows a single, and figure 4 a treble table both acting in a similar manner.

Referring to figure 3 (A) is the table erected in masonry or brickwork and covered with cement; its surface is a conical shape with an incline of one-ninth to one-twelfth, according to the specific gravity of the ore to be extracted. It is necessary that the surface be carefully smoothed in the shape of a truncated cone, the top of which is situated in the centre of the vertical spindle (B).

The diameter of the basis can vary from twenty to thirty feet more.

The lower edge of the table projects over the brickwork, enabling the water to drop into a gutter and not to adhere to the brickwork; (B) is a rotating vertical spindle driven by a screw (C) and tangent wheel (D), the former receiving its impulse by pulley and belt. The spindle (B) carries with it the following parts, viz. :—

Four iron girders I shaped (E), fixed to the spindle by the cast-iron rose (F). The thus curved sheet iron ( $G^1 G^1$ ),  $G^1$  being wider than  $G^1$  the former extends over an angle of about thirty to forty degrees, the latter over an angle of one hundred and fifty, to one hundred and forty degrees; the curved gutter (H) for clean water with perforations in its bottom, the feeding pipe ( $P^1$ ) of the said gutter, the pipe (J) for clean water containing on one side small mouth pieces like gas burners, for ejecting water, and its feeding pipe ( $P^{11}$ ), the circular basin (K) for clean water with its overflow pipe (W); (this basin is fed by the stationary pipe (L). The circular iron gutter ( $O^{11}$ ), for slime (which enters into it by aid of the stationary pipe (M), the conically shaped distributing plate (O), the semi-circular gutter ( $O^{11}$ ) for clean water with its feeding pipe (P).

All the above mentioned parts are rotating together with the spindle (B).

The circular gutter (in brickwork) surrounding the table is divided by two or more vertical sheet iron plates into three or more concentric gutters (S Q R) for receiving the three or more kinds of separated stuff, and being in connection by aid of pipes ( $S^1 Q^1 R^1$ ) respectively, with two basins ( $S^{11}$ ) for lighter, ( $Q^{11}$ ) for heavy ores, and with the gutter ( $R^{11}$ ) for worthless slime of the gangue.

The spindle (B) with all parts fixed to it is rotating in the direction of the arrows. The table operates as follows :—

The slime entering through the syphon-like pipe (M) fills circular feeding gutter ( $O^{11}$ ), and passes through holes near its bottom over that part of the distributing plates which is marked ( $O^1$ ), and hatched. The section of the table between the radius (J) and (I) is covered with slime which runs downwards, depositing the heaviest particles next to the centre, the less heavy one near the periphery, whilst the water with the poor sand is floated over the curved plate ( $G^1$ ), into the gutter (R) leading to the tailings. Between the radius (T) and (V) clean water flows down from gutter ( $O^{11}$ ) lifting again the lighter ores from the deposited stuff and carrying it into the gutter (S). This action is supported by the curved basin (H) from whence a rain of water falls on the table. The position of the basin (H) is oblique to the table so that every radius of the table is sprinkled with water from every point of the rotating basin (H) from ( $H^1$ ) to ( $H^{11}$ ), thus lifting the lighter ore and carrying it into the gutter. If all is well regulated the section between the radius (V) and (J) is carrying nothing but the heaviest ore which is washed off by the jets of water from the pipe (J), and runs over the curved plate (G) into the gutter (Q). By this operation the table is thoroughly cleaned near (J).

The means to regulate the table according to the kind of ore under treatment are reducing or enlarging the outlet ( $O^1$ ), of the feeding gutter ( $O^{11}$ ), and the curved plate ( $G^1$ ) reducing or enlarging the curved plate (G), if the ore is clean before the radius (V) passes it, altering the position, length, and number of the curved basins (H), altering the incline of the table, altering the length of the spindle between the table and the beams (E), by which the pressure of the water pipes ( $P^1 P^1 P^{11}$ ) is also altered, adding one or more gutters, to the circular gutters (Q R S), and consequently, altering the width of the curved plates ( $G^1 G^1$ ).

Figure 4 shows the arrangement of a treble table of the same kind. The lowest table is supported on the periphery by brickwork and by eight iron beams ( $K^{11}$ ), the upper ones are supported by eight cast-iron inclined pillars (L), which are connected with the eight iron beams (K), respectively ( $K^1$ ).

The beams ( $K K^1 K^{11}$ ) are covered with sheet iron on which is a layer of beton (gravel and cement), having a smooth surface.

The vertical spindle (B) is hollow, and supports on its top a cylindrical basin (P) for clean water, rotating with the spindle and supplied by the fixed pipe (Q). A small pipe open at both ends and soldered in the bottom of the basin (P) keeps a constant water level in the latter; overflowing water passes through this pipe into the fixed basin (R).  
The

*Improvements in Machinery for Extracting Ores and Metal from Minerals, &c.*

The pipes for clean water on the three tables (E E' E'', D D' D''), are supplied from the hollow spindle (B).

The slime goes to the different tables through fixed pipes (G G' G''). The distribution of same as well as that of clean water is effected in the same way as with the single table. But there is a difference between both in the construction of the gutters receiving the washed off stuff and in the gear for driving the rotating parts.

The gutters H H H H in brickwork are destined to carry off the different kinds of ore (in figure 4, for three kinds of ore and tailing) ; a circular iron gutter (N) surrounds the whole table, is supported by iron wheels running on a circular rail which is laid down on the brickwall between the two inner gutters (H H). This iron gutter forms at once a pulley for a rope (S) driven by the engine. The rope passes over the pulley (M), goes round the gutter (N), and back again over a second pulley (M). The water pipe (E'') of the lowest table is connected with the circulating gutter (N) by aid of two angle irons by which the rotating motion of the gutter is transmitted to the spindle (B). As it is evident that the different kinds of ore and tailings can only be floated into the rotating gutter (N), at certain distances from the pipe (E''), the said gutter is divided in its length into as many parts as there are gutters (H), each part of the rotating gutter corresponding with one of the circular gutters (H). Short bent pipes (J) of different length lead the efflux from the partitions of the iron gutter (N) into the corresponding gutter (H).

The gutters (F F') of the upper tables are fixed, their bottoms are not horizontal but form funnels ending in fixed spouts leading to the similar gutter of the table next below. The distance between these pipes is about two feet. As the operation on the three tables is identical in every vertical section the similar products of the three tables must go in the same division of the circulating gutter (N), and by means of the pipes (J) into the corresponding gutter (H).

Having thus described the nature and object of my several improvements and the manner of performing the same, I would have it understood that what I believe to be new, and therefore claim as my invention is—

First—My automatic stream classifier for separating from crushed or ground minerals, or other metalliferous material, the grains from the slime by aid of an automatically working apparatus in which a vertical stream of water lifts the slimy parts and floats them away whilst it permits the grains to pass through it to the bottom, substantially as hereinbefore described and as shown in figure 1 of my drawings.

Second—The special contrivances in my automatic stream classifier for regulating the periodical efflux of the grains without interrupting the action of the apparatus, substantially as herein described and explained.

Third—My round jigger having its feed at the centre and an upright vertical stream of water in the centre below assisting to float the lighter particles, and having a layer of iron punches on the sieve through which the ore passes, substantially as herein described and explained and as illustrated in figure 2 of my drawings.

Fourth—My stationary conical cemented table with feed at the centre, and with rotating feeder, cleaner, distributing plate, or distributing gutter, in single double or treble form, substantially as hereinbefore described, and as illustrated in figures 3 and 4 of my drawings.

In witness whereof, I, the said Carl Wagemann, have hereto set my hand and seal, this twenty-third day of January, one thousand eight hundred and eighty-three.

Witness—

EDWD. WATERS,  
Melbourne, Patent Agent.

C. WAGEMANN.

This is the specification referred to in the annexed Letters of Registration granted to Carl Wagemann, this ninth day of April, A.D. 1883.

AUGUSTUS LOFTUS.

## REPORT.

Sir,

Having examined the specification and drawings accompanying the Petition of Mr. Carl Wagemann, for Letters of Registration for an invention entitled "Improvements in Machinery for Extracting Ores and Metals from Minerals and other metalliferous material after being ground or crushed," we have the honor to state that we see no objection to issue of Letters of Registration, as prayed for.

We have, &c.,

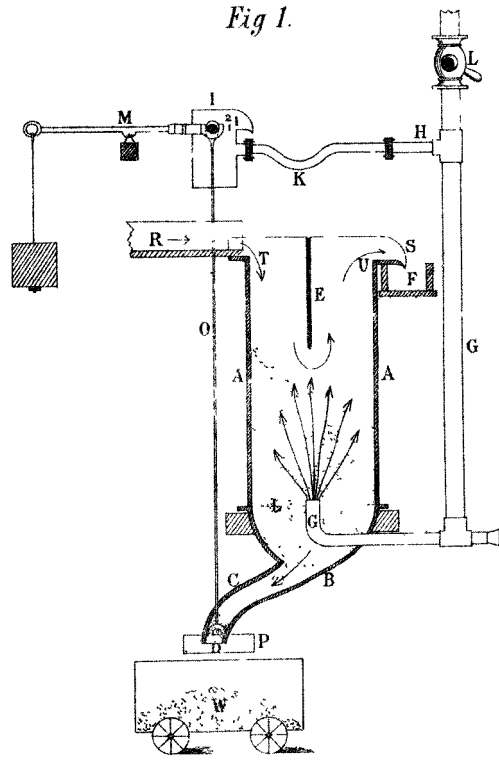
A. LEIBIUS.  
CHAS. WATT.

The Under Secretary of Justice.

[Drawings—one sheet.]

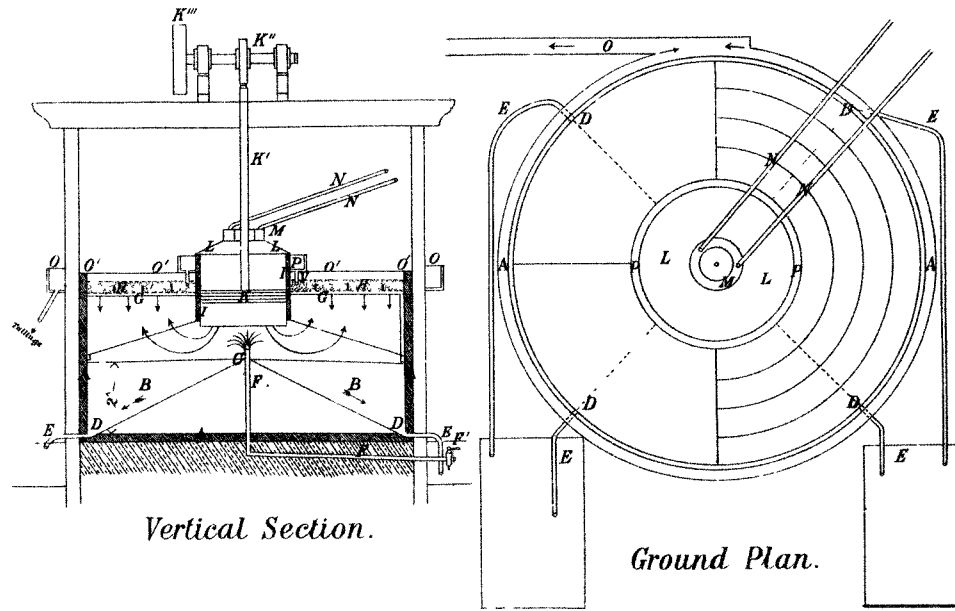


Fig 1.



Vertical Section.

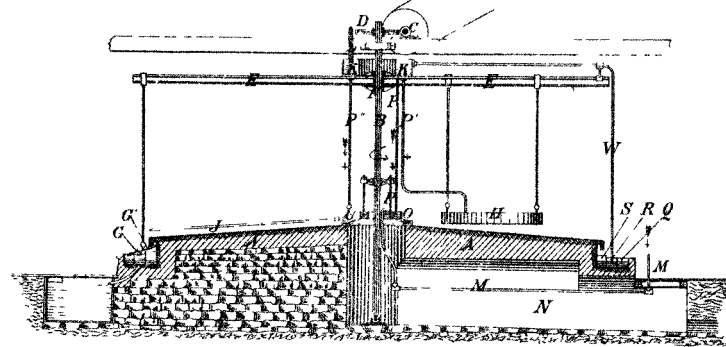
Fig 2.



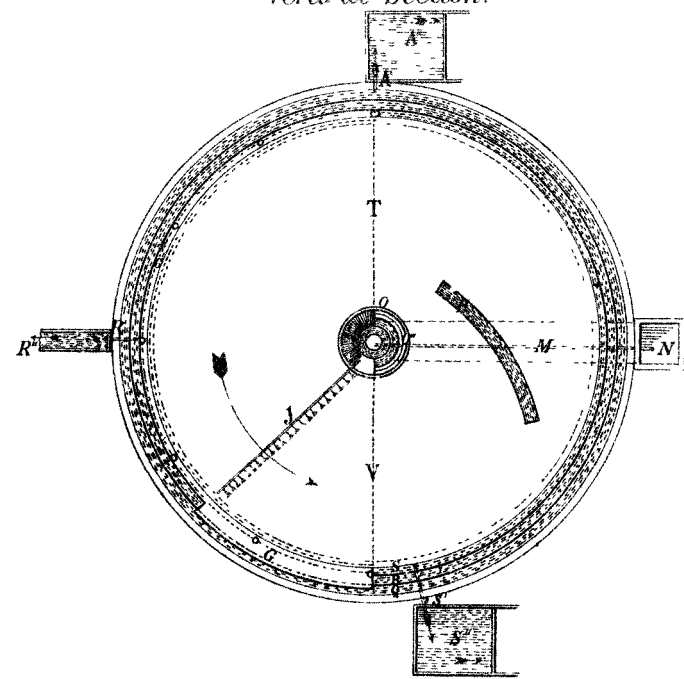
Vertical Section.

Ground Plan.

Fig 3.

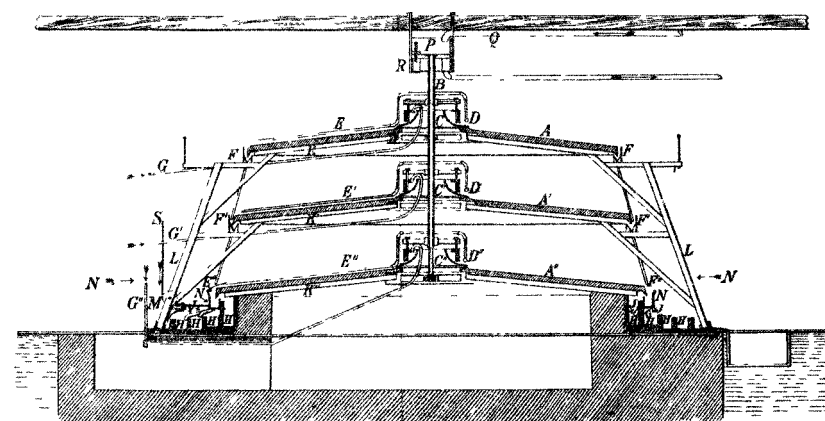


Vertical Section.



Ground Plan.

Fig 4.



Vertical Section.

PHOTO-LITHOGRAPHED AT THE GOVT. PRINTING OFFICE, SYDNEY, NEW SOUTH WALES.

This is the Sheet of Drawings referred to in the annexed Letters of Registration granted to Carl Wagemann, this ninth day of April, A. D. 1883.

Augustus Loftus.

Fig. 35.



A.D. 1883, 9th April. No. 1217.

IMPROVED PROCESS FOR EXTRACTING PRECIOUS METALS FROM THEIR ORES.

LETTERS OF REGISTRATION to Alfred Kirby Huntington and Walter Edward Koch, for an invention entitled "An Improved Process for extracting Precious Metals from their Ores."

[Registered on the 10th day of April, 1883, in pursuance of the Act 16 Vic. No. 24.]

BY HIS EXCELLENCY THE RIGHT HONORABLE SIR AUGUSTUS WILLIAM FREDERICK SPENCER LOFTUS (commonly called LORD AUGUSTUS LOFTUS), Knight Grand Cross of the Most Honorable Order of the Bath, a Member of Her Majesty's Most Honorable Privy Council, Governor and Commander-in-Chief of the Colony of New South Wales and its Dependencies.

TO ALL TO WHOM THESE PRESENTS SHALL COME, greeting:

WHEREAS ALFRED KIRBY HUNTINGTON, of King's College, Strand, and WALTER EDWARD KOCH, of Kensington, both in the county of Middlesex, England, have by their Petition humbly represented to me that they are the authors or designers of a certain invention or improvement in manufactures, that is to say, of an invention entitled "An improved process for extracting Precious Metals from their Ores," which is more particularly described in the specification which is hereunto annexed; and that they, the said Petitioners, have deposited with the Honorable the Treasurer of the said Colony of New South Wales the sum of Twenty Pounds sterling for defraying the expense of granting these Letters of Registration, as required by the Act of Council, sixteenth Victoria, number twenty-four; and have humbly prayed that I would be pleased to grant Letters of Registration, whereby the exclusive enjoyment and advantage of the said invention or improvement might be secured to them for a period of fourteen years: And I, being willing to give encouragement to all inventions and improvements in the arts or manufactures which may be for the public good, and having received a report favourable to the prayer of the said Petition, from competent persons appointed by me to examine and consider the matters stated therein, and to report thereon for my information, am pleased, with the advice of the Executive Council, and in exercise of the power and authority given to me by the said Act of Council, to grant, and do by these Letters of Registration grant unto the said Alfred Kirby Huntington and Walter Edward Koch, their executors, administrators, and assigns, the exclusive enjoyment and advantage of the said invention or improvement, for and during the term of fourteen years from the date hereof; to have, hold, and exercise unto the said Alfred Kirby Huntington and Walter Edward Koch, their executors, administrators, and assigns, the exclusive enjoyment and advantage thereof, for and during and unto the full end and term of fourteen years from the date of these presents next and immediately ensuing, and fully to be complete and ended: Provided always, that if the said Alfred Kirby Huntington and Walter Edward Koch shall not, within three days after the granting of these Letters of Registration, register the same in the proper office in the Supreme Court at Sydney, in the said Colony of New South Wales, then these Letters of Registration, and all advantages whatsoever hereby granted, shall cease and become void.

In witness whereof, I have hereunto set my sign manual, and have caused the present Letters of Registration to be sealed with the seal of the said Colony of New South Wales, at Government House, Sydney, in New South Wales, this ninth day of April, in the year of our Lord one thousand eight hundred and eighty-three.

[L.S.]

AUGUSTUS LOFTUS.

---

*An improved process for extracting Precious Metals from their Ores.*

---

SPECIFICATION of ALFRED KIRBY HUNTINGTON, of King's College, Strand, and WALTER EDWARD KOCH, of Kensington, both in the county of Middlesex, England, for an invention entitled "An improved process for extracting Precious Metals from their Ores."

OUR invention relates to a process for extracting precious metals from their ores. For this purpose we first calcine the ore under an oxydating flame, so as to drive off sulphur and other impurities, and for this purpose we operate preferably in a rotative furnace, so as to keep the ore in agitation while it is undergoing calcination. When the ore is sufficiently calcined, as we can ascertain by testing a sample taken from the furnace, we transfer it still hot to a pan or vessel arranged as follows:—It is a close vessel, set in a flue, to receive heat preferably from a gas flame. Within the vessel there is a revolving agitator, which keeps the calcined ore in agitation over a quantity of lead, which is molten, and occupies the lower part of the pan; a pipe leads from a gas producer to the upper part of the pan, and an outlet pipe carries the gas from the pan to the fire or furnace where it is burnt to heat the pan. Thus, while the ore remains agitated at a temperature insufficient to frit it, in the presence of the molten lead the carbonaceous or deoxydating gas from the producer is kept circulating through the pan. The melted lead in the pan takes up the precious metal from the ore, and when the extraction is carried sufficiently far, a side door of the pan is opened, and the arms of the agitator throw out the residue of the ore, when a fresh charge of calcined ore can be introduced. The lead may continue in the pan to receive the precious metal from a number of successive charges of ore until it is sufficiently saturated, when it is run off by a tapping hole, to be treated by cupellation or otherwise, to separate the precious metal from it. Although we have mentioned lead as a suitable metal for taking up the precious metal from the ore, it is to be understood that other metals that fuse at a moderate heat, such as tin, antimony, or zinc, or alloys or mixtures of these, may be employed.

We find that an alloy of lead and antimony is particularly suitable for the purpose.

We claim as our invention—

The herein described process for extracting precious metals from ore by calcining the ore, and then subjecting the calcined ore to heat and agitation in a deoxydating atmosphere, in presence of melted metal, such as lead, zinc, or their equivalents.

In witness whereof, we, the said Alfred Kirby Huntington and Walter Edward Koch, have hereunto set our hands and seals, this fourteenth day of December, in the year of our Lord one thousand eight hundred and eighty-two.

ALFRED KIRBY HUNTINGTON.  
WALTER EDWARD KOCH.

Witness—

JNO. P. M. MILLARD.

This is the specification referred to in the annexed Letters of Registration granted to Alfred Kirby Huntington and Walter Edward Koch, this 9th day of April, A.D. 1883.

AUGUSTUS LOFTUS.

---

REPORT.

---

Sir,

Sydney, 6 February, 1883.

We do ourselves the honor to return to you the documents transmitted to us under your B.C. communication of 29th ultimo, No. 83-1,672, which have reference to Messrs. Huntington and Koch's invention, termed "An improved process for extracting Precious Metals from their Ores," and we have to report that we see no objection to the issue of the Letters of Registration asked for, in terms of Messrs. Huntington and Koch's Petition, specification, and claim.

We have, &c.,  
A. LEIBIUS  
CHAS. WATT.

The Under Secretary of Justice.

---




---

A.D. 1883, 13th April. No. 1218.

---

AN IMPROVED TREATMENT FOR PRESERVING HIDES AND SKINS.

LETTERS OF REGISTRATION to Jules Louis Moret, for an invention entitled  
 “An Improved treatment for Softening, Unhairing, Puring, Ungreasing, and  
 Preserving Hides and Skins.”

[Registered on the 14th day of April, 1883, in pursuance of the Act 16 Vic. No. 24.]

BY HIS EXCELLENCY THE RIGHT HONORABLE SIR AUGUSTUS WILLIAM FREDERICK SPENCER LOFTUS  
 (commonly called LORD AUGUSTUS LOFTUS), Knight Grand Cross of the Most Honorable Order of  
 the Bath, a Member of Her Majesty's Most Honorable Privy Council, Governor and Commander-in-  
 Chief of the Colony of New South Wales and its Dependencies.

TO ALL TO WHOM THESE PRESENTS SHALL COME, greeting :

WHEREAS JULES LOUIS MORET, of Paris, in the Republic of France, hath by his Petition humbly represented to me that he is the author or designer of a certain invention or improvement in manufactures, that is to say, of an invention entitled “An Improved treatment for Softening, Unhairing, Puring, Ungreasing, and Preserving Hides and Skins,” which is more particularly described in the specification which is hereto annexed; and that he, the said Petitioner, hath deposited with the Honorable the Treasurer of the said Colony of New South Wales the sum of Twenty Pounds sterling, for defraying the expense of granting these Letters of Registration, as required by the Act of Council, sixteenth Victoria, number twenty-four; and hath humbly prayed that I would be pleased to grant Letters of Registration, whereby the exclusive enjoyment and advantage of the said invention or improvement might be secured to him for a period of fourteen years: And I, being willing to give encouragement to all inventions and improvements in the arts or manufactures which may be for the public good, and having received a report favourable to the prayer of the said Petition, from competent persons appointed by me to examine and consider the matters stated therein and to report thereon for my information, am pleased, with the advice of the Executive Council, and in exercise of the power and authority given to me by the said Act of Council, to grant, and do by these Letters of Registration grant unto the said Jules Louis Moret, his executors, administrators, and assigns, the exclusive enjoyment and advantage of the said invention or improvement, for and during the term of fourteen years from the date hereof; to have, hold, and exercise unto the said Jules Louis Moret, his executors, administrators, and assigns, the exclusive enjoyment and advantage thereof, for and during and unto the full end and term of fourteen years from the date of these presents next and immediately ensuing, and fully to be complete and ended: Provided always, that if the said Jules Louis Moret shall not, within three days after the granting of these Letters of Registration, register the same in the proper office in the Supreme Court, at Sydney, in the said Colony of New South Wales, then these Letters of Registration, and all advantages whatsoever hereby granted, shall cease and become void.

In witness whereof, I have hereunto set my sign manual, and have caused the present Letters of Registration to be sealed with the seal of the said Colony of New South Wales, at Government House, Sydney, in New South Wales, this thirteenth day of April, in the year of our Lord one thousand eight hundred and eighty-three.

[L.S.]

AUGUSTUS LOFTUS.

*An Improved Treatment for Preserving Hides and Skins.*

TO all to whom it may concern: Be it known that I, JULES LOUIS MORET, of Paris, in the Republic of France, have invented or discovered an improved treatment for softening, unhairing, puring, ungreasing and preserving hides and skins, and I, the said Jules Louis Moret, do hereby declare the nature of the said invention and in what manner the same is to be performed, to be particularly described and ascertained in and by the following statement thereof, that is to say:—

This invention has for its object to enable hides and skins of all kinds to be immediately unhaird and prepared for tanning, or to be preserved in a fresh state for a limited time, or in a dried state for any requisite length of time, for transport or storage. It obviates the difficulties which have hitherto existed in treating skins or hides, arising from danger of dry cracking, or putrefaction, or from the attacks of vermin or insects, and it further enables the hides and skins to be at once unhaird after being so preserved, without further treatment other than a few hours steeping in pure water. It has also for its object to effect the ungreasing of sheep and other skins, and the softening of China hides, East India kips, and other dried hides and skins, by a more efficient and economical method than any hitherto employed or endeavoured to be applied for like purposes.

This improved treatment of hides and skins, with a view to immediate unhairing, is essentially inoffensive in its character, and it comprises two operations, viz.:—(1) the unhairing process proper, and (2) what is termed a scudding, puring, and ungreasing operation, in which, however, offensive "bate" is dispensed with, thereby effecting a great improvement over the old processes, while the undergrowth down or remaining short hair left after the first operation is removed with success, and in such a state that it is fit to be used for various purposes as what may be termed raw material.

The first of these operations may be performed in either of two ways (except when sheep skins are being treated), viz., by immersion or by application with a brush or mop, the strength of the composition or chemical agent employed being adapted in the respective cases to the mode of use. In the case of sheep skins, the second alternative method only is employed, viz., the application of the composition with a brush or mop on the flesh side, in order to avoid injury to the wool.

The composition forming the solutions or liquors employed in these two above mentioned operations, according to this invention, is prepared in the following way:—A solution of what is known commonly as American potash, or of ordinary caustic potash, is made of the required strength and is raised to a temperature of from 180° to 200° F. I then add (stirring the composition well meanwhile by means of an agitator) about 2 oz. to 3½ oz. of realgar in powder to each pound (avoirdupois) of potash employed, together with or without the further addition of 3 oz. 5 oz. or 7 oz. of quicklime for each pound of potash, the proportions depending on the kind of potash used and on the manner in which the composition is to be applied or used.

The quicklime may be omitted when the potash is found to be sufficiently strongly caustic without adding the lime, and it is to be noted that the employment of quicklime in the composition used according to this invention is limited to those cases where it is required in order to ensure that the potash is sufficiently caustic, and only so much should be used in any case as may be required to effect this object. By observing this precaution and following the method of treatment of this invention, the inconveniences arising from stench caused by using what is termed "bate" or otherwise which have been hitherto experienced in the ordinary treatment of hides and skins are obviated, and this is one of the great advantages obtained by the use of this improved process of treatment.

The composition is allowed to settle and the clear liquor decanted off and is in that state employed with great advantage in either of the following ways:—

1st. For application with a brush or mop to the flesh side of the hide or skin for the purpose of unhairing the same the composition is reduced to the proper strength by the addition of the required quantity of water. The strength of the decanted composition for light skins is to be from about 8° to 14° Beaumé, and for heavy skins and hides from about 12° to 14° Beaumé.

2nd. To form a vat or bath in which the hides and skins are to be immersed (for the purpose of removing the undergrowth or down, for scudding, puring, and ungreasing), the composition is still more diluted with water, the strength in this case being from about 1° to 4°, according to the nature of the skin.

To form a vat or bath in which the hides and skins are to be immersed as a first operation for the purpose of unhairing them, I wash with water, two or more times until exhausted, the residue left after drawing off the clear liquor in preparing the above mentioned composition, stir up well, let settle, and draw off clear, and with these clear washing waters added together I make a saturated solution of potash. I reduce this with water to from ½° to 8° Beaumé.

Instead of washing the residue left from the preparation of a previous composition, I may make the vat or bath at once in the same way as above described for the composition itself, the proportions in this case being 1 oz. (more or less) of realgar and 2 oz., 4 oz., or 5 oz. of quicklime to each pound of potash employed. The quicklime may however be dispensed with in this case also when the potash is strongly caustified.

For the purpose of preserving hides and skins for transport and preparing them for unhairing at any subsequent time by a simple steeping in water, I use a solution of American potash at 8° to 15° with the addition of 30 grains (or more) of salicylate of soda or other preservative salt to every cwt. of composition at 10° B., the composition being in this case applied either with a brush or mop or by immersion, the hides or skins being left in this state or dried, according as they are to be kept a greater or less length of time. In the dry preserved state they may be kept for an indefinite period, and may be at any subsequent time restored to their original green and natural condition by simply steeping them for about 12 hours in water, when the hair and scud may be removed without further treatment with chemical agents. The water in which the preserved hides and skins have been so steeped serves for preparing the baths or vats used in the first and second operations. This mode of preservation forms an admirable substitute for the salting treatment hitherto generally used for preserving hides, and renders unnecessary the injurious liming or other treatment for unhairing. The quality of the leather obtained from hides thus preserved by my improved process will be found to be superior to that of hides treated in the ordinary way.

The

---

*An Improved Treatment for Preserving Hides and Skins.*

---

The softening of China hides, East India kips, and other dried hides is effected by steeping in a very weak solution ( $\frac{1}{3}^{\circ}$  Beaumé) of either of the above mentioned compositions.

I do not limit myself to the use of caustic potash, as I may use caustic soda in place of the potash, or may use both caustic potash and caustic soda together.

Having thus described the nature of my invention, and the manner of performing the same, I declare that what I claim as my invention is:—

- 1st. The herein described method of effecting, by means of the agents referred to, the unhairing of hides or skins by an economical and efficient and at the same time comparatively inoffensive process substantially, as set forth.
- 2nd. The herein described method of effecting the successive operations of unhairing, scudding, puring, and ungreasing hides and skins, substantially in the manner and by means of the agents herein specified.
- 3rd. The use of the chemical agents employed in the above mentioned method of treatment, combined with a salicylate or other preservative salt for treating and preserving hides and skins, and the production of hides in a preserved state ready for being unhaired after a simple steeping process substantially, as herein described.

The above specification of my invention, signed by me, this fourteenth day of December, A.D. 1882.

JULES LOUIS MORET.

---

This is the specification referred to in the annexed Letters of Registration granted to Jules Louis Moret, this 13th day of April, A.D. 1883.

AUGUSTUS LOFTUS.

---

REPORT.

Sir,

Sydney, 15 February, 1883.

The application of Mr. Jules Louis Moret, of Paris, for Letters of Registration for "An Improved process for softening, unhairing, puring, ungreasing, and preserving hides and skins," having been referred to us, we have examined the specification accompanying the same, and we have now the honor to report that we see no objection to the issue of Letters of Registration as prayed for.

We have, &c.,

CHAS. WATT.

EDMUND FOSBERY.

The Under Secretary of Justice.

---



A.D. 1883, 13th April. No. 1219.

IMPROVEMENTS IN MOULDING POTTERY BY PRESSURE.

LETTERS OF REGISTRATION to Samuel Crowder, for an invention entitled  
 "Improvements in moulding Pottery by pressure."

[Registered on the 14th day of April, 1883, in pursuance of the Act 16 Vic. No. 24.]

BY HIS EXCELLENCY THE RIGHT HONORABLE SIR AUGUSTUS WILLIAM FREDERICK SPENCER LOFTUS  
 (commonly called LORD AUGUSTUS LOFTUS), Knight Grand Cross of the Most Honorable Order of the  
 Bath, a Member of Her Majesty's Most Honorable Privy Council, Governor and Commander-in-Chief  
 of the Colony of New South Wales and its Dependencies.

TO ALL TO WHOM THESE PRESENTS SHALL COME, greeting :

WHEREAS SAMUEL CROWDER, of Durban, Port Natal, hath by his Petition humbly represented to me that he is the author or designer of a certain invention or improvement in manufactures, that is to say, of an invention entitled "Improvements in moulding Pottery by pressure," which is more particularly described in the specification and the sheet of drawings, which are hereunto annexed ; and that he, the said Petitioner, hath deposited with the Honorable the Treasurer of the said Colony of New South Wales the sum of Twenty Pounds sterling, for defraying the expense of granting these Letters of Registration, as required by the Act of Council, sixteenth Victoria, number twenty-four ; and hath humbly prayed that I would be pleased to grant Letters of Registration, whereby the exclusive enjoyment and advantage of the said invention or improvement might be secured to him for a period of fourteen years : And I, being willing to give encouragement to all inventions and improvements in the arts or manufactures which may be for the public good, and having received a report favourable to the prayer of the said Petition, from competent persons appointed by me to examine and consider the matters stated therein and to report thereon for my information, am pleased, with the advice of the Executive Council, and in exercise of the power and authority given to me by the said Act of Council, to grant, and do by these Letters of Registration grant unto the said Samuel Crowder, his executors, administrators, and assigns, the exclusive enjoyment and advantage of the said invention or improvement, for and during the term of fourteen years from the date hereof ; to have, hold, and exercise unto the said Samuel Crowder, his executors, administrators, and assigns, the exclusive enjoyment and advantage thereof, for and during and unto the full end and term of fourteen years from the date of these presents next and immediately ensuing, and fully to be complete and ended : Provided always, that if the said Samuel Crowder, shall not, within three days after the granting of these Letters of Registration, register the same in the proper office in the Supreme Court, at Sydney, in the said Colony of New South Wales, then these Letters of Registration, and all advantages whatsoever hereby granted, shall cease and become void.

In witness whereof, I have hereunto set my sign manual, and have caused the present Letters of Registration to be sealed with the seal of the said Colony of New South Wales, at Government House, Sydney, in New South Wales, this thirteenth day of April, in the year of our Lord one thousand eight hundred and eighty-three.

[L.S.]

AUGUSTUS LOFTUS.

---

*Improvements in moulding Pottery by pressure.*

---

TO ALL TO WHOM THESE PRESENTS SHALL COME, I SAMUEL CROWDER, of Durban, Port Natal, send greeting.

WHEREAS I, the said Samuel Crowder, am the inventor of certain improvements for "Moulding Pottery by pressure." Now know ye, that I, the said Samuel Crowder, do hereby declare, the nature of my said improvements, and in what manner the same are to be performed, to be particularly described and ascertained in and by the following statement, that is to say,—My invention consists of using moulds made of metal and heated by steam or other means for the formation of Pottery, and of the machines for effecting it, as more fully shown by the drawings attached hereto. The lower mould is surrounded by a tight box, into which steam, water, or hot air is admitted; the upper mould or plunger is also heated, and when forced down into the lower one, leaves the article of the thickness required. The necessary pressure may be obtained by steam cylinder acting direct by hydraulic pressure by lever, screw, or other means, and so applied as to either lower the upper or raise the lower mould. At the bottom of the lower mould a valve is fitted, which can be raised and lowered by hand lever or by a treadle; with this valve, after the inner mould is withdrawn, the workman raises the thing moulded, and enables the attendant to remove it to the drying room. In moulding flower pots, or other things requiring a hole at the bottom, the upper mould is supplied with a plug which fits into a hole in the valve, and the piece of material punched out falls down the hollow shank of the treadle by which the valve is actuated. For moulding articles having handles or ornaments on the outside, the upper mould is made and acted upon in the same manner as for plain goods, but the lower mould is made in three pieces, fitting accurate when brought into contact (as by drawing attached), the piece forming the bottom is firmly bolted on to a lathe led immediately under centre of the upper mould; two movable slides are put on the lathe led, and to these the sides of the mould are bolted as shown; and when all are brought together by the lever motion, an iron clamp hinged at the back of machine is brought over the mould and forced tight, the material is then put into the mould, the upper mould descends, and when the sides of the mould are forced apart by reversing the levers, the thing moulded is left standing on the stationary bottom, and can be at once removed to the drying room. For making plates and dishes and such things, loose removable moulds may be used for each article, in order to maintain the shape while drying (and in all cases some lubricant may be used), the loose moulds being heated in an oven or steam box, or water.

CLAIMS.

Having fully described and ascertained my invention, I wish it to be distinctly understood that what I claim as my invention, and for which I now seek protection, is the process of moulding pottery by pressure instead of on the potter's wheel, substantially as described herein and as shown in the drawings herewith.

Witness—

JNO. FAIRFAX CONIGRAVE,  
Licensed Patent Agent, Adelaide.

SAMUEL CROWDER,  
By his duly authorized Attorney, W. N. CROWDER.

—

This is the specification referred to in the annexed Letters of Registration granted to Samuel Crowder, this thirteenth day of April, A.D. 1883.

AGUSTUS LOFTUS.

REPORT.

—

Sir,

Sydney, 13 February, 1883.

Having examined the plan and specification accompanying the Petition, we have the honor to recommend that Letters of Registration should be issued to Mr. Samuel Crowder, for the invention entitled "Moulding Pottery by pressure," as shown in the drawing, and described in the specification attached to the Petition.

We have, &c.,

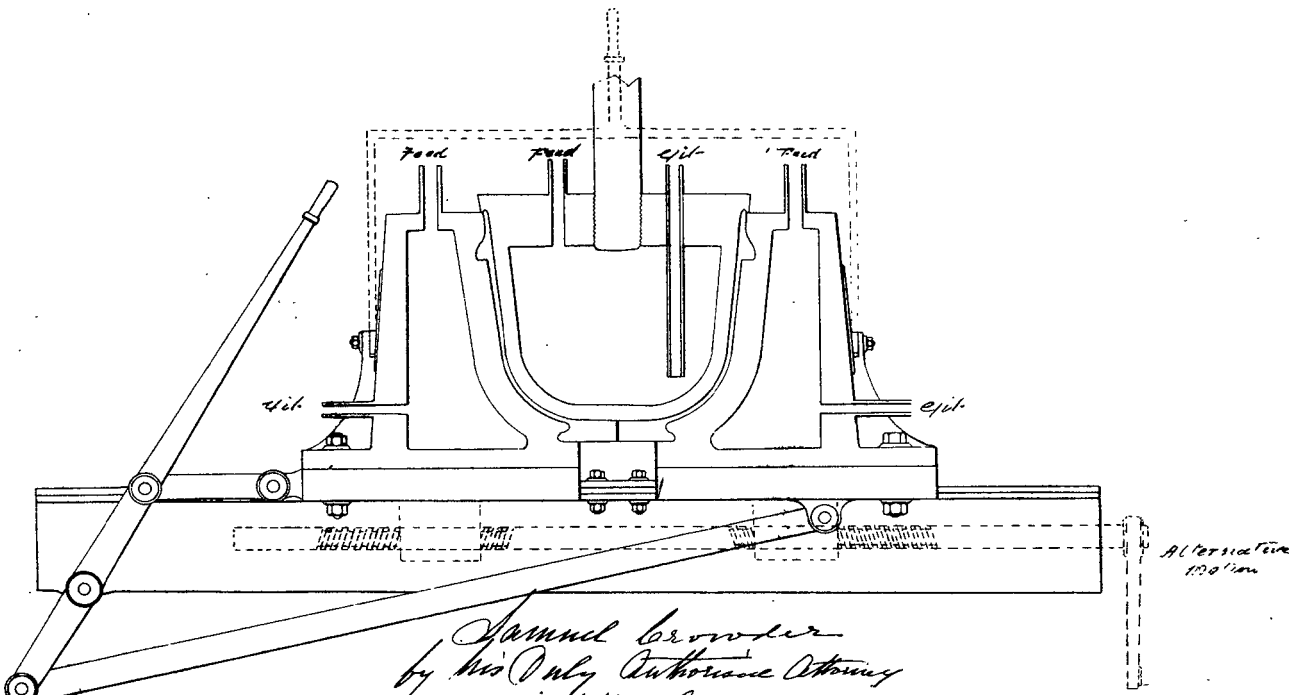
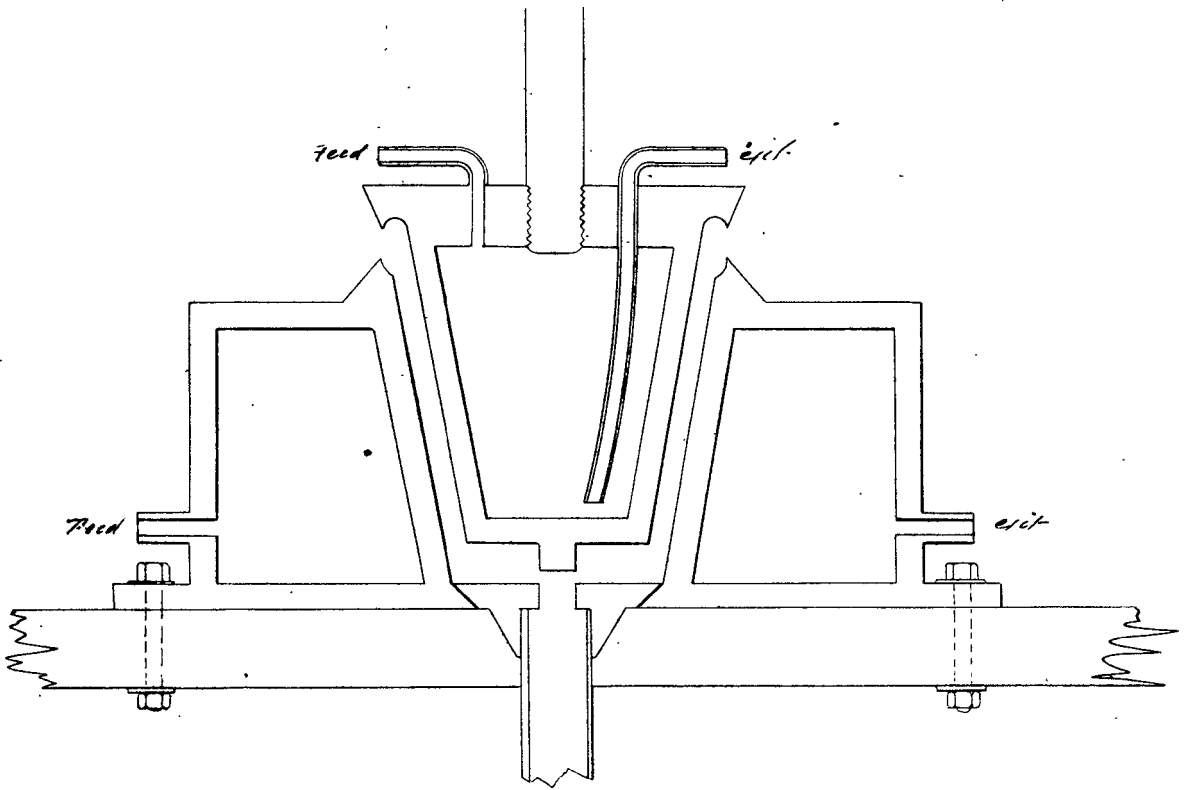
JAMES BARNET.  
WILLIAM C. BENNETT.

The Under Secretary of Justice.

—

[Drawings—one sheet.]





*Samuel Crowder  
by his Only Authorised Attorney  
W. H. Crowder*

*Witness -  
Per Sir James Spence  
Licensed Patent Agent  
London*

*This is the Sheet of Drawings referred to in the annexed  
Letters of Registration granted to Samuel Crowder, this  
thirteenth day of April, A. D. 1883.*

*Augustus Loftus.*

PHOTO-LITHOGRAPHED AT THE GOVT. PRINTING OFFICE,  
SYDNEY, NEW SOUTH WALES.

*(Sig 35.)*




---

A.D. 1883, 14th April. No. 1220.

---

IMPROVEMENTS IN WATER-WASTE PREVENTERS.

LETTERS OF REGISTRATION to William Bartholomew, for Improvements in Water-waste Preventers.

[Registered on the 14th day of April, 1883, in pursuance of the Act 16 Vic. No. 24.]

BY HIS EXCELLENCY THE RIGHT HONORABLE SIR AUGUSTUS WILLIAM FREDERICK SPENCER LOFTUS (commonly called LORD AUGUSTUS LOFTUS), Knight Grand Cross of the Most Honorable Order of the Bath, a Member of Her Majesty's Most Honorable Privy Council, Governor and Commander-in-Chief of the Colony of New South Wales and its Dependencies.

TO ALL TO WHOM THESE PRESENTS SHALL COME, greeting :

WHEREAS WILLIAM BARTHOLOMEW, of Doulton's Sanitary Engineering Works, Albert Embankment, in the County of Surrey, England, hath by his Petition humbly represented to me that he is the author or designer of a certain invention or improvement in manufactures, that is to say, of an invention entitled "Improvements in Water-waste Preventers," which is more particularly described in the specification and the sheet of drawings which are hereunto annexed; and that he, the said Petitioner, hath deposited with the Honorable the Treasurer of the said Colony of New South Wales the sum of Twenty Pounds sterling, for defraying the expense of granting these Letters of Registration, as required by the Act of Council, sixteenth Victoria, number twenty-four; and hath humbly prayed that I would be pleased to grant Letters of Registration, whereby the exclusive enjoyment and advantage of the said invention or improvement might be secured to him for a period of fourteen years: And I, being willing to give encouragement to all inventions and improvements in the arts or manufactures which may be for the public good, and having received a report favourable to the prayer of the said Petition, from competent persons appointed by me to examine and consider the matters stated therein and to report thereon for my information, am pleased, with the advice of the Executive Council, and in exercise of the power and authority given to me by the said Act of Council, to grant, and do by these Letters of Registration grant unto the said William Bartholomew, his executors, administrators, and assigns, the exclusive enjoyment and advantage of the said invention or improvement, for and during the term of fourteen years from the date hereof; to have, hold, and exercise unto the said William Bartholomew, his executors, administrators, and assigns, the exclusive enjoyment and advantage thereof, for and during and unto the full end and term of fourteen years from the date of these presents next and immediately ensuing, and fully to be complete and ended: Provided always, that if the said William Bartholomew shall not, within three days after the granting of these Letters of Registration, register the same in the proper office in the Supreme Court at Sydney, in the said Colony of New South Wales, then these Letters of Registration, and all advantages whatsoever hereby granted, shall cease and become void.

In witness whereof, I have hereunto set my sign manual, and have caused the present Letters of Registration to be sealed with the seal of the said Colony of New South Wales, at Government House, Sydney, in New South Wales, this thirteenth day of April, in the year of our Lord one thousand eight hundred and eighty-three.

[L.S.]

AUGUSTUS LOFTUS.

*Improvements in Water-waste Preventers.*

SPECIFICATION of William Bartholomew, of Doulton's Sanitary Engineering Works, Albert Embankment, in the County of Surrey, England, for an invention entitled "Improvements in Water-waste Preventers."

THIS invention has for its object improvements in water-waste preventers, and is applicable to prevent waste of water in supplying water-closets and draw-off cocks of any kind where it is desired that a certain measure of water should be delivered at each action of the apparatus, and that no more should pass until the apparatus is again started by an external impulse.

The apparatus consists of a cistern of a capacity to contain the measure of water to be delivered at one time; it is provided with a ball-cock to fill it from another cistern or from the main. An overflow may also be fitted, which, however, comes into use only if the ball-cock should get out of order. The delivery to the closet or draw-off is by a wide-mouthed funnel connected through the bottom of the cistern with the delivery pipe. This funnel has its mouth just above the water-level in the cistern, so that whilst the apparatus remains at rest no water can pass down it. Under such circumstances the cistern fills and the ball-cock closes when the water in the cistern is still below the mouth of the funnel. The funnel is covered by a bell-shaped vessel extending nearly, but not quite, to the bottom of the cistern, and the mouth of the bell is partially closed around the neck of the funnel (but still leaving an ample water-way) by an inwardly projecting flange. This bell is hung from one end of a lever having its fulcrum upon the side of the cistern and a shorter arm projecting over. A wire or pull is attached to the shorter overhanging arm of the lever, so that this may be sharply pulled down when the water should be delivered. The effect of this operation is to raise the water contained in the bell and cause it to overflow the wide mouth of the funnel on all sides. This water, flowing down into the delivery pipe, establishes a siphon-like action, and the flow once started does not stop until the cistern is empty, or nearly so. The flange at the bottom of the bell is turned up around its inner edge so that it may contain a certain amount of water, which, acting as a weight, aids the return of the bell. The flange also aids in lifting the water when the bell is drawn up.

When the apparatus is used in connection with a water-closet having a movable seat the depression of the seat may be caused to raise a weight, which, when the seat becomes free to rise, descends, and in so doing lifts the bell suddenly, and so sets up the siphon-like action.

An after-flow may be obtained by providing a receiver in connection with the delivery pipe; this receiver fills with the first rush of water, and slowly empties itself again by a small hole into the delivery pipe, so that the pan of the closet is not under any circumstances left without water.

In order that my said invention may be most fully understood and readily carried into effect, I will proceed to describe the drawings hereunto annexed.

## DESCRIPTION OF THE DRAWINGS.

Figure 1 is a vertical section of a water-waste preventer constructed according to my invention, and suitable for use to supply a water-closet.

*a a* is a measuring cistern of a capacity adapted to the discharge which it is desired to obtain; *b* is the ball-cock by which the cistern is supplied; *c* is an overflow pipe to carry off leakage in case the ball-cock should get out of order; *d* is the funnel mouth of the delivery pipe; it stands above the high-water level of the cistern; *e* is a lifting bell covering the funnel *d*; it is suspended from a lever *f*. By a wire connected at *f*<sup>1</sup> the lever is caused to lift the bell to set the apparatus in action. The bell being briskly raised carries up the water with it by suction until it overflows the funnel *d*, and the flow thus resulting down the delivery pipe sets up the siphon-like action, which empties the cistern *a*. The bell *e* is flanged inwards at *e*<sup>1</sup> so as to contract its mouth; it is thus rendered more efficient to carry the water up with it in rising. The flange *e*<sup>1</sup> also retains a certain amount of water which, when the cistern is empty, serves as a weight, and aids in bringing the bell down. Blocks are provided on which the bell rests at a short distance from the bottom of the cistern, such that the water can freely enter the bell at the bottom.

Figure 2 shows a similar arrangement, except that the bell is provided with a loosely fitted movable bottom *e*<sup>2</sup>, which has a valve-like action, lifting to admit water into the bell, but closing against the passage of water out from it. In this arrangement the funnel mouth stands above the top of the cistern as the loose bottom increases the lifting power.

Figure 3 shows the apparatus adapted to be worked automatically from the seat of a closet. The seat when depressed thrusts the rod *g* upwards, lifting the weight *f*<sup>2</sup> and depressing the bell *e*. When the seat of the closet is free to rise the weight *f*<sup>2</sup> falls, lifting the bell and causing the delivery of the water, as already described.

Figure 4 shows the apparatus with the additions which I make with a view to obtain an after-flow, or the slow discharge of a small quantity of water after the main rush is past; this after-flow will serve to fill the basin of a valve closet. It will be seen that there is a small receiver *h* beneath the bottom of the main cistern *a*, which receives and retains for a time a part of the water rushing from the cistern *a*, but it gradually runs into the delivery pipe by an aperture at *h*<sup>1</sup>. A valve may also be provided, as is shown at *i*<sup>1</sup>, attached to the bell and lifting with it. Such a valve serves to limit the main flow to the time during which the lever *f* is held up. When such a valve is provided a perforation may be formed at *d*<sup>1</sup> to admit water to the interior of *d* before the bell *e* is lifted, or the water-line may be placed above *d*.

Figure 5 shows the apparatus in a form suited for flushing drains, and to obviate the waste resulting from flushing drains by opening service cocks and other methods at present in use.

The measuring cistern *a* in this case is supplied by a slow continuous flow by a tap or otherwise. Meanwhile the bell *e* remains down, the weighted end of the lever *f* being supported by a finger *k* upon an axis *k*<sup>1</sup>. The axis *k*<sup>1</sup> carries a pinion or toothed arc gearing into a similar pinion or arc upon the axis *l*; *m* is a ball lever also fixed to the axis *l*. The ball floats up with the rise of the water, and by turning the pair of axes gradually depresses the finger *k* until the end of the lever *f* slips off from it. The weight then raises the bell; the siphon-like action is established, and the drain is effectually flushed by the sudden discharge of the whole contents of the cistern. The finger *k* is jointed, so that it offers no impediment to the end of the lever *f* passing to its upper side, which it does immediately, for the suction at once depresses the bell, and the outflow of water causes the finger to rise.

Having

---

*Improvements in Water-waste Preventers.*

---

Having thus described the nature of my said invention, and the manner of performing the same, I would have it understood that I claim as my improvements in water-waste preventers,—

First—The measuring cistern *a*, the lifting bell *e*, and the delivery pipe *d*, so combined and arranged that the bell in rising carries up water with it and sets up a flow in the pipe *d*, thereby establishing a siphon-like action, and causing the discharge of the measured quantity of water, substantially as described.

Second—My improved water-waste preventers, substantially as described and illustrated by the annexed drawings.

In witness whereof, I, the said William Bartholomew, have hereunto set my hand and seal, this eleventh day of December, 1882.

WILLIAM BARTHOLOMEW.

This is the specification referred to in the annexed Letters of Registration granted to William Bartholomew, this thirteenth day of April, A.D. 1883.

AUGUSTUS LOFTUS.

---

**REPORT.**

---

Sir,

We do ourselves the honor to report, in reply to your B.C. communication of the 29th ultimo, No. 1,675, that we are of opinion that the prayer of Mr. William Bartholomew for the registration of an invention entitled "Improvements in Water-waste Preventers" may be granted, in terms of his specification, drawing, and claim.

Sydney, 15 February, 1883.

We have, &c.,

E. O. MORIARTY.  
JOHN WHITTON.

The Under Secretary of Justice.

---

[Drawings—one sheet.]

Fig. 1

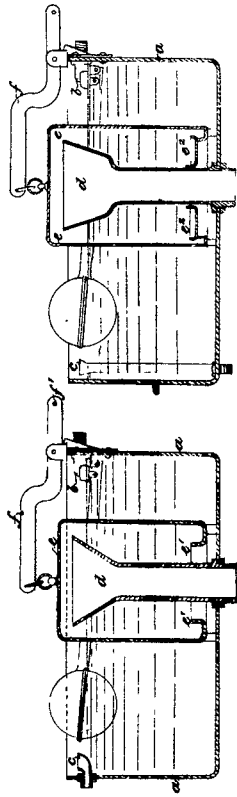


Fig. 2

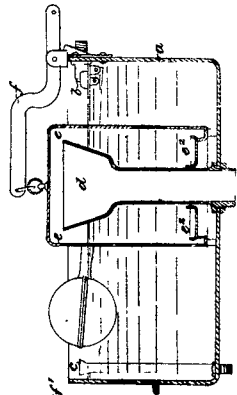


Fig. 3

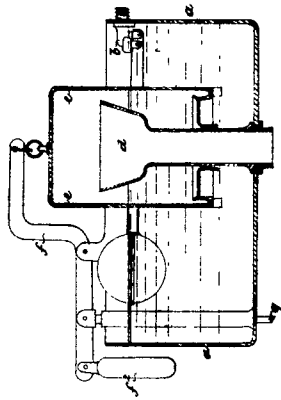


Fig. 4

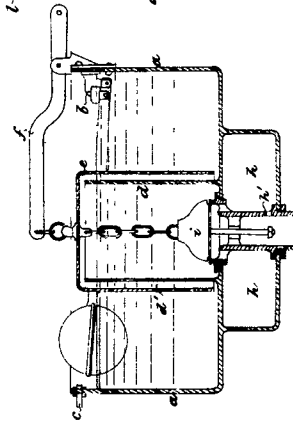
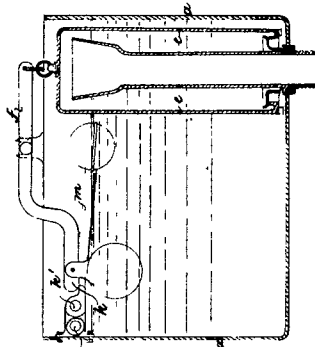


Fig. 5



*This is the Sheet of Drawings referred to in the same, red  
 Letters of Registration, granted to William Bartholomew,  
 this thirteenth day of April, A. D. 1885.  
 Augustus Loritus.*



A.D. 1883, 16th April. No. 1221.

IMPROVEMENTS IN UMBRELLAS.

LETTERS OF REGISTRATION to Henry Albert Davis, for Improvements in Umbrellas.

[Registered on the 16th day of April, 1883, in pursuance of the Act 16 Vic. No. 24.]

BY HIS EXCELLENCY THE RIGHT HONORABLE SIR AUGUSTUS WILLIAM FREDERICK SPENCER LOFTUS (commonly called LORD AUGUSTUS LOFTUS), Knight Grand Cross of the Most Honorable Order of the Bath, a Member of Her Majesty's Most Honorable Privy Council, Governor and Commander-in-Chief of the Colony of New South Wales and its Dependencies.

TO ALL TO WHOM THESE PRESENTS SHALL COME, greeting:

WHEREAS HENRY ALBERT DAVIS, of Plimsoll Road, Finsbury Park, London, in the County of Middlesex, England, hath by his Petition humbly represented to me that he is the author or designer of a certain invention or improvement in manufactures, that is to say, of an invention entitled "Improvements in Umbrellas," which is more particularly described in the specification and the sheet of drawing which are hereunto annexed; and that he, the said Petitioner, hath deposited with the Honorable the Treasurer of the said Colony of New South Wales the sum of Twenty Pounds sterling, for defraying the expense of granting these Letters of Registration, as required by the Act of Council, sixteenth Victoria, number twenty-four; and hath humbly prayed that I would be pleased to grant Letters of Registration, whereby the exclusive enjoyment and advantage of the said invention or improvement might be secured to him for a period of fourteen years: And I, being willing to give encouragement to all inventions and improvements in the arts or manufactures which may be for the public good, and having received a report favourable to the prayer of the said Petition, from competent persons appointed by me to examine and consider the matters stated therein and to report thereon for my information, am pleased, with the advice of the Executive Council, and in exercise of the power and authority given to me by the said Act of Council, to grant, and do by these Letters of Registration grant unto the said Henry Albert Davis, his executors, administrators, and assigns, the exclusive enjoyment and advantage of the said invention or improvement, for and during the term of fourteen years from the date hereof; to have, hold, and exercise unto the said Henry Albert Davis, his executors, administrators, and assigns, the exclusive enjoyment and advantage thereof, for and during and unto the full end and term of fourteen years from the date of these presents next and immediately ensuing, and fully to be complete and ended: Provided always, that if the said Henry Albert Davis shall not, within three days after the granting of these Letters of Registration, register the same in the proper office in the Supreme Court, at Sydney, in the said Colony of New South Wales, then these Letters of Registration, and all advantages whatsoever hereby granted, shall cease and become void.

In witness whereof, I have hereunto set my sign manual, and have caused the present Letters of Registration to be sealed with the seal of the said Colony of New South Wales, at Government House, Sydney, in New South Wales, this sixteenth day of April, in the year of our Lord one thousand eight hundred and eighty-three.

[L.S.]

AUGUSTUS LOFTUS.

*Improvements in Umbrellas.*

SPECIFICATION of HENRY ALBERT DAVIS, of London, England, for an invention entitled "Improvements in Umbrellas."

My invention relates to improvements in umbrellas, and is applicable to all classes of these articles, including not only those commonly so called, but also those termed sunshades and parasols.

The said invention is chiefly designed to provide more efficient means than those heretofore employed for securing the ends of the ribs to the stick, but it is also designed to improve the appearance of the umbrella by reducing its bulk at the part where the ordinary notch has heretofore been used.

The usual method of securing the ribs to the notch with wire has been found in practice to be very unsatisfactory, for the reason that upon the wire breaking the ribs are released, the cover is damaged, and the umbrella is rendered temporarily useless. Moreover, when the ordinary top-notch is used the bulk of the umbrella is greatly increased, thus giving an unsightly appearance to the same; and in order to permit a notch of small size to be used it has heretofore been found necessary to employ a very weak or thin stick or a metal tube. My invention, however, permits a stick of any size or strength to be used, there being no necessity to reduce or weaken it, or to employ a very thin stick for such purpose. The said invention also provides means for attaching the ribs in a more secure manner than heretofore, and affords great strength and durability, and at the same time gives a very neat appearance to the umbrella.

In the accompanying drawing,—

Figure 1 is an elevation of my improved rib-holder applied to the stick of an umbrella, and represents a portion of two of the ribs and the cover attached thereto.

Figure 2 is a vertical central section of the said rib-holder with the two parts of the stick and a portion of one of the ribs therein.

Figure 3 is an elevation of a modified form of the said rib-holder hereinafter described; and

Figure 4 is a transverse section of the same on line  $x x$ , figure 3.

Figures 5 and 6 represent the end portions of ribs adapted to be secured to my improved rib-holder.

Like letters indicate the same parts throughout the drawing.  $a$  is the stick of the umbrella, and  $b$  the rib-holder;  $c c$  are the ribs, and  $d$  is the silk or other covering material. The remaining parts are hereinafter described.

In carrying my invention into practice I employ, instead of the ordinary notch, the rib-holder  $b$ , which is constructed of brass or other suitable metal of tubular form, and which can be made smaller than, but should be as large in diameter as, the body of the umbrella stick to which it is to be united. This rib-holder is provided at its ends with holes or sockets,  $b^1 b^2$ , to permit the connection of the same with the umbrella stick, which is divided into two parts,  $a^1 a^2$ , as shown, each of which parts is securely fastened in one of the said sockets. The said rib-holder has in its solid portion,  $b^3$ , between the said parts  $a^1 a^2$  of the stick, a series of recesses or grooves,  $e$ , to receive the ends or end portions of the ribs  $c$ , which may be formed with knobs or cross-heads to fit and work separately within the said slots, as in ordinary ball and socket joints. I prefer, however, to connect the said ribs with the rib-holder by means of a strong wire in the ordinary manner.

The part of the rib-holder immediately below the recesses  $e$ , in which the portions of the ribs  $c$  forming their heads or ends are inserted, is made taper or sloping, to permit the said ribs when closed to lie within a space not greater in circumference than the body of the stick, for a portion of their length, as shown in figure 2. A neat appearance of the umbrella is thus ensured.

When I employ ribs that are secured independently of one another, I fit a short brass or other metal tube or ring,  $g$ , upon the aforesaid rib-holder  $b$  to retain the ends of the ribs  $c$  in place in the said holder; this tube or ring is provided with slots  $g^1$ , into which the rib ends project, and through which the same work in the opening and closing of the umbrella; the said tube or ring is held upon the rib-holder in its proper position, partly by the portions of the rib ends projecting through the slots  $g^1$ , and partly by a screw, or by a wire ring,  $h$ ; this ring is partly sunk in a groove formed in the rib-holder close to the upper end or edge of the said tube  $g$ ; this ring,  $h$ , will permit the said tube to be easily and quickly shifted or slid upon the said holder, should it become necessary in case of accident or otherwise to remove or replace one or more of the said ribs.

When the ribs are connected to the rib-holder in the ordinary manner by wire, in the event of the said wire breaking, the aforesaid tube  $g$ , if employed, will prevent the ribs escaping and damaging the cover. Each of the two parts  $a^1 a^2$ , of the stick is secured in the sockets,  $b^1 b^2$ , of the rib-holder by rivets, screws, or otherwise, the said rib-holder serving as a union or connecting piece for the said parts. Either or both of these parts or portions,  $a^1 a^2$ , of the stick, when secured to the rib-holder by screws, can be readily detached to reduce the length of the umbrella to facilitate the packing of the same in a portmanteau or for other purposes.

To permit the silk or other covering material to be readily tied or fastened to the rib-holder, I provide the latter with an annular groove,  $b^4$ , a short distance above the recesses  $e$ , in which the ends of the ribs work as shown. The said rib-holder, with the exception of the part  $b^4$ , is thus concealed by the silk or other material, and this part,  $b^4$ , greatly improves the appearance and finish of the umbrella, and takes the place of and therefore obviates the necessity of employing an "open cap" as ordinarily used.

In some cases, instead of so forming the partitions,  $b^3$ , between the recesses  $e$  that the heads or ends only of the ribs will be enclosed by the same when secured to the rib-holder, as in figures 1 and 2, I extend the said partitions in the direction of the length of the said rib-holder, as shown in figure 3, to further increase the strength of the latter.

I prefer to employ in connection with my improved rib-holder ribs of the well-known "Paragon" construction, and for this purpose form the grooves or recesses  $e$  of the same shape as the ends of the ribs, as shown in the drawing. When the projections  $b^3$  are extended, as shown in figure 3, they may be reduced in width below the ring  $g$ , as shown, so that the grooves or recesses between the projections will correspond in form with the end or upper portion of the ordinary Paragon rib shown in figure 5; or the projections may be made of one width throughout, so that the said grooves or recesses between the same will be comparatively narrow, the end portion of such ribs being flattened or closed, as shown at  $c^1$ , in figure 6, so as to fit within the said grooves or recesses.

Having

---

*Improvements in Umbrellas.*

---

Having thus described my said invention, and the manner of performing the same, I wish it understood that I claim,—

First—The improved rib-holder (with or without the slotted tube) constructed substantially as above set forth and shown in the drawings, for the purpose specified.

Second—An umbrella stick formed in two parts united by a rib-holder which has a solid portion containing recesses for the reception of the rib ends between the two parts of the stick, as above set forth.

Third—The combination of my improved rib-holder with the other parts of an umbrella, substantially as shown and described.

In witness whereof, I, the said Henry Albert Davis, have hereto set my hand and seal, this first day of December, 1882.

HENRY ALBERT DAVIS.

Witness—

J. T. KNOWLES.

---

This is the specification referred to in the annexed Letters of Registration, granted to Henry Albert Davis, this sixteenth day of April, A.D. 1883.

AUGUSTUS LOFTUS.

---

REPORT.

---

Sir,

The application of Mr. H. A. Davis for Letters of Registration for an invention entitled "Improvements in Umbrellas" having been referred to us, we have examined the plan and specification accompanying the same, and have now the honor to report that we see no objection to the issue of Letters of Registration as applied for.

Sydney, 23 February, 1883.

We have, &c.,

ARCH. FRASER.

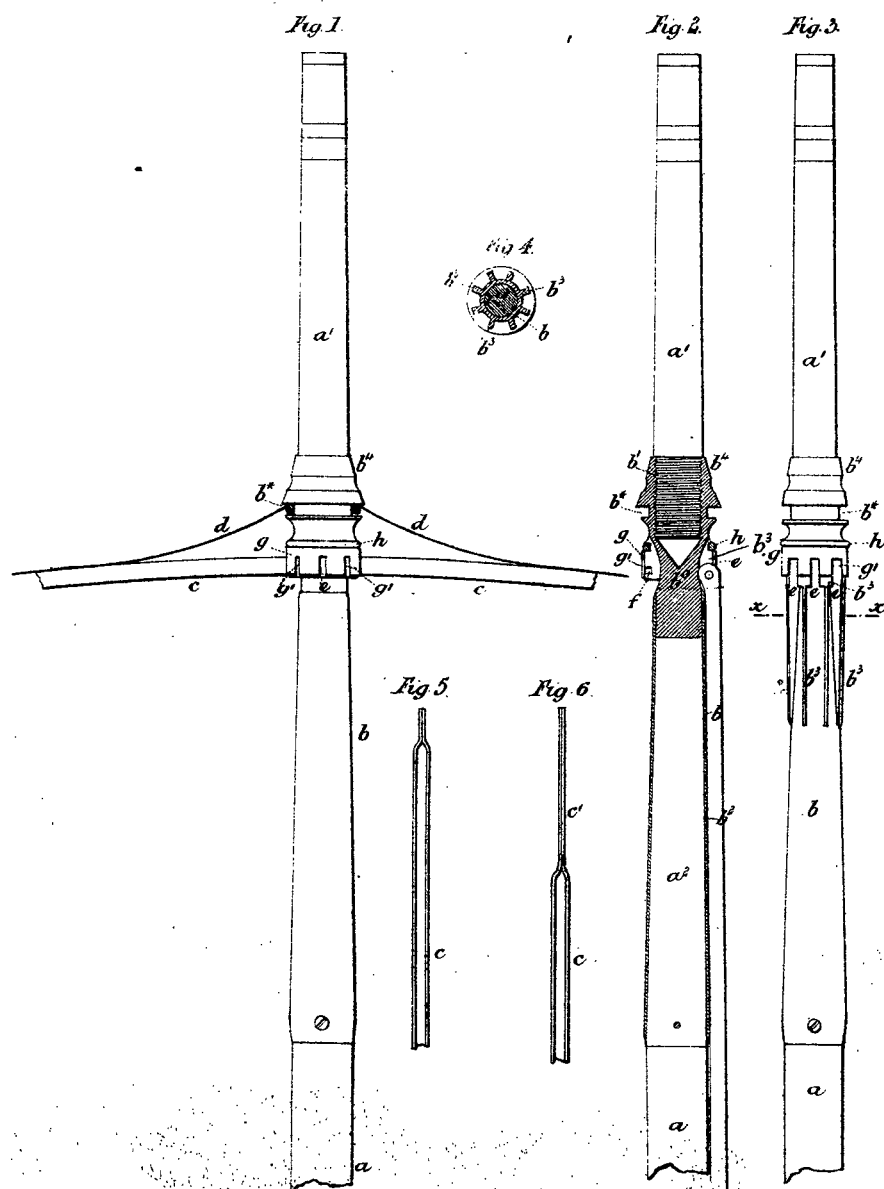
THOS. RICHARDS.

The Under Secretary of Justice.

---

[Drawings—one sheet.]





*This is the Sheet of Drawings referred to in the annexed Letters of Registration granted to Henry Albert Davis this sixteenth day of April A. D 1883.*

*(Sig. 35)*

*Augustus Loftus.*




---

A.D. 1883, 16th April. No. 1222.

---

AN IMPROVED SLIDE VALVE.

LETTERS OF REGISTRATION to Edward William Cracknell, for an Improved Slide Valve.

[Registered on the 17th day of April, 1883, in pursuance of the Act 16 Vic. No. 24.]

BY HIS EXCELLENCY THE RIGHT HONORABLE SIR AUGUSTUS WILLIAM FREDERICK SPENCER LOFTUS (commonly called LORD AUGUSTUS LOFTUS), Knight Grand Cross of the Most Honorable Order of the Bath, a Member of Her Majesty's Most Honorable Privy Council, Governor and Commander-in-Chief of the Colony of New South Wales and its Dependencies.

TO ALL TO WHOM THESE PRESENTS SHALL COME, greeting :

WHEREAS EDWARD WILLIAM CRACKNELL, of 257, George-street, Sydney, consulting engineer, hath by his Petition humbly represented to me that he is the author or designer of a certain invention or improvement in manufactures, that is to say, of an invention entitled "An Improved Slide Valve," which is more particularly described in the specification and the sheet of drawings which are hereunto annexed ; and that he, the said Petitioner, hath deposited with the Honorable the Treasurer of the said Colony of New South Wales the sum of Twenty Pounds sterling, for defraying the expense of granting these Letters of Registration, as required by the Act of Council, sixteenth Victoria, number twenty-four ; and hath humbly prayed that I would be pleased to grant Letters of Registration, whereby the exclusive enjoyment and advantage of the said invention or improvement might be secured to him for a period of fourteen years : And I, being willing to give encouragement to all inventions and improvements in the arts or manufactures which may be for the public good, and having received a report favourable to the prayer of the said Petition, from competent persons appointed by me to examine and consider the matters stated therein and to report thereon for my information, am pleased, with the advice of the Executive Council, and in exercise of the power and authority given to me by the said Act of Council, to grant, and do by these Letters of Registration grant unto the said Edward William Cracknell, his executors, administrators, and assigns, the exclusive enjoyment and advantage of the said invention or improvement, for and during the term of fourteen years from the date hereof ; to have, hold, and exercise unto the said Edward William Cracknell, his executors, administrators, and assigns, the exclusive enjoyment and advantage thereof, for and during and unto the full end and term of fourteen years from the date of these presents next and immediately ensuing, and fully to be complete and ended : Provided always, that if the said Edward William Cracknell shall not, within three days after the granting of these Letters of Registration, register the same in the proper office in the Supreme Court, at Sydney, in the said Colony of New South Wales, then these Letters of Registration, and all advantages whatsoever hereby granted, shall cease and become void.

In witness whereof, I have hereunto set my sign manual, and have caused the present Letters of Registration to be sealed with the seal of the said Colony of New South Wales, at Government House, Sydney, in New South Wales, this sixteenth day of April, in the year of our Lord one thousand eight hundred and eighty-three.

[L.S.]

AUGUSTUS LOFTUS.

*An Improved Slide Valve.*

SPECIFICATION of EDWARD WILLIAM CRACKNELL, Consulting Engineer, of 257, George-street, Sydney, for an invention entitled "An Improved Slide Valve."

It consists of a valve which slides with a circular or partly circular motion.

Figure 1 shows a plan of the face on which the valve slides.

Figure 2 shows the valve.

Figure 3, a section through valve cover, valve and face.

Figure 4 shows the plan of a valve face for admitting high or low pressure, as required.

Figure 5 shows the valve also.

Figures 1, 2, and 3 show this valve designed for regulating hydraulic or other machinery where a gradual cut-off is required.

Figure 1 shows a plan of the face on which the valve slides; C is a port or opening communicating with the lift or other machine; D is a port or opening through which the water or other fluid can be discharged or go to waste.

Figure 2 shows a plan of the valve; E is the shaft or spindle, which can also be seen in figure 3; F is a cavity or passage through which the water or other fluid can pass from the lift or other machine to waste.

Figure 3 shows a section through the valve, valve cover, and valve face; G is the inlet; C the port communicating with the ram; D is the outlet; H is a shaft keyed or fixed to the valve. The action of this valve is as follows:—A circular motion is imparted to the slide valve by turning the shaft H, which causes it to slide over the ports C and D; this valve is designed for regulating hydraulic or other machinery where a gradual cut-off is required. In order to prevent any shock to pipes or machinery, for this reason the port C and exhaust cavity F are made semi-circular; where a quick or decisive cut-off is required the shape of the ports can be altered. The back of the valve or spindle E is enlarged to balance or counteract the pressure on the valve face. If the valve is to be used for a low pressure the back may be reduced in size; if for a very high pressure it should be very nearly equal in area to the back of the valve.

Figures 4, 5, and 6 show one of these valves designed for admitting high or low pressure for working hydraulic presses or other machinery where it is necessary to have two pressures.

Figure 4 shows a plan of the face on which the valve slides or opening through which the water or other fluid can be discharged or go to waste; *g* is the inlet for the low-pressure fluid.

Figure 5 shows a valve; *e* is the shaft or spindle, which can also be seen in figure 6; *f* is a cavity or passage through which the water or other fluid can pass from the press or other machine to waste; *l* is a cam or projection which raises or opens the valve.

Figure 6 shows a section through this valve, valve cover, and valve face. *d* is the outlet; *g* the inlet for low pressure; *i* is the inlet for high-pressure fluid; *j* is the high-pressure valve; *h* is the shaft or spindle; *k* a spring.

The action of this form of valve is as follows:—Motion is imparted to the valve by turning the shaft *h*, which causes it to slide over the ports *c*, *d*, and *g*. When the slide valve is turned far enough to cover the low-pressure inlet *g*, the cam or projection *l* raises or opens the high-pressure valve *j*, thus admitting high-pressure water to the press or other machine. The back of the valve or spindle *e* is enlarged to counteract the pressure on the valve face. The spring *k* is used to prevent the valve from lifting off the face when the pressures are changing.

I claim—

First.—That this valve can be used for any fluid, gas, air, or vapour, for the purpose set forth.

Second.—That any number of ports may be made in the valve face, and such ports as shown on drawing, or of any required shape, so as to ensure a decisive or a gradual cut-off or entry.

Third.—That the valve may be designed to work by a complete or only partial revolution.

Fourth.—That the valve may be wholly or partially balanced by increasing or diminishing the size of the back balance, as described.

Fifth.—The spring to assist in keeping the valve on the face or to prevent undue pressure.

Sixth.—That by bringing the spindle through both cover and valve face, where required, it is capable of being worked from either side.

Given under my hand and seal, this thirteenth day of January, one thousand eight hundred and eighty-three.

E. W. CRACKNELL.

This is the Specification referred to in the annexed Letters of Registration granted to Edward William Cracknell, this sixteenth day of April, A.D. 1883.

AUGUSTUS LOFTUS.

### REPORTS.

Sir,

Sydney, 23 January, 1883.

We do ourselves the honor to report, in reply to your blank-cover communication of the 15th instant, No. 930, transmitting Mr. Edward William Cracknell's Petition for the registration of an invention entitled "An Improved Slide Valve," that there is apparently sufficient novelty in the invention to justify the recommendation of the prayer of the Petition, but that the description accompanying it is too inexplicit for registration. We therefore suggest that Mr. Cracknell should be requested to revise his specification and drawing by the introduction of letters of reference to the various parts and arrangements described and shown in plan or section, the like letters or marks being retained throughout to indicate like parts.

We have, &c.,

E. O. MORIARTY.

GOTHER K. MANN.

The Under Secretary of Justice.

Sydney,

---

*An Improved Slide Valve.*

---

Sir,

Sydney, 22 February, 1883.

In reply to your blank cover of the 15th instant, No. 2,678, transmitting Mr. E. W. Cracknell's revised specification, drawing, and claim for the registration of an invention entitled "An Improved Slide Valve," we do ourselves the honor to report that we are of opinion the prayer of Mr. Cracknell's Petition may now be granted.

We have, &c.,

E. O. MORIARTY.  
GOTHER K. MANN.

The Under Secretary of Justice.

---

[Drawings—one sheet.]

---

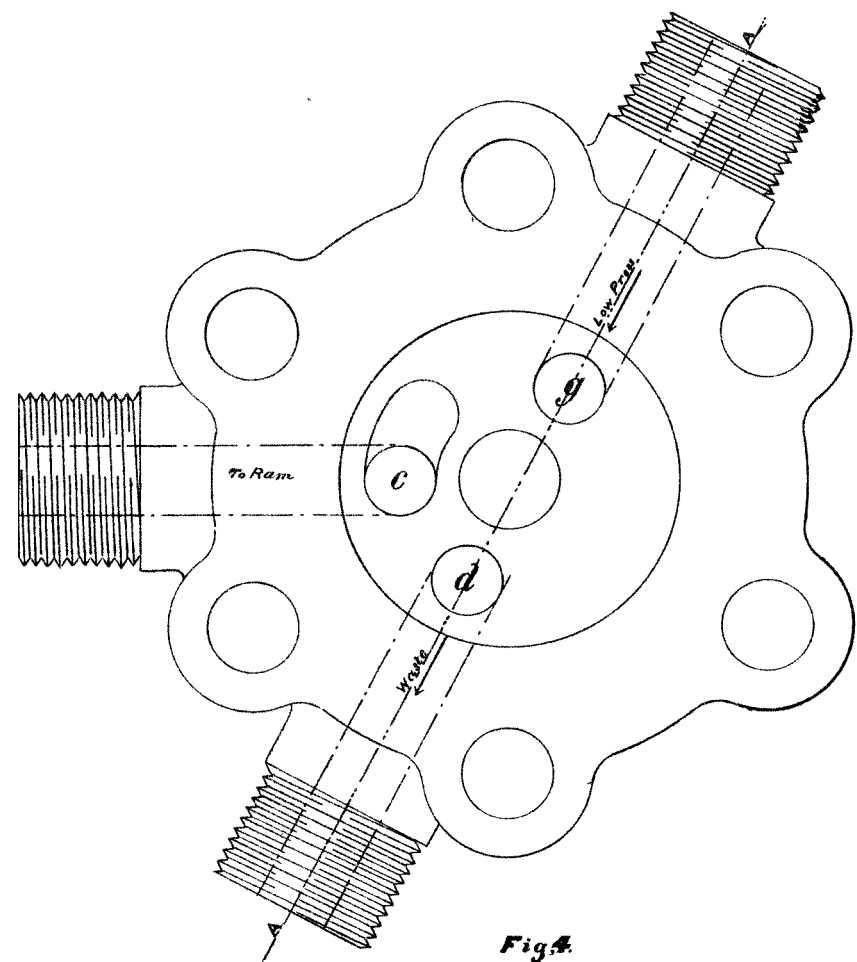
**No. 1223.**

[Assignment of No. 1114. See Letters of Registration for 1882, page 303.]

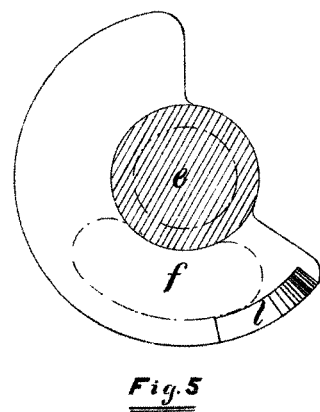
---

**No. 1224.**

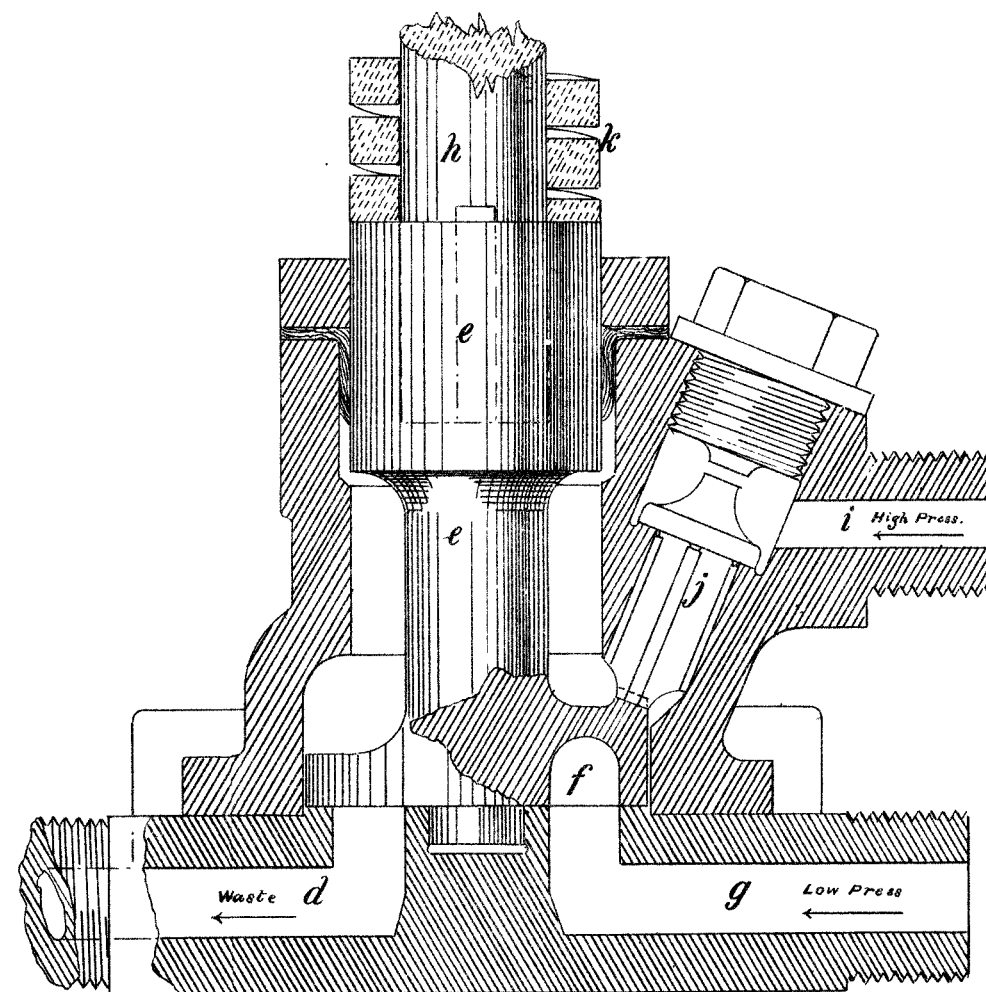
[Assignment of No. 1187. See Letters of Registration for 1883, page 45.]



**Fig. 1.**

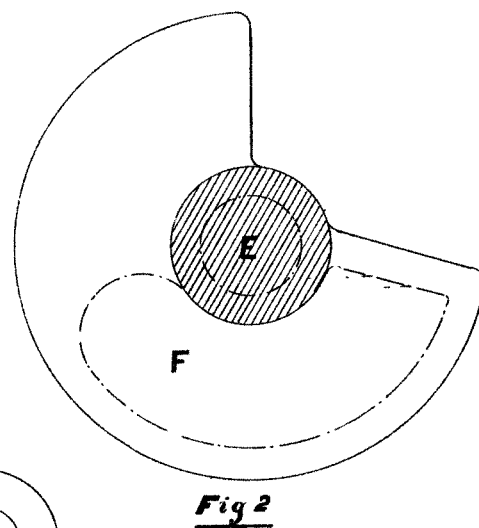


**Fig. 5.**

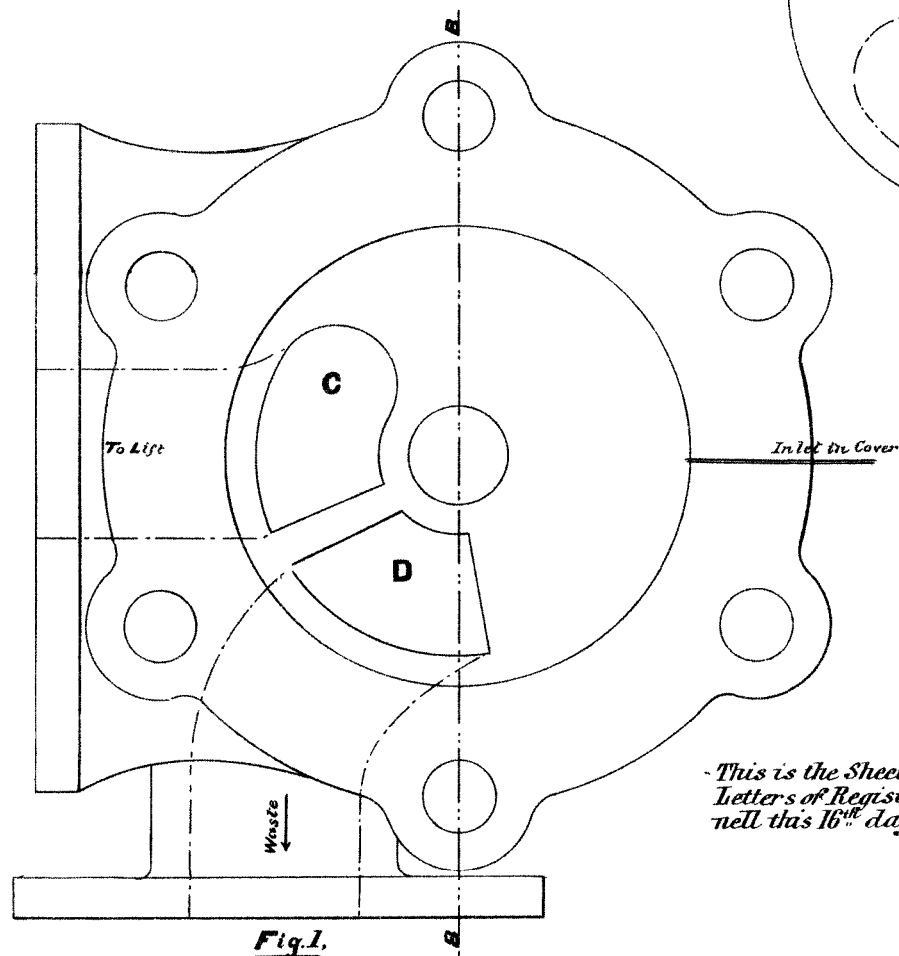


**SECTION A.**  
**Fig. 6.**

*E. W. Cracknell*  
*Jan. 13<sup>th</sup> 1883*

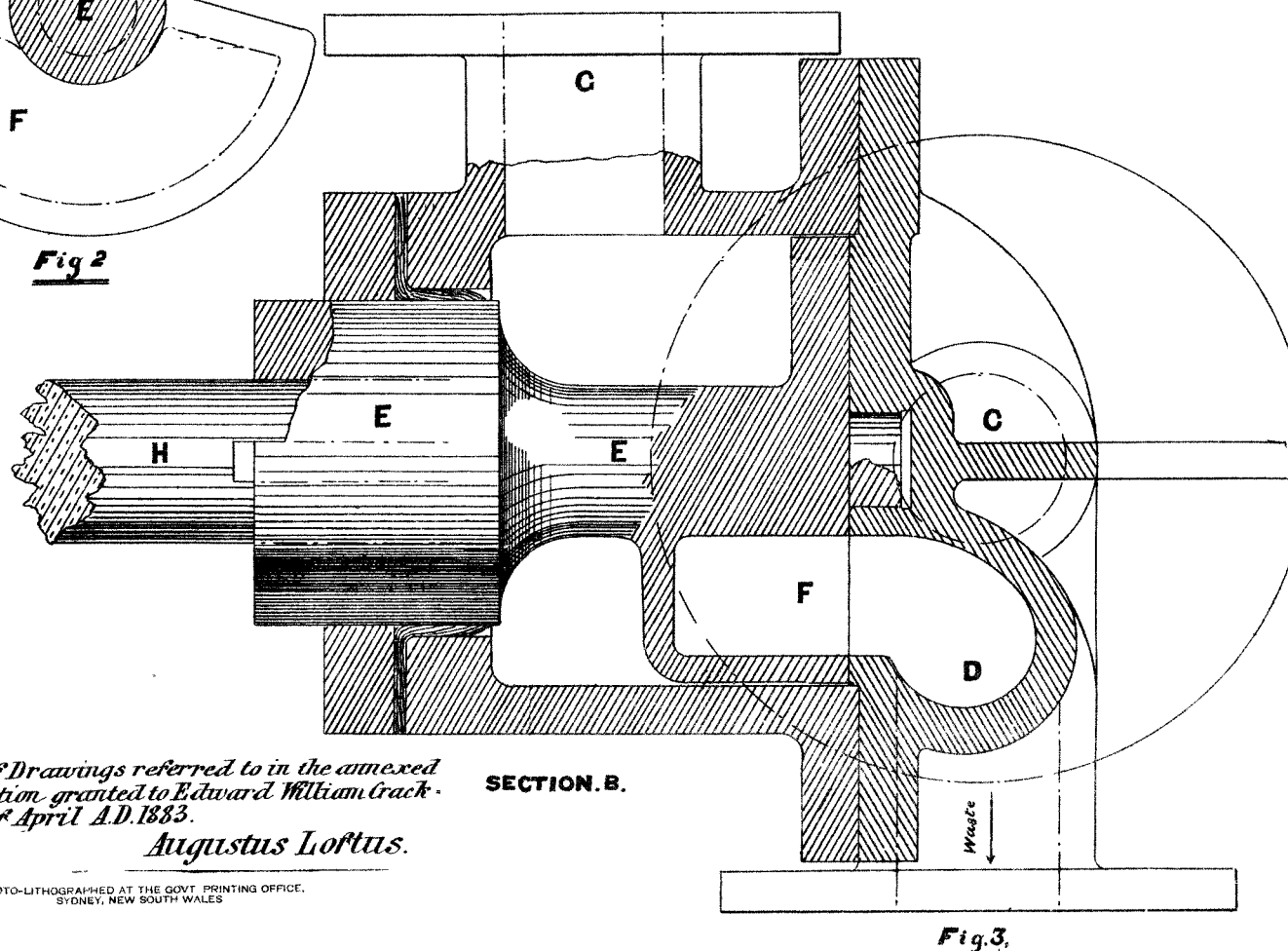


**Fig. 2.**



**Fig. 1.**

(Sig. 3.1.)



**SECTION B.**

**Fig. 3.**

*This is the Sheet of Drawings referred to in the annexed Letters of Registration granted to Edward William Cracknell this 16<sup>th</sup> day of April A.D. 1883.*  
*Augustus Loftus.*




---

A.D. 1883, 20th April. No. 1225.

---

THE OPEN-TOP FUEL-DISTRIBUTING KILN.

LETTERS OF REGISTRATION to James Kay, William Aspinall, and Bernard Rafferty, for an invention entitled "The Open-top Fuel-distributing Kiln."

[Registered on the 20th day of April, 1883, in pursuance of the Act 16 Vic. No. 24.]

BY HIS EXCELLENCY THE RIGHT HONORABLE SIR AUGUSTUS WILLIAM FREDERICK SPENCER LOFTUS (commonly called LORD AUGUSTUS LOFTUS), Knight Grand Cross of the Most Honorable Order of the Bath, a Member of Her Majesty's Most Honorable Privy Council, Governor and Commander-in-Chief of the Colony of New South Wales and its Dependencies.

TO ALL TO WHOM THESE PRESENTS SHALL COME, greeting:

WHEREAS JAMES KAY, WILLIAM ASPINALL, and BERNARD RAFFERTY, all of the Cook's River Road, near Sydney, brickmakers, have by their Petition humbly represented to me that they are the authors or designers of a certain invention or improvement in manufactures, that is to say, of an invention entitled "The Open-top Fuel-distributing Kiln," which is more particularly described in the specification and the sheet of drawings which are hereunto annexed; and that they, the said Petitioners, have deposited with the Honorable the Treasurer of the said Colony of New South Wales the sum of Twenty Pounds sterling, for defraying the expense of granting these Letters of Registration, as required by the Act of Council, sixteenth Victoria, number twenty-four; and have humbly prayed that I would be pleased to grant Letters of Registration, whereby the exclusive enjoyment and advantage of the said invention or improvement might be secured to them for a period of fourteen years: And I, being willing to give encouragement to all inventions and improvements in the arts or manufactures which may be for the public good, and having received a report favourable to the prayer of the said Petition, from competent persons appointed by me to examine and consider the matters stated therein and to report thereon for my information, am pleased, with the advice of the Executive Council, and in exercise of the power and authority given to me by the said Act of Council, to grant, and do by these Letters of Registration grant unto the said James Kay, William Aspinall, and Bernard Rafferty, their executors, administrators, and assigns, the exclusive enjoyment and advantage of the said invention or improvement for and during the term of fourteen years from the date hereof; to have, hold, and exercise unto the said James Kay, William Aspinall, and Bernard Rafferty, their executors, administrators, and assigns, the exclusive enjoyment and advantage thereof for and during and unto the full end and term of fourteen years from the date of these presents next and immediately ensuing, and fully to be complete and ended: Provided always, that if the said James Kay, William Aspinall, and Bernard Rafferty shall not, within three days after the granting of these Letters of Registration, register the same in the proper office in the Supreme Court, at Sydney, in the said Colony of New South Wales, then these Letters of Registration, and all advantages whatsoever hereby granted, shall cease and become void.

In witness whereof, I have hereunto set my sign manual, and have caused the present Letters of Registration to be sealed with the seal of the said Colony of New South Wales, at Government House, Sydney, in New South Wales, this twentieth day of April, in the year of our Lord one thousand eight hundred and eighty-three.

[L.S.]

AUGUSTUS LOFTUS.

*The Open-top Fuel-distributing Kiln.*

In the matter of the Petition of Messrs. Kay, Aspinall, and Rafferty, for Letters of Registration of an invention called "The Open-top Fuel-distributing Kiln."

## SPECIFICATION REFERRED TO.

1. Our invention consists of a series of kilns, or sections of kilns, arranged between two walls of brick or other material, either in a straight line, as figure 1 on plan, or annular and continuous, as in figure 2 on plan, above or below ground, or partly sunken. The bricks or other material to be burnt are placed between these walls and fired in sections in such a manner that the fire from the first section will pass through one or more succeeding sections before entering the chimney, thereby drying the unburnt bricks, burning all the smoke, and saving a great amount of fuel.

The firing.

The fuel at the commencement to be fed in through the bottom of a temporary wall or wicket until the bricks or other material are sufficiently hot to commence firing from the top, or until the first section has been burnt; then the temporary wall or wicket may be pulled down to allow a greater draught to circulate through from section to section; the firing being now fed from the top, as soon as the first section has been sufficiently fired, the fuel may be fed into the second, and from that to the third, and so on continuously.

Setting.

The setting of the bricks to be burnt is so arranged that the fuel may be fed from the top, and a draught continued from section to section, as shown in figure 3 on plan. The setting is also arranged in case coal or slack may be used, so that the fuel fed from the top may fall down obliquely as well as vertically, thereby being distributed throughout the interior of the kiln; one or more courses being set close together at the top, and daubed or plastered, circular holes being left in these courses for the firing, thereby doing away with the permanent arch used in other continuous kilns.

Chimney.

The chimneys may be either fixed or movable; if movable they may be made of sheet iron or other suitable material, and two are then required to be placed on the top of the last section that is being heated by the fire, and moved forward from section to section as the fire proceeds. If the chimneys are permanent each section must be connected with them by means of a flue, to be left in the setting, which may be closed by a damper placed in each chimney independently of each section.

Flues continued.

The flues may also be arranged outside the kiln wall so that the second or third or any other section may be opened for the draught while the flues from the intermediate sections are closed, thereby allowing the heat from the fire to pass through these intermediate sections.

To test the amount of burning done.

The state of the burning bricks or other material is ascertained by means of a string or straight edge stretched over the upper surface of the outer walls, flush with the bricks when first put in; and by measuring the distance the bricks have shrunk below the string or straight edge the amount of burning done may be detected with accuracy.

We claim for our invention the following:—

- 1st. That the kiln is open-topped, and may be used as a continuous kiln, or otherwise.
- 2nd. The mode of setting, whereby the fuel is distributed over the whole of the interior of the kiln, in novel manner as shown in plan.
- 3rd. A temporary wall or wicket at the commencement, with space left for firing at the bottom, that may be pulled down when the firing is begun from the top.
- 4th. The small cost of the kiln, in comparison with other kilns, that brings it within the reach of small brick-masters, as well as the largest.
- 5th. Great saving of fuel.
- 6th. Burns its own smoke.
- 7th. The means of detecting the state of the burning bricks at any stage by measuring the distance the bricks have shrunk.

JAMES KAY.  
WILLIAM ASPINALL.  
BERNARD RAFFERTY.

This is the specification referred to in the annexed Letters of Registration granted to James Kay, William Aspinall, and Bernard Rafferty, this twentieth day of April, A.D. 1883.

AUGUSTUS LOFTUS.

## REPORT.

Sir,

In reference to the accompanying petition of Messrs. James Kay, William Aspinall, and Bernard Rafferty, for Letters of Registration for an invention entitled "The Open-top Fuel-distributing Kiln," we have the honor to report that although there are some points of resemblance in the invention to that of Mr. Friedrich Hoffman, which has been already patented, that there is yet sufficient dissimilarity between them to warrant our recommending a compliance with the prayer of the Petition for Letters of Registration.

We have, &c.,

E. O. MÓRIARTY.  
JOHN WHITTON.

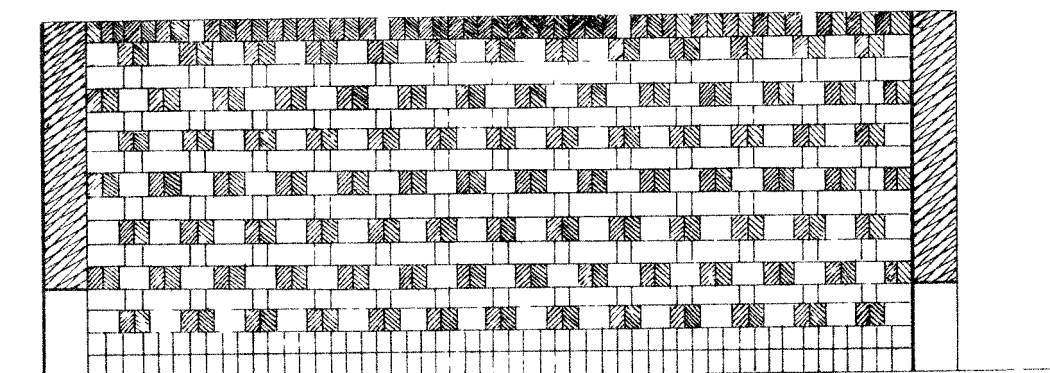
The Under Secretary of Justice.

In the matter of the Petition of Messers Kay Aspinall and Rafferty for Letters of Registration of an Invention called "The open top fuel distributing kiln"

The Plan and Drawing referred to  
James Kay  
William Aspinall } Bernard Rafferty

# MESS<sup>RS</sup> KAY, ASPINALL AND RAFERTYS

## PATENT CONTINUOUS KILN



SECTION A - B.

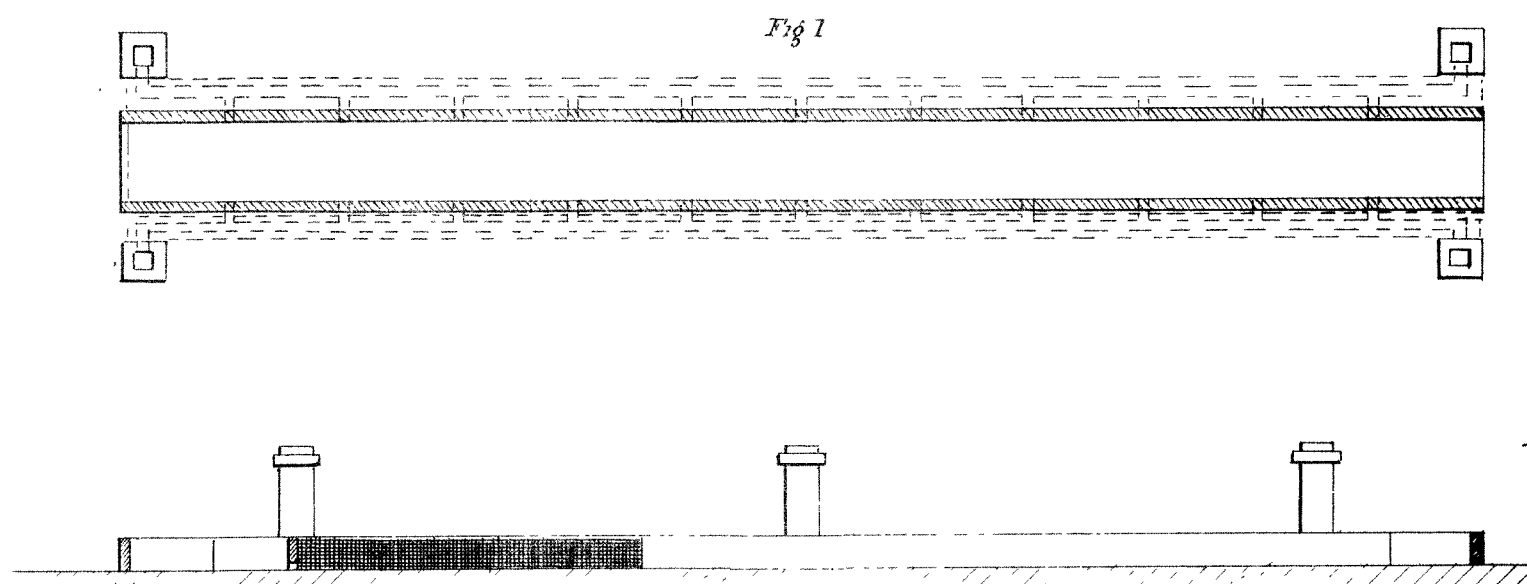
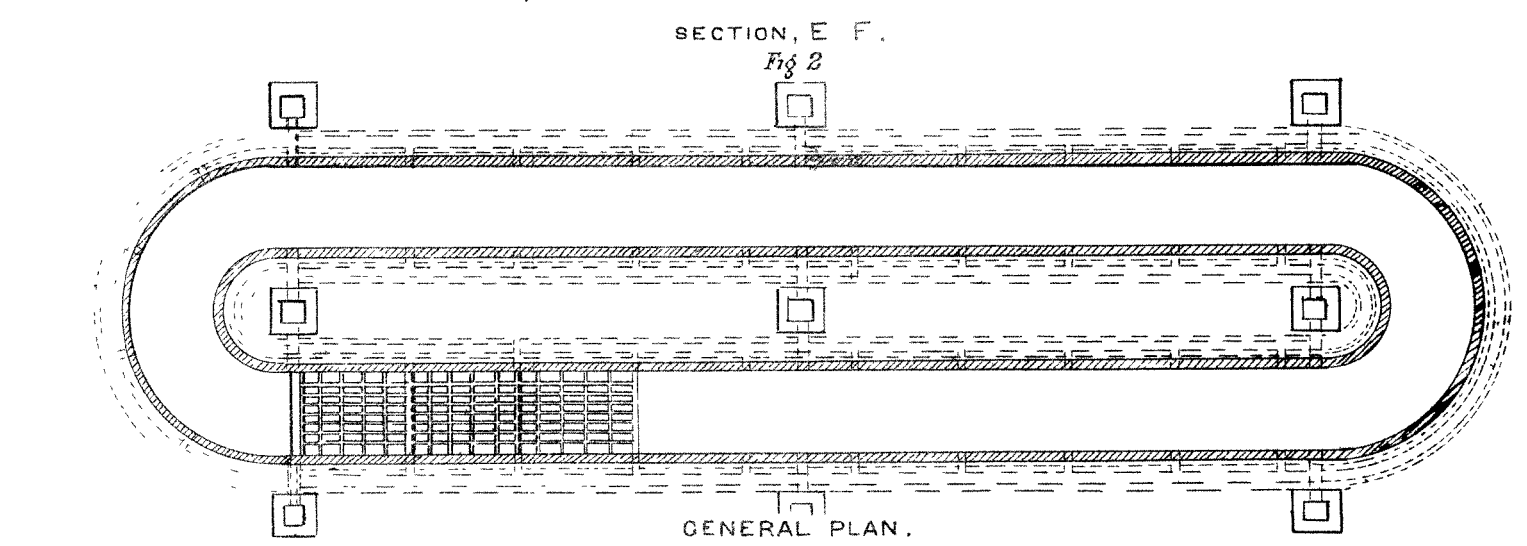


Fig 1



SECTION, E F.

Fig 2

GENERAL PLAN.

Scale 20 feet to an Inch

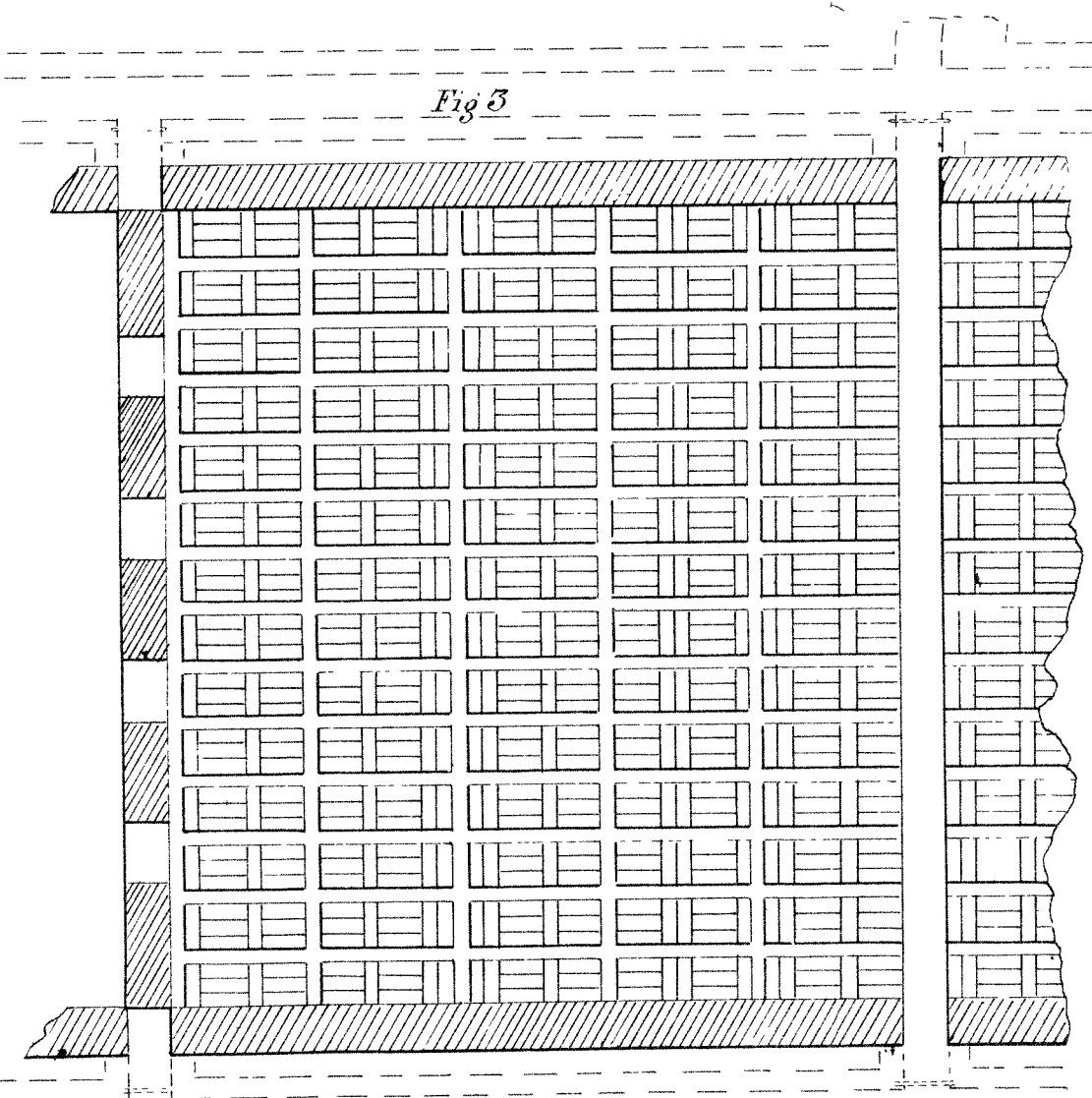


Fig 3

PLAN OF ONE SECTION.

Scale 1/2 an inch to a foot

This is the Sheet of Drawings referred to in the annexed letters of Registration granted to James Kay William Aspinall and Bernard Rafferty this twentieth day of April A. D. 1883.  
Augustus Loftus.



PARROTT & ROBERTS  
CIVIL ENGINEERS

(Sig. 3.5.)





A.D. 1883, 21st April. No. 1226.

IMPROVEMENTS IN HYDRAULIC-PRESSING MACHINERY.

LETTERS OF REGISTRATION to Norman Selfe, for Improvements in Hydraulic-pressing Machinery.

[Registered on the 23rd day of April, 1883, in pursuance of the Act 16 Vic. No. 24.]

BY HIS EXCELLENCY THE RIGHT HONORABLE SIR AUGUSTUS WILLIAM FREDERICK SPENCER LOFTUS (commonly called LORD AUGUSTUS LOFTUS), Knight Grand Cross of the Most Honorable Order of the Bath, a Member of Her Majesty's Most Honorable Privy Council, Governor and Commander-in-Chief of the Colony of New South Wales and its Dependencies.

TO ALL TO WHOM THESE PRESENTS SHALL COME, greeting:

WHEREAS NORMAN SELFE, of No. 141, Pitt-street, in the City of Sydney, and Colony of New South Wales, consulting engineer, hath by his Petition humbly represented to me that he is the author or designer of a certain invention or improvement in manufactures, that is to say, of an invention entitled "Improvements in Hydraulic pressing Machinery," which is more particularly described in the specification and the sheet of drawings which are hereunto annexed; and that he, the said Petitioner, hath deposited with the Honorable the Treasurer of the said Colony of New South Wales, the sum of Twenty Pounds sterling, for defraying the expense of granting these Letters of Registration, as required by the Act of Council, sixteenth Victoria, number twenty-four, and hath humbly prayed that I would be pleased to grant Letters of Registration, whereby the exclusive enjoyment and advantage of the said invention or improvement might be secured to him for a period of fourteen years: And I, being willing to give encouragement to all inventions and improvements in the arts or manufactures which may be for the public good, and having received a report favourable to the prayer of the said Petition, from competent persons appointed by me to examine and consider the matters stated therein and to report thereon for my information, am pleased, with the advice of the Executive Council, and in exercise of the power and authority given to me by the said Act of Council, to grant, and do by these Letters of Registration grant unto the said Norman Selfe, his executors, administrators, and assigns, the exclusive enjoyment and advantage of the said invention or improvement, for and during the term of fourteen years from the date hereof; to have, hold, and exercise unto the said Norman Selfe, his executors, administrators, and assigns, the exclusive enjoyment and advantage thereof for and during and unto the full end and term of fourteen years from the date of these presents next and immediately ensuing, and fully to be complete and ended: Provided always, that if the said Norman Selfe shall not within three days after the granting of these Letters of Registration, register the same in the proper office in the Supreme Court, at Sydney, in the said Colony of New South Wales, then these Letters of Registration, and all advantages whatsoever hereby granted, shall cease and become void.

In witness whereof, I have hereunto set my sign manual, and have caused the present Letters of Registration to be sealed with the seal of the said Colony of New South Wales, at Government House, Sydney, in New South Wales, this twenty-first day of April, in the year of our Lord one thousand eight hundred and eighty-three.

[L.s.]

AUGUSTUS LOFTUS.

*Improvements in Hydraulic-pressing Machinery.*

SPECIFICATION of Norman Selve, of No. 141, Pitt-street, in the City of Sydney, and Colony of New South Wales, consulting engineer, for an invention entitled "Improvements in Hydraulic-pressing Machinery."

THIS invention relates to certain improvements in hydraulic-pressing machinery, and has reference more particularly to machines which are used for pressing wool and such like merchandise.

These improvements consist, first and mainly, in supplying water at different pressures and in separate mains to the ram or piston of such machines; secondly, in arranging two or more pressing machines in series and connecting them to the same lines of piping for supplying the water at different pressures; and (thirdly) in regulating the admission and cut-off so that each machine is independent of the others; and (fourthly) in controlling the speed of the water-supplying engine by means of the pressure in the main or piping.

By this invention a series of wool-pressing machines may be supplied with pressure from the same sources; and by having two mains—one supplying water at relatively low pressure (say 700 pounds per square inch), and the other supplying the water at a higher pressure (say 3 tons per square inch),—the former will easily do the light work, while the latter can be put into operation to accomplish the heavy portion of the work, or final pressing of the bale.

In order that my invention may be clearly understood, and to enable others to put the same into operation, I will now describe the same with reference to my drawing, wherein similar letters indicate similar parts wherever they occur.

Figures 1 and 2 show elevation (partly in section) and plan respectively of my regulating valve; while figure 3 is a view of the same with connections from the mains to a wool-press; and figure 4 is a side-view of portion of figure 3. A is the relatively high-pressure main—A<sup>1</sup> pipe therefrom leading to regulating valve to which it is secured at A<sup>2</sup>; A<sup>3</sup> is a check valve; and A<sup>4</sup> a stop valve which is opened or closed by handle A<sup>5</sup>; B is the lower-pressure water-main—B<sup>1</sup> pipe therefrom meeting regulating valve at B<sup>2</sup>; B<sup>3</sup> is a check valve, and B<sup>4</sup> stop valve, having handle B<sup>5</sup>; C is a main for carrying off the "waste" water—C<sup>1</sup> pipe thereto from the regulating valve; C<sup>2</sup> is handle for opening stop valve, C<sup>3</sup>, of this pipe; D is pipe, screwed to socket D<sup>1</sup>, and leading to the interior of the ram cylinder, as is well understood.

Figures 5 and 6 show respectively front and side views of my governor, attached to the throttle valve of a steam-pump; A<sup>6</sup> is a pipe from any convenient part of the main A; E is a cylinder having a piston whose rod, E<sup>1</sup>, is attached to lever F. From this lever hangs rod F<sup>1</sup>, carrying weights F<sup>2</sup> and spring F<sup>3</sup>; G is a piston throttle valve connected by rod G<sup>1</sup> and lever G<sup>2</sup> to spindle F<sup>4</sup>, to which lever F is also connected by rod and lever F<sup>5</sup>; G<sup>3</sup> is the steam-supply pipe of the pump, and G<sup>4</sup> a stop valve. In operation this governor works as follows:—The weights F<sup>2</sup> and spring F<sup>3</sup> are regulated, as is easily understood, so as to give a certain maximum pressure in the main. When the pressure in the main increases the piston in cylinder E lifts lever F, and the piston of the throttle valve G, giving the pump more steam, and so the pump retains its speed or power, no matter what pressure it has to contend against. A reduction of the pressure in the main will likewise cause the weights to pull lever F down and reduce the steam opening to the pumping-engine cylinder, and a breakage of the pipes would close the throttle valve, and so stop the pump.

In practice, I have two or more pumps, one or more supplying relatively low-pressure water to an accumulator loaded to any constant pressure, and having any well-known means of regulating the supply of water to replace that used by the ram. The other pump or pumps supply its or their water into a main or mains, and have their speed regulated preferably by governors, such as those described with reference to figures 5 and 6. The first-mentioned (or low-pressure) pumps may be of any kind so long as they are able to start from any position as soon as steam is admitted to the cylinder. The other (or high-pressure) pumps must have the same characteristic, and I prefer to use a direct-acting pump without a fly-wheel, and of the form known as the "Blake" pump. The main or mains from the accumulator carrying the relatively low pressure correspond to that marked B, while those carrying the higher pressures correspond to that marked A; should there be two or more of this latter the pipe A<sup>1</sup> is interchangeably connected to all, so that either may be used as desired. These mains, and for convenience another (C) to carry away the waste water, are led throughout a warehouse or other buildings and connected to presses at desired intervals in a similar manner to that illustrated in figures 3 and 4. For the light work required when commencing to press (all the valves being closed) it is only necessary to turn handle B<sup>5</sup> to open valve B<sup>4</sup>, when the press will operate with a force due to the pressure in the accumulator. To take this pressure off again valve B<sup>4</sup> must be closed and valve C<sup>3</sup> opened, when the water from the ram cylinder will return to "waste." To use the higher-pressure valves C<sup>3</sup> and B<sup>4</sup> are closed and A<sup>4</sup> opened, and to release it A<sup>4</sup> is closed and C<sup>3</sup> opened. The check valves A<sup>3</sup> and B<sup>3</sup> prevent any loss of pressure and the descent of the press ram, which would otherwise result from the return of the water by any other than the proper passage.

Having thus particularly described and ascertained the nature of my said invention, and in what manner the same is to be performed, I would have it understood that what I believe to be novel and original, and therefore claim as my improvements in hydraulic-pressing machinery, is—

First.—Supplying water at different pressures from separate mains to the ram or piston, so that relatively low-pressure water may be used to do light work, while water at higher pressures is at hand for heavy work, substantially as herein described and explained.

Second.—Connecting two or more machines to such separate mains in series, substantially as herein described and explained.

Third.—The novel construction of regulating valve for the admission and cut-off of water at different pressures, substantially as herein described and explained, and as illustrated in figures 1 and 2 of my drawing.

Fourth.—The combination with a valve in the steam-supply pipe to a pumping engine of a governor actuated by the pressure of water in the delivery pipe or hydraulic main so that the supply of steam to the engine cylinder is controlled thereby, substantially as herein described and explained.

Fifth.—The combination and arrangement of mechanical parts as herein described and explained, and as illustrated in figures 5 and 6 of my drawing.

In

---

*Improvements in Hydraulic-pressing Machinery.*

---

In witness whereof, I, the said Norman Selfe, have hereto set my hand and seal, this twenty-third day of January, one thousand eight hundred and eighty-three.

Witness—

FRED. WALSH, Manager,  
EDWD. WATERS, Patent Office, Sydney.

NORMAN SELFE.

This is the specification referred to in the annexed Letters of Registration granted to Norman Selfe, this twenty-first day of April, A.D. 1883.

AUGUSTUS LOFTUS.

---

**REPORT.**

---

Sir,

We do ourselves the honor to report, in reply to your B.C. communication of the 22nd ultimo, No. 1,340, that we are of opinion that the prayer of Mr. Norman Selfe for the registration of an invention entitled "Improvements in Hydraulic-pressing Machinery," may be granted in terms of his specification, drawings, and claim.

Sydney, 26 February, 1883.

We have, &c.,

E. O. MORIARTY,  
JOHN WHITTON.

The Under Secretary of Justice.

---

[Drawings—one sheet.]

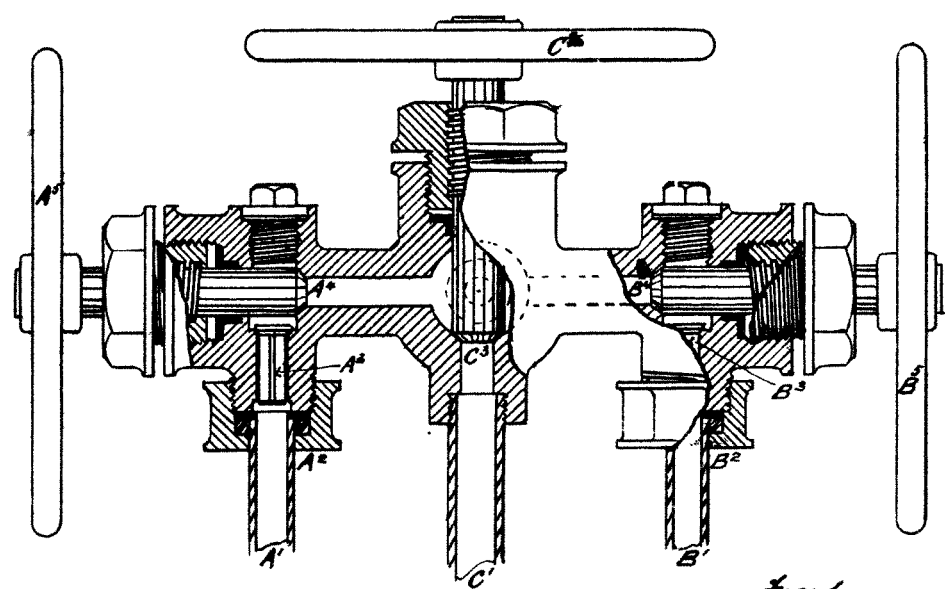


Fig. 1.

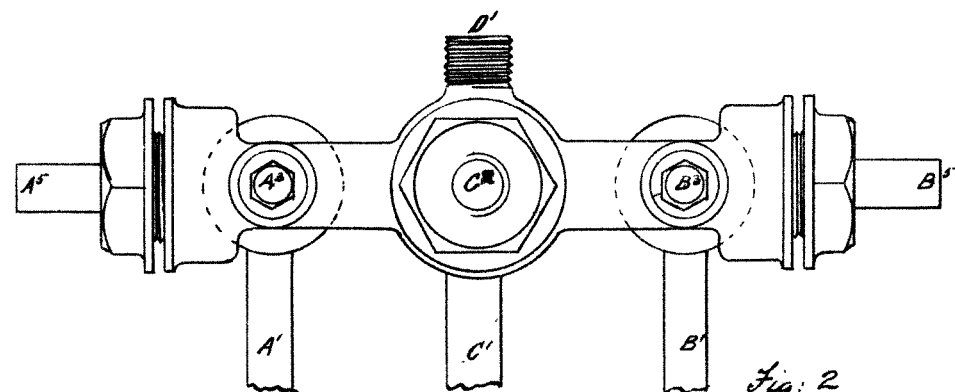


Fig. 2.

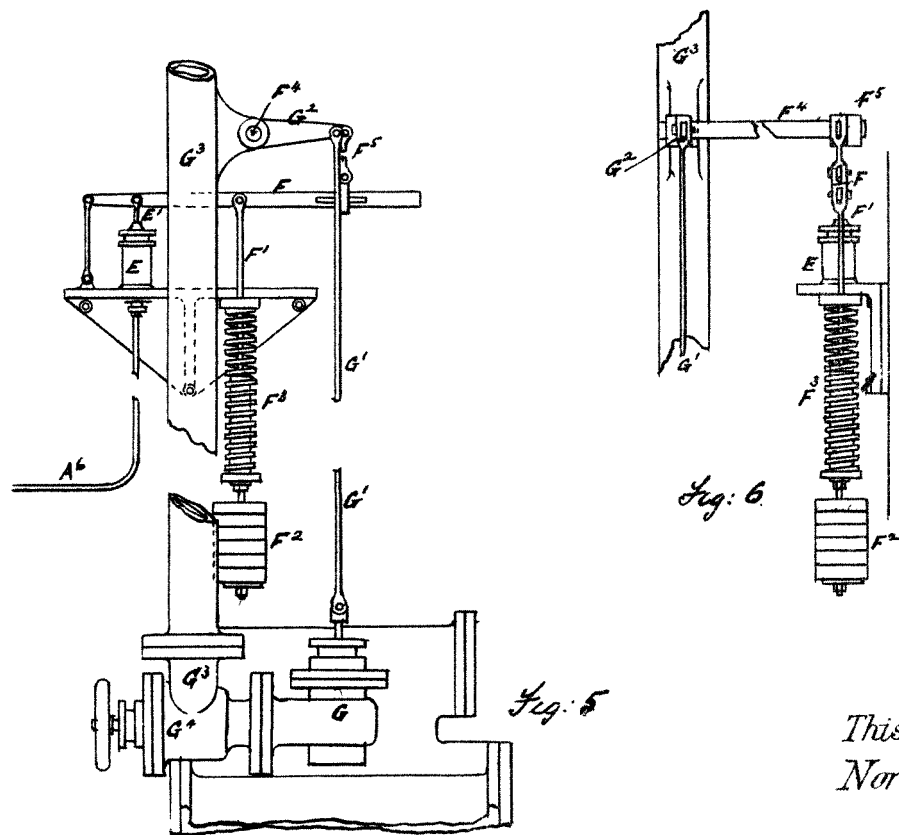


Fig. 5.

Fig. 6.

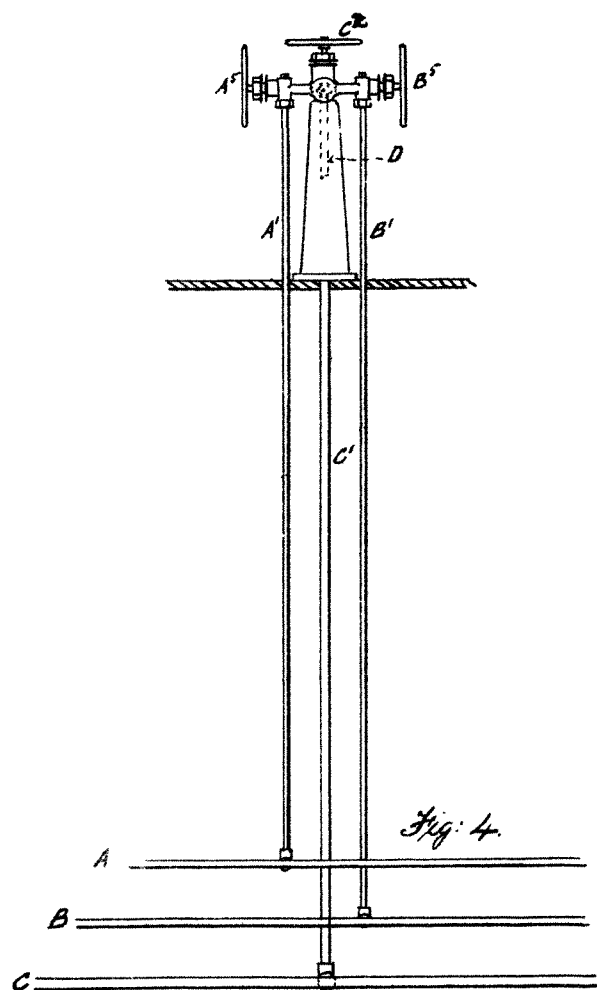


Fig. 4.

— Scale —

Figs. 1 & 2. 3 ins = 1 foot.

" 5 & 6. 1 in = "

" 3 & 4 1/2 " = "

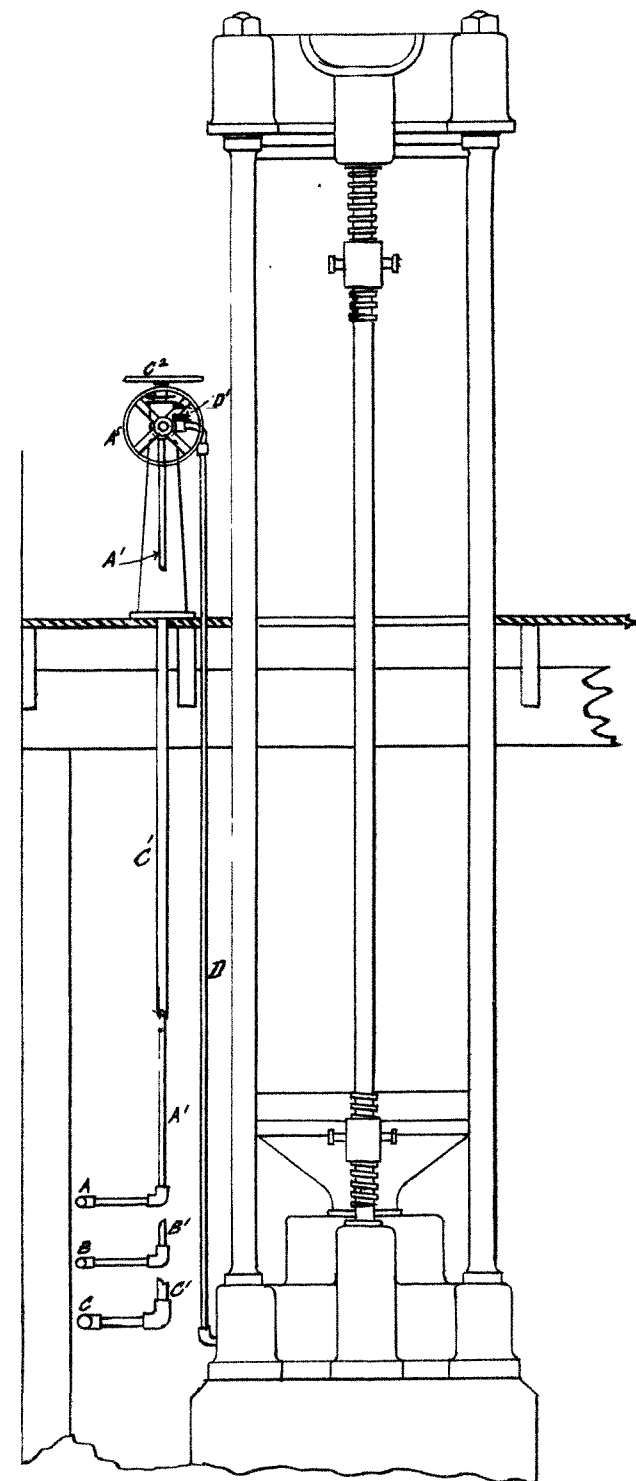


Fig. 3.

Norman Selfe's Patent.

*This is the sheet of Drawings referred to in the annexed Letters of Registration granted to Norman Selfe, this twenty first day of April, A.D., 1883.*

*Augustus Loftus.*



A.D. 1883, 21st April. No. 1227.

IMPROVEMENTS IN ELECTRIC LAMPS.

LETTERS OF REGISTRATION to Joseph Wilson Swan, for Improvements in and connected with Electric Lamps.

[Registered on the 23rd day of April, 1883, in pursuance of the Act 16 Vic. No. 24.]

BY HIS EXCELLENCY THE RIGHT HONORABLE SIR AUGUSTUS WILLIAM FREDERICK SPENCER LOFTUS (commonly called LORD AUGUSTUS LOFTUS), Knight Grand Cross of the Most Honorable Order of the Bath, a Member of Her Majesty's Most Honorable Privy Council, Governor and Commander-in-Chief of the Colony of New South Wales and its Dependencies.

TO ALL TO WHOM THESE PRESENTS SHALL COME, greeting:

WHEREAS JOSEPH WILSON SWAN, of Newcastle-on-Tyne, in the Kingdom of England, chemist, hath by his Petition humbly represented to me that he is the author or designer of a certain invention or improvement in manufactures, that is to say, of an invention entitled, "Improvements in and connected with Electric Lamps," which is more particularly described in the amended specification and the sheet of drawings which are hereunto annexed; and that he, the said Petitioner, hath deposited with the Honorable the Treasurer of the said Colony of New South Wales the sum of Twenty Pounds sterling, for defraying the expense of granting these Letters of Registration, as required by the Act of Council, sixteenth Victoria, number twenty-four; and hath humbly prayed that I would be pleased to grant Letters of Registration, whereby the exclusive enjoyment and advantage of the said invention or improvement might be secured to him for a period of fourteen years: And I, being willing to give encouragement to all inventions and improvements in the arts or manufactures which may be for the public good, and having received a report favourable to the prayer of the said Petition from competent persons appointed by me to examine and consider the matters stated therein and to report thereon for my information, am pleased, with the advice of the Executive Council, and in exercise of the power and authority given to me by the said Act of Council, to grant, and do by these Letters of Registration grant unto the said Joseph Wilson Swan, his executors, administrators, and assigns, the exclusive enjoyment and advantage of the said invention or improvement, for and during the term of fourteen years from the date hereof; to have, hold, and exercise unto the said Joseph Wilson Swan, his executors, administrators, and assigns, the exclusive enjoyment and advantage thereof, for and during and unto the full end and term of fourteen years from the date of these presents next and immediately ensuing, and fully to be complete and ended: Provided always, that if the said Joseph Wilson Swan shall not, within three days after the granting of these Letters of Registration, register the same in the proper office in the Supreme Court, at Sydney, in the said Colony of New South Wales, then these Letters of Registration, and all advantages whatsoever hereby granted, shall cease and become void.

In witness whereof, I have hereunto set my sign manual, and have caused the present Letters of Registration to be sealed with the seal of the said Colony of New South Wales, at Government House, Sydney, in New South Wales, this twenty-first day of April, in the year of our Lord one thousand eight hundred and eight-three.

[L.S.]

AUGUSTUS LOFTUS.

*Improvements in Electric Lamps.*

SPECIFICATION of JOSEPH WILSON SWAN, of Newcastle-on-Tyne, in the Kingdom of England, chemist, for "Improvements in and connected with Electric Lamps."

MY invention relates to that class of electric lamps in which light is produced by passing an electric current through a conductor of carbon, so as to render it incandescent, the said carbon conductor being enclosed in a glass chamber or bulb from which the air has been exhausted.

In carrying out my said invention, I form the carbon conductor from cotton thread (or other suitable form of cotton or other material susceptible of being converted as hereinafter described) which has been subjected to the action of sulphuric acid of such a strength as to cause a change or conversion to take place in the thread (for example) of a similar character to that which is produced by the treatment of bibulous paper with sulphuric acid, according to the well-known process of making vegetable parchment. A suitable strength of sulphuric acid for the purpose is formed by mixing together about two volumes of sulphuric acid of a specific gravity of 1.845 with about one volume of water. The cotton thread, after being immersed in this solution, and allowed to remain therein for a sufficient time to effect the required conversion, is removed from the solution and washed with water until the whole of the acid is eliminated, after which it is dried and carbonized.

The carbonization may be effected by any of the suitable well-known means, but I prefer to employ for the purpose the means next hereinafter described.

I take cotton thread prepared or converted in the manner hereinbefore described, and place in it a covered crucible or vessel containing carbon, such, for example, as charcoal, or any other suitable powder which will prevent the oxidation of the contents, and cover or enclose the suitably-shaped cotton thread with or in such carbon or powder, and I then introduce the crucible or vessel into a kiln or oven, and subject the whole to an elevated temperature.

The converted cotton thread thus becomes carbonized, and is then ready for use in the lamp.

The description of cotton thread most suitable for treatment in the manner hereinbefore described is that known as crotchet cotton thread, but other kinds of cotton thread may be employed.

In the accompanying sheet of drawings figures 1 and 2 represent respectively vertical sections, taken at right angles to each other, of a lamp having a single carbon; and figures 3 and 4 are similar views to figures 1 and 2 of another lamp containing multiple carbons to be used simultaneously, the lamps being of otherwise similar construction.

*a* is the carbon formed of the prepared cotton thread, which is bent round and gripped at its two extremities by clips, *b*, of platinum, or of an alloy of platinum and iridium, or of other suitable metal, to which the upper ends of the metal conductors *c* are attached; the carbons thus arranged, together with a convenient length of the metal conductors *c*, are surrounded by a glass bulb or receptacle, *d*, and the lower ends of the said metal conductors which pass through the bottom of the glass receptacle *d* may be sealed into the same; but when metal conductors of large sectional area are employed I prefer to secure their lower ends to platinum caps, *e*, which are attached to the bottom of the glass receptacle *d* by fusing the glass round the said caps, the metal conductors either passing through the caps or terminating in them, as desired. When such platinum caps are employed it is not absolutely necessary that the conducting wires should be formed of platinum, as wires of copper, iron, silver, or other suitable metals may be employed. The conducting wires *c* are each surrounded with a glass tube, *e*<sup>2</sup> (the bore of which is a little larger than the wire), for the purpose of steadying and imparting rigidity to the metal conductor.

The carbons are thickened at their ends with any suitable material, which is united to the cotton thread by immersion in sulphuric acid in the manner hereinbefore described, the increased thickness at the terminations facilitating the attachment of the carbons to their holding clips, and preventing them from becoming heated in use. This increased thickness of the terminations of the carbons may be obtained in the following manner:—

I wrap the ends of the converted cotton thread *a* (figure 5, and enlarged view figure 5<sup>a</sup>) with strips of bibulous paper, muslin, or other suitable form of cotton or other material susceptible of being converted as before mentioned; the cotton thread thus thickened, as shown at *a*<sup>1</sup>, is then subjected to the action of sulphuric acid in the manner before referred to, and (having been washed and dried) may be compressed and shaped into arches or spirals (an example of which is shown at *a*<sup>2</sup>, in figure 5), or into other forms adapted to the lamp required, after which it is subjected to the carbonizing process hereinbefore described.

In lieu of simply covering or wrapping the converted cotton thread at the ends with bibulous paper, or other suitable material, as hereinbefore described, and in order to effect an intimate union of the ends of the carbons with the metallic conductors, I sometimes proceed in the following manner, videlicet: I cause the ends of the thread *a* (figure 6) and the conducting wires *c* to overlap, and I bind together such overlapping parts with fine wire, as shown at *c*<sup>1</sup>, and thread or other material, as hereinbefore described, or with thread, muslin, bibulous paper, or other similar material without the wire; the thread so treated is then subjected to the action of sulphuric acid, as before described, and (after washing and drying) is shaped to the required form, and submitted to the carbonizing process hereinbefore described.

Instead of proceeding in the manner last described, in order to effect the same object, videlicet, that of securing an efficient contact between the ends of the carbons and the metallic conductor which support them, I sometimes form the ends of the said metallic conductors into either flat clips *f*, as shown in end and side elevation and plan in figures 7, 7<sup>a</sup>, and 7<sup>b</sup> respectively, or tubular clips *f*, as indicated in elevation and plan in figures 8 and 8<sup>a</sup>, the flat or tubular clip being used according as the end of the carbon is of a flat or round section. These clips are compressed upon the ends of the carbon *a* by means of a ring or band, *g*, fitting on the outside so as to insure close contact between the carbon and the conductor; this contact may also be improved by the interposition of a cushion of metallic leaf.

Figures 9 and 10 represent vertical sections, taken at right angles to each other, of a lamp having applied to it the carbon, illustrated in figure 5, the ends of which are secured in the clip, illustrated in figures 7, 7<sup>a</sup>, and 7<sup>b</sup>.

The conducting wires *c* are represented as coated with glass or enamel, *c*<sup>3</sup>, this arrangement being found desirable in practice, in order to prevent ingress of air, and to guard against the evolution of gas from the wires themselves.

*Improvements in Electric Lamps.*

Figure 11 represents a vertical section of a lamp, having applied to it the carbon, illustrated in figure 6. In this example the conducting wires *c* are enclosed in a glass or enamel stem, *c*<sup>3</sup>, common to the two bifurcated at its upper extremity, as shown.

I sometimes employ in a single lamp multiple carbons of a curved form, either of the same or different lengths, and so arranged that either one or more may be rendered incandescent at the same time. An example of this arrangement is illustrated in elevation and plan in figures 12 and 13 respectively.

In this example two carbons are employed, arranged respectively at right angles to each other, and marked *a*, *a*<sup>1</sup>; one end of each of these carbons is attached to a conducting wire, *c*, common to the two, the said ends entering respectively sockets *h*, *h*<sup>1</sup>, carried by the wire *c*; the other ends of the two carbons *a*, *a*<sup>1</sup> are respectively attached to other wires, *c*<sup>1</sup>, *c*<sup>2</sup>, by entering sockets *h*<sup>2</sup>, *h*<sup>3</sup> in a similar manner. By connecting therefore either or both of the wires *c*<sup>1</sup>, *c*<sup>2</sup> with the source of electricity, either of the carbons *a*, *a*<sup>1</sup> may be used separately, or both may be used in conjunction, as desired.

Similarly, a greater number than two carbons may be applied to a single lamp, any one or more of which may be used separately, or all of which may be used in conjunction, and either of the same or of different sizes.

This arrangement admits of the degree of light being varied as required, and also of readily bringing a spare carbon or carbons into action in the event of the fracture of one or more of the carbons which are in use.

As a preliminary process in the preparation of the cotton thread *I*, by preference, compress it by passing it through a die, or through plates, or by pressing it in a mould, or by rolling it through rollers in order to render the thread perfectly uniform in texture and section throughout its length, these conditions being indispensable to the durability of the carbon.

I also sometimes increase the superficial area of the thread by flattening it, whereby a larger extent of radiating surface is obtained, and consequently a greater amount of light from a given current.

I also may construct the carbons of compound threads, formed by taking a small thread, *1*, figure 14 (converted by the action of sulphuric acid) as a core, and winding round it spirally a number of other threads, *2*, either in their natural condition or after they have been subjected to the said converting process, the compound thread thus formed being then submitted to the said converting process or not, previously to its carbonization, in the manner hereinbefore explained. Or, in lieu of the last-named combination, I may lay a number of small threads, *1*, together parallel with their axes, so as to form a bundle, as shown in figure 15, and subject this compound thread to the process of conversion as before, so as to unite them together in one homogeneous mass; or I may simply lay the threads side by side, as indicated in figure 16, and unite them together laterally by subjecting them to the converting process as before, a tape-like form of carbon being produced in the latter case, which provides a large superficial area and extent of radiating surface.

In all cases *I*, by preference, thicken the ends of the carbons in the manner hereinbefore described.

I prefer to carry on the conversion of the threads in vacuo.

In lieu of producing the carbon from cotton thread, or other suitable material, as before mentioned, I may form it of a strip of paper or cardboard, or of a strip (figure 17) of parchment paper (vegetable parchment) produced by immersing bibulous paper in sulphuric acid, and then washing with water and drying. The strip of paper or cardboard, or parchment paper thickened at its ends, is then bent into the form of an arch or hoop, as shown in figure 18, and carbonized in the manner hereinbefore described.

It is found advantageous to exhaust the air from the glass bulb or receptacle *d* whilst the carbon conductor contained within it is raised (by the passage of a current of electricity) to the same degree of incandescence as to a higher degree of incandescence than that ultimately required to be produced in using the lamp. In order to accomplish this result I connect the glass bulb or receptacle to an exhaust apparatus, such, for example, as what is known as a Sprengel air-pump, and work the air-pump until not more than the one-thousandth part of an atmosphere remains in the bulb or receptacle; I then pass a current of electricity through the carbon so as to render it incandescent, and during the incandescence of the carbon I continue the exhaustion further until the residue of air is so small as practically not to affect the durability of the carbon when kept in a state of incandescence, the glass bulb or receptacle being then sealed so as to retain the vacuum produced therein.

I claim, as my invention—

First—Subjecting the previously prepared carbon conductors in electric lamps to the carbonizing process in a receptacle containing powered carbon or its equivalent.

Second—Constructing such conductors of compound threads, as in figures 14, 15, and 16.

In witness whereof, I, the said Joseph Wilson Swan, have, to this my specification, set my hand and seal, this twenty-third day of April, one thousand eight hundred and eighty-one.

JOSEPH WILSON SWAN.

Signed, sealed, and delivered in the }  
presence of—

ROBERT SPENCER WALDON, Solicitor, Newcastle-on-Tyne.

FREDERICK WALTER DENDY, Notary Public, Newcastle-on-Tyne, England.

This is the amended specification referred to in the annexed Letters of Registration granted to Joseph Wilson Swan, this twenty-first day of April, A.D. 1883.

AUGUSTUS LOFTUS.

*Improvements in Electric Lamps.*

## REPORTS.

Sir, Sydney, 18 July, 1881.  
We do ourselves the honor to report, in reply to your blank-cover communication of the 5th instant, No. 6,385, we find on examination that the details set forth in Mr. Joseph Wilson Swan's specification, drawing, and claim "for Improvements in and connected with Electric Lamps," assimilates registrations at present granted and in force in this Colony, and that we are therefore unable to recommend that the prayer of the petitioner should be granted.

We have, &c.,  
E. C. CRACKNELL.  
GOTHER K. MANN.

The Under Secretary of Justice.

Sir, Sydney, 24 August, 1881.  
In reply to your blank-cover communication of the 29th ultimo, No. 7,558, transmitting Mr. Edward Waters' note, *re* Mr. J. W. Swan's application for Letters of Registration, we do ourselves the honor to state that we would refer Mr. Waters to Mr. Thomas Alva Edison's registrations.

We have, &c.,  
GOTHER K. MANN.  
E. C. CRACKNELL.

The Under Secretary of Justice.

Sir, Sydney, 4 October, 1881.  
In reply to your blank-cover communication of the 19th ultimo, No. 9,076, we do ourselves the honor to state that we are of opinion if Mr Swan's claims were confined to the second and third points specified in Mr. Edward Waters' note of the 14th September last, the Board would be enabled to recommend their registration.

We have, &c.,  
E. C. CRACKNELL.  
GOTHER K. MANN.

The Under Secretary of Justice.

Sir, Sydney, 1 December, 1881.  
We do ourselves the honor to state, in reply to your blank-cover communication of the 27th ultimo, transmitting Mr. E. Waters' letter of the 25th October, *re* Mr. J. W. Swan's application for Letters of Registration, that the application of sulphuric acid in the production of carbon is a well-known chemical process; we are therefore unable to recommend its specific registration.

We have, &c.,  
E. C. CRACKNELL.  
GOTHER K. MANN.

The Under Secretary of Justice.

Sir, Sydney, 5 February, 1883.  
In reference to your blank cover of the 29th ultimo, No 1,314, transmitting Mr. Waters' further communication *re* J. W. Swan's application for Letters of Registration, we do ourselves the honor to refer to our report of the 4th October, 1881, from which we see no grounds whatever to deviate.

We have, &c.,  
E. C. CRACKNELL.  
GOTHER K. MANN.

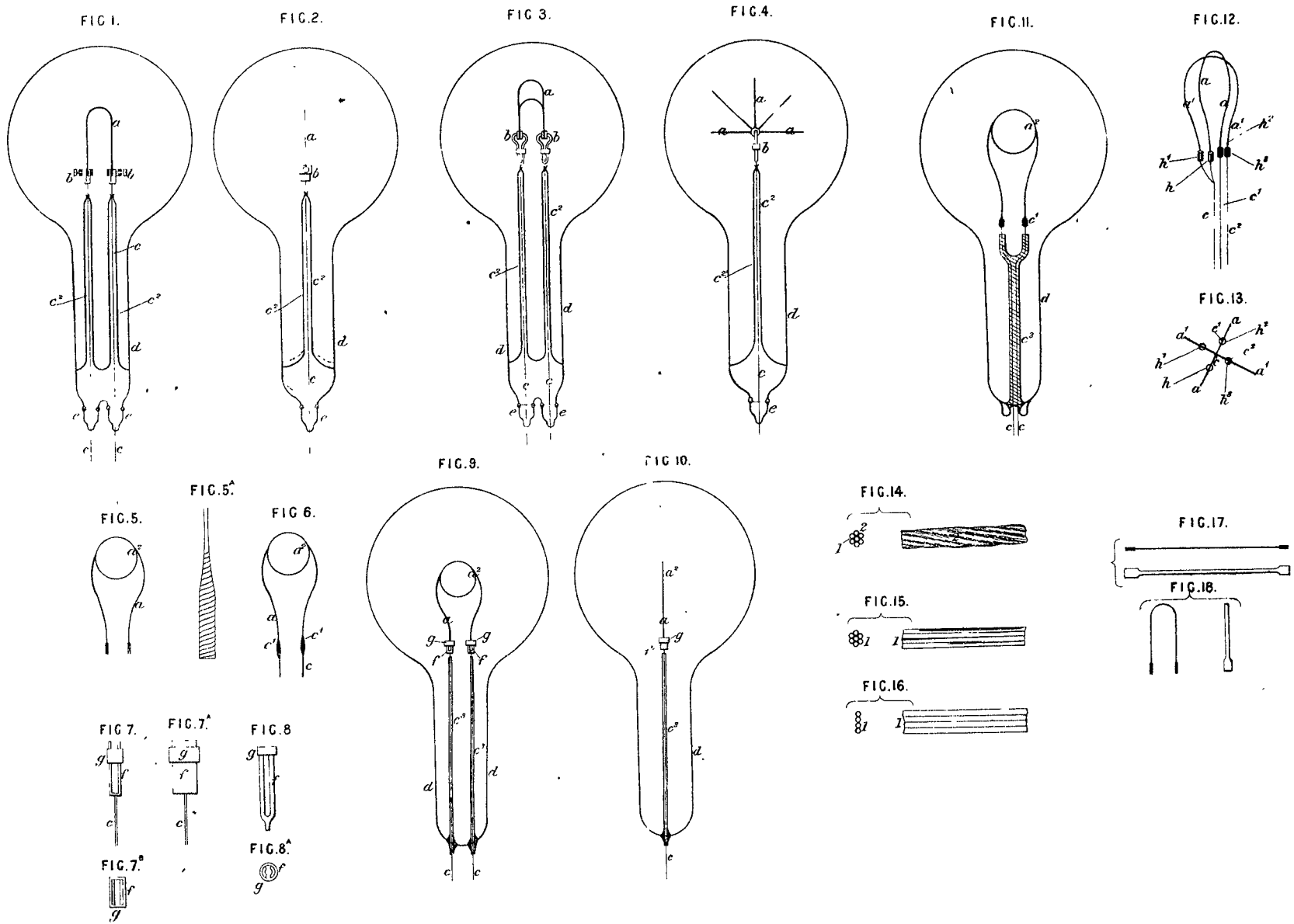
The Under Secretary of Justice.

Sir, Sydney, 5 March, 1883.  
We do ourselves the honor to report, in reply to your blank cover of the 12th ultimo, No. 2,239, transmitting Mr. J. W. Swan's revised specification and claim for registration of "Improvements in and connected with Electric Lamps," that we are of opinion the prayer of Mr. Swan's petition may now be granted in accordance therewith.

We have, &c.,  
E. C. CRACKNELL.  
GOTHER K. MANN.

The Under Secretary of Justice.





*This is the Sheet of Drawings referred to in the annexed  
 Letters or Registration granted to Joseph William Swan,  
 this twenty first day of April, A. D. 1883.*

*(Sig. 35-)*

*Augustus Loftus.*



A.D. 1883, 21st April. No. 1228.

**IMPROVEMENTS IN CONGLOMERATING PARTICLES FOR ROASTING AND SMELTING.**

**LETTERS OF REGISTRATION** to Eli Fraizer Russell, for Improvements in the art or process of conglomerating particles for Roasting and Smelting, &c.

[Registered on the 23rd day of April, 1883, in pursuance of the Act 16 Vic. No. 24.]

BY HIS EXCELLENCY THE RIGHT HONORABLE SIR AUGUSTUS WILLIAM FREDERICK SPENCER LOFTUS (commonly called LORD AUGUSTUS LOFTUS), Knight Grand Cross of the Most Honorable Order of the Bath, a Member of Her Majesty's Most Honorable Privy Council, Governor and Commander-in-Chief of the Colony of New South Wales and its Dependencies.

TO ALL TO WHOM THESE PRESENTS SHALL COME, greeting :

WHEREAS ELI FRAIZER RUSSELL, of the City and County of San Francisco, State of California, in the United States of America, hath by his Petition humbly represented to me that he is the author or designer of a certain invention or improvement in manufactures, that is to say, of an invention entitled "Improvements in the art or process of conglomerating particles for Roasting and Smelting, which is applicable particularly for forming black sand into bricks in the manufacture of iron and steel from black sand," which is more particularly described in the specification which is hereunto annexed; and that he, the said Petitioner, hath deposited with the Honorable the Treasurer of the said Colony of New South Wales the sum of Twenty Pounds sterling for defraying the expense of granting these Letters of Registration, as required by the Act of Council, sixteenth Victoria, number twenty-four, and hath humbly prayed that I would be pleased to grant Letters of Registration whereby the exclusive enjoyment and advantage of the said invention or improvement might be secured to him for a period of fourteen years: And I, being willing to give encouragement to all inventions and improvements in the arts or manufactures which may be for the public good, and having received a report favourable to the prayer of the said Petition from competent persons appointed by me to examine and consider the matters stated therein and to report thereon for my information, am pleased, with the advice of the Executive Council, and in exercise of the power and authority given to me by the said Act of Council, to grant, and do by these Letters of Registration grant unto the said Eli Fraizer Russell, his executors, administrators, and assigns, the exclusive enjoyment and advantage of the said invention or improvement, for and during the term of fourteen years from the date hereof; to have, hold, and exercise unto the said Eli Fraizer Russell, his executors, administrators, and assigns, the exclusive enjoyment and advantage thereof for and during and unto the full end and term of fourteen years from the date of these presents next and immediately ensuing, and fully to be complete and ended: Provided always, that if the said Eli Fraizer Russell shall not, within three days after the granting of these Letters of Registration, register the same in the proper office in the Supreme Court, at Sydney, in the said Colony of New South Wales, then these Letters of Registration and all advantages whatsoever hereby granted, shall cease and become void.

In witness whereof, I have hereunto set my sign manual, and have caused the present Letters of Registration to be sealed with the seal of the said Colony of New South Wales, at Government House, Sydney, in New South Wales, this twenty-first day of April, in the year of our Lord one thousand eight hundred and eighty-three.

[L.S.]

AUGUSTUS' LOFTUS.

*Improvements in conglomerating particles for Roasting and Smelting.*

SPECIFICATION of ELI FRAIZER RUSSELL, of the City and County of San Francisco, State of California, in the United States of America, for an invention entitled "Improvements in the art or process of conglomerating particles for Roasting and Smelting, which is applicable particularly for forming black sand into bricks in the manufacture of iron and steel from black sand."

This invention relates to the manufacture of iron and steel from the natural magnetic sand commonly known as black sand, which is found in large quantities on the Pacific Coast.

It has long been known that this article is capable of yielding steel of the finest quality, but it cannot be smelted in its natural state in mass as it smothers the fire. To obviate this objection the sand has heretofore been mixed with tar or asphalt, and formed into bricks, blocks, or compact lumps, but this adhesive material is soon consumed under the high temperature to which it is necessary to subject the bricks in order to smelt the sand. The particles are liberated before the smelting is completed, and the smelting process is arrested by the smothering of the fire.

I have discovered that if the sand be first saturated with a solution of animal glue, and then formed into bricks, the particles will remain cohesive under the high degree of heat necessary to smelt them.

The invention consists in that improvement in the art of manufacturing iron and steel from magnetic black sand which consists in saturating the sand with a solution of animal glue, then forming the saturated sand into blocks, and then subjecting the blocks to the smelting process.

The invention consists further in a new article of manufacture consisting of a steel-producing compressed block composed of magnetic iron, sand, and animal glue.

In carrying out my invention, I take any desired quantity of the magnetic sand and saturate the mass with a solution of animal glue, which need not be strong, but sufficiently so to cause the particles to adhere when moulded into bricks. I then mould the saturated mass into bricks, blocks, or lumps. The bricks thus formed can be placed directly into the blast furnace and subjected to the smelting temperature without losing their cohesion.

What I claim as the invention is,—

First.—The process of reducing magnetic or iron sand, consisting in first saturating the sand with a solution of animal glue, then moulding the saturated mass into bricks, and then subjecting the bricks to the smelting process at a high temperature, substantially as described.

Second.—As a new article of manufacture, of steel-producing compressed brick composed of magnetic or iron sand and animal glue, the particles of which retain their cohering properties under high smelting temperatures, substantially as described.

In witness whereof, I, the said Eli Fraizer Russell, have hereunto set my hand and seal, this nineteenth day of February, 1883.

Witness,—

W. S. BAYSTON, Law Clerk, Melbourne.

ELI FRAIZER RUSSELL.

By his attorney, EDWD. WATERS.

This is the specification referred to in the annexed Letters of Registration granted to Eli Fraizer Russell, this twenty-first day of April, A.D. 1883.

AUGUSTUS LOFTUS.

### REPORT.

Sir,

Having examined the specification accompanying the Petition, we have the honor to recommend that Letters of Registration should be issued to Mr. Eli Fraizer Russell for the invention of "Improvements in the art or process of conglomerating particles for roasting and smelting, &c.," as described in the specification attached to the Petition.

We have, &c.,

JAMES BARNET.

CHAS. WATT.

The Under Secretary of Justice.

Sydney, 1 March, 1883.




---

A.D. 1883, 21st April. No. 1229.

---

IMPROVEMENTS IN ELECTRIC LAMP APPARATUS.

LETTERS OF REGISTRATION to Charles Francis Brush, for Improvements in Electric Lamp Apparatus.

[Registered on the 23rd day of April, 1883, in pursuance of the Act 16 Vic. No. 24.]

---

BY HIS EXCELLENCY the RIGHT HONORABLE SIR AUGUSTUS WILLIAM FREDERICK SPENCER LOFTUS (commonly called LORD AUGUSTUS LOFTUS), Knight Grand Cross of the Most Honorable Order of the Bath, a Member of Her Majesty's Most Honorable Privy Council, Governor and Commander-in-Chief of the Colony of New South Wales and its Dependencies.

TO ALL TO WHOM THESE PRESENTS SHALL COME, greeting :

WHEREAS CHARLES FRANCIS BRUSH, of Cleveland, United States of America, electrical engineer, hath by his Petition humbly represented to me that he is the author or designer of a certain invention or improvement in manufactures, that is to say, of an invention entitled "Improvements in Electric Lamp Apparatus," which is more particularly described in the amended specification and the sheet of drawings which are hereunto annexed ; and that he, the said Petitioner, hath deposited with the Honorable the Treasurer of the said Colony of New South Wales the sum of Twenty Pounds sterling, for defraying the expense of granting these Letters of Registration, as required by the Act of Council, sixteenth Victoria, number twenty-four ; and hath humbly prayed that I would be pleased to grant Letters of Registration, whereby the exclusive enjoyment and advantage of the said invention or improvement might be secured to him for a period of fourteen years : And I, being willing to give encouragement to all inventions and improvements in the arts or manufactures which may be for the public good, and having received a report favourable to the prayer of the said Petition from competent persons appointed by me to examine and consider the matters stated therein and to report thereon for my information, am pleased, with the advice of the Executive Council, and in exercise of the power and authority given to me by the said Act of Council, to grant, and do by these Letters of Registration grant unto the said Charles Francis Brush, his executors, administrators, and assigns, the exclusive enjoyment and advantage of the said invention or improvement, for and during the term of fourteen years from the date hereof ; to have, hold, and exercise unto the said Charles Francis Brush, his executors, administrators, and assigns, the exclusive enjoyment and advantage thereof, for and during and unto the full end and term of fourteen years from the date of these presents next and immediately ensuing, and fully to be complete and ended : Provided always, that if the said Charles Francis Brush, shall not, within three days after the granting of these Letters of Registration, register the same in the proper office in the Supreme Court, at Sydney, in the said Colony of New South Wales, then these Letters of Registration, and all advantages whatsoever hereby granted, shall cease and become void.

In witness whereof, I have hereunto set my sign manual, and have caused the present letters of Registration to be sealed with the seal of the said Colony of New South Wales, at Government House, Sydney, in New South Wales, this twenty-first day of April, in the year of our Lord one thousand eight hundred and eighty-three.

[L.S.]

AUGUSTUS LOFTUS.

---

*Improvements in Electric Lamp Apparatus.*

SPECIFICATION of CHARLES FRANCIS BRUSH, of Cleveland, United States of America, electrical engineer, for an invention entitled "Improvements in Electric Lamp Apparatus."

THE invention relates to electric lamps, and especially to that class known as incandescent electric lamps, wherein a filament of carbon or other suitable conductor is raised to a high temperature by the passage of an electric current, and is protected from oxidation by being enclosed in a transparent receptacle, in which is maintained as perfect a vacuum as possible; and it consists in devices, hereinafter specified, whereby the liability of the incandescent filament to spontaneous rupture is largely diminished, and whereby it may safely be worked at a higher degree of incandescence than heretofore; thus securing, in the production of light, greater economy of current energy, as well as greater durability.

It is well known that in incandescent electric lamps wherein carbon filaments are used as the incandescing material the best results are attained, and the greatest durability secured, when the vacuum surrounding the filament is as perfect as it is practically possible to make it; that is, when the residual gas has a density about, or less than, one-millionth its density at atmospheric pressure. But even under these circumstances the filament is liable to break at any moment, especially if worked at a high degree of incandescence; and it is also gradually disintegrated and worn away, many of its particles being deposited on the glass envelope.

The well-known scientist, Mr. Wm. Crookes, F.R.S., has shown that gases under the low pressures I have indicated possess properties quite distinct from those displayed under ordinary circumstances, and he has given to the atoms or molecules of gases in this highly attenuated condition the name "Radiant Matter." Mr. Crookes has shown that radiant matter is thrown into violent commotion by the presence of a highly negatively electrified body, and also by a highly heated body. He has also shown that the particles of radiant matter are projected in straight lines from, and in directions normal to, the surface of the exciting body, and that the projected atoms or molecules are capable of exerting powerful mechanical action on any object interposed in their path. Mr. Crookes calls this phenomenon "Molecular Bombardment," and describes its action, under carefully regulated conditions, as capable of mechanically heating refractory solids to a white heat, and fusing or disintegrating them. Under any circumstances in which this molecular bombardment can obtain its mechanical action on solid bodies is very considerable. That this molecular bombardment obtains in the ordinary incandescent electric lamps with carbon filaments there can be no doubt; and when the horseshoe form, or coiled form, of filament is employed each limb of the filament is exposed to the destructive action of the gaseous molecules projected from the other limb. The higher the temperature of the filament the more energetic does this action become, while, at the same time, the filament, being subjected to greater internal molecular strain, is less capable of resisting external violence. The action of the flying molecules on the incandescent filament is twofold: 1st, particles of carbon are torn or ground off from the filament; the action in this case is analogous to that of the well-known "sandblast." Owing to the irregular discharging or projecting surface of each limb of the filament the bombarding action is more concentrated on some points than on others, and these points are more rapidly worn away. 2nd, the filament is thrown into irregular and violent mechanical vibration by the blows showered upon it. Finally the filament, which may at first have been practically uniform in size and strength, breaks at the point where the attack upon it is most energetic.

I avoid the above-described evils by constructing incandescent electric lamps with a suitable screen between the limbs of the bent filament thereof, whereby the "radiant matter" projected from any part of the latter is prevented from exerting its destructive action on other portions.

In the drawings, Fig. 1 shows, in vertical and horizontal cross-section, an incandescent electric lamp embodying the invention. Figs. 2 and 3 illustrate modified forms of screen.

In Fig. 1, *a b* are the usual platinum conductors passing through the glass stem *c*, and attached to the ends of and supporting the bent filament *d*, of incandescing material. *E* is a screen, preferably of glass, and in the form of a small rod or tube, attached by fusion or otherwise to the glass stem *c*, and lying in the plane of the filament loop *d d*. *H* is the glass globe enclosing the parts before described, and in which the customary high vacuum is maintained.

Now, since the "radiant matter" within the chamber *H* is projected in straight lines from all parts of the incandescent filament *d*, each limb of the latter is protected from the action of the flying molecules from the other limb by the interposition of the screen *E*.

Fig. 2 shows a flat screen, *E*, preferably of glass or mica.

Fig. 3 indicates the screen *E* arranged as a tube enclosing one limb of the incandescent filament *d*. The tube *E* (of glass or other transparent material) may be split at one side as shown, to facilitate construction. Each limb, *d*, of the filament may be provided with a tubular screen if desirable.

In carrying out this portion of the invention, I do not limit myself to any particular form of incandescent electric lamp, nor to any particular form or construction of the screen *E*, nor to any particular material of which the screen shall be made; metal or other opaque substance may be used if desired. Neither do I limit myself to any particular manner of attaching or supporting the screen *E*.

Having described the invention in its various forms, I claim:—

- 1st. An incandescent electric lamp having an incandescing filament or conductor of "horseshoe" or equivalent form, and provided with a screen between the limbs of the said filament, substantially as and for the purpose set forth.
- 2nd. In an incandescent electric lamp, the combination of an incandescing filament or conductor of "horseshoe" or equivalent form, and a screen located between the limbs of the said filament, substantially as and for the purpose described.

In witness whereof, I, the said Charles Francis Brush, have hereto set my hand and seal, this twenty-seventh day of September, one thousand eight hundred and eighty-two.

CHARLES FRANCIS BRUSH.

Witness—

LEVERETT L. LEGGETT.

This

---

*Improvements in Electric Lamp Apparatus.*

---

This is the amended specification referred to in the annexed Letters of Registration granted to Charles Francis Brush, this twenty-first day of April, A.D. 1883.

AUGUSTUS LOFTUS.

---

REPORTS.

---

Sir,

Sydney, 27 December, 1882.

We do ourselves the honor to report, in reply to your blank-cover communication of the 19th instant, No. 13,945, transmitting Mr. Charles Francis Brush's application for the registration of "Improvements in Electric Lamp Apparatus," that we are of opinion the only portion of Mr. Brush's claim that can be granted is the screen; and we recommend the prayer of the Petition to that extent only.

We have, &amp;c.,

E. C. CRACKNELL.  
GOTHER K. MANN.

The Under Secretary of Justice.

Sir,

Sydney, 17 January, 1883.

In reply to your blank cover of the 9th instant, transmitting Mr. Waters' further communication *re* Mr. C. F. Brush's claim for "Improvements in Electric Lamp Apparatus," we do ourselves the honor to state that we see no grounds for deviating from our report of the 27th December last, being clearly of opinion that the sectional form of the carbon is not a novelty for registration, and as Mr. Brush has a perfect right to use any sectional form he thinks proper, no one in particular can be granted for his exclusive use.

We have, &amp;c.,

E. C. CRACKNELL.  
GOTHER K. MANN.

The Under Secretary of Justice.

Sir,

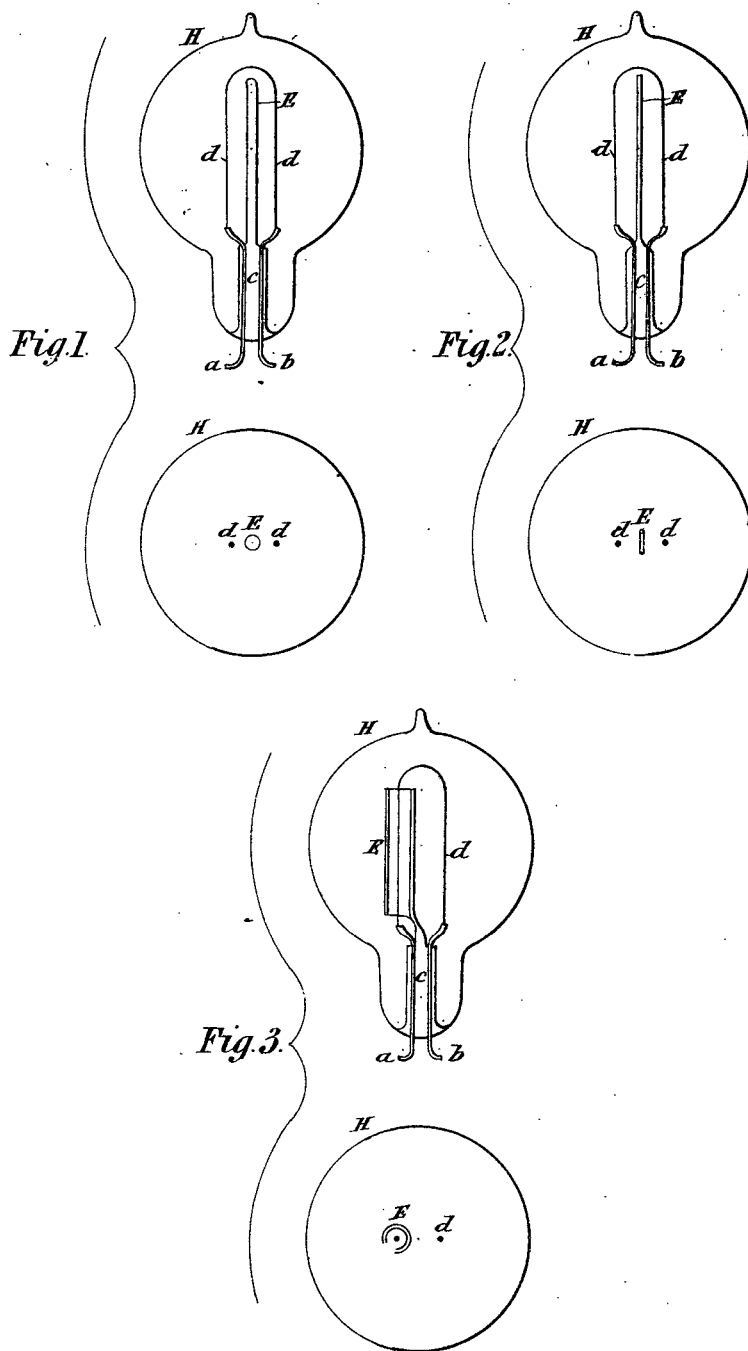
Sydney, 5 March, 1883.

We do ourselves the honor to report, in reply to your blank cover of the 12th ultimo, transmitting Mr. C. F. Brush's revised specification and claim for "Improvements in Electric Lamps," that we are of opinion the prayer of Mr. Brush's petition may now be granted in accordance therewith.

We have, &amp;c.,

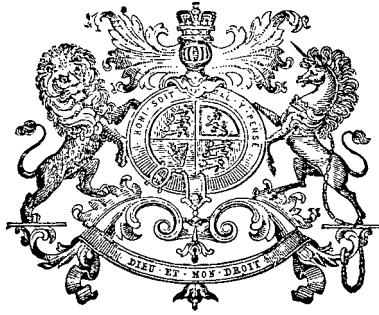
E. C. CRACKNELL.  
GOTHER K. MANN.

The Under Secretary of Justice.



*This is the Sheet of Drawings referred to in the annexed Letters of Registration granted to Charles Francis Brush, this twenty first day of April A.D. 1883.*

*Augustus Loftus.*



A.D. 1883, 21st April. No. 1230.

**PRODUCTION OF SULPHUROUS ACID GAS, TO BE EMPLOYED IN THE  
MANUFACTURE OF SUGAR.**

**LETTERS OF REGISTRATION** to Charles D'Abadie de Barrau, for the production of Sulphurous Acid Gas, to be employed in the manufacture of Sugar.

[Registered on the 23rd day of April, 1883, in pursuance of the Act 16 Vic. No. 24.]

BY HIS EXCELLENCY THE RIGHT HONORABLE SIR AUGUSTUS WILLIAM FREDERICK SPENCER LOFTUS (commonly called LORD AUGUSTUS LOFTUS), Knight Grand Cross of the Most Honorable Order of the Bath, a Member of Her Majesty's Most Honorable Privy Council, Governor and Commander-in-Chief of the Colony of New South Wales and its Dependencies.

TO ALL TO WHOM THESE PRESENTS SHALL COME, greeting :

WHEREAS CHARLES D'ABADIE DE BARRAU, of Curepipe, in the district of Wilhem Plains, in the Island of Mauritius, chemist, hath by his Petition humbly represented to me that he is the author or designer of a certain invention or improvement in manufactures, that is to say, of an invention for the "Production of Sulphurous Acid Gas, to be employed in the manufacture of Sugar," which is more particularly described in the specification and the sheet of drawings which are hereunto annexed ; and that he, the said Petitioner, hath deposited with the Honorable the Treasurer of the said Colony of New South Wales the sum of Twenty Pounds sterling, for defraying the expense of granting these Letters of Registration, as required by the Act of Council, sixteenth Victoria, number twenty-four ; and hath humbly prayed that I would be pleased to grant Letters of Registration, whereby the exclusive enjoyment and advantage of the said invention or improvement might be secured to him for a period of fourteen years : And I, being willing to give encouragement to all inventions and improvements in the arts or manufactures which may be for the public good, and having received a report favourable to the prayer of the said Petition, from competent persons appointed by me to examine and consider the matters stated therein and to report thereon for my information, am pleased, with the advice of the Executive Council, and in exercise of the power and authority given to me by the said Act of Council, to grant, and do by these Letters of Registration grant unto the said Charles D'Abadie de Barrau, his executors, administrators, and assigns, the exclusive enjoyment and advantage of the said invention or improvement, for and during the term of fourteen years from the date hereof ; to have, hold, and exercise unto the said Charles D'Abadie de Barrau, his executors, administrators, and assigns, the exclusive enjoyment and advantage thereof, for and during and unto the full end and term of fourteen years from the date of these presents next and immediately ensuing, and fully to be complete and ended : Provided always, that if the said Charles D'Abadie de Barrau shall not, within three days after the granting of these Letters of Registration, register the same in the proper office in the Supreme Court, at Sydney, in the said Colony of New South Wales, then these Letters of Registration, and all advantages whatsoever hereby granted, shall cease and become void.

In witness whereof, I have hereunto set my sign manual, and have caused the present Letters of Registration to be sealed with the seal of the said Colony of New South Wales, at Government House, Sydney, in New South Wales, this twenty-first day of April, in the year of our Lord one thousand eight hundred and eighty-three.

[L.S.]

AUGUSTUS LOFTUS.



*Production of Sulphurous Acid Gas, to be employed in the manufacture of Sugar.*

I, CHARLES D'ABADIE DE BARRAU, of Curepipe, in the district of Wilhems Plains, in the Island of Mauritius, chemist, being the author or designer of a certain invention in or improvement to the arts or manufactures, that is to say, an invention for the "Production of Sulphurous Acid Gas, to be employed in the manufacture of Sugar," the particulars whereof I hereby declare to be and specify as follows, reference being had to plan accompanying, where letters are hereafter mentioned:—

A capsule-shaped vessel of thin metal, A, mounted on three or four stout screws, at the end of the balance-beam B.

A lid or covering, G, resting on the uprights D.

Two holes or doors, C, through which the sulphur to be burnt is charged.

A tube or cylinder, D<sup>1</sup>, which intercepts the sulphurous vapours at the centre of the vessel.

The upper section of the apparatus at E being surrounded by a supply of water the vapours are driven into the canal F, where they are met by a supply of cold water, turned on from the outside by a cock or tap, K.

This water is partly held in a state of suspension here by the two ledges or barriers marked *ff*; one of these ledgers is somewhat higher than the other, which prevents the water from finding its way into the vessel A, and the overflow falls into compartment H.

The pipe II, which receives a jet of steam from a boiler mixed with inhaled gas, is completely emerged by the small stream of water running from point F. A door, Q, kept in place by a strap, allows of the inspection of the apparatus whilst at work, and facilitates the replacing of the pipe H, which is movable, and could be made use of if the machine was short of water.

The pipe T, through which the steam reaches the apparatus, is made of strong metal, and in fixing or riveting it a sufficient length is allowed to bring it within about a distance of a centimetre from the tube H. The space between these two pipes can also be regulated by raising the latter.

The reservoir S tends to keep the apparatus cool, and it might be constructed in the form of a funnel or casting enveloping the whole of the canal F, through which an incessant stream of cold water could be made to circulate, at the same time profiting by another current of water which formerly ran through canal F.

The method of working the apparatus is as follows:—

The sulphur is put in through the holes marked C, and is lit by means of a red-hot iron bar after a draught or current of air has been established by opening the steam-cock at V.

Care must be taken to keep a very small space between the capsule or vessel A and its coverlid G; this is done by the aid of the screw bolt L<sup>1</sup>. The air which penetrates through the opening ought to suffice for the purposes of promoting combustion, but an excess must be guarded against as much as possible.

The apparatus is shown on a scale of about one-fourth its proper size, and the consumption of sulphur would amount to about twenty kilogrammes (44 lb) per day of twelve hours.

This quantity could be considerably increased, however, by augmenting the jet of vapour, but in that case it would be necessary to have more water circulating both inside and out, in order to prevent the overheating of the apparatus, which could of course be constructed on a much larger scale if the business required it.

The peculiarities of the above invention are,—

First—The production of sulphurous acid gas, employed in the manufacture of sugar, by the apparatus as herein described.

Second—The use and application of such sulphurous acid, in the form of gas, in the manufacture of sugar.

Third—The general arrangement and combination of the machinery herein described, employed for the purposes as stated.

What I claim as new and to be protected by registration is,—

First—The production of sulphurous acid gas, employed in the manufacture of sugar, by the apparatus as herein described.

Second—The use and application of such sulphurous acid, in the form of gas, in the manufacture of sugar.

Third—The general arrangement and combination of the machinery herein described, employed for the purposes as stated.

As witness my hand and seal, this eleventh day of December, in the year of our Lord one thousand eight hundred and eighty.

CHARLES D'ABADIE DE BARRAU,  
By his Attorney and Agent,  
EDWARD FANNING.

Signed, sealed, and delivered by the said  
Charles D'Abadie de Barrau, by his  
attorney, Edward Fanning, in the  
presence of,—

E. KLINGENDER, Notary Public, Melbourne.

This is the specification referred to in the annexed Letters of Registration granted to Charles D'Abadie de Barrau, this twenty-first day of April, A.D. 1883.

AUGUSTUS LOFTUS.

---

*Production of Sulphurous Acid Gas, to be employed in the manufacture of Sugar.*

---

REPORTS.  

---

. Sir,

Sydney, 18 January, 1883.

The application of Mr. Charles D'Abadie de Barrau for Letters of Registration for an invention for the "Production of Sulphurous Acid Gas, to be employed in the manufacture of Sugar," having been referred to us, we have examined the specification and drawing accompanying the same, and have now the honor to report that we see no objection to the issue of Letters of Registration for the manufacture of Sulphurous Acid Gas in accordance with the accompanying drawing; but it should be distinctly understood that this should not confer the exclusive right to the employment of Sulphurous Acid Gas, that substance being already in common use.

We have, &amp;c.,

CHAS. WATT.  
A. LEIBIUS.The Under Secretary of Justice.  

---

Sir,

Sydney, 1 March, 1883.

We have the honor to acknowledge receipt of your letter of 17th February, 1883, 1,912, informing us that Mr. Charles D. de Barrau will be satisfied with the grant of Letters of Registration in accordance with our recommendation conveyed in our report of the 18th January last, and we have noted the same.

We have, &amp;c.,

CHAS. WATT.  
A. LEIBIUS.

The Under Secretary of Justice.

---

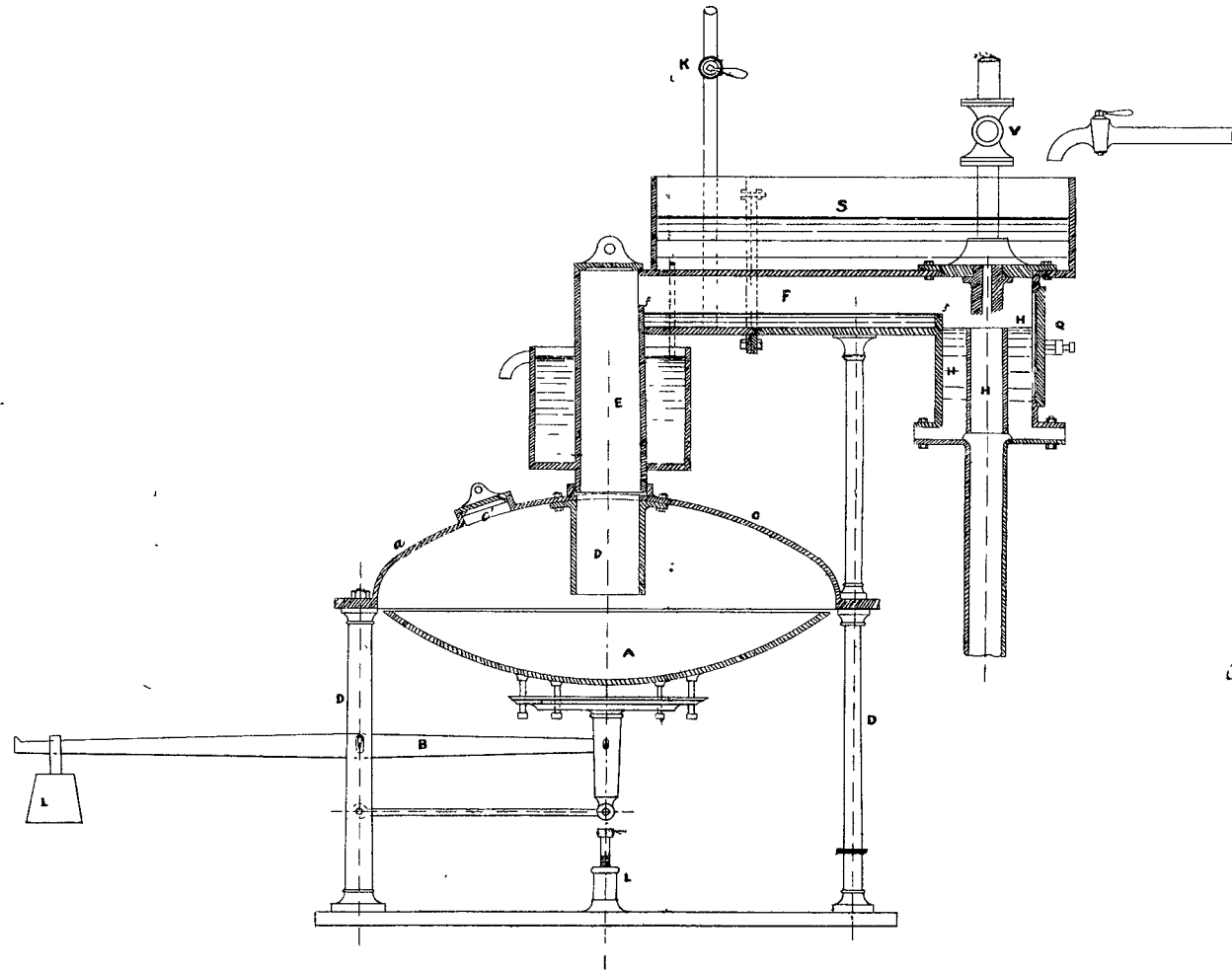
[Drawings—one sheet.]

---

## No. 1231.

[Assignment of No. 1123. See Letters of Registration for 1882, page 337.]

# BARRAU'S SULPHUROUS ACID MACHINE



*Charles Barrau de Barrau  
by his Attorney & Agent  
Edward Jennings*

*This is the Sheet of Drawings referred to in the annexed  
Letters of Registration granted to Charles Barrau de Barrau  
de Barrau, this twenty first day of April, A. D. 1883.*

PHOTO-LITHOGRAPHED AT THE GOVT. PRINTING OFFICE  
SYDNEY, NEW SOUTH WALES

*Augustus Loftus.*



A.D. 1883, 25th April. No. 1232.

IMPROVEMENTS IN THE CONSTRUCTION OF GLAZED ROOFS, &c.

LETTERS OF REGISTRATION to John Edgcumbe Rendle, for Improvements in the construction of Glazed Roofs and other glazed structures.

[Registered on the 26th day of April, 1883, in pursuance of the Act 16 Vic. No. 24.]

BY HIS EXCELLENCY THE RIGHT HONORABLE SIR AUGUSTUS WILLIAM FREDERICK SPENCER LOFTUS (commonly called LORD AUGUSTUS LOFTUS), Knight Grand Cross of the Most Honorable Order of the Bath, a Member of Her Majesty's Most Honorable Privy Council, Governor and Commander-in-Chief of the Colony of New South Wales and its Dependencies.

TO ALL TO WHOM THESE PRESENTS SHALL COME, greeting :

WHEREAS JOHN EDGCUMBE RENDLE, of 3, Westminster Chambers, Victoria-street, in the City of Westminster, England, hath by his Petition humbly represented to me that he is one of the Executors of William Edgcumbe Rendle, late of the City of Westminster aforesaid, deceased, the author or designer of a certain invention or improvement in manufactures, that is to say, of an invention entitled "Improvements in the construction of Glazed Roofs and other glazed structures," which is more particularly described in the specification and the sheet of drawings which are hereunto annexed ; and that he, the said Petitioner, hath deposited with the Honorable the Treasurer of the said Colony of New South Wales the sum of Twenty Pounds sterling, for defraying the expense of granting these Letters of Registration, as required by the Act of Council, sixteenth Victoria, number twenty-four ; and hath humbly prayed that I would be pleased to grant Letters of Registration, whereby the exclusive enjoyment and advantage of the said invention or improvement might be secured to him for a period of fourteen years : And I, being willing to give encouragement to all inventions and improvements in the arts or manufactures which may be for the public good, and having received a report favourable to the prayer of the said Petition, from competent persons appointed by me to examine and consider the matters stated therein and to report thereon for my information, am pleased, with the advice of the Executive Council, and in exercise of the power and authority given to me by the said Act of Council, to grant, and do by these Letters of Registration grant unto the said John Edgcumbe Rendle, as such executor as aforesaid, and his executors, administrators, and assigns, the exclusive enjoyment and advantage of the said invention or improvement, for and during the term of fourteen years from the date hereof ; to have, hold, and exercise unto the said John Edgcumbe Rendle, as such executor as aforesaid, and his executors, administrators, and assigns, the exclusive enjoyment and advantage thereof, for and during and unto the full end and term of fourteen years from the date of these presents next and immediately ensuing, and fully to be complete and ended : Provided always, that if the said John Edgcumbe Rendle shall not, within three days after the granting of these Letters of Registration, register the same in the proper office in the Supreme Court, at Sydney, in the said Colony of New South Wales, then these Letters of Registration, and all advantages whatsoever hereby granted, shall cease and become void.

In witness whereof, I have hereunto set my sign manual, and have caused the present Letters of Registration to be sealed with the seal of the said Colony of New South Wales, at Government House, Sydney, in New South Wales, this twenty-fifth day of April, in the year of our Lord one thousand eight hundred and eighty-three.

[L.S.]

AUGUSTUS LOFTUS.

*Improvements in the construction of Glazed Roofs, &c.*

SPECIFICATION of JOHN EDGCUMBE RENDLE, of 3, Westminster Chambers, Victoria-street, in the City of Westminster, England, for an invention entitled "Improvements in the construction of glazed roofs and other glazed structures."

THIS invention relates to the means of carrying sheets of glass in glazed structures by horizontal purlins.

According to this invention, I carry sheets of glass by horizontal purlins in the following manner:— I allow the upper ends of the sheets of glass to rest upon the face of one horizontal purlin, whilst the lower ends of the sheets of glass are received in a trough formed in bent sheet-metal bars secured to another horizontal purlin. These bent sheet-metal bars at their upper edge are formed so that they may be attached to the back or upper side of the purlins; they are also formed with a flat face, against which the back of the lower ends of the sheets of glass may rest; they are then bent back at right angles, and afterwards again have three more right-angled bends formed in them, so as to form, as it were, a rectangular tube or partially closed-over trough along the bottom of each bar. The bottom of this tube or trough rests upon the surface of the top end of the sheets of glass, and holds them down.

The sheets of glass at their bottom ends are overlapped by the last bend of the sheet metal, of which the horizontal sheet-metal bar is formed, and which covers or partially covers the trough which is along the bottom of that bar, as above mentioned. The sheets of glass are thus prevented from slipping down.

Between the abutting side edges of the sheets of glass I interpose a bar of a section similar to that shown at E, fig. 1, in the drawing annexed. These bars are made with a flat strip to lie above the glass, and cover the space or opening between them, and with a central stem to descend between the sheets of glass, and with two troughs, one on either side of the stem below the glass.

The horizontal sheet-metal bars which are attached to the purlins are cut into lengths somewhat shorter than the width of the sheets of glass, so that at their ends they may abut against the sides of the bars, which, as just stated, are placed between the side edges of the sheets of glass, and so make a close joint. The troughs at the bottom edge of the horizontal bars, which are secured to the purlins, have holes formed in them to allow any water which may flow down into them, either from the inner or outer face of the glass, to run off on to the top of the pane of glass below them.

The new horizontal metal bar is adapted for any kind of purlin, either of wood or iron, and is secured by means of screws, fastened at the back or upper portions of the purlin. When the glazing bar is fixed to iron a piece of india-rubber or felt is interposed between the same to prevent contact of the two metals, and can also be placed on the flat surface of the iron to act as a cushion for the upper edges of the glass.

Having thus described the nature of my invention, I will proceed to describe more fully the manner of performing the same.

## DESCRIPTION OF THE DRAWINGS.

Figure 1 is a plan view in perspective of a portion of a roof glazed in the above manner, and in which wooden purlins are used. Figure 2 is a vertical section of the same. Figures 3 and 4 show cross-sections of similar roofs, in which the purlins are of iron of different sections. These are only shown as examples of the forms of purlin that may be used, but it is evident that the purlins might be of other sections or forms.

The roof or other structure is formed with the requisite number of horizontal purlins or supports at a distance from one another somewhat less than the length of the sheets of glass which are to be used; one only of these supports is shown at A.

B are the sheets of glass. The upper ends of the sheets of glass lie upon the top of the purlins A, and are held down on to them by the bars C, formed of bent sheet metal. These bars are secured by screws or other fastenings to the back or upper side of the purlins, as shown. When the purlin is of iron, and the bar C of other metal, a piece of india-rubber or felt D may be interposed between them, and prevent contact of the two metals. A similar strip of soft material might also be placed between the flat surface of the purlin and the glass resting upon it, so as to form a cushion for the glass to lie upon. The bars C, in addition to holding down the upper end of one sheet of glass on to the purlin, are also, as above stated, formed to support and hold the lower ends of the sheet of glass next above it; the way in which the sheet metal of which the bar is formed has right-angled bends made in it to effect this object is clearly shown by the drawings.

The partially closed-over trough formed, as shown, along the bottom of the bar has holes, C', formed at intervals through it, so that any water which may run down into the trough, either from the inner or outer face of the glass, may run off on to the top of the sheet of glass below it. E are the bars of bent sheet metal, interposed between the abutting side edges of the sheets of glass. An end view of one of these bars is shown at figure 5. Each bar, E, is, as above stated, formed with a flat surface to cover over the space between the side edges of two adjoining sheets of glass, and also to lap over these sheets of glass to any extent required; it is also formed with a stem to descend between the sheets of glass; and also with two troughs, one on either side of the stem, and these troughs are made with flat sides and rectangular, so that the ends of the bars C may abut and fit in against them. The bars E, at their upper ends, may have the troughs cut away, so that the bars may be of the same length as the sheets of glass, and yet not render it necessary that the purlins should be cut away or recessed for the troughs of these bars to lie in. The bars C are in lengths somewhat shorter than the width of the sheets of glass used, just sufficient to allow of their ends abutting against the bars E, as shown at figure 1.

A pin, H, may be passed through the stem of the bar E near its lower end, and the ends of the pin be made to extend into the troughs of the bars C, to prevent the bars E from slipping downwards.

Figures 6 and 7 show how the top and bottom of a ridge roof glazed in the manner above described is to be formed.

Figures 8 and 9 show the way in which the vertical bars E may be formed for finishing to hips and ends of a roof.

Figure 10 shows a cross-section of a small skylight glazed as above described.

Having

---

*Improvements in the construction of Glazed Roofs, &c.*

---

Having thus described the nature of my invention, and the manner of performing the same, I would have it understood that I claim,—

First—The construction of glazed roofs and other glazed structures, substantially in the manner hereinbefore described.

Second—The construction of the horizontal bar C, substantially as described.

Third—The construction of the vertical bars E, of the improved form, substantially as described.

In witness whereof, I, the said John Edgcumbe Rendle, have hereunto set my hand and seal, this twenty-fourth day of August, 1882.

JOHN EDGCUMBE RENDLE.

This is the specification referred to in the annexed Letters of Registration granted to John Edgcumbe Rendle, this 25th day of April, A.D. 1883.

AUGUSTUS LOFTUS.

---

**REPORT.**

---

Sir,

The application of Mr. John E. Rendle, for Letters of Registration for "Improvements in the construction of Glazed Roofs and other glazed structures," having been referred to us, we have examined the plans and specification accompanying the same, and have now the honor to report that we see no objection to the issue of Letters of Registration as prayed for.

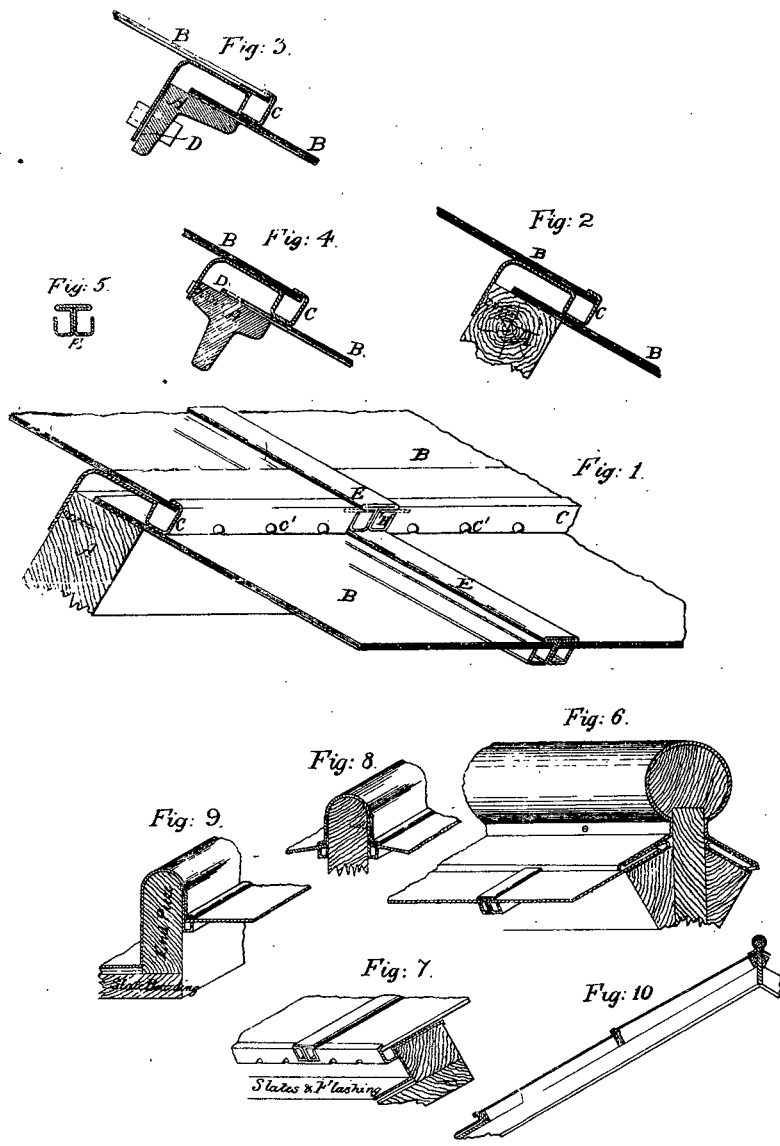
Sydney, 20 October, 1882.

We have, &c.,  
JAMES BARNET.  
EDMUND FOSBERY.

To the Under Secretary of Justice.

---

[Drawings—one sheet.]



*This is the Sheet of Drawings referred to in the annexed  
 Letters of Registration granted to John Edgcumbe  
 Rendle, this twenty fifth day of April A. D. 1883.  
 Augustus Loftus.*



A.D. 1883, 12th May. No. 1233.

IMPROVEMENTS IN FEED-WATER FILTERS, &c.

LETTERS OF REGISTRATION to the Assignees of Reese Llewellyn, for Improvements in Feed-water Filters, Heaters, Purifiers, and Condensers for Steam-boilers.

[Registered on the 12th day of May, 1883, in pursuance of the Act 16 Vic. No. 24.]

BY HIS EXCELLENCY THE RIGHT HONORABLE SIR AUGUSTUS WILLIAM FREDERICK SPENCER LOFTUS (commonly called LORD AUGUSTUS LOFTUS), Knight Grand Cross of the Most Honorable Order of the Bath, a Member of Her Majesty's Most Honorable Privy Council, Governor and Commander-in-Chief of the Colony of New South Wales and its Dependencies.

TO ALL TO WHOM THESE PRESENTS SHALL COME, greeting:

WHEREAS THE LLEWELLYN STEAM-CONDENSER MANUFACTURING COMPANY, of California, in the United States of America, have by their Petition humbly represented to me that they are the Assignees of Reese Llewellyn, of the City and County of San Francisco, California aforesaid, who is the author or designer of a certain invention or improvement in manufactures, that is to say, of an invention entitled "Improvements in Feed-water Filters, Heaters, Purifiers, and Condensers for Steam-boilers," which is more particularly described in the specification and the sheet of drawings which are hereunto annexed; and that they, the said Petitioners, have deposited with the Honorable the Treasurer of the said Colony of New South Wales the sum of Twenty Pounds sterling for defraying the expense of granting these Letters of Registration, as required by the Act of Council, sixteenth Victoria, number twenty-four; and have humbly prayed that I would be pleased to grant Letters of Registration, whereby the exclusive enjoyment and advantage of the said invention or improvement might be secured to them for a period of fourteen years: And I, being willing to give encouragement to all inventions and improvements in the arts or manufactures which may be for the public good, and having received a report favourable to the prayer of the said Petition, from competent persons appointed by me to examine and consider the matters stated therein, and to report thereon for my information, am pleased, with the advice of the Executive Council, and in exercise of the power and authority given to me by the said Act of Council, to grant, and do by these Letters of Registration grant unto the said Llewellyn Steam-condenser Manufacturing Company, their executors, administrators, and assigns, the exclusive enjoyment and advantage of the said invention or improvement, for and during the term of fourteen years from the date hereof; to have, hold, and exercise unto the said Llewellyn Steam-condenser Manufacturing Company, their executors, administrators, and assigns, the exclusive enjoyment and advantage thereof, for and during and unto the full end and term of fourteen years from the date of these presents next and immediately ensuing, and fully to be complete and ended: Provided always, that if the said Llewellyn Steam-condenser Manufacturing Company shall not, within three days after the granting of these Letters of Registration, register the same in the proper office in the Supreme Court at Sydney, in the said Colony of New South Wales, then these Letters of Registration, and all advantages whatsoever hereby granted, shall cease and become void.

In witness whereof, I have hereunto set my sign manual, and have caused the present Letters of Registration to be sealed with the seal of the said Colony of New South Wales, at Government House, Sydney, in New South Wales, this twelfth day of May, in the year of our Lord one thousand eight hundred and eighty-three.

[L.S.]

AUGUSTUS LOFTUS.



*Improvements in Feed-water Filters, &c.*

SPECIFICATION of the LLEWELLYN STEAM-CONDENSER MANUFACTURING COMPANY, of California, in the United States of America, the assignees of Ressee Llewellyn, of the City and County of San Francisco, California aforesaid, for an invention entitled "Improvements in Feed-water Filters, Heaters, Purifiers, and Condensers for Steam-boilers."

My invention relates to an apparatus for freeing water fed to steam-boilers from earthy matters held in solution therein, such as carbonate and sulphate of lime, magnesia, and the like, and for utilizing, at the same time, the otherwise waste heat of the exhaust steam.

It consists, first and essentially, of a chamber provided with a mass of loose stones, preferably cobble stones, supported in said chamber in such a manner as to permit the free passage of water and steam through and among all the stones, with a pipe in the upper part of said chamber adapted to supply the water in a uniformly diffused state over the entire mass of stones, and with a steam-supply in the chamber below the mass of stones adapted to diffuse in like manner the steam upon the lower surface and cause it to pass up through the mass, whereby the salts and other matters, such as carbonate and sulphate of lime and magnesia and silica, held in solution and producing scale in the boiler, are precipitated upon the stones and the heat of the steam utilized.

It consists, in the second place, in injecting the steam horizontally into the lower part of the chamber underneath the stones, whereby it is more uniformly diffused, brought into immediate contact with and caused to penetrate every part of the mass of stones, and approximately to heat all parts alike.

It consists, thirdly, in placing among the stones a layer of filtering material, thereby combining a precipitating and filtering apparatus in one chamber.

It is well known that the water used in many localities for the boilers of steam-engines contains, in solution, substances such as carbonate and sulphate of lime, magnesia, silica, and the like, which, when subjected to heat in the boiler, are rendered insoluble, and are deposited upon the inner surface of the boilers and tubes, forming incrustations or "scales." It is also well known that these substances are held in solution only at ordinary temperatures, to become insoluble when the water containing them is raised to a high temperature. It is for this reason that they become deposited as incrustations within the boiler. Attempts have been heretofore made to free the water before it is fed to the boilers of steam-engines from these substances, such attempts having been partially successful. Partial remedy, like that attained prior to my invention, is of little or no avail, for the reason that the incrustation, under such circumstances, still goes on, requiring that the boiler should be watched and cleansed; and it is only by perfect purification of the water in respect to these substances that the need for watchfulness in this respect can be avoided, and perfect immunity from incrustation and relief from the danger and expense incident to the formation of scale attained.

Among the devices heretofore provided for this purpose is an apparatus in which is a chamber filled with fragments of iron resting upon a partially perforated diaphragm, having a steam-pipe discharging vertically into the chamber below said diaphragm, and with a feed-water pipe adapted to supply water to said chamber above the iron fragments. I have aimed to avoid two defects incident to this apparatus—one consisting in the material used in connection with the steam and water supply; and the other relating to the manner of supplying the steam to the fragments of iron by direct discharge against an unperforated part of the diaphragm.

In another device stones are used with devices for discharging the feed-water mixed with steam over the stones for the purpose of pumping it. In this case the high degree of heat necessary to the perfect condensation of the mass held in solution cannot be attained, because the steam is not brought into direct contact with the stones; and in the former case referred to this perfect action is prevented, partly by the oxidizable nature of the material, which is acted upon by the water and prevents perfect incrustation, and partly by the solid portions of the diaphragm, which protect part of the mass from heat.

I have endeavoured to avoid all these difficulties, and have succeeded in producing an apparatus which perfectly frees the water from incrusting material and fulfills all the conditions required. This is shown in the accompanying drawings, in which—

Figure 1 represents a side elevation; figure 2, a front view of the apparatus with a portion of the shell of the chamber broken away; and figure 3, a plan view of the purifying, heating, and condensing chamber.

In these drawings, A A<sup>1</sup> represent the heating, purifying, and condensing chamber; B, the perforated diaphragm; C, the steam-chamber of the boiler; and D, the boiler.

The chamber A A<sup>1</sup> is fitted with a tight cover, and has in the top a pipe, E, for admitting the feed-water, and an outlet steam-pipe, F, for the escape of uncondensed steam. The lower portion, A, of the chamber, which receives the hot water, has a steam inlet pipe, G, and a hot-water outlet pipe, H, with a discharging pipe, I, at the bottom for removing any sediment. This apparatus is placed in any convenient position in relation to the boiler, and the steam from the engine cylinders is let into the chamber through the horizontal pipe G, just beneath the perforated diaphragm, while the hot water is drawn off through the pipe H and let into the boiler. Within the chamber A A<sup>1</sup> is placed a quantity of cobble stones or other bodies of like nature, of irregular shape, and with interstices throughout it, through which interstices the steam and water may pass freely.

The upper chamber contains also a layer of coke, charcoal, or other filtering substances placed within it.

In connection with this condensing, purifying, and heating chamber, I employ means for supplying water to the boiler without the use of a pump, consisting of a drum or hot-water reservoir, J, placed between the chamber and the boiler, and connected with both by the water-pipes K H. From the steam space of chamber C a steam-pipe, M, admits steam under pressure within the upper part of the drum upon the hot water. Thus by shutting the cock *h* in the water-pipe H, and then opening the steam and water cocks *h m* in the pipes K M, respectively, the pressure will force the hot water into the boiler, thus feeding the water without pumping.

*Improvements in Feed-water Filters, &c.*

The chamber A A' is to be provided with the necessary water-level tubes, gauge-cock, man-holes, &c., for the proper operation of the apparatus, and to facilitate removing of the cobble stones for the purpose of cleaning, or to free the diaphragm from any incrustation which may have accumulated upon it. The bottom of the lower chamber has a discharge pipe, I, to permit the withdrawal of any sediment.

In the operation of my apparatus exhaust steam is introduced through the horizontal pipe G into the lower chamber, and by reason of its horizontal direction it is uniformly diffused, and, passing freely through the open bottom or diaphragm upon which the cobble stones rest, acts immediately and uniformly upon the mass, imparting to it directly its heat. By reason of the interstices between these irregular cobble stones it may pass freely up, heating the whole mass as it rises, maintaining the mass at a high temperature, and thence passing into the upper chamber, where it meets the feed-water showered from above. The feed-water receives from the steam its first increment of heat, and then falls upon the heated stones, which, by their high temperature, raise the water to a point where the incrusting material contained therein becomes insoluble, and is deposited upon the surface of the stones, where it incrusts. As the water passes down through the interstices of the mass all parts of it are exposed to the action of the stones by reason of the water passing in thin films through the said interstices and over the surfaces of the stones. As the stones are heated from the bottom, their action becomes more effective upon the water as it progresses downward.

The effect of this apparatus is manifestly twofold, as it at the same time frees the water from the materials which would form incrustations in the boiler, and imparts to it the heat of the exhaust steam, which would otherwise be wasted. Incidentally, also, it condenses part of the exhaust steam, and returns it to the boiler with the feed-water; but the main effect is that the hard, insoluble, heat-retaining surfaces of the stones, raised by the direct application of the steam to a high degree of heat, act instantly upon the thin films of water as they pass over said surfaces.

Desiring to be understood as admitting that the elements, so far as specified above, in the patents referred to are not new or of my invention, I make no claim thereto, and limit myself to the organization specified, made up of elements necessary to secure the perfect action of the steam of the heating surfaces and of the water.

What I do claim is,—

- 1.—An apparatus for purifying and heating feed-water, consisting of a chamber provided with a mass of stones, preferably cobble stones, supported on an open or wholly perforated diaphragm or grating, in combination with a feed-water pipe adapted to spray water on the upper surface of the mass of stones, and a steam-supply pipe in the lower part of the chamber, adapted to supply steam in a diffused state directly to the lower surface of the mass, as set forth.
- 2.—In combination with the chamber having the stone in mass, the open diaphragm, and the water-supply pipe, a steam-supply pipe adapted to discharge horizontally beneath said diaphragm, as set forth.
- 3.—The combination, in one vessel or apparatus, of the condensing and filtering chamber A, having a perforated diaphragm B, the water-spraying pipe E, the feed-water receiving chamber J, having the exhaust-steam inlet G located in the side thereof, and the boiler D and pipe K, arranged as shown, and for the purpose described.
- 4.—In a heater and purifier for steam-boilers, the vessel A A', having a removable or hinged top and steam outlet, a water-jet arranged within the vessel and under said top, a mass of cobble stones arranged under said jet and resting upon a diaphragm wholly perforated, and exhaust-steam inlet pipe G, entering horizontally below said diaphragm, and a funnel-bottomed chamber for the collection of any escaping sediment, all combined and arranged for joint operation, in the manner shown and set forth.

In witness whereof, the said Llewellyn Steam-condenser Manufacturing Company have hereto set their seal, this thirtieth day of November, one thousand eight hundred and eighty-two.

LLEWELLYN STEAM-CONDENSER MANUFACTURING COMPANY.

Witness—FRED. WALSH.  
Manager—EDWD. WATERS, Patent Office, Sydney.

By their Agent,  
PHILLIP DAVIES.

This is the specification referred to in the annexed Letters of Registration granted to the Llewellyn Steam-condenser Manufacturing Company, this twelfth day of May, A.D. 1883.

AUGUSTUS LOFTUS.

---

*Improvements in Feed-water Filters, &c.*

---

REPORT.

---

Sir,

In accordance with your letter of the 5th December, we have examined the specification and plans attached to the application of the Llewellyn Steam-condenser Manufacturing Company, for provisional protection for an invention styled "Improvements in Feed-water Filters, Heaters, Purifiers, and Condensers for Steam-boilers," and have to report that we see no reason why the protection sought should not be granted.

Sydney, 4 December, 1882.

We have, &amp;c.,

JAMES BARNET.

WILLIAM C. BENNETT.

The Under Secretary of Justice.

---

[Drawings—one sheet.]

---

**No. 1234.**[Assignment of No. 557. See Letters of Registration for 1876, page 163.]

---

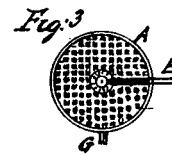
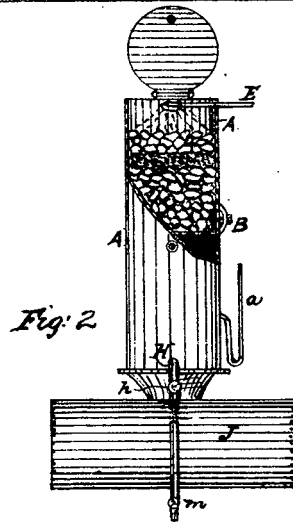
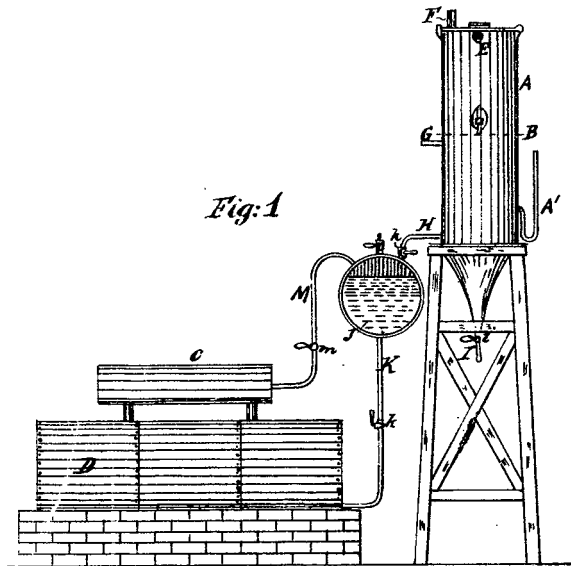
**No. 1235.**[Assignment of No. 557. See Letters of Registration for 1876, page 163.]

---

**No. 1236.**[Assignment of No. 1225. See Letters of Registration for 1883, page 141.]

---

*Llewellyn & Co's Patent.*



(57-55-1)

*This is the Sheet of Drawings referred to in the annexed  
Letters of Registration granted to the Llewellyn Steam  
Condenser Manufacturing Company this twelfth day of May A.D. 1883.*

*Augustus Loftus.*



A.D. 1883, 19th May. No. 1237.

AN IMPROVED METHOD OF CONVERTING HIDES AND SKINS INTO LEATHER.

LETTERS OF REGISTRATION to John Shaw, for an improved method of converting Hides and Skins into Leather.

[Registered on the 21st day of May, 1883, in pursuance of the Act 16 Vic. No. 24.]

BY HIS EXCELLENCY THE RIGHT HONORABLE SIR AUGUSTUS WILLIAM FREDERICK SPENCER LOFTUS (commonly called LORD AUGUSTUS LOFTUS), Knight Grand Cross of the Most Honorable Order of the Bath, a Member of Her Majesty's Most Honorable Privy Council, Governor and Commander-in-Chief of the Colony of New South Wales and its Dependencies.

TO ALL TO WHOM THESE PRESENTS SHALL COME, greeting :

WHEREAS JOHN SHAW, of Hindmarsh, near Adelaide, in the Province of South Australia, fellmonger, hath by his Petition humbly represented to me that he is the author or designer of a certain invention or improvement in manufactures, that is to say, of an invention entitled "An improved method of converting Hides and Skins into Leather," which is more particularly described in the amended specification which is hereunto annexed ; and that he, the said Petitioner, hath deposited with the Honorable the Treasurer of the said Colony of New South Wales the sum of Twenty Pounds sterling, for defraying the expense of granting these Letters of Registration, as required by the Act of Council, sixteenth Victoria, number twenty-four ; and hath humbly prayed that I would be pleased to grant Letters of Registration, whereby the exclusive enjoyment and advantage of the said invention or improvement might be secured to him for a period of fourteen years : And I, being willing to give encouragement to all inventions and improvements in the arts or manufactures which may be for the public good, and having received a report favourable to the prayer of the said Petition, from competent persons appointed by me to examine and consider the matters stated therein and to report thereon for my information, am pleased, with the advice of the Executive Council, and in exercise of the power and authority given to me by the said Act of Council, to grant, and do by these Letters of Registration grant unto the said John Shaw, his executors, administrators, and assigns, the exclusive enjoyment and advantage of the said invention or improvement, for and during the term of fourteen years from the date hereof ; to have, hold, and exercise unto the said John Shaw, his executors, administrators, and assigns, the exclusive enjoyment and advantage thereof, for and during and unto the full end and term of fourteen years from the date of these presents next and immediately ensuing, and fully to be complete and ended : Provided always, that if the said John Shaw shall not, within three days after the granting of these Letters of Registration, register the same in the proper office in the Supreme Court, at Sydney, in the said Colony of New South Wales, then these Letters of Registration, and all advantages whatsoever hereby granted, shall cease and become void.

In witness whereof, I have hereunto set my sign manual, and have caused the present Letters of Registration to be sealed with the seal of the said Colony of New South Wales, at Government House, Sydney, in New South Wales, this nineteenth day of May, in the year of our Lord one thousand eight hundred and eighty-three.

[L.S.]

AUGUSTUS LOFTUS.

*An improved method of converting Hides and Skins into Leather.*

SPECIFICATION of JOHN SHAW, of Hindmarsh, near Adelaide, in the Province of South Australia, fellmonger, for an invention entitled "An improved method of converting Hides and Skins into Leather."

THIS invention of an improved method of converting hides and skins into leather consists in the employment of carbolic acid, or sulpho-carbolic acid, or salicylic acid, or their various compounds, as a substitute for the tannic acid extracted from the barks now used in the process of tanning. The use of these novel materials reduces the time and labour spent in such process.

I have found by practice that by mixing these novel ingredients with animal, vegetable, and mineral oils and fats, bisulphide of carbon, acetic acid, alcohol, methylated alcohol, glycerine, water, solutions of the alkalies, solutions of soap, bran, flour, glucose, or sugar, a suitable solution for penetrating the substance of the hide and skin is formed. The ingredients may be used simply or combined together, as may be found most advantageous, as although the introduction of the carbolic acid, sulpho-carbolic acid, salicylic acid, or their compounds, into the substance of the hide or skin converts them into leather, with a large saving of time and labour compared with the processes now in use, yet the quality of the leather is influenced by the medium used in the process, so that it is better to use a different solution for the various classes of leather, thus:—

For preparing a hard heavy leather suitable for soles or for belting purposes, I employ a medium consisting of (say) ten gallons of water and one pound of soap with three pints of carbolic acid, adding fresh acid from day to day until the hides or skins are converted into leather.

For the softer kinds of leather I employ a medium consisting of (say) four parts of any of the animal or vegetable oils with one part of carbolic acid, and allow the hides or skins to remain in this compound for (say) from twenty-four to forty-eight hours, after which they are removed and placed in a mixture consisting of four parts of bisulphide of carbon and one part of carbolic acid, where they are allowed to remain for from two to twelve hours, when the operation is completed.

Other proportions might of course be used, but these I have found to be the most economical in practice.

Both previous to and during the operation of converting hides or skins into leather they are manipulated in identically the same manner as in the tanning processes now in use, save and except that instead of the usual solution or decoction of the various barks or other tanning materials now in use I use a solution containing carbolic acid, or sulpho-carbolic acid, or salicylic acid, and preferably one or other of the solutions just before described.

Having thus described my said invention, and the manner in which the same is to be put into operation, I would have it understood that I do not claim the use of any of the ingredients mentioned, save and except as a portion of a medium for converting hides and skins into leather; but what I do claim as,—

My improved method of converting hides and skins into leather is the employment of carbolic acid (phenylic alcohol), or sulpho-carbolic acid, or salicylic acid, or any compound containing carbolic acid, in combination with any fluid or medium to form a tanning fluid (or medium which will convert hides and skins into leather), substantially as herein described and explained.

EDWD. WATERS,  
Agent for Applicant.

This is the amended specification referred in the annexed Letters of Registration granted to John Shaw, this nineteenth day of May, A.D. 1883.

AUGUSTUS LOFTUS.

---

**REPORTS.**


---

Sir,

In reply to your blank-cover communication, 22nd instant, No. 13,228, we have the honor to report that we are of opinion that the claim set forth by Mr. John Shaw for "An improved method of converting Hides and Skins into Leather," is too wide and indefinite to enable us to recommend its registration; it should have specified the exact proportions of the ingredients he proposes to apply in his process for tanning.

Sydney, 30 November, 1882.  
We have, &c.,

EDMUND FOSBERY.  
GOTHER K. MANN.

The Under Secretary of Justice.

Sir,

In returning your further B.C. reference respecting Mr. John Shaw's application for Letters of Registration for "An improved method of converting Hides and Skins into Leather," we have to report that we still see difficulties in the way of granting the application in its present vague form, and consider that the specification of the claim should be altered and made more definite. Carbolic acid is at present in use for preserving hides for tanning. Mr. Shaw proposes to use it with other acids for converting hides and skins into leather, and he should therefore specify more definitely the mode of application and the process.

Sydney, 9 January, 1883.

We fail to see how this could be injurious to his interests.

We have, &c.,

EDMUND FOSBERY.  
GOTHER K. MANN.

Sir,

We do ourselves the honor to report, in reply to your blank-cover of the 7th instant, No. 2,815, transmitting Mr. John Shaw's revised specification and claim for "An improved method of converting Hides and Skins into Leather," that we are of opinion the prayer of the Petitioner may now be granted.

Sydney, 13 March, 1883.

We have, &c.,

EDMUND FOSBERY.  
GOTHER K. MANN.

The Under Secretary of Justice.

---




---

A.D. 1883, 19th May. No. 1238.

---

**AN IMPROVED PROCESS OF EXTRACTING THE OXIDES OF COBALT AND  
MANGANESE FROM THEIR ORES.**

---

LETTERS OF REGISTRATION, to Henri Herrenschmidt and Marmaduke Constable, for an improved process of extracting the Oxides of Cobalt and Manganese from their Ores.

[Registered on the 21st day of May, 1883, in pursuance of Act 16 Vic. No. 24.]

---

BY HIS EXCELLENCY THE RIGHT HONORABLE SIR AUGUSTUS WILLIAM FREDERICK SPENCER LOFTUS (commonly called LORD AUGUSTUS LOFTUS), Knight Grand Cross of the Most Honorable Order of the Bath, a Member of Her Majesty's Most Honorable Privy Council, Governor and Commander-in-Chief of the Colony of New South Wales and its Dependencies.

TO ALL TO WHOM THESE PRESENTS SHALL COME, greeting :

WHEREAS HENRI HERRENSCHMIDT, metallurgist, and MARMADUKE CONSTABLE, gentleman, both of Sydney, in the Colony of New South Wales, hath by their Petition humbly represented to me that they are the authors or designers of a certain invention or improvement in manufactures, that is to say, of an invention entitled "An improved process of extracting the Oxides of Cobalt and Manganese from their Ores," which is more particularly described in the specification which is hereunto annexed; and that they, the said Petitioners, have deposited with the Honorable the Treasurer of the said Colony of New South Wales the sum of Twenty Pounds sterling for defraying the expense of granting these Letters of Registration, as required by the Act of Council, sixteenth Victoria, number twenty-four; and have humbly prayed that I would be pleased to grant Letters of Registration, whereby the exclusive enjoyment and advantage of the said invention or improvement might be secured to them for a period of fourteen years: And I, being willing to give encouragement to all inventions and improvements in the arts or manufactures which may be for the public good, and having received a report favourable to the prayer of the said Petition, from competent persons appointed by me to examine and consider the matters stated therein and to report thereon for my information, am pleased, with the advice of the Executive Council, and in exercise of the power and authority given to me by the said Act of Council, to grant, and do by these Letters of Registration grant unto the said Henri Herrenschmidt and Marmaduke Constable, their executors, administrators, and assigns, the exclusive enjoyment and advantage of the said invention or improvement for and during the term of fourteen years from the date hereof; to have, hold, and exercise unto the said Henri Herrenschmidt and Marmaduke Constable, their executors, administrators, and assigns, the exclusive enjoyment and advantage thereof, for and during and unto the full end and term of fourteen years from the date of these presents next and immediately ensuing, and fully to be complete and ended: Provided always, that if the said Henri Herrenschmidt and Marmaduke Constable shall not, within three days after the granting of these Letters of Registration, register the same in the proper office in the Supreme Court, at Sydney, in the said Colony of New South Wales, then these Letters of Registration, and all advantages whatsoever hereby granted, shall cease and become void.

In witness whereof, I have hereunto set my sign manual, and have caused the present Letters of Registration to be sealed with the seal of the said Colony of New South Wales, at Government House, Sydney, in New South Wales, this nineteenth day of May, in the year of our Lord one thousand eight hundred and eighty-three.

[L.S.]

AUGUSTUS LOFTUS.

---

*An improved process of extracting Oxides of Cobalt and Manganese from their Ores.*

SPECIFICATION of HENRI HERRENSCHMIDT, metallurgist, and MARMADUKE CONSTABLE, gentleman, both of Sydney, in the Colony of New South Wales, for an invention entitled "An improved process of extracting the Oxides of Cobalt and Manganese from their Ores."

OUR invention consists in the use of sulphate of iron, or any substance or compound which will form sulphate of iron, for the purpose of extracting the oxides of cobalt and manganese from their ores, in the form of sulphates, in which form they are easily converted into oxides by old and well-known processes. The theory of our process is to decompose the sulphate of iron in the presence of the ores containing the oxides of cobalt and manganese, or either of them, so that the sulphate of iron can be converted into oxide of iron, and the oxides of cobalt and manganese into sulphates, in which condition the sulphates are washed out and reconverted into oxides.

In practice we prefer the following mode of procedure:—The ore must first be crushed or ground very fine, and its percentage of oxides of cobalt and manganese ascertained. We then add sufficient sulphate of iron to convert the said oxides into sulphates. The ore, if not wet crushed, should have sufficient water added to it to make it into a slime. In this condition we boil it for half an hour in any suitable vessel, by which time the whole of the oxides will have been converted into sulphates and held in solution by the liquor in which the slime has been boiled. We therefore decant this solution and wash the thick residue of all remaining solution, so as to remove all trace of said sulphates, and these solutions we then treat with any of the well-known materials for reconverting said sulphates into oxides.

If the slime is put into cold water and allowed to remain there say for twenty-four hours, the most of the oxides will have been converted into sulphates; but this makes the process tedious, and is not so efficacious as when the slime is boiled.

Again, instead of boiling, the sulphate of iron, in the shape of a salt, may be mixed with the dry crushed ore and heated in a furnace until the double decomposition above referred to has taken place, that is, until the sulphate of iron has been converted into an oxide of iron, and the oxides of cobalt and manganese into sulphates of the same. These sulphates may then be washed out with cold water and precipitated in the form of oxides, as before.

Having thus described the nature of our invention, and the manner of performing same, we would have it understood that our process only relates to the extraction of the oxides of cobalt and manganese from their ores, in the form of sulphates, in which form they are easily convertible into oxides by old and well-known chemical processes. What we believe to be new, and therefore claim as our invention, is,—

The use of sulphate of iron, or any substance or compound which will form sulphate of iron, for the purpose of extracting the oxides of cobalt and manganese from their ores, in the manner substantially as herein described and explained.

In witness whereof, we have hereto set our hands.

HENRI HERRENSCHMIDT.  
By his Agent, FRED. WALSH.  
MARMADUKE CONSTABLE.

EDWD. WATERS, Agent for Applicants.

This is the specification referred to in the annexed Letters of Registration granted to Henri Herrenschmidt and Marmaduke Constable, this nineteenth day of May, A.D. 1883.

AUGUSTUS LOFTUS.

### REPORTS.

Sir,

Sydney, 6 February, 1883.

The application of Messrs. Henri Herrenschmidt and Marmaduke Constable, for Letters of Registration for an invention entitled "Process for extracting Cobalt or Manganese from their Ores, or Cobalt from Ores containing Manganese, as found in New Caledonia," having been referred to us, we have examined the specification accompanying the same, and have now the honor to report that we see no objection to the issue of Letters of Registration as prayed for.

We deem it right to draw attention to the use in the specification of the words "lissivated" and "lissivation," which we take to be intended for "lixiviated" and "lixiviation," and an opportunity might perhaps be given to the Petitioners to make these corrections.

We have, &c.,  
A. LEIBIUS.  
CHAS. WATT.

The Under Secretary of Justice.

Sir,

Sydney, 6 March, 1883.

We have the honor to return herewith the papers connected with an application of Messrs. Henri Herrenschmidt and Marmaduke Constable to be permitted to substitute a more definite specification, and also to alter the title of their invention to "An improved process of extracting the Oxides of Cobalt and Manganese from their Ores," and to report that we see no objection to the request being granted.

We beg to mention that the original specification has not been returned to us with the above papers, as is the usual custom to do.

We have, &c.,  
A. LEIBIUS.  
CHAS. WATT.

The Under Secretary of Justice.





A.D. 1883, 19th May. No. 1239.

THE PORTABLE HYGIENIC BATH.

LETTERS OF REGISTRATION to King David Sykes, for an invention entitled  
"The Portable Hygienic Bath."

[Registered on the 21st day of May, 1883, in pursuance of the Act 16 Vic. No. 24.]

BY HIS EXCELLENCY THE RIGHT HONORABLE SIR AUGUSTUS WILLIAM FREDERICK SPENCER LOFTUS (commonly called LORD AUGUSTUS LOFTUS), Knight Grand Cross of the Most Honorable Order of the Bath, a Member of Her Majesty's Most Honorable Privy Council, Governor and Commander-in-Chief of the Colony of New South Wales and its Dependencies.

TO ALL TO WHOM THESE PRESENTS SHALL COME, greeting:

WHEREAS KING DAVID SYKES, of Christchurch, in the Colony of New Zealand, hath by his Petition humbly represented to me that he is the author or designer of a certain invention or improvement in manufactures, that is to say, of an invention entitled "The Portable Hygienic Bath," which is more particularly described in the specification and the sheet of drawings which are hereunto annexed; and that he, the said Petitioner, had deposited with the Honorable the Treasurer of the said Colony of New South Wales the sum of Twenty Pounds sterling, for defraying the expense of granting these Letters of Registration, as required by the Act of Council, sixteenth Victoria, number twenty-four, and hath humbly prayed that I would be pleased to grant Letters of Registration whereby the exclusive enjoyment and advantage of the said invention or improvement might be secured to him for a period of fourteen years: And I, being willing to give encouragement to all inventions and improvements in the arts or manufactures which may be for the public good, and having received a report favourable to the prayer of the said Petition from competent persons appointed by me to examine and consider the matters stated therein and to report thereon for my information, am pleased, with the advice of the Executive Council, and in exercise of the power and authority given to me by the said Act of Council, to grant, and do by these Letters of Registration grant, unto the said King David Sykes, his executors, administrators, and assigns, the exclusive enjoyment and advantage of the said invention or improvement, for and during the term of fourteen years from the date hereof; to have, hold, and exercise unto the said King David Sykes, his executors, administrators, and assigns, the exclusive enjoyment and advantage thereof, for and during and unto the full end and term of fourteen years from the date of these presents next and immediately ensuing, and fully to be complete and ended: Provided always, that if the said King David Sykes shall not, within three days after the granting of these Letters of Registration, register the same in the proper office in the Supreme Court, at Sydney, in the said Colony of New South Wales, then these Letters of Registration, and all advantages whatsoever hereby granted, shall cease and become void.

In witness whereof, I have hereunto set my sign manual, and have caused the present Letters of Registration to be sealed with the seal of the said Colony of New South Wales, at Government House, Sydney, in New South Wales, this nineteenth day of May, in the year of our Lord one thousand eight hundred and eighty-three.

[L.S.]

AUGUSTUS LOFTUS.

*The Portable Hygienic Bath.*

## PORTABLE HYGIENIC BATH.

THIS invention is a method by which all the benefits of hot-air baths, either dry or vaporised, plain or medicated, can be obtained by a convenient and portable apparatus.

The bath is constructed of wood, and fitted with metallic air-heaters and shield plates.

Fig. 1 shows the bath closed and out of use. The parts C and D are hinged, or otherwise movable; the part E is removable, and when the bath is in use is replaced by the part F, through the aperture in which the head of the patient projects.

Fig. 2 is a section showing the arrangements for heating and circulating the air. The heat is supplied by four methylated spirit lamps of any convenient construction, two at the head, and two at the feet. The lamps may be placed in any convenient position, but I prefer two to be under the seat, and the others under the foot-board. An air-heater, of the form shown in figs. 5 and 6, is used over the lamps. Their use is to heat and distribute the current of air entering by the apertures A A, or other similar apertures, over a metallic heating surface, and discharge it through the interior of the bath. Slides B B regulate the amount of air required to feed the lamps and keep up the desired temperature. The products of combustion are carried off by the funnel G, the draught of which is regulated by the ventilating slide.

## CLAIM.

The method by which the products of combustion are circulated in the bath, and carried off by the funnel, and the method, as shown by figs. 5 and 6, by which the pure air is heated, and circulated within the bath, the whole being applied to a portable apparatus, and not, as hitherto done, fixed structures. The form of heater, as shown in figs. 5 and 6, is claimed as applicable to any structures fixed or portable.

This is the specification referred to in the annexed Letters of Registration granted to King David Sykes, this 19th day of May, A.D. 1883.

AUGUSTUS LOFTUS.

## REPORT.

Sir,

The application of Mr. K. D. Sykes for Letters of Registration for an invention entitled "The Portable Hygienic Bath," having been referred to us, we have examined the plans and specification accompanying the same, and have now the honor to report that we see no objection to the issue of Letters of Registration as prayed for.

We have, &c.,

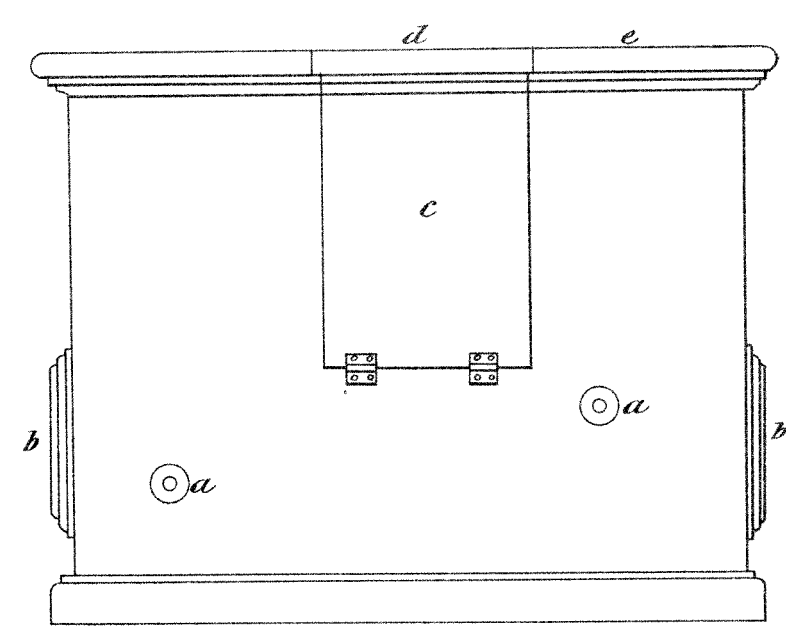
JAMES BARNET.

EDMUND FOSBERY.

The Under Secretary of Justice.

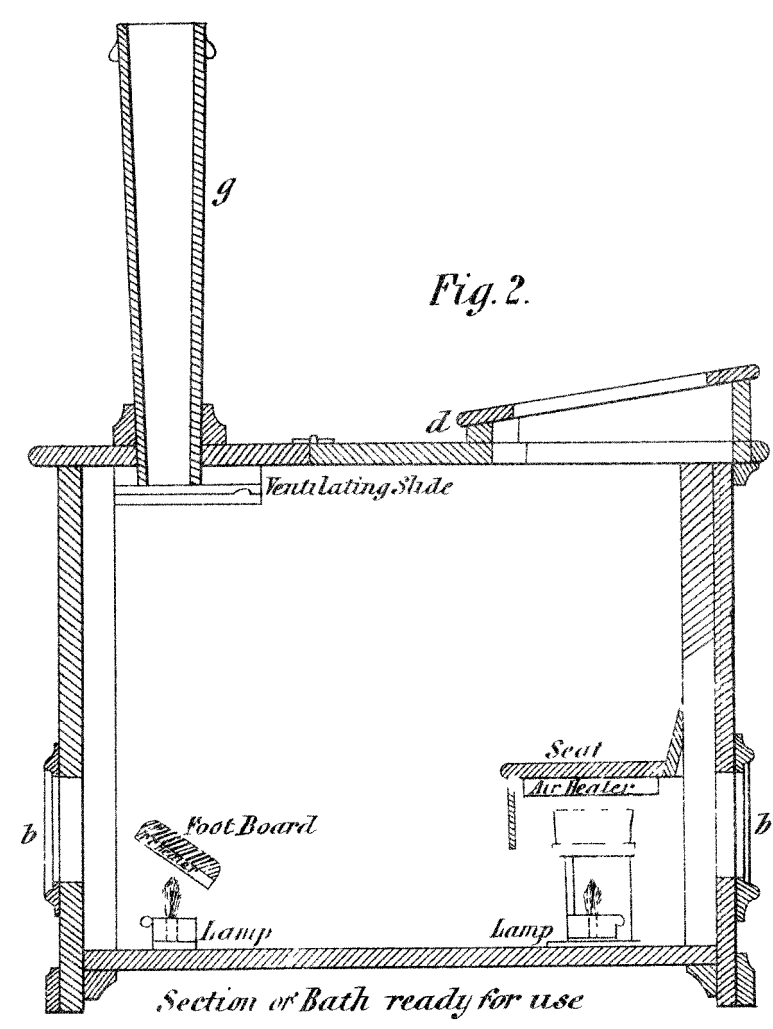
[Drawings - one sheet.]

Fig. 1.



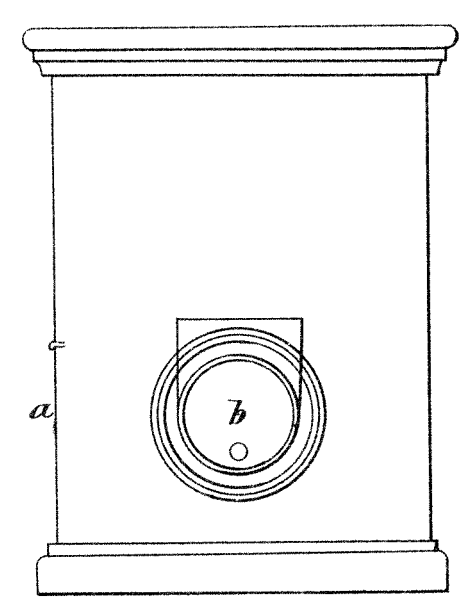
Elevation of Bath not in use.

Fig. 2.



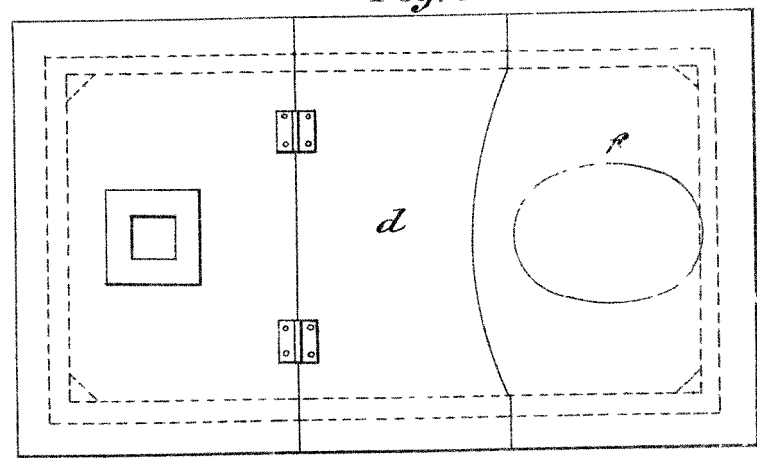
Section of Bath ready for use

Fig. 3.



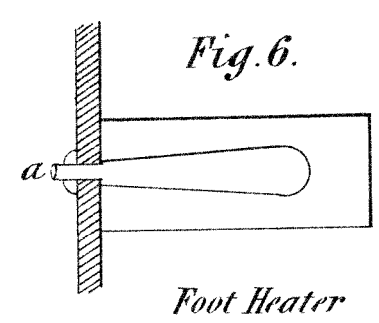
End Elevation of Bath

Fig. 4.



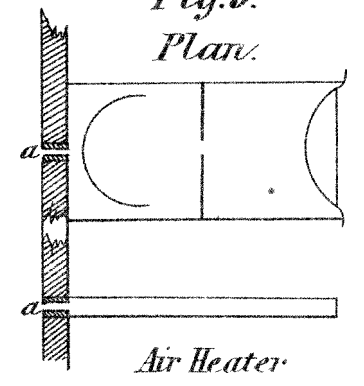
Plan of Top of Bath

Fig. 6.



Foot Heater

Fig. 5.



Air Heater

This is the Sheet of Drawings referred to in the annexed  
 Letters of Registration granted to King David Sykes, this  
 19<sup>th</sup> day of May, A.D. 1883  
 Augustus Loftus.



A.D. 1883, 19th May. No. 1240.

IMPROVEMENTS IN ROPE TRACTION RAILWAYS AND TRAMWAYS.

LETTERS OF REGISTRATION to Charles Farquhar Findlay, for Improvements in Rope Traction Railways and Tramways.

[Registered on the 21st day of May, 1883, in pursuance of the Act 16 Vic. No. 24.]

BY HIS EXCELLENCY THE RIGHT HONORABLE SIR AUGUSTUS WILLIAM FREDERICK SPENCER LOFTUS (commonly called LORD AUGUSTUS LOFTUS), Knight Grand Cross of the Most Honorable Order of the Bath, a Member of Her Majesty's Most Honorable Privy Council, Governor and Commander-in-Chief of the Colony of New South Wales and its Dependencies.

TO ALL TO WHOM THESE PRESENTS SHALL COME, greeting:

WHEREAS CHARLES FARQUHAR FINDLAY, of Number 7, Mecklenburgh-street, in the County of Middlesex, England, civil engineer, hath by his Petition humbly represented to me that he is the author or designer of a certain invention or improvement in manufactures, that is to say, of an invention entitled "Improvements in Rope Traction Railways and Tramways," which is more particularly described in the specification marked "A," and the two sheets of drawings marked "B" and "C" respectively, which are hereunto annexed; and that he, the said Petitioner, hath deposited with the Honorable the Treasurer of the said Colony of New South Wales the sum of Twenty Pounds sterling, for defraying the expense of granting these Letters of Registration, as required by the Act of Council, sixteenth Victoria, number twenty-four; and hath humbly prayed that I would be pleased to grant Letters of Registration, whereby the exclusive enjoyment and advantage of the said invention or improvement might be secured to him for a period of fourteen years: And I, being willing to give encouragement to all inventions and improvements in the arts or manufactures which may be for the public good, and having received a report favourable to the prayer of the said Petition, from competent persons appointed by me to examine and consider the matters stated therein and to report thereon for my information, am pleased, with the advice of the Executive Council, and in exercise of the power and authority given to me by the said Act of Council, to grant, and do by these Letters of Registration grant unto the said Charles Farquhar Findlay, his executors, administrators, and assigns, the exclusive enjoyment and advantage of the said invention or improvement, for and during the term of fourteen years from the date hereof; to have, hold, and exercise unto the said Charles Farquhar Findlay, his executors, administrators, and assigns, the exclusive enjoyment and advantage thereof, for and during and unto the full end and term of fourteen years from the date of these presents next and immediately ensuing, and fully to be complete and ended: Provided always, that if the said Charles Farquhar Findlay shall not, within three days after the granting of these Letters of Registration, register the same in the proper office in the Supreme Court, at Sydney, in the said Colony of New South Wales, then these Letters of Registration, and all advantages whatsoever hereby granted, shall cease and become void.

In witness whereof, I have hereunto set my sign manual, and have caused the present Letters of Registration to be sealed with the seal of the said Colony of New South Wales, at Government House, Sydney, in New South Wales, this nineteenth day of May, in the year of our Lord one thousand eight hundred and eighty-three.

[L.s.]

AUGUSTUS LOFTUS.

*Improvements in Rope Traction Railways and Tramways.*

A.

SPECIFICATION of CHARLES FARQUHAR FINDLAY, of No. 7, Mecklenburgh-street, in the County of Middlesex, England, for an invention entitled "Improvements in Rope Traction Railways or Tramways."

MY invention relates to railways or tramways of that kind in which a rope travelling along a channel under the level of the road is taken hold of by gripping apparatus, extending down from the vehicle through a continuous slit of the rope channels, so that the vehicle is caused to travel along with the rope. According to my invention, I employ duplicate ropes travelling in the one channel, so that generally the strain of traction is divided over both, and in case of accident to one the other remains available for working the line. For the two ropes I provide suitable guide pulleys and tightening apparatus and gripping apparatus, whereby either rope can be taken hold of; and I construct the channel in which the ropes travel with appliances for supporting the track and for guiding the vehicles, so that the flanges of their wheels and the grooving of the rails can be dispensed with.

I will describe the construction and arrangement of these parts referring to the accompanying drawings. Fig. 1 shows one construction of the metal work for the rope channel. It consists of two similar castings, A A, bolted to a cross-beam, B, the castings A being made with shoes at *a a*, to receive the bearers for the track, and having bolted on their inner edges continuous cheeks C, between which is the slot for passage of the connections to the vehicles. These cheeks are steadied by diagonal ties *c c*. Another form of channel is shown in section by fig. 1<sup>a</sup>, the casting constituting one side of it being shown in plan at fig. 2<sup>a</sup>. In this case the cheek C, which constitutes one side of the slot, is cast in one piece with one of the brackets A, which project laterally to carry the track, and which are secured on the masonry by bolts *b b*. Below the slot the cheeks C form guides C<sup>1</sup>, for rollers E, which are mounted on vertical axes on the gripping apparatus or vehicle. These guide rollers suffice to keep the vehicle in the track, and consequently flat rails and wheels without flanges may be employed. Fig. 1<sup>b</sup> is a section, and fig. 2<sup>b</sup> a plan, showing another construction of the rope channel, according to which the brackets A are continued downwards in curved form, and are bolted together below the channel. Obviously the channel may be otherwise constructed, and the guides for the rollers E may be simply rails, C<sup>1</sup>, fixed at the sides of the channel, as shown in fig. 1<sup>c</sup>, which is a section representing a channel with the pulleys for the duplicate ropes arranged therein, as shown in the plan fig. 2<sup>c</sup>. In these figures *a<sup>1</sup> a<sup>2</sup>* are two ropes, each guided on pulleys *e*, which are flanged only on the one side, that is to say, the side farthest from the middle line of the channel. In some cases it is necessary to transmit power to a distance by a travelling rope. For this purpose there may be mounted in the channel additional guide pulleys, *ff*, carrying small ropes, *gg*, travelling at high speed, so as to convey power to any point along the line. It is of advantage to mount some of the pulleys *e* on arms, as shown in fig. 3, so that in case of the rope having been let go from the gripping apparatus the pulley may be raised by hooking up its arm, as indicated by the dotted lines, thus raising the rope, so that it can again be taken hold of by the gripping apparatus.

At curves of the line I provide for guiding the two traction ropes *a<sup>1</sup> a<sup>2</sup>*, as shown in plan at fig. 4, and in section at fig. 5. The pulleys *h<sup>1</sup> h<sup>2</sup>* are so placed as to carry the one rope, *a<sup>1</sup>*, at a higher level than the other, *a<sup>2</sup>*, and there are two horizontal pulleys of which I<sup>1</sup> is at a higher level than the other, I<sup>2</sup>. On the spindle of I<sup>1</sup> is loosely fitted a pulley, *i*, having a shallow helical groove, so that when the rope *a<sup>1</sup>* is raised by the gripping apparatus G above its ordinary level it becomes engaged in the helical groove of *i*<sup>1</sup>, and is guided down to its proper place on the surface of I<sup>1</sup>, which is a little less in diameter than *i*<sup>1</sup>. The pulley I<sup>2</sup> is formed in its upper parts as a fusee, that is to say, having a combined volute and helical form, so that when the rope *a<sup>2</sup>* is raised by G it is guided down the fusee part of I<sup>2</sup> to its proper place on its lower periphery.

Fig. 6 is a plan, and fig. 7 a longitudinal section, showing how the two outgoing and returning ropes are guided from the engine-house to the tracks, and showing also the elevating sheaves R, by which the rope is raised to be within range of the gripping apparatus G. The elevating sheaves R are mounted in frames S, which can rock on shafts T, as shown in fig. 8, and the upper and inner edge of each frame S is rounded, as shown in the plan fig. 9, so that the gripping apparatus in entering between the frames pushes them gently aside until it has passed them, whereupon they are returned by their weights to the position shown in fig. 8, where the frames rest against a stop, W. For the purpose of tightening the traction ropes, it is of advantage to subject the tightening pulley to a strain, increasing as it advances. This I effect by connecting the frame of the tightening pulley by a chain to a number of separate weights, each of which is suspended by chains from the next above it. Thus, as the pulley is drawn forwards it becomes subject to an increasing load. Instead of thus employing varying weights, a constant weight may be made to act with variable leverage, by suspending it from a fusee on the axis of the barrel, on which is wound the chain from the frame of the tightening pulley.

The gripping apparatus which I employ for holding the traction rope is shown in side view at fig. 10, a plan of its lower part, as seen from below, being shown by fig. 11. The hand lever I, by pressing down the bar M, grips the rope between it and base of the framing. I also employ another lever, N, which, through a bell crank, P, can move a horizontal slide, O. This slide works two vertical eccentric spindles carrying rollers Q Q, by moving which the rope is thrust laterally out of the grip. One of the eccentric spindles has fixed on it a cam-shaped arm, Y, which, when the vehicle reaches the terminus or place where the rope should be let go, meets a projection from the side of the tunnel, which, causing the eccentric spindle to turn partly round, throws the rope out of the grip.

I claim as my invention the following features of construction and arrangement for a rope traction line:—

1. The brackets A shown in fig. 1, bolted to the base B, having shoes *a* for the rails, and carrying the cheeks C of the slot, steadied by the tie-bolts *c*.
2. The modified construction shown in figs. 1<sup>a</sup> and 2<sup>a</sup>, according to which the brackets A, held down by the bolts B, have the cheeks C cast in one piece with them.
3. The modified construction shown in figs. 1<sup>b</sup> and 2<sup>b</sup>, according to which the brackets A are bolted together below the rope channel.
4. The arrangement, substantially as shown in figs. 1<sup>c</sup> and 2<sup>c</sup>, of guide pulleys for supporting duplicate traction ropes, with or without additional pulleys, carrying ropes for conveying power to a distance.

5.

*Improvements in Rope Traction Railways and Tramways.*

5. The arrangement shown in figs. 4 and 5, of helically grooved guide-roller *i*, and fusee guide-roller *I'*, for guiding duplicate traction ropes at a curve of the line.
6. The arrangement shown in figs. 6 and 7, for guiding the duplicate traction ropes to and from the driving engine.
7. The arrangement of the elevating sheaves on rocking frames, substantially as described with reference to figs. 8 and 9.
8. Increasing the strain on the tightening pulley as it advances by means of an increasing weight, or by means of a constant weight acting on a fusee.
9. In the gripping apparatus, the combination of lever *N*, slide *O*, and eccentric spindles and rollers *Q*, for throwing the traction rope out of the grip, as described with reference to figs. 11 and 12.
10. The use of lateral guide-rollers *E*, mounted on the gripping apparatus, or on a frame projecting down from the vehicle through the slot of the rope channel, these rollers bearing against the cheek of the slot or against rails in the channel, so as to guide the vehicle, thereby dispensing with flanges on the wheels and with grooved rails.

In witness whereof, I, the said Charles Farquhar Findlay, have hereunto set my hand and seal, this eleventh day of January, in the year of our Lord one thousand eight hundred and eighty-three.

CHARLES FARQUHAR FINDLAY.

Witness—OLIVER IMRAY.

This is the specification marked "A" referred to in the annexed Letters of Registration granted to Charles Farquhar Findlay, this nineteenth day of May, A.D. 1883.

AUGUSTUS LOFTUS.

---

REPORT.

---

Sir,

Having examined the drawings and specification accompanying the Petition, we have the honor to recommend that Letters of Registration should be issued to Mr. Charles Farquhar Findlay for an invention entitled "Improvements in Rope Traction Railways or Tramways," as shown in the drawings and described in the specification attached to his Petition.

Sydney, 10 March, 1883.  
We have, &c.,

JOHN WHITTON.  
E. O. MORIARTY.

The Under Secretary of Justice.

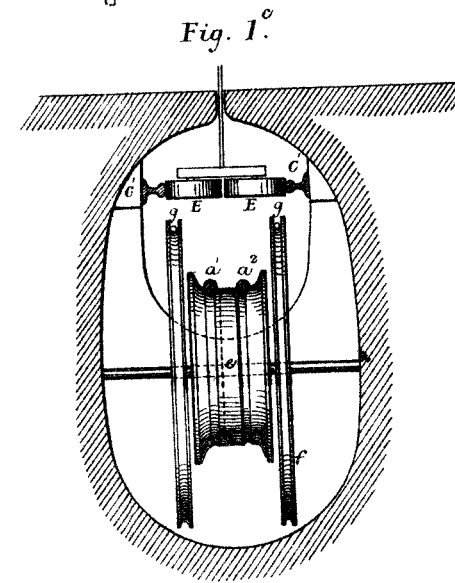
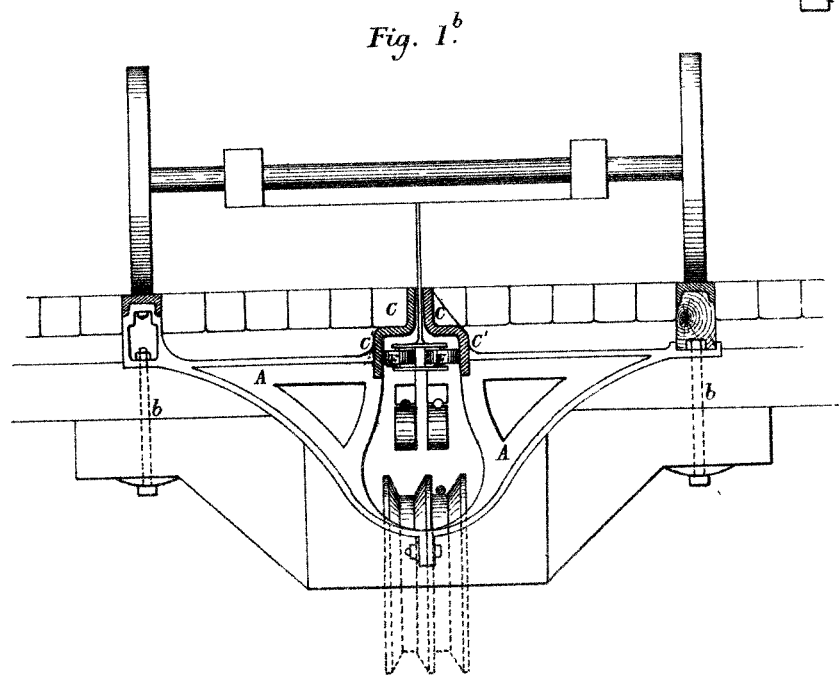
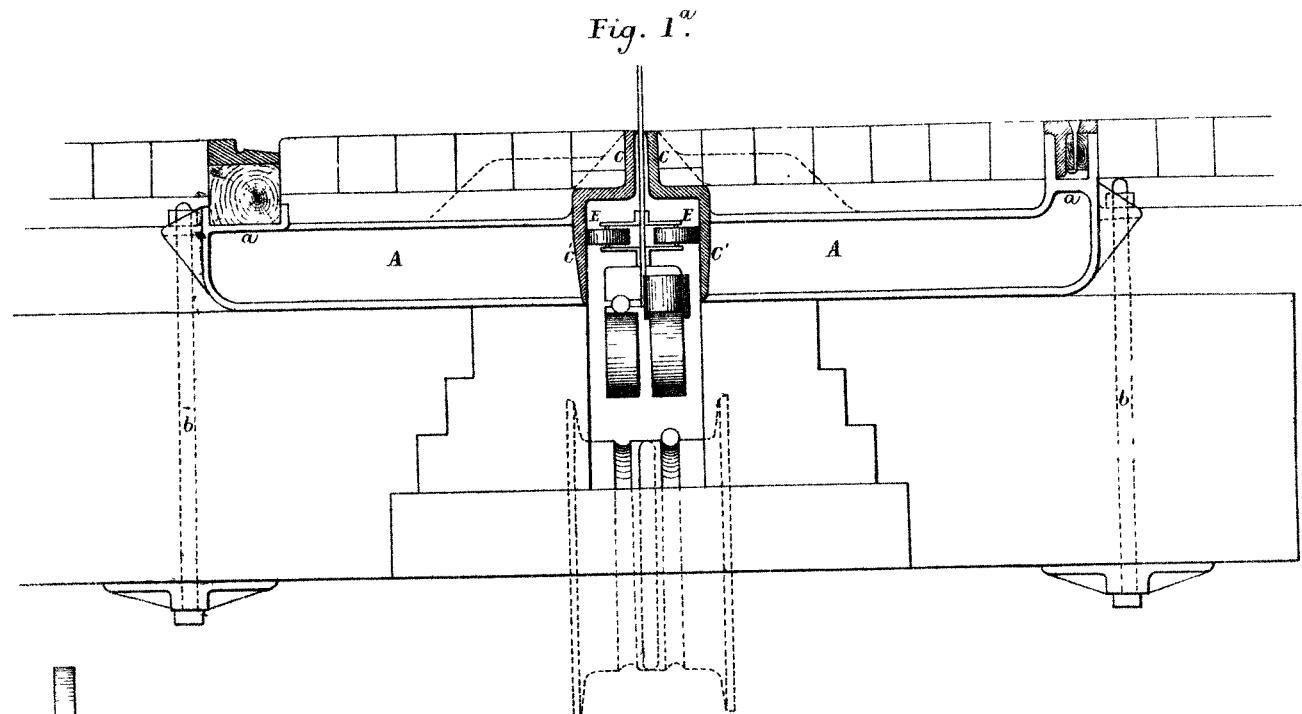
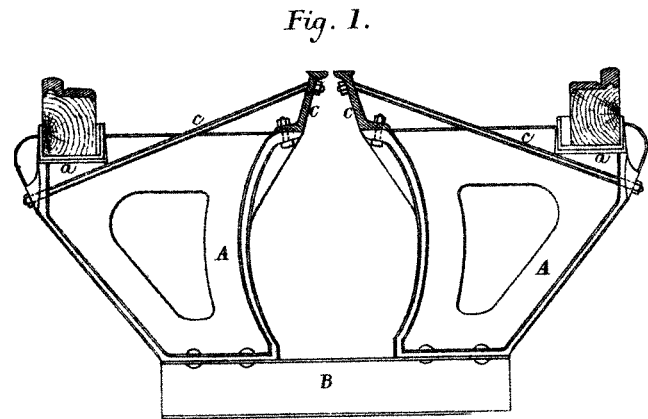
---

[Drawings—two sheets.]

---

No. 1241.

[Assignment of No. 853. See Letters of Registration for 1880, page 197.]



*This is the Sheet of Drawings marked B referred to in  
the annexed Letters of Registration granted to Charles  
Farquhar Findlay, this fifteenth day of May 1883.  
Augustus Loftus.*

Fig. 2<sup>a</sup>

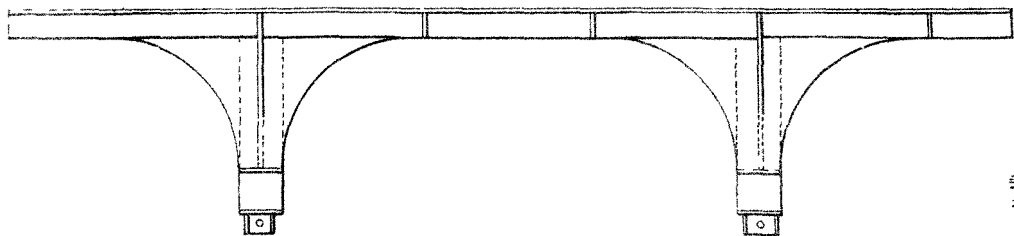


Fig. 2<sup>b</sup>

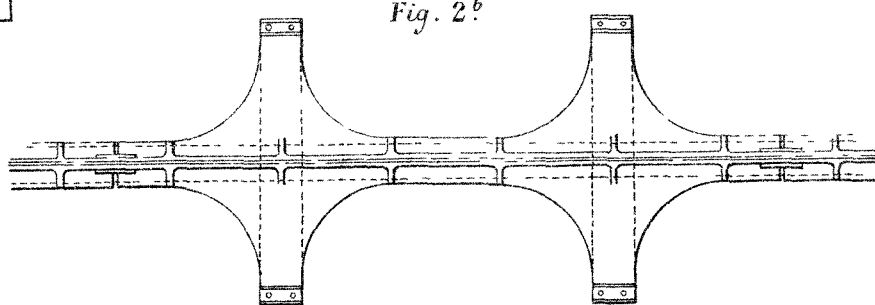


Fig. 2<sup>c</sup>

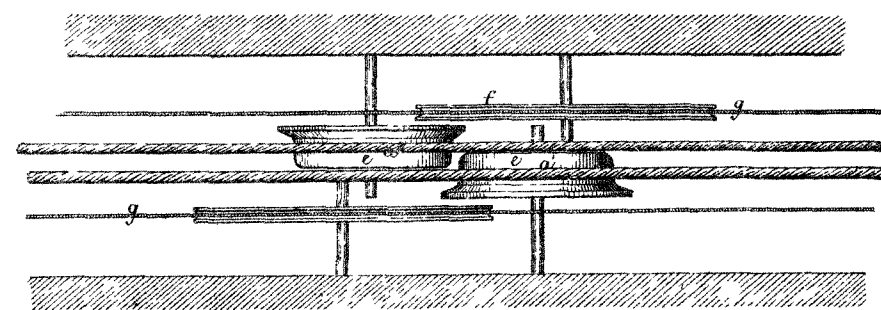


Fig. 3.

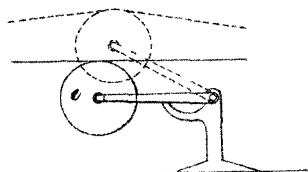


Fig. 6.

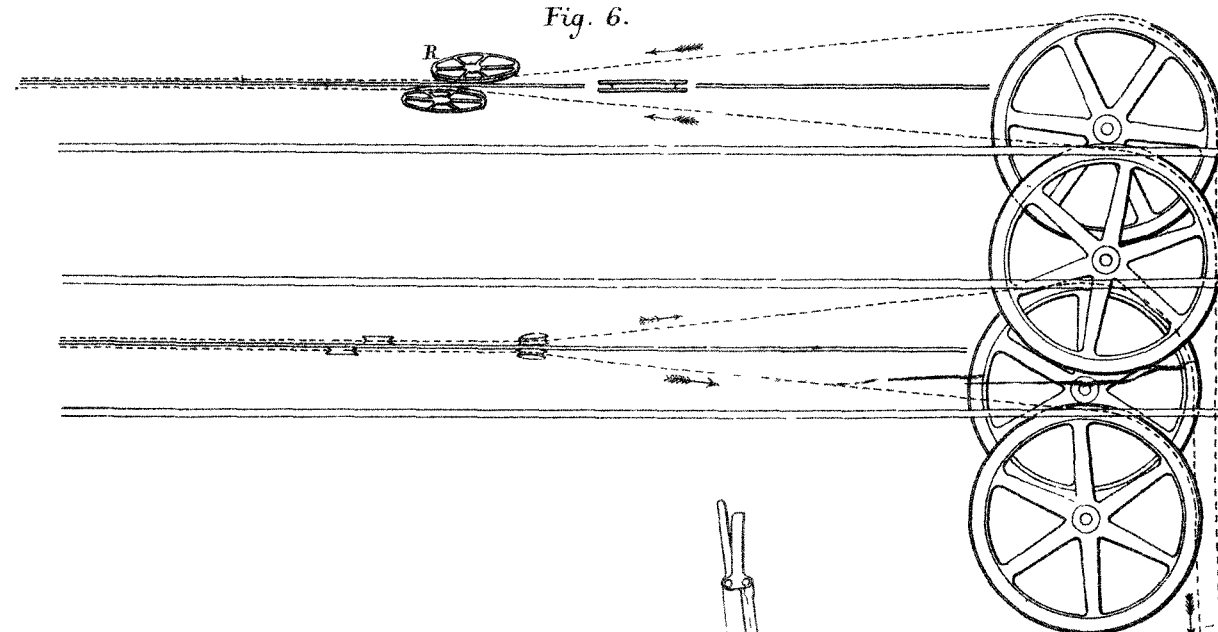


Fig. 5.

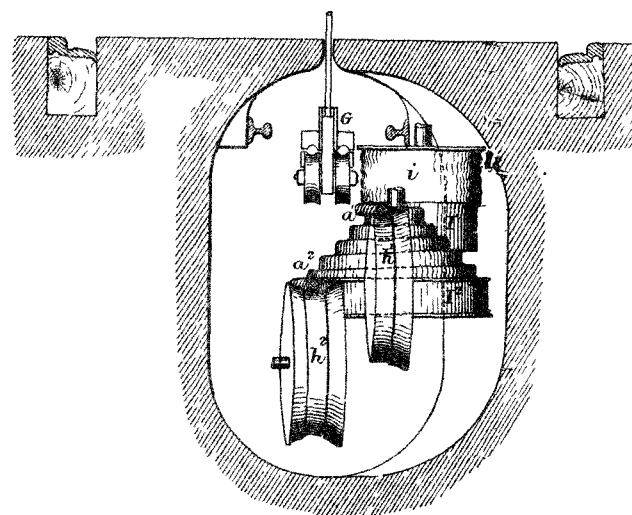


Fig. 4.

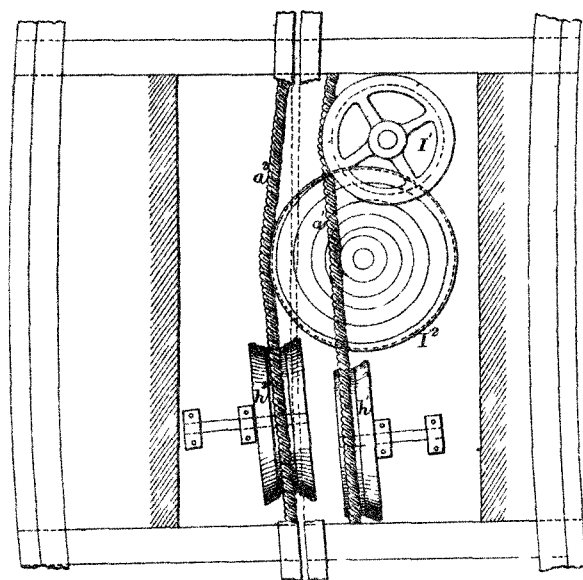


Fig. 11.

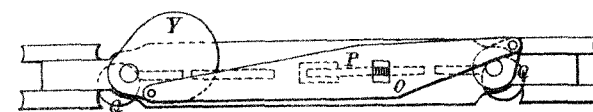


Fig. 10.

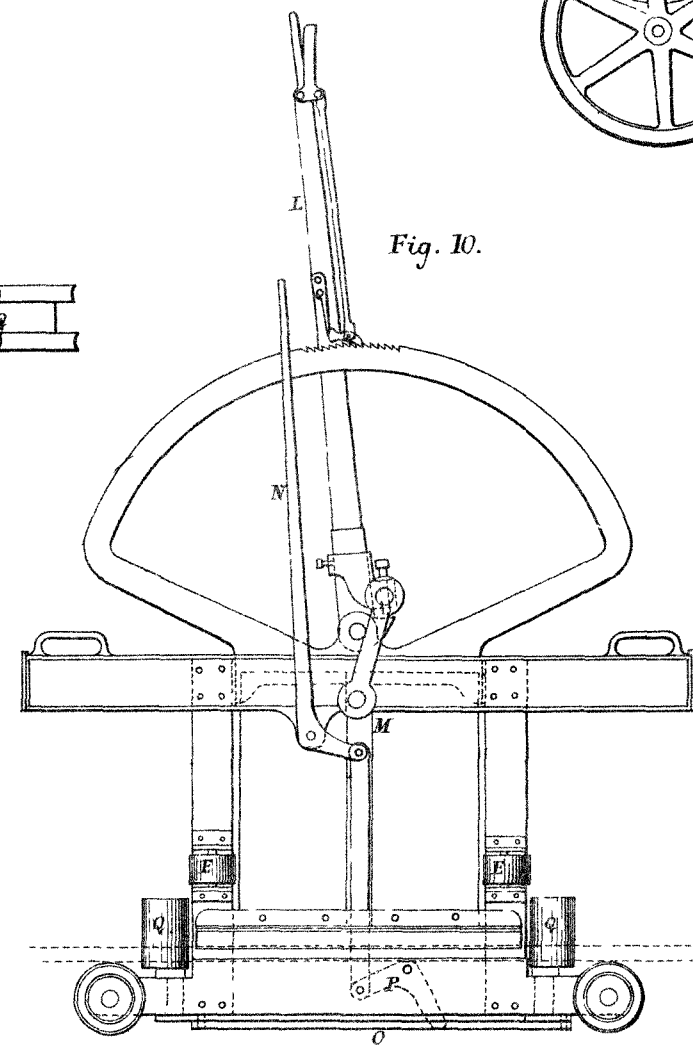


Fig. 7.

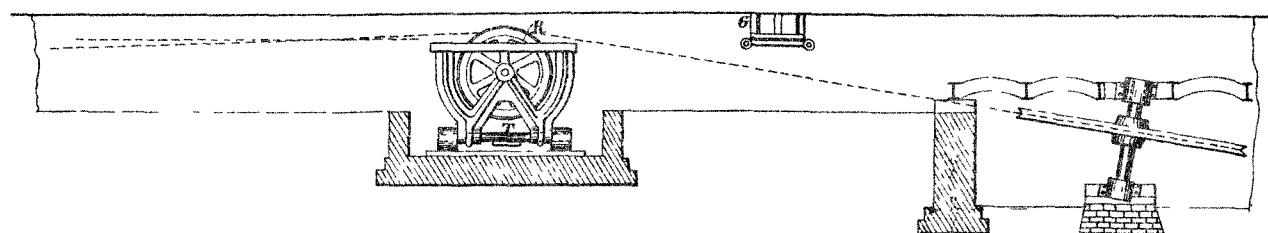


Fig. 8.

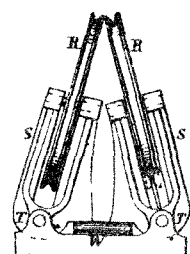


Fig. 9.



This is the Sheet of Drawings marked C referred to the annexed Letters of Registration granted to Charles Farquhar Findlay, this nineteenth day of May, 1883.  
Augustus Loftus.





A.D. 1883, 26th May. No. 1242.

IMPROVEMENTS IN SANITARY RECEPTACLES AND APPLIANCES.

LETTERS OF REGISTRATION to John Turner and James Robertshaw, for Improvements in Sanitary Receptacles and Appliances.

[Registered on the 26th day of May, 1883, in pursuance of the Act 16 Vic. No. 24.]

BY HIS EXCELLENCY THE RIGHT HONORABLE SIR AUGUSTUS WILLIAM FREDERICK SPENCER LOFTUS (commonly called LORD AUGUSTUS LOFTUS), Knight Grand Cross of the Most Honorable Order of the Bath, a Member of Her Majesty's Most Honorable Privy Council, Governor and Commander-in-Chief of the Colony of New South Wales and its Dependencies.

TO ALL TO WHOM THESE PRESENTS SHALL COME, greeting :

WHEREAS JOHN TURNER and JAMES ROBERTSHAW, of Manchester, in the County of Lancaster, England, have by their Petition humbly represented to me that they are the authors or designers of a certain invention or improvement in manufactures, that is to say, of an invention entitled "Improvements in Sanitary Receptacles and Appliances," which is more particularly described in the specification, marked A, and the three sheets of drawings, marked B, C, and D respectively, which are hereunto annexed; and that they, the said Petitioners, have deposited with the Honorable the Treasurer of the said Colony of New South Wales the sum of Twenty Pounds sterling, for defraying the expense of granting these Letters of Registration, as required by the Act of Council, sixteenth Victoria, number twenty-four, and have humbly prayed that I would be pleased to grant Letters of Registration, whereby the exclusive enjoyment and advantage of the said invention or improvement might be secured to them for a period of fourteen years: And I, being willing to give encouragement to all inventions and improvements in the arts or manufactures which may be for the public good, and having received a report favourable to the prayer of the said Petition, from competent persons appointed by me to examine and consider the matters stated therein and to report thereon for my information, am pleased, with the advice of the Executive Council, and in exercise of the power and authority given to me by the said Act of Council, to grant, and do by these Letters of Registration grant unto the said John Turner and James Robertshaw, their executors, administrators, and assigns, the exclusive enjoyment and advantage of the said invention or improvement, for and during the term of fourteen years from the date hereof; to have, hold, and exercise unto the said John Turner and James Robertshaw, their executors, administrators, and assigns, the exclusive enjoyment and advantage thereof, for and during and unto the full end and term of fourteen years from the date of these presents next and immediately ensuing, and fully to be complete and ended: Provided always, that if the said John Turner and James Robertshaw shall not, within three days after the granting of these Letters of Registration, register the same in the proper office in the Supreme Court, at Sydney, in the said Colony of New South Wales, then these Letters of Registration, and all advantages whatsoever hereby granted, shall cease and become void.

In witness whereof, I have hereunto set my sign manual, and have caused the present Letters of Registration to be sealed with the seal of the said Colony of New South Wales, at Government House, Sydney, in New South Wales, this twenty-sixth day of May, in the year of our Lord one thousand eight hundred and eighty-three.

[L.S.]

AUGUSTUS LOFTUS.

---

*Improvements in Sanitary Receptacles and Appliances.*


---

A.

TO ALL TO WHOM THESE PRESENTS SHALL COME: We, JOHN TURNER, of Manchester, in the County of Lancaster, and JAMES ROBERTSHAW, of the same place, in the Kingdom of Great Britain and Ireland, send greeting:

WHEREAS we are desirous of obtaining Letters of Registration for securing unto us Her Majesty's special license that we, our executors, administrators, and assigns, and such others as we or they shall at any time agree with, and no others, shall and lawfully may from time to time and at all times during the term of fourteen years, to be computed from the day on which this instrument shall be left at the office of the Minister for Justice, Sydney, make, use, exercise, and vend within the Colony of New South Wales an invention of improvements in sanitary receptacles and appliances, as more particularly described in the following specification and accompanying drawings forwarded herewith.

## SPECIFICATION.

OUR invention, styled the "Dividable Closet, or Improved Pail System," relates in the first place to improvements in sanitary pails or receptacles employed to contain and transport offensive matters, as is well understood, and has for its object to provide means to drain off any liquid thrown or shot into the said pails or receptacles, and allow it to filter, divide, and separate itself from the solid or partly solid matters contained therein. To this end we form, fit, and arrange within the pail or receptacle a perforated false bottom, or a corrugated bottom, or a perforated and corrugated bottom. Any liquid that may be thrown or placed in the pail or receptacle percolates or drains through the perforations, or runs down the corrugations in the false bottom into the pail or receptacle bottom, from whence it runs out through an opening or orifice formed therein. The said false bottom may be made of galvanized iron, tin, wood, or other suitable metal or material, and of a convex, concave, elliptical, conical, or other suitable form and construction. Two or more side straps or corrugations are formed or fitted within the pail, and are perforated in order that the liquid may drain through the same and run into the pail bottom. We place a small quantity of hay or other fibrous substance or material on the false bottom, which hay tends to keep the more solid matters from entering the perforations, and assists in the filtration to some extent. The liquid thus separated flows through the said opening formed in the pail bottom into the mouth of an elbow or other pipe laid thereunder, and connected with the drain. Within the mouth of the said pipe we place a charcoal block or a perforated box filled with charcoal, cinders, gravel, or other suitable filtering media, the object being to cleanse the liquid from solid impurities before allowing it to flow into the drain. The solid filtering media is fitted within the pipe loosely, so that it can be readily removed at any time for cleansing. A foundation site or bottom, made of earthenware, wood, or other suitable substance or material, is formed with abutments and orifices, the abutments being employed to ensure the proper position of the pail thereon, and the orifices allow of the connection being made from the pail bottom to the mouth of the elbow pipe connected with the drain. We may form around the said orifice a cylindrical part which fits into the elbow pipe and prevents the liquid coming into contact with the soil at this part, or we may pass through the said opening in the tile bottom a loose cylindrical pipe which conveys the urine or liquid flowing from the pail or guard into the drain. The invention relates in the next place to improvements in the form and construction of guard placed under the closet seat, and consists in forming a recess or bulge at its central part, in order that the guard may be fixed well under the seat, and at the same time not be in the way when used. At the front part and lower end of the said guard we form or fit a plate or partition so that any urine which may resist being carried away by the guard is deflected into the pail and prevents it falling on to the floor of the closet. Any ordinary and suitable arrangement may be employed for ventilating the closets. By these means we are enabled to separate and drain away the liquids from the solids immediately they are thrown or shot into the pail, which pails do not require so frequent emptying as at present, and the generation of noxious odours is prevented, also the cost of collection of such matters is considerably reduced.

And in order that the invention may be better understood, we have caused to be appended hereto three sheets of drawings, in which figure 1 represents a pail or receptacle provided with our perforated false bottom *b*, formed with channels *b'*, and with an outlet for the liquid. In this example the said false bottom *b* is of a convex form, but any suitable shape can be employed. The rim of the said false bottom *b* rests upon the bottom of the pail, which, in the example, is slightly concave, a cavity or space being formed between the two bottoms. The perforated side straps *d* are intended to assist in the filtration, by taking away the liquid more readily than cannot get easily through the solid matters in the pail, but the recesses or corrugations *c*, built up at the front with a perforated plate, may be employed either with or without the said side straps *d*, which said straps rest loosely on the false bottom, and can be quickly removed when the pail is to be emptied of its contents. Figures 2 and 3 represent a side view and plan of figure 1. Figures 4 and 5 represent a front view and plan of the said tile bottom *f*, formed in this case with circular abutments, *g*, *f*, which abutments ensure the correct position of the pail thereon, and which bring the opening or outlet *e* immediately over the opening *j* and pipe *h*. The channel *i*, which receives urine from the guard by means of any ordinary arrangement of piping, is formed with the tile *f*. Figures 5, 7, and 8 represent different forms of abutments. Figure 12 represents the pipe *h*, which is laid underneath the tile bottom, and is connected with the drain. A metal perforated box, *n*, filled with filtering media, as, for example, charcoal, gravel, or cinders, is fitted loosely within the pipe *h*, and can be readily removed at any time for cleansing, or we may employ a charcoal block, *n'*, alone, and fit it within the neck of the pipe *h*, as indicated by figure 13, the object being to cleanse the liquid of solid impurities before removing it into the drain. Figures 9, 10, and 11 represent views of our improved guard. It will be seen that the bulge or recess *k* forms a clearance on the guard at the part which is now in the way when in use. The plate or partition *l*, formed on the lower part and bottom of the guard, prevents any liquid that may miss the guard from falling on to the floor, the plate or partition acting to deflect it into pail; so also when the bib of the guard should by accident become stopped up, the urine or liquid would flow over the tip of the guard and over the said plate or partition *l* into the pail, which is an important feature in this part of our invention. Figure 14 represents the tile bottom *f*, formed with a branch, *m*, to fit the socket of the pipe *h*. Figure 15 is a plan of the tile bottom with straight abutments. Having

*Improvements in Sanitary Receptacles and Appliances.*

Having now described and illustrated the nature and particulars of our invention, and the manner in which the same is to be performed, we desire it to be understood that we claim, without binding ourselves to the precise arrangement and the construction of the parts described—

First.—The combination with a sanitary pail or receptacle of a perforated false bottom, for the purpose of allowing any contained liquid therein to percolate and fall into the pail bottom, substantially as herein before described and as illustrated in the accompanying drawings.

Secondly.—Forming the pail bottom with an orifice or outlet for the liquid, substantially as described and shown.

Thirdly.—The improved form and construction of guard, acting substantially as described and as illustrated in the drawings.

Fourthly.—The employment and form of foundation tile or bottom, as and for the purpose hereinbefore mentioned.

Fifthly.—The form and arrangement of piping for conveying the liquid from the pail and guard into the drain, substantially as described.

Sixthly.—The employment of filtering media in the receiving pipe *h*, for the purpose set forth.

HENRY HALLOMAN, Patent Agent.  
2, Wentworth Court, Sydney, 13th March, 1883.

JOHN TURNER.  
JAMES ROBERTSHAW,  
*per* EDWIN WILLIAMS.

This is the specification, marked A, referred to in the annexed Letters of Registration granted to John Turner and James Robertshaw, this twenty-sixth day of May, A.D. 1883.

AUGUSTUS LOFTUS.

---

REPORT.

---

Sir,

The application of Messrs. John Turner and James Robertshaw for Letters of Registration for "Improvements in Sanitary Receptacles and Appliances" having been referred to us, we have examined the specification and drawings accompanying the same, and have the honor to report that we see no objection to the issue of Letters of Registration as prayed for.

Sydney, 28 March, 1883.

The Under Secretary of Justice.

We have, &c.,  
CHAS. WATT.  
EDMUND FOSBERY.

---

[Drawings—three sheets.]

FIG. 1.

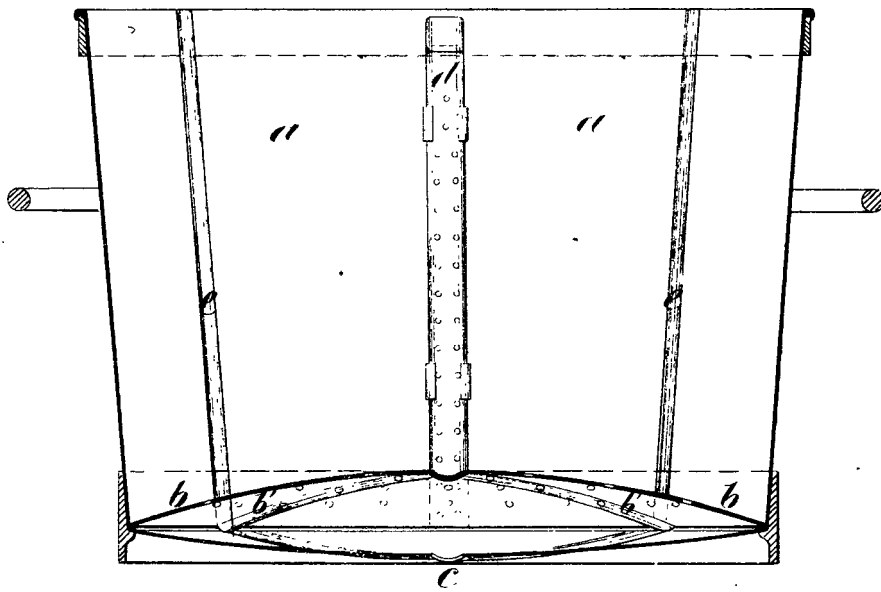


FIG. 2.

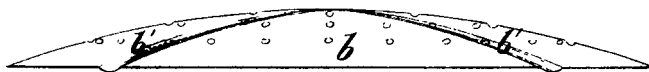
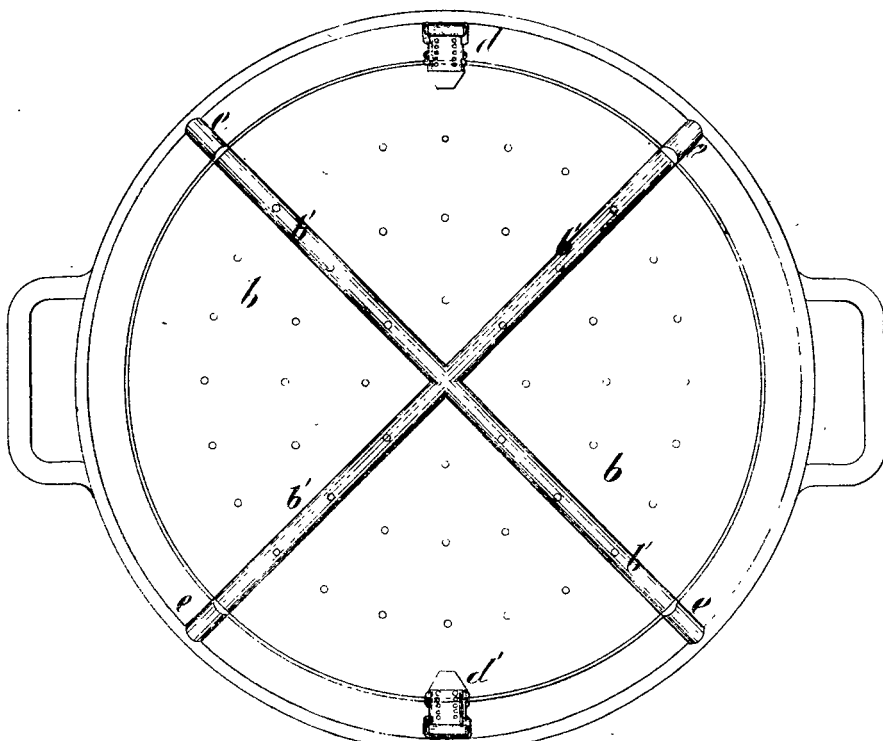
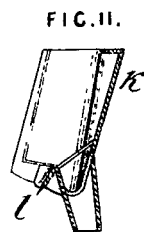
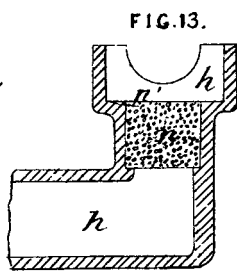
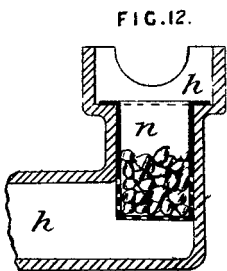
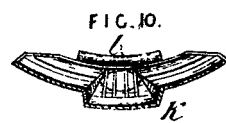
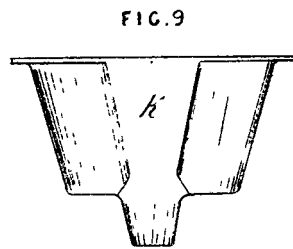
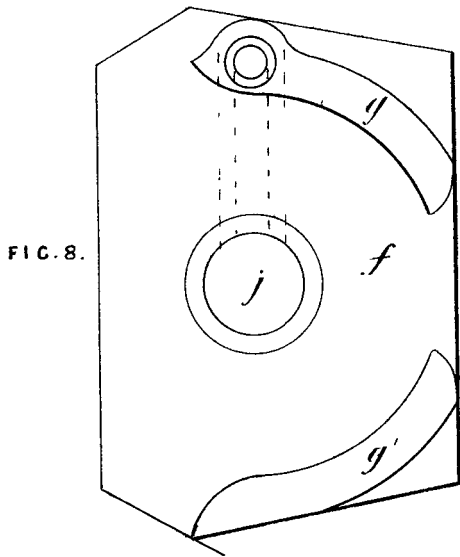
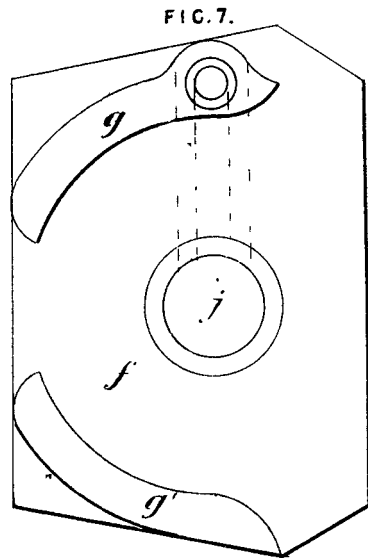
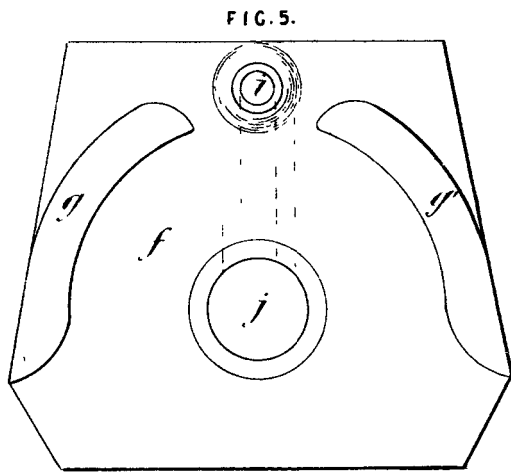
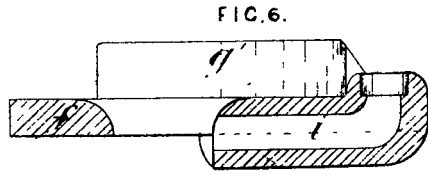
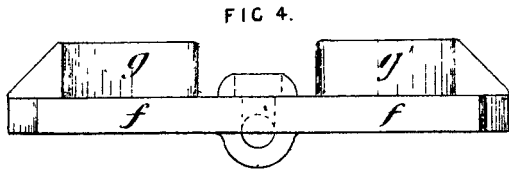


FIG. 3.



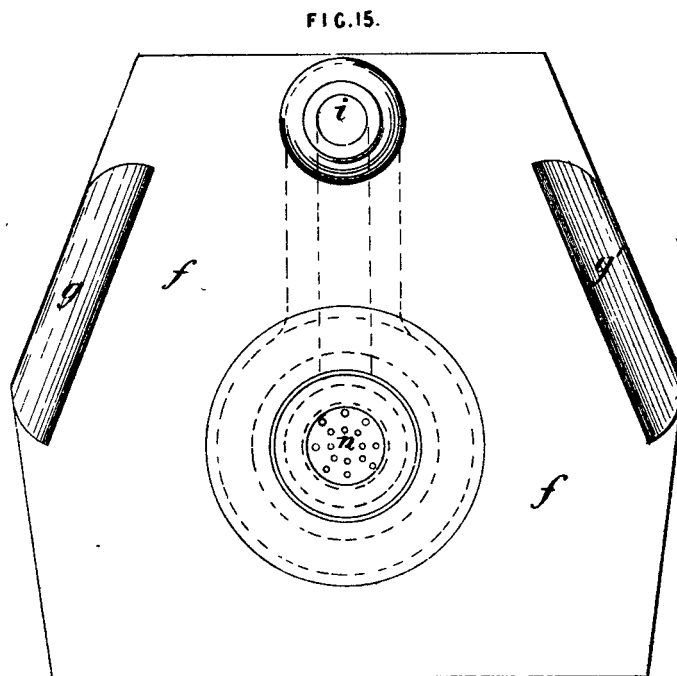
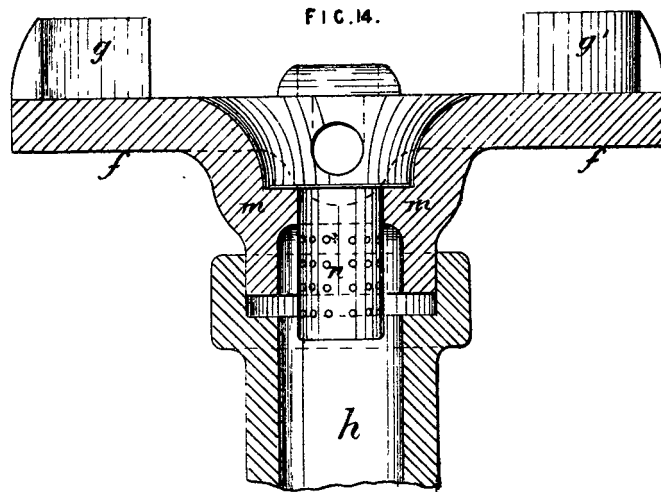
*This is the Sheet of Drawings marked B preferred to in the annexed Letters of Registration granted to John Turner and James Robertshaw, this 26<sup>th</sup> day of May, 1883. Augustus Loftus.*



*This is the Sheet of Drawings marked C referred to in the annexed Letters of Registration granted to John Turner and James Robertshaw. this 26<sup>th</sup> day of May, 1883.*

*Augustus Loftus.*

D.



*This is the Sheet of Drawings marked D. referred to in the annexed Letters of Registration granted to John Turner, and James Robert Shaw, this twenty sixth day of May, A. D. 1883.*

*Augustus Loftus.*



A.D. 1883, 26th May. No. 1243.

THE HYDRA-HEADED RAIL.

LETTERS OF REGISTRATION to George Cowdery and Edwin Robins Thomas, for an improved Rail for Railways, to be called "The Hydra-headed Rail."

[Registered on the 26th day of May, 1883, in pursuance of the Act 16 Vic. No. 24.]

BY HIS EXCELLENCY THE RIGHT HONORABLE SIR AUGUSTUS WILLIAM FREDERICK SPENCER LOFTUS (commonly called LORD AUGUSTUS LOFTUS), Knight Grand Cross of the Most Honorable Order of the Bath, a Member of Her Majesty's Most Honorable Privy Council, Governor and Commander-in-Chief of the Colony of New South Wales and its Dependencies.

TO ALL TO WHOM THESE PRESENTS SHALL COME, greeting :

WHEREAS GEORGE COWDERY and EDWIN ROBINS THOMAS, both of Sydney, in the Colony of New South Wales, hath by their Petition humbly represented to me that they are the authors or designers of a certain invention or improvement in manufactures, that is to say, of an invention of "An improved Rail for Railways, to be called The 'Hydra-headed Rail,'" which is more particularly described in the specification and the sheet of drawings which are hereunto annexed; and that they, the said Petitioners, have deposited with the Honorable the Treasurer of the said Colony of New South Wales the sum of Twenty Pounds sterling, for defraying the expense of granting these Letters of Registration, as required by the Act of Council, sixteenth Victoria, number twenty-four; and have humbly prayed that I would be pleased to grant Letters of Registration, whereby the exclusive enjoyment and advantage of the said invention or improvement might be secured to them for a period of fourteen years: And I, being willing to give encouragement to all inventions and improvements in the arts or manufactures which may be for the public good, and having received a report favourable to the prayer of the said Petition from competent persons appointed by me to examine and consider the matters stated therein and to report thereon for my information, am pleased, with the advice of the Executive Council, and in exercise of the power and authority given to me by the said Act of Council, to grant, and do by these Letters of Registration grant unto the said George Cowdery and Edwin Robins Thomas, their executors, administrators, and assigns, the exclusive enjoyment and advantage of the said invention or improvement, for and during the term of fourteen years from the date hereof; to have, hold, and exercise unto the said George Cowdery and Edwin Robins Thomas, their executors, administrators, and assigns, the exclusive enjoyment and advantage thereof, for and during and unto the full end and term of fourteen years from the date of these presents next and immediately ensuing, and fully to be complete and ended: Provided always, that if the said George Cowdery and Edwin Robins Thomas shall not, within three days after the granting of these Letters of Registration, register the same in the proper office in the Supreme Court, at Sydney, in the said Colony of New South Wales, then these Letters of Registration, and all advantages whatsoever hereby granted, shall cease and become void.

In witness whereof, I have hereunto set my sign manual, and have caused the present Letters of Registration to be sealed with the seal of the said Colony of New South Wales, at Government House, Sydney, in New South Wales, this twenty-sixth day of May, in the year of our Lord one thousand eight hundred and eight-three.

[L.S.]

AUGUSTUS LOFTUS.

*The Hydra-headed Rail.*

TO ALL TO WHOM THESE PRESENTS SHALL COME: We, GEORGE COWDERY and EDWIN ROBINS THOMAS, both of Sydney, in the Colony of New South Wales, send greeting:

WHEREAS we are desirous of obtaining Letters of Registration for securing unto us Her Majesty's special license that we, our executors, administrators, and assigns, and such others as we or they shall at any time agree with, and no other, shall and lawfully may from time to time and at all times during the term of fourteen years, to be computed from the day on which this instrument shall be left at the office of the Minister for Justice, Sydney, make, use, exercise, and vend within the Colony of New South Wales an invention of an improved rail for railways, to be called "The Hydra-headed Rail," invented and constructed by us, as more particularly described in the following specification and accompanying drawings.

## SPECIFICATION.

THE rail complete consists in the combination of two separate sections or rails, of the same transverse section as shown in the drawings (transverse section at A A). The two sections or rails are to be placed or built together to form one rail.

The two rails or sections, which combined form the rail, having the same transverse section can be turned over laterally or end for end, and either be made to take the place or position of the other, thus giving in such change of position a fresh working surface or tread. This combination has the advantage of a four-headed rail.

The rails are to be seated at intervals in chairs placed upon sleepers, and the chairs pinned to the sleepers in the ordinary manner.

The chairs are to be of the form shown, or of a form similar to that shown in the drawing, according to the sizes and weights of the rails to be used.

At given spaces the two sections of the rail are to be fixed together by pins or bolts (see drawing of pins at B). These pins or bolts pass through elongated holes in each section of the rails, as shown in accompanying drawing E E.

While placing these pins or bolts in position the rails or sections must be sprung towards each other by means of a cramp for this purpose. When the pins or bolts are in position, and the cramp released, the shoulder under the head of the pin fits into the elongated hole tightly, preventing any possibility of the pin turning or altering its position, thus forming a perfect tie or fastening.

The pins or bolts cannot be displaced except by the use of the cramp, and the tendency of the load upon the rails is to tighten the pins.

By this combination a break of joint can be secured (see drawing at E) without the use of the fish-plates, screw bolts, and nuts, and without reducing the strength or efficiency of the rail in any respect.

With this combination rail the use of keys in the chairs is entirely superseded as the lower flanges of the section of rail fix tightly under the lips of the chairs, thus preventing any possibility of wear in the faces of the flanges previous to their being turned. However, in some instances, it may be deemed advisable to use a pin or bolt of the form shown at the chairs, for which provision has been made (see drawing of chairs).

The rolling weight or load is sustained entirely by a centre piece in the chair, on which the upper flanges rest (see drawing at G).

## ADVANTAGES.

The advantages of the above specified rail are—

It combines all the best qualities of the Barlow rail, the double-headed rail, the Bridge rail, and rail of the contractors' pattern.

The distribution of metal in each section will allow of their being well and soundly rolled. Less weight per lineal yard to sustain an equal load.

Four new and independent flanges to work over, giving a longer life to the rail than any at present in use.

Fish-plates, screw-bolts, and nuts are not required for fixing. Perfection in break of joint without weakness—wooden keys dispensed with. Few fastenings requisite.

Rapidity of laying, relaying, or shifting.

Considerably less weight in rails per lineal yard for equal loads than any rails in use.

The lower section could be used as a permanent foundation (and if considered more economical) of tougher metal, and the upper section of steel, which alone need be shifted or renewed.

Points, crossings, and switches similar to those at present in use would remain undisturbed.

## CLAIMS.

And having now described our invention, and enumerated its advantages, we claim specifically the right and use of the novelty of building up and constructing rails for railways of sections of the form shown, or of similar forms to those shown, in the accompanying drawings, to produce a perfectly stable and efficient road or track for the wheels of rolling stock to run upon, and with four perfect and independent flanges to work upon, giving a longer life to the track, combined with the greatest economy of metal for the required strength, while the weight in the fastenings will be at least 40 per cent. less than for any other rail at present in use.

HENRY HALLORAN, Patent Agent,  
2, Wentworth Court, Sydney, 10 March, 1883.

GEORGE COWDERY.  
EDWIN ROBINS THOMAS.

This is the specification referred to in the annexed Letters of Registration granted to George Cowdery and Edwin Robins Thomas, this twenty-sixth day of May, A.D. 1883.

AUGUSTUS LOFTUS.

REPORT.



---

*The Hydra-headed Rail.*

---

REPORT.

---

Sir, Sydney, 2 April, 1883.  
We do ourselves the honor to report, in reply to your B.C. communication of the 17th ultimo, No. 83-3,452, that we are of opinion that the prayer of Messrs. Cowdery and Thomas for the Registration of an invention entitled "An improved Rail for Railways, to be called the Hydra-headed Rail," may be granted, in terms of their specification, drawing, and claim.

The Under Secretary of Justice.

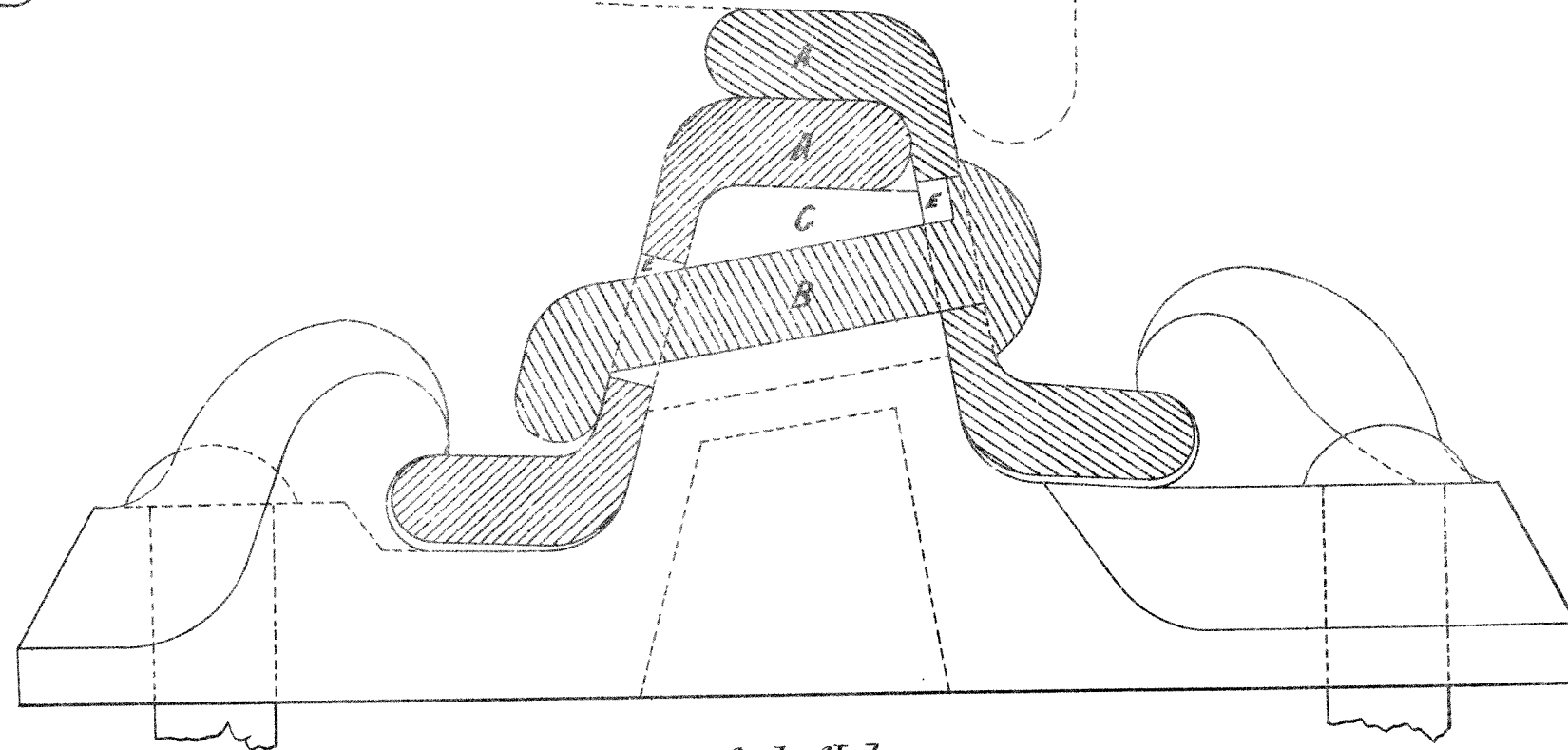
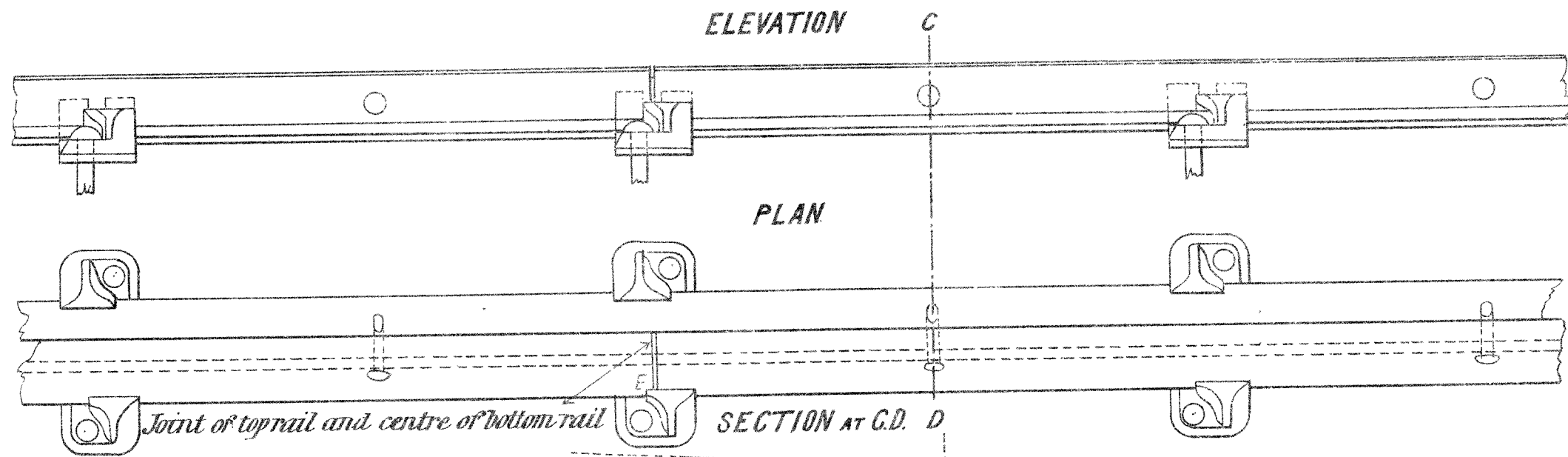
We have, &c.,  
JOHN WHITTON.  
E. O. MORIARTY.

---

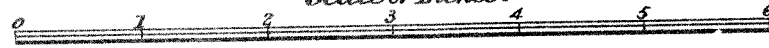
[Drawings—one sheet.]

# THE HYDRA-HEADED RAIL.

Scale of Feet.



Scale of Inches.



*This is the Sheet of Drawings referred to in the annexed  
 Letters of Registration granted to George Cowdery and Edward  
 Robins Thomas this twenty sixth day of May A.D. 1883.*

*Augustus Loftus.*



A.D. 1883, 26th May. No. 1244.

**AN IMPROVED METHOD OF STOWING BAGS OF WOOL, &c., IN BOARD VESSELS,  
AND THEREBY FORMING PRESERVING COMPARTMENTS.**

LETTERS OF REGISTRATION to Herbert Maguire Whitehead, for an improved method of and appliances for stowing bags of wool, hair, jute, and the like, in board steam and other vessels, and the formation of walls of chambers or compartments thereby within which meat and other perishable food may be preserved.

[Registered on the 29th day of May, 1883, in pursuance of the Act 16 Vic. No. 24.]

BY HIS EXCELLENCY the RIGHT HONORABLE SIR AUGUSTUS WILLIAM FREDERICK SPENCER LOFTUS (commonly called LORD AUGUSTUS LOFTUS), Knight Grand Cross of the Most Honorable Order of the Bath, a Member of Her Majesty's Most Honorable Privy Council, Governor and Commander-in-Chief of the Colony of New South Wales and its Dependencies.

TO ALL TO WHOM THESE PRESENTS SHALL COME, greeting :

WHEREAS HERBERT MAGUIRE WHITEHEAD, of 7, Lothbury, of the City of London, in England, hath by his Petition humbly represented to me that he is the author or designer of a certain invention or improvement in manufactures, that is to say, of an invention entitled "An improved method of and appliances for stowing bags of wool, hair, jute, and the like, in board steam and other vessels, and the formation of walls of chambers or compartments thereby within which meat and other perishable food may be preserved," which is more particularly described in the specification, marked "A," and the two drawings, marked "B" and "C" respectively, which are hereunto annexed ; and that he, the said Petitioner, hath deposited with the Honorable the Treasurer of the said Colony of New South Wales the sum of Twenty Pounds sterling, for defraying the expense of granting these Letters of Registration, as required by the Act of Council, sixteenth Victoria, number twenty-four ; and hath humbly prayed that I would be pleased to grant Letters of Registration, whereby the exclusive enjoyment and advantage of the said invention or improvement might be secured to him for a period of fourteen years : And I, being willing to give encouragement to all inventions and improvements in the arts or manufactures which may be for the public good, and having received a report favourable to the prayer of the said Petition from competent persons appointed by me to examine and consider the matters stated therein and to report thereon for my information, am pleased, with the advice of the Executive Council, and in exercise of the power and authority given to me by the said Act of Council, to grant, and do by these Letters of Registration grant unto the said Herbert Maguire Whitehead, his executors, administrators, and assigns, the exclusive enjoyment and advantage of the said invention or improvement, for and during the term of fourteen years from the date hereof ; to have, hold, and exercise unto the said Herbert Maguire Whitehead, his executors, administrators, and assigns, the exclusive enjoyment and advantage thereof, for and during and unto the full end and term of fourteen years from the date of these presents next and immediately ensuing, and fully to be complete and ended : Provided always, that if the said Herbert Maguire Whitehead shall not, within three days after the granting of these Letters of Registration, register the same in the proper office in the Supreme Court, at Sydney, in the said Colony of New South Wales, then these Letters of Registration, and all advantages whatsoever hereby granted, shall cease and become void.

In witness whereof, I have hereunto set my sign manual, and have caused the present letters of Registration to be sealed with the seal of the said Colony of New South Wales, at Government House, Sydney, in New South Wales, this twenty-sixth day of May, in the year of our Lord one thousand eight hundred and eighty-three.

[L.S.]

AUGUSTUS LOFTUS.

*An improved method of stowing bags of wool, &c., in board*

A.

SPECIFICATION of HERBERT MAGUIRE WHITEHEAD'S invention for "An improved method of and appliances for stowing bags of wool, hair, jute, and the like, in board steam and other vessels, and the formation of walls of chambers or compartments thereby within which meat and other perishable food may be preserved."

THE object of this invention is to form, open, or skeleton partitions of timbers or battens, bars, and screws, for compressing bales or bags of wool, hair, jute, and the like, to serve as walls, partitions, or temporary bulkheads to chambers in which meat and other perishable food may be kept in board steamships and vessels used for the transport thereof, the timbers, bars, and screws being movable for releasing the bags of wool, hair, jute, or the like when desired, and capable of being refixed in position when and where necessary.

By this invention food-preservation chambers are kept cool, the material being non-conductors of heat and moisture.

The materials are imported in large quantities, and when compressed in the manner and for the purposes mentioned above a great saving of space and freightage is effected, and dispenses with permanent non-conducting walls, partitions, and bulkheads.

For the purposes of my invention I bolt or suspend to the ceiling frames of a vessel, 'tween decks, a series of uprights provided with threaded rods which can be turned by levers. To the inside of the uprights I fit horizontal, or they may be vertical, timbers or battens or bars, against which the inner ends of the threaded rods bear. If the inner timbers or bars are vertical I fit other timbers or bars horizontally inside of them to bear against the bags of wool, hair, jute, flax, or other material contained in such bags.

These bags, which I prefer should be of about mattress size, and to be arranged on edge, so that one side bears against the side the deck posts or other parts of the vessel's framing, the bags being piled so as to fill, or nearly fill, the space between floor and ceiling. I then turn the screws to force the internal horizontal or vertical timber or bars against the flat portions of the bags to compress the contents, said compressions forcing the ends of the bags outwards, the sides next the skin of the vessel into close contact therewith, or into close contact with other timbers, bars, and screws, to form an independent screen or partition between any part of the vessel, so that the space between such screens may serve as the chamber in which meat or other food may be kept or preserved.

My screws of compressed wool, hair, flax, jute, or other material may also form the flooring and the ceiling or roofing to the chambers, as well as the sides and ends, and any one or more of them may be removed, if desired, without disturbing the others. Thus any part of the vessel's hull can be examined for repairs or otherwise, or any chamber can be examined for repairs or otherwise, or any chamber can be opened by simply removing the bags from one screen.

By my invention I obviate the necessity of fitting up permanent walls or partitions in holds or 'tween decks of vessels as is now done; I also facilitate the transport of the raw material without injury; and I utilise said raw materials as screens or partitions as non-conducting walls to the chambers in which the meat is preserved, instead of necessitating such raw material being transported as distinct cargoes.

The annexed drawings clearly show how I purpose carrying my invention into practice, although I do not limit myself to the exact details shown or described.

Figure 1 is a part sectional view of a vessel, and figure 2 a part sectional elevation, in the upper portion of which the wool, hair, jute, or other fibre is shown loosely in position, and at the lower portion in a practically and a wholly compressed state. The wool, hair, jute, or other fibre is arranged in bags of preferably mattress size, say 6 feet by 3 feet, for easy handling and stowage. These are arranged on the long or short ends for the walls or vertical partitions or bulkheads, and on the flat for floors or ceilings, and in single or double layers, as desired.

A A are hooks, whose shanks B B are single, as at figure 3, or double, as at figure 4, to enable them to be bolted either by through bolts or by pinch bolts to the ceiling frame C or other part of a vessel for the easy attachment, by suspension or otherwise, of horizontal rods or bars, D D, forming abutments for the upper ends of vertical bars, E E, of wood or metal, which carry screws F F, capable of being turned by hand, lever, or wheel, G G, to press against other bars, H H, for compressing the bags I I to the desired extent. The bars H H may be of sufficient width to serve as battens for acting direct upon or against the bags, or they may be as bars only, as at figure 2, to bear against battens, J J, arranged between them and the bags. The battens are preferably timber planks, roughly cut, so that no preparation is needed for them; other planks, K K, as battens, may, if desired, be fitted.

The lower part of the bars E E can be stepped into the floor L or into sockets fitted thereon, or they may be bolted firmly to it as at M.

In this drawing I have shown the application or employment of my invention to the inside of the vessel's skin, but it will be readily understood that intermediate temporary screens or bulkheads can be fitted by simply affixing two sets of screw-bars in the opposite direction to each other at any part of the vessel.

The screw-bars E E may be so arranged that they can be used for compression purposes only, and the battens or planks be then bolted or fixed in position, as at the side shown in the lower part of figure 1, by angle iron bolted to the floor and ceiling frame at intervals; the screw-bars E E can then be removed and used in a similar manner for other walls, screens, or partitions, in the same vessel.

The lower part of figure 1 also shows how I purpose arranging bags of wool, jute, hair, or other fibre, against the ceiling of a vessel, and between the ceiling frames. In this the bags are first arranged on battens supported by quartering N N, and rods by the hooks; pressure is then applied from underneath in any suitable manner somewhat beyond that which is intended to enable bars to be slipped into the hooks and under the battens or quartering to support them; the pressure is then released and the appliances removed, leaving the bags, &c., as shown under the middle deck in figure 1.

Figure

*vessels, and thereby forming preserving compartments.*

Figure 5 represents a half sheer plan of a vessel in which the upright bars P P are hinged or pivoted to the ceiling framing Q by sockets R (see also figure 6), so as to swing from them or to foot sockets bolted to the deck, as at S S, so that they can be folded down upon the floor and the battens and bags arranged upon them. They can then be turned up and a pressure exerted against the top to compress the bags until the uprights touch the upper sockets to enable them to be bolted thereto, and be thereby held in position.

If the uprights P P are suspended and their lower ends left loose I fit ribs T T to project from the inner portion of the ship's side V, to retain the bags temporarily in position until the requisite number be inserted between the skin V<sup>1</sup> and the uprights P P; I then, by lever, screw, or other pressure, force the lower ends of the uprights in and bolt them to the sockets or steps as at S.

In some cases I cast or otherwise form the upper sockets with a wing, W, to enable horizontal bars, Y, to be fitted, preferably by a bolt, on to them, the opposite end being similarly fitted, or with a clamp for attachment to a deck post, X, or to an appliance fitted to receive it.

The mode of compressing may be the same as that last described, or as desired.

I have hitherto referred to walls, screens, partitions, bulkheads, and ceilings for my system of compressed wool, hair, jute, or fibre, in bags, for meat or provision-preservation chambers, but the floors may be also formed by them, so as to isolate the chambers from the atmosphere and other contaminating or destructive surroundings; and said chambers may contain any antiseptic, deodorizing, or preserving agent, as desired.

Figures 7 to 12 show details of sockets, &c., which I propose to use with the last-described arrangement.

From the foregoing description and an examination of the drawings it will be evident to practical men that various modifications of appliances may be adapted for the purpose of carrying my invention, viz., that of utilizing bags of wool, hair, jute, and other fibres, as walls, partitions, screens, or bulkheads in vessels, into effect.

Having thus described the nature of my said invention, and in what manner the same is to be performed, I do not claim the compression of bags containing wool, hair, jute, or other fibre in board ships or vessels in a broad sense, because such may be effected by simply placing a series of bags one upon another, and by then forcing the top one in place, which, being done at intervals, could form chambers; but what I do claim as novel and useful is,—

The improved system or method of forming or building up temporary partitions in board ships or vessels by the utilization of bags containing wool, hair, jute, or fibre, as hereinbefore described, and substantially as shown in the annexed drawings.

H. M. WHITEHEAD.

This is the specification, marked A, referred to in the annexed Letters of Registration granted to Herbert Maguire Whitehead, this twenty-sixth day of May, A.D. 1883.

AUGUSTUS LOFTUS.

## REPORT.

Sir,

Sydney, 30 March, 1883.

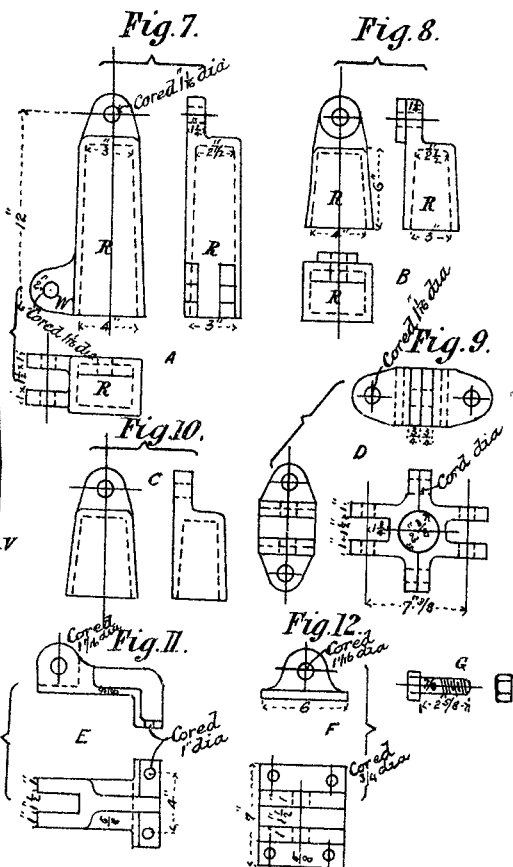
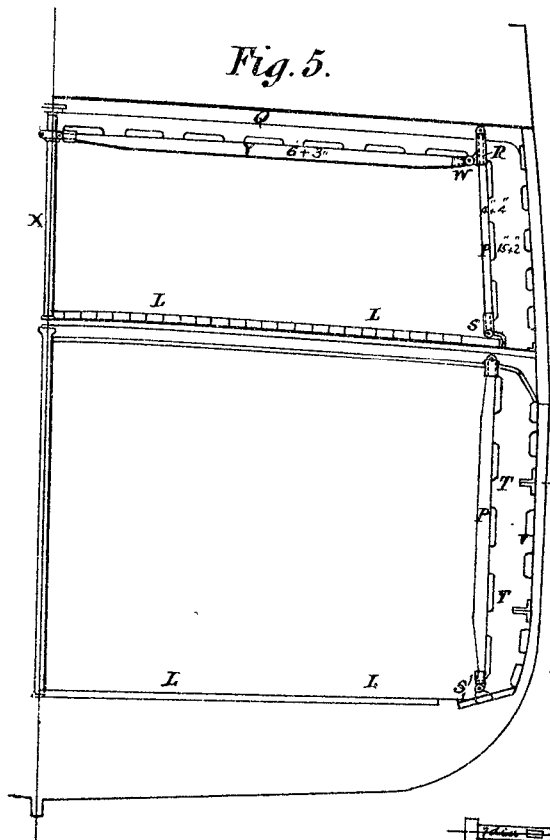
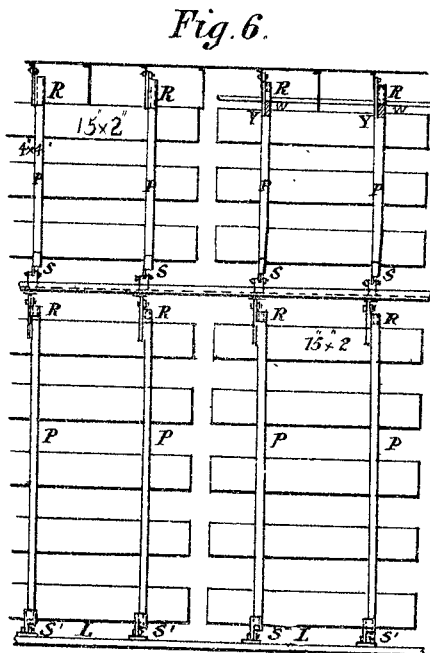
We do ourselves the honor to report, in reply to your blank cover of the 17th instant, No. 3,709, transmitting the petition of Herbert Maguire Whitehead for the registration of an invention entitled "An improved method of and appliances for stowing bags of wool, hair, jute, and the like in board steam and other vessels, and the formation of walls of chambers or compartments thereby, within which meat and other perishable food may be preserved," that we are of opinion the prayer of Mr. Whitehead's Petition may be granted in terms of his specification, drawings, and claim.

We have, &c.,

FRANCIS HIXSON:  
GOTHER K. MANN.

The Under Secretary of Justice.





This is the Sheet of Drawings marked C. referred to in the annexed Letters of Registration granted to Herbert Maguire Whitehead, this twenty sixth day of May, A.D. 1883.

Augustus Loftus.

This is the drawing referred to in the annexed Specification.

H. M. Whitehead.

(Sig. 35-)



A.D. 1883, 26th May. No. 1245.

**IMPROVEMENTS IN THE METHOD OR PROCESS FOR EXTRACTING, REFINING,  
AND HARDENING PARAFFINE WAX**

LETTERS OF REGISTRATION to Heinrich Ujhely, for Improvements in the method or process for extracting, refining, and hardening Paraffine Wax.

[Registered on the 29th day of May, 1883, in pursuance of the Act 16 Vic. No. 24.]

BY HIS EXCELLENCY THE RIGHT HONORABLE SIR AUGUSTUS WILLIAM FREDERICK SPENCER LOFTUS (commonly called LORD AUGUSTUS LOFTUS), Knight Grand Cross of the Most Honorable Order of the Bath, a Member of Her Majesty's Most Honorable Privy Council, Governor and Commander-in-Chief of the Colony of New South Wales and its Dependencies.

TO ALL TO WHOM THESE PRESENTS SHALL COME, greeting :

WHEREAS HEINRICH UJHELY, of Vienna, in the Empire of Austria, hath by his Petition humbly represented to me that he is the author or designer of a certain invention or improvement in manufactures, that is to say, of an invention entitled "Improvements in the method or process for extracting, refining, and hardening paraffine wax," which is more particularly described in the specification which is hereunto annexed ; and that he, the said Petitioner, hath deposited with the Honorable the Treasurer of the said Colony of New South Wales the sum of Twenty Pounds sterling, for defraying the expense of granting these Letters of Registration, as required by the Act of Council, sixteenth Victoria, number twenty-four ; and hath humbly prayed that I would be pleased to grant Letters of Registration, whereby the exclusive enjoyment and advantage of the said invention or improvement might be secured to him for a period of fourteen years : And I, being willing to give encouragement to all inventions and improvements in the arts or manufactures which may be for the public good, and having received a report favourable to the prayer of the said Petition, from competent persons appointed by me to examine and consider the matters stated therein and to report thereon for my information, am pleased, with the advice of the Executive Council, and in exercise of the power and authority given to me by the said Act of Council, to grant, and do by these Letters of Registration grant unto the said Heinrich Ujhely, his executors, administrators, and assigns, the exclusive enjoyment and advantage of the said invention or improvement, for and during the term of fourteen years from the date hereof ; to have, hold, and exercise unto the said Heinrich Ujhely, his executors, administrators, and assigns, the exclusive enjoyment and advantage thereof, for and during and unto the full end and term of fourteen years from the date of these presents next and immediately ensuing, and fully to be complete and ended : Provided always, that if the said Heinrich Ujhely shall not, within three days after the granting of these Letters of Registration, register the same in the proper office in the Supreme Court, at Sydney, in the said Colony of New South Wales, then these Letters of Registration, and all advantages whatsoever hereby granted, shall cease and become void.

In witness whereof, I have hereunto set my sign manual, and have caused the present Letters of Registration to be sealed with the seal of the said Colony of New South Wales, at Government House, Sydney, in New South Wales, this twenty-sixth day of May, in the year of our Lord one thousand eight hundred and eighty-three.

[L.S.]

AUGUSTUS LOFTUS.



*Improvements in the method for extracting, refining, and hardening paraffine wax.*

SPECIFICATION of HEINRICH UJHELY, of Vienna, in the Empire of Austria, for an invention entitled "Improvements in the method or process for extracting, refining, and hardening paraffine wax."

IN a suitable enclosed vessel, the precise construction of which is not material to the carrying out of this invention, is placed the crude paraffine or scales, together with the solvents. The solvents consist of a mixture of, *a*, petroleum, ether (benzine, gasoline, or naphtha), and *b*, alcohol (this may be either pure, ethyl, methyl, or amyl alcohol, or a mixture of two or all of these different kinds of alcohol).

The proportional quantity of the solvents *a* and *b* is variable, depending upon the quality of the crude material to be worked up, and must be regulated in each case according to the requirements of that particular case. This will be well understood by chemists and others skilled in this subject.

To insure the complete dissolving of the crude material, heat may be applied to the vessel so as to raise the temperature at any rate above the melting point of the crude material, after which it is allowed to cool down.

As this solution cools the paraffine crystallizes, thus separating itself from the oils contained in the crude material, which remain in a dissolved state in the solvents.

The paraffine thus recovered by crystallization is as much as possible freed from the solvents which it still contains, by passing it through a filter press or hydraulic press, and the last traces of the solvents are removed by evaporation, the solvents being recovered, if desired, by condensation.

The heavy mineral oils which formed part of the raw material are contained in a dissolved state in the solvents (which have been separated from the paraffine by crystallization and the presses, as already described), and in order to separate these oils from the solvents, the solution is distilled in the well-known manner, which is all the easier, as the boiling point of the solvents is considerably lower than that of the mineral oils.

The paraffine is bleached by being melted and digested with the powder which is a residue from the manufacture of the ferrocyanide of potassium, and finally the paraffine is filtered through filtering paper.

Having now described the nature of my invention, and in what manner the same is to be performed, I claim—

First—The dissolving of the crude paraffine or scales in the solvents, substantially as set forth, for the purpose of separating the pure paraffine from the heavy mineral oils contained in the crude material.

Second—In combination with the herein described process for separating the pure paraffine from the heavy mineral oils, the bleaching of the thus obtained paraffine by means of the residual product from the manufacture of ferrocyanide of potassium, substantially as set forth.

In witness whereof, I, the said Heinrich Ujhely, have hereunto set my hand and seal, this eighth day of January, in the year of our Lord one thousand eight hundred and eighty-three.

HEINRICH UJHELY.

Witness—JOHANNES BISCH.

This is the specification referred to in the annexed Letters of Registration granted to Heinrich Ujhely, this twenty-sixth day of May, A.D. 1883.

AUGUSTUS LOFTUS.

## REPORTS.

Sir,

Sydney, 20 March, 1883.

We herewith return the documents having reference to the application of Mr. Heinrich Ujhely, of Vienna, for Letters of Registration for an invention entitled "Improvements in the method or process for extracting, refining, and hardening Paraffine Wax," and have the honor to state that we see no objection to the issue of Letters of Registration in this case; but it should be distinctly understood that this extends only to mixtures of "solvents" classed "A" and "B" in the specification, and not to the separate articles named in class "A," as these have long been in use for the purpose stated in the specification.

We have, &c.,

CHARLES WATT.  
EDMUND FOSBERY.

The Under Secretary of Justice.

Sydney, 12 April, 1883.

MEMO. :—We have no objection to urge against the issue of Letters of Registration, the matter to which reference was made in our report being now distinctly understood.

CHARLES WATT.  
EDMUND FOSBERY.

The Under Secretary of Justice.



A.D. 1883, 26th May. No. 1246.

IMPROVEMENTS IN ELECTRIC LAMPS.

LETTERS OF REGISTRATION to Franz Krizik and Ludwig Piette, for  
Improvements in Electric Lamps.

[Registered on the 29th day of May, 1883, in pursuance of the Act 16 Vic. No. 24.]

BY HIS EXCELLENCY THE RIGHT HONORABLE SIR AUGUSTUS WILLIAM FREDERICK SPENCER LOFTUS (commonly called LORD AUGUSTUS LOFTUS), Knight Grand Cross of the Most Honorable Order of the Bath, a Member of Her Majesty's Most Honorable Privy Council, Governor and Commander-in-Chief of the Colony of New South Wales and its Dependencies.

TO ALL TO WHOM THESE PRESENTS SHALL COME, greeting :

WHEREAS FRANZ KRIZIK and LUDWIG PIETTE, both of Pilsen, in the Austrian Empire, have by their Petition humbly represented to me that they are the authors or designers of a certain invention or improvement in manufactures, that is to say, of an invention entitled "Improvements in Electric Lamps," which is more particularly described in the amended specification and the sheet of drawings which are hereunto annexed; and that they, the said Petitioners, have deposited with the Honorable the Treasurer of the said Colony of New South Wales the sum of Twenty Pounds sterling, for defraying the expense of granting these Letters of Registration, as required by the Act of Council, sixteenth Victoria, number twenty-four; and have humbly prayed that I would be pleased to grant Letters of Registration, whereby the exclusive enjoyment and advantage of the said invention or improvement might be secured to them for a period of fourteen years: And I, being willing to give encouragement to all inventions and improvements in the arts or manufactures which may be for the public good, and having received a report favourable to the prayer of the said Petition, from competent persons appointed by me to examine and consider the matters stated therein, and to report thereon for my information, am pleased, with the advice of the Executive Council, and in exercise of the power and authority given to me by the said Act of Council, to grant, and do by these Letters of Registration grant unto the said Franz Krizik and Ludwig Piette, their executors, administrators, and assigns, the exclusive enjoyment and advantage of the said invention or improvement, for and during the term of fourteen years from the date hereof; to have, hold, and exercise unto the said Franz Krizik and Ludwig Piette, their executors, administrators, and assigns, the exclusive enjoyment and advantage thereof, for and during and unto the full end and term of fourteen years from the date of these present next and immediately ensuing, and fully to be complete and ended: Provided always, that if the said Franz Krizik and Ludwig Piette shall not, within three days after the granting of these Letters of Registration, register the same in the proper office in the Supreme Court, at Sydney, in the said Colony of New South Wales, then these Letters of Registration, and all advantages whatsoever hereby granted, shall cease and become void.

In witness whereof, I have hereunto set my sign manual, and have caused the present Letters of Registration to be sealed with the seal of the said Colony of New South Wales, at Government House, Sydney, in New South Wales, this twenty-sixth day of May, in the year of our Lord one thousand eight hundred and eighty-three.

[ l. s. ]

AUGUSTUS LOFTUS.

*Improvements in Electric Lamps.*

SPECIFICATION of FRANZ KRIZIK and LUDWIG PIETTE, both of Pilsen, in the Austrian Empire, for an invention entitled "Improvements in Electric Lamps."

THIS invention relates to electric lamps, and is designed to provide improved means for effecting automatically the regulation of the distance apart of the carbon rods or conductors, without the aid of clock-work or other like mechanism, by the use of a solenoid or solenoids, having a core made as hereinafter described.

According to this invention, I arrange in an electric lamp a solenoid coil with an iron core of a tapering shape, and free to slide lengthwise within the coil, this core carrying at its thickest end one of the carbons of the lamp. The iron core being of a tapering shape, and its lower thickest end being connected with one of the carbons, whilst the upper pointed end passes through the solenoid coil, a greater attraction will be exerted on the lower thicker part than on the upper thinner part of the tapering iron core when a current passes through the solenoid coil, and the core will therefore then be drawn upwards through the solenoid coil.

The said tapering iron core carrying the upper carbon is connected by cords and pulleys with a frame carrying the lower carbon, and the two arrangements are so balanced that as long as no current passes through the lamp the weight of the iron core with the upper carbon will overcome the weight of the frame with the lower carbon, and the carbon points will then touch each other.

When, however, a current passes through the lamp it flows also through the solenoid coil, and will cause the said coil to exert a force having the tendency to draw up the tapering iron core, and so separate the carbons. But this can take place only when the attractive force of the solenoid coil is sufficient to overcome the weight of the iron core balancing the lower frame. When this is the case the iron core will be drawn up until the weakening of the current caused by the formation of the voltaic arc between the carbons is such that the attraction and the weight balance each other. When the current becomes still weaker by the consumption of the carbons increasing the distance between them the weight of the iron core will overcome the attraction of the solenoid coil, and the core will sink, so as to bring the carbons nearer together. In this manner the two forces constantly balance each other, and keep the carbons the proper distance apart.

In order to increase the delicacy of the adjusting solenoid its coil is wound step by step to a larger diameter upwards, and in the spaces given by these steps is wound an opposite coil of high resistance connected in a shunt or by pass to the lamp circuit, this latter coil having the effect of weakening the former coil.

Fig. 1 of the accompanying drawings is a side view of a lamp according to this invention, and fig. 2 is a transverse section. A frame, A B C D, carrying the lower carbon K<sup>1</sup>, is guided by rollers r<sup>1</sup> r<sup>1</sup>, and suspended by non-conducting cords which pass over pulleys R R, and are attached to the lower part of a brass tube, S. This tube is guided by rollers r r; it carries the upper carbon K, and has within it the taper iron core C. The coil of large wire Z is wound by steps, as shown in fig. 2, and the coil of fine wire Y is oppositely wound in the spaces of the steps. When the lamp is in action the current entering at the + post passes by the rollers r r to the tube S, thence through the upper carbon K, the voltaic arc, the lower carbon K<sup>1</sup>, the frame A B C D, the rollers r<sup>1</sup> r<sup>1</sup>, and their supports m m, to the stationary framing of the lamp, then through the coil Z to the — post. The upper carbon K is maintained at the required distance from the lower carbon K<sup>1</sup> by the attraction of the solenoid coil Z on the taper core C, and by the weight of the frame A B C D and lower carbon drawing it upwards in opposition to the weight of the core C and tube S acting downwards. When the distance of the carbons, and consequently the resistance of the arc, is too small, the larger quantity of current passing through the coil Z increases its attractive power, causing the carbon K to ascend. When the distance of the carbons, and consequently the resistance of the arc, is too great, the attractive power of the coil Z is diminished, not only by the reduction of the current passing through it, but also by the weakening influence of the opposite coil Y, which being in a by-pass receives an increased amount of current, and the carbon K descends. Owing to the tapering shape of the core C, the action above described remains practically uniform, notwithstanding its varying position as the carbons are consumed.

Having thus described the nature of the said invention, and in what manner the same is to be performed, I claim,—

First—The herein-described method of regulating the arc of an electric lamp, by the attractive influence of a solenoid coil on a tapering iron core attached at its large end to the holder of one of the carbons of the lamp, and partly balanced by the other carbon and its holder.

Second—The construction of electric arc lamp with regulating solenoid and tapering core, substantially as herein described.

In witness whereof, we, the said Franz Krizik and Ludwig Piette, have hereunto set our hands and seals, this twenty-fifth day of January, one thousand eight hundred and eighty-three.

Witness,—W. S. BAYSTON,  
Clerk to Edwd. Waters, Patent Agent, Melbourne.

FRANZ KRIZIK.  
LUDWIG PIETTE.  
By their Agent, EDWD. WATERS.

We would also have it understood that we are aware that Letters of Registration were, on the twenty-sixth day of August, one thousand eight hundred and eighty-two, granted to Mr. James Fyfe, for an invention entitled "Improvements in Electric Lamps," and entered of record in the Supreme Court, No. 1,113, and that we do not claim to be the inventor of any part or parts thereof.

For the Applicants,

EDWD. WATERS.  
FRED. WALSH.

Sydney, 21 March, 1883.

This

---

*Improvements in Electric Lamps.*

---

This is the amended specification referred to in the annexed Letters of Registration granted to Franz Krizik and Ludwig Piette, this twenty-sixth day of May, A.D. 1883.

AUGUSTUS LOFTUS.

---

REPORTS.

---

Sir,

Sydney, 8 February, 1883.

We do ourselves the honor to report, in reply to your blank cover, 29th ultimo, No. 1,670, that we find the claims of Messrs. Franz Krizik and Ludwig Piette for the registration of an invention entitled "Improvements in Electric Lamps" closely resemble those of a previous registration granted to Mr. James Tyfe; we do not therefore recommend the prayer of Messrs. Krizik and Piette's Petition.

We have, &amp;c.,

E. C. CRACKNELL.  
GOTHER K. MANN.

The Under Secretary of Justice.

Sir,

Sydney, 12 March, 1883.

We do ourselves the honor to report, in reply to your blank cover of the 8th instant, No. 2,169, *re* Krizik and Piette's further application for the registration of "Improvements in Electric Lamps," that with the insertion of the words before the claim as set forth in Mr. Waters's letter of the 21st ultimo, we are of opinion the prayer of Messrs. Krizik and Piette's Petition may now be granted.

We have, &amp;c.,

E. C. CRACKNELL.  
GOTHER K. MANN.

The Under Secretary of Justice.

Sir,

Sydney, 6 April, 1883.

We do ourselves the honor to report, in reply to your further communication, 28th March, No. 3,937, transmitting Messrs. Krizik and Piette's amended specification and claim, that we are of opinion the prayer of the Petitioners may now be granted.

We have, &amp;c.,

E. C. CRACKNELL.  
GOTHER K. MANN.

The Under Secretary of Justice.

---

[Drawings—one sheet.]

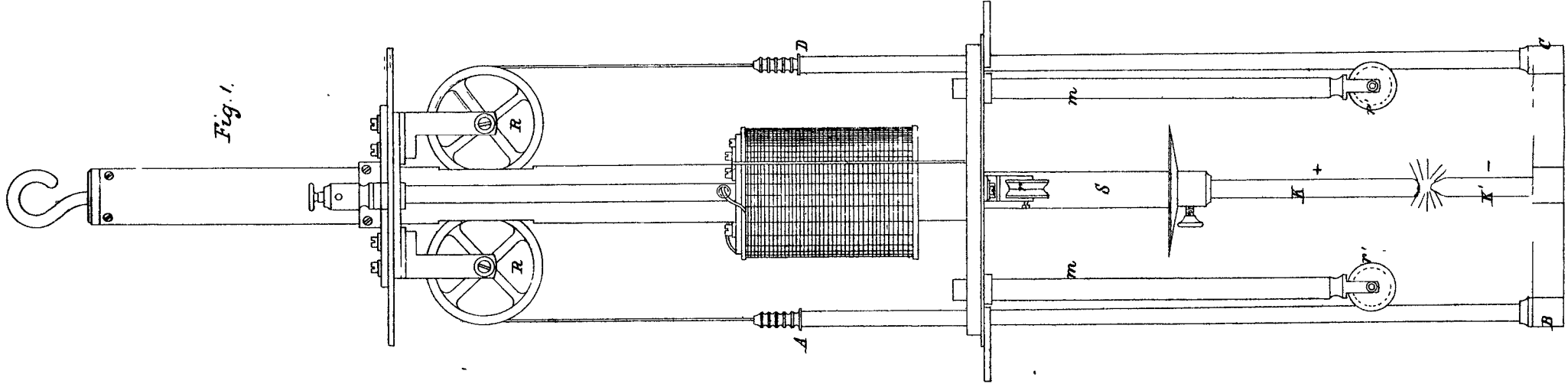


Fig. 1.

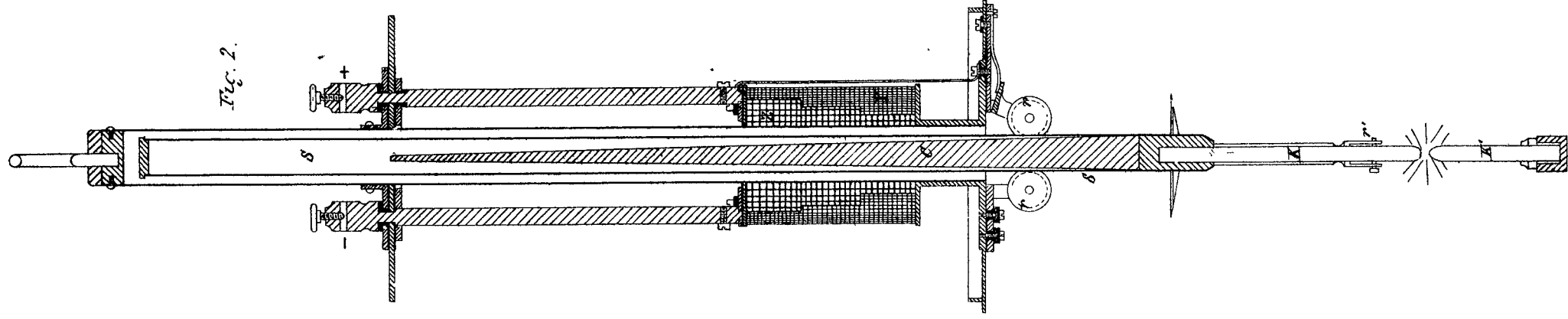


Fig. 2.

*This is the Sheet of Drawings referred to in the annexed  
 Letters of Registration granted to Franz Krzyk and  
 Ludwig Plette, this twenty sixth day of May, A.D. 1883.  
 Augustus Loftus.*



A.D. 1883, 26th May. No. 1247.

**AN IMPROVED CLINOMETER-COMPASS AND AN IMPROVED APPARATUS FOR  
READING ITS INDICATIONS.**

LETTERS OF REGISTRATION to Ebenezer Farie Macgeorge, for an improved  
Clinometer-compass and an improved apparatus for reading its indications.

[Registered on the 29th day of May, 1883, in pursuance of the Act 16 Vic. No. 24.]

BY HIS EXCELLENCY THE RIGHT HONORABLE SIR AUGUSTUS WILLIAM FREDERICK SPENCER LOFTUS  
(commonly called LORD AUGUSTUS LOFTUS), Knight Grand Cross of the Most Honorable Order of  
the Bath, a Member of Her Majesty's Most Honorable Privy Council, Governor and Commander-in-  
Chief of the Colony of New South Wales and its Dependencies.

TO ALL TO WHOM THESE PRESENTS SHALL COME, greeting :

WHEREAS EBENEZER FARIE MACGEORGE, of St. James' Park, Hawthorn, in the Colony of Victoria, gentleman, hath by his Petition humbly represented to me that he is the author or designer of a certain invention or improvement in manufactures, that is to say, of an invention entitled "An improved Clinometer-compass and an improved apparatus for reading its indications," which is more particularly described in the specification and the sheet of drawings which are hereunto annexed; and that he, the said Petitioner, hath deposited with the Honorable the Treasurer of the said Colony of New South Wales the sum of Twenty Pounds sterling, for defraying the expense of granting these Letters of Registration, as required by the Act of Council, sixteenth Victoria number twenty-four; and hath humbly prayed that I would be pleased to grant Letters of Registration, whereby the exclusive enjoyment and advantage of the said invention or improvement might be secured to him for a period of fourteen years: And I, being willing to give encouragement to all inventions and improvements in the arts or manufactures which may be for the public good, and having received a report favourable to the prayer of the said Petition, from competent persons appointed by me to examine and consider the matters stated therein and to report thereon for my information, am pleased, with the advice of the Executive Council, and in exercise of the power and authority given to me by the said Act of Council, to grant, and do by these Letters of Registration grant unto the said Ebenezer Farie Macgeorge, his executors, administrators, and assigns, the exclusive enjoyment and advantage of the said invention or improvement, for and during the term of fourteen years from the date hereof; to have, hold, and exercise unto the said Ebenezer Farie Macgeorge, his executors, administrators, and assigns, the exclusive enjoyment and advantage thereof, for and during and unto the full end and term of fourteen years from the date of these presents next and immediately ensuing, and fully to be complete and ended: Provided always, that if the said Ebenezer Farie Macgeorge shall not, within three days after the granting of these Letters of Registration, register the same in the proper office in the Supreme Court, at Sydney, in the said Colony of New South Wales, then these Letters of Registration, and all advantages whatsoever hereby granted, shall cease and become void.

In witness whereof, I have hereunto set my sign manual, and have caused the present Letters of Registration to be sealed with the seal of the said Colony of New South Wales, at Government House, Sydney, in New South Wales, this twenty-sixth day of May, in the year of our Lord one thousand eight hundred and eighty-three.

[L.S.]

AUGUSTUS LOFTUS.

*An improved Clinometer-compass and an apparatus for reading its indications.*

SPECIFICATION of EBENEZER FARIE MACGEORGE, of St. James' Park, Hawthorn, in the Colony of Victoria, gentleman, for an invention entitled "An improved Clinometer-compass and an improved apparatus for reading its indications."

MY invention consists of an improved Clinometer-compass or altazimuth instrument and of an improved apparatus for reading its indications. When used as a self-acting clinometer-compass or automatic altazimuth instrument it registers within itself the degree of inclination and the magnetic bearing of that inclination, at which it has been allowed for a certain time to repose. This internal registration of gradient and azimuth is such that, by inspection, the clinometer-compass may be replaced after removal in exactly the same position as to gradient and azimuth as that in which it previously reposed.

The first form of this clinometer-compass is as follows:—A phial of glass or any non-magnetic material has at its lower end a transparent bulb or chamber containing a magnetic needle attached beneath a float of glass or other non-corrosive, non-magnetic material, which needle is pivoted on a spike of light material passing downwards through it and touching lightly the bottom of the hollow bulb. This bulb is filled completely with any solidifiant fluid, such as a gelatinous, crystallising, or glutinous solution, thick enough to form a firm jelly or mass on cooling. This needle buoyed up to the point of leaving, the bottom is free to assume the magnetic meridian, while the solution is fluid, but is fixed in that position as it congeals. A contracted glass tube, socketed in the neck of the bulb, keeps the magnet-float from escaping, and while allowing for expansion, keeps the bulb full of fluid, thus preventing the formation of bubbles or free surfaces in the liquid, which would impair the freedom of the needle. I make the needle deep and narrow in proportion to its length, so as to give the utmost directive and defining power within the space it occupies.

At the upper end of said phial is another bulb, from which descends another contracted pipe also socketed in the neck of such bulb and completely filled with the solidifiant fluid. In this fluid I immerse a floating plummet, either rigid or flexible, between float and weight, as shown in drawing, which is so adjusted as to remain perpendicular and lightly touching that which is for the time being the upper part of the bulb, whatever position the phial is made to assume.

The spheroidal form of both upper and lower bulbs prevents the plummet and magnet from touching the sides of their chambers, the plummet from its buoyancy, and the magnet by its weight seeking always the central part of the concave it touches.

The phial itself is also nearly filled with the solidifiant fluid, and thus keeps the air from entering the bulbs through the tubes, while at the same time receiving the surplus or supplying the defect of their contents. These bulb-tubes may be either separate or joined in one, in the position shown, so that accidental air-bubbles will, in being expelled, be unable to pass out of one into the other. Except for difficulty of manufacture I should prefer to join them in one. Figure 1 shows this form of my clinometer-compass, A being the phial, and B and C the respective bulbs, B<sup>1</sup> and C<sup>1</sup> are the contracted tubes; B<sup>2</sup> is the plummet and C<sup>2</sup> the magnetic needle; B<sup>3</sup> and C<sup>3</sup> are the respective floats.

The second form of this instrument is as follows:—The magnet-float is placed in the upper bulb and lightened so that it touches the upper concave and pivots there, while the plummet is placed in the lower bulb is made slightly heavier and rests on the bottom. This form is shown in figure 2, where the plummet and magnetic needle with their respective floats are similarly marked to figure 1.

The third form of the instrument is as follows:—The magnet-float is placed in the upper bulb, the connecting line between float and magnet being either rigid or flexible, and the whole apparatus being delicately adjusted so that if the upper bulb only is visible, the said line will give the perpendicular, and the magnet the meridian by inspection. I still continue the sunken plummet in the lower bulb, and with the addition of a magnet as shown, the readings of which, with the perpendicular line shown, will either check the indications of the upper bulb, or be available if only the lower bulb can be seen. Either of these forms may be used separately if desirable, or both conjointly as described. Figure 3 illustrates this method of construction.

The fourth form of the instrument is illustrated in figure 4, and is as follows:—The upper bulb contains only a bubble *a*, and on the fluid congealing the bulb and attached phial may be replaced at any time at their original inclination by means of a spirit level of the form shown in figure 5, being of glass tubing D, with lower end fitting the bulb squarely and applied centrally to the fixed bubble, while its upper end terminating in a bulb as shown, may be graduated as shown by parallels of latitude at definite intervals, by which means if the barrel of the phial be levelled the angle of inclination may be at once read off with the aid of a micrometer from the spirit bubble in the bulb.

The fifth form of instrument may also be used either with or without a lower bulb containing a magnet.

It is of the form shown in figure 5 and is graduated by the parallel circles as shown, the solidifiant fluid with which it is nearly filled, will, on cooling, leave a bubble under or near one of these parallels, which will, by the use of a micrometer give, at inspection, the angle of solidification. Either of these upper bulbs may be used in conjunction with a lower bulb containing either a magnet or a magnet-plummet as before described.

The fluid used may be of the kind which consolidates within a certain time of its own accord, or it may be of such a nature that, upon the admission of air or any gas, fluid, or solid by a connection under manual control, the contents of the phials will crystallize or solidify, or the same result may be brought about by a detent released by a train of clockwork set to a given time. If the apparatus is used as a hand clinometer-compass, three forms of which are represented by figures 7, 8, and 9, with magnet and plummet, bubble or magnet-plummet, the fluid may be of a non-solidifying nature.

The sixth form of instrument is shown in figure 6, and is as follows:—A box compass is so arranged and suspended in gimball rings, similar to a ship's compass, that it may, when free, hang level, and thus by its face indicate a horizontal plane, and at the same time the magnetic needle be free to indicate the meridian. But when the elastic suspending clips or clamps are allowed by an upward movement of the detent-pin, *h*, to close together they jamb and clamp on the conical bearings, *b b*, and compress the elastic gimball ring, *r r*, so as to contract its diameter there and by so much expand it in the reverse direction and increase its diameter, so that the conical axis affixed to its interior at *t t* are drawn partly out of their conical bearings in the compass box, and thereby clamp and arrest its movement. Attached to one of these, as at *t*<sup>1</sup>, by a stud

*An improved Clinometer-compass and an apparatus for reading its indications.*

stud passing loosely through a hole in its vertical leg, is a stop-lever which is drawn out by the same movement, and turning on its pivot, *p*, presses upwards by its horizontal leg the compass needle off its pivot against the glass horizontal surface or cover, *g*, thus clamping the needle. The whole apparatus being now clamped in the position assumed while in the desired situation, may be removed for inspection, the horizontal surface giving a horizon to which the angle of its containing vessel (of like dimensions with the phials before described) may be referred, and the azimuth indicated by the needle being the direction of the inclination of the said vessel. The sixth form may be used also in a fluid for steadying purposes. The motion of the detent-pin necessary to clamp the apparatus is obtained by clockwork set to a given time like an alarum, and contained in another part of the instrument. It may also be brought about by electric circuit, if required, or by a connecting line or tube actuated by hand at pleasure.

In all these forms, the lower bulb, whether containing magnet alone or plummet alone or magnet-plummet, may, like the upper bulb, whether containing magnet, plummet, or magnet-plummet, be used singly and separately with a fluid either of a consolidating or non-consolidating nature, according as it is used for indirect or direct observation.

In each of this series of modifications my automatic compass-clinometer is to be included in one strong guide-tube impervious to air or water at whatever pressure, and forms one complete apparatus which may be used for testing the deviation of bore holes, for example. Or one or more of any one of these modifications may be used for the same purpose and similarly enclosed, the object of multiplying the number of these clinometer-compasses for any one observation being to obtain a number of readings, from which a mean may be taken, and the object of varying the form of the instrument being to eliminate errors which may be peculiar to any one form by combining the indications of diverse forms in one mean reading, the principal being the same as that upon which all careful surveys are made, viz., by a mean of many readings under diverse circumstances. By a series of observations at progressive measured depths in a borehole (as by a traverse in ordinary survey), the exact path of a borehole, however irregular, may be defined and plotted on paper for future guidance and for the present safety of the drill, which is more frequently injured by the irregularities in the line of bore than by any other cause. At the same time when cores are left standing at the bottom of boreholes, they may be extracted in such a manner as to enable the operator to hold them for inspection on the surface in the exact position they occupied below, and from thence to deduce the dip and strike, or the lay of the strata and reefs from which they are taken, so that it may be inferred to what quarter of the compass and at what underlie any reef pierced by the drill is tending. Figure 10 shows the apparatus for this purpose which is attached to the foremost end of the guide-tube. It consists of a tube whose mouth fits the borehole outside, and the core inside. Its other end which also fits the borehole is fixed eccentrically upon the guide-tube, and the intervening tube or core extractor, which is split and sprung from end to end so as to compress and secure the core, is consequently set at an angle with the core. The operator by means of connecting rods, *r*, pushes the apparatus down straight upon the core, which enters the elastic tube, and is pressed at the same time to one side by its eccentricity. Eventually the core will snap at *m*, and the apparatus after being allowed to rest without further disturbance for some hours, to allow the contents of the phials in the guide-tube to set, is withdrawn, bringing the core up with it. The same operation can be done by a tube of eccentric bore, also slotted on thin sides, see figure 11. Upon unscrewing the core-extractor, *n*, which has a tube attached to its upper end, *p*, containing a phial of the third form, the projecting bulb of which, remaining attached to the core-extractor, will enable that and the core, *g*, it contains to be set in the same position as it was taken from in the borehole. By making a mark upon the core itself through the slot in the tube before withdrawing the core from the core-extractor, it may be readily placed bare in its true position, and by the veins and lamination of it, the angle and bearing of the strata it belonged to may be inferred.

The remainder of the phials in the guide-tube will give a number of readings from which the gradient and azimuth of the borehole itself may be more exactly ascertained.

For reading off the angles of inclination to the horizon or perpendicular, and of magnetic azimuth, as indicated by the consolidated contents of the phials, I employ an apparatus, of which figures 12 and 13 represent respectively a side elevation and plan. A tripod framing, with levelling screws, *fff*, supports a vertical arc, *aa*. Socketed in the centre of this arc is an arm, *r*, carrying a cradle, *c*, which may be either a slotted and spring tube, or clips, or V's, as best suits the shape and size of the compass-clinometer usually inserted in it. This arm carries an index which moves with it round the graduated arc, *aa*, and by which the angle from the vertical may be read. At the extremity of this arm is socketed one member or link of the parallel motion, *pp*, as also the microscopes, *mm*, which are rigidly fixed together and are kept with their axes at right angles, and truly horizontal in all positions of the arm by the parallel motion. Stretched in the inner end of each microscope are hairs placed truly vertical for the purpose of ascertaining that the congealed plummet in the upper bulb of the phial is truly vertical, a result which is attained by revolving the phial in its cradle and by raising or lowering the arm by the tangent-screw and worm, *t*. Revolving horizontally in an axis in the tripod stand is a circular mirror, *l*, in a graduated framing touching the index, *i*. Crossing the mirror at convenient distances and consequently revolving with it are several parallel lines. The phial having been already brought, by the observation of the congealed plummet, to the position in which it became embedded, the mirror is revolved beneath the magnet-bulb or chamber, until the reflection of the magnet is bisected longitudinally by one of the parallel lines. The azimuthal angle read at the index, *i*, is the magnetic azimuth of the inclined phial.

In the case of the fourth and fifth form of the instrument, the microscopes, *mm*, may be modified or altogether dispensed with, according as the spirit-level or the graduations are used to ascertain the inclination of the phial at the time of congelation.

In my clinometer-compass the needle may be wholly immersed, floated, or semi-floated, and touching either a bottom or top surface for both direct observation as in direct surveying or marine operations (in which case the fluid may be non-congealing) and for indirect observations, such as the survey of boreholes, of buried mains, of the sinuosities of sounding-lines, of the gradient of the bottom on which the lead rests, &c., &c., in which latter cases the fluid must be of a congealing or consolidating nature, so as to fix the results



---

*An improved Clinometer-compass and an apparatus for reading its indications.*

---

results for after examination and record. Either clinometer or compass, or both combined, may be used in conjunction with a viscid fluid for the purpose of obtaining a mean of shifting or fluctuating azimuths or gradients, or both during a certain period of time, as for example on board ship to obtain a mean course steered, or a mean inclination of the ship under stress of canvas or driving power.

I do not claim the use of glass tubes or phials containing a congealing or consolidating fluid for the purposes herein described, because that forms part of the invention for which I have already obtained Letters of Registration in the Colony of New South Wales, dated the twenty-sixth day of April, one thousand eight hundred and eighty-two, but what I believe to be new, and therefore claim as my present invention is,—

First.—The improved form of clinometer-compass or altazimuth instrument and its several modifications, as herein described and explained and illustrated by figures 1, 2, 3, 4, 5, 7, 8, and 9, in each of which there is either a bulb at one or both ends of the phials, in the former case the bulb contains a combined clinometer and compass, as at figures 3 and 9, and in the latter case one bulb contains the clinometer, and the other the compass, as at figures 1, 2, 4, and 7, and in every case such bulbs are filled with a fluid in which they float and which sometimes is of a solidifiant or viscid nature and sometimes of a permanently liquid character as described.

Second.—The combination and arrangement of parts forming my improved apparatus for reading the indications of my improved clinometer-compass, as herein described and all illustrated in figures 12 and 13.

Third.—The combination of my improved clinometer-compass with a core-extractor in the manner and for the purpose herein described and as illustrated by figures 10 and 11, and

Fourth.—The modification of my invention in the shape of a box clinometer-compass, as herein described and as illustrated in figure 6.

In witness whereof, I, the said Ebenezer Farie Macgeorge, have hereunto set my hand and seal, this twentieth day of March, one thousand eight hundred and eighty-three.

Witness,—

U. S. BAYSTON,  
Clerk to Edwd. Waters, Patent Agent, Melbourne.

E. F. MACGEORGE.

---

This is the specification referred to in the annexed Letters of Registration granted to Ebenezer Farie Macgeorge, this twenty-sixth day of May, A.D. 1883.

AUGUSTUS LOFTUS.

---

REPORT.

---

Sir,

In reply to your letter of the 22nd ultimo, we have the honor to inform you that we have examined Mr. Ebenezer Farie Macgeorge's application and specification for Letters of Registration for an invention of an "Improved Clinometer-compass and an improved apparatus for reading its indications," and see no reason why his application should not be granted.

Sydney, 3 April, 1883.  
We have, &c.,  
H. C. RUSSELL.  
FRANCIS HIXSON.

The Under Secretary of Justice.

— E. F. MACGEORGE'S PATENT —

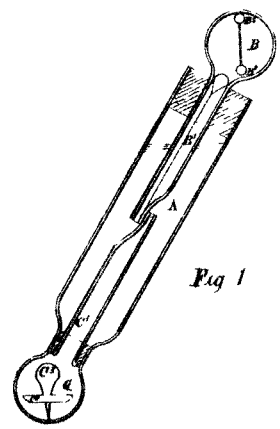


Fig 1

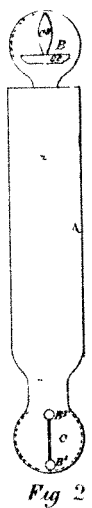


Fig 2

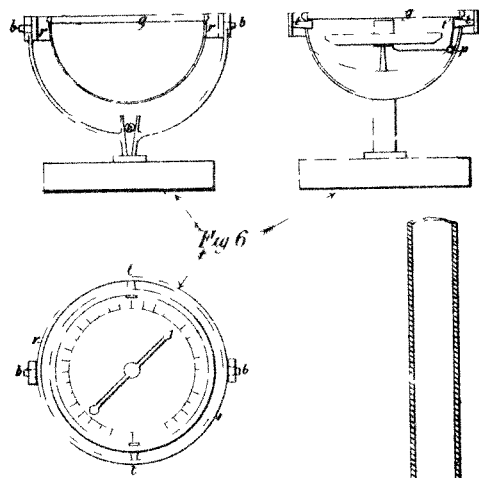


Fig 6

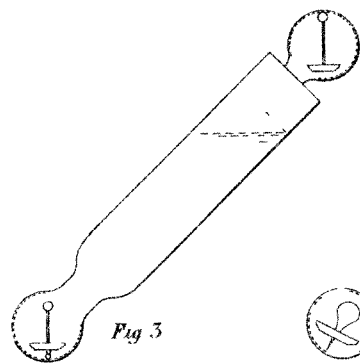


Fig 3

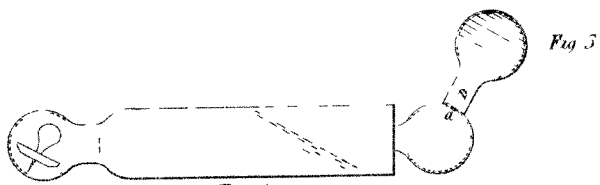


Fig 4

Fig 5

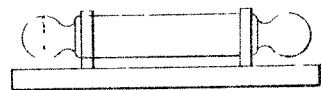


Fig 7



Fig 8

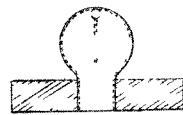


Fig 9

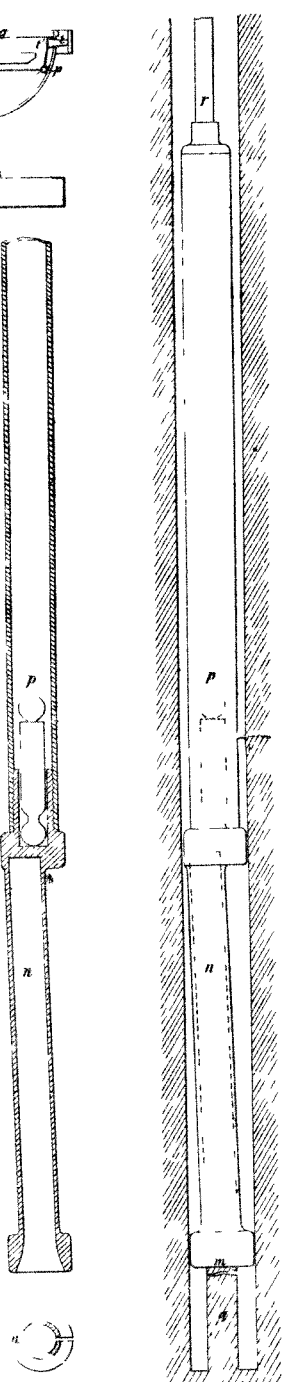


Fig 10

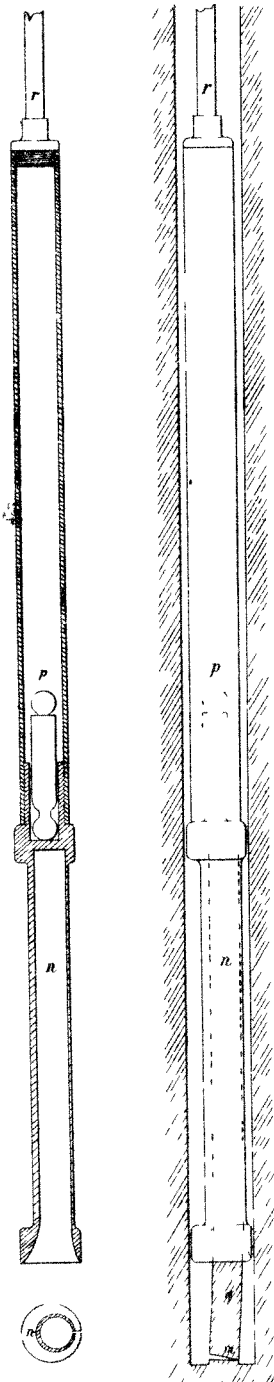


Fig 11

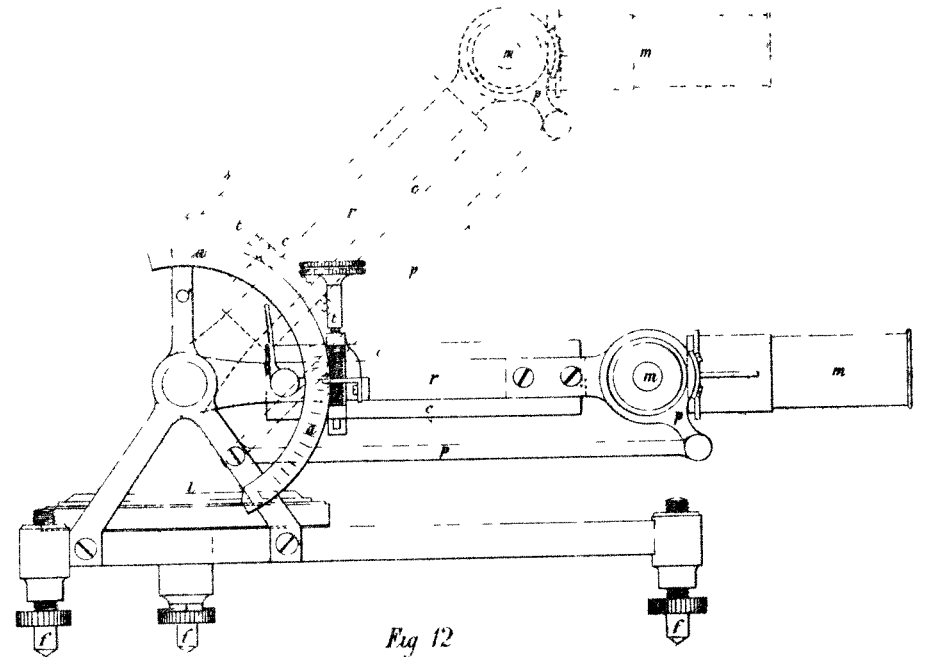


Fig 12

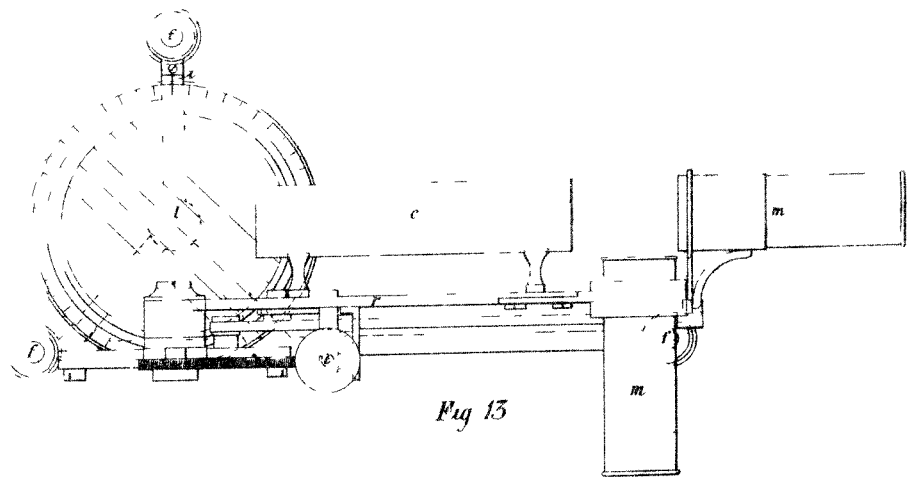


Fig 13

This is the Sheet of Drawings referred to in the annexed Letters of Registration granted to Ebenezer Farie MacGeorge, this twenty sixth day of May, A.D. 1883. Augustus Loftus. (Sig 35.)



A.D. 1883, 26th May. No. 1248.

AN IMPROVED APPARATUS FOR PRODUCING ILLUMINATING AND HEATING AIR GAS.

LETTERS OF REGISTRATION to Relph Cunliff Dixon, for an improved apparatus for producing illuminating and heating Air Gas.

[Registered on the 29th day of May, 1883, in pursuance of the Act 16 Vic. No. 24.]

BY HIS EXCELLENCY THE RIGHT HONORABLE SIR AUGUSTUS WILLIAM FREDERICK SPENCER LOFTUS (commonly called LORD AUGUSTUS LOFTUS), Knight Grand Cross of the Most Honorable Order of the Bath, a Member of Her Majesty's Most Honorable Privy Council, Governor and Commander-in-Chief of the Colony of New South Wales and its Dependencies.

TO ALL TO WHOM THESE PRESENTS SHALL COME, greeting :

WHEREAS RELPH CUNLIFF DIXON, of 16, Change Alley, Pitt-street, Sydney, hath by his Petition humbly represented to me that he is the author or designer of a certain invention or improvement in manufactures, that is to say, of an invention entitled "An improved apparatus for producing illuminating and heating Air Gas," which is more particularly described in the specification and the sheet of drawings which are hereunto annexed; and that he, the said Petitioner, hath deposited with the Honorable the Treasurer of the said Colony of New South Wales the sum of Twenty Pounds sterling, for defraying the expense of granting these Letters of Registration, as required by the Act of Council, sixteenth Victoria number twenty-four; and hath humbly prayed that I would be pleased to grant Letters of Registration, whereby the exclusive enjoyment and advantage of the said invention or improvement might be secured to him for a period of fourteen years: And I, being willing to give encouragement to all inventions and improvements in the arts or manufactures which may be for the public good, and having received a report favourable to the prayer of the said Petition, from competent persons appointed by me to examine and consider the matters stated therein and to report thereon for my information, am pleased, with the advice of the Executive Council, and in exercise of the power and authority given to me by the said Act of Council, to grant, and do by these Letters of Registration grant unto the said Relph Cunliff Dixon, his executors, administrators, and assigns, the exclusive enjoyment and advantage of the said invention or improvement, for and during the term of fourteen years from the date hereof; to have, hold, and exercise unto the said Relph Cunliff Dixon, his executors, administrators, and assigns, the exclusive enjoyment and advantage thereof, for and during and unto the full end and term of fourteen years from the date of these presents next and immediately ensuing, and fully to be complete and ended: Provided always, that if the said Relph Cunliff Dixon shall not, within three days after the granting of these Letters of Registration, register the same in the proper office in the Supreme Court, at Sydney, in the said Colony of New South Wales, then these Letters of Registration, and all advantages whatsoever hereby granted, shall cease and become void.

In witness whereof, I have hereunto set my sign manual, and have caused the present Letters of Registration to be sealed with the seal of the said Colony of New South Wales, at Government House, Sydney, in New South Wales, this twenty-sixth day of May, in the year of our Lord one thousand eight hundred and eighty-three.

[L.S.]

AUGUSTUS LOFTUS.

*An improved apparatus for producing illuminating and heating Air Gas.*

TO ALL WHOM THESE PRESENTS SHALL COME, I, RELPH CUNLIFF DIXON, of Sydney, in the Colony of New South Wales, send greeting :—

WHEREAS I am the author and inventor of an improved apparatus for producing illuminating and heating air gas, and am desirous of obtaining letters patent securing to me Her Majesty's special license that I, my executors, administrators, or assigns, or such others as I my executors, administrators, or assigns, may at any time agree with and no others may use, exercise, or vend, in the Colony of New South Wales, during the term of fourteen years succeeding the date at which this instrument is left at the office of the Colonial Secretary, Sydney; and whereas in order to obtain the said letters patent, it is necessary that I particularly ascertain and describe the nature of my invention and the manner in which its operations are performed :—

Now know ye, that I Relph Cunliff Dixon, do hereby describe the nature of my invention and the manner in which its operations are performed in the following description, reference being made to the drawing plan I herewith, and the letters and figures thereon indicating the parts referred to and here explained.

SPECIFICATION.

I Relph Cunliff Dixon, of Sydney, gentleman, do hereby declare the nature of my invention for improvements in the manufacture of air gas, and the machinery required for the manufacture of the same.

My improvements consist,—

First—In producing saturated air gas, by passing a current of air over or through a heated volatile liquid or hydro-carbon; and thereafter cooling the gas to return any excess of hydro-carbon vapour, so that the air remains just saturated therewith, and can thereafter be conveyed through ordinary gas pipes, and be burned like ordinary illuminating gas through fish-tail, bats-wing, argand, or other gas-burner, and can also be used for cooking or heating stoves, and for gas-engines.

Second—In producing the required current of air by an apparatus set in motion by a portion of the gas produced. The apparatus works automatically, and when no gas is consumed for illuminating or heating purposes, no more is produced than is required to keep the apparatus ready to start.

In carrying out my invention I use the apparatus figured in plan I, and of which the following is a description.

A, gas-engine cylinder or cylinders, to which gas from the gas-holder N is admitted by the pipe I, through the valve G, when the air-holder B is nearly empty, so that the gas-engine cylinder or cylinders being then set in motion the air-holder B is raised and filled. The valve G is actuated by the chain L, attached to the top of air-holder B or other convenient place, so that when the air-holder B sinks, the valve is opened. When the air-holder B is raised, the valve is kept closed by the spring K, which is attached to the side of the cylinder or other convenient place, or instead of a spring the lever of the valve may be kept closed by being suitably weighted as with M.

*h'* is a small valve which is so fixed as to keep open when no pressure is exerted on it in the interior of the cylinder A.

*h*, a small jet gas flame from pipe I controlled by tap H.

*a*, air holes so placed near the top of the cylinder that they are below the piston Y, when the latter is elevated to the top of the gas-engine cylinder. These holes may be about a quarter of an inch in diameter, and five or six in number, but I do not confine myself to that diameter or number, so that they are sufficient to allow of the escape of the products of combustion formed in the gas-engine cylinder or cylinders A, as hereafter described. I prefer to place the gas-engine cylinder or cylinders A directly over the air-holder B, but I do not confine myself to that position, but place it where most convenient, making connection between the piston Y with the air-holder B, by suitable rods, straps, or levers.

B, air-holder the weight of which is so regulated by weights or otherwise, as to force the air into the gas-holder N, through the gas generator Q. The pressure required being about sixteen-tenths of an inch of water pressure, but I do not confine myself to that or any other pressure, using that which I find convenient according to the length of pipe used for conveying the gas, size, and number of burners supplied, &c.

C, valve to let air into holder B. This valve may consist of one or several valves to which the air is admitted through convenient openings in the stand on which B rests, this valve or these valves may either be placed on the bottom as shown on the top of B, or in any other convenient position.

D, air pipe to supply generator, which I prefer to raise through the water in holder B, but which may be taken by a flexible tube from the side or top of B.

E, plug to draw off any water which accidentally gets into pipe D.

FF, water in air-holder B, and generator Q. The surface being marked by dotted lines.

M, valve regulating the pressure of air from air-holder B to the generator Q, which is made self-acting by the chain M, connecting the top or other convenient point of attachment on the gas-holder N, with the lever of valve M, which is so arranged that when the holder N is full the valve is closed. The lever of M which is so arranged that when the holder N is full the valve is closed. The lever of M is weighted at the end as shown; so that this weight opens the valve as the gas-holder N sinks.

Q, generator for holding hydro-carbon used for saturating the air with vapour, and in which the hydro-carbon is heated by the gas jet T, which is regulated by tap U. The hydro-carbon is filled into the generator by the pipe S until it rises to the gauge tap V, whilst the generator can be emptied by the tap V'. The generator contains cylinders of perforated sheet metal or wire net R packed with wick, pumice stone, asbestos, or other suitable porous material, in or through which the volatile hydro-carbon will rise by capillary attraction, and thus expose a large surface to the air of these cylinders, I prefer to use four, but I do not confine myself to that or any other number or to the cylindrical shape, or I may omit these altogether by otherwise extending the liquid surface.

P, worm which is surrounded by the water F in which the gas-holder N floats to condense the excess of hydro-carbon vapour in the gas. The water in the gas-holder becomes slightly heated, but practically I find that this is sufficiently compensated for by the radiation from the external surface, so that the water does not require to be changed.

N,

*An improved apparatus for producing illuminating and heating Air Gas.*

N, gas-holder, the weight of which is so regulated that it supplies about a pressure of about thirteenth-tenths of an inch of water to the gas, so that while it can be raised by pressure supplied from the air-holder B, possesses sufficient weight to force the gas through the pipe O W, but I do not confine myself to that or any other pressure, as the amount required depends on the length and diameter of pipes through which the gas is conveyed, number of burners supplied, &c.

O W, gas-pipe leading the gas to consumption burners.

X<sup>1</sup>, stand of air-holder B.

X<sup>2</sup>, stand of generator Q.

To start the apparatus the generator Q is charged with the hydro-carbon or volatile liquid, to be used by passing it into the pipe marked S, through which it finds its way into the generator Q, until it flows from the gauge tap V, which shows generator is fully charged when the plug on top of pipe S is screwed down, the air-holder B is now raised by hand until the bottom of it comes nearly to the top of water F, when the air passes into it through the valve or valves marked C. The air-holder being thus filled the valve closes, and the holder B by its own weight forces the air through the air-pipe D, and passes the valve M into the generator Q, where it passes over or through the volatile liquid or hydro-carbon, and becomes supersaturated with the hydro-carbon vapour. The supersaturated air then enters the condensing and cooling worm P, which is immersed in the water F of gas-holder where it parts with its excess of hydro-carbon vapour, which is condensed and flows back into the generator Q. The fully, but not over supersaturated air-gas is then received into the gas-holder N, which rises in the water trunk. The gas-holder N by its own weight now forces the gas down the pipe.

O W, the tap *u* is now turned on and the heating flame T beneath the generator is lighted, and also the small flame *h* below the gas-engine cylinder A. The hydro-carbon is heated by the flame T, and the supersaturation of the air by hydro-carbon vapour is ensured.

The burners used for lighting are now lighted, and at first burn with a feeble flame which, however, becomes bright when the liquid or hydro-carbon in generator becomes warm.

As the gas becomes exhausted the gas-holder sinks, and the valve M opens by the weight of the lever, and a fresh supply of air is admitted from air-holder B through the generator, and again fills the gas-holder with gas.

As the air-holder B becomes empty it sinks down carrying with it the piston Y of the gas-engine cylinder A, and when it sinks so low as to open the gas-valve G, the gas enters the cylinder and is there exploded by the jet *h*, through the opening *h'*. This explosion causes the valve over *h'* to close, and raises the piston Y to the top of the cylinder A carrying with it the air-holder B, which is filled with air through the valve or valves C as at first. From the cylinder A, the products of combustion from the explosion escape by the holes *a*, the valve *h'* springs open and the operation goes on as at first.

For supplying six burners each giving a light equal to sixteen candles, I make the air-holder 14 inches in diameter by 18 inches high; the gas-engine cylinder 4 inches in diameter and 18 inches high; the generator 12 inches in diameter and 12 inches in height; the gas-holder 10 inches in diameter and 10 inches high. I do not confine myself to these or any other dimensions as a smaller machine, by a more frequent working of the gas-engine will supply the same number of lights, whilst a larger machine will not require the gas-engine worked so frequently, but these are the dimensions which I prefer.

Having now described the nature of my invention, and the method of producing illuminating and heating gas therewith, I wish it to be understood that I do not claim the use of any particular volatile liquid or hydro-carbon, but use such as are sufficiently volatile to saturate the air, nor do I claim any particular material for the manufacture of the apparatus, although I prefer galvanized iron, copper, or brass. Further, I do not claim any particular disposition of parts in the apparatus. These shown on plan being only those I prefer, and I do not claim the use of wick or other material to expose a large surface to the air in the generator Q.

My claims are,—

First—For the application of heat to the generator through which the air passes, to ensure the supersaturation of the air with hydro-carbon vapour, and also for obtaining this heat by the combustion of a portion of the gas produced.

Second—For the use of a cooling worm to remove any excess of hydro-carbon vapour, which might otherwise be deposited in the pipes.

Third—For obtaining a supply of air for working the machine by the use of a gas-engine cylinder, worked by a portion of the gas produced in the machine.

In witness whereof, I, the said Relph Cunliff Dixon, have hereto set my hand and seal, this fifth day of March, eighteen hundred and eighty-three.

Witness,—JOHN G. S. FAWNS.

R. C. DIXON.

This is the specification referred to in the annexed Letters of Registration granted to Relph Cunliff Dixon, this twenty-sixth day of May, A.D. 1883.

AUGUSTUS LOFTUS.

### REPORT.

Sir,

The application of Mr. R. C. Dixon for Letters of Registration for an invention for "Producing illuminating and heating Air Gas" having been referred to us, we have examined the plans and specification accompanying the same, and have now the honor to report that we see no objection to the issue of Letters of Registration as prayed for.

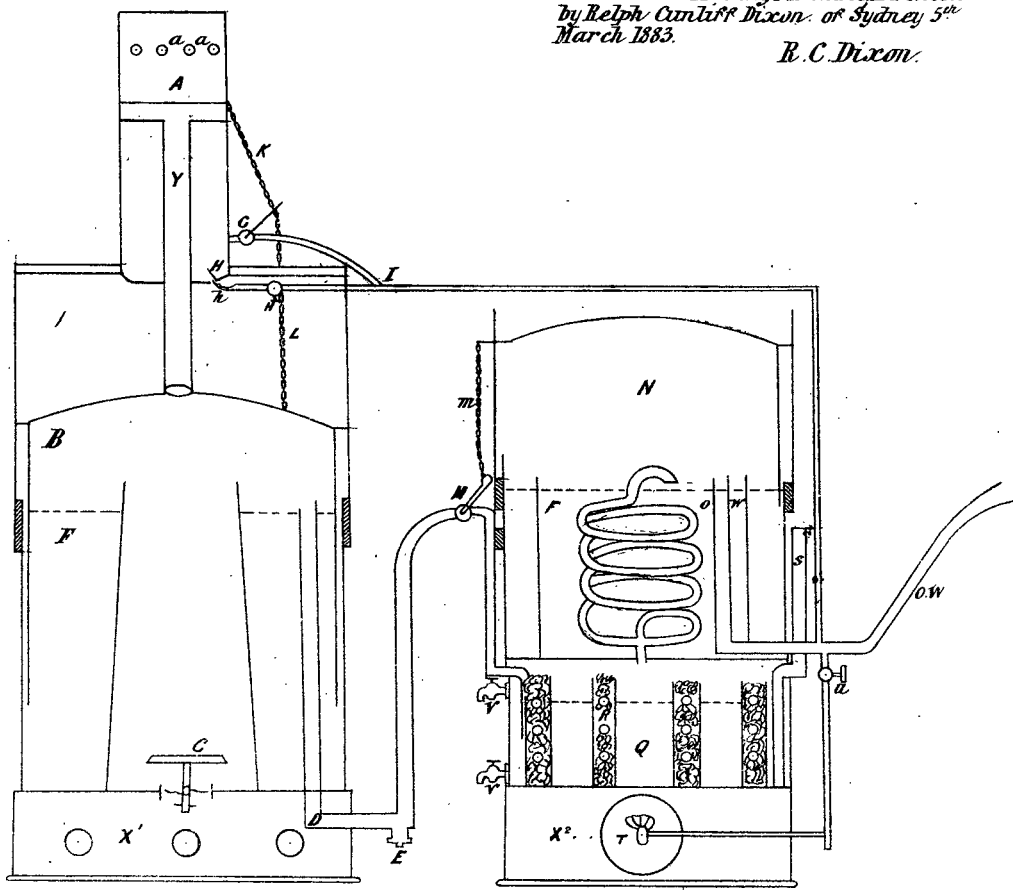
We have, &c.,

JAMES BARNET.  
WILLIAM C. BENNETT.

The Under Secretary of Justice.

*Plan of Gas Making Machine, Invented  
by Relpk Cunliff Dixon, of Sydney 5<sup>th</sup>  
March 1883.*

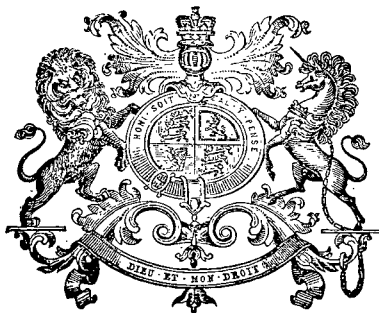
*R. C. Dixon.*



*This is the Sheet of Drawings referred to in the annexed  
Letters of Registration granted to Relpk Cunliff Dixon,  
this twenty-sixth day of May, A.D. 1883*

*Augustus Loftus.*

(Sig. 35-)



A.D. 1883, 26th May. No. 1249.

**STUNTZ'S STOP-MOTION BRICK-MOULDING MACHINE.**

**LETTERS OF REGISTRATION** to William Stuntz, for Stuntz's Stop-motion Brick-moulding Machine.

[Registered on the 29th day of May, 1883, in pursuance of the Act 16 Vic. No. 24.]

BY HIS EXCELLENCY THE RIGHT HONORABLE SIR AUGUSTUS WILLIAM FREDERICK SPENCER LOFTUS (commonly called LORD AUGUSTUS LOFTUS), Knight Grand Cross of the Most Honorable Order of the Bath, a Member of Her Majesty's Most Honorable Privy Council, Governor and Commander-in-Chief of the Colony of New South Wales and its Dependencies.

TO ALL TO WHOM THESE PRESENTS SHALL COME, greeting :

WHEREAS WILLIAM STUNTZ, of Sydney, in the Colony of New South Wales, brickmaker, hath by his Petition humbly represented to me that he is the author or designer of a certain invention or improvement in manufactures, that is to say, of an invention entitled "Stuntz's Stop-motion Brick-moulding Machine," which is more particularly described in the specification and the sheet of drawings which are hereunto annexed ; and that he, the said Petitioner, hath deposited with the Honorable the Treasurer of the said Colony of New South Wales the sum of Twenty Pounds sterling, for defraying the expense of granting these Letters of Registration, as required by the Act of Council, sixteenth Victoria, number twenty-four, and hath humbly prayed that I would be pleased to grant Letters of Registration, whereby the exclusive enjoyment and advantage of the said invention or improvement might be secured to him for a period of fourteen years : And I, being willing to give encouragement to all inventions and improvements in the arts or manufactures which may be for the public good, and having received a report favourable to the prayer of the said Petition, from competent persons appointed by me to examine and consider the matters stated therein and to report thereon for my information, am pleased, with the advice of the Executive Council, and in exercise of the power and authority given to me by the said Act of Council, to grant, and do by these Letters of Registration grant unto the said William Stuntz, his executors, administrators, and assigns, the exclusive enjoyment and advantage of the said invention or improvement, for and during the term of fourteen years from the date hereof ; to have, hold, and exercise unto the said William Stuntz, his executors, administrators, and assigns, the exclusive enjoyment and advantage thereof for and during and unto the full end and term of fourteen years from the date of these presents next and immediately ensuing, and fully to be complete and ended : Provided always, that if the said William Stuntz shall not, within three days after the granting of these Letters of Registration, register the same in the proper office in the Supreme Court, at Sydney, in the said Colony of New South Wales, then these Letters of Registration, and all advantages whatsoever hereby granted, shall cease and become void.

In witness whereof, I have hereunto set my sign manual, and have caused the present Letters of Registration to be sealed with the seal of the said Colony of New South Wales, at Government House, Sydney, in New South Wales, this twenty-sixth day of May, in the year of our Lord one thousand eight hundred and eighty-three.

[L.S.]

AUGUSTUS LOFTUS.

*Stuntz's Stop-motion Brick-moulding Machine.*

## SPECIFICATION.

TO all whom it may concern: Be it known that I, William Stuntz, of Sydney, in the Colony of New South Wales, brickmaker, send greeting:

WHEREAS I am desirous of securing by Royal Letters Patent Her Majesty's license that I, my administrators, executors, or assigns, or such others as I or they should at any time agree with, and no others, should and lawfully might from time to time, and at all times, during the term of fourteen years, to be computed from the day of which this instrument shall be left at the office of the Under Secretary for Justice, make, use, exercise, and vend within the Colony of New South Wales, an invention for making bricks, as more particularly described and ascertained in and by the following statement and description, that is to say:—

My invention consists of a stop-motion brick-moulding machine, which works on the following principle:—

The clay is fed into a pug-mill in the ordinary manner at the top, and is pugged and forced down to bottom of the pug by blades fixed on a centre-revolving spindle. At the bottom there is an aperture the size of brick mould through which the clay is fed into moulds. The moulds are in a circular plate which is revolved by gearing, the gearing being so proportioned that each mould when it comes under the pug comes to a rest, and sufficient time is allowed for it to fill with clay before the revolution is continued, which cessation of revolution is caused by the gearing having a certain amount of blank space in one of the cog wheels, or by the adoption of levers or cambs. The mould, as soon as it is filled with clay and moved on, passes underneath a blank plate, which plate prevents the clay from rising. As the clay swells in the mould it fills up all the space and gives the bricks a sharp edge. As soon as the mould passes from under the blank plate, the bottom of the mould, which is loose and has a spindle roller attached, begins to rise and force the brick out of the mould; this rising motion is applied by the roller partly being on a different level at one side to the other, and as the roller travels up the incline to high side so the brick is forced clear of the mould, when the brick is removed from the die face either by mechanical means or by hand.

And in order that my invention may be fully understood, I now proceed more particularly to describe the same, and for that purpose shall refer to the several figures on the annexed sheet of drawings, the same letters of reference indicating corresponding parts in all figures.

The clay is fed into pug A, which has a revolving shaft in centre fitted with blades. As the shaft revolves it forces the clay down out of aperture at bottom into the mould C in circular plate B, which plate is keyed on to vertical shaft F. The pulley N is driven by the engine, and gives the revolving motion to vertical shaft F through the counter-shaft P, R, and G. The counter-shaft P has a pinion, K, which drives the spur wheel L on shaft R. Keyed on to the same shaft, R, is a wheel, J, with only a portion of its periphery supplied with teeth. When this wheel revolves it gives a momentum to shaft G through wheel H, for the space supplied with cogs at the same time moves the vertical shaft and plate B, each revolution of J being the time that one mould, C, replaces another under the pug A, and also the stoppage of time for filling. Though the mould passes away from under the mouth of pug, the face of brick is still under a slight pressure, as the plate M covers the top of mould until the next brick is filled, which prevents the brick from swelling above the plate, but makes it swell and fill all the corners, and so attain sharp edges. Though I claim for my invention the principle as described, I do not confine myself to that, as I sometimes adopt levers and cambs as shown, J<sup>2</sup> and H<sup>2</sup>, the camb H<sup>2</sup> being revolved a section of a circle by the lever J<sup>2</sup>, and until the opposite end of lever has revolved to the camb the mould-plate B is stationary, the inclined path D is fixed underneath the plate B, and the dies in moulds C are forced up by the spindles and rollers E, which travel along the path D; when the rollers are at the highest point of path D the bottom of mould is flush with the top of plate, so making the brick free to be moved away either by hand or mechanical means.

Having described the nature of my invention, and in what manner the same is to be performed, I claim—

- 1st. The principle of a stop-motion machine, so that the clay can be forced into mould by pug-mill.
- 2nd. The adaptation of wheels with only a portion of the face of wheel supplied with cogs, or the adaptation of levers or cambs to attain the stop motion.
- 3rd. The adaptation of plate to prevent the brick swelling above mould until it has thoroughly filled the corners.
- 4th. The general design of machine with the circular plate fixed on central revolving shaft, with rollers raising brick from mould.

In witness whereof, I, the said William Stuntz, have set my hand and seal, this thirteenth day of March, in the year of our Lord one thousand eight hundred and eighty-three.

Witness—  
OWEN BLACKET.

WILLIAM STUNTZ:

This is the specification referred to in the annexed Letters of Registration granted to William Stuntz, this twenty-sixth day of May, A.D. 1883.

AUGUSTUS LOFTUS.

## REPORT.

Sir,

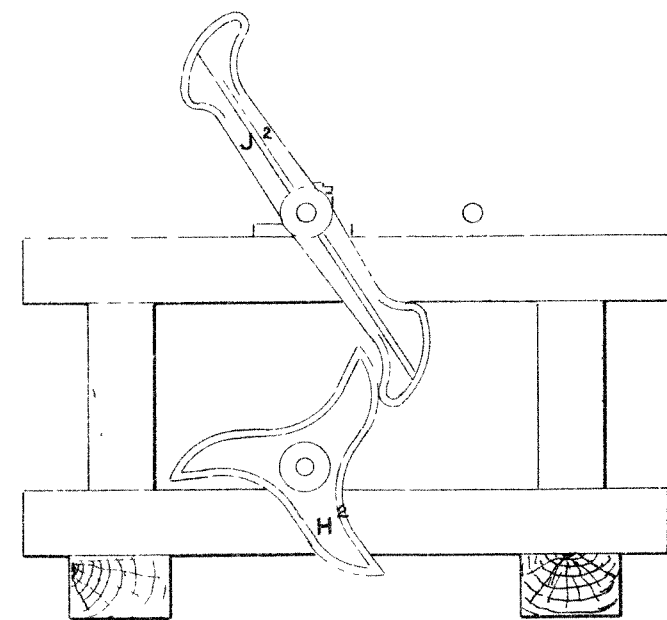
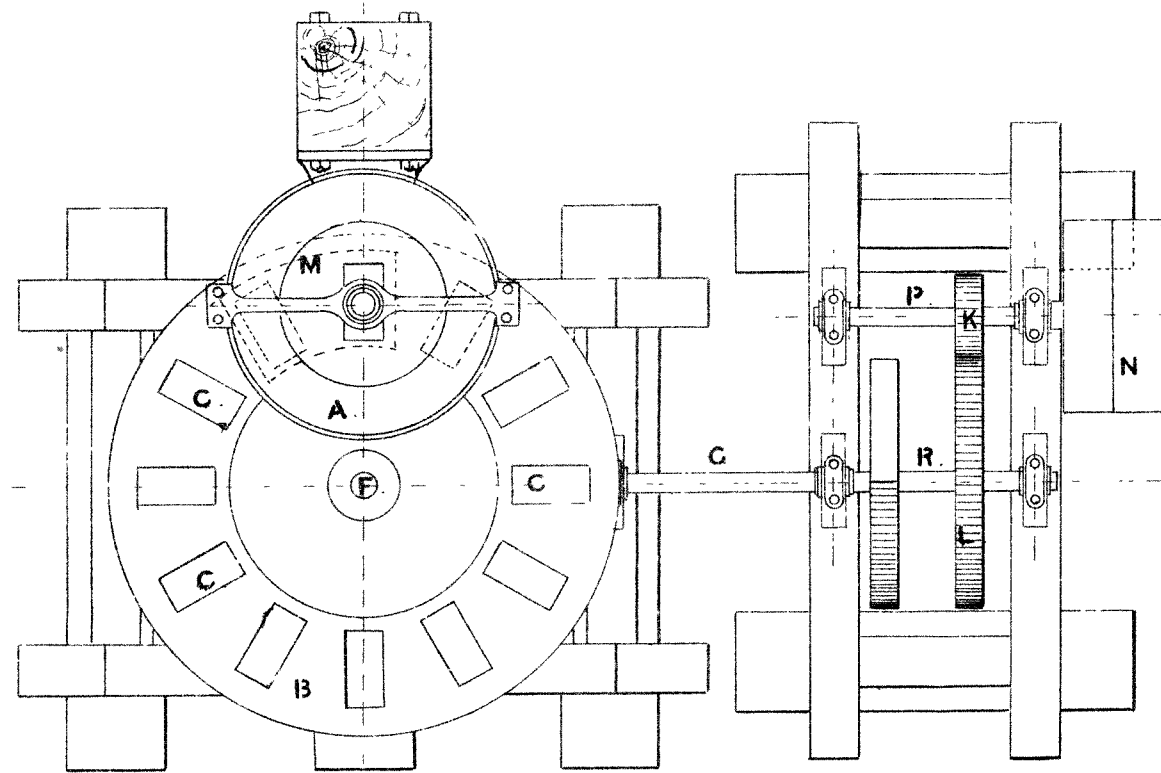
Sydney, 18 April, 1883.

In reply to your blank-cover minute of the 13th March, forwarding application for Letters of Registration for "Stuntz's Stop-motion Brick-moulding Machine," we have to report that we see no reason why such application should not be granted.

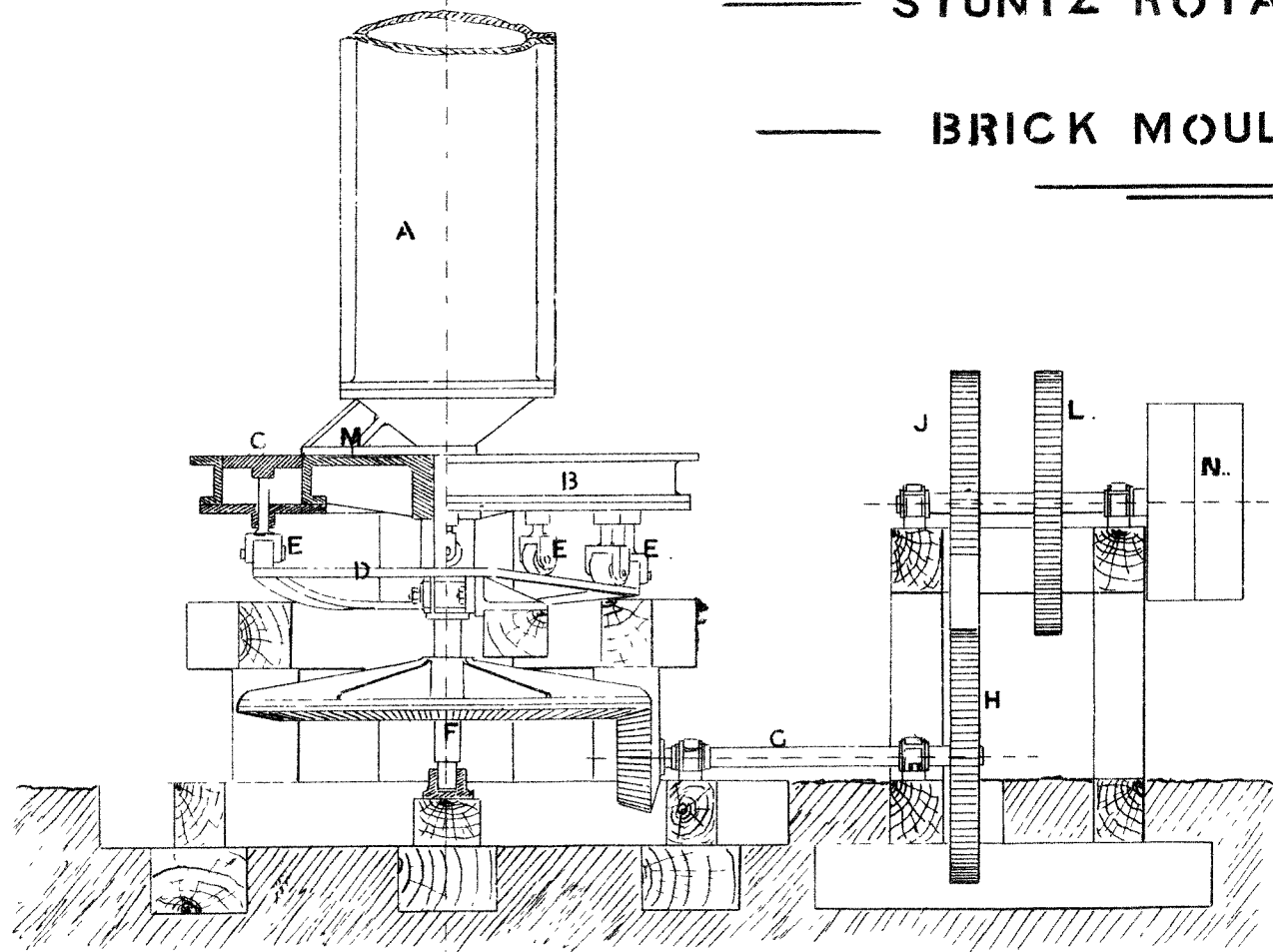
We have, &c.,  
JAMES BARNET.  
WILLIAM C. BENNETT.

The Under Secretary of Justice.

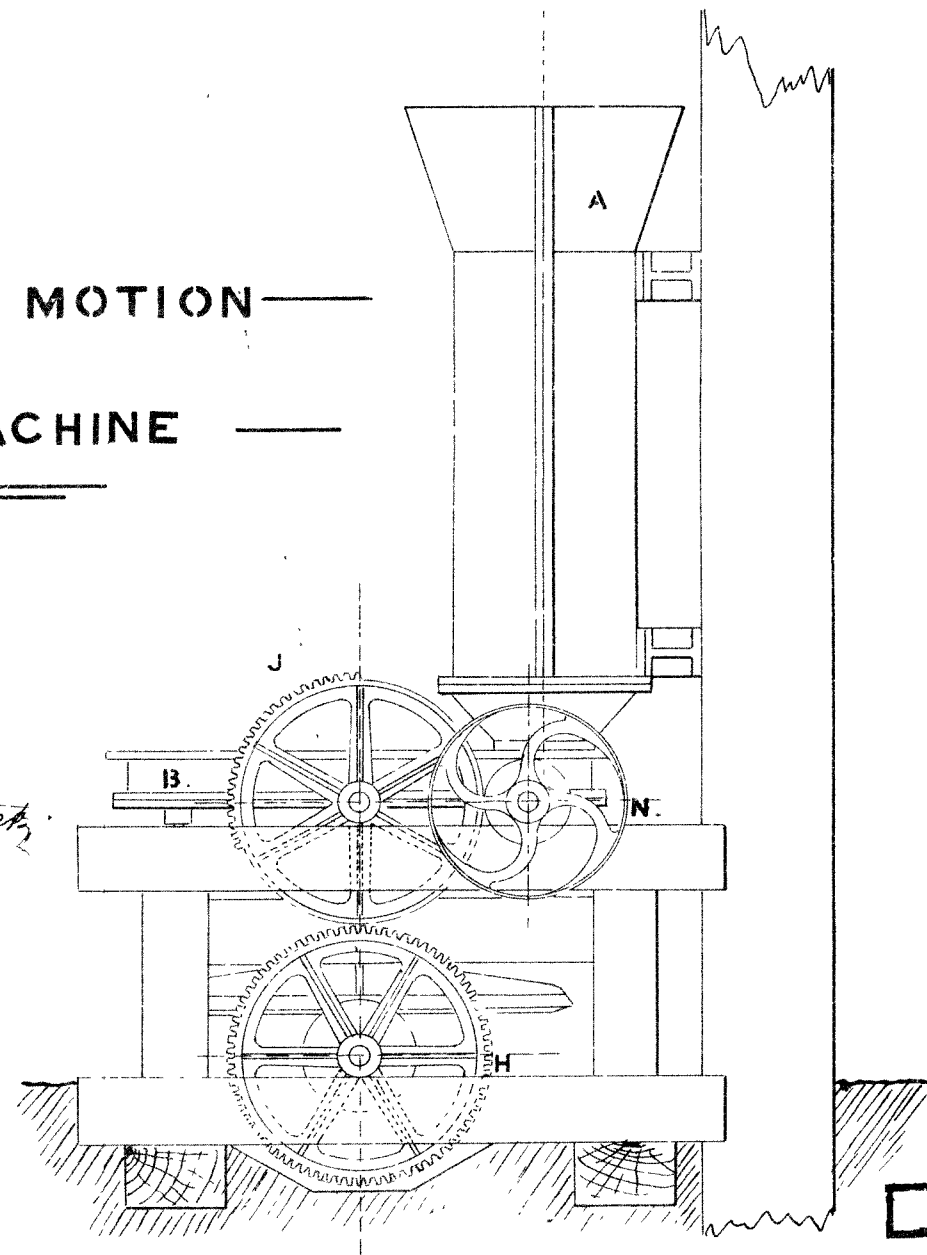




— STUNTZ'S ROTARY STOP MOTION —  
 — BRICK MOULDING MACHINE —



*William Stuntz*



*Sig. 35. This is the Sheet of Drawings referred to in the annexed Letters of Registration granted to William Stuntz, this twenty sixth day of May A. D. 1883.*

*Augustus Loftus.*




---

A.D. 1883, 4th June. No. 1250.

---

**IMPROVEMENTS IN ARC ELECTRIC LAMPS AND REGULATORS.**

**LETTERS OF REGISTRATION to Alexander Leslie Fyfe and John Main, for an invention entitled "Improvements in Arc Electric Lamps and Regulators."**

[Registered on the 5th day of June, 1883, in pursuance of the Act 16 Vic. No. 24.]

---

BY HIS EXCELLENCY THE RIGHT HONORABLE SIR AUGUSTUS WILLIAM FREDERICK SPENCER LOFTUS (commonly called LORD AUGUSTUS LOFTUS), Knight Grand Cross of the Most Honorable Order of the Bath, a Member of Her Majesty's Most Honorable Privy Council, Governor and Commander-in-Chief of the Colony of New South Wales and its Dependencies.

TO ALL TO WHOM THESE PRESENTS SHALL COME, greeting:

WHEREAS ALEXANDER LESLIE FYFE and JOHN MAIN, of London, England, have by their Petition humbly represented to me that they are the authors or designers of a certain invention or improvement in manufactures, that is to say, of an invention entitled "Improvements in Arc Electric Lamps and Regulators," which is more particularly described in the amended specification and the sheet of drawings which are hereunto annexed; and that they, the said Petitioners, have deposited with the Honorable the Treasurer of the said Colony of New South Wales the sum of Twenty Pounds sterling, for defraying the expense of granting these Letters of Registration, as required by the Act of Council, sixteenth Victoria number twenty-four; and have humbly prayed that I would be pleased to grant Letters of Registration, whereby the exclusive enjoyment and advantage of the said invention or improvement might be secured to them for a period of fourteen years: And I, being willing to give encouragement to all inventions and improvements in the arts or manufactures which may be for the public good, and having received a report favourable to the prayer of the said Petition, from competent persons appointed by me to examine and consider the matters stated therein and to report thereon for my information, am pleased, with the advice of the Executive Council, and in exercise of the power and authority given to me by the said Act of Council, to grant, and do by these Letters of Registration grant unto the said Alexander Leslie Fyfe and John Main, their executors, administrators, and assigns, the exclusive enjoyment and advantage of the said invention or improvement, for and during the term of fourteen years from the date hereof; to have, hold, and exercise unto the said Alexander Leslie Fyfe and John Main, their executors, administrators, and assigns, the exclusive enjoyment and advantage thereof, for and during and unto the full end and term of fourteen years from the date of these presents next and immediately ensuing, and fully to be complete and ended: Provided always, that if the said Alexander Leslie Fyfe and John Main shall not, within three days after the granting of these Letters of Registration, register the same in the proper office in the Supreme Court, at Sydney, in the said Colony of New South Wales, then these Letters of Registration, and all advantages whatsoever hereby granted, shall cease and become void.

In witness whereof, I have hereunto set my sign manual, and have caused the present Letters of Registration to be sealed with the seal of the said Colony of New South Wales, at Government House, Sydney, in New South Wales, this fourth day of June, in the year of our Lord one thousand eight hundred and eighty-three.

[L.S.]

AUGUSTUS LOFTUS.

*Improvements in Arc Electric Lamps and Regulators.*

SPECIFICATION of ALEXANDER LESLIE FYFE and JOHN MAIN, both of London, England, for an invention entitled "Improvements in Arc Electric Lamps and Regulators."

The object of this invention is to regulate the feeding of the carbons automatically in the most sensitive and effective manner by the current which actuates mechanism that will maintain the arc constant, and at the same time ensure great steadiness and regularity of the light. This is effected in the following manner:—

A rack is formed on the one side of the carbon-holder, and into this gears a spur-wheel which forms part of a train of wheels terminating in a fly, so that the weight of the carbon and carbon holder causes the spur-wheel to rotate, and by the train of wheels to multiply speed, so that the fly revolves very quickly. On the axis of the fly is a wheel having comparatively smooth periphery, which is a brake surface, and there is a solenoid or electro-magnet which actuates the brake and checks the rotation of the wheels, and consequently the further descent of the carbon and holder. The train of wheels and electro-magnet or solenoid are secured to a cage or movable framework, so that it is free to be raised and lowered by the main solenoid or electro-magnet, which will attract the core or armature on the one side of the lever, and therefore raise the case containing the train of wheels and the upper carbon-holder, and so establish the arc.

Where several lamps are in circuit, we prefer to attach an automatic shunt to each lamp, so that in the event of one becoming extinguished it would not affect the others.

We will now proceed to describe the same with reference to the accompanying drawings.

Figure 1, is a front elevation partly in section. A and B are the terminals secured to the tube C, which at its lower end is secured to the framework C', and D, to which the mechanism is attached; D, is a cover which is capable of being raised to admit of any adjustment being made; it is firmly secured to base of lamp by a screw collar E, working on threads formed on the lower part of the tube C, and thereby prevents the cover from being removed except when it has been unscrewed. F, F, are the rods, and G, G, the cross-bar to which the lower carbon-holder H is secured. I is the upper carbon-holder on the bottom of the rack J, and the other end of the rack works in the tube C. *a* is the first wheel of the train, and *b*, *c*, *d*, *e*, and *f*, the following ones; on the axis of the pinion *f* is the brake-wheel *h*, and fly *g*. *h*<sup>1</sup> is the brake, *h*<sup>2</sup> its counter-balance weight, and *h*<sup>3</sup> the fulcrum.

The electro-magnet or solenoid *h*<sup>4</sup> raises the brake, and allows the carbon-holder to descend. *h*<sup>5</sup> is a stop on a standard forming part of the main frame, which meets the armature or brake only when the cage K is allowed to descend to its lowest point by the cessation of the current in the solenoid or electro-magnet L, whereby the brake is released, and the upper carbon and holder free to run down until it meets the lower carbon in readiness for relighting. K<sup>1</sup> are pegs which serve to guide the cage K. K<sup>2</sup> is a bracket embracing the rack or carbon-holder. The cage is suspended by a link L<sup>6</sup> from the one end of the lever L<sup>3</sup>, which has its fulcrum at L<sup>5</sup> on the bracket *m*. The lever L<sup>3</sup>, is connected to the solenoid armature L<sup>1</sup> by link L<sup>2</sup>, L<sup>4</sup> is a counterweight.

The solenoid or electro-magnet L is in the main circuit, and when the current is passing it attracts its core or armature L<sup>1</sup> and raises the cage K, and with it the rack, thereby establishing the voltaic arc. The electro-magnet *h*<sup>4</sup>, for actuating the brake, is in a shunt circuit, and one end of the wire is connected to the cage K, the other to one end of a resistance coil M, the other end of which is connected to a binding-screw in the main circuit for bridging the arc in the manner as is well understood.

One wheel of the train, say *c*, is provided with ratchet teeth as shown, and a pawl engages with these teeth when the rack or holder is descending, but it allows of the said rack being raised without actuating the whole train of wheels when it is necessary to insert a fresh carbon.

When the resistance of the arc exceeds that of the solenoid and resistance coil, sufficient current passes through to excite the magnet or solenoid *h*<sup>4</sup>, and gradually releases the brake, and the rack will then descend by its own weight until the resistance of the arc is again less than that of the shunt circuit, then the solenoid *h*<sup>4</sup> is inactive, and the brake applied to prevent the further descent of the rack.

Figure 2 is a shunt (forming part of the branch circuit) to provide for any accident which might occur in the lamp whereby the current is directed so as to bridge the arc.

S is the bed-plate of the shunting device, W is the magnet, *y* is the armature mounted on the lever *y*<sup>1</sup>, T is the standard to which it is pivoted at T<sup>1</sup>. The other end of the lever is provided with an adjustable counter-balance weight, or a spring may be substituted for said lever. X is a spring or lever catch; *y*<sup>2</sup> is a projection on the armature, and when the said armature is attracted, this projection comes on the underside of the catch *x*, and is locked in position.

The distance of the armature from the magnet in its normal position is determined by an adjustable stop *y*<sup>3</sup>, which may be on the catch.

Its action is as follows:—Should the carbons from any cause whatever become too far apart so as to endanger the breaking of the arc, and consequently interfering with other lamps which may be in circuit, as more of the current is thus shunted through the branch circuits (which actuate the feed mechanism), the armature *w* is attracted, and consequently locked in position, bridging across the lamp. A resistance equal to the lamp is employed to prevent any disturbance in the general circuit.

Figure 3 shows a holder for the lower carbon. It is arranged on the ball and socket principle, and can be locked in any desired position by the screws *m m*, to ensure the carbons being in line.

The carbons may be maintained in focus by using cords running round pulleys, so as to raise the lower carbon, and the lamp may be constructed to work in various positions by such means.

What we claim is—

First—Supporting and controlling the descent of the upper carbon-holder by a train of wheels actuated by a brake, worked by a solenoid or an electro-magnet in the branch, or it may be in the main circuit, and mounted on a cage, which latter is capable of being raised or lowered by a solenoid or electro-magnet in the main circuit for establishing the voltaic arc, substantially as described and illustrated.

Second—The combination of suspended cage K, and solenoid or electro-magnet L, in electric lamps where the carbon-holder or rack is retained or released by automatic brake mechanism, substantially as described and illustrated.

Third—

*Improvements in Arc Electric Lamps and Regulators.*

Third—The actuation of the cage by the solenoid or electro-magnet in the main circuit together with that of the electro-magnet or solenoid in the shunt circuit for controlling the brake, said brake mechanism acting independently of the movement of the cage, substantially as described and illustrated.

Fourth—In shunting devices, the locking of the armature, substantially as described and illustrated with reference to Figure 2.

Fifth—The method and means for securing the carbons and at the same time allowing of the adjustment of the same in position, substantially as described and illustrated with reference to Figure 3.

Sixth—The general arrangement and mode of operation of electric arc lamp regulators or any mere modification thereof, all substantially as and for the purposes herein set forth.

In witness whereof we have hereto set our hands.

ALEXANDER LESLIE FYFE.

JOHN MAIN.

(by their agent, EDWD. WATERS, per F.W.)

This is the amended specification referred to in the annexed Letters of Registration granted to Alexander Leslie Fyfe, and John Main this fourth day June A.D. 1883.

AUGUSTUS LOFTUS.

### REPORTS.

Sir,

Sydney, 28 December, 1882.

We do ourselves the honor to state, in reply to your blank cover communication of the 19th instant, No. 13,970, transmitting Messrs. Alexander Leslie Fyfe, John Main, and Robert Bowman's Petition for the registration of "Improvements in and connected with Dynamo-electric, Magneto-electric, and Electro-magnetic Machines and Motors, and in Arc Electric Lamps and Regulators," that the specification and claim combine two distinct inventions, and as such combination materially complicates the recorded detail of registered inventions, we suggest that the applicants be requested to revise their specification inasmuch as that the portion pertaining to "Dynamo-Electric and Electro-Magnetic Machines, &c.," as set forth in claims one to five, forms a distinct registration from that portion relating to "Electric Lamps and Regulators," as set forth in claims six to eleven inclusive.

We have, &c.,

E. C. CRACKNELL.

GOTHER K. MANN.

The Under Secretary of Justice.

Sir,

Sydney, 16 April, 1883.

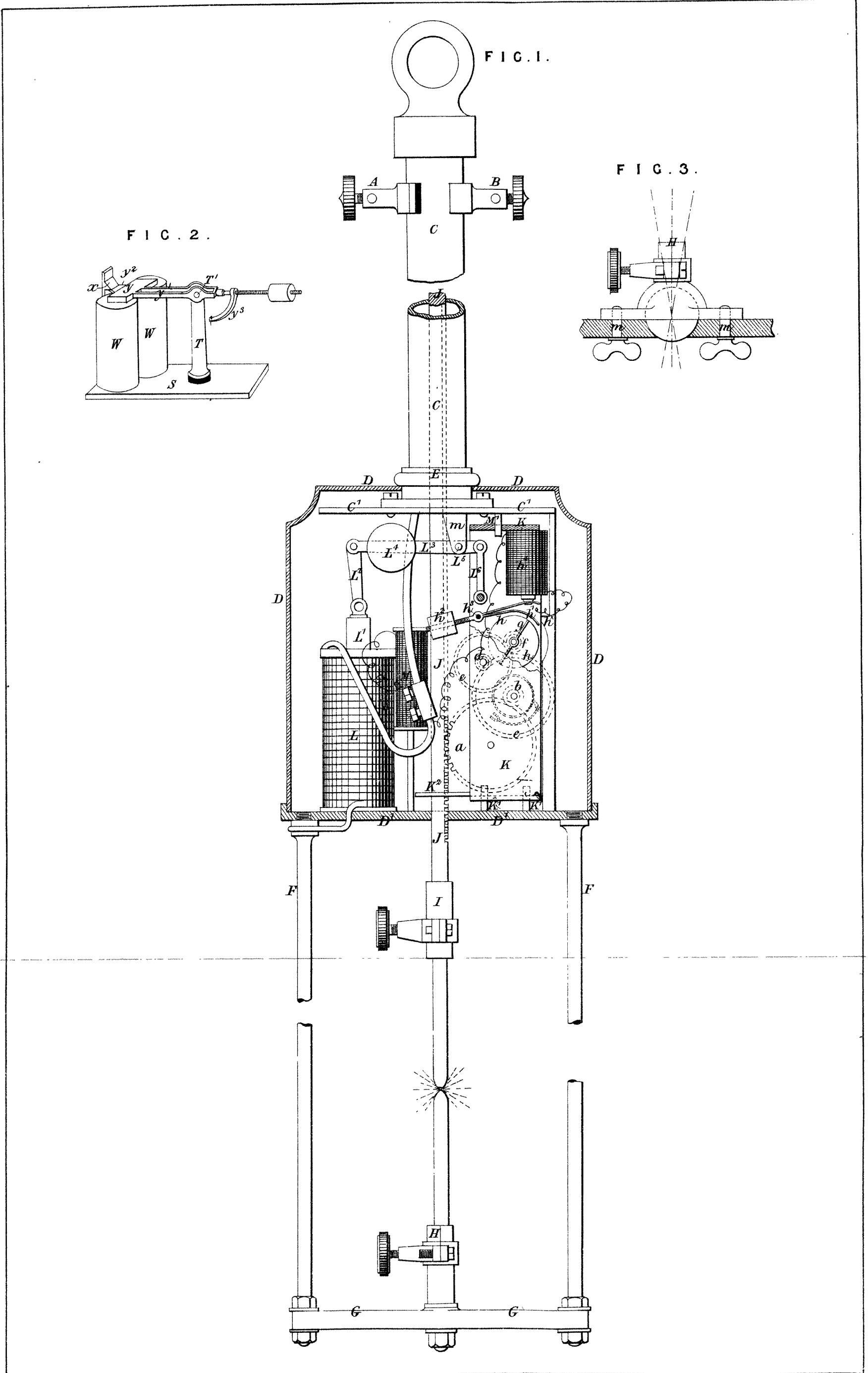
We do ourselves the honour to report in reply to your further blank cover of the 6th instant, No. 4,055. *re* Messrs. Leslie Fyfe and John Main's application for the registration of "Improvements in Electric Lamp Regulators," that we are of opinion the prayer of the petitioners may now be granted in terms of their specification, drawings, and claim now submitted, but we draw attention to the absence of Messrs. Fyfe and Main's or their attorney's signature thereto.

We have, &c.,

E. C. CRACKNELL,

GOTHER K. MANN.

The Under Secretary of Justice.



*This is the Sheet of Drawings referred to in the annexed Letters of Registration granted to Alexander Leslie Fyfe, and John Main, this fourth day of June, A. D. 1883. (Sig. 35.)*  
*Augustus Loftus.*



A.D. 1883, 4th June. No. 1251.

AN IMPROVEMENT IN CENTRIFUGAL PUMPS.

LETTERS OF REGISTRATION to James M'Farlane Robison, Thomas Buchanan Campbell Robison, and Henry Dodds, for an improvement in Centrifugal Pumps.

[Registered on the 5th day of June, 1883, in pursuance of the Act 16 Vic. No. 24.]

BY HIS EXCELLENCY THE RIGHT HONORABLE SIR AUGUSTUS WILLIAM FREDERICK SPENCER LOFTUS (commonly called LORD AUGUSTUS LOFTUS), Knight Grand Cross of the Most Honorable Order of the Bath, a Member of Her Majesty's Most Honorable Privy Council, Governor and Commander-in-Chief of the Colony of New South Wales and its Dependencies.

TO ALL TO WHOM THESE PRESENTS SHALL COME, greeting :

WHEREAS JAMES M'FARLANE ROBISON, THOMAS BUCHANAN CAMPBELL ROBISON, and HENRY DODDS, trading as Robison Brothers and Company, at Flinders-street West, in the City of Melbourne, and Colony of Victoria, engineers, have by their Petition humbly represented to me that they are the authors or designers of a certain invention or improvement in manufactures, that is to say, of an invention entitled "An improvement in Centrifugal Pumps," which is more particularly described in the specification and the sheet of drawings which are hereunto annexed; and that they, the said Petitioners, have deposited with the Honorable the Treasurer of the said Colony of New South Wales the sum of Twenty Pounds sterling, for defraying the expense of granting these Letters of Registration, as required by the Act of Council, sixteenth Victoria, number twenty-four; and have humbly prayed that I would be pleased to grant Letters of Registration, whereby the exclusive enjoyment and advantage of the said invention or improvement might be secured to them for a period of fourteen years: And I, being willing to give encouragement to all inventions and improvements in the arts or manufactures which may be for the public good, and having received a report favourable to the prayer of the said Petition, from competent persons appointed by me to examine and consider the matters stated therein and to report thereon for my information, am pleased, with the advice of the Executive Council, and in exercise of the power and authority given to me by the said Act of Council, to grant, and do by these Letters of Registration grant unto the said James M'Farlane Robison, Thomas Buchanan Campbell Robison, and Henry Dodds, their executors, administrators, and assigns, the exclusive enjoyment and advantage of the said invention or improvement for and during the term of fourteen years from the date hereof; to have, hold, and exercise unto the said James M'Farlane Robison, Thomas Buchanan Campbell Robison, and Henry Dodds, their executors, administrators, and assigns, the exclusive enjoyment and advantage thereof, for and during and unto the full end and term of fourteen years from the date of these presents next and immediately ensuing, and fully to be complete and ended: Provided always, that if the said James M'Farlane Robison, Thomas Buchanan Campbell Robison, and Henry Dodds, shall not, within three days after the granting of these Letters of Registration, register the same in the proper office in the Supreme Court, at Sydney, in the said Colony of New South Wales, then these Letters of Registration, and all advantages whatsoever hereby granted, shall cease and become void.

In witness whereof, I have hereunto set my sign manual, and have caused the present Letters of Registration to be sealed with the seal of the said Colony of New South Wales, at Government House, Sydney, in New South Wales, this fourth day of June, in the year of our Lord one thousand eight hundred and eighty-three.

[L.S.]

AUGUSTUS LOFTUS.

*An improvement in Centrifugal Pumps.*

SPECIFICATION of JAMES M'FARLANE ROBISON, THOMAS BUCHANAN CAMPBELL ROBISON, and HENRY DODDS, trading as Robison Brothers and Company, at Flinders-street West, in the City of Melbourne, and Colony of Victoria, engineers, for an invention entitled "An improvement in Centrifugal Pumps."

It is well known that attempts have been made to avoid the friction of the water on the outer face of the disc of the centrifugal pumps by interposing a guard or chamber between the annular water space and the face of the disc; but this arrangement has been found inefficient, inasmuch as the water has found its way into such chamber. Now, our invention has been designed for the purpose of more efficiently avoiding the aforesaid friction, by preventing all but an insignificant quantity of water from reaching the outer face of the disc, and consists in surrounding the periphery of the disc with an annular throat of suitable size and shape for conducting all the water discharged by the disc into the ordinary water space.

Instead of interposing a chamber or guard between the annular water space and the face of the disc, the latter may be altogether unenclosed, but still our annular throat will be needed.

In the event of any liquid reaching the outer face of the disc, we draw it off by means of a passage leading to the suction pipe.

Referring to the drawings where similar letters indicate similar parts, wherever they occur, figures 1, 2, and 3, represent respectively, horizontal section, vertical section, and elevation of a centrifugal pump fed on both sides; in which A is our annular throat, B the chamber or guard between the disc C and the annular water space D, and E the discharge-pipe.

Figures 4, 5, and 6, represent similar views of a centrifugal pump fed on one side only and having the disc quite unenclosed.

Figures 7 and 8 represent respectively plan and vertical section of a centrifugal pump fed on one side only, constructed with our annular throat, A, and having a passage, B', for draining the water and other liquid that might collect on the outside of the disc into the suction pipe F, through holes, G', in the side of chamber, G.

What we claim is,—

The construction of centrifugal pumps with an annular throat A, surrounding the periphery of the disc C, substantially as herein described and explained and illustrated in our drawings.

In witness whereof, we, the said James M'Farlane Robison, Thomas Buchanan Campbell Robison, and Henry Dodds, have hereunto set our hands and seals, this twentieth day of March, one thousand eight hundred and eighty-three.

Witness,—

U. S. BAYSTON,  
Clerk to EDWD. WATERS, Patent Agent, Melbourne.

JAMES M. ROBISON.  
T. B. C. ROBISON.  
HENRY DODDS.

This is the specification referred to in the annexed Letters of Registration granted to James M'Farlane Robison, Thomas Buchanan Campbell Robison, and Henry Dodds, this fourth day of June, A.D. 1883.  
AUGUSTUS LOFTUS.

## REPORT.

Sir,

In reply to your B.C. minute of the 22nd March, forwarding application of same date from Robison Bros. & Co., for Letters of Registration for "Improvements in Centrifugal Pumps," we have to report that we see no reason why such application should not be granted.

We have, &c.,  
JAMES BARNET.  
WILLIAM C. BENNETT.

The Under Secretary of Justice.

[Drawings—one sheet.]

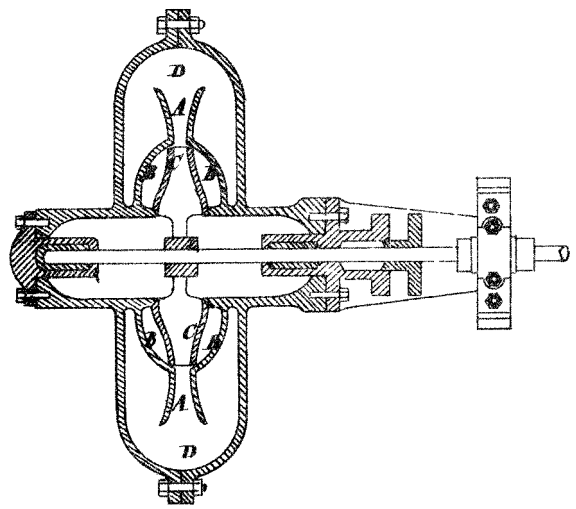


Fig. 1.

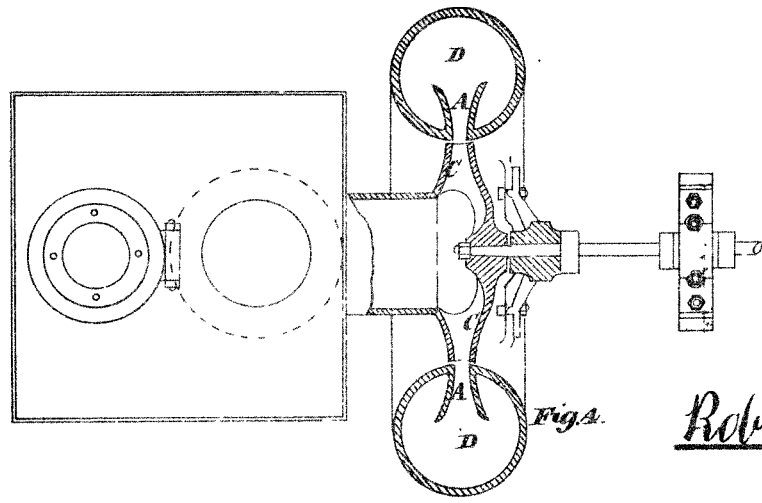


Fig. 4.

Robison Robison and Dodd's Patent

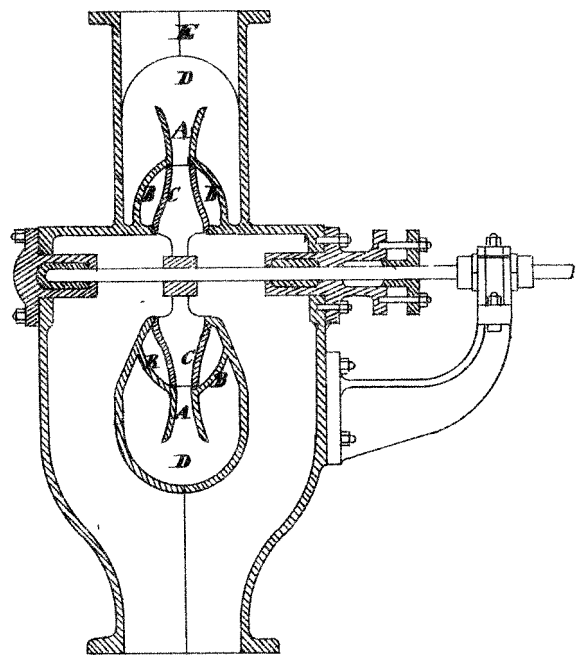


Fig. 2.

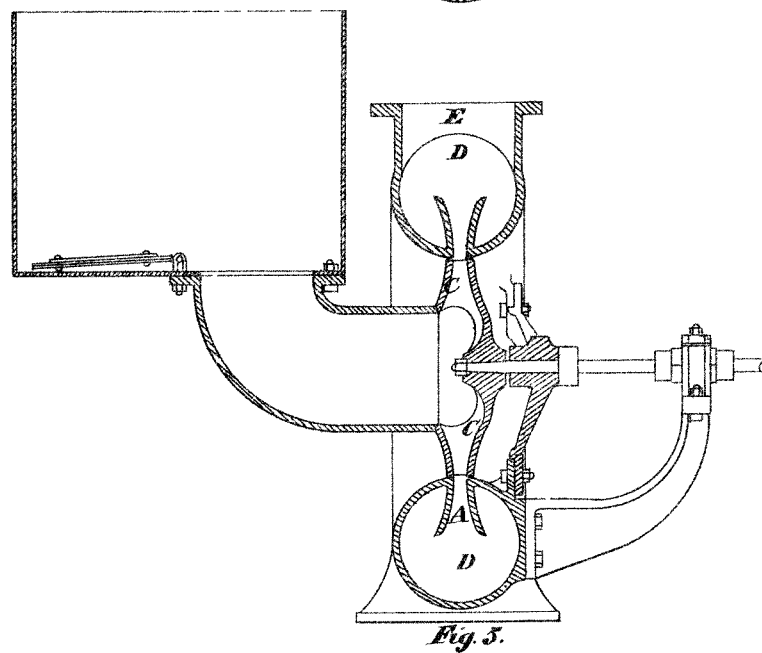


Fig. 5.

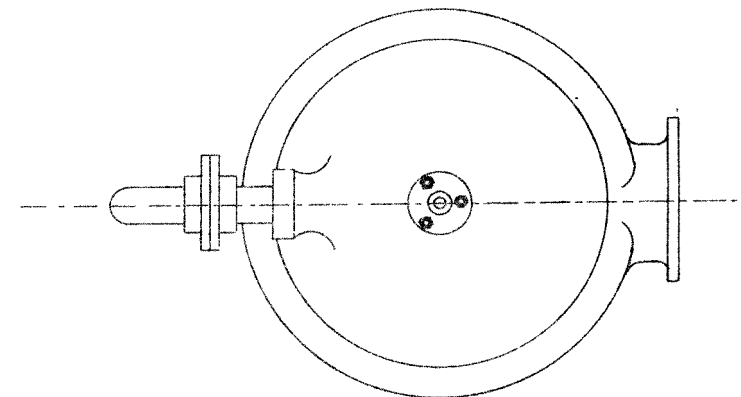


Fig. 7.

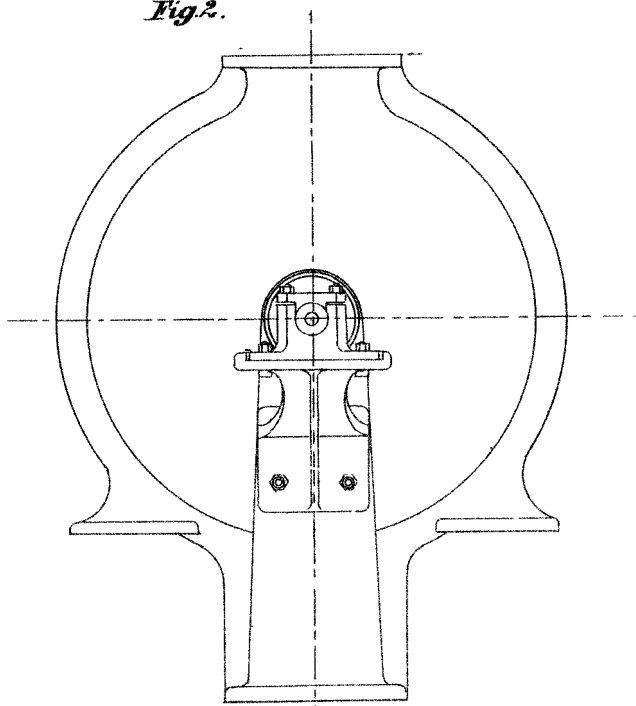


Fig. 3.

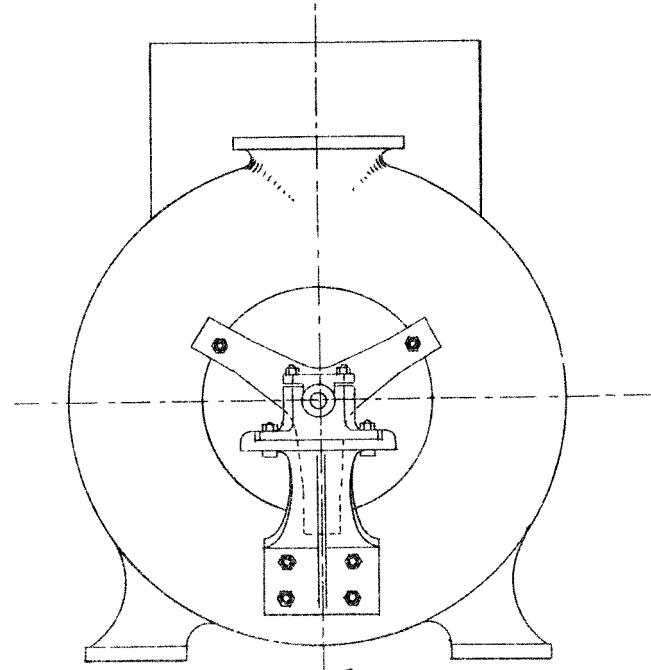


Fig. 6.

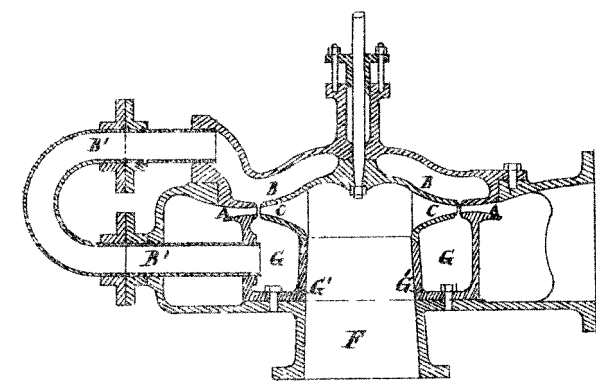


Fig. 8.

This is the Sheet of Drawings referred to in the annexed Letters of Registration granted to James McFarlane Robison, Thomas Buchanan Campbell Robison and Henry Dodds, this fourth day of June, A.D. 1883. Augustus Loftus.






---

A.D. 1883, 4th June. No. 1252.

---

**IMPROVEMENTS IN AND CONNECTED WITH THE REFINING OR PURIFYING OF SUGAR, &c.**

**LETTERS OF REGISTRATION** to Bernhard Heinrich Remmers, and John Williamson, for Improvements in and connected with the Refining or Purifying of Sugar and Saccharine matter.

[Registered on the 5th day of June, 1883, in pursuance of the Act 16 Vic. No. 24.]

BY HIS EXCELLENCY THE RIGHT HONORABLE SIR AUGUSTUS WILLIAM FREDERICK SPENCER LOFTUS (commonly called LORD AUGUSTUS LOFTUS), Knight Grand Cross of the Most Honorable Order of the Bath, a Member of Her Majesty's Most Honorable Privy Council, Governor and Commander-in-Chief of the Colony of New South Wales and its Dependencies.

TO ALL TO WHOM THESE PRESENTS SHALL COME, greeting:

WHEREAS BERNHARD HEINRICH REMMERS and JOHN WILLIAMSON, both of Glasgow, Scotland, have by their Petition humbly represented to me that they are the authors or designers of a certain invention or improvement in manufactures, that is to say, of an invention entitled "Improvements in and connected with the Refining or Purifying of Sugar and Saccharine matter," which is more particularly described in the specification which is hereunto annexed; and that they, the said Petitioners, have deposited with the Honorable the Treasurer of the said Colony of New South Wales the sum of Twenty Pounds sterling, for defraying the expense of granting these Letters of Registration, as required by the Act of Council, sixteenth Victoria, number twenty-four: and have humbly prayed that I would be pleased to grant Letters of Registration, whereby the exclusive enjoyment and advantage of the said invention or improvement might be secured to them for a period of fourteen years: And I, being willing to give encouragement to all inventions and improvements in the arts or manufactures which may be for the public good, and having received a report favourable to the prayer of the said Petition from competent persons appointed by me to examine and consider the matters stated therein and to report thereon for my information, am pleased, with the advice of the Executive Council, and in exercise of the power and authority given to me by the said Act of Council, to grant, and do by these Letters of Registration grant unto the said Bernhard Heinrich Remmers and John Williamson, their executors, administrators, and assigns, the exclusive enjoyment and advantage of the said invention or improvement, for and during the term of fourteen years from the date hereof; to have, hold, and exercise unto the said Bernhard Heinrich Remmers and John Williamson, their executors, administrators, and assigns, the exclusive enjoyment and advantage thereof, for and during and unto the full end and term of fourteen years from the date of these presents next and immediately ensuing, and fully to be complete and ended: Provided always, that if the said Bernhard Heinrich Remmers and John Williamson, shall not, within three days after the granting of these Letters of Registration, register the same in the proper office in the Supreme Court, at Sydney, in the said Colony of New South Wales, then these Letters of Registration, and all advantages whatsoever hereby granted, shall cease and become void.

In witness whereof, I have hereunto set my sign manual, and have caused the present Letters of Registration to be sealed with the seal of the said Colony of New South Wales, at Government House, Sydney, in New South Wales, this fourth day of June, in the year of our Lord one thousand eight hundred and eighty-three.

[L.S.]

AUGUSTUS LOFTUS.

*Improvements in and connected with the Refining or Purifying of Sugar, &c.*

SPECIFICATION of BERNHARD HEINRICH REMMERS and JOHN WILLIAMSON, both of Glasgow, Scotland, for an invention entitled "Improvements in and connected with the Refining or Purifying of Sugar and Saccharine matter."

OUR said invention relates to certain improvements connected with the refining of sugar, which are specially designed to facilitate filtration of sugar liquor and saccharine matter, and render the process much less expensive than hitherto, whilst effecting great saving in the amount and cost of the material employed as a filtering medium, reducing the amount of labour, and allowing a greater quantity than usual of crystallizable sugar to be produced from any fixed quantity and density of sugar liquor.

In the method hitherto adopted for refining and clarifying beet sugar, cane sugar, or mixtures of cane sugar and beet sugar by filtration, the impure or raw sugar dissolved in the "blow-ups," or the sugar juice after expression from the sugar cane or beet, is heated to a certain temperature and is made to descend by gravitation through a vertically arranged series of filtering bags, which have to be frequently washed and renewed, owing to the gum or mucilage contained in the cane-sugar liquor, or in mixtures of cane-sugar and beet-sugar liquor, quickly closing up the interstices of the filterin gcloth, and it has heretofore been found impracticable to utilize the expeditious mode of filtering by means of filter-presses owing to the same cause, unless in sugars filtered from succrate of lime. But by the present improvements the sugar liquor is treated before undergoing filtration, so as to admit of either the old process, or any of the newer methods of filtering being employed with great advantage.

The invention consists essentially in adding to and mixing with the impure sugar dissolved in the "blow-ups," or to and with the dissolved sugar after removal to a separate vessel or tank, or to and with the sugar juice after expression from the cane or beet, a quantity of finely ground or pulverised vegetable charcoal preferably in the form of powder grist, varying in amount according to the ascertained proportion of gum or mucilage in the liquor, from about one-fourth to two and one-half per centum, more or less, by weight of the sugar liquor in the vessel. But we do not limit ourselves to any particular proportion of charcoal to liquor, or the ascertained mucilage therein, nor do we confine ourselves to any precise size of grain in the charcoal used. Very coarsely grained charcoal, and on the other hand, charcoal pulverised like dust or flour, will not as a rule be so effective as charcoal in the form of powder grist. This powdered charcoal when mixed with the sugar liquor, absorbs a very large proportion or nearly all the gum or mucilage as well as a portion of the coloring matter which the liquor contains. The sugar liquor so treated is then filtered either in the usual way, or (as is preferred) by being forced through a filter-press of the kind commonly used for the filtration of beetroot sugars containing a large amount of lime residues, and for the filtration of other like substances. The purified liquor drawn from the filter-bags or press is then ready for the subsequent treatment required for decolorizing, which may consist of passing the filtered sugar liquor through a stratum of animal charcoal. In consequence of the removal of the mucilage and the partial decolorization effected by the previous use of the vegetable charcoal, a larger quantity of sugar liquor will be completely decolorized by an equal amount of animal charcoal in an equal period of time. Besides this advantage, there is the advantage in our invention that the sugar liquors, after being mixed with the vegetable charcoal, require much less filter-cloth (whether in bags or presses) for their filtration than they require when filtered without being so previously treated with vegetable charcoal. When filtered by this rapid method (according to which filtration can be effected at a much lower temperature and greater density than heretofore) the formation of fructose or fruit sugar is also prevented or retarded, and a considerable proportion of the sugar liquor which has been heretofore converted into syrup, is retained as crystallizable sugar, and a gain is effected corresponding to the difference in the value of the sugar saved, and of the syrup which formerly resulted from the process.

The solid residue of the filtering process consisting mainly of charcoal and sugar, gum or mucilage, fibrous material, and coloring matter, is retained in the filter-bags or the filter-press (as the case may be) in the form of solid lumps or cakes; which may be treated for the recovery of the vegetable charcoal and sugar, first, by washing the lumps or cakes with hot water or steam, which is either passed through the lumps or cakes in the filter-bags or filter-press, or used to dissolve the lumps or cakes after they are removed therefrom. The resulting liquor of the washing process is retained for recovery of the sugar contained in it. The solid residue of the lumps or cakes is then treated with a caustic alkali, which dissolves out all the gum or mucilage and coloring matter contained in the pores of the charcoal. After passing this residue through a filter-press, the cakes retained in the press are neutralized by washing them with an acid, preferably sulphurous. The vegetable charcoal is then ready for being used again in the process as before described. Or again, the vegetable charcoal after being freed from all sugar by washing, can be re-burned or revived, in the same manner as animal charcoal is at present revived in refineries. After the vegetable charcoal is taken from the kilns and finely pulverized, it is in a fit state for being used over again.

In the treatment of other saccharine bodies such as glucose, previous to filtration we add from one-fourth to two and one-half per centum (more or less) of vegetable charcoal grist, and filter as hereinbefore described.

Having thus described the nature of our invention, and the mode in which the same is to be carried into effect, we declare that what we claim as our invention is the treatment in the manner and for the purposes before described of sugar liquors with pulverized vegetable charcoal.

In witness whereof, we, the said Bernhard Heinrich Remmers and the said John Williamson, have hereunto set our hands and seals, this second day of February, 1883.

Witness,—

WALLACE FAIRWEATHER, C.E.,  
96, Buchanan-street, Glasgow.

B. H. REMMERS.  
JOHN WILLIAMSON.

This is the specification referred to in the annexed Letters of Registration granted to Bernhard Heinrich Remmers and John Williamson, this fourth day of June, A.D. 1883.

AUGUSTUS LOFTUS.

REPORT.

---

*Improvements in and connected with the Refining or Purifying of Sugar, &c.*

---

REPORT.

---

Sir,

The application of Messrs. Bernhard Heinrich Remmers and John Williamson for Letters of Registration for an invention entitled "Improvements in and connected with the Refining or Purifying of Sugar and Saccharine matter," having been referred to us, we have examined the specification accompanying the same, and have now the honor to report that we see no objection to the issue of Letters of Registration as prayed for.

Sydney, 12 April, 1883.

We have, &c.,  
CHAS. WATT.  
A. LEIBIUS.

The Under Secretary of Justice.

---



A.D. 1883, 4th June. No. 1253.

A NEW SYSTEM OF DISTRIBUTING ELECTRICITY FOR THE PRODUCTION OF  
LIGHT AND POWER.

LETTERS OF REGISTRATION to Lucian Gaulard and John Dixon Gibbs,  
for a new System of Distributing Electricity for the Production of Light and  
Power.

[Registered on the 5th day of June, 1883, in pursuance of the Act 16 Vic. No. 24.]

BY HIS EXCELLENCY THE RIGHT HONORABLE SIR AUGUSTUS WILLIAM FREDERICK SPENCER LOFTUS  
(commonly called LORD AUGUSTUS LOFTUS), Knight Grand Cross of the Most Honorable Order  
of the Bath, a Member of Her Majesty's Most Honorable Privy Council, Governor and Commander-  
in-Chief of the Colony of New South Wales and its Dependencies.

TO ALL TO WHOM THESE PRESENTS SHALL COME, greeting :

WHEREAS LUCIAN GAULARD, of Montague-place, Bedford-square, and John Dixon Gibbs, of  
Bury-treet, St. James, both in the county of Middlesex, England, have by their Petition humbly  
represented to me that they are the authors or designers of a certain invention or improvement in  
manufactures, that is to say, of an invention entitled "A new System of Distributing Electricity for the  
Production of Light and Power," which is more particularly described in the specification and the sheet of  
drawings which are hereunto annexed; and that they, the said Petitioners, have deposited with the  
Honorable the Treasurer of the said Colony of New South Wales the sum of Twenty Pounds sterling,  
for defraying the expense of granting these Letters of Registration, as required by the Act of Council,  
sixteenth Victoria, number twenty-four; and have humbly prayed that I would be pleased to grant  
Letters of Registration, whereby the exclusive enjoyment and advantage of the said invention or  
improvement might be secured to them for a period of fourteen years: And I, being willing to give  
encouragement to all inventions and improvements in the arts or manufactures which may be for the  
public good, and having received a report favourable to the prayer of the said Petition, from competent  
persons appointed by me to examine and consider the matters stated therein and to report thereon for  
my information, am pleased, with the advice of the Executive Council, and in exercise of the power  
and authority given to me by the said Act of Council, to grant, and do by these Letters of Registration  
grant unto the said Lucian Gaulard and John Dixon Gibbs, their executors, administrators, and assigns,  
the exclusive enjoyment and advantage of the said invention or improvement, for and during the term  
of fourteen years from the date hereof; to have, hold, and exercise unto the said Lucian Gaulard and  
John Dixon Gibbs, their executors, administrators, and assigns, the exclusive enjoyment and advantage  
thereof, for and during and unto the full end and term of fourteen years from the date of these  
presents next and immediately ensuing, and fully to be complete and ended. Provided always, that if  
the said Lucian Gaulard and John Dixon Gibbs shall not, within three days after the granting of these  
Letters of Registration, register the same in the proper office in the Supreme Court, at Sydney, in the said  
Colony of New South Wales, then these Letters of Registration, and all advantages whatsoever hereby  
granted, shall cease and become void.

In witness whereof, I have hereunto set my sign manual, and have caused the present Letters of  
Registration to be sealed with the seal of the said Colony of New South Wales, at Govern-  
ment House, Sydney, in New South Wales, this fourth day of June, in the year of our  
Lord one thousand eight hundred and eighty-three.

[L.S.]

AUGUSTUS LOFTUS.

*A new System of Distributing Electricity for the Production of Light and Power.*

SPECIFICATION of LUCIAN GAULARD, of Montague-place, Bedford-square, and JOHN DIXON GIBBS, of Bury-street, St. James, both in the County of Middlesex, England, for an invention entitled "A new System of Distributing Electricity for the Production of Light and Power."

THIS system consists of the employment of an alternating current produced by an electro-dynamo machine and determining by its passage through an unlimited number of electrical generators of special construction the formation of induced currents, of which the quality and the value depend only on the construction of the secondary coils of the said electrical generators.

The currents generated under these conditions are utilized either by lamps to produce light or by magneto-machines to produce motive power.

The principle which is the basis to this system of distribution is the following :—

When an electric current approaches to or recedes from a closed circuit of solenoidal form, it determines in this latter an induced current, without the value of the primary current being in anyway modified; experience shows that the alternation of a primary current gives rise to an induced current under the same conditions as the passage and interruption of the said current.

In further explanation we would compare the phenomenon just mentioned to that produced by the working of magneto-electric machines. In effect, in these latter the induced current is produced, the value of the magnetic field remaining constant, by the approaching of the bobbins to and their receding from the magnetic poles, and experience shows that the value of the current produced is in exact proportion to the speed of passage or rotation.

In the machine of Pixü, which was the first constructed, the current was generated by the rapidity with which the poles were alternatively brought before the bobbin.

In utilizing alternating currents the phenomenon produced in our induction machines may be compared to that produced by the machines of Pixü.

This explained, it is easy to understand the working of our system.

We take an alternating current dynamo-machine constructed in such a manner that the resistance of the inducted system ("induit") is greater than that of the external circuit uniting its two extremities.

Let us suppose the length of this circuit equal to 50 kilometres, we place (see figure 1) upon it at every 500 metres, for instance, a secondary generator constructed in the following manner :—

The secondary generator may be constructed as represented in figure 2.

Upon a central exciting core of soft iron wire is rolled a copper wire of about 3 millimetres diameter and perfectly insulated in 3 rows of superposed spires. On the cylinder thus formed are placed bobbins, on which a cable is wound composed of 6 copper wires of half a millimetre in diameter, each strand being insulated by means of paraffined cotton. The ends of the cable of each bobbin are so placed as to allow of their being grouped for quantity of tension.

These bobbins constitute the secondary coil, to the poles of which are fixed the apparatus of consumption. The first wire, on the other hand, through which the initial current circulates constitutes the primary coil.

A more powerful generator may be formed by means of several columns of bobbins arranged in that case vertically in parallel rows.

The secondary coils of these columns are connected with one another by a central commutator, or preferably the following construction is adopted :—

A cable (see figures 3) is composed of a central copper wire of 4 millimetres diameter, perfectly insulated, around which are placed parallel to its axis, and completely surrounding it, 6 cables each composed of 12 copper wires of half a millimetre diameter, individually insulated with paraffined cotton or other insulating material.

This cable is rolled on a hollow cylinder made of wood, for example, 50 centimetres long and 6 centimetres in diameter, and each layer of spirals is separated from the other by 2 cylindrical segments of iron 2 millimetres thick, and without contact, in order to avoid the creation of heating Foucault currents.

The extremities of the six fine wire cables are united to a commutator, which allows of their being grouped either in tension or quantity.

The object of this disposition is to utilize the radiating inductive action of the inductor formed by the wire of 4 millimetres placed in the centre of the cable, and to prevent the reaction of the spirals composing the inductor on one another.

The columns formed as above described may be placed vertically on a platform in the number proportionate to the power it is desired to give to the machine thus constructed, and the extremities of their inductors are connected with a commutator, so as to allow the passage of the primary current through one or more of the columns.

As is explained above, the extremities of the small wires composing the inducted system ("induit"), and on which is gathered the current destined to be employed, are grouped in tension or in quantity, so as to vary the tension according to the requirements of the consumer. Lastly, in the centre of the columns movable exciting cores enable the graduation of the potential of the current generated on the induced system ("induit").

Now, the primary current in passing through this primary coil is subject to no other modification than that caused by the resistance of this said primary coil; hence the currents generated by the hundred secondary generators placed upon the circuit will have changed the value of the primary current only in proportion to the sum of the resistances of their primary coils, which resistance will be compensated in the construction of the inducted system ("induit") of the primary generator.

Under these conditions it is easy to understand that the number of secondary generators may be indefinitely multiplied upon the circuit, and that, according to the theory explained above, the value of the currents generated (the initial alternating current remaining constant) will depend only on the construction of the secondary coils of the secondary generators.

From which it results that secondary generators of similar construction will give absolutely identical currents, capable of being advantageously employed in telegraphic systems; and thus the problem of the suppression of batteries for telegraphy is solved.

To sum up, we claim in accordance with the law—

---

*A new System of Distributing Electricity for the Production of Light and Power.*

---

First—The privilege of exclusively working our process of distribution characterised by the following points as above explained: The employment of an alternating current of high tension for the generation, on an unlimited number of secondary generators, of induced currents individually utilized either for the production of light or motive power.

Second—The system of electric distribution such as is laid down in the foregoing statement.

Third—The special construction, as described, of secondary generators designed to produce this result.

In witness whereof, we, the said Lucian Gaulard and John Dixon Gibbs, have hereunto set our hands and seal, this twenty-third day of February, one thousand eight hundred and eighty-three.

L. GAULARD.  
J. DIXON GIBBS.

This is the specification referred to in the annexed Letters of Registration granted to Lucian Gaulard and John Dixon Gibbs, this fourth day of June, A.D. 1883.

AUGUSTUS LOFTUS.

---

**REPORT.**

---

Sir,

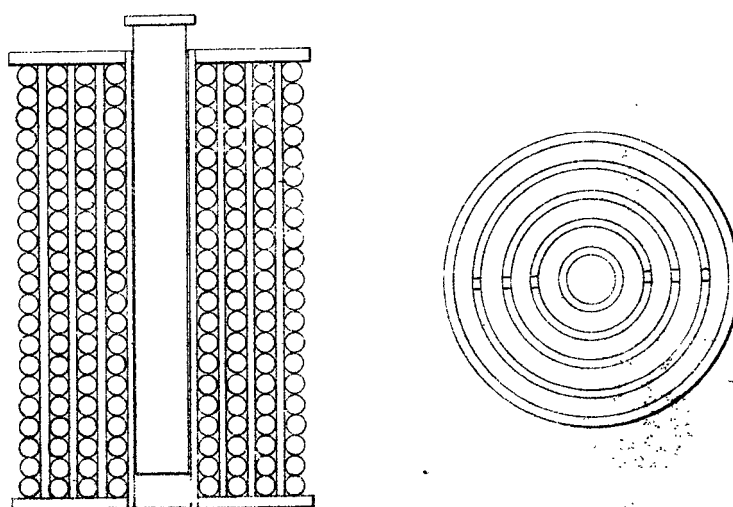
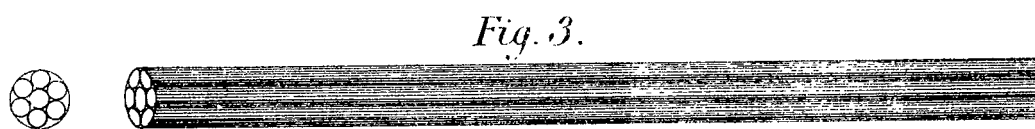
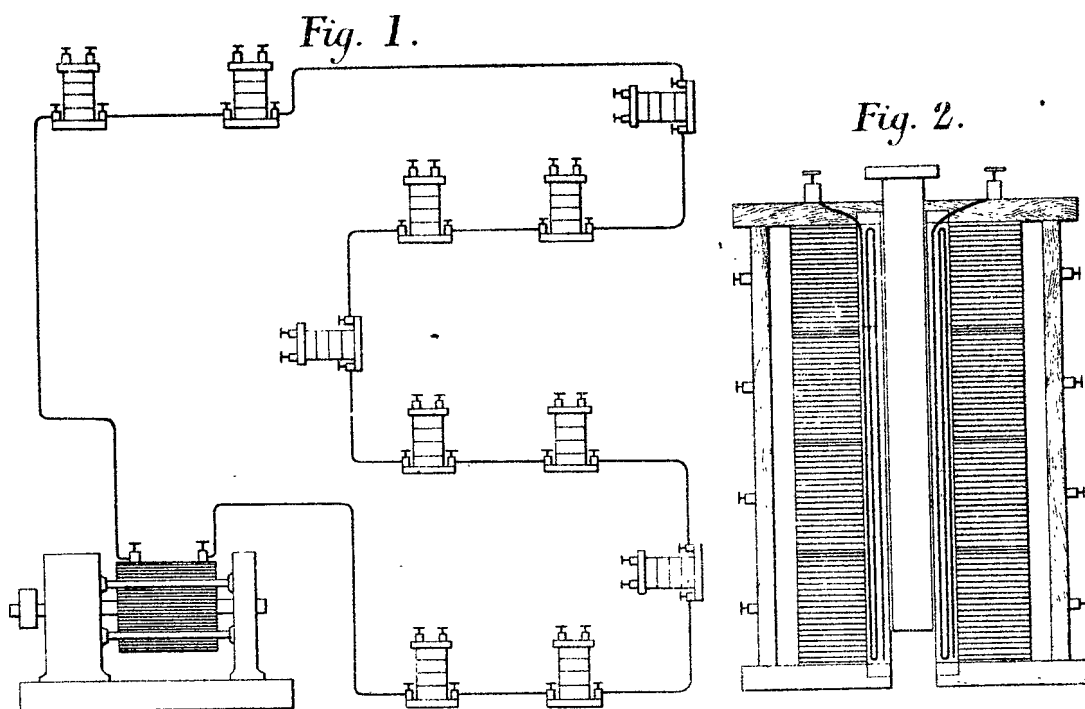
We do ourselves the honor to report, in reply to your blank cover of the 7th instant, No. 4,466, transmitting Messrs. Lucian Gaulard and John Dixon Gibbs' Petition for the registration of "A new System of Distributing Electricity for the Production of Light and Power," that we are of opinion the prayer of the Petitioners may be granted in terms of their specification, drawings, and claim.

We have, &c.,

E. C. CRACKNELL.  
GOTHER K. MANN.

The Under Secretary of Justice.

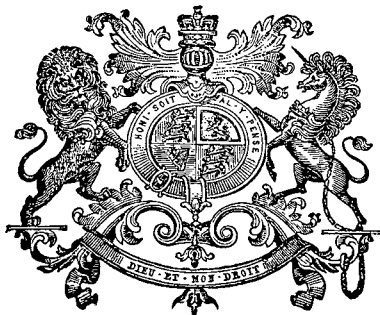
[Drawings—one sheet.]



*This is the Sheet of Drawings referred to in the annexed Letters of Registration granted to Lucian Gaulard and John Dixon Gibbs, this fourth day of June, A.D. 1883.*

*(Sig. 3.5.)*

*Augustus Loftus.*



A.D. 1883, 11th June. No. 1254.

AN IMPROVEMENT IN PERMANENT WAY.

LETTERS OF REGISTRATION to Friedrich Hoffmann, for an Improvement in Permanent Way.

[Registered on the 12th day of June, 1883, in pursuance of the Act 16 Vic. No. 24.]

BY HIS EXCELLENCY THE RIGHT HONORABLE SIR AUGUSTUS WILLIAM FREDERICK SPENCER LOFTUS (commonly called LORD AUGUSTUS LOFTUS), Knight Grand Cross of the Most Honorable Order of the Bath, a Member of Her Majesty's Most Honorable Privy Council, Governor and Commander-in-Chief of the Colony of New South Wales and its Dependencies.

TO ALL TO WHOM THESE PRESENTS SHALL COME, greeting :

WHEREAS FRIEDRICH HOFFMANN, of the city of Berlin, in the German Empire, Engineer and Architect, hath by his Petition humbly represented to me that he is the author or designer of a certain invention or improvement in manufactures, that is to say, of an invention entitled "An Improvement in Permanent Way," which is more particularly described in the amended specification marked "A," and the two sheets of drawings marked "B" and "C" respectively, which are hereunto annexed; and that he, the said Petitioner, hath deposited with the Honorable the Treasurer of the said Colony of New South Wales the sum of Twenty Pounds sterling, for defraying the expense of granting these Letters of Registration, as required by the Act of Council, sixteenth Victoria, number twenty-four; and hath humbly prayed that I would be pleased to grant Letters of Registration, whereby the exclusive enjoyment and advantage of the said invention or improvement might be secured to him for a period of fourteen years: And I, being willing to give encouragement to all inventions and improvements in the arts or manufactures which may be for the public good, and having received a report favourable to the prayer of the said Petition, from competent persons appointed by me to examine and consider the matters stated therein and to report thereon for my information, am pleased, with the advice of the Executive Council, and in exercise of the power and authority given to me by the said Act of Council, to grant, and do by these Letters of Registration grant unto the said Friedrich Hoffmann, his executors, administrators, and assigns, the exclusive enjoyment and advantage of the said invention or improvement, for and during the term of fourteen years from the date hereof; to have, hold, and exercise unto the said Friedrich Hoffman, his executors, administrators, and assigns, the exclusive enjoyment and advantage thereof for and during and unto the full end and term of fourteen years from the date of these presents next and immediately ensuing, and fully to be complete and ended: Provided always, that if the said Friedrich Hoffmann shall not, within three days after the granting of these Letters of Registration, register the same in the proper office in the Supreme Court, at Sydney, in the said Colony of New South Wales, then these Letters of Registration, and all advantages whatsoever hereby granted, shall cease and become void.

In witness whereof, I have hereunto set my sign manual, and have caused the present Letters of Registration to be sealed with the seal of the said Colony of New South Wales, at Government House, Sydney, in New South Wales, this eleventh day of June, in the year of our Lord one thousand eight hundred and eighty-three.

[L.S.]

AUGUSTUS LOFTUS.



*An Improvement in Permanent Way.*

A.

SPECIFICATION of FRIEDRICH HOFFMANN, of the City of Berlin, in the German Empire, Engineer and Architect, for an invention entitled "An Improvement in Permanent Way."

THIS invention relates to rails for permanent way. The rails are rolled in about the form of angle iron, approximately shaped to an equilateral triangle, the bottom side or base of which is left away. The rounded off apex constitutes the head of the rail, while the two sides of the angle iron are so shaped as to form clamps adapted to rest on transverse or longitudinal sleepers, or on concrete, or directly on the ballast, or, in the case of buildings, directly on the flooring.

The rails are intended for use more especially for local lines and for short lines laid down for serving ironworks, brickworks, large factories, and similar establishments and purposes.

In the drawings, figure 1 represents a rail laid in concrete. Figure 2 represents a rail laid on a transverse sleeper. Figure 3 represents a rail laid on a longitudinal sleeper. Figure 4 represents a rail laid directly on the ballast, the size of parts  $z z$  being increased so as to virtually form a longitudinal sleeper. Figure 5 represents a rail in which the feet  $x x$  are made in a separate piece  $b$ , and are rivetted to the rail as shown. Figure 6 represents a rail in which a single foot  $x$  on loose piece  $b$  is rivetted to the rail proper. Figure 7 represents the rail resting and secured in the recessed part of loose piece  $b$ , which carries a single foot  $x$  and double feet  $z z$ . Figure 8 represents a rail resting in the loose part  $b$ , which carries the feet and shoulders  $z z$ ,  $x x$ , and  $y y$ . The feet  $z z$  are made longer or shorter, or are inclined outwards more or less, according to the nature of the ground or foundation, or the kind of sleepers on which the rails are laid. The feet  $x x$  hold the rail firmly, and the two rails are maintained parallel by means of tie-rods or bars, or by the transverse sleepers where such are used; the longitudinal form of sleeper is, however, preferable. In figures 1, 2, and 3 are also shown cross-sections of a wheel suitable for using on lines of these rails, the tire of such wheels in different modifications having flanges  $w w$  on each side of the groove on which the wheel runs, the two flanges being made sufficiently wide to enable the trucks to be run on common, paved, or macadamised roads. In figures 4, 5, 6, and 7 I have shown the rail as being formed with a heavier head, and adapted for the single flange wheels now ordinarily employed for rolling stock. In figure 8 the loose part  $b$  forms a continuous longitudinal sleeper, into which the rail fits.

Having described the nature and mode of carrying out my invention, I would have it understood that I do not claim to be the inventor of the rail known to the trade as the "bridge rail" or the "Barlow rail," but I only claim—

A rail for permanent way made of angle iron, having its sides shaped so as to form clamps or feet, substantially as herein described, and as illustrated in the drawings.

In witness whereof I have hereto set my hand.

FRIEDRICH HOFFMANN,  
By his Agent,  
FRED. WALSH.

This is the amended specification marked "A," referred to in the annexed Letters of Registration granted to Friedrich Hoffmann, this eleventh day of June, A.D. 1883.

AUGUSTUS LOFTUS.

## REPORTS.

Sir,

Sydney, 10th August, 1882.

Referring to your communication of the 17th ultimo, requesting us to report on an application from Mr. Friedrich Hoffmann, for Letters of Registration for an invention entitled "Improvement in Rails for Permanent Way, and in Wheels adapted to travel on the same, said wheels being also adapted for travelling on Common Roads," we beg to inform you that we are unable to recommend the granting of such Letters, as we do not consider the invention possesses sufficient novelty.

We have, &c.,  
JAMES BARNET.  
WILLIAM C. BENNETT.

The Under Secretary of Justice.

Sir,

Sydney, 24 February, 1883.

In reply to your B.C. communication of the 19th inst., forwarding letter from Mr. Walsh on behalf of Mr. Hoffmann, accompanied by model and copies of specifications attached to German and English patents, we have to report that Mr. Walsh having called at this office and disclaimed all intention on behalf of Mr. Hoffman to secure protection for the "Barlow rail," or any modification of it, and withdrawn all claim as to improvements in wheels, we think that on the specifications and damages so modified, protection might be given to the rail with feet as proposed.

We have, &c.,  
JAMES BARNET,  
WILLIAM C. BENNETT.

The Under Secretary of Justice.

Sir,

Sydney, 18 April, 1883.

With reference to your B.C. communication of the 15th March, enclosing amended specification of Mr. Hoffman's application for Letters of Registration for an invention entitled "Improvements in Rails for Permanent Way," we are of opinion that Letters of Registration may now be granted on the amended specification and drawings accompanying the same.

We have, &c.,  
JAMES BARNET,  
WILLIAM C. BENNETT.

The Under Secretary of Justice.

Fig 1.

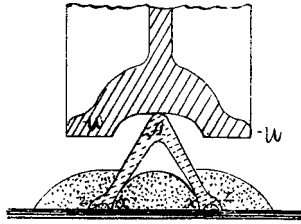


Fig 2.

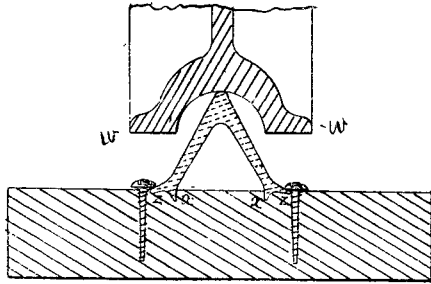
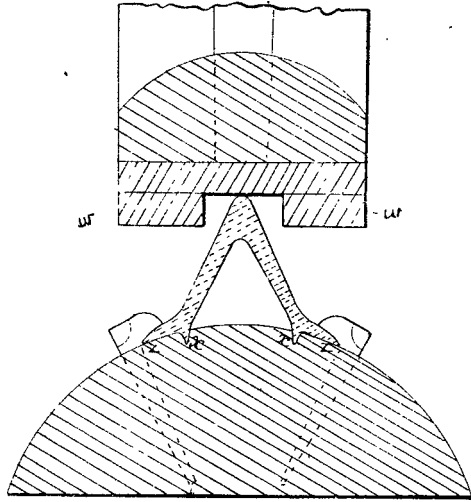


Fig 3.



Witness:  
*Helmuth Dinkberg*  
 7 Kesselstrasse, Berlin.

*Friedrich Hoffmann*

This is the Sheet of Drawings marked B referred to in the annexed  
 Letters of Registration granted to Friedrich Hoffmann, this eleventh  
 day of June A.D. 1883.

(5435-)

Augustus Loftus.

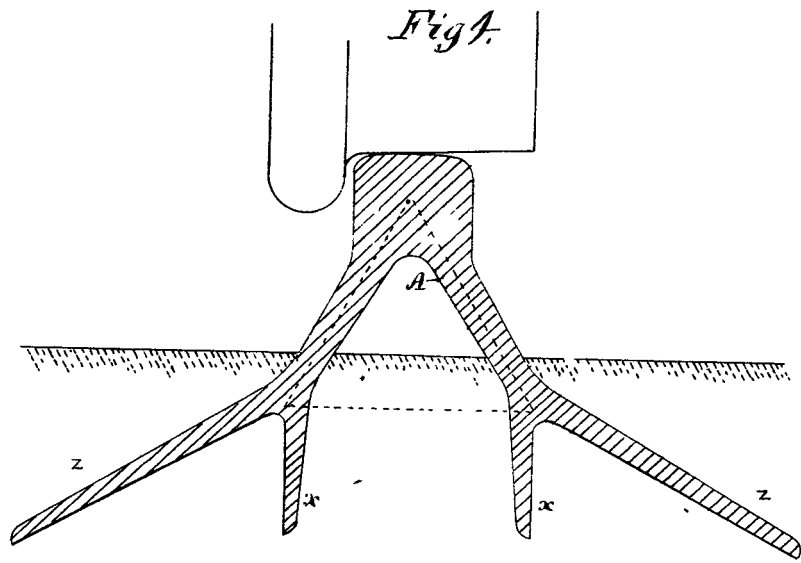


Fig. 5.

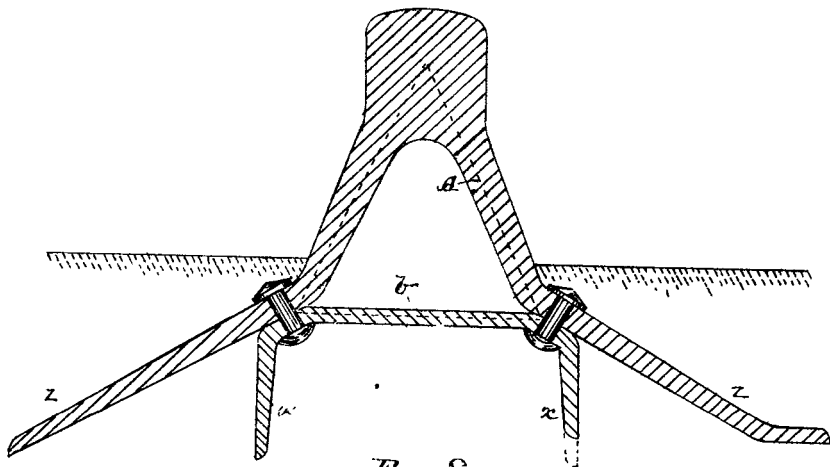


Fig. 8.

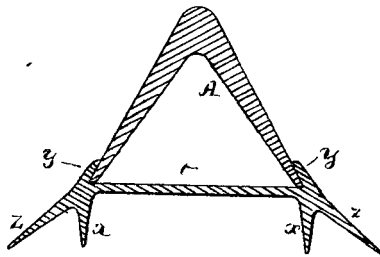


Fig. 6.

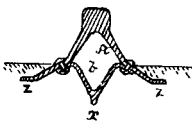
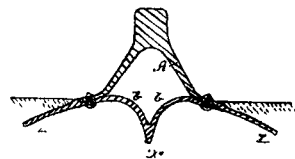


Fig. 7.



Witness:  
Helmuth Duesberg  
7 Kesselstr. Berlin.

Friedrich Hoffmann

This is the Sheet of Drawings marked C referred to in the annexed Letters of Registration granted to Friedrich Hoffmann, this eleventh day of June A.D. 1883.

(Sig 35-)

Augustus Loftus.



A.D. 1883, 12th June. No. 1255.

IMPROVEMENTS IN THE PROCESS OF FERMENTING LIQUIDS.

LETTERS OF REGISTRATION to Frederic Isenbart Scard, for Improvements in the Process of Fermenting Liquids.

[Registered on the 13th day of June, 1883, in pursuance of the Act 16 Vic. No. 24.]

BY HIS EXCELLENCY THE RIGHT HONORABLE SIR AUGUSTUS WILLIAM FREDERICK SPENCER LOFTUS (commonly called LORD AUGUSTUS LOFTUS), Knight Grand Cross of the Most Honorable Order of the Bath, a Member of Her Majesty's Most Honorable Privy Council, Governor and Commander-in-Chief of the Colony of New South Wales and its Dependencies.

TO ALL TO WHOM THESE PRESENTS SHALL COME, greeting:

WHEREAS FREDERIC ISENBART SCARD, of Demerara, British Guiana, analytical chemist, hath by his Petition humbly represented to me that he is the author or designer of a certain invention or improvement in manufactures, that is to say, of an invention entitled "Improvements in the Process of Fermenting Liquids," which is more particularly described in the specification which is herewith annexed; and that he, the said Petitioner, hath deposited with the Honorable the Treasurer of the said Colony of New South Wales the sum of Twenty Pounds sterling, for defraying the expense of granting these Letters of Registration, as required by the Act of Council, sixteenth Victoria, number twenty-four; and hath humbly prayed that I would be pleased to grant Letters of Registration, whereby the exclusive enjoyment and advantage of the said invention or improvement might be secured to him for a period of fourteen years: And I, being willing to give encouragement to all inventions and improvements in the arts or manufactures which may be for the public good, and having received a report favourable to the prayer of the said Petition, from competent persons appointed by me to examine and consider the matters stated therein and to report thereon for my information, am pleased, with the advice of the Executive Council, and in exercise of the power and authority given to me by the said Act of Council, to grant, and do by these Letters of Registration grant unto the said Frederic Isenbart Scard, his executors, administrators, and assigns, the exclusive enjoyment and advantage of the said invention or improvement, for and during the term of fourteen years from the date hereof; to have, hold, and exercise unto the said Frederic Isenbart Scard, his executors, administrators, and assigns, the exclusive enjoyment and advantage thereof, for and during and unto the full end and term of fourteen years from the date of these presents next and immediately ensuing, and fully to be complete and ended: Provided always, that if the said Frederic Isenbart Scard shall not, within three days after the granting of these Letters of Registration, register the same in the proper office in the Supreme Court, at Sydney, in the said Colony of New South Wales, then these Letters of Registration, and all advantages whatsoever hereby granted, shall cease and become void.

In witness whereof, I have hereunto set my sign manual, and have caused the present Letters of Registration to be sealed with the seal of the said Colony of New South Wales, at Government House, Sydney, in New South Wales, this twelfth day of June, in the year of our Lord one thousand eight hundred and eighty-three.

[L.S.]

AUGUSTUS LOFTUS.

*Improvements in the Process of Fermenting Liquids.*

TO ALL TO WHOM IT MAY CONCERN, Be it known that I, [FREDERIC ISENBART SCARD, of Demerara, British Guiana, analytical chemist, have invented or discovered new and useful improvements in the process of fermenting liquids, and I, the said FREDERIC ISENBART SCARD, do hereby declare the nature of the said invention, and in what manner the same is to be performed to be particularly described and ascertained in and by the following statement thereof, that is say,—

THE object of this invention is to increase the growth of yeast or other ferment in solutions which are to be fermented, or are being fermented, so as when alcoholic liquids are to be made, to increase the rapidity and completeness of the transformation of the saccharine matter into alcohol, and when yeast or other product is to be made, to increase the quantity of the said product.

I have been led to conclude that in many cases the cause of comparative slowness and incompleteness of the fermentation as at present carried on, is due to a deficiency in the wash of the nutritive material upon which the propagation and nourishment of the yeast or other ferment depends, viz., nitrogen. This deficiency of nutritive material I propose to remedy by the addition of certain inorganic chemical compounds of which the yeast possesses the power of appropriating and assimilating the nitrogen. These compounds are sulphate of ammonia, chloride of ammonia, nitrate of ammonia, tartrate of ammonia, and nitric acid. Their mode of use is as follows:—

The wash having been set up at the usual or any other suitable specific gravity one of the above salts, sulphate, chloride, nitrate, or tartrate of ammonia, or a mixture of any two or more of these is added, and thoroughly dissolved in the wash.

The quantity which I use is dependent upon the proportion of nitrogenous constituent already present and should be such as to ensure that nearly all the saccharine matter present is converted into alcohol, the proportion or proportions of the salt or salts being so arranged as to give the requisite amount of nitrogen.

The yeast feeds on and is nourished by the salt or salts of ammonia whose action is supplemental to and more rapid than that of the nitrogenous matter before mentioned as present in most fermentable liquids, and the result is an increased production of healthy yeast or ferment. This yeast or ferment causes a more rapid attenuation of the wash or wort, and a larger production of alcohol.

In the fermentation of molasses, for instance, as at present carried out, a considerable quantity of the saccharine matter escapes fermentation and is consequently lost. The fermentation also extends over a considerable period of time, often amounting to seven or eight days, great inconvenience thus arising, and opportunity being afforded for fermentative action other than alcoholic occurring.

The quantity to be added in the case of molasses ought to contain so much nitrogen as would give 2lb. of nitrogen to 1,000 gallons of wash, and this amount would be approximately yielded by the following weights of the respective compounds, viz.:—

Sulphate of ammonia	...	...	...	...	...	10lb. av.
Chloride of ammonia	...	...	...	...	...	7½ "
Nitrate of ammonia	...	...	...	...	...	5½ "
Tartrate of ammonia	...	...	...	...	...	13 "

Should a mixture of these salts be used the proportions can be so arranged as to give the requisite amount of nitrogen. Where sulphuric acid is used in the wash to create an acid condition a portion of the acidity requisite can be added in the form of nitric acid. Two-thirds of a gallon of nitric acid is to be used per 1,000 gallons of wash, about 2lb. of nitrogen being thus added. This is equivalent to about 3½ pints of oil of vitriol, and if further acidity is required it can be added in the form of sulphuric acid. Where nitric acid is used there is no occasion to use the ammoniacal compounds.

Having thus described the nature of my invention and the manner of performing the same, I declare that what I claim as my invention is—

First—The application and employment of certain inorganic salts of ammonia by their addition to a fermentable liquid in order to promote the growth of the yeast or ferment as and for the purpose specified.

Second—The application and employment of nitric acid by its addition to a fermentable liquid in complete or partial substitution for another acid, in order to promote the growth of the yeast or ferment as and for the purpose specified.

The above specification of my invention, signed by me this fifth day of March, A.D. 1883.

FREDERIC I. SCARD, F.C.S.

This is the specification referred to in the annexed Letters of Registration granted to Frederic Isenbart Scard, this 12th day of June, A.D. 1883.

AUGUSTUS LOFTUS.

---

REPORT.

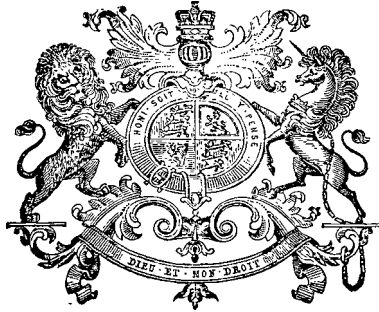
Sir,

In the matter of the application of Mr. Frederic Isenbart Scard for Letters of Registration for "Improvements in the Process of Fermenting Liquids," which has been referred to us, we have examined the specification accompanying the same, and have the honor to report that we see no objection to the issue of Letters of Registration as prayed for.

Sydney, 27 April, 1883.

We have, &c.,  
CHAS. WATT.  
A. LEIBIUS.

The Under Secretary of Justice.



A.D. 1883, 12th June. No. 1256.

IMPROVEMENTS IN MACHINES FOR EXCAVATING AND REMOVING EARTH.

LETTERS OF REGISTRATION to George Westle, for Improvements in Machines for Excavating and Removing Earth.

[Registered on the 13th day of June, 1883, in pursuance of the Act 16 Vic. No. 24.]

BY HIS EXCELLENCY THE RIGHT HONORABLE SIR AUGUSTUS WILLIAM FREDERICK SPENCER LOFTUS (commonly called LORD AUGUSTUS LOFTUS), Knight Grand Cross of the Most Honorable Order of the Bath, a Member of Her Majesty's Most Honorable Privy Council, Governor and Commander-in-Chief of the Colony of New South Wales and its Dependencies.

TO ALL TO WHOM THESE PRESENTS SHALL COME, greeting :

WHEREAS GEORGE WESTLE, of Coree Station, near Deniliquin, in the Colony of New South Wales, blacksmith, hath by his Petition humbly represented to me that he is the author or designer of a certain invention or improvement in manufactures, that is to say, of an invention entitled "Improvements in Machines for Excavating and Removing Earth," which is more particularly described in the specification and the sheet of drawings which are hereunto annexed; and that he, the said Petitioner, hath deposited with the Honorable the Treasurer of the said Colony of New South Wales the sum of Twenty Pounds sterling, for defraying the expense of granting these Letters of Registration, as required by the Act of Council, sixteenth Victoria, number twenty-four, and hath humbly prayed that I would be pleased to grant Letters of Registration, whereby the exclusive enjoyment and advantage of the said invention or improvement might be secured to him for a period of fourteen years: And I, being willing to give encouragement to all inventions and improvements in the arts or manufactures which may be for the public good, and having received a report favourable to the prayer of the said Petition, from competent persons appointed by me to examine and consider the matters stated therein and to report thereon for my information, am pleased, with the advice of the Executive Council, and in exercise of the power and authority given to me by the said Act of Council, to grant, and do by these Letters of Registration grant unto the said George Westle, his executors, administrators, and assigns, the exclusive enjoyment and advantage of the said invention or improvement, for and during the term of fourteen years from the date hereof; to have, hold, and exercise unto the said George Westle, his executors, administrators, and assigns, the exclusive enjoyment and advantage thereof, for and during and unto the full end and term of fourteen years from the date of these presents next and immediately ensuing, and fully to be complete and ended: Provided always, that if the said George Westle shall not, within three days after the granting of these Letters of Registration, register the same in the proper office in the Supreme Court, at Sydney, in the said Colony of New South Wales, then these Letters of Registration, and all advantages whatsoever hereby granted, shall cease and become void.

In witness whereof, I have hereunto set my sign manual, and have caused the present Letters of Registration to be sealed with the seal of the said Colony of New South Wales, at Government House, Sydney, in New South Wales, this twelfth day of June, in the year of our Lord one thousand eight hundred and eighty-three.

[L.S.]

AUGUSTUS LOFTUS.

*Improvements in Machines for Excavating and Removing Earth.*

SPECIFICATION of GEORGE WESTLE, of Coree Station, near Deniliquin, in the Colony of New South Wales, blacksmith, for an invention entitled "Improvements in Machines for Excavating and Removing Earth."

THIS invention consists of certain improvements in machines for excavating and removing earth, by which they can be economically constructed, and may be efficiently and readily worked with one man.

Machines made according to my invention have an excavator or scoop, which can be readily lowered to the required position for excavating; when filled can be readily raised again to the required height for removal; and when at the place of discharge can be as readily emptied and returned again to their previous position for transport to the place of excavation to commence work anew.

Referring to my drawings, figure 1 shows side elevation of one of my machines; figure 2, plan; and figure 3, back view of same. A is the excavator or scoop proper, swivelling on gudgeons at A<sup>1</sup> in framing A<sup>2</sup>. A<sup>3</sup> is its back, which always remains in the same position relatively to the framing A<sup>2</sup>. A<sup>4</sup> is its front, which swivels on spindle A<sup>5</sup>, resting in bearings, A<sup>6</sup>, in the end of the framing A<sup>2</sup>. This front is connected to said spindle by metal straps, A<sup>7</sup>, and is otherwise supported by triangular framing A<sup>8</sup>, on which are screw-links, A<sup>9</sup>, for adjustment. Said spindle A<sup>5</sup> is also connected by short arms, A<sup>10</sup>, to another triangular framing, A<sup>11</sup>, which works freely in bearing, B<sup>1</sup>, attached to the centre beam, B, of the machine by stays B<sup>1</sup> and B<sup>2</sup>. To the triangular base of framing A<sup>8</sup> is attached a chain or cord, A<sup>12</sup>, which is connected to eye on stay B<sup>1</sup> to maintain the horizontal position of front door A<sup>4</sup>, when scoop A is in its cutting position, as shown. At either side of the scoop, and at its hinder part, is a catch, D, kept in position by flat springs D<sup>1</sup>, and released by means of lever D<sup>2</sup> through the intervention of rods and links D<sup>3</sup>. Across the front portion of the excavator is a spindle, E, to which is attached hand-lever E<sup>1</sup> for tipping the scoop to discharge. In order to preserve the level of the scoop when thrown out of level by reason of one wheel running on higher ground than the other, I provide a spindle, F, having its bearings in side framing G, and carrying two eccentrics F<sup>1</sup> grooved on their periphery. In these grooves fit metal loops, F<sup>2</sup>, connected at the bottom to the hinder end of scoop framing A<sup>2</sup>. On spindle F is arm F<sup>3</sup>, to which is attached hand-lever F<sup>4</sup>, the upper end of which works in slotted guide F<sup>5</sup>, and has a guide-pin at its side. H is the axle of the draught wheels, from whence all the power is derived. H<sup>1</sup>H<sup>1</sup> are the draught wheels. H<sup>2</sup> spur pinion, which is secured to wheels by bolts through nave at H<sup>2</sup>. J is a counter shaft, to which motion is imparted from spur pinion H<sup>2</sup> through toothed wheel, J<sup>1</sup>, when it is in gear with it. It is in gear with it when the scoop is being lifted, but not at any other time. It is moved in and out of gear by means of cranked hand-lever J<sup>2</sup> (through which shaft J passes and works itself on shaft F) and catch J<sup>3</sup>, the latter of which fits into the teeth of rack J<sup>4</sup> and preserves the lever J<sup>2</sup> in the position to which it is moved. When in gear, the shaft J revolves, and with it the grooved pulleys J<sup>5</sup> and J<sup>6</sup>. Those marked J<sup>5</sup> are connected by ropes or chains, J<sup>7</sup>, with the hinder end of the scoop framing A<sup>2</sup>, while that one marked J<sup>6</sup> is connected by chain or rope J<sup>8</sup> (passing over pulley B<sup>3</sup>) with the triangular base of the front scoop framing, and so are raised and lowered simultaneously by the backward and forward revolution of shaft J. J<sup>9</sup> is a check-chain. In order to prevent the forward revolution of shaft J when lifting the scoop, I provide a lever pawl K and ratchet K<sup>1</sup>, the latter keyed on said shaft J. This shaft J rests in bearings in side-framing G, but the bearings of that end of this shaft which carries the toothed wheel rack and pinion, &c., is slotted at G<sup>1</sup> and G<sup>2</sup> to allow of the raising and lowering of said shaft when said toothed wheel is required to be put in or out of gear with the spur pinion H<sup>2</sup>. The centre beam B rests in front on forked bearings L for the front wheel L<sup>1</sup>. To this forked bearing is attached the forked butt M of the pole M<sup>1</sup>, to which are attached swingle-trees M<sup>2</sup>.

The mode of operation is as follows:—When about to commence excavating, the scoop is lowered ready for scooping as shown in the drawings. The toothed wheel J<sup>1</sup> must then be released from spur pinion H<sup>2</sup>. This is effected by compressing the handle of catch J<sup>3</sup> towards hand-lever J<sup>2</sup>, and by means of said hand-lever lifting shaft J and so raising toothed wheel J<sup>1</sup> out of gear with pinion H<sup>2</sup>, and preserving that position by allowing catch J<sup>3</sup> to fall between two of the teeth of rack J<sup>4</sup>. The onward movement of the machine then fills the scoop. When it is full I withdraw catch J<sup>3</sup> from its rack J<sup>4</sup>, and, by means of hand-lever J<sup>2</sup>, lower the shaft J, so that toothed wheel J<sup>1</sup> again falls into gear with spur pinion H<sup>2</sup>. The onward movement of the machine then revolves shaft J, and with it the grooved pulleys J<sup>5</sup> and J<sup>6</sup> which wind up ropes or chains J<sup>7</sup> and J<sup>8</sup>, and so raise both back and front of scoop and close the front A<sup>4</sup> at same time. When raised to the required height, the toothed wheel J<sup>1</sup> must again be lifted out of gear from the spur pinion H<sup>2</sup>, the lever pawl K and ratchet K<sup>1</sup> preserving the position and preventing the unwinding of the ropes or chains which have lifted the scoop. The machine can now be driven to the point of discharge when the side-catches D must be released by means of hand-lever D<sup>2</sup>. If the scoop does not now tip backwards of itself, the driver takes hold of the hand-lever E<sup>1</sup>, and, pulling it towards him, gives the scoop a sufficient cant to compel it to tip, and if it does not readily discharge all its contents, he can give it a shake by the same means and then return it to its previous position. The side-catches D are then replaced and the machine driven to the place of excavation. The lever pawl K is then released from its ratchet K<sup>1</sup> and the scoop will fall by its own weight, unwinding the ropes or chains J<sup>7</sup> and J<sup>8</sup>, the front door A<sup>4</sup> opening again by the descent of the scoop. The same operation is then repeated.

In the event of the machine having to work with one wheel higher than the other, as, for instance, with one wheel on the ploughed ground and the other on the scooped ground, the level of the scoop can be adjusted by means of the grooved eccentrics F<sup>1</sup>, acted upon by means of hand-lever F<sup>4</sup>.

The check-chain J<sup>9</sup> determines the maximum depth to which the scoop may be lowered.

The metal loops F<sup>2</sup> are adjustable by means of the nuts on the tops of each.

Having thus described the nature of my invention and the manner of performing same, I would have it understood that what I believe to be new, and therefore claim as my improvements in machines for excavating and removing earth is,—

First—The combination and arrangement of parts marked J to J<sup>8</sup> inclusive, H<sup>2</sup> K and K<sup>1</sup>, by which I am enabled to raise and lower the scoop as required.

Second—the combination and arrangement with such parts of front gate or door, A<sup>4</sup>, constructed and arranged in the manner shown in my drawings so as to automatically open when the scoop is lowered and automatically close when the scoop is raised.

Third

*Improvements in Machines for Excavating and Removing Earth.*

Third—The combination with earth scoops of eccentrics F<sup>1</sup> and metal loops F<sup>2</sup> arranged and combined with the other parts of machine, substantially as described for the purpose of adjusting the level of such scoops.

Fourth—The combination and arrangement of the lever, D<sup>2</sup>, rods and links, D<sup>3</sup>, for the purpose of releasing spring catches D<sup>1</sup> when required, substantially as herein described and explained.

In witness whereof, I, the said George Westle, have hereto set my hand and seal this  
day of \_\_\_\_\_, one thousand eight hundred and eighty-three.

GEORGE WESTLE.

Witness—THOMAS STONE, tank sinker and blacksmith, Thuarra Station, Marra Creek, care of  
J. Patrick, Esq., New South Wales.

This is the specification referred to in the annexed Letters of Registration granted to George Westle, this twelfth day of June, A.D. 1883.

AUGUSTUS LOFTUS.

---

REPORT.

Sir,

Sydney, 7 May, 1883.

With reference to your B.C. minute of the 3rd March, forwarding Petition of Mr. George Westle for Letters of Registration for an invention entitled "Improvements in Machines for excavating and removing earth," we are of opinion that such letters might be issued.

We have, &c.,

JAMES BARNET.

WILLIAM C. BENNETT.

The Under Secretary of Justice.

---

[Drawings—one sheet.]



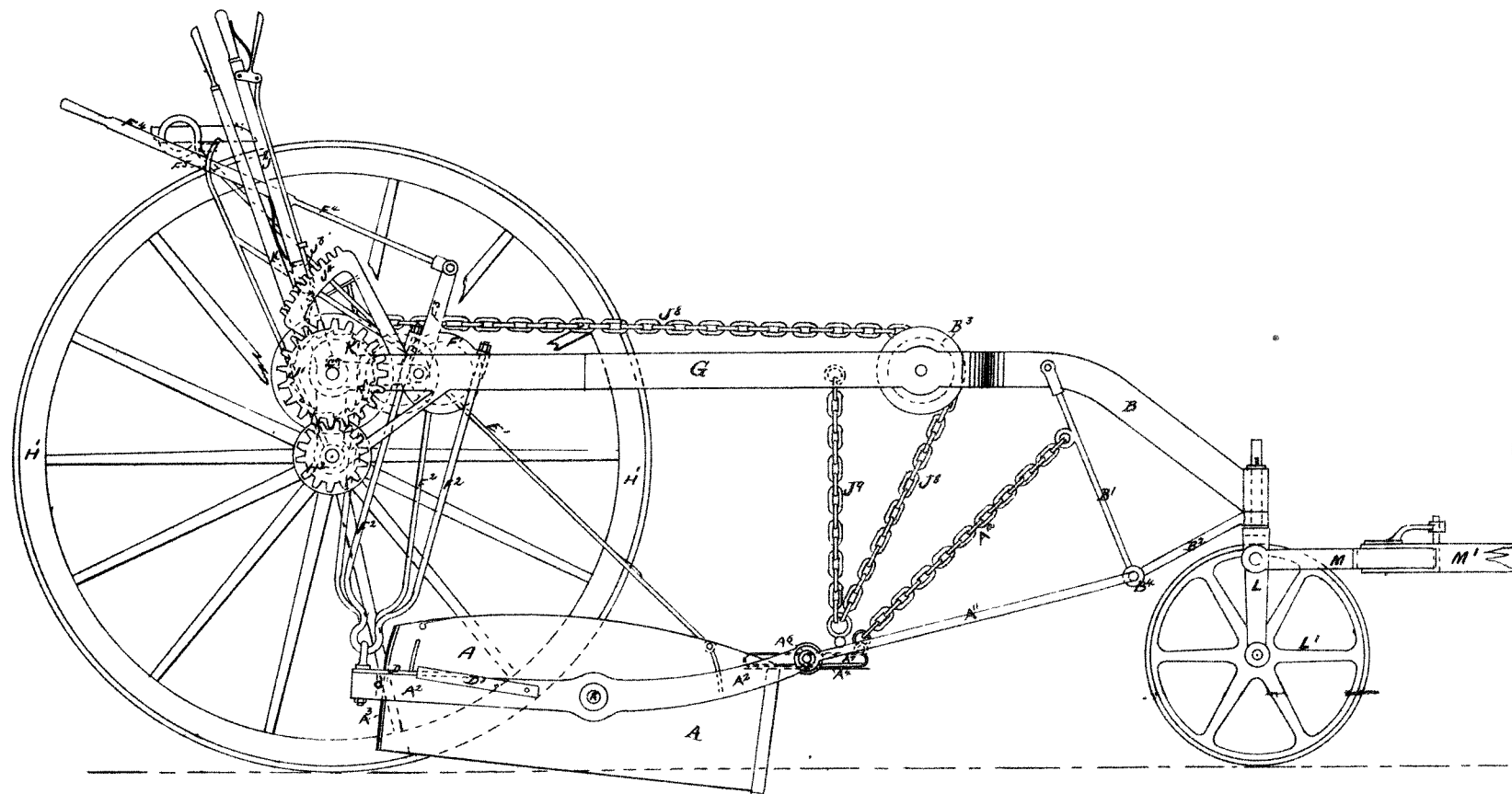


Fig. 1.

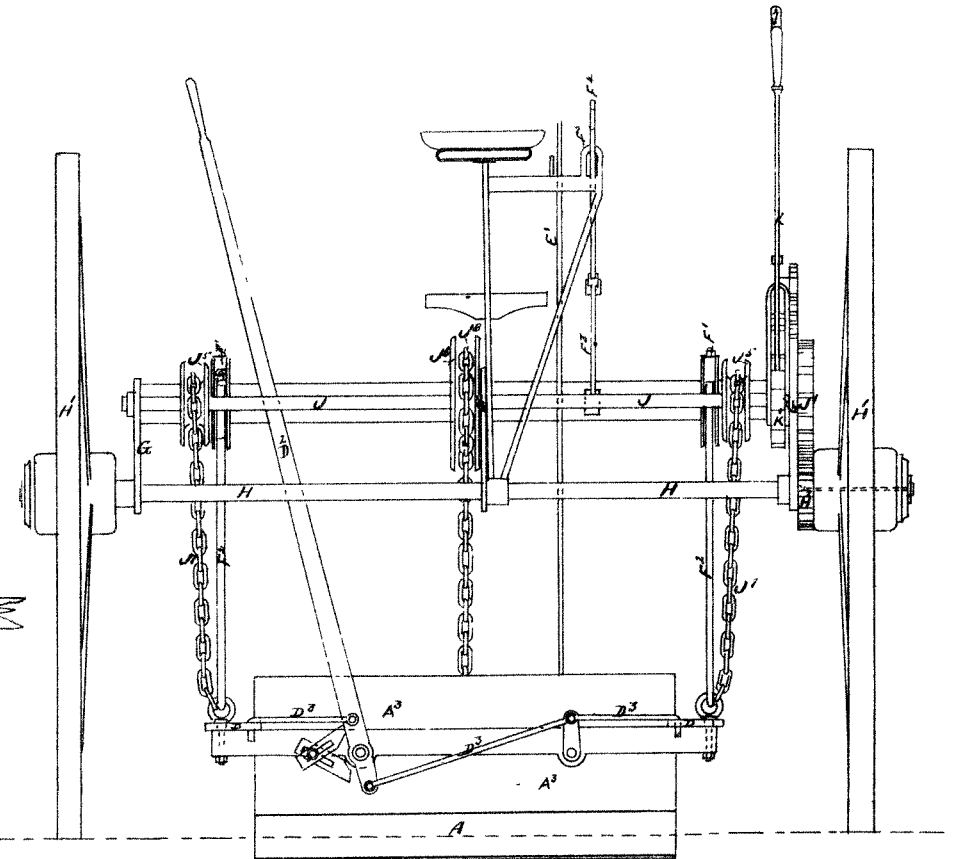


Fig. 3.

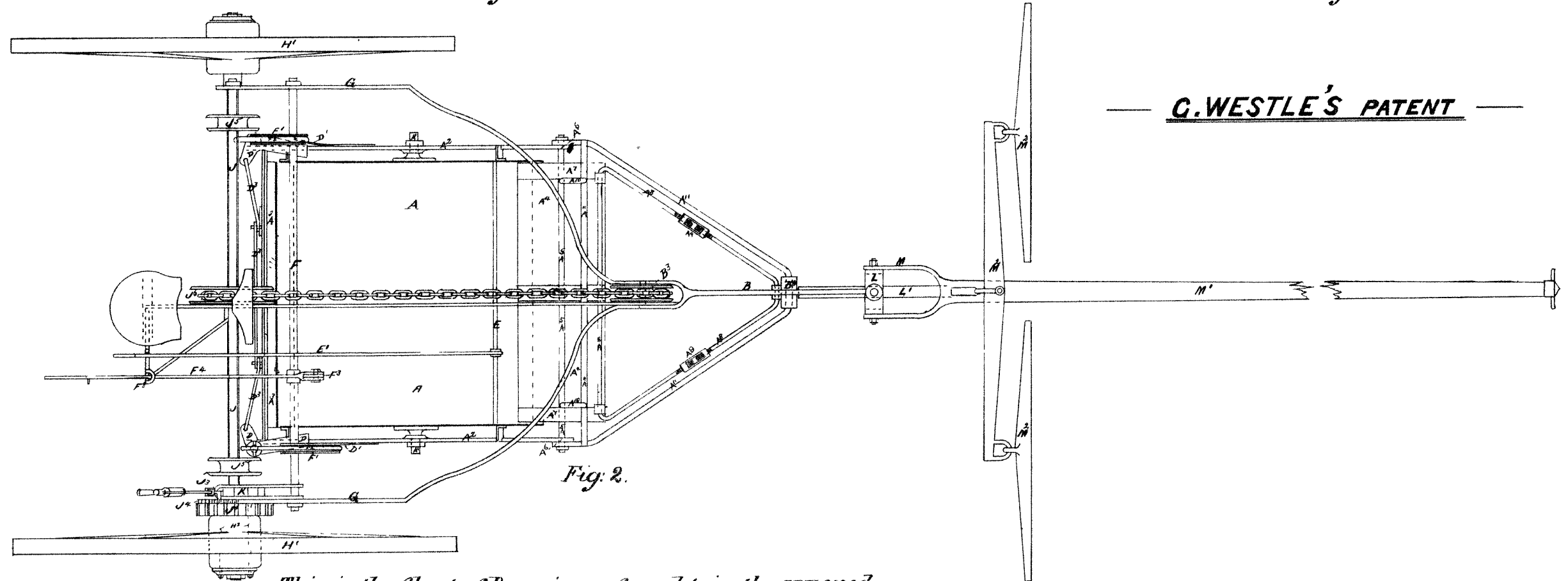


Fig. 2.

**C. WESTLE'S PATENT**

*This is the Sheet of Drawings referred to in the annexed  
 Letters of Registration granted to George Westle this 12<sup>th</sup>  
 day of June A. D. 1883.*

*Augustus Loftus*



A.D. 1883, 12th June. No. 1257.

IMPROVEMENTS IN HYDRAULIC ELEVATORS.

LETTERS OF REGISTRATION to the Hydraulic Elevator Company, for an Invention entitled Improvements in Hydraulic Elevators.

[Registered on the 13th day of June, 1883, in pursuance of the Act 16 Vic. No. 24.]

BY HIS EXCELLENCY THE RIGHT HONORABLE SIR AUGUSTUS WILLIAM FREDERICK SPENCER LOFTUS (commonly called LORD AUGUSTUS LOFTUS), Knight Grand Cross of the Most Honorable Order of the Bath, a Member of Her Majesty's Most Honorable Privy Council, Governor and Commander-in-Chief of the Colony of New South Wales and its Dependencies.

TO ALL TO WHOM THESE PRESENTS SHALL COME, greeting:

WHEREAS THE HYDRAULIC ELEVATOR COMPANY, of Chicago, Illinois, United States of America, hath by its Petition humbly represented to me that it is the assignee of Cyrus W. Baldwin, of Chicago aforesaid, who is the author or designer of a certain invention or improvement in manufactures, that is to say, of an invention entitled "Improvements in Hydraulic Elevators," which is more particularly described in the specification and the sheet of drawings which are hereunto annexed; and that the said Company hath deposited with the Honorable the Treasurer of the said Colony of New South Wales the sum of Twenty Pounds sterling, for defraying the expense of granting these Letters of Registration, as required by the Act of Council, sixteenth Victoria, number twenty-four; and hath humbly prayed that I would be pleased to grant Letters of Registration, whereby the exclusive enjoyment and advantage of the said invention or improvement might be secured to it for a period of fourteen years: And I, being willing to give encouragement to all inventions and improvements in the arts or manufactures which may be for the public good, and having received a report favourable to the prayer of the said Petition, from competent persons appointed by me to examine and consider the matters stated therein and to report thereon for my information, am pleased, with the advice of the Executive Council, and in exercise of the power and authority given to me by the said Act of Council, to grant, and do by these Letters of Registration grant unto the said Hydraulic Elevator Company, its successors, and assigns, the exclusive enjoyment and advantage of the said invention or improvement, for and during the term of fourteen years from the date hereof; to have, hold, and exercise unto the said Hydraulic Elevator Company, its successors, and assigns, the exclusive enjoyment and advantage thereof, for and during and unto the full end and term of fourteen years from the date of these presents next and immediately ensuing, and fully to be complete and ended: Provided always, that if the said Hydraulic Elevator Company shall not, within three days after the granting of these Letters of Registration, register the same in the proper office in the Supreme Court, at Sydney, in the said Colony of New South Wales, then these Letters of Registration, and all advantages whatsoever hereby granted, shall cease and become void.

In witness whereof, I have hereunto set my sign manual, and have caused the present Letters of Registration to be sealed with the seal of the said Colony of New South Wales, at Government House, Sydney, in New South Wales, this twelfth day of June, in the year of our Lord one thousand eight hundred and eighty-three.

[L.S.]

AUGUSTUS LOFTUS.

*Improvements in Hydraulic Elevators.*

SPECIFICATION of CYRUS W. BALDWIN, of Chicago, in the County of Cook, and State of Illinois, in the United States of America, for an invention entitled "Improvements in Hydraulic Elevators."

My invention relates to improvements in hydraulic elevators, and I would here state that the principles of operation involved therein have been described in the letters patent of the United States granted to me under date of April 20, 1875, No. 162262, and in the reissues of said letters patent No. 7019, of March 28, 1876, and No. 10224, of October 31, 1882, upon which latter reissued letters patents this application is based. So far as the principles involved in the operation of the apparatus are concerned, the apparatus itself being new to the best of my knowledge and belief, with the exception of minor features shown and described in letters patent of the United States, granted to me under date of April 2, 1878, No. 201980, and for which construction I have filed an application of the United States now pending.

My said invention consists in certain improvements in elevators whereby the cage may be caused to rise and descend with a regular steady motion by the expenditure of comparatively a small amount of power, be readily regulated according to the load, whereby sudden shock and straining of the parts are avoided, and whereby the requisite operations are effected through the medium of devices of a simple and inexpensive character. In the drawing—

Figure 1 is a longitudinal elevation of the improved hydraulic elevator. Figure 2 an elevation partly in section illustrating a modification, the same pump being shown connected to both appliances. Figure 3 is an enlarged section of the valve device.

The apparatus illustrated in figure 1 is intended to operate under the normal pressure of the atmosphere, or under an increased elastic pressure if desired, while that shown in figure 2 operates under the direct action of a pump, the main features of the structure being the same in both cases. A is the elevator cylinder, closed at each end, preferably arranged vertically, although it may sometimes be horizontal, and containing a piston, I, the rod, E, of which is connected in any suitable manner with the flexible cables or suspensories by which the cage, H, is suspended. At the opposite ends of the cylinder are ports communicating respectively with pipes F, E, which lead to a valve-case, C, and within the latter slides a valve, D, consisting of a spindle *p*, carrying three disks 1, 2, 3, arranged substantially as shown, the upper end of the spindle having teeth to gear with a pinion, *g*, upon the shaft of a wheel, *s*, a hand rope, *h*, passes round the wheel *s*, round the pulleys at the top and the bottom of the well and through or adjacent to the cage, so that the operator therein may at any time move said rope to raise or lower the valve.

With the pipe E, or in some cases with the valve-chest C, at a point in communication with the pipe E communicates a pipe E', leading to a reservoir K, and from the valve-chest C a discharge pipe, G, leads to a tank, L.

A pump, M, serves to draw the water from the tank L and discharge into the reservoir K, which may be arranged at such a height that the pressure of the column of water upon the piston will, when the discharge is open, depress said piston and elevate the cage and its load.

The pipes E, F, communicate with ports *x*, *y*, in the valve-case, and the disks 1, 2, 3, are so arranged that when the valve is in the position shown in figure 3, the passage of water from beneath the piston I is prevented by the closing of the port *y*, and the cage is held at rest.

When the valve is raised to bring the disk 3 just above the lower edge of the port *y*, the water from below the piston will discharge into the tank L, and the piston will descend. This movement of the piston is due not only to the weight of the column of water, which is between it and the reservoir, but also to the downward pull which is exerted on it from the water below, for in effect at the moment the discharge begins, there is as it were, resulting from air-pressure, a column of water equal in height to the length of the cylinder (usually 30 feet) which column hangs to the underside of the piston, and which, with the water above the piston, constitutes the load or working power of the latter. As this column should be as long as practicable, the discharge port should be as far as possible from the limit of the upward movement of the piston I.

The length of the column below the piston of course decreases as the piston descends, but the loss is compensated for by the lengthening of the column above the piston so that the working pressure is practically constant. By raising the valve more or less the port *y* is opened more or less and the speed of the cage thereby graduated at the will of the operator.

When the cage is to descend the valve is moved downward until the ports *x* and *y* are both put in communication with the space between the disks 1 and 2, as shown in figure 2, when the weight of the cage will draw the piston upward, the water circulating freely from the space above the piston through the pipe E, valve, and pipe F to the space below the piston. As the circulating column of water is in communication with the reservoir through the pipe E, such additional supply of water as is required for the space below the piston, in consequence of the absence of a piston-rod on this side of the piston, is supplied. By this arrangement no power is consumed in lowering the cage, while the circulating water acts as a partial brake to secure a very steady and even movement.

The speed in descending is regulated by opening the port *y* more or less, and any sudden shock in stopping may be prevented by putting a relief valve, *b*, in a channel, *f*, connecting the pipes E and F substantially as shown.

It will be seen that by a single movement, easily effected from the cage, the valve D may be set to close the discharge port and arrest the cage, or to open the discharge and cause the cage to ascend, or to put the circulating pipes into communication and permit the descent of the cage. The water discharged from the cylinder is elevated to the reservoir by the pump as fast as it flows into the tank, so that after a supply of water is once secured no further addition is needed than will compensate for evaporation. Where it is not convenient to place a reservoir in an elevated position, so as to secure the effect of the usual pressure of the atmosphere, the tank may be arranged at a lower point and made air-tight, so that upon pumping the water therein the air will be compressed to secure a pressure that will compensate for the change of position, such pressure being maintained by pumping the water into the tank at about the same speed as it flows therefrom.

The descent of the piston may be facilitated by using a closed tank L, as shown in figure 2, and by exhausting the tank under the action of the pump so as to create a partial vacuum insuring a more ready discharge from the pipe G. Relief valves *u* and *v* prevent injury to the tank from excessive ternal or internal pressure.

When

*Improvements in Hydraulic Elevators.*

When it is not desired to operate under air-pressure the cylinder, the valve, the pipes, the tank, and pump, as before described, may be arranged as shown in figure 2, the pipe N leading from the pump instead of extending to a reservoir, as in figure 1, being connected with the pipe E, or with the cylinder near the top or otherwise, so that the water withdrawn from the tank by the pump is pumped directly into the cylinder to move the piston and raise the load. In such case the load descends by circulating the water as before, and the valve D operates in like manner as before described. To avoid the shocks that might result from transmitting the pulsations of the pump to the piston, an air-vessel, P, is put in communication either with the cylinder or circulating pipe, or water-pipe, so that the elastic body of air within will absorb such pulsations.

In the device shown in figure 2, steam should be admitted to work the pump at the time that the discharge port is open, a rope, T, is therefore extended through the cage and connected to a lever, *g*, of the steam-cock, *f*, of the pump. Or this cock may be opened automatically by means of the piston or diaphragm *i* in a case, Q, communicating with the discharge pipe of the pump, which diaphragm is connected to the cock lever so that when the pressure in the discharge pipe decreases the cock will be open to start the pump, while the closing of the discharge port *g* causing an increase of pressure in the pipe N will raise the diaphragm, close the cock, and stop the pump.

It will be apparent that a valve device, differing in its construction from the valve D shown and described, may be used to secure the same result, and that other variations may be made in the structure and arrangement of parts without departing from the principle of the invention. I claim—

First—The combination in an elevator of a lifting piston cylinder closed at the ends, and pipes and valve appliances arranged to discharge the water from one end of the cylinder as the water under pressure flows into the other end to lift the cage and also to circulate the water without discharging as the cage descends, substantially as set forth.

Second—The combination in a hydraulic elevator of a lifting cylinder closed at the ends and communicating with a reservoir of water under air-pressure, a cage connected to the piston, a valve device constructed to discharge the water from one side of the piston, and also to permit the water to circulate, and appliances whereby said valve may be operated from the cage while the latter is in any position, substantially as set forth.

Third—The combination with the cylinder of a hydraulic elevator closed at the ends of a valve device and operating appliances constructed to open the discharge and to close the discharge and permit the water to circulate from one side to the other of the piston, and to arrest both the discharge and circulation, each by a single movement of the valve device, substantially as set forth.

Fourth—The combination in a hydraulic elevator of a motor-cylinder, containing a piston and closed at the ends, an inlet to supply water under air-pressure, an outlet or discharge passage below the piston, and a valve device whereby the column of water above and below the piston is caused to load and move the latter with a uniform power.

Fifth—The combination in a hydraulic elevator of a motor-cylinder closed at the ends and containing a piston attached to the cage, an inlet passage to supply water under pressure above the piston, an outlet or discharge passage below the piston, and a valve device whereby the power of the column of water above the piston and of the column of water below the piston may be jointly and simultaneously exerted to load or carry down the piston with a uniform power.

Sixth—The combination of the cylinder and pipes and passages communicating with opposite ends thereof, of a valve casing communicating with said pipes and with the discharge pipe, and containing a valve provided with three disks arranged to operate, substantially as set forth.

Seventh—The combination with the cylinder and its discharge pipe of a closed receiving tank communicating with said pipe, and an exhaust pump communicating with said tank, substantially as set forth.

Eighth—The combination with the cylinder having a piston connected with the elevator cage of a pump and passage, whereby the water may be pumped directly against the piston and a casing P containing an air-chamber, substantially as specified.

Ninth—The combination with the cylinder and pump, and passage connecting the same, of a casing communicating with the said passage and provided with a diaphragm or piston connected to operate the cock of the pump, substantially as set forth.

In witness whereof, I, the said Cyrus W. Baldwin, have hereunto set my hand and seal, this third day of February, A.D. 1883.

CYRUS W. BALDWIN.

Signed and sealed in the presence of—

W. R. HOARE, British Vice-Consul, New York.

This is the specification referred to in the annexed Letters of Registration granted to the Hydraulic Elevator Company, this twelfth day of June, A.D. 1883.

AUGUSTUS LOFTUS.

### REPORT.

Sir,

Sydney, 28 April, 1883.

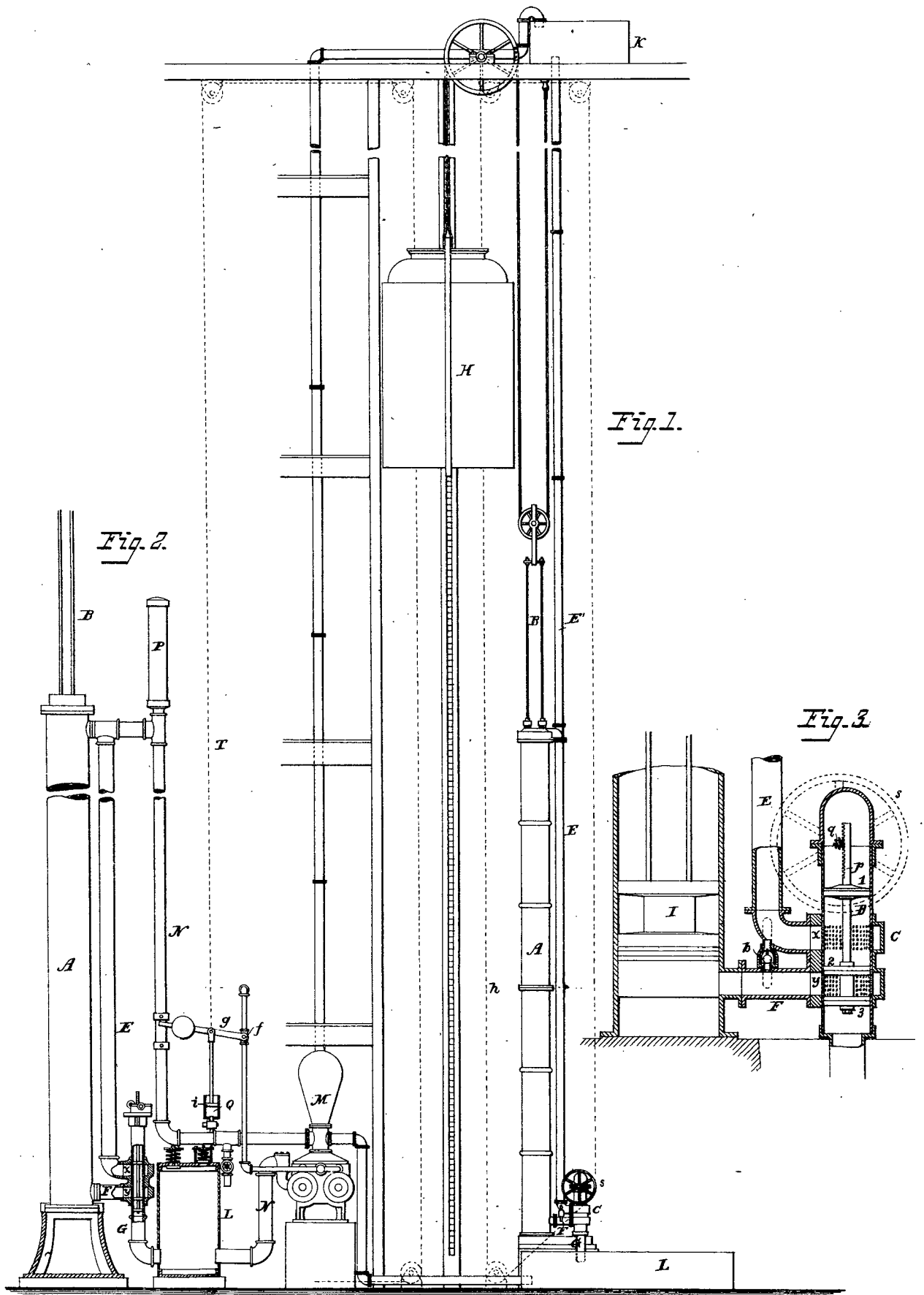
In accordance with your B.C. minute of the 14th instant, on the application of the Hydraulic Elevator Company for Letters of Registration for an invention entitled "Improvements in Hydraulic Elevators," we have to report that we see no reason why the request should not be complied with.

We have, &c.,

JAMES BARNET.

WILLIAM C. BENNETT.

The Under Secretary of Justice.



*This is the Sheet of Drawings referred to in the annexed  
 Letters of Registration granted to the Hydraulic Elevator  
 Company this 12<sup>th</sup> day of June A. D. 1883*

*(Sig. 35.)*

*Augustus Loftus*

PHOTO-LITHOGRAPHED AT THE GOVT. PRINTING OFFICE,  
 SYDNEY, NEW SOUTH WALES.



A.D. 1883, 12th June. No. 1258.

AN IMPROVED CLOTHES-WASHING MACHINE.

LETTERS OF REGISTRATION to Samuel Lowe for an Improved Clothes-washing Machine.

[Registered on the 13th day of June, 1883, in pursuance of the Act 16 Vic. No. 24.]

BY HIS EXCELLENCY THE RIGHT HONORABLE SIR AUGUSTUS WILLIAM FREDERICK SPENCER LOFTUS (commonly called LORD AUGUSTUS LOFTUS), Knight Grand Cross of the Most Honorable Order of the Bath, a Member of Her Majesty's Most Honorable Privy Council, Governor and Commander-in-Chief of the Colony of New South Wales and its Dependencies.

TO ALL TO WHOM THESE PRESENTS SHALL COME, greeting:

WHEREAS SAMUEL LOWE, of No. 4, Byrne's Arcade Terrace, Simpson's Road, Richmond, in the Colony of Victoria, merchant, hath by his Petition humbly represented to me that he is the author or designer of a certain invention or improvement in manufactures, that is to say, of an invention entitled "An Improved Clothes-washing Machine," which is more particularly described in the specification and the sheet of drawings which are hereunto annexed; and that he, the said Petitioner, hath deposited with the Honorable the Treasurer of the said Colony of New South Wales the sum of Twenty Pounds sterling, for defraying the expense of granting these Letters of Registration, as required by the Act of Council, sixteenth Victoria, number twenty-four; and hath humbly prayed that I would be pleased to grant Letters of Registration, whereby the exclusive enjoyment and advantage of the said invention or improvement might be secured to him for a period of fourteen years: And I, being willing to give encouragement to all inventions and improvements in the arts or manufactures which may be for the public good, and having received a report favourable to the prayer of the said Petition, from competent persons appointed by me to examine and consider the matter stated therein and to report thereon for my information, am pleased, with the advice of the Executive Council, and in exercise of the power and authority given to me by the said Act of Council, to grant, and do by these Letters of Registration grant unto the said Samuel Lowe, his executors, administrators, and assigns, the exclusive enjoyment and advantage of the said invention or improvement, for and during the term of fourteen years from the date hereof; to have, hold, and exercise unto the said Samuel Lowe his executors, administrators, and assigns, the exclusive enjoyment and advantage thereof, for and during and unto the full end and term of fourteen years from the date of these presents next and immediately ensuing, and fully to be complete and ended: Provided always, that if the said Samuel Lowe shall not, within three days after the granting of these Letters of Registration, register the same in the proper office in the Supreme Court, at Sydney, in the said Colony of New South Wales, then these Letters of Registration, and all advantages whatsoever hereby granted, shall cease and become void.

In witness whereof, I have hereunto set my sign manual, and have caused the present Letters of Registration to be sealed with the seal of the said Colony of New South Wales, at Government House, Sydney, in New South Wales, this twelfth day of June, in the year of our Lord one thousand eight hundred and eighty-three.

[L.S.]

AUGUSTUS LOFTUS.

*An Improved Clothes-washing Machine.*

SPECIFICATION of SAMUEL LOWE, of No. 4, Byrne's Arcade Terrace, Simpson's Road, Richmond, in the Colony of Victoria, merchant, for an invention entitled "An Improved Clothes-washing Machine."

My improved clothes-washing machine consists of a drum-shaped vessel revolving inside a closed box, the clothes being placed in the drum, and a few inches of water in the box. The water in the box is heated, and it and the steam produced by it pass through openings for the purpose across the periphery of the drum, and thus cleanse the clothes. In addition to, and alternately with, the openings across the periphery of the drum there are indentations made which produce sloping shelves on the inside, so as to assist in turning over the clothes under treatment. The ends of the drum are strengthened by radial stays, and for convenience of heating by gas I sometimes provide a stand on which the box rests.

Referring to my drawings, figures 1 and 2 show front and end view of one of my machines complete and mounted on a suitable stand. Figure 3 shows top view of drum. Figure 4, section on line *a b* in figure 3, and figure 5 sectional elevation on same line showing the radial stays at end of drum. Figure 6 is plan of stand. Figure 7 detail of half-bearing in side of box. A is the drum-shaped vessel having openings A<sup>1</sup> and indentations A<sup>2</sup> quite across its periphery, and radial stays A<sup>3</sup> at each end. A<sup>4</sup> is a hinged lid, fastened by hook and eye A<sup>5</sup>. The drum has pintles, A<sup>6</sup> and A<sup>7</sup>, fixed to its ends, which work in half-bearings fastened to inside of box (as shown in detail in figure 7.) To a bolt, A<sup>8</sup>, passing through square hole in pintle A<sup>7</sup>, the handle, A<sup>9</sup>, is fixed outside the closed box. B is the box having removable arched lid B<sup>1</sup>, with its handle B<sup>2</sup>, and which fits on like the lid of an ordinary saucpan. Outside said box, and underneath the handle, is a cup, B<sup>3</sup>, for catching any liquid that may ooze out. B<sup>4</sup>B<sup>4</sup> are handles for lifting the machine on and off the stand, C, which is simply a metal plate supported on legs C<sup>1</sup>, and having air holes, C<sup>2</sup>, gas pipe, C<sup>3</sup>, two round supports, C<sup>4</sup>, and four corner ones, C<sup>5</sup>, for the box B to rest upon. This stand C is not an essential part of the machine, as the box B and its contained drum A can be lifted on to any conveniently shaped fireplace and be heated by a fire; or it may be placed anywhere, so long as provision is made for heating the water.

The clothes to be washed should be first rinsed in water and rubbed with soap, and then placed in the drum A. The lid, A<sup>4</sup>, should then be fastened and the lid, B<sup>1</sup>, placed on the box, B. The water in the box must then be heated, and the handles A<sup>9</sup> turned slowly round. As it revolves it takes up a little of the water in the box through openings, A<sup>1</sup>, by which means also steam is allowed to enter. A very short time suffices to cleanse the clothes, but of course, that depends on the nature of the articles treated, and their degree of dirtiness. When the water is sufficiently dirty it must be replaced by clean.

Having thus described the nature of my invention, and the method of performing same, I would have it understood that I do not confine myself to the size or shape of the several parts of my machine so long as its nature and essence be retained, neither do I confine myself to any particular material of which it may be made or manufactured, although I prefer to make it wholly of metal, but what I believe to be new, and therefore claim as my invention is:—

My improved clothes washing machine, consisting of the combination of my revolving drum-shaped vessel A, with its containing box B, substantially as herein described and explained.

In witness whereof, I the said Samuel Lowe, have hereto set my hand and seal, this ninth day of April, one thousand eight hundred and eighty-three.

SAMUEL LOWE.

Witness—

P. A. SMITH,  
Clerk to Edward Waters,  
Patent Agent Melbourne.

This is the specification referred to in the annexed Letters of Registration granted to Samuel Lowe, this 12th day of June, A.D. 1883.

AUGUSTUS LOFTUS.

### REPORT.

Sir, In accordance with your B.C. minute of the 14th instant, on the application of Mr. Samuel Lowe, dated 12th April, for Letters of Registration for an invention entitled "An Improved Clothes-washing Machine," we have to report that we see no reason why the request should not be complied with.

Sydney, 23 April, 1883.  
We have, &c.,  
JAMES BARNET.  
WILLIAM C. BENNETT.

The Under Secretary of Justice.

**SAM'L LOWE'S PATENT**

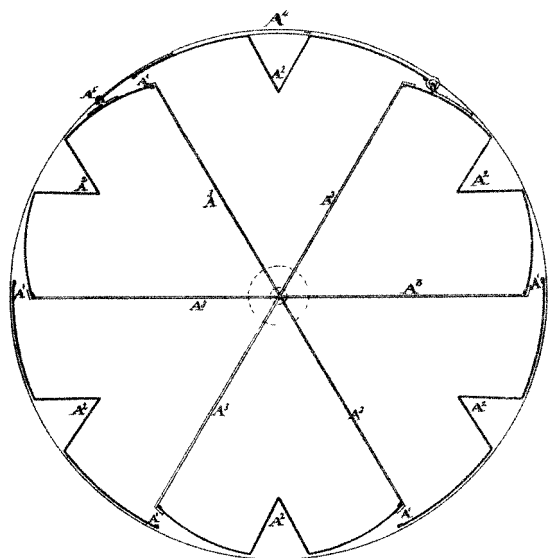


Fig. 5.

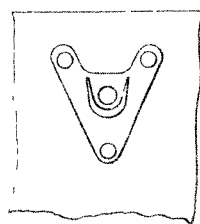


Fig. 7.

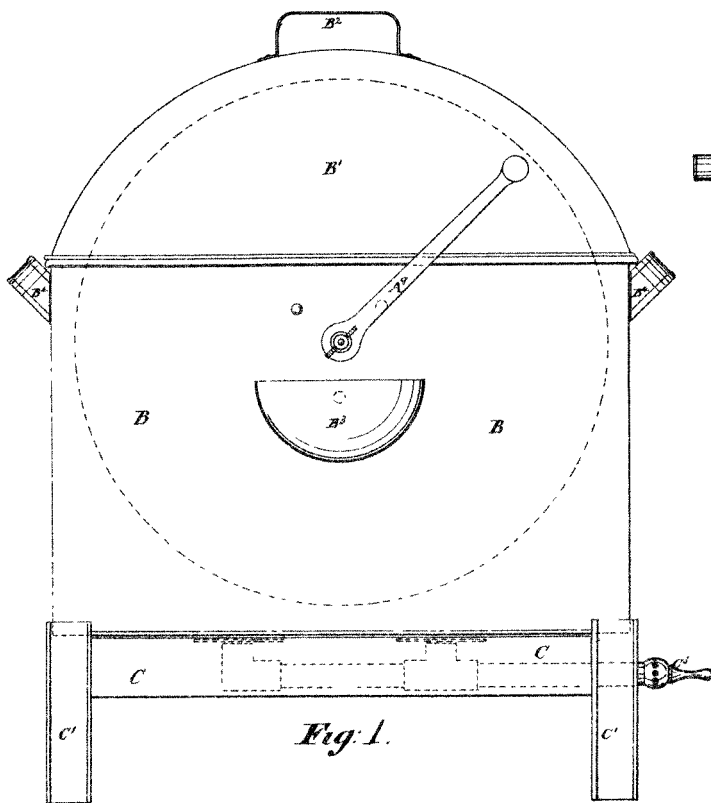


Fig. 1.

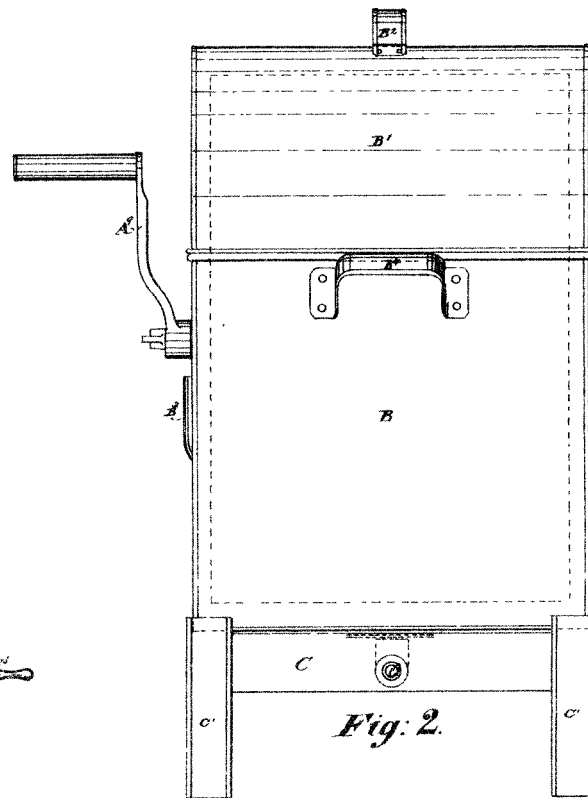


Fig. 2.

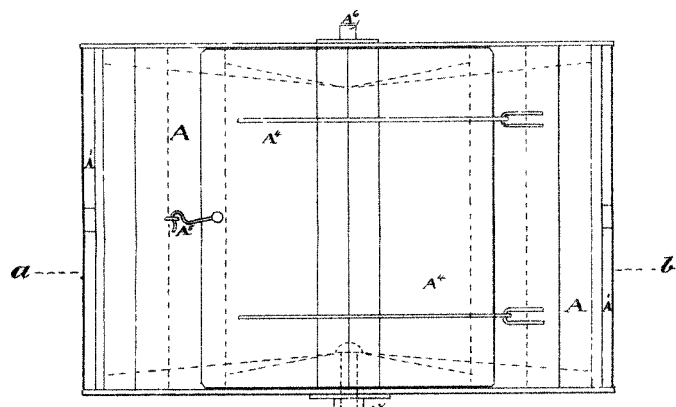


Fig. 3.

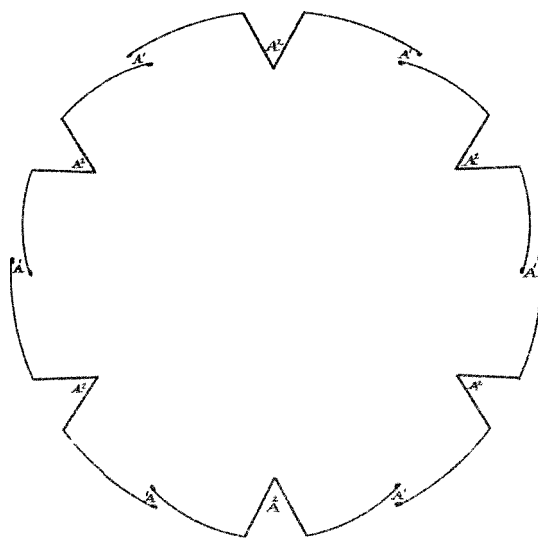


Fig. 4.

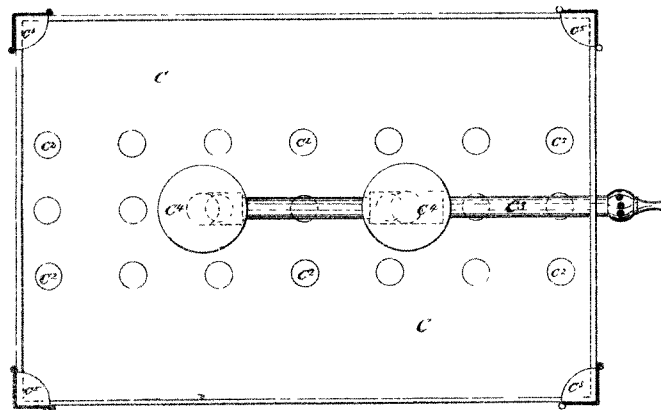


Fig. 6.

*This is the Sheet of Drawings referred to in the annexed Letters of Registration granted to Samuel Lowe this 12<sup>th</sup> day of June A. D. 1883.*

*Augustus Loftus.*





A.D. 1883, 12th June. No. 1259.

AN IMPROVED BUFFER FOR CAB AND OTHER HINGED DOORS.

LETTERS OF REGISTRATION to Walter Bowness Benns for an Improved Buffer  
for Cab and other Hinged Doors.

[Registered on the 13th day of June, 1883, in pursuance of the Act 16 Vic. No. 24.]

BY HIS EXCELLENCY THE RIGHT HONORABLE SIR AUGUSTUS WILLIAM FREDERICK SPENCER LOFTUS (commonly called LORD AUGUSTUS LOFTUS), Knight Grand Cross of the Most Honorable Order of the Bath, a Member of Her Majesty's Most Honorable Privy Council, Governor and Commander-in-Chief of the Colony of New South Wales and its Dependencies.

TO ALL TO WHOM THESE PRESENTS SHALL COME, greeting :

WHEREAS WALTER BOWNESS BENNS, of Sydney, in the Colony of New South Wales, hath by his Petition humbly represented to me that he is the author or designer of a certain invention or improvement in manufactures, that is to say, of an invention entitled "An Improved Buffer for Cab and other Hinged Doors," which is more particularly described in the specification, with drawing therein, which is hereunto annexed; and that he, the said Petitioner, hath deposited with the Honorable the Treasurer of the said Colony of New South Wales the sum of Twenty Pounds sterling, for defraying the expense of granting these Letters of Registration, as required by the Act of Council, sixteenth Victoria, number twenty-four; and hath humbly prayed that I would be pleased to grant Letters of Registration, whereby the exclusive enjoyment and advantage of the said invention or improvement might be secured to him for a period of fourteen years: And I, being willing to give encouragement to all inventions and improvements in the arts or manufactures which may be for the public good, and having received a report favourable to the prayer of the said Petition, from competent persons appointed by me to examine and consider the matters stated therein and to report thereon for my information, am pleased, with the advice of the Executive Council, and in exercise of the power and authority given to me by the said Act of Council, to grant, and do by these Letters of Registration grant unto the said Walter Bowness Benns, his executors, administrators, and assigns, the exclusive enjoyment and advantage of the said invention or improvement for and during the term of fourteen years from the date hereof; to have, hold, and exercise unto the said Walter Bowness Benns, his executors, administrators, and assigns, the exclusive enjoyment and advantage thereof, for and during and unto the full end and term of fourteen years from the date of these presents next and immediately ensuing, and fully to be complete and ended: Provided always, that if the said Walter Bowness Benns shall not, within three days after the granting of these Letters of Registration, register the same in the proper office in the Supreme Court, at Sydney, in the said Colony of New South Wales, then these Letters of Registration, and all advantages whatsoever hereby granted, shall cease and become void.

In witness whereof, I have hereunto set my sign manual, and have caused the present Letters of Registration to be sealed with the seal of the said Colony of New South Wales, at Government House, Sydney, in New South Wales, this twelfth day of June, in the year of our Lord one thousand eight hundred and eighty-three.

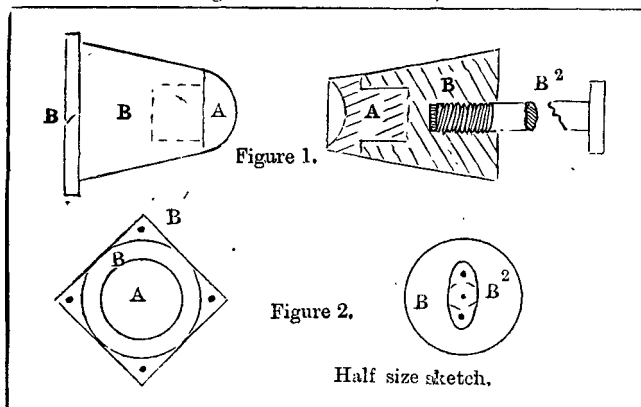
[L.S.]

AUGUSTUS LOFTUS.

*An Improved Buffer for Cab and other Hinged Doors.*

SPECIFICATION of WALTER BOWNESS BENNS, of Sydney, in the Colony of New South Wales, the author or designer of an invention entitled "An Improved Buffer for Cab and other Hinged Doors." My inventions consists of an improved buffer or elastic cushion for cab and other hinged doors, and has been designed in order to overcome or minimise the jar caused (and more especially in hansom cabs) by the opening of the doors.

My improved buffer consists of a vulcanized India-rubber or other similar elastic cushion held in a socket having a flange stem or other means of attachment. I generally use the buffers in pairs, the cushion of one being concave at its head, while the cushion of the other has a convex head.



In the sketch in the margin hereof, figure 1 is a section and elevation of a pair of the buffers, and figure 2 end views thereof. A is the elastic cushion, and B the socket. B<sup>1</sup> is flange, and B<sup>2</sup> a stem, the latter screwed into socket B. Although I have only shown these two methods of attachment, and on reverse buffers it is plain that other means might be used, or they might both have stems or flanges, as the case may be.

In practice I take one or more pairs of the buffers and fix the concave ones to the frame at such a point that the convex ones will rest in them when the door is open the required distance. When the doors are thrown open the elastic buffers take the

force, and, in the case of vehicles, give a yielding seat to the doors, thus preserving the hinges and minimising any movement due to jolting upon the road.

I claim my improved buffer for cab and other hinged doors, formed of the elastic cushion, A, held in a socket, B, having means of attachment to a door or framework, and such cushions having concave and convex heads, so that one may rest within the other when a pair is used, substantially as herein described and explained.

In witness whereof, I, the said Walter Bowness Benns, have hereto set my hand and seal, this day of \_\_\_\_\_ one thousand eight hundred and eighty-three.

WALTER B. BENNS.

This is the specification, with drawing, referred to in the annexed Letters of Registration granted to Walter Bowness Benns this 12th day of June, A.D 1883.

AUGUSTUS LOFTUS.

### REPORT.

Sir,

The application of Mr. W. B. Benns for Letters of Registration for "An Improved Buffer for Cab and other Hinged Doors" having been referred to us, we have examined the drawing and description accompanying the same, and have now the honor to report that we see no objection to the issue of Letters of Registration as prayed for.

The Under Secretary of Justice.

Sydney, 8 May, 1883.

We have, &c.,

JAMES BARNET.

WILLIAM C. BENNETT.

### No. 1260.

[Assignment of New South Wales Letters of Registrations, dated 26th day of August, 1882.]



A.D. 1883, 27th June. No. 1261.

**IMPROVEMENTS IN THE MANUFACTURE OF SILICIOUS COPPER AND SILICIOUS BRONZE.**

**LETTERS OF REGISTRATION** to Lazare Weiller, for Improvement in the manufacturing of Silicious Copper and Silicious Bronze, particularly suited for making Electric Conducting Wire, which is more particularly described in the specification which is hereunto annexed.

[Registered on the 28th day of June, 1883, in pursuance of the Act 16 Vic. No. 24.]

BY HIS EXCELLENCY THE RIGHT HONORABLE SIR AUGUSTUS WILLIAM FREDERICK SPENCER LOFTUS (commonly called LORD AUGUSTUS LOFTUS), Knight Grand Cross of the Most Honorable Order of the Bath, a Member of Her Majesty's Most Honorable Privy Council, Governor and Commander-in-Chief of the Colony of New South Wales and its Dependencies.

TO ALL TO WHOM THESE PRESENTS SHALL COME, greeting:

WHEREAS LAZARE WEILLER, of Angoulême, France, hath by his Petition humbly represented to me that he is the author or designer of a certain invention or improvement in manufactures, that is to say, of an invention entitled "Improvements in the manufacture of Silicious Copper and Silicious Bronze, particularly suited for making Electric Conducting Wires," which is more particularly described in the specification which is hereunto annexed; and that he, the said Petitioner hath deposited with the Honorable the Treasurer of the said Colony of New South Wales the sum of Twenty Pounds sterling, for defraying the expense of granting these Letters of Registration, as required by the Act of Council, sixteenth Victoria, number twenty-four; and hath humbly prayed that I would be pleased to grant Letters of Registration, whereby the exclusive enjoyment and advantage of the said invention or improvement might be secured to him for a period of fourteen years: And I, being willing to give encouragement to all inventions and improvements in the arts or manufactures which may be for the public good, and having received a report favourable to the prayer of the said Petition from competent persons appointed by me to examine and consider the matters stated therein and to report thereon for my information, am pleased, with the advice of the Executive Council, and in exercise of the power and authority given to me by the said Act of Council, to grant, and do by these Letters of Registration grant unto the said Lazare Weiller, his executors, administrators, and assigns, the exclusive enjoyment and advantage of the said invention or improvement, for and during the term of fourteen years from the date hereof; to have, hold, and exercise unto the said Lazare Weiller his executors, administrators, and assigns, the exclusive enjoyment and advantage thereof, for and during and unto the full end and term of fourteen years from the date of these presents next and immediately ensuing, and fully to be complete and ended: Provided always, that if the said Lazare Weiller shall not, within three days after the granting of these Letters of Registration, register the same in the proper office in the Supreme Court, at Sydney, in the said Colony of New South Wales, then these Letters of Registration, and all advantages whatsoever hereby granted, shall cease and become void.

In witness whereof, I have hereunto set my sign manual, and have caused the present Letters of Registration to be sealed with the seal of the said Colony of New South Wales, at Government House, Sydney, in New South Wales, this twenty-seventh day of June, in the year of our Lord one thousand eight hundred and eighty-three.

[L.S.]

AUGUSTUS LOFTUS.

*Improvements in the manufacture of Silicious Copper and Silicious Bronze, &c.*

SPECIFICATION of LAZARE WEILLER, of Angoulême, France, for an invention entitled "Improvements in the manufacture of Silicious Copper and Silicious Bronze, particularly suited for making Electric Conducting Wires."

THE idea of adding silicium to copper is not new, but the processes hitherto suggested have necessitated the preparation of a pure silicium; sodium has also to be added to prevent oxidation during the process of casting.

Now, as it has been ascertained that silicious compounds of copper are particularly suited for making electric conducting wires, the object of the present invention is to manufacture them in a commercial and economical manner.

The invention consists in an improved process of manufacture, wherein substances such as are hereinafter specified are introduced into the melted copper or bronze in such a manner that by their reactions they are capable of furnishing in the midst of the molten mass itself the requisite silicium and sodium, which by their association with the molten metal will produce silicious alloys, or compounds of copper and bronze. The use of expensive and specially prepared forms of silicium and sodium is thus avoided, and the process of manufacturing the required alloy is effected in an efficient and economical manner by producing them concurrently with the silicious compound itself, by the agency of substances that may be easily procured at a cheap rate, but which have not been used for the purpose in question.

Into a plumbago crucible containing about 10 kilogrammes (about 22 lb.) of copper, I introduce a quantity of the following mixture, varying from 100 to 2,000 grammes (about 3½ oz. to 4 lb. 6 oz.) according to the degree of conductivity required in the wire to be subsequently manufactured.

Fluosilicate of potass from about 22.5 to 450 grammes	(about 347 grains to 1 lb.)
Pounded glass from about 30 to 600	" (about 463 grains to 1 lb. 5 oz.)
Chloride of sodium from about 12.5 to 250	" (about 193 grains to 9 oz.)
Carbonate of soda from about 5 to 100	" (about 77 grains to 3½ oz.)
Carbonate of lime from about 6 to 120	" (about 92 grains to 4½ oz.)
Chloride of calcium (dry) from about 25 to 500	" (about 386 grains to 1 lb. 1½ oz.)

The pounded glass and the chloride of calcium may be omitted, but in this case the proportion of the fluosilicate of potass should be increased; for the two outside limits above cited, it would be from 37 to 740 grammes (about 1½ oz. to 1 lb. 10 oz.)

This mixture should be raised in a suitable vessel to a temperature approaching, but lower than that at which the different bodies can enter into reaction; it is then thrown into the melted copper or bronze. Owing to the higher temperature of this metal the reactions are produced, and the silicium and sodium in combining with the metal absorb all the oxides present in the mass.

While the operation of manufacturing the silicious copper and silicious bronze may be well effected by the employment of the ingredients hereinbefore named, it will be facilitated by the addition of a small quantity of carbon towards the end of the process, as will be well understood by persons conversant with the nature of similar operations.

The chloride of calcium present in the mixture serves to absorb the scoriæ as they are formed.

For the quantity of materials above given for the mixture, the quantity of the metal is for copper alone 10 kilogrammes (about 22 lbs.) as has been already herein mentioned, and for bronze 10 kilogrammes of copper and from 20 to 450 grammes (about 309 grains to 1 lb.) of tin.

The proportion of tin to that of the copper in the alloy or compound may vary, as will be well understood, and the quantities of the ingredients employed should be varied with any change in the quantity of copper present, as will be well understood by persons experienced in the manufacture of alloys of copper.

When the reactions are finished, the metallic alloy is run into bars, and drawn through a suitable drawplate; one made of diamond may be employed, so as to draw it into wires of the required size.

The conductivity of the alloys manufactured by the improved process above described is about 61 per cent. of that of copper, and four times more than that of iron.

With equal conductivity the weight of the wires is one-fourth that of iron wires, and one-fifth that of steel wires.

The presence of the silicium gives to the copper and bronze a resistance to rupture equal to that of steel.

These qualifications render the silicious copper and bronze particularly adapted for the manufacture of wires for telephonic, telegraphic, and other electrical purposes. The silicious bronze is preferred.

Owing to the light weight and diameter of the telegraph wires formed of these silicious compounds, the wind has less effect upon them, and this leads to an economy in the posts.

The proportions of the materials hereinbefore stated can be varied within the limits hereinbefore named, and thus an electric conductivity of 81 per cent. of that of copper can be reached with a rupture strain of about 50 kilogrammes (about 110 lbs.) per square millimetre (about 0.155 square inch.)

Having thus fully described the said invention and the manner of performing the same, I wish it understood that I claim—

1st—The process hereinbefore described of producing silicious copper and silicious bronze, by introducing into melted copper or bronze a mixture such as herein specified, and containing substances which by their reaction in the midst of the molten mass itself will furnish the silicium and sodium necessary for the formation of the said silicious compounds as hereinbefore set forth.

2nd—The manufacture of silicious copper and silicious bronze by the employment of the materials hereinbefore named, and in the manner substantially as set forth.

In witness whereof, I, the said Lazare Weiller, have hereto set my hand and seal, this twenty-second day of February, 1883.

Witness—

WILLIAM WARD,

Her Britannic Majesty's Consul at Bordeaux.

L. WEILLER.

This

---

*Improvements in the manufacture of Silicious Copper and Silicious Bronze, &c.*

---

This is the specification referred to in the annexed Letters of Registration granted to Lazare Weiller, this twenty-seventh day of June, A.D. 1883.

AUGUSTUS LOFTUS.

---

REPORT.

---

Sir,

We do ourselves the honor to report, in reply to your blank cover minute of the 7th instant, No. 5,714, that we are of opinion that Letters of Registration may be granted in favour of Lazare Weiller for an invention entitled "Improvements in the manufacture of Silicious Copper and Silicious Bronze, particularly suited for making Electric Conducting Wires," in accordance with his Petition, specification, and claim.

Sydney, 11 May, 1883.  
We have, &c.,

E. C. CRACKNELL.  
GOTHER K. MANN.

The Under Secretary of Justice.

---



A.D. 1883, 27th June. No. 1262.

**IMPROVEMENTS IN APPARATUS FOR AUTOMATICALLY MANIPULATING THE CURRENT EMPLOYED IN CHARGING SECONDARY BATTERIES OR MAGAZINES OF ELECTRICITY.**

**LETTERS OF REGISTRATION** to Charles Francis Brush, for Improvements in Apparatus for automatically manipulating the Current employed in Charging Secondary Batteries or Magazines of Electricity.

[Registered on the 23th day of June, 1883, in pursuance of the Act 16 Vic. No. 24.]

BY HIS EXCELLENCY THE RIGHT HONORABLE SIR AUGUSTUS WILLIAM FREDERICK SPENCER LOFTUS (commonly called LORD AUGUSTUS LOFTUS), Knight Grand Cross of the Most Honorable Order of the Bath, a Member of Her Majesty's Most Honorable Privy Council, Governor and Commander-in-Chief of the Colony of New South Wales and its Dependencies.

TO ALL TO WHOM THESE PRESENTS SHALL COME, greeting :

WHEREAS CHARLES FRANCIS BRUSH, of Cleveland, United States of America, Electrical Engineer, hath by his Petition humbly represented to me that he is the author or designer of a certain invention or improvement in manufactures, that is to say, of an invention entitled "Improvements in Apparatus for automatically manipulating the current employed in charging Secondary Batteries or Magazines of Electricity," which is more particularly described in the specification and the sheet of drawings which are hereunto annexed; and that he, the said Petitioner, hath deposited with the Honorable the Treasurer of the said Colony of New South Wales the sum of Twenty Pounds sterling, for defraying the expense of granting these Letters of Registration, as required by the Act of Council, sixteenth Victoria, number twenty-four; and hath humbly prayed that I would be pleased to grant Letters of Registration, whereby the exclusive enjoyment and advantage of the said invention or improvement might be secured to him for a period of fourteen years: And I, being willing to give encouragement to all inventions and improvements in the arts or manufactures which may be for the public good, and having received a report favourable to the prayer of the said Petition, from competent persons appointed by me to examine and consider the matters stated therein, and to report thereon for my information, am pleased, with the advice of the Executive Council, and in exercise of the power and authority given to me by the said Act of Council, to grant, and do by these Letters of Registration grant unto the said Charles Francis Brush, his executors, administrators, and assigns, the exclusive enjoyment and advantage of the said invention or improvement, for and during the term of fourteen years from the date hereof; to have, hold, and exercise unto the said Charles Francis Brush, his executors, administrators, and assigns, the exclusive enjoyment and advantage thereof, for and during and unto the full end and term of fourteen years from the date of these presents next and immediately ensuing, and fully to be complete and ended: Provided always, that if the said Charles Francis Brush shall not, within three days after the granting of these Letters of Registration, register the same in the proper office in the Supreme Court, at Sydney, in the said Colony of New South Wales, then these Letters of Registration, and all advantages whatsoever hereby granted, shall cease and become void.

In witness whereof, I have hereunto set my sign manual, and have caused the present Letters of Registration to be sealed with the seal of the said Colony of New South Wales, at Government House, Sydney, in New South Wales, this twenty-seventh day of June, in the year of our Lord one thousand eight hundred and eighty-three.

[L.S.]

AUGUSTUS LOFTUS.

*Improvements in Secondary Batteries and Magazines of Electricity.*

SPECIFICATION OF CHARLES FRANCIS BRUSH, of Cleveland, United States of America, Electrical Engineer, for an invention entitled "Improvements in Apparatus for automatically manipulating the Current employed in charging Secondary Batteries or Magazines of Electricity."

FOR the sake of convenience in describing and referring to the various embodiments of the invention that I shall herein set forth, I shall specify them separately and successively, and distinguish each alphabetically.

## DIVISION G.

"Division G" of my invention relates to secondary batteries, and it consists in devices now to be described (or their equivalent) for automatically manipulating the current employed in charging such batteries.

The devices for this purpose are such, that (1st) when no current is acting in the charging circuit, the one or more batteries in connection therewith will be open-circuited, so far as the charging circuit is concerned, and the latter will be short-circuited, around each battery; also (2nd), when the charging current is established in the charging circuit or line, the "short circuit" around each battery will be opened, and the battery thrown into circuit. Again, when the charging current stops, each battery will be thrown out of circuit, and the line "short-circuited" as at first.

These automatic operations prevent the inverse discharge of the batteries through the charging line, when the charging current is discontinued, prevent reversal of polarity in the dynamo machine, when such is employed for charging, and leave a close circuit for the charging current to re-establish itself in when re-charging or continued charging of the batteries is desired. If desirable, a suitable passive resistance may be placed in, or substituted for, the "short circuit" before alluded to, in order to offer a normal, or approximately normal, resistance for the charging current to establish itself in before the automatic apparatus shall have thrown the battery into circuit. This resistance also lessens the spark which occurs when the "short circuit" is opened at the time of throwing the battery into the charging circuit.

In the drawings, Fig. 9 represents my automatic device, wherein the "short circuit" is not provided with a resistance.

Fig. 10 shows the device provided with a resistance in the "short circuit."

Fig. 11 shows a system wherein three secondary batteries are charged in series by the same current, each battery being provided with the automatic apparatus.

Fig. 12 illustrates a system wherein three batteries, each provided with the automatic apparatus, are charged in "multiple-arc" from one source of current.

Fig. 13 represents a system wherein four batteries are charged in "series" by the same current, one automatic apparatus controlling the current for all.

Fig. 14 illustrates a system wherein three batteries are charged in "multiple-arc," one automatic apparatus controlling the current for all.

In Fig. 9, A represents a current generator, which may consist of a dynamo-electric machine, thermo-electric, or other apparatus capable of furnishing current. B is a secondary battery. C is an electro-magnet, located in the circuit  $a, a^1, a^2, a^3$ , connecting the generator and battery. D represents a number of electric lamps, or other electro-receptive devices. E is a lever, pivoted at  $b$ , and provided with an armature at  $c$ , facing the pole or poles of the magnet C. The lever E may be of iron, and the armature  $c$  dispensed with. The lever E may be provided with an adjustable weight  $d$ . The free end of the lever carries contact points  $e, f$ , which are insulated from each other.  $g$  is a stationary contact point, which makes contact with  $f$ , and serves as a stop to the lever E when the latter rises in obedience to the attraction of the magnet C.

The contact  $g$  is connected with the charging circuit  $a$ , as is also the contact  $c$ , by means of a flexible connection, as shown.

The contact  $f$  is also connected by a flexible conductor with the charging circuit  $a$ .  $h$  is a stationary contact point which makes contact with  $e$ , and serves as a stop to the lever E when the latter falls.

$h$  is connected by a conductor F of low resistance, with the charging circuit  $a^2$ .

A conductor of the fusible metal H, may be employed for the purpose of opening that part of the circuit by fusion, if the charging or discharging current becomes greatly abnormal in quantity from any cause.

The diagram just explained shows the lever E in the position which it occupies while the generator A is charging the battery B. The current passes from the generator through the line  $a$ , contacts  $g, f$ , line  $a^1$ , conductor H, battery B, line  $a^2$ , magnet C, and line  $a^3$  back to the generator. When the charging current stops, or becomes greatly reduced, the magnet C being no longer able to support the lever E, the latter drops, separating the contacts  $g, f$ , and making contact between  $e$  and  $h$ .

Thus, the end H of the battery B is disconnected from the charging-line  $a$ , and the circuit of the generator is completed through another path, viz., through the line  $a$ , contacts  $e, h$ , conductor F, line  $a^2$ , magnet C, and line  $a^3$ .

When the charging current is again started, the magnet C raises the lever E into the position shown in the diagram, and the charging of the battery B is resumed.

The electro-receptive devices D here shown, as arranged in "multiple-arc," are operated by the discharge of the battery B when the charging current from the generator is not acting.

If they are left in circuit while the charging current is acting, they may be regarded as being operated wholly or in part by the charging current direct. If they require less than the charging current, the excess of the latter will pass through the battery B, augmenting its charge; if they require more than the charging current, the latter will be supplemented by a discharge from the battery.

Fig. 10 shows a resistance G, in place of the conductor F of Fig. 9. This resistance may be made adjustable if desired.

Fig. 10 also shows various electro-receptive devices to be operated, such as arc and incandescent lamps, and electro-motors. It also shows these electro-receptive devices arranged both in "multiple-arc" and in "series." Figs.

*Improvements in Secondary Batteries and Magazines of Electricity.*

Figs. 11, 12, 13, and 14 show systems wherein generators A, circuits *a a*, automatic current controlling devices K, secondary batteries B, and electro-receptive devices D, are variously associated and combined, as has been hereinbefore described.

I prefer to make the contact points *e, f, g, h*, Fig. 9, of carbon, such as is used in electric-arc lighting, so that their surfaces may not become impaired by the sparks which may occur between them. Obviously, an axial magnet with movable core may be employed instead of the form shown at C.

When the lever E, Fig. 9, rises, a spark or arc must be formed between the points *e* and *h* during the time the lever is moving, and until contact is established between *f* and *g*.

The ultimate distance apart of *e* and *h* is so adjusted that the resistance to the passage of current offered by the spark or arc between these points is considerable, or even greater than that offered by the battery B, so that when *f g* make contact, the passage of current between *e* and *h* ceases. When a resistance G, Fig. 10, is placed in the "short circuit" F, of Fig. 9, the points *e h* may be worked at a less separation, and the spark or arc between them greatly reduced. This is because the resistance G replaces more or less of that which was in the first instance necessarily in the spark between *e* and *h*.

## DIVISION H.

"Division H" of the invention also relates to secondary batteries, and it consists in devices hereinafter described, or their equivalent, for automatically manipulating the current employed in charging such batteries. The devices for this purpose are such that (1st) when no current is acting in the charging circuit, the one or more batteries in connection therewith will be open-circuited, so far as the charging circuit is concerned, and the latter will be short-circuited around each battery; also (2nd), when the charging current is fully established in the charging circuit or line, the "short circuit" around each battery will be opened, and the battery thrown into circuit; also (3rd), when each battery becomes fully charged, it will, independently of any other battery in the charging circuit, be thrown out of the charging circuit, and the latter will be "short-circuited" around the battery as at first. Again, when the charging current stops, or becomes greatly lessened, each battery, whether fully charged or not, will be thrown out of circuit, and the line "short-circuited" as before; also (4th), while the charging current is acting, each battery, whether fully charged or not, may be automatically disconnected from its individual working or discharging circuit.

These automatic operations prevent the inverse discharge of the batteries through the charging line when the charging current is discontinued; prevent reversal of polarity of the dynamo-machine when such is employed for charging; leave a closed circuit for the charging current to re-establish itself in when re-charging or continued charging of the battery is desired; and avoid waste of current energy by stopping the current through a battery when the latter is fully charged.

Other important advantages attend the use of the automatic apparatus, as will appear later in the specification of this division of the invention.

The automatic apparatus, although well adapted to control the charging of a single secondary battery, is especially designed to regulate the charging, from a single circuit-source, of many batteries.

Each battery may consist of any desired number of elements, or cells, irrespective of the number of elements in any other battery. The several batteries may be charged in "multiple-arc," or "series-multiple-arc," or in simple "series." The latter is the preferable method, and is the one I shall more particularly describe. In order to secure *all* of the advantages pertaining to this division of the invention, each battery should, in either case, be provided with current-controlling device.

I have specified that when a battery becomes fully charged, it will be thrown out of circuit, and the latter closed through another channel. This may, and generally will occur while the charging current is in full force. In the performance of this operation it certainly will not do to close the "short circuit" around the battery before disconnecting the latter from the line, because then the battery would at once commence to discharge itself with very great energy through this short circuit, and the subsequent disconnection of the battery from the line would be attended by the destruction of the parts where the break occurred.

On the other hand, the battery could not be entirely disconnected from the charging line before closing the "short circuit," as this would entail the stoppage of the current in the whole system of batteries. A partial break might be made by establishing an arc at one end of the battery, long enough to prevent the discharge of the latter across the interval when the "short circuit" is established; but this would be very objectionable, not only on account of the burning of the points where the separation occurs, but because of the extra resistance (that of the arc) suddenly introduced into the charging circuit. Obviously, similar difficulties would occur in throwing a battery into the charging circuit.

I avoid these difficulties by using a resistance, and by making the operation of throwing a battery out of, or into, the charging circuit consist of a series of steps as follows:—In throwing a battery out of circuit, the first step consists in the introduction of a resistance parallel with the battery, between which and the battery the charging current may divide itself; but I make this resistance so small that substantially the whole of the charging current passes through it, while at the same time the resistance is great enough, being occupied by the charging current, to prevent a discharge from the battery through it.

The next step disconnects the battery from the line, leaving in lieu thereof the resistance.

The third step "short-circuits" the resistance and completes the operation. Thus, a battery may be thrown out of the charging line without any disturbance of the latter's current, and without any sparks whatever, if the resistance be carefully adjusted. Even if the resistance is only approximately adjusted, the sparks will be small and entirely harmless. In throwing a battery into the charging circuit these steps are reversed. First, the "short circuit" is opened, throwing the current into the resistance. This will, of course, be attended by a flash, which, however, is comparatively small, and is harmless. This flash may be divided into a number of much smaller ones, by introducing successively increasing resistances; but this is an entirely unnecessary refinement, and I will not again allude to it, after stating here that while I prefer to use a single resistance, I do not wish to be understood as confining myself to it. The next step connects the battery, and the third and last step opens the resistance, throwing all of the current through the battery. This last step will, of course, be attended by another flash, which, however, is smaller than the first, and quite unimportant.

When



*Improvements in Secondary Batteries and Magazines of Electricity.*

When the charging current stops, or diminishes in the act of stopping or otherwise, then any battery which has not already become fully charged and switched itself out of the circuit will be thrown out by the same series of operations which would have occurred had it been previously fully charged.

In designing and adjusting the automatic mechanism, I prefer to so arrange matters that the function of throwing the batteries into the charging circuit, which is exercised when the charging current is established, shall not be called into action until the charging current has approximately reached its normal strength. By this precaution I secure an advantage of much importance when a large number of batteries are to be charged.

I have neglected to mention that one of the objects of this division of the invention is to provide for the unequal use of the several batteries of a system between or during the times of charging, and here call attention to this point as an aid to my present explanation. I will also add that I contemplate locating the several batteries of the system, not necessarily in one place, but at many points, which may be widely separated, to the end that the batteries may be independently employed in different buildings or localities for lighting or other purposes, all the batteries being connected by the charging line. Suppose, now, that we have a hundred or more batteries all connected with one charging line, and that the dynamo-machine used for charging is capable of simultaneously charging, say, twenty batteries only. Suppose, also, that the hundred batteries have been unequally exhausted since the last time of charging. Now, since it would be impossible to so adjust the automatic devices pertaining to the several batteries that the latter would all be thrown into the circuit by the same strength of current, it follows that, as the charging machine is set in motion and the charging current approaches normal strength, first one battery (that whose current-regulating device responds to the least current) will be thrown into circuit, then another, and so on until any further increase of current will be prevented by the opposing electro-motive force of the batteries already in circuit. We will now have, say, twenty batteries in circuit, and these will continue to receive the charge until one or more of them (those of the twenty which have been least exhausted since the previous time of charging) become fully charged and are thrown out of circuit, and the line "short-circuited" around them. This will slightly increase the charging current, owing to the decrease of resistance in the line, and one or more new batteries will be thrown into the circuit, until increase of current is checked as before. Thus, the whole hundred batteries will in time become charged, an automatic current regulator at the dynamo-machine preventing undue increase of current when the last twenty batteries are one after another thrown out of circuit. When the last twenty batteries on the line begin to cut out, which may be known by the action of the current regulator at the charging machine, another line of discharged or partially discharged batteries may be switched into the circuit; and when it is deemed that the remaining batteries of the first line have finished charging, this line may be switched out of circuit. Thus it will be seen that one charging machine may be made to charge an indefinite number of secondary batteries, the number depending only on the initial capacity of the machine, the length of time it is run, and the amount of charge used from the batteries. It will also be seen that the various batteries of an extended system may be used little or much, discharging a small or large current continuously, or at irregular intervals, while the operation of re-charging is under perfect and automatic control, and no current energy is wasted in overcharging any battery.

In the drawings, Fig. 15 illustrates one convenient form of apparatus embodying the invention. Fig. 16 shows a further development of Fig. 15, wherein both ends of the battery are disconnected from the charging circuit when the battery becomes charged or the charging current stops.

Fig. 17 shows an addition to the devices illustrated in Fig. 15, whereby a battery is disconnected from its working or discharging circuit, while the charging current is acting in the charging circuit.

Fig. 18 represents a system of secondary batteries, all charged from one line, each battery being provided with a current manipulator.

Fig. 19 shows a combination or compound arrangement of the magnets O and R of Fig. 15.

In Fig. 15, A represents a current generator, which may consist of a dynamo or magneto-electric machine or other apparatus capable of furnishing a suitable current. B is a secondary battery. C is an electro-magnet, located in the circuit  $a, a^1, a^2, a^3, a^4$ , connecting the generator and battery. D represents a number of electric lamps, electric motors, or other electro-receptive devices. E is a lever, pivoted at  $b$ . This lever may be provided with an adjustable weight  $d$  if desired. The free end of the lever E carries a contact point  $e$ , which is connected by a flexible conductor, or otherwise, with the charging line  $a$ . G is another lever, pivoted at  $l$ , and provided with an armature  $c$ , facing the pole or poles of the magnet C. This lever may be of iron, and the armature  $c$  dispensed with. The lever G may be provided with an adjustable weight  $m$  if desired.

$n$  is an adjustable stop, limiting the downward motion of the lever G.

By means of an arm  $o$  attached to the lever E, and which engages with the lever G after the latter has commenced to rise, in obedience to the attraction of the magnet C, the lever E is also raised.

I is a lever, pivoted at  $p$ , and connected by catches  $q$  (or an equivalent link) with the lever E, in such a manner that I is held up by E when the latter rises, while E may fall independently of I.

The lever I carries contact points  $f, i$ , which are insulated from each other. The lever I also carries a counterweight  $r$  sufficient to raise the other end of the lever carrying the contacts. The contact point  $f$  is flexibly connected with the line  $a^1$ ; and the double contact piece  $i$  is flexibly connected with one end of a resistance L, the other end of which is connected with the line  $a^2$ . This resistance may be made adjustable if desired.  $g$  is a stationary contact piece connected with the line  $a^2$ . This contact piece forms a stop to the upward motion of the lever I, and ultimately to the levers E and G, through the intervention of the catches  $q$  and arm  $o$ .  $h$  is another stationary contact piece directly connected with the line  $a^3$  by a conductor F. This contact piece forms a stop to the downward movement of the lever I, and also to that of the lever E, through the intervention of the double contact piece  $i$ .

O is a small magnet located in the charging line  $a, a^1$ . It is provided with an armature attached to a lever P, which is pivoted at  $s$ . The whole lever may be of iron, and the separate armature dispensed with. When P is drawn up by the magnet O, it makes contact with a stop  $t$ ; and when P falls, it is arrested by a stop  $u$ .

R is a magnet of high resistance, arranged as a shunt around the whole or a part of the battery B.

*Improvements in Secondary Batteries and Magazines of Electricity.*

B by means of the conductor  $v$ , lever P, stop  $t$ , conductor  $v v^1$ , and conductors  $a^3 v^2$ . The magnet R is provided with an armature lever S, pivoted at  $w$ . When the lever S is raised by the magnet R, it makes contact with a stop  $x$  (which may be made adjustable), which stop is connected with the line  $a^4$ .  $y$  is an adjustable stop, limiting the fall of the lever S.

The diagram just explained shows the various movable parts of the apparatus in the positions which they occupy while the generator A is charging the battery B. The current passes from the generator through the line  $a$ , magnet O, line  $a^1$ , contacts  $f g$ , line  $a^2$ , battery B, line  $a^3$ , magnet C, line  $a^4$ , and through any other apparatus there may be in the working circuit, back to the generator. The magnets O and C, being energized by the current, will retain the armatures in the positions shown.

While the battery B is charging, the difference of potential between its ends, or between any two points of the battery, remains nearly constant; but when the battery becomes fully charged, free gases are evolved from its elements, and the difference of electrical potential between any two parts of the battery at once increases materially. The number of elements of the battery B working the shunt-magnet R, and the distance of the armature S from the poles of the said magnet, are so adjusted that while the battery B is being charged, the magnet R will not be sufficiently energized to raise its armature S; while, at the same time, the adjustment is such that when the potential of the battery B rises at the completion of the process of charging, the increased current thereby shunted through the magnet R shall enable the latter to raise its armature.

This adjustment may also be effected through the agency of an adjustable weight (not shown) attached to the armature, or armature lever S. When the armature lever S rises and makes contact with the stop  $x$ , the magnet C will be "short-circuited," because the current from the line  $a^3$  may now pass through the lever S and stop  $x$  to line  $a^4$ . Thus, the magnet C is paralyzed sufficiently to allow the lever G to drop. This in turn allows the lever E to fall, and the contact point  $e$  to make contact with the conductor  $i i$ . Thus, the whole or a part of the current from the line  $a^1$  is shunted from the battery B through the resistance L.

The continued fall of the lever E, carrying with it the lever I, next breaks contact between the points  $f$  and  $g$ , and thus disconnects the battery B from the line  $a^1$ , and leaves the whole current from the latter in the resistance L. Finally, the contact piece  $i i$  makes contact with the piece  $h$ , thus "short-circuiting" the resistance L through the conductor F. This completes the operation of disconnecting the battery from the charging line, and "short-circuiting" the latter around the battery.

When a secondary battery discharges its current through a resistance sufficient to prevent a too rapid discharge, the electro-motive force of the battery remains nearly constant until its charge is nearly exhausted, after which the electro-motive force falls rapidly. Hence, by suitably adjusting the minimum distance of the armature S from its magnet, by means of the adjustable contact stop  $x$ , the armature S will fall when the electro-motive force of the battery B is reduced toward the close of the process of discharging. This will allow the magnet C to be energized if current is acting in the line  $a a^1$ , &c., and the lever G will be raised, and with it the levers E and I, thus throwing the battery B into the charging circuit.

If current is not acting in the circuit  $a a^1$ , &c., then the magnet C will still be left ready to act when the charging current again starts. But there are many objections to letting the battery B become nearly or quite discharged before re-charging, one of which is, that should the battery become exhausted while the line  $a a^1$ , &c., is not supplied with current, the battery will for the time being become useless. To avoid these difficulties I use the magnet O, through the agency of which, when energized by the charging current, the shunt circuit through the magnet R is established and maintained. But when the charging current stops, the armature lever P falls, the shunt circuit through R is opened, the armature lever S falls, and the "short circuit" around the magnet C is opened, leaving the latter ready to act when the charging current again starts; and all of this irrespective of any particular condition of the battery B. Again, the opening of the shunt circuit while the charging circuit is not acting, prevents any unnecessary waste of current through the shunt.

Let us now follow the operations which take place when the charging current starts, and the levers G, E, and I are at their lowest points. Matters have been so adjusted by means of the adjustable weight  $m$ , or the stop  $n$ , or both, that the lever G will not respond to the attraction of the magnet C until the charging current which excites the magnet has reached a certain strength, which is approximately its normal strength. Before this point is reached, however, the current may have been for some time charging other batteries, as hereinbefore explained. When the proper current strength is reached, the lever G rises, and presently engages the arm  $o$  attached to the lever E. By this time the armature  $c$  has approached nearer to its magnet, whose attraction has thus become sufficient to carry upward not only the lever G, but also the lever E, which is finally stopped by the contacts  $f g$  coming together. It will be noticed that the weight of the lever E is available to maintain a good contact between the points  $e i$ ,  $i h$ , until the instant of their positive separation. The reason for employing the independent lever G is now apparent. If the magnet C were made to act directly on the lever E, then the contacts  $e i$ ,  $i h$ , might, for long periods, be almost entirely relieved from the weight of the lever, whereby these contacts would be liable to destruction by burning.

When the lever E begins to rise, the contact-end of the lever I follows, owing to the counter-weight  $r$  as before specified. Thus, the contact  $e i$  is preserved, while the contacts  $i h$  are opened, which operation throws the resistance L into the charging circuit. Immediately thereafter, the contact points  $f g$  come together, arresting further movement of the lever I, and throwing the battery B into the charging circuit. The lever E continuing to move upward separates the contact points  $e i$ , and opens the resistance L, thus throwing all of the charging current into the battery B. Finally, upward movement of the lever E is arrested by the catches  $q$ , and the strong attraction of the magnet C for its armature is then exerted in maintaining a good contact between the points  $f$  and  $g$ , through which all of the charging current now passes.

In Fig. 16, the lever F, replacing the conductor F of Fig. 15, is pivoted at 1, and at one end carries the contact point  $h$ , and at the other end the contact point 2, which is flexibly connected with the line  $a^3$ . The lever F electrically connects  $h$  and 2. 3 is another contact, which, in conjunction with the contact

*Improvements in Secondary Batteries and Magazines of Electricity.*

2, connects the battery B with the line  $a^3$ . The lever F is weighted at 4 to insure contact between 2 and 3 when contacts  $h$  and  $i$  are separated. By means of this mechanism, both ends of the battery are disconnected from the charging circuit when the lever I falls, because the contacts 2 and 3, as well as  $f$  and  $g$ , are thereby separated.

In Fig. 17, the circuit from the battery B to the electro-receptive devices D is broken at two points, by the separation of the pairs of contact pieces 5-6, 7-8. The contacts 6 and 8 are attached to a block 9, and are insulated from each other, but are flexibly connected with the ends of the battery, as shown.

The contact pieces 5 and 7 are connected respectively with the two conductors leading to the electro-receptive devices D. The block 9 is connected by a link 10 with the free end of the armature lever P. When current is active in the charging line  $a a' a^2$ , &c., the magnet O is excited, and the armature P is raised, as explained in connection with Fig. 15. This, by means of the link 10, raises the block 9, and separates the contacts 5-6 and 7-8, thus disconnecting the electro-receptive devices D from the battery B, and from the charging circuit  $a^2 a^3$ . When the charging current stops, the magnet O drops its armature, the contacts 5-6 and 7-8 come together, and the electro-receptive devices B are connected with the battery.

The object of the device shown in Fig. 17 is to insulate the electro-receptive devices from the charging circuit when the working current is acting therein, and need be used only when such insulation becomes desirable, as, for instance, when a very large number of batteries are charged in one line by means of a current of very high electro-motive force. In such a case, there might be danger of the current "grounding" at two points in the circuit through defective insulation between the electro-receptive devices, and the various earth connections which are present in all buildings.

I prefer to make the contact points or pieces,  $e f g h$  &c., of carbon, such as is used in electric arc lighting.

Fig. 18 of the drawings illustrates a system wherein a current generator A, charging circuit or line  $a a$ , automatic current-controlling devices K, secondary batteries B, and electro-receptive devices D, are associated and combined, as has been hereinbefore described.

Fig. 19 shows a combination or compound arrangement of the magnets O and R (Fig. 15), wherein the helix of the magnet O is combined with that of the magnet R, the core of the latter being common to both helices. The electrical connections are so made that the main or charging current and the shunt current circulate in the same direction around the common core, and thereby act jointly in magnetizing the latter and attracting the armature lever S. The main current remaining constant, increase of current in the shunt circuit, due to rise of potential in the battery at the completion of its charge, will enable the magnet to raise its armature and produce the results already described in connection with Fig. 15. When, however, the charging current stops, the magnet R will be so weakened as to drop its armature, the same as when the shunt circuit was opened by the fall of the armature P in Fig. 15.

## DIVISION I.

"Division I" of this invention also relates to secondary batteries or apparatus for the storage of electrical energy, and it consists in devices hereinafter described, or their equivalents, for automatically measuring, indicating, or recording the amount of electrical energy spent in charging such batteries, while the charging current may be applied at irregular intervals and for irregular lengths of time.

This division of the invention is especially applicable to a system including several secondary batteries charged at intervals, wherein the several batteries are liable to be utilized or discharged to different extents from time to time, or continuously.

In carrying out this part of the invention, I provide each battery of a system with an automatic mechanism for manipulating the charging current, such as described in division H, so constructed, arranged, and electrically connected, that when a battery becomes fully charged, the charging current will be shunted away from the battery into another channel or into another battery to be charged. With this automatic current-manipulator I combine a time-measuring device in such a manner that while the charging current is acting to charge the battery, the length of time it so acts will be recorded; but when the battery becomes fully charged, or the charging current stops, the time-recording mechanism stops recording, or stops entirely. Now, since the strength of the charging current may readily be known, and may at all times be approximately constant, we have all the data necessary to determine the amount of electrical energy spent in charging each battery of a system of many batteries during any convenient length of time between observations of the recording apparatus—say one month.

Again, the amount of energy required to charge a secondary battery is an accurate measure of (although in excess of) the amount of energy drawn from the battery since the previous time of charging.

This draught of energy from the battery between, or between and during, the times of charging may obviously be little or much of the total capacity of the battery, and may be made rapidly or slowly, continuously or intermittently, according to the purposes for which the discharge is utilized.

As a unit of electrical energy used from a secondary battery (as indicated by the energy spent in charging it) I propose a current of one ampere, of one volt electro-motive force, acting for one hour. The electro-motive force of one cell of a secondary battery of lead elements is rather more than two volts. The charging current must be of higher electro-motive force than this, while the discharging current is of somewhat less electro-motive force, and is, under ordinary conditions of discharge, approximately two volts. Hence by multiplying together twice the number of cells of a battery, the strength of the charging current in amperes, and the number of hours it has acted, we arrive at the number of arbitrary units of electrical energy used from the battery.

In constructing the apparatus, I may employ any known time-measuring device, so arranged as to record time only when the charging current is acting in a battery. To this end, the time-measuring device may stop when the charging current in the battery stops, or it may continue to run while the recording mechanism only is stopped. Again, the time-measuring mechanism (such for instance, as a common clock movement) may be actuated by a spring or weight, and allowed to run only while the charging current is acting in the battery; or it may be actuated by the said charging current through the intervention

*Improvements in Secondary Batteries and Magazines of Electricity.*

intervention of a magnet or other suitable device, which will thus drive the clock only while the battery is being charged. The clock, in either case, is provided with a series of dials, whereby its record of hours may be carried to any suitable number.

Although I shall describe a simple marine clock-movement as the time-measuring device, I do not in any manner limit myself to this, as any known sort of time-measuring mechanism may be employed without in any manner departing from the spirit of the invention.

In the drawings, Fig. 20 illustrates an automatic current-manipulator for secondary-battery charging, combined with a time-recording apparatus.

Fig. 21 shows the time-recording apparatus actuated by the charging current,

In Fig. 20 is shown an automatic current-manipulator for secondary battery charging, so constructed, arranged, and electrically connected, that while the secondary battery B in connection therewith is receiving the charging current, the lever E will be raised and retained by the magnet C in the position shown; but when the battery B becomes fully charged, or when the charging current in the main or charging circuit stops, the lever E will fall a certain distance. A is a marine clock-movement provided, with a series of dials, registering the number of hours the movement is allowed to run. The spring which actuates the clock-movement is manually wound from time to time as may be necessary. D is the balance of the movement A. F is a wire or other flexible arm attached to the lever E, and is so adjusted that when the lever is held in the raised position shown, that is, while the battery B is charging, the wire F will be free from the balance-wheel D, and the latter will vibrate in obedience to the impulse given by the spring of the clock-movement. This adjustment is also such that when the lever E falls, which will happen when the battery B becomes fully charged, or when the charging current stops, the wire F will engage the balance D, and stop its movement, and thereby arrest the registration of time.

When the lever E again rises, the wire F will not only free itself from the balance D, but will give the latter an impulse sufficient to insure its starting.

In Fig. 21, H is a ratchet-wheel at the beginning of a clock-train (not shown) similar to that shown at A in Fig. 20. The revolution of this ratchet-wheel actuates the train, which is not provided with other actuating mechanism.

I is a pawl acting to rotate the wheel H, and attached to the free end of a stiff spring K, carried by the lever E.

When the lever E falls, the pawl assumes the position shown; and when the lever rises, the spring K is flexed as shown, and gives impulse to the ratchet H, whereby the clock-train thereto attached is actuated, and time recorded. The spring K continues to drive the clock until it has, owing to the partial revolution of the ratchet H, assumed the position shown by the dotted lines. But before this point is reached, the battery B will have become charged, the lever E will have fallen, and the registration of time will be stopped.

What I claim is:—

- First—An automatic current-manipulator for secondary-battery charging, so arranged, constructed, and electrically connected, that when the charging current stops or becomes reduced, the battery will be thrown out of the charging circuit, and will again be brought into the said circuit when the current in the latter is re-established, substantially as set forth in "Divisions G and H."
- Second—An automatic current-manipulator for secondary-battery charging, so constructed, arranged, and electrically connected, that when the charging current stops or becomes reduced, the battery will be thrown out of the charging circuit, and the latter will be closed around the said battery, substantially as set forth in "Divisions G and H."
- Third—In an automatic apparatus for charging a secondary battery, the combination with the current-generator of a main line or charging circuit, a magnet located in the main line, and an armature or lever, actuated by the said magnet and operating to throw the said battery into the said charging circuit, substantially as set forth in "Divisions G and H."
- Fourth—In an automatic apparatus for charging a secondary battery, the combination with a current-generator of a main line or charging circuit, a magnet located in the main line, and mechanism actuated by the said magnet and operating to throw the said battery into the said charging circuit, substantially as set forth in "Divisions G and H."
- Fifth—In an automatic apparatus for charging a secondary battery, the combination with a current-generator of a main line or charging circuit, and a magnet located in the main line and energized by the current therein, and adapted by releasing its armature or core when the current in the charging circuit stops or becomes sufficiently reduced to throw the said battery out of the said charging circuit, and to close the latter around the battery, substantially as set forth in "Divisions G and H."
- Sixth—In an automatic current-manipulator for secondary-battery charging, a resistance G, substantially as set forth in "Division G."
- Seventh—A system consisting of a suitable current-generating apparatus, a main line or charging circuit energized by said current-generating apparatus, two or more secondary batteries included within said charging circuit, and automatic apparatus associated with said secondary batteries, and constructed to be actuated by the current in the charging circuit, said apparatus operating to automatically throw said batteries out of the charging circuit, and to close said charging circuit around said batteries whenever the charging current ceases or becomes sufficiently weakened, substantially as set forth in "Divisions G and H."
- Eighth—A system consisting of a suitable current-generating apparatus, a main line or charging circuit energized by said current generator, two or more secondary batteries included within said charging circuit, and automatic apparatus associated with said secondary batteries, and constructed to be actuated by the current in the charging circuit, said apparatus operating to automatically throw said batteries out of the charging circuit when the charging current ceases or becomes sufficiently weakened, and to reinstate them in the charging circuit when the charging current is re-established, substantially as set forth in "Divisions G and H."
- Ninth—An automatic current-manipulator for secondary-battery charging, so constructed, arranged,

*Improvements in Secondary Batteries and Magazines of Electricity.*

- arranged, and adjusted, that when the charging current has approximately reached its normal strength (and not until then), the secondary battery in connection therewith will be thrown into the charging circuit, substantially as set forth in "Division H."
- Tenth—In an automatic current-manipulator for secondary-battery charging, an intermediate lever G, or its mechanical equivalent, substantially as set forth in "Division H."
- Eleventh—In an automatic current-manipulator for secondary-battery charging, intermediate mechanism, operating between a working magnet C and the current-switching mechanism, whereby the latter is not affected by the magnet C until said magnet has become sufficiently energized to properly operate the said current-switching mechanism, substantially as set forth in "Division H."
- Twelfth—In an automatic current-manipulator for secondary-battery charging, a resistance L, substantially as set forth in "Division H."
- Thirteenth—An automatic current-manipulator for secondary-battery charging, so constructed, arranged, and adjusted as to operate to switch the said battery out of the charging circuit when the electrical potential of said battery shall have reached a predetermined maximum, substantially as set forth in "Division H."
- Fourteenth—An automatic current-manipulator for secondary-battery charging, wherein the rise of electrical potential of the battery attending the completion of its charge is the initial agency employed to actuate mechanism for switching said battery out of the charging circuit, substantially as set forth in "Division H."
- Fifteenth—In an automatic current-manipulator for secondary-battery charging, a shunt circuit,  $v v^1 v^2$ , substantially as set forth in "Division H."
- Sixteenth—In an automatic current-manipulator for secondary-battery charging, a shunt circuit, and a magnet included therein, and energized by the current of said shunt circuit, substantially as set forth in "Division H."
- Seventeenth—In an automatic current-manipulator for secondary-battery charging, a shunt circuit, a magnet included therein and energized by the current of said shunt circuit, and mechanism associated with, and controlled by, said magnet, for performing the switching functions of said manipulator, substantially as set forth in "Division H."
- Eighteenth—An automatic current-manipulator for secondary-battery charging, wherein the fall of electrical potential of the battery attending the near exhaustion of its charge is the initial agency employed to actuate mechanism for switching said battery into the charging circuit, substantially as set forth in "Division H."
- Nineteenth—The shunt circuit  $v v^1 v^2$ , in combination with mechanism for breaking or open-circuiting the said shunt when the charging current stops, substantially as set forth in "Division H."
- Twentieth—In an automatic current-manipulator for secondary-battery charging, a main or working magnet located in the main or charging circuit, and provided with suitable mechanism for short-circuiting or shunting the charging current away from said magnet when the charging of the battery or batteries with which it is associated is sufficiently advanced, substantially as set forth in "Division H."
- Twenty-first—The combination with an automatic current-manipulator for secondary-battery charging, and with the discharging circuit of the secondary battery associated therewith, of a device constructed and arranged to disconnect or separate said discharging circuit from the said battery while the charging current is acting in the charging circuit, substantially as set forth in "Division H."
- Twenty-second—The combination with an automatic current-manipulator for secondary-battery charging, and with the discharging circuit of the secondary battery associated therewith, of a magnet located in the charging circuit, and energized by the current therein, and adapted, when thus energized, to disconnect and separate the said discharging circuit from the said secondary battery, substantially as set forth in "Division H."
- Twenty-third—A system including a current-generating apparatus, a main or charging circuit connected therewith, two or more secondary batteries located upon said charging circuit, and an automatic current-manipulating apparatus constructed, arranged, and adjusted to automatically switch a battery out of the charging circuit when it is sufficiently charged, through the initial agency of the rise of potential of said battery which attends the completion of its charge, substantially as set forth in "Division H."
- Twenty-fourth—A system including a current-generator, a main line or charging circuit connected therewith, two or more secondary batteries located upon said charging circuit, and an automatic current-manipulator associated with each of said batteries, said current-manipulating apparatus constructed, arranged, and adjusted to automatically switch a battery into the charging circuit when sufficiently discharged, through the initial agency of the fall of potential of said battery which attends the near exhaustion of its charge, substantially as set forth in "Division H."
- Twenty-fifth—A system including a current-generating apparatus, a main line or charging circuit connected therewith, two or more secondary batteries located upon said charging circuit, and an automatic current-manipulator associated with each of said batteries, said current-manipulating apparatus constructed, arranged, and adjusted to automatically switch a battery out of the charging circuit, whenever its electrical potential shall have reached a predetermined maximum.
- Twenty-sixth—A system including a current-generating apparatus, a main line or charging circuit connected therewith, two or more secondary-batteries located upon said charging circuit, and an automatic current-manipulator associated with each of said batteries, said current-manipulator so connected, arranged, and adjusted that when the charging current has approximately reached its normal strength (and not before), the battery with which said current-manipulator is associated will be thrown into the charging circuit, substantially as set forth in "Division H."
- Twenty-

*Improvements in Secondary Batteries and Magazines of Electricity.*

- Twenty-seventh—A system including a current-generating apparatus, a main line or charging circuit connected therewith, two or more secondary batteries located upon said charging circuit, each battery provided with an automatic current-manipulator and a discharging circuit, and mechanism for disconnecting and separating each discharging circuit from its battery, all so constructed, combined, arranged, and electrically connected, that when the charging current is acting in the charging circuit, the discharging circuit of each battery will be disconnected and separated therefrom, substantially as set forth in "Division H."
- Twenty-eighth—A method of measuring and indicating the amount of current-energy stored by a secondary battery, said method consisting in automatically recording the length of time during which a current of known strength is acting in said battery, substantially as set forth in "Division I."
- Twenty-ninth—A method of indirectly metering the discharge from a secondary battery, said method consisting in automatically registering the amount of energy expended in charging the battery from time to time, substantially as set forth in "Division I."
- Thirtieth—A method of measuring or indicating the amount of current-energy received by a secondary battery, said method consisting in automatically operating a time-recording mechanism only during the time that a current of known strength is acting in said battery, substantially as set forth in "Division I."
- Thirty-first—The combination of a secondary battery in the charging circuit of an electric-current-generating apparatus, a time-recording device and mechanism, whereby the time-recording device operates only when the charging current is acting in said secondary battery, substantially as set forth in "Division I."
- Thirty-second—The combination with a secondary battery, and the apparatus for charging said battery, of a time-recording mechanism, and a device for giving a starting impulse to said time-recording mechanism, so as to insure its starting at the time when the charging current begins to act in said secondary battery, substantially as set forth in "Division I."
- Thirty-third—The combination with a secondary battery and its current-charging apparatus of a time-recording mechanism, and a device for preventing or stopping said time-recording mechanism from performing its recording function while the charging current is not acting in the secondary batteries, substantially as set forth in "Division I."
- Thirty-fourth—A system including an electric-current-generating apparatus, a main line or charging circuit connected therewith, two or more secondary batteries within said charging circuit, and an automatic contrivance associated with each secondary battery for recording the length of time that the charging current is acting in said battery, substantially as set forth in "Division I."

In witness whereof, I, the said Charles Francis Brush, have hereto set my hand and seal, this twenty-seventh day of September, one thousand eight hundred and eighty-two.

CHARLES FRANCIS BRUSH.

Witness,—LEVERELD L. LEZZETS.

This is the specification referred to in the annexed Letters of Registration granted to Charles Francis Brush, this twenty-seventh day of June, A.D. 1883

AUGUSTUS LOFTUS.

### REPORTS.

Sir,

Sydney, 13 January, 1883.

We do ourselves the honor to report, in reply to your blank cover communication of the 19th ultimo, No. 13,954, that the petition of Charles Francis Brush for the registration of "Improvements in Secondary Batteries or Magazines of Electricity, and in Apparatus connected therewith," combines under one heading two distinct matters; and, as such combination materially complicates both the examination and record of the specification, we recommend that Mr. C. F. Brush be requested to submit a distinct petition and specification, &c., for that portion of his said invention relating to the "Construction and composition of Secondary Batteries," included under claims 1 to 22, and a distinct petition, specification, &c., for the remaining portion, relating to "Automatic Current Manipulators and Apparatus," which includes claims Nos. 23 to 56.

We have, &c.,  
E. C. CRACKNELL,  
GOTHER K. MANN.

The Under Secretary of Justice.

Sir,

Sydney, 11 May, 1883.

We do ourselves the honor to report, in reply to your blank cover minute of the 5th instant, No. 5,623, that we are of opinion Letters of Registration for an Invention entitled "Improvements in Secondary Batteries and Magazines of Electricity," may now be granted in favour of Mr. Charles Francis Brush, in accordance with his revised specification, drawing, and claim.

We have, &c.,  
E. C. CRACKNELL,  
GOTHER K. MANN.

The Under Secretary of Justice.

[Drawings—one sheet.]

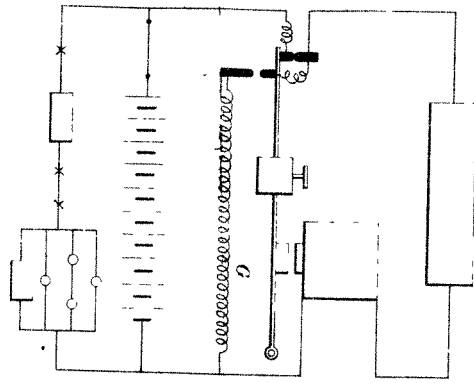


Fig. 10.

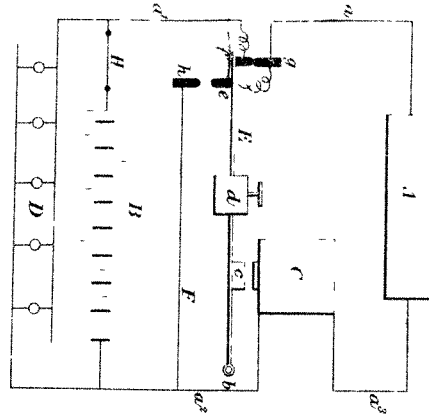


Fig. 9.

Fig. 11.

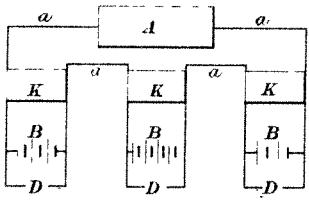


Fig. 12.

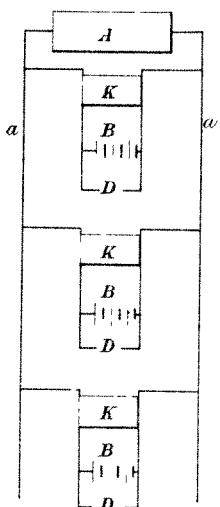


Fig. 13.

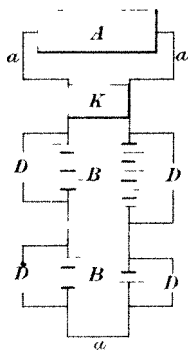


Fig. 14.

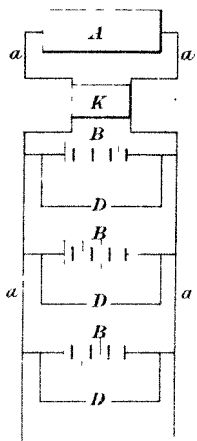


Fig. 15.

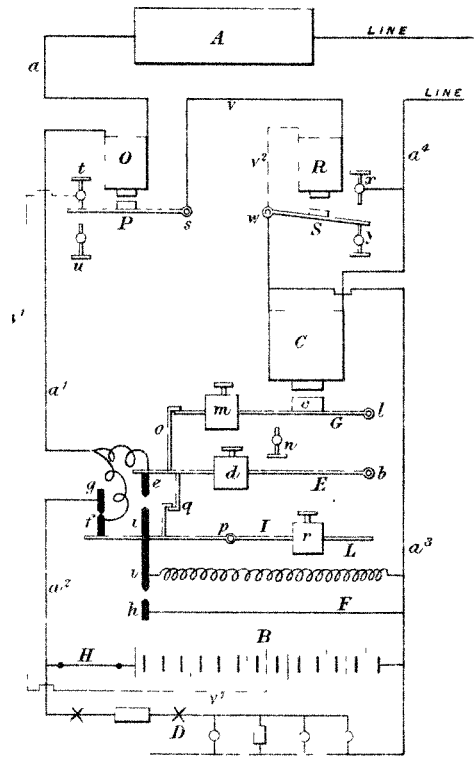


Fig. 16.

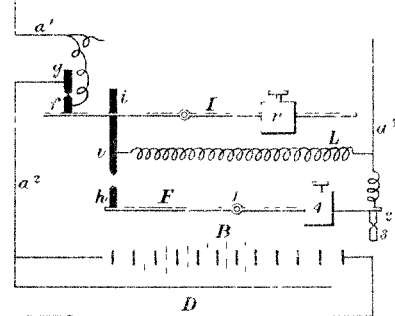


Fig. 19.

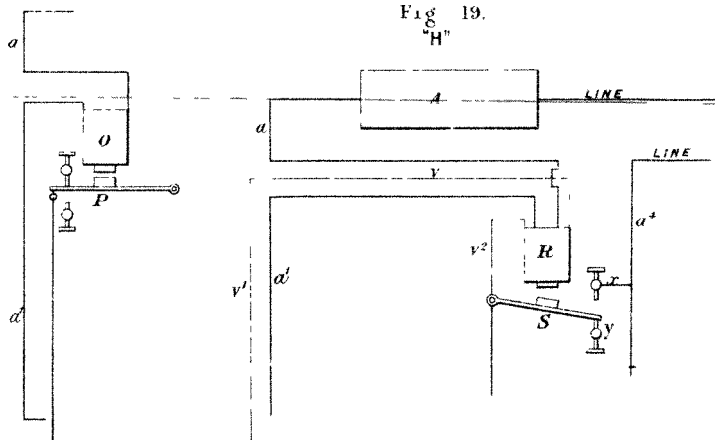


Fig. 17.

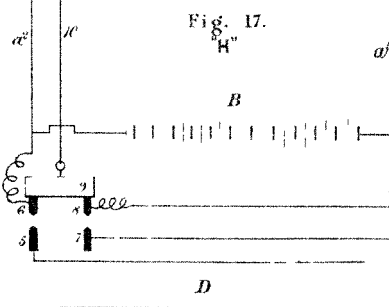


Fig. 18.

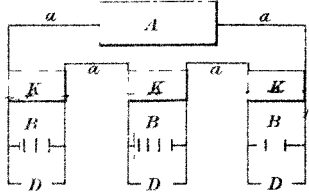


Fig. 20.

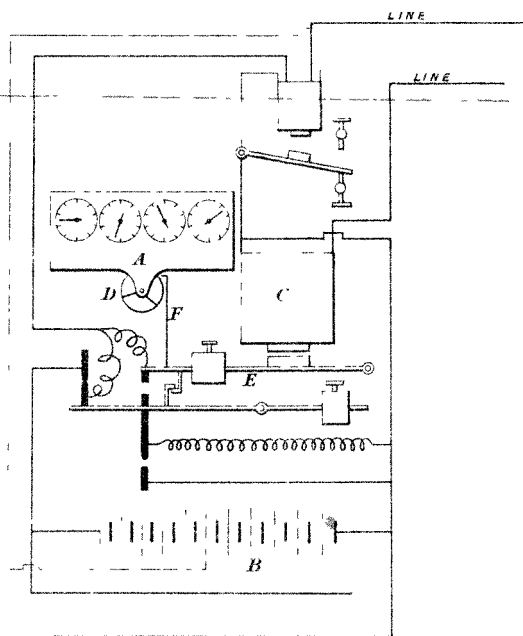
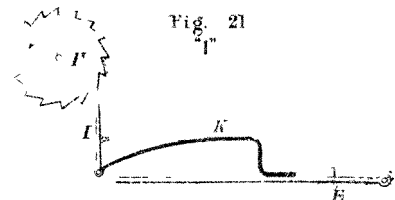


Fig. 21.



(Sig. 35.)

This is the Sheet of Drawings referred to in the annexed Letters of Registration granted to Charles Francis Brush, this twenty seventh day of June, A.D. 1883. Augustus Loftus.





A.D. 1883, 27th June. No. 1263.

AN IMPROVED CONTRIVANCE FOR PARING AND CORING FRUIT AND VEGETABLES.

LETTERS OF REGISTRATION to Joshua Barker Carter, for an invention entitled "An Improved Contrivance for Paring and Coring Fruit and Vegetables."

[Registered on the 28th day of June, 1883, in pursuance of the Act 16 Vic. No. 24.]

BY HIS EXCELLENCY THE RIGHT HONORABLE SIR AUGUSTUS WILLIAM FREDERICK SPENCER LOFTUS (commonly called LORD AUGUSTUS LOFTUS), Knight Grand Cross of the Most Honorable Order of the Bath, a Member of Her Majesty's Most Honorable Privy Council, Governor and Commander-in-Chief of the Colony of New South Wales and its Dependencies.

TO ALL TO WHOM THESE PRESENTS SHALL COME, greeting:

WHEREAS JOSHUA BARKER CARTER, of Barkly-street, St. Kilda, near Melbourne, in the Colony of Victoria, gentleman, hath by his Petition humbly represented to me that he is the author or designer of a certain invention or improvement in manufactures, that is to say, of an invention entitled "An Improved Contrivance for Paring and Coring Fruit and Vegetables," which is more particularly described in the specification with drawing, and which is hereunto annexed; and that he, the said Petitioner, hath deposited with the Honorable the Treasurer of the said Colony of New South Wales the sum of Twenty Pounds sterling, for defraying the expense of granting these Letters of Registration, as required by the Act of Council, sixteenth Victoria, number twenty-four; and hath humbly prayed that I would be pleased to grant Letters of Registration, whereby the exclusive enjoyment and advantage of the said invention or improvement might be secured to him for a period of fourteen years: And I, being willing to give encouragement to all inventions and improvements in the arts or manufactures which may be for the public good, and having received a report favourable to the prayer of the said Petition, from competent persons appointed by me to examine and consider the matters stated therein and to report thereon for my information, am pleased, with the advice of the Executive Council, and in exercise of the power and authority given to me by the said Act of Council, to grant, and do by these Letters of Registration grant, unto the said Joshua Barker Carter, his executors, administrators, and assigns, the exclusive enjoyment and advantage of the said invention or improvement, for and during the term of fourteen years from the date hereof; to have, hold, and exercise unto the said Joshua Barker Carter, his executors, administrators, and assigns, the exclusive enjoyment and advantage thereof, for and during and unto the full end and term of fourteen years from the date of these presents next and immediately ensuing, and fully to be complete and ended: Provided always, that if the said Joshua Barker Carter, shall not, within three days after the granting of these Letters of Registration, register the same in the proper office in the Supreme Court at Sydney, in the said Colony of New South Wales, then these Letters of Registration, and all advantages whatsoever hereby granted, shall cease and become void.

In witness hereof, I have hereunto set my sign manual, and have caused the present Letters of Registration to be sealed with the seal of the said Colony of New South Wales, at Government House, Sydney, in New South Wales, this twenty-seventh day of June, in the year of our Lord one thousand eight hundred and eighty-three.

[L.S.]

AUGUSTUS LOFTUS.



---

*An Improved Contrivance for Paring and Coring Fruit and Vegetables.*

---

SPECIFICATION of JOSHUA BARKER CARTER, of Barkly-street, St. Kilda, near Melbourne, in the Colony of Victoria, gentleman, for an invention entitled "An Improved Contrivance for Paring and Coring Fruit and Vegetables."

MY improved contrivance for paring and coring fruit and vegetables is a cylindrical instrument about six inches long, slightly tapering from hilt to point. The pointed or cutting end is sliced off somewhat in the shape of a quill pen, and the point itself is rounded off so as to form a nose rather than a point. Just about the place where the quill pen would be split, I make a narrow slot, say an inch and a quarter long, but not reaching to the nose. In this slot I set and fasten a scraper or knife in such a way as that its cutting edge projects outside the periphery of said contrivance—on the same principle as the cutter of a wood plane projects beyond its case—the object being to allow the knife to cut or scrape only a certain thickness from the fruit or vegetable to which it is to be applied. The nose is for cutting out small imperfections, such as the eyes of potatoes, and for cutting the way into an article so as to carry away a core. About the centre of the instrument I make a small slot, for the purpose of assisting to remove the core should it stick. In the sketch, A is what I call the hilt; B, the nose; C, the slot and scraper.

What I claim as my invention is—

The improved contrivance for paring and coring fruit and vegetables, substantially as herein described and explained.

In witness whereof, I, the said Joshua Barker Carter, have hereunto set my hand and seal this twenty-first day of March, one thousand eight hundred and eighty-three.

Witness—EDWD. WATERS,  
Melbourne, Patent Agent.

J. B. CARTER.

This is the specification with drawing referred to in the annexed Letters of Registration granted to Joshua Barker Carter, this twenty-seventh day of June, A.D. 1883.

AUGUSTUS LOFTUS.

---

REPORT.

---

Sir,

Sydney, 23 April, 1883.

In accordance with your B.C. minute of 6th instant on the application of Mr. J. B. Carter, of 29th March, for Letters of Registration for an invention entitled "Improved contrivance for paring and coring fruit and vegetables," we have to report that we see no reason why the request should not be complied with.

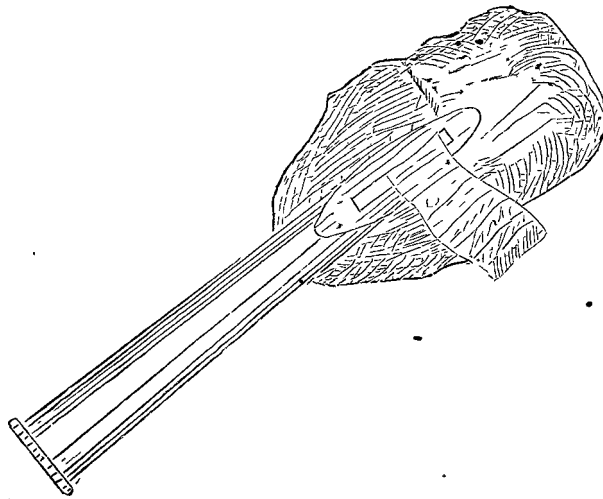
We have, &c.,  
JAMES BARNET.  
WILLIAM C. BENNETT.

The Under Secretary of Justice.

---

[Drawings—one sheet.]

JOSHUA BARKER CARTER'S PATENT.





A.D. 1883, 27th June. No. 1264.

AN IMPROVEMENT IN THE MANUFACTURE OF STEEL AND IRON,  
AND APPARATUS.

LETTERS OF REGISTRATION to Sidney Gilchrist Thomas, for an Improvement in the Manufacture of Steel and Iron, and the Apparatus used therefor.

[Registered on the 28th day of June, 1883, in pursuance of the Act 16 Vic. No. 24.]

BY HIS EXCELLENCY THE RIGHT HONORABLE SIR AUGUSTUS WILLIAM FREDERICK SPENCER LOFTUS in (commonly called LORD AUGUSTUS LOFTUS), Knight Grand Cross of the Most Honorable Order of the Bath, a Member of Her Majesty's Most Honorable Privy Council, Governor and Commander-in-Chief of the Colony of New South Wales and its Dependencies.

TO ALL TO WHOM THESE PRESENTS SHALL COME, greeting:

WHEREAS SIDNEY GILCHRIST THOMAS, of Palace Chambers, Westminster Bridge, London, in England, but temporarily residing at Melbourne, in the Colony of Victoria, metallurgist, hath by his Petition humbly represented to me that he is the author or designer of a certain invention or improvement in manufactures, that is to say, of an invention entitled "Improvement in the manufacture of Steel and Iron, and the Apparatus used therefor," which is more particularly described in the specification which is hereunto annexed; and that he, the said Petitioner, hath deposited with the Honorable the Treasurer of the said Colony of New South Wales the sum of Twenty Pounds sterling, for defraying the expense of granting these Letters of Registration, as required by the Act of Council, sixteenth Victoria, number twenty-four; and hath humbly prayed that I would be pleased to grant Letters of Registration, whereby the exclusive enjoyment and advantage of the said invention or improvement might be secured to him for a period of fourteen years: And I, being willing to give encouragement to all inventions and improvements in the arts or manufactures which may be for the public good, and having received a report favourable to the prayer of the said Petition, from competent persons appointed by me to examine and consider the matters stated therein and to report thereon for my information, am pleased, with the advice of the Executive Council, and in exercise of the power and authority given to me by the said Act of Council, to grant, and do by these Letters of Registration grant unto the said Sidney Gilchrist Thomas, his executors, administrators, and assigns, the exclusive enjoyment and advantage of the said invention or improvement, for and during the term of fourteen years from the date hereof; to have, hold, and exercise unto the said Sidney Gilchrist Thomas, his executors, administrators, and assigns, the exclusive enjoyment and advantage thereof, for and during and unto the full end and term of fourteen years from the date of these presents next and immediately ensuing, and fully to be complete and ended: Provided always, that if the said Sidney Gilchrist Thomas shall not, within three days after the granting of these Letters of Registration, register the same in the proper office in the Supreme Court, at Sydney, in the said Colony of New South Wales, then these Letters of Registration, and all advantages whatsoever hereby granted, shall cease and become void.

In witness whereof, I have hereunto set my sign manual, and have caused the present Letters of Registration to be sealed with the seal of the said Colony of New South Wales, at Government House, Sydney, in New South Wales, this twenty-seventh day of June, in the year of our Lord one thousand eight hundred and eighty-three.

[L.S.]

AUGUSTUS LOFTUS.

*Improvement in the Manufacture of Steel and Iron, and Apparatus used therefor.*

SPECIFICATION of SIDNEY GILCHRIST THOMAS, of Palace Chambers, Westminster Bridge, London, in England, but temporarily residing at Melbourne, in the Colony of Victoria, metallurgist, for an invention entitled "Improvements in the manufacture of Steel and Iron, and the Apparatus used therefor."

My improvements relate to the manufacture of steel and ingot-iron by the Bessemer and open hearth processes, and to the lining of the furnaces or apparatus used therein. By my invention steel or ingot-iron of good quality may be manufactured from crude or pig-iron containing considerable quantities of phosphorus and sulphur.

In carrying out my invention I do not use the silicious or fire-brick lining for the converter or furnace which is commonly employed, but I replace it by a basic lining which I produce by a novel process, which is as follows:—I take limestone, preferably of a kind which contains magnesia, in large proportions, and from 3 to 6 per cent. of silica alumina and oxide of iron, and calcine it a very intense white heat till it shrinks very greatly and becomes very hard and dense. This calcination I prefer to effect in a gas or coke cupola; the cupola I find most effective and economical is one supported on pillars about 5 feet from the ground, and with a drop bottom as well as side-discharging doors. It is lined with a basic lining such as is herein described, and should be not less than 20 feet in height between the charging-door and the bottom. I prefer that ordinary producer gas be admitted to the furnace through openings about 4 feet from the bottom of the cupola. The use of air-twyers passing through the gas-ports, so as to draw the gas into the cupola (on the injection principle) very rapidly and aid in its rapid combustion, is also very desirable; I prefer to have a second row of air-twyers immediately above the bottom of the cupola, the air from which becomes superheated before reaching the gas which it burns. The higher the pressure of the blast so as to ensure rapid combustion the better; it should not be less than one pound on the square inch. A similar cupola is used for calcining with coke, or a mixture of coke and gas can be used. In all cases a white heat must be obtained. The limestone can also be calcined in a kiln fired either with coal, or preferably with gas; but in all cases a down-draft kiln should be used, and the floor must be built of a lime and tar mixture, and a white heat must be maintained for some hours. The hard, dense material thus obtained can only be utilized as a furnace-lining after being mixed with tar. The method I prefer is to grind the shrunk dense lime into a coarse powder, mix it with about 5 per cent. of hot, boiled tar, or enough to give it coherence, and then ram the mass into iron moulds of the shape of the desired brick-form. I prefer the bricks should be of large size (say) 12 inches by 8 inches. The moulds when full are removed bodily into a stove kept at a low red heat, and kept there for from twenty-four to sixty hours, or till no more gas escapes. The moulds, which are made in several sections, held together by wedges or cotters, are then taken to pieces, and the bricks removed and used to line the converter or the hearth of the Siemens or other furnace it is desired to use. The bricks are united by a cement of finely-ground shrunk lime mixed with 15 per cent. of tar. Another mode of applying my basic lining is to ram a mixture of roughly-ground shrunk lime with about 10 per cent. of boiled tar with hot iron rammers between the plates of the converter or furnace, and an interior mould of suitable shape. I also sometimes make a mixture of a semi-fluid character with ground shrunk lime and about 15 per cent. of hot tar, and throw this in between the plates of the converter or furnace, and an interior iron mould of suitable shape, which latter is kept for some hours at a low red heat till the liquid mixture has set into a firm coherent lining.

Having thus described my invention, so far as it relates to the lining of the converter or furnace, I proceed to my improvements in the operation as conducted in the converter or furnace so lined. In conducting my improved Bessemer process, having lined the converter as above described, I throw into the vessel from five to seven times the weight of common pure burnt lime of the silicon and phosphorus together contained in the pig-iron to be converted. Thus, if 10 tons of pig-iron containing 1 per cent. of phosphorus and 2 per cent. of silicon is to be converted, I add to the converter about 36 cwt. of lime: I prefer the lime should be hot, but this is not absolutely necessary. I then run in the fluid pig-iron and blow it in the ordinary way, but I continue the operation for from one to five minutes after the drop of the flame, when the ordinary operation would be stopped, till in fact dense brown fumes and a white cloudy edge to the flame appear. I then take a sample, and after quenching it in water break it, to ascertain if the long acicular crystals indicating phosphorus are present. If they are not, the blow is finished. If the fracture shows phosphorus to be still present, the vessel is turned up, and blowing continued till a sample shows the right fracture. When this point is arrived at, I add to the blown metal from about 4 to 6 per cent. of its weight of ordinary pure hematite pig-iron in a molten state, that the silicon present in this addition may absorb any excess of oxygen in the metal; I then add spiegel or ferro-manganese, so as to give the required amount of carbon to the steel, and it is then ready for pouring into the moulds or ladle.

In applying my invention to the Siemens furnace, having lined the hearth with my basic lining as before described, I also support or suspend the roof of the furnace on iron girders independently of the hearth, so as to leave air space of an inch or more between the roof and the hearth. I prefer that the hearth should rest on a car or truck, as in the Pernot system. I also throw into the bed of the furnace before introducing the charge an amount of limestone equal to about six times the silicon and phosphorus together contained in the charge, or half this amount of burnt lime; I then add the pig and scrap, or pig and ore, as in ordinary Siemens or Siemens-Martin charge. The only difference in working the charge from the method observed in the ordinary process, is that I find it best to draw off the slag from time to time, and sometimes to add a little fresh lime, so as to keep a highly calcareous slag with less than 20 per cent. of silica, and I always find it best to add some ore. In both the Bessemer and Siemens operations it is useful to add a little fluor spar to render the slag more liquid; and in the Bessemer process it is preferable, when more than  $1\frac{1}{2}$  per cent. of phosphorus is present in the metal treated, not to add more than two-thirds of the lime to the converter before the metal, the rest being added after pouring off part of the slag, at the disappearance of the carbon lines, that is, about the period when the flame drops.

In the basic Siemens process, I also find it advantageous when there is much silicon in the pig to be treated, to first blow it in either a basic or acid converter (in the former case with suitable additions of lime, as above described), and then transfer the liquid purified metal to a basic Siemen's furnace where the scrap-iron, iron sponge, or ore is added and the necessary additions of spiegel made. The

*Improvement in the Manufacture of Steel and Iron, and Apparatus used therefor.*

The calcareous phosphoric slag from the above operations, when it contains over 13 per cent. of phosphoric acid, should be tipped while hot into water, by which means it is disintegrated, and then ground finely, the shots of iron removed; and it may then be used as a manure.

Having thus described my invention, and the best method I know of carrying it into effect, I claim,—

First—The herein-described process of manufacturing a durable basic furnace-lining from intensely fired and shrunk lime mixed with tar, substantially as herein described.

Second—The herein-described process of manufacturing Bessemer steel from impure or phosphoric pig-iron by treating it in a basic-lined converter with additions of lime, and by continuing the blow for from one to six minutes after the drop of the flame.

Third—The herein-described process of manufacturing Siemen's steel from impure or phosphoric pig-iron, by the use of a basic furnace, hearth, and basic additions, substantially as herein described.

In witness whereof, I, the said Sidney Gilchrist Thomas, have hereto set my hand and seal, this fourth day of April, one thousand eight hundred and eighty-three.

SIDNEY GILCHRIST THOMAS.

Witness—

U. S. BAYSTON,

Clerk to Edwd. Waters, Patent Agent, Melbourne.

This is the specification referred to in the annexed Letters of Registration granted to Sidney Gilchrist Thomas, this twenty-seventh day of June, A.D. 1883.

AUGUSTUS LOFTUS.

### REPORT.

Sir,

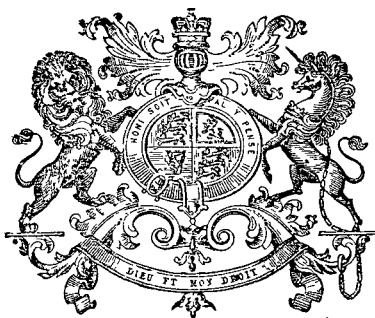
Sydney, 5 May, 1883.

In reference to your B.C. minute of the 7th ultimo, forwarding papers in connection with the Petition of Mr. Sidney Gilchrist Thomas for Letters of Registration for an invention entitled "Improvements in the manufacture of Steel and Iron, and the Apparatus used therefor," we have the honor to inform you that, having examined the specification accompanying the Petition, we recommend that Letters of Registration should be issued to Mr. Sydney Gilchrist Thomas for the invention referred to, as described in the specification appended thereto.

We have, &c.,

JOHN WHITTON.  
E. O. MORIARTY.

The Under Secretary of Justice.



A.D. 1883, 27th June. No. 1265.

**IMPROVEMENTS IN SECONDARY BATTERIES OR MAGAZINES OF ELECTRICITY.**

**LETTERS OF REGISTRATION** to Charles Francis Brush, for an invention entitled "Improvements in Secondary Batteries or Magazines of Electricity."

[Registered on the 28th day of June, 1883, in pursuance of the Act 16 Vic. No. 24.]

BY HIS EXCELLENCY THE RIGHT HONORABLE SIR AUGUSTUS WILLIAM FREDERICK SPENCER LOFTUS (commonly called LORD AUGUSTUS LOFTUS), Knight Grand Cross of the Most Honorable Order of the Bath, a Member of Her Majesty's Most Honorable Privy Council, Governor and Commander-in-Chief of the Colony of New South Wales and its Dependencies.

TO ALL TO WHOM THESE PRESENTS SHALL COME, greeting:

WHEREAS CHARLES FRANCIS BRUSH, of Cleveland, United States of America, electrical engineer, hath by his Petition humbly represented to me that he is the author or designer of a certain invention or improvement in manufactures, that is to say, of an invention entitled "Improvements in Secondary Batteries or Magazines of Electricity," which is more particularly described in the specification and the sheet of drawings which are hereunto annexed; and that he, the said Petitioner, hath deposited with the Honorable the Treasurer of the said Colony of New South Wales the sum of Twenty Pounds sterling, for defraying the expense of granting these Letters of Registration, as required by the Act of Council, sixteenth Victoria, number twenty-four; and hath humbly prayed that I would be pleased to grant Letters of Registration, whereby the exclusive enjoyment and advantage of the said invention or improvement might be secured to him for a period of fourteen years: And I, being willing to give encouragement to all inventions and improvements in the arts or manufactures which may be for the public good, and having received a report favourable to the prayer of the said Petition, from competent persons appointed by me to examine and consider the matters stated therein and to report thereon for my information, am pleased, with the advice of the Executive Council, and in exercise of the power and authority given to me by the said Act of Council, to grant, and do by these Letters of Registration grant unto the said Charles Francis Brush, his executors, administrators, and assigns, the exclusive enjoyment and advantage of the said invention or improvement, for and during the term of fourteen years from the date hereof; to have, hold, and exercise unto the said Charles Francis Brush, his executors, administrators, and assigns, the exclusive enjoyment and advantage thereof, for and during and unto the full end and term of fourteen years from the date of these presents next and immediately ensuing, and fully to be complete and ended: Provided always, that if the said Charles Francis Brush shall not, within three days after the granting of these Letters of Registration, register the same in the proper office in the Supreme Court, at Sydney, in the said Colony of New South Wales, then these Letters of Registration, and all advantages whatsoever hereby granted, shall cease and become void.

In witness whereof, I have hereunto set my sign manual, and have caused the present Letters of Registration to be sealed with the seal of the said Colony of New South Wales, at Government House, Sydney, in New South Wales, this twenty-seventh day of June, in the year of our Lord one thousand eight hundred and eighty-three.

[L.S.]

AUGUSTUS LOFTUS.

*Improvements in Secondary Batteries or Magazines of Electricity.*

SPECIFICATION of CHARLES FRANCIS BRUSH, of Cleveland, United States of America, electrical engineer, for an invention entitled "Improvements in Secondary Batteries or Magazines of Electricity."

THE invention relates to secondary batteries, or apparatus for the absorption of electric energy and subsequent exhibition of the same.

For the sake of convenience in describing and referring to the various embodiments of the invention that I shall herein set forth, I shall specify them separately and successively, and distinguish each alphabetically.

*Division A.*

"Division A" of the invention refers to a method or process of "forming" the plates or elements of a secondary battery—that is, of causing them to assume the best condition for the purpose to which they are applied.

The most common form of secondary battery consists of two sheets or plates of lead, placed near each other, but not in contact, and immersed in dilute sulphuric acid.

These sheets are often of large surface, in which case they are frequently rolled into a cylindrical spiral, care being taken that they do not touch each other, so as to effect economy of space, and to expose both sides of each sheet to its neighbour.

When an electric current is passed through such an apparatus, water is decomposed; hydrogen is occluded by, or combines with, one of the lead plates, while oxygen combines with the other plate, and forms a coating thereon of peroxide of lead. This oxide of lead, not being capable of combining with any acid, is not affected by the presence of the sulphuric acid employed.

Now, if the exciting current be removed, it will be found that the apparatus has become a powerful battery, giving a current in a direction opposite to that of the exciting one. But this current is of short duration, and will not long remain stored. Repeated or long continued charging of the apparatus increases its capacity, but the latter will always remain small. It has been found, however, that the capacity of the apparatus may be greatly increased by reversing the charge from time to time—frequently during the first few days, and more rarely afterwards.

This process may continue for several months, the apparatus continually improving, rapidly at first, more slowly later. This series of reversals of charge constitutes the customary method of "forming" the plates of a secondary battery.

I have carefully investigated the chemical and mechanical action involved in the above-indicated process, and have arrived at a satisfactory explanation of the results produced.

The formation of peroxide of lead on one of the plates continues indefinitely as long as the exciting current is maintained, becoming constantly slower as the metallic surface acquires an increasing protection against further action by the constantly increasing thickness of the coating of peroxide of lead thereon.

Peroxide of lead being a good conductor of electricity, the coating thereof above described becomes a part of the conducting plate or element of the battery, and free oxygen is evolved at the surface of the coating.

Now, if the exciting current be stopped, "local action," somewhat similar to that in galvanic batteries, and electrical in its nature, commences between the peroxide of lead and the backing or support of metallic lead with which it is in contact. By this "local action" the peroxide of lead is gradually reduced to a lower state of oxidation, while more of the metallic lead of the plate is oxidized by the oxygen thus made available.

The fresh lead thus oxidized doubtless acquires the same condition of oxidation that the original peroxide finally assumes. But the peroxide is never by this action reduced to the state of protoxide, as is proven by the colour of the coating, and the non-action on it of the ever present sulphuric acid.

When peroxide of lead is thus reduced to a state of lower oxidation, it becomes useless for the development of a secondary current until freshly charged or re-oxidized. Thus is explained, so far as the oxygen plate is concerned, the cause of the gradual loss of charge observed in lead secondary batteries.

Further, since the conducting power of peroxide of lead rapidly decreases as its oxygen is removed, the reason of the high electrical resistance of the oxidized plates after long standing uncharged is also explained. When such a plate as I have described—that is, one having gradually lost its original charge by local action—is re-charged by an electric current as at first, it will hold a larger charge than before; because all of the lower oxide of lead is now raised to the condition of peroxide, and thus more of the latter is present than at the previous time of charging. This explains why the oxygen plate of secondary batteries constantly increases in capacity, even though the exciting current be applied at long intervals.

Let us now consider what takes place at the opposite side of the secondary battery, that is the action on the lead plate where the hydrogen appears. Here the hydrogen is absorbed at the surface of the plate, being simply occluded, or more probably forming a definite but feeble chemical combination with the lead. If such a combination exists, it is a nearly or quite stable one, so far as "local action" is concerned, for experience shows that the capacity of the plate for the reception of hydrogen increases very slowly, if at all, when the plate is left charged a long time but without the action of the exciting current; even the continued action of the exciting current increases the capacity of the hydrogen plate very slowly indeed, as compared with the improvement of the oxygen plate during the same time.

The capacity of the hydrogen plate never becomes at all considerable when it is subjected to the above action alone. Hence, in practice, the oxygen plate soon acquires much greater capacity than the hydrogen plate; but this is of no advantage, since its usefulness is limited by that of the hydrogen plate. But, if now the charge of the two plates be reversed, by changing the direction of the exciting current, the former hydrogen plate will absorb oxygen freely as did the other plate at first, while the former oxygen plate will have its coating of oxide of lead reduced to the metallic state by the nascent hydrogen evolved upon it, and will thus be left with a corresponding coating of porous lead. This porous metal is now in a condition to absorb and retain an amount of available hydrogen about equivalent to the available oxygen which it before held.

Thus—

*Improvements in Secondary Batteries or Magazines of Electricity.*

Thus it will be seen that the simple act of reversing the charge of the two plates increases the capacity of the apparatus up to a point attained only by the oxygen plate before the reversal. Again, what is now the oxygen plate continues to improve, as in the first instance, while the hydrogen plate remains nearly or quite stationary in this respect.

Hence, after a time, a further increase of capacity in the apparatus may be effected by another reversal. This is explained the reason for the many reversals of charge customary in "forming" the plates.

When a previously excited secondary battery is discharged, the peroxide of lead is thereby reduced to a state of lower oxidation, as already explained in connection with the spontaneous loss of charge. Thus, what was at first a good conducting coat or envelope on the metal plate is now reduced to a poor conductor, as previously explained, while at the same time pure water is formed within the mass of lead-oxide by the combination of hydrogen with a portion of the oxygen of the peroxide of lead; and, since pure water is a very poor conductor of electricity, a further barrier to the passage of current between the sulphuric acid solution and the metallic plate within the envelope of lead-oxide is raised.

These two causes (lower oxidation and presence of pure water) account, so far as the oxygen plate is concerned, for the increase of resistance in secondary batteries during their discharge, and especially toward the end of the process.

In the case of the hydrogen plate, pure water is also formed by the union of oxygen with its hydrogen, whereby the necessary liquid conductor within the porous metal has its resistance largely increased.

The cause of the gradual spontaneous loss of charge, in case of the hydrogen plate of secondary batteries, is not the same as that already described in connection with the oxygen plate. The hydrogen in this case seems to be gradually dissolved and carried away from its plate by the dilute sulphuric acid, which then discharges it gradually into the atmosphere.

If in charging a hydrogen plate a chemical compound of lead and hydrogen is formed, as I have before suggested, this compound would appear to be gradually decomposed in the presence of the acid water, giving up its gas to the latter.

There are certain evils incident to the above-described process of "forming" the lead plates of secondary batteries, which attendant evils prevent the attainment of the best results, and limit the ultimate capacity of the apparatus to a comparatively small field of usefulness.

The coating of peroxide of lead which is formed on one of the plates necessarily occupies more space than did the metallic lead which it contains. The shell of oxide must, then, expand in forming. To accommodate this expansion, which evidently occurs in all directions, the structure of the deposit must be more or less broken up at numerous points, or else the lead plate itself must expand.

The occurrence of the latter action may readily be observed when the lead sheet is thin.

When, now, the direction of charge is reversed, by which operation the oxide of lead is reduced to the metallic state, the previously expanded mass shrinks.

Both the expansion and subsequent shrinkage may be illustrated by treating one side only of a sheet of lead, the other side being protected from action by varnish, or otherwise. When such a plate is oxidized the exposed side becomes convex; when the oxide is subsequently reduced, this side becomes concave.

During the process of reduction the shrinkage does not occur in all parts of the mass at once, as the reduction is not simultaneous in all parts at once, but is progressive. The converse of this is true when the reduced lead is again oxidized. Hence there is a disintegrating action in the changing mass itself, as well as between it and the solid plate behind it. This alternate expansion and contraction of the action and valuable portion of the lead plate does not lead to serious disturbance when it is allowed to occur only once, or a very small number of times. But if these changes are many times repeated, the coating peels off from the lead plates to a considerable extent, and thus becomes useless. This evil is especially noticeable in the case of thick deposits.

Again, every time the deposit of oxide of lead is reduced, a notable quantity of sulphate of lead is formed within the mass.

This inert and useless substance, when allowed thus to form, soon exercises a very deleterious influence, wasting in its formation the otherwise available oxide of lead, stopping the pores of the essentially porous mass, and tending to disintegrate the latter by occupying a much larger space than the oxide of lead from which it is formed.

The reduction of the oxide of lead is also attended with danger of separating the mass from its supporting lead plate, by the liberation of gas between the two, especially when the reducing current is of sufficient strength to effect the change at all rapidly.

The frequent reversal of charge is also expensive, in that much energy of charging current is wasted at each operation.

Further, it will be seen that the oxygen, which is the active though slow agent in improving the plates, acts not on both sides simultaneously, but on only one at a time.

The method or process of "forming" the plates or elements of secondary batteries, which constitutes the special subject of "Division A" of the invention, avoids or eliminates the above-enumerated evils almost entirely; whereby, with plates of any given size or form of construction, I produce ultimately, or within a given time, an apparatus of much greater capacity than was heretofore found possible.

The process consists in charging the plates which are ultimately to constitute the battery in such a manner that a coating of peroxide of lead of sufficient thickness is formed on both of them; these plates are then associated together in the usual manner, and an electric current passed through the apparatus in the manner customary in charging; whereby one of the plates remains unchanged, and constitutes the oxygen element of the battery, while the other has its charge reversed, and now constitutes the hydrogen element of the battery.

In the drawings, figs. 1 and 2 are diagrams illustrating the method of "forming" the elements of secondary batteries.

In fig. 1, *a b* are the lead plates, which are ultimately to form the secondary battery. They are both connected, as shown, to the oxygen-producing pole of a current generator, H.

*c* is a third plate, similar, or not, to the others, and connected to the hydrogen-producing pole of the generator H. All the plates are immersed in dilute sulphuric acid contained in the vessel I.

Fig. 1



---

*Improvements in Secondary Batteries or Magazines of Electricity.*

---

Fig. 2 shows the plates *a b* arranged for the reversal of the charge in *b*, the latter being now connected with the hydrogen-producing pole of the generator II.

This is also the arrangement for charging the battery for use after its plates are duly "formed."

Obviously, the arrangements shown in figs. 1 and 2 may be modified almost indefinitely, while producing the same result. Many plates *a b* may be charged at once, using only one plate *c*.

The vessel I may be of lead or copper, and constitute the plate *c*. The plate *c* may consist of one or more previously charged plates, *a* or *b*, which thus become reversed, and are then ready, without further treatment, to be paired with other charged plates, *a* or *b*, in the construction of secondary cells ready for use.

The plates *a b*, while acquiring their coating of lead peroxide, may for this purpose be charged continuously; or (and this is equally effective and more convenient) they may be charged at intervals only—short at first, which may be increased in length as the process progresses, thus allowing the "local action" between the peroxide of lead already formed and the metallic lead to continue the oxidizing process during the time the charging current is not acting.

Several months of continuous or intermittent charging is required when ordinary sheet lead alone is employed for the plates *a b*, in order to produce a satisfactory coating of peroxide of lead.

The process of reversing the charge of one of the plates *a b* need not occupy more than a few hours. It will be apparent that this process of "forming" possesses, among its many advantages, that of producing a given capacity (supposing such to be attainable by the old method) in the apparatus under treatment in a very much less time than would be required by the "forming" process commonly employed, in that both plates simultaneously, instead of one at a time, are acted upon by the oxygen, which is the active agent in improving or developing the plates.

Uncharged plates, *a b*, may be arranged at once as in fig. 2, and charged until plate *a* has become sufficiently coated; after which the direction of the charging current may be reversed, thus making a hydrogen plate of *a*.

If now the reversed charging action is continued until plate *b* has acquired a sufficient coating, we shall reach the same result as when both plates are simultaneously charged with oxygen and one afterwards reversed; but the process will have occupied twice the time.

This process of "forming" the plates of secondary batteries is applicable not only to the flat or plain plates ordinarily used, but equally so to corrugated, and to ribbed, honey-combed, perforated, slotted, or otherwise fashioned plates, such as will be hereafter described under other divisions of this specification; also especially to plain corrugated or otherwise fashioned plates, coated or filled with spongy or porous or reduced lead, as will also be specially described hereafter in this specification.

*Division B.*

"Division B" of this invention consists in providing the plates, or elements of secondary batteries, with a suitably thick coating of electrically deposited coherent metal previous to the process of "forming" the said plates or elements.

In preparing or coating plates or elements according to the present division of the invention, the coherent porous lead is deposited thereon by electrical action, in the manner customary in any ordinary process of electro-plating; the plates to be coated, first being made chemically clean, and the plating solution consisting of oxide of lead dissolved in a solution of a caustic alkali, or of an equivalent solution of lead. Any solution of lead may be used, provided it is such as to produce a coherent deposit of metal, and not a spongy or non-coherent deposit. The latter kind of deposit is always produced when the sulphate, chloride, acetate, nitrate, and some other salts of lead are reduced electrically, and possesses properties different from those of the coherent form of metal, being vastly inferior to the latter in efficiency as a material for secondary batteries.

The coherent metal may be deposited with greater or less rapidity as may be found most expedient or desirable in practice, the character of the deposit varying to some extent according to the rate and other circumstances of its formation.

Corrugated, ribbed, or cellular slotted or otherwise perforated plates are well adapted to receive and retain the coherent coating, and the corrugations or other spaces or cavities in the plates may be entirely filled with the deposit if desirable. When such plates are treated to a deposit of coherent lead in the manner customary in electro-plating, the interior of the cells or cavities or corrugations will receive a less heavy deposit than the more exposed portions. I avoid this difficulty by adopting the following method of working:—

The drawing fig. 3 is a diagram showing a simple method of lining or filling the grooves in ribbed or similar plates with the deposited metal. The plate *a*, being first thoroughly cleaned, has the grooves or cavities on one of its sides filled with protoxide or other suitable compound of lead, either dry or made into a paste with water or saline solution.

The plate is then placed horizontally, prepared side up, in a suitable vessel, I, containing a solution of caustic soda or potassa, or other alkali, when protoxide of lead is used in the grooves.

Any liquid may be used, provided it is capable of dissolving the lead compound, whatever it may be, in the grooves or corrugations of the plate *a*, and of depositing the metal, when electrolysed, in a coherent state. In the same solution, but not touching the plate *a*, is suspended or placed a lead or equivalent plate, *k*. Current from a suitable source, H, is then passed through the apparatus in the proper direction, until the lead oxide in the grooves or corrugations is exhausted, and its metal deposited on the sides and bottom of the grooves. More lead oxide may be added, if it is desired to increase the deposits. The solution may be heated, to hasten or facilitate the process, if found expedient. When one side of the plate is prepared, the other side may be treated in the same manner.

By this method a strong solution of lead is maintained within the grooves or corrugations, while other portions of the solution remain poor in metal, whereby a heavy deposit of metal is secured on the sides and bottom of the grooves.

If a grooved plate is simply suspended in a solution of lead-oxide and thus treated, the principal deposit of metal will occur on the exposed edge of the ribs, and comparatively little metal will be deposited within the grooves.

Plates

*Improvements in Secondary Batteries or Magazines of Electricity.*

Plates of other metals than lead may be employed to receive and support the deposited lead; thus, gold or platinum may be used, and in this case the oxygen element of the battery, if fully peroxidized, cannot lose its charge by the spontaneous "local action," described in "Division A."

Carbon, or even copper, may be used in the case of the hydrogen plate or element of the battery for receiving the deposited metal.

When lead or other plates coated or filled with deposited coherent lead are associated together in a secondary battery and charged, the reduced metal of one of the plates is peroxidized much faster than ordinary cast or rolled lead, but not nearly so fast as spongy or non-coherent lead; while the coherent lead of the other plate absorbs hydrogen more freely than cast or rolled lead, but not nearly so fast as the other plate of the battery absorbs available oxygen.

It becomes advisable, then, to resort to a "forming process," as described in Division A, and the improved process, as therein set forth, is preferable to any other.

*Division C.*

"Division C" of this invention relates to providing the plates or elements of secondary batteries with a suitably thick coating of porous metal, reduced from the oxide or any suitable compound thereof, through the agency of any suitable reducing gas or gases, and at a temperature insufficient to cause the reduced metal to assume a compact or fluid condition through fusion.

This feature of the invention may be applied, not only to plain plates, but also to corrugated, ribbed, cellular, perforated, or slotted, or otherwise fashioned plates or elements.

In preparing or coating plates according to "Division C" of the invention, the porous lead may be reduced thereon from the oxide of the metal by means of an atmosphere or current of carbonic oxide or hydrogen, at a temperature insufficient to fuse the reduced metal.

Either of the gases mentioned will do this readily, and they may be used pure or mixed together, or with any neutral gas, such as nitrogen. The plates having been made chemically clean, are placed in a horizontal position, and covered to a sufficient depth with lead oxide. This may be applied dry, or preferably in the form of a paste, with water, or with some liquid such as nitric acid, which partially dissolves the oxide, and when evaporated leaves the latter in a coherent compact condition. Solution of nitrate of lead may be employed directly to form the paste. The oxide of lead may be fused before use, if found desirable, and applied either as a coarse or fine powder, or mixture of both. A lead plate having been thickly sprinkled with coarsely pulverized lead-oxide may have the latter securely imbedded in its surface by means of a parallel flat plate of iron, applied with hydraulic pressure, or other means. When corrugated or ribbed plates are used, the corrugations or spaces between the ribs may be filled with the lead-oxide if found desirable. The lead-oxide may be fused, and poured in a thin layer over the plates, chilling thereon before fusion of the plates takes place, or the corrugations or grooves of the plates may be filled with the fused oxide. When plates other than lead are employed, such, for instance, as gold or platinum, they may be dipped into the fused oxide, and when withdrawn will retain a coating thereof.

Previous to the application of a coating of lead-oxide, the plates may receive a preliminary coating of oxide, by treatment with a current of electricity in a charging battery. This preliminary coating will assist in attaching the principal coating, and the subsequently reduced metal, firmly to the plate.

After the plates are coated with oxide they are packed, sufficiently separated from each other, in a suitable vessel or chamber, where they may be raised to a sufficiently high temperature, and exposed for a sufficient length of time to the action of a reducing gas.

In the drawings, fig. 4 is a diagram illustrating a convenient method of treating the plates to a stream of carbonic oxide mixed with nitrogen, and hydrogen if desired. Fig. 5 shows a cross-section of the apparatus in fig. 4 through the line  $x-y$ .

In fig. 4,  $L$  is a chamber of sheet iron, having a cross-section slightly wider than a plate to be treated, and considerably longer, as shown in fig. 5. The chamber is provided at the top with a chimney, and at the bottom with a grate supporting a thick layer of ignited charcoal or coke, all as shown.

$a, a$  are plates to be treated, coated on the upper side with oxide of lead, and supported at a sufficient distance from each other by ribs (not shown) attached to the sides of the chamber.

The plates are arranged so as to leave openings at alternate sides of the chamber as shown, in order to direct the current of gases from the fire across the faces of the plates.  $m$  is a plate of metal or slate, to properly direct the gases from the fire, and to protect the lead plates from the direct heat thereof.  $n$  is a similar plate, to confine and direct the gases over the top lead plate, and prevent too great radiation of heat therefrom. The operation of the apparatus is obvious.

Air, in passing upward through the thick bed of incandescent fuel, has its oxygen converted into carbonic oxide, and the hot carbonic oxide and nitrogen pass upward between the plates, thereby heating them, and ultimately reducing the oxide of lead to the metallic state. The gases finally escape at the chimney.

If steam is introduced with the air, hydrogen is also formed.

Obviously, many forms of apparatus other than the one shown may be employed to effect the reduction of the lead-oxide.

The coating of porous metal described, as applied to the plates of secondary batteries, possesses properties differing from those of either spongy lead or the electrically deposited coherent lead described in "Division B." It may be regarded as being intermediate in character between the two, but possessing many of the advantages of the latter, and being free from the disadvantages of the former.

Plates of other metals than lead may be used to receive and support the porous lead; thus, gold or platinum may be used, and, in this case, the oxygen element of the battery, if fully peroxidized, cannot lose its charge by the spontaneous "local action" described in "Division A." Carbon, or even copper, may be used in the case of the hydrogen plate, or element of the battery, for receiving the reduced metal.

As before indicated, the properties of the reduced porous lead are similar to those of the electrically-deposited coherent metal described in "Division B." Hence, the remarks there made in reference to the association together of prepared plates or elements, and to the process of "forming" them for use, will apply equally well here.

"Division

*Improvements in Secondary Batteries or Magazines of Electricity.**Division D.*

"Division D" of this invention consists in another construction of secondary battery elements, and, as this construction is more or less closely related to the various specific subjects of the foregoing Divisions of this specification, I refer the reader to said preceding Divisions, as far as may be necessary, for a full understanding of the present Division of the invention,

In this Division I shall describe a secondary battery element, wherein, before treatment by a "forming" process, either the entire body thereof, or only the coating or covering of a suitable core or body, consists of a mass composed of metallic lead and lead-oxide in an intimately mixed condition, pressed or united together into a compact and firmly coherent mass. In constructing this mass, I take metallic lead in a pulverized, granulated, precipitated, or other finely divided state, and allow the surface of the lead particles to become oxidized, either by exposure to the air, or by any suitable artificial oxidizing process or application.

Or, instead of employing the superficially oxidized particles of lead as above specified, I may take particles of metallic lead and oxide of lead, and effect a thorough mechanical mixture of the two.

In either of the above cases it will be seen that metallic lead and lead oxide are thoroughly intermingled. I now subject the mixture to heavy pressure, hydraulic or otherwise, whereby its particles are united and consolidated into a compact and firmly coherent mass.

The mass thus formed consists of metallic lead, having minute veins of oxide of lead everywhere ramifying and extending through it; and these veins of lead-oxide within and throughout the mass greatly facilitate the penetration of the electrical action in "forming" the plates for operative use in secondary batteries.

I do not limit myself to any particular temperature that the oxidized lead particles or the mixture of lead and lead-oxide particles must have when subjected to the pressure by which they are united together. Any temperature, short of the fusing point, may be employed that may be found desirable.

In constructing battery elements from the above-described mass in either of its forms, the particles can, if desired, be originally pressed in moulds that will give to the finished product the shape required for said elements; or it can be made into blocks, sheets, bars, strips, wires, or otherwise, and afterward be manipulated as may be desired to form or construct any style of element. I do not limit myself in the degree of fineness to which the particles of lead or oxide must be reduced, nor to any exact amount of pressure to be exerted in solidifying them into a mass, so long as said pressure is sufficient to unite them into a suitably compact and coherent body.

As already intimated, the above-described mass may be made to constitute the entire body of the battery element, or it may form the active coating or covering of any suitable supporting and electro-conducting core or body.

To form an element having a core or body coated with the mass described, I take a sheet or other suitable piece of lead, or of other substance suitable for the purpose, and, if necessary, roughen or score its surface, or pierce it with numerous perforations to insure a firm adhesion of the mass which is to constitute the active coating. I cover it with the finely divided superficially oxidized lead (or the mixture of metallic lead and lead-oxide particles), and apply heavy pressure. The result is that the finely divided particles are not only pressed into a firm and strongly coherent mass, but the mass is also firmly united to the supporting core or body. This core may be of lead, or it may consist of a non-oxidizable metal, such as gold or platinum, or any alloy of these metals with lead. Secondary battery elements, constructed according to this Division of the invention, are well adapted to be "formed" by the process specified in "Division A."

*Division E.*

"Division E" of my invention consists in and relates to a secondary battery plate or element of any form, consisting of a supporting core or body, composed of an alloy of lead and some non-oxidizable material (such as gold, platinum, an alloy of these metals, or other suitable substance), to which alloy core or body is in any effective way applied, connected, or attached, an active coating.

It is desirable, in a secondary battery, that the elements should present the greatest amount of active material, and have a minimum quantity of the idle or non-acting material, that merely serves as an electro-conducting support for the active portion of the element; and one of the objects sought, and to a high degree attained, by the present division of the invention, is a large reduction in the amount of material usually necessary for the non-acting, supporting, and conducting portion of a secondary battery element.

I do not limit myself to any specific form of element, as my invention is equally applicable to many forms.

My invention is admirably adapted to the construction of elements made up of very thin strips, plates, wires, or filaments.

Among the substances that may be applied to the alloy core may be mentioned the following, viz.: oxide of lead, electro-deposited lead, a mixture of metallic lead and lead-oxide, or superficially oxidized particles of lead. The alloy core may be suitably roughened, scored, or perforated, to insure retention of the active coating when applied.

In the operation of "forming" such an element, the electric current will not only act upon the coating or covering just described, but it will also superficially affect the core, by converting the lead in the surface of the alloy into peroxide of lead; thus rendering the platinum (or gold) surface of core rough or porous, and greatly facilitating and insuring the adhesion to the core of the active coating, because the pores are now filled with peroxide of lead, which is integral with the peroxide of lead of the active coating proper.

In case the alloy core is in the sheet form, it may be bent, corrugated, roughened, perforated, slotted, or otherwise prepared; and if the wire or filament form of core be used, a number of these may be electrically connected together, either at one or both ends, and arranged in a substantially parallel relation with each other; or they may be twisted into a skein, or bunched together in any manner; or they may be woven into a netting or fabric. Instead of the alloy being composed simply of lead and platinum, or lead and gold, it may consist of lead with any other unoxidizable alloy or substance whatever.

The

*Improvements in Secondary Batteries or Magazines of Electricity.*

The amount of lead in the alloy should be so limited in quantity that the oxidizing action in "forming" the element shall be confined to the surface of the alloy; the interior portions being practically protected by the excess of non-oxidizable metal. Such a construction will permit of the use of very thin wires, sheets, or strips of alloy, without danger of complete oxidation; thus effecting an economy in the amount of the non-oxidizable material forming the supporting and electro-conducting core, and obtaining a very large amount of available active material for any given amount of space occupied by the element.

Such a construction as I have described prevents the spontaneous loss of charge in a secondary battery, due to "local action" between the active portion of the element and its supporting body.

*Division F.*

"Division F" of my invention consists in the following specified plan or arrangement in constructing the elements of secondary batteries:—

In the drawings, figs. 6 and 7 are front views representing various embodiments of my invention according to "Division F."

Fig. 8 is an edge view of the forms shown in figs. 6 and 7.

*a a* are two or more strips, bars, or sheets of lead (or any other material suitable for use in secondary battery elements), "formed" or provided with an active coating in any suitable manner.

*b* is a uniting and sustaining piece, made of any material from which the parts *a* can be constructed.

The parts *a* and *b* may be joined by being soldered together in the relation indicated, or the parts *a* may be held in proper position and relation while the part *b* is cast upon the ends of the parts *a*; or the entire structure may be cast at one operation.

The parts *a* may be united not only by the bar *b*, but by one or more additional rods, bars, webs, or other stays, *c*, to give greater stability to the structure, as shown in fig. 7. The part *c* need not necessarily make electrical connection with the parts *a*, but may consist of a rod passed through suitable perforations in the latter, the parts *c* being used simply to retain the otherwise free ends of the parts *a* in proper relation to each other.

Among the advantages pertaining to a battery element constructed as above specified may be mentioned: first, the element presents many small surfaces instead of a few large ones, upon which small surfaces the active coating of the element can expand or contract, without that liability to blister or peel off that exists in the case of more extended surfaces; second, there is a large amount of aggregate active surface exposed in a small space, and a free circulation of the battery-liquid secured around and throughout the element; and, third, the parts *a* may be separately prepared, as, for instance, according to "Division D," and afterwards associated together.

What I claim is:—

- 1st. The process or method of "forming" a plate or element of a secondary battery or current-storing apparatus, consisting in primarily storing or producing upon said plate or element a large amount of peroxide of lead by electrical action, substantially as set forth in "Division A."
- 2nd. The process or method of "forming" the hydrogen plate or element of a secondary battery or current-storing apparatus, consisting in primarily storing or producing upon said plate or element a large amount of peroxide of lead by electrical action, and then reducing the oxide of lead to the metallic state by the reverse action of the charging current, substantially as set forth in "Division A."
- 3rd. In a process of "forming" plates or elements of secondary batteries or current-storing apparatus, electrically charging simultaneously two or more elements with peroxide of lead, substantially as set forth in "Division A."
- 4th. In a secondary battery or current-storing apparatus, one or more plates coated or combined with electrically deposited coherent lead, substantially as set forth in "Division B."
- 5th. In a secondary battery or current-storing apparatus, one or more corrugated plates coated or combined with electrically deposited coherent lead, substantially as set forth in "Division B."
- 6th. In a secondary battery or current-storing apparatus, one or more ribbed, cellular, or perforated plates coated or combined with electrically deposited coherent lead, substantially as set forth in "Division B."
- 7th. In a secondary battery or current-storing apparatus, elements coated or combined with electrically deposited coherent lead, and "formed" as specified in "Division A," substantially as set forth in "Division B."
- 8th. In secondary batteries or current-storing apparatus, ribbed, cellular, perforated, or equivalent elements, coated or combined with electrically deposited coherent lead, and "formed" according to the process described in "Division A," substantially as set forth in "Division B."
- 9th. The process described in "Division B" of depositing coherent metal within the cells, grooves, or corrugations of a secondary battery plate or element.
- 10th. As a new article of manufacture, a substance formed of small pieces of lead having oxidized surfaces, that have been united by pressure into a coherent mass, substantially as set forth in "Division D."
- 11th. As a new article of manufacture, a mass consisting of a mechanical mixture or association of metallic lead and oxide of lead, united by pressure into a coherent and firm body, substantially as set forth in "Division D."
- 12th. A process for manufacturing a material from which the elements of a secondary or electric-storage battery can be constructed; said process consisting in uniting into a compact and firmly coherent body or mass small particles of lead having oxidized surfaces, substantially as set forth in "Division D."
- 13th. A process for manufacturing a material from which the elements of a secondary or electrical-storage battery can be constructed; said process consisting in taking finely divided, granulated, or pulverized lead, the particles of which have oxidized surfaces, and subjecting

*Improvements in Secondary Batteries or Magazines of Electricity.*

- subjecting said oxidized particles to pressure sufficient to unite them into a compact and firmly coherent body or mass, substantially as set forth in "Division D."
- 14th. For use in an element of a secondary battery, a metallic core or body, to one or more sides of which is attached a mass or substance primarily consisting of metallic lead and oxide of lead united by pressure, so as to be strong and firmly coherent, substantially as set forth in "Division D."
- 15th. A secondary battery element, consisting of a metallic core or body, having attached to it a coating primarily consisting of mixed lead and oxide of lead, firmly united by pressure into a strong and firmly coherent mass, substantially as set forth in "Division D."
- 16th. A secondary battery element, consisting of the combination with a metallic supporting core or body of a coating attached or united to said core; said coating primarily consisting of metallic lead and lead-oxide in an intimately commingled state, united by pressure into a strong and firmly coherent mass, substantially as set forth in "Division D."
- 17th. A process for making secondary battery elements (or material from which said elements can be constructed), said process consisting in covering one or more or all of the surfaces of a suitable metallic and electro-conducting core or body, either with superficially oxidized particles of lead, or with a mixture of particles of pure lead and lead-oxide, and afterwards applying pressure sufficient both to unite said particles or mixture into a compact and firmly coherent mass, and to unite the mass to the core or body, as set forth in "Division D."
- 18th. An alloy of lead and a non-oxidizable substance as a material entering into the primary construction of a secondary battery element, substantially as set forth in "Division E."
- 19th. In a secondary battery element, the combination (in the form of an alloy) of lead and a non-oxidizable substance, substantially as set forth in "Division E."
- 20th. A secondary battery element, having its active or absorbing coating, substance, or surface applied to and connected with a core or body consisting of an alloy of lead and a non-oxidizable substance, substantially as set forth in "Division E."
- 21st. An element for a secondary battery, consisting of the strips, bars, or plates *a*, and connections *b*, and stays or supports *c*, substantially as set forth in "Division F."
- 22nd. An element for a secondary battery, consisting of a series of narrow sheets or plates, associated together substantially as indicated, and all connected by a common bar or support, *b*, substantially as set forth in "Division F."

CHARLES FRANCIS BRUSH,  
(Per EDWD. WATERS, his Agent).

This is the specification referred to in the annexed Letters of Registration granted to Charles Francis Brush, this twenty-seventh day of June, A.D. 1883.

AUGUSTUS LOFTUS.

### REPORT.

Sir,

Sydney, 11 May, 1883.

We do ourselves the honor to report, in reply to your blank cover minute of the 5th instaut, No. 5,622, that we are of opinion that Letters of Registration for an invention entitled "Improvements in Apparatus for Automatically manipulating the current employed in charging Secondary Batteries or Magazines of Electricity" may now be granted in favour of Mr. Charles Francis Brush, in accordance with his revised specification, drawings, and claim.

We have, &c.,

E. C. CRACKNELL.  
GOTHER K. MANN.

The Under Secretary of Justice.

[Drawings - one sheet.]

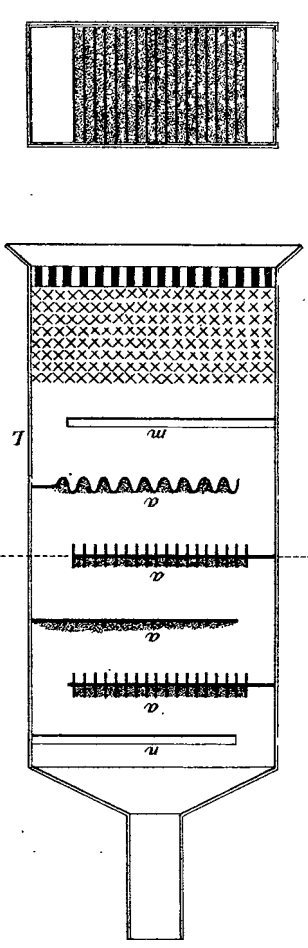


Fig. 4.  
"C"

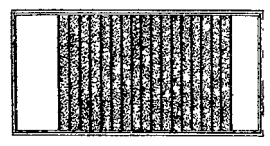


Fig. 5.  
"C"

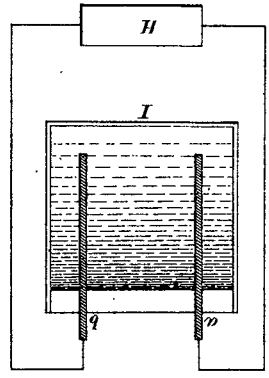


Fig. 2.  
"A"

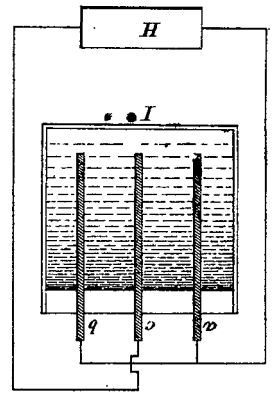


Fig. 1.  
"A"

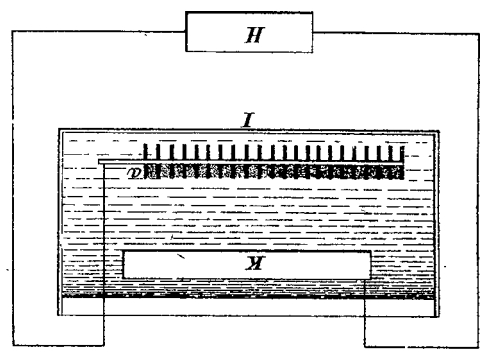


Fig. 3.  
"B"

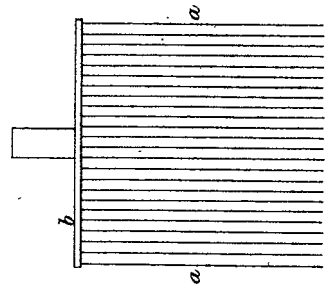


Fig. 6.  
"F"

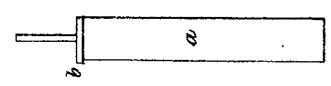


Fig. 8.  
"F"

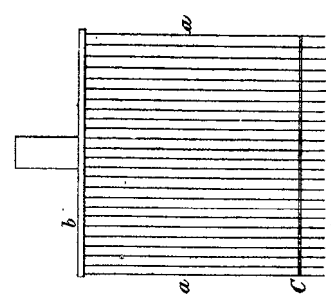


Fig. 7.  
"F"

This is the Sheet of Drawings referred to in the annexed Letters of Registration granted to Charles Francis Augustus Loftus. Brush this twenty-seventh day of June, A. D. 1883.

(Sig. 35-)



A.D. 1883, 29th June. No. 1266.

IMPROVEMENTS IN STOPPERING BOTTLES.

LETTERS OF REGISTRATION to William Wilson Macvay and Richard Sykes,  
for Improvements in Stoppering Bottles.

[Registered on the 2nd day of July, 1883, in pursuance of the Act 16 Vic. No. 24.]

BY HIS EXCELLENCY THE RIGHT HONORABLE SIR AUGUSTUS WILLIAM FREDERICK SPENCER LOFTUS (commonly called LORD AUGUSTUS LOFTUS), Knight Grand Cross of the Most Honorable Order of the Bath, a Member of Her Majesty's Most Honorable Privy Council, Governor and Commander-in-Chief of the Colony of New South Wales and its Dependencies.

TO ALL TO WHOM THESE PRESENTS SHALL COME, greeting :

WHEREAS WILLIAM WILSON MACVAY and RICHARD SYKES, both of Castleford, in the County of York, England, Glass Manufacturers, have by their Petition humbly represented to me that they are the authors or designers of a certain invention or improvement in manufactures, that is to say, of an invention entitled "Improvements in Stoppering Bottles," which is more particularly described in the specification and the sheets of drawings which are hereunto annexed; and that they, the said Petitioners, have deposited with the Honorable the Treasurer of the said Colony of New South Wales the sum of Twenty Pounds sterling, for defraying the expense of granting these Letters of Registration, as required by the Act of Council, sixteenth Victoria, number twenty-four; and have humbly prayed that I would be pleased to grant Letters of Registration whereby the exclusive enjoyment and advantage of the said invention or improvement might be secured to them for a period of fourteen years: And I, being willing to give encouragement to all inventions and improvements in the arts or manufactures which may be for the public good, and having received a report favourable to the prayer of the said Petition, from competent persons appointed by me to examine and consider the matters stated therein and to report thereon for my information, am pleased, with the advice of the Executive Council, and in exercise of the power and authority given to me by the said Act of Council, to grant, and do by these Letters of Registration grant unto the said William Wilson Macvay and Richard Sykes, their executors, administrators, and assigns, the exclusive enjoyment and advantage of the said invention or improvement, for and during the term of fourteen years from the date hereof; to have, hold, and exercise unto the said William Wilson Macvay and Richard Sykes, their executors, administrators, and assigns, the exclusive enjoyment and advantage thereof, for and during and unto the full end and term of fourteen years from the date of these presents next and immediately ensuing, and fully to be complete and ended: Provided always, that if the said William Wilson Macvay and Richard Sykes shall not, within three days after the granting of these Letters of Registration, register the same in the proper office in the Supreme Court, at Sydney, in the said Colony of New South Wales, then these Letters of Registration, and all advantages whatsoever hereby granted, shall cease and become void.

In witness whereof, I have hereunto set my sign manual, and have caused the present Letters of Registration to be sealed with the seal of the said Colony of New South Wales, at Government House, Sydney, in New South Wales, this twenty-ninth day of June, in the year of our Lord one thousand eight hundred and eighty-three.

[L.S.]

AUGUSTUS LOFTUS.

*Improvements in Stoppering Bottles.*

SPECIFICATION of WILLIAM WILSON MACVAY and RICHARD SYKES, both of Castleford, in the County of York, England, Glass Manufacturers, for "Improvements in Stoppering Bottles."

THE object of this invention is to provide tight, convenient, cheap, and neat means of stoppering bottles, more particularly those containing aerated liquids.

Figure 7 shows a sectional elevation of an arrangement in which we form two or more lugs or projections *a a* preferably midway or thereabout, between the surface of the neck *b* of the bottle and the ledge *c*, on which the elastic washer or ring *d* (shown in half sectional elevation) rests.

A cap or ferule *e* similar to that shown in half section at figure 7, in elevation at figure 8, and in sectional plan at figure 9, is employed; but instead of screwing into the neck, as before described, it is provided with lugs *f f* or projections, so that the cap or ferule *e* may be dropped into the neck of the bottle, and by giving the cap or ferule a partial turn in the neck, the lugs or projections *f f* on same are brought beneath the lugs or projections *a* on the inside of the bottle neck. Figure 8 shows the cap *e* as dropped into the neck of the bottle, and figures 7 and 9 as fixed after having received half a turn, the lugs *f f* on the cap or ferule *e* having been brought under the lugs *a a* on the inside of the bottle neck.

Figure 10 shows in sectional elevation another arrangement, in which we cut away at intervals portions of screw threads formed on the inside of the bottle neck, as before described leaving part threads as shown at *a a*, figures 10, 11, and 12. The cap or ferule *e e*, shown in half section at figure 10, inside elevation (figure 11), and in sectional plan (figure 12), is also provided with screw threads *f f*, cut away at intervals so that the cap or ferule *e* may be dropped into the neck of the bottle as at figure 11; and by giving the same a half turn may be securely fixed as at figure 10. Figure 13 shows a modification where two washers *d* and *d'* are used, the upper washer *d* being preferably of indiarubber or other similar material, and the lower *d'* of cork for the purpose of preventing the taste which aerated waters so frequently acquire from direct contact with indiarubber.

The cap or ferule may be made of glass, metal, wood or composition, and in some cases it may be advantageous to make it solid or partially so. When the invention is applied to the stoppering of bottles containing aerated liquids, we drop the marble *g* into the bottle first, then the elastic washer *d* is placed on the ledge, and lastly the ferule *e* is inserted and secured, as before described with reference to the drawing. The ferule or plug should have projecting studs thereon, or recesses therein, to enable a tool to be with facility inserted, for the purpose of removing easily the said ferule or stopper from the neck of the bottle for cleaning same, or the insertion of a new ball, or otherwise.

Having thus described and explained the nature of this invention we would have it understood that we do not claim to have invented means for stoppering bottles in which the necks are formed with internal or external screw threads, and in which an elastic washer secured by a ferule forms the seat for a glass or other ball; but what we claim as novel and of our invention is—

First—Forming lugs or projections within the neck of a bottle, and corresponding lugs or projections on a ferule, so that the partial revolution of the latter secures an elastic ring or rings to form a seat for a ball or other stopper, substantially as herein described and explained, and as illustrated in figures 7, 8, and 9 of the drawings, and the modification thereof illustrated in figure 13.

Second—Forming a bottle neck with internal or external partial or broken screw threads (in contradistinction to whole or continuous threads), and the ferule with like partial threads, substantially as herein described and explained, and as illustrated in figures 10, 11, and 12 of the drawings.

WM. W. MACVAY,  
RICHD. SYKES,  
(By their agent, EDWD. WATERS).

This is the specification referred to in the annexed Letters of Registration granted to William Wilson Macvay and Richard Sykes, this 29th day of June, A.D. 1883.

AUGUSTUS LOFTUS.

### REPORT.

Sir,

The application of Messrs. William Wilson Macvay and Richard Sykes, for "Improvements in Stoppering Bottles," having been referred to us, we have the honor to report that the specification and drawings accompanying the same involve so much of what is already secured by Letters of Registration, or is otherwise in use, that we are quite unable to recommend the granting of the present application.

We have, &c.,  
CHAS. WATT.  
A. LEIBIUS.

The Under Secretary of Justice.

Sir,

The amended specification and drawings of Messrs. William Wilson Macvay and Richard Sykes, for "Improvements in Stoppering Bottles," having been referred to us, we now have the honor to report that we see no objection to the granting of the same. With regard to the observation made by Mr. Walsh in his letter to you of the 7th instant, viz., "it is customary for the examiners to suggest that if certain portions are left out others might be considered," we beg to state that in this case it has been found necessary to omit so large a proportion of the original specification and claims, as compared with those now under consideration, that we determined upon the conclusion as contained in our first report.

We have, &c.,  
CHAS. WATT.  
A. LEIBIUS.

The Under Secretary of Justice.



Fig. 7.

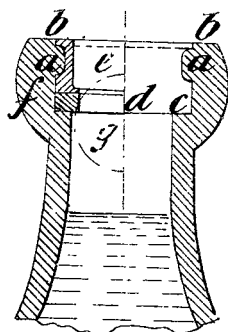


FIG. 10

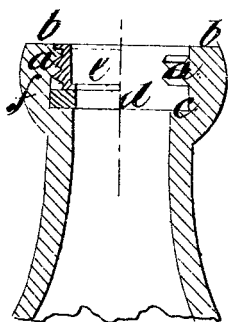


Fig. 8.

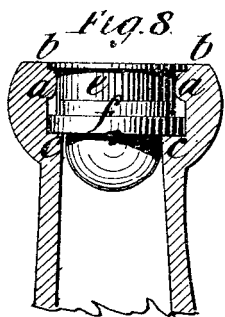


Fig. 11

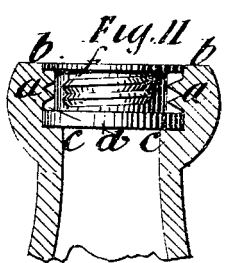


Fig. 9.

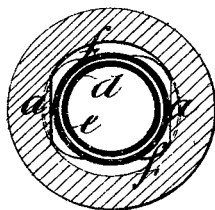


Fig. 12

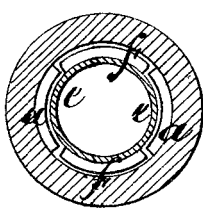
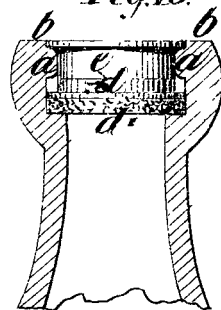


Fig. 13.



*This is the Sheet of Drawings referred to in the annexed  
Letters of Registration granted to William Wilson Macway,  
and Richard Sykes, this 29<sup>th</sup> day of June A. D. 1883.  
Augustus Loftus.*

PHOTO-LITHOGRAPHED AT THE GOVT. PRINTING OFFICE,  
SYDNEY, NEW SOUTH WALES.



A.D. 1883, 29th June. No. 1267.

IMPROVEMENTS IN OBTAINING AND APPLYING MOTIVE POWER.

LETTERS OF REGISTRATION to James Robson, for an invention entitled  
 "Improvements in Obtaining and Applying Motive Power."

[Registered on the 2nd day of July, 1883, in pursuance of the Act 16 Vic. No. 24.]

BY HIS EXCELLENCY THE RIGHT HONORABLE SIR AUGUSTUS WILLIAM FREDERICK SPENCER LOFTUS (commonly called LORD AUGUSTUS LOFTUS), Knight Grand Cross of the Most Honorable Order of the Bath, a Member of Her Majesty's Most Honorable Privy Council, Governor and Commander-in-Chief of the Colony of New South Wales and its Dependencies.

TO ALL TO WHOM THESE PRESENTS SHALL COME, greeting:

WHEREAS JAMES ROBSON, of 106, Falmouth Road, in the County of Surrey, in England, hath by his Petition humbly represented to me that he is the author or designer of a certain invention or improvement in manufactures, that is to say, of an invention entitled "Improvements in Obtaining and Applying Motive Power," which is more particularly described in the specification marked "A" and the two sheets of drawings marked "B" and "C" respectively, and which are hereunto annexed; and that he, the said Petitioner, hath deposited with the Honorable the Treasurer of the said Colony of New South Wales the sum of Twenty Pounds sterling for defraying the expense of granting these Letters of Registration, as required by the Act of Council sixteenth Victoria, number twenty-four; and hath humbly prayed that I would be pleased to grant Letters of Registration, whereby the exclusive enjoyment and advantage of the said invention or improvement might be secured to him for a period of fourteen years: And I, being willing to give encouragement to all inventions and improvements in the arts or manufactures which may be for the public good, and having received a report favourable to the prayer of the said Petition, from competent persons appointed by me to examine and consider the matters stated therein and to report thereon for my information, am pleased, with the advice of the Executive Council, and in exercise of the power and authority given to me by the said Act of Council, to grant, and do by these Letters of Registration grant unto the said James Robson, his executors, administrators, and assigns, the exclusive enjoyment and advantage of the said invention or improvement, for and during the term of fourteen years from the date hereof; to have, hold, and exercise unto the said James Robson, his executors, administrators, and assigns, the exclusive enjoyment and advantage thereof, for and during and unto the full end and term of fourteen years from the date of these presents next and immediately ensuing, and fully to be complete and ended: Provided always, that if the said James Robson shall not, within three days after the granting of these Letters of Registration, register the same in the proper office in the Supreme Court, at Sydney, in the said Colony of New South Wales, then these Letters of Registration, and all advantages whatsoever hereby granted, shall cease and become void.

In witness whereof, I have hereunto set my sign manual, and have caused the present Letters of Registration to be sealed with the seal of the said Colony of New South Wales, at Government House, Sydney, in New South Wales, this twenty-ninth day of June, in the year of our Lord one thousand eight hundred and eighty-three.

[L.S.]

AUGUSTUS LOFTUS.

*Improvements in Obtaining and Applying Motive Power.*

A.

SPECIFICATION of JAMES ROBSON of 106, Falmouth Road, in the County of Surrey, in England, for an invention entitled "Improvements in Obtaining and Applying Motive Power."

My invention of improvements in obtaining and applying motive power consists in the following application of explosive gases and air for producing motion in various machines, such as pumping water or other liquids or gaseous fluids, or hammering or stamping. In carrying out my invention as applied to pumping, I use a cylinder (which may be water-jacketted) and a piston and rod working therein. On the outer end of this rod is attached a pump-bucket or piston working in an ordinary pump barrel; also on the rod is a cross-head, to which are attached steel, volute, or other springs, to absorb the energy developed behind the piston by the explosion of a mixture of gas and air. In the exploding cylinder is another piston and rod, moved either by hand or self acting gear, so that when this charging piston is moved away from the main piston, it draws in between these pistons a charge of explosive gas or vapour and air through a flap or other shaped valve covering by its face the gas and air inlets simultaneously. On this piston reaching the end of its stroke, it covers an exhaust port, and uncovers a small hole in the cylinder side, or removes a plate away from a hole in the portway, and allows a standing flame to be sucked in through the hole and fire the gases. The explosion drives the main piston to the other end of the cylinder, and does work in compressing or extending springs, and at the same time compels the water in the pump to pass from one side of its piston to the other, and lift the water on its return stroke by the potential energy now contained with springs. I prefer to have the springs in an initial state of tension at the beginning of the operation. When used as a ram plunger or high-pressure pump, the main piston on its outstroke drives the ram plunger into its case and the liquid out into the accumulator or high-lift pipe. To prevent the sudden shock from the quick motion of the explosion, I use a small ram loaded by similar volute or other springs between the pump and the accumulator, or an air vessel might be used to lessen the shock. The main piston and ram are drawn back and its case charged with liquid by springs. The charging-piston is worked by a lever and weight or spring in its charging and firing stroke, and on its inward or exhausting stroke by a spring extended and held on a catch by the motion of the outstroke of the main piston and rod. When it completes its instroke, it releases the spring from the catch, and allows the weight to make the outstroke; or the weight and lever of the charging piston may be lifted by a small piston worked in a cylinder on its upstroke by the liquid from the accumulator or cistern, and allowed to escape on its descent. It may also be worked by a connecting rod to a fly-wheel put in motion by hand, or by the motion of the main piston and springs. By attaching a hammer head to the main piston rod instead of a pump, it can be used as a forging hammer or stamper, the cylinder being vertical with the hammer attached to its main piston rod. The piston is driven down by the explosion of the gases between its upper side and the charging piston, the charging piston being worked by a hand-lever or hand-wheel with crank and connections to its rod, the gas and air supply and firing and exhaust being same as the pump. The hammer and main piston are drawn up to the top by springs.

In order that my invention may be better understood, I now proceed to describe the same by reference to the accompanying drawings, that is to say:—

## Description of the Drawings.

Figs. A to J are various views to my pumping arrangements; the same numerals apply to same parts in all the views. 1 is the cylinder; 2, the main piston with its rod 3 connected to pump bucket 4 in its case 5, with ordinary inlet valve 6, discharge valve 7, and bucket valve 8. 9 is the charging piston which, when moved back by the lever 10 and weight 11, draws in between the pistons a charge of gas and air through the valve 12; then it covers the exhaust port 13, and passes the igniting port 14, and draws in a part of an outside constant burning flame 15, which explodes the gases and propels the main piston and its rod, cross-head 16 compressing the steel volute or other springs 17 in their cases 18, the springs being connected to the cross-head by rods 19. While the main piston is thus doing work on the springs, the pump bucket is displacing the fluid from one side of it to the other through the valve 8. The springs now draw the main piston and bucket back again and force the fluid through the outlet valve 7, and re-charge the pump through inlet valve 6. Holes 20 allow the air to pass in and out of front end of cylinder; but when main piston passes them, it cushions air between it and cylinder cover. I also provide india-rubber buffers 21 to cushion back stroke of main piston, or an air cushion formed by a short cylinder 22 on main cylinder cover, into which goes a piston 23, and cushions on the air in it. The exhaust passes through a lift valve 24 as the pistons come together, and then expelled through the exhaust port 13 in the backward stroke of the charging piston. When used as a ram pump, fig. E, the plunger 25 is attached to the main piston rod, which on its outstroke drives the plunger into its casing, and the liquid out through valve 26, into the accumulator or high-lift pipe as in ordinary ram pumps. 27 is suction valve.

To prevent sudden shocks from the quick motion, I use a ram 28, loaded by volute or other springs 29 between the pump and the accumulator. The charging piston 9 may be worked by hand or by a cranked lever 10, and weight 11 on its out or charging and firing stroke, and on its inward by a spring and tube 30, extended and held on a catch 31 by the motion of the main piston cross-head 16 acting on the bent lever 32. When the charging piston completes its inward stroke, it releases the catch 31 from the tube and spring 30 by a rod 33 attached to the lever 10, and this allows the weight 11 to draw the charging piston out, and the spring tube and lever 32 back again; or the weight 11 and lever 10 may be lifted by a small piston worked in a cylinder 34, fig. F, on its upstroke by the liquid from the accumulator or cistern, an ordinary admission and escape valve 35 being used and moved up or down by the lever 10, by projections on the escape valve rod at 36. When the accumulator is full, it slackens a wire 37, and drops the stop 38 under the lever 10, and arrests the motion of the pump.

Figs. C and D show another method of working the charging piston. A fly-wheel 39, fixed on a shaft 40, having a disc crank 41, moves a connecting rod 42 and charging piston and rod 9. The fly-wheel can be kept in motion by hand or by a V eccentric friction, gripper 43, working in a V nick on the rim of the crank disc. When the main piston is propelled out, it moves with it a connecting rod 44, and lever 45, on which the gripper moves, the gripper in the outstroke sliding round the disc, but by means of its eccentricity grips the disc in the instroke, and gives motion to the disc and fly-wheel.

By

*Improvements in Obtaining and Applying Motive Power.*

By detaching the pump, this last arrangement may be used as an ordinary motor for giving motion to other mechanism. At 14 and 15, fig. C, is the flame and firing hole in the cylinder side, but sometimes I put the firing hole in the tubular portway from the gas and air feed valve 12, as at 45. The standing flame 15 is prevented from entering the firing hole by a plate 46, until the charging piston is at the back of its stroke, when a stop 47, on the connecting-rod 42, moves the plate 46 away, and allows the flame to go over and into the firing hole, as better seen in fig. I. At the explosion, a small valve 48 closes the firing hole, or the firing hole may be closed as at fig. J. 49 is a small cylinder and piston; 50 is the firing hole in main cylinder or portway; 51, a sliding plate fixed to small piston rod. When the flame 15 explodes the gases in the main cylinder, the pressure communicates through the port 52 under the small piston, and drives it out, and the plate 51 closes the firing hole 50, a spring 53 pushing the piston back. Figs. G and H are views of the feed valve, 54 being the gas entrance, and 55, the air-ways, the valve 12 moving on a pin 56, and closing gas and air at same time. The feed valve 12 may be closed just before explosion by a pin 57 on connecting rod 42 moving a hinged lever 58. The energy of the explosion may be absorbed by pistons 59 attached to the cross-head, and working in the spring cases 18, to form a vacuum instead of springs. 60 is an outward sniffing valve for forcing out any air leakage. Figs. K and L are the application to forging hammers; 61 is the hammer on end of piston rod; 62, the anvil. The explosion cylinder is the same as in the pump, the charging piston being worked by the hand-wheel 39, the springs in cases 18 just being sufficient to raise the hammer to the top. Figs. M and N are views of my improvements applicable to lifts, cranes, or the like machines. 1 is the cylinder. The free piston 2, rod 3, and cross-head 16 are attached by connecting rods 63 to levers 64 on the main shaft 40. Between the levers and fixed on the shaft is a disc 41 with a V friction nick on its circumference, in which works a V shaped eccentric pawl gripper 43. When the gases are exploded in the pump 65, communicating by port 66 with cylinder 1, they propel the piston 2 and its rod cross-head with connecting rods 63, levers 64, pawl 43 out, and so far round the gripper disc 41, at the same time compressing the springs in their cases 18. The springs now draw them back, and with them the gripper disc and shaft with lift pulley or crane barrel 72 attached or geared thereto; the pawl 43 may be released at the finish of each inward stroke by its top 67 striking top 68. The load may be suspended by another gripper pawl 69, or by any ordinary friction brake or clutch 70, which may be used for lowering. The charging pump piston 9 may be either worked by a handle or spocket wheel 39, encircled by a rope or chain 71, from any convenient position; the spocket wheel, shaft, and crank 41 are connected to and work the pump piston by the rod 42 and lever 10; the gas and air-valve 12, firing, and escape being the same as in my other improvements.

Having now particularly described and explained the nature of the said invention, and in what manner the same is to be performed or carried out in practice, I hereby declare that I claim—

- (Firstly), Applying motive power obtained from the explosion of gases to working liquid or gaseous fluid pumps, as shown in figs. A to J, or any mere modification thereof;
- (Secondly), The use of steel volute or other springs or vacuum cylinders for storing the energy developed by explosive gas on a piston, and applying the energy to working pumps for various fluids or any mere modification thereof;
- (Thirdly), Operating the charging piston in gas motors for pumping by the method shown in fig. F, or any mere modification thereof;
- (Fourthly), The arrangement of ram pump as shown in fig. E, or any mere modification thereof;
- (Fifthly), Closing the firing hole in gas motors by the arrangement shown in fig. J, or any mere modification thereof;
- (Sixthly), The application of the same arrangements as herein set forth to forging hammers, as shown in figs. K and L, or any mere modification thereof;
- (Seventhly), Applying motive power obtained from the explosion of gases to working lifts, hoists, or cranes, as shown in figs. M and N, or any mere modification thereof.

In witness whereof, I, the said James Robson, have hereto set my hand and seal, the twenty-first day of December, A.D. 1882.

Witness—

JAMES ROBSON, Junr.,  
247 Icknield-street, Birmingham, England.

JAMES ROBSON.

This is the specification marked "A" referred to in the annexed Letters of Registration granted to James Robson, this twenty-ninth day of June, A.D. 1883.

AUGUSTUS LOFTUS.

### REPORT.

Sir,

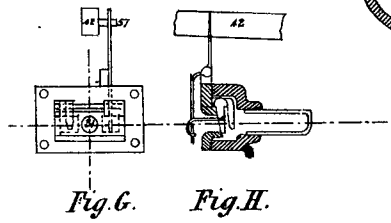
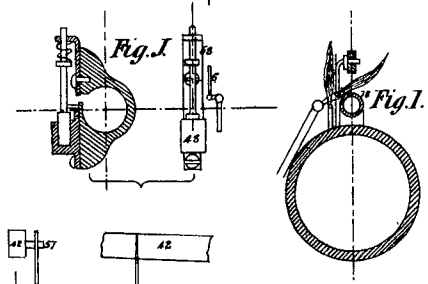
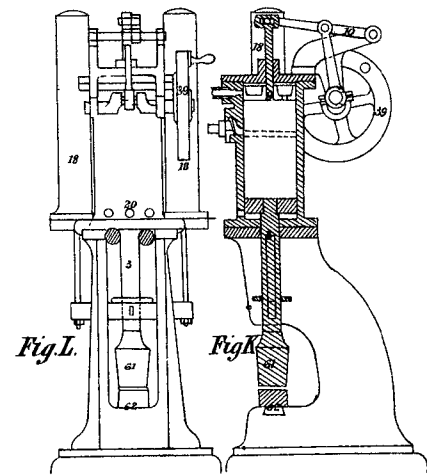
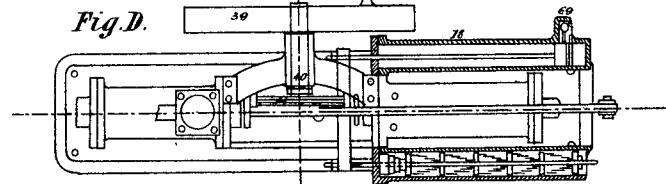
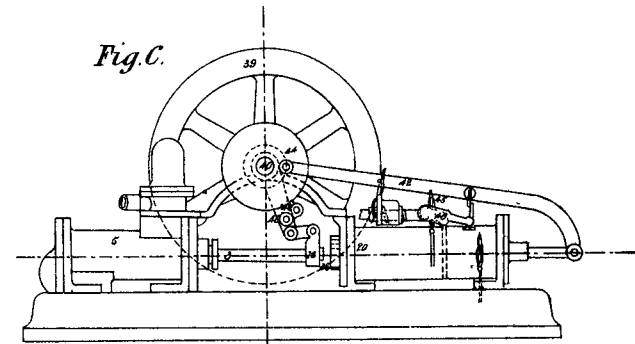
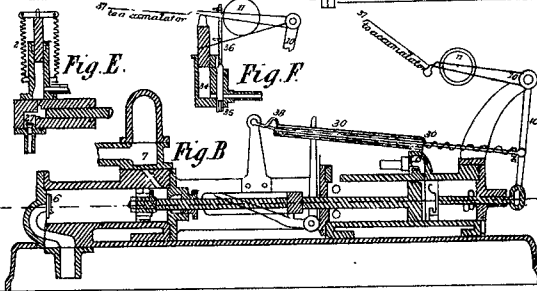
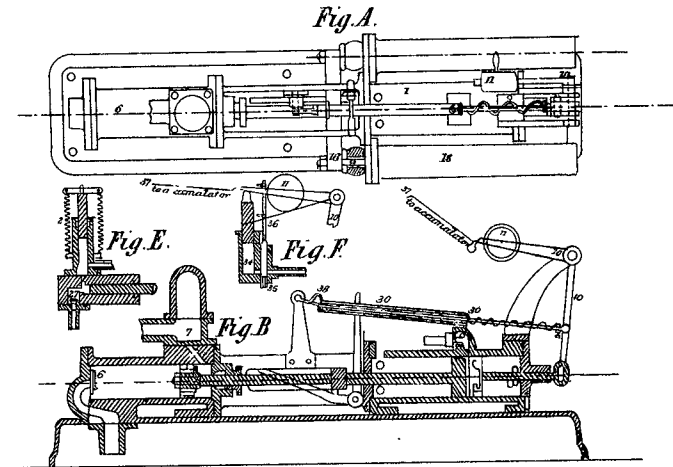
Replying to your B.C. memo. of the 10th instant, forwarding a Petition for Letters of Registration for an invention entitled "Improvements in Obtaining and Applying Motive Power," from Mr. James Robson, we have the honor to inform you that, having examined the plans and specification accompanying the Petition, we recommend that Letters of Registration should be issued to the Petitioner for the invention referred to, as shown in the drawings and described in the specification attached to his Petition.

All papers are returned herewith.

The Under Secretary of Justice.

Sydney, 14 May, 1883.

We have, &c.,  
JOHN WHITTON.  
E. O. MORIARTY.



*This is the Sheet of Drawings marked B preferred to in the annexed Letters of Registration granted to James Robson this 29<sup>th</sup> day of June A. D. 1883.*

*Augustus Loftus.*

Fig. M.

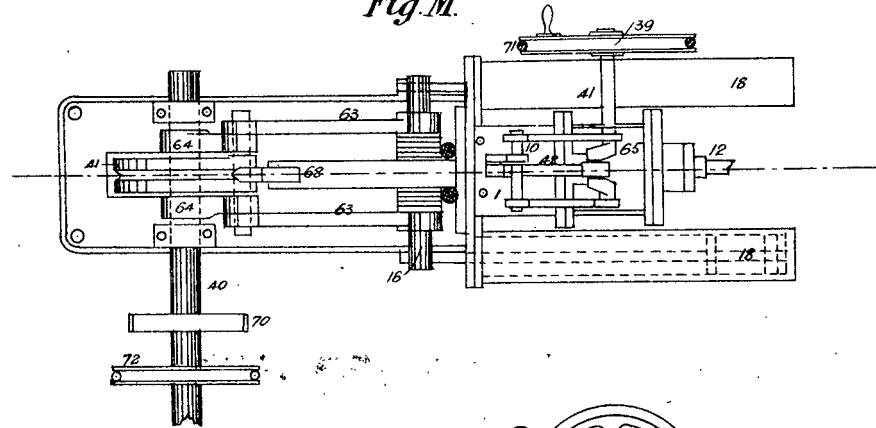
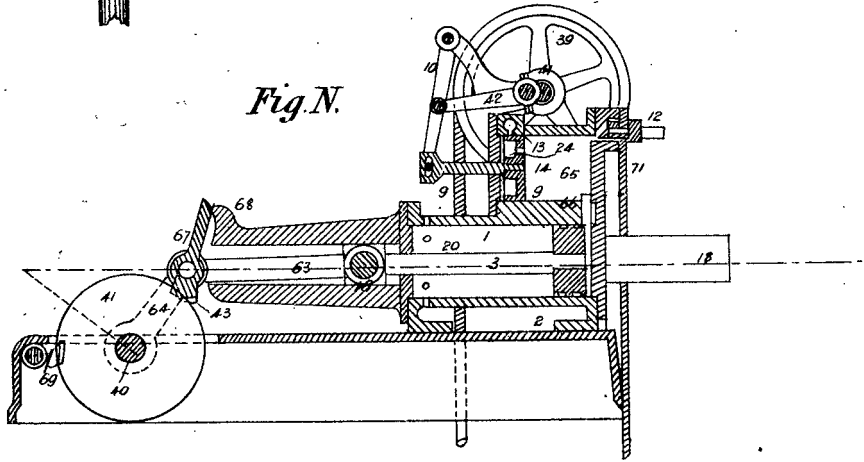


Fig. N.



*This is the Sheet of Drawings marked C. referred to in the annexed  
Letters of Registration granted to James Robson this 29<sup>th</sup> day of  
June A.D. 1883.*

*Augustus Loftus*



A.D. 1883, 29th June. No. 1268.

**IMPROVEMENTS IN THE DISTILLATION OF COAL FOR OBTAINING PRODUCTS THEREFROM.**

LETTERS OF REGISTRATION to William John Cooper, for Improvements in the Distillation of Coal for obtaining products therefrom.

[Registered on the 2nd day of July, 1883, in pursuance of the Act 16 Vic. No. 24.]

BY HIS EXCELLENCY THE RIGHT HONORABLE SIR AUGUSTUS WILLIAM FREDERICK SPENCER LOFTUS (commonly called LORD AUGUSTUS LOFTUS), Knight Grand Cross of the Most Honorable Order of the Bath, a Member of Her Majesty's Most Honorable Privy Council, Governor and Commander-in-Chief of the Colony of New South Wales and its Dependencies.

TO ALL TO WHOM THESE PRESENTS SHALL COME, greeting :

WHEREAS WILLIAM JOHN COOPER, of Westminster Chambers, Westminster, in the County of Middlesex, England, Analytical Chemist, hath by his Petition humbly represented to me that he is the author or designer of a certain invention or improvement in manufactures, that is to say, of an invention entitled "Improvements in the Distillation of Coal for obtaining products therefrom," which is more particularly described in the specification which is hereunto annexed; and that he, the said Petitioner, hath deposited with the Honorable the Treasurer of the said Colony of New South Wales the sum of Twenty Pounds sterling, for defraying the expense of granting these Letters of Registration, as required by the Act of Council, sixteenth Victoria, number twenty-four, and hath humbly prayed that I would be pleased to grant Letters of Registration, whereby the exclusive enjoyment and advantage of the said invention or improvement might be secured to him for a period of fourteen years: And I, being willing to give encouragement to all inventions and improvements in the arts or manufactures which may be for the public good, and having received a report favourable to the prayer of the said Petition, from competent persons appointed by me to examine and consider the matters stated therein, and to report thereon for my information, am pleased, with the advice of the Executive Council, and in exercise of the power and authority given to me by the said Act of Council, to grant, and do by these Letters of Registration grant unto the said William John Cooper, his executors, administrators, and assigns, the exclusive enjoyment and advantage of the said invention or improvement, for and during the term of fourteen years from the date hereof; to have, hold, and exercise unto the said William John Cooper, his executors, administrators, and assigns, the exclusive enjoyment and advantage thereof, for and during and unto the full end and term of fourteen years from the date of these presents next and immediately ensuing, and fully to be complete and ended: Provided always, that if the said William John Cooper shall not, within three days after the granting of these Letters of Registration, register the same in the proper Office in the Supreme Court, at Sydney, in the said Colony of New South Wales, then these Letters of Registration, and all advantages whatsoever hereby granted, shall cease and become void.

In witness whereof, I have hereunto set my sign manual, and have caused the present Letters of Registration to be sealed with the seal of the said Colony of New South Wales, at Government House, Sydney, in New South Wales, this twenty-ninth day of June, in the year of our Lord one thousand eight hundred and eighty-three.

[L.S.]

AUGUSTUS LOFTUS.

---

*Improvements in the Distillation of Coal for obtaining products therefrom.*

---

SPECIFICATION of WILLIAM JOHN COOPER, of Westminster Chambers, Westminster, in the County of Middlesex, England, Analytical Chemist, for "Improvements in the Distillation of Coal for obtaining products therefrom."

THIS invention relates to improvements in the distillation of coal, and it consists in adding lime in the condition of hydrate of lime, or of slaked lime, or quick lime, or carbonate of lime, or chalk, or spent lime, or mixtures of the same, to the said coal, in such a proportion as shall when the mixture is subjected to distillation produce among other products an increased quantity of ammonia and of ammoniacal products than is now obtained.

To the coal, either in a lumpy condition (such as that in which coal is used in gas-making) or by preference in a state of fine division, I add lime in any of the conditions or compounds mentioned, and I cause the mixture to be well incorporated.

The mixture thus prepared can then be employed either in gas-retorts, coke-ovens, or furnaces.

When I employ the mixture in gas-retorts in gasworks I find it convenient to take quick lime, and to employ about half a hundred-weight of the quick lime to every ton of coal, and I slake the lime with about its own weight of water, whereby it is brought into such condition as to be readily mixed with the coal.

The small coal, or slack, which has comparatively little commercial value as coal, is especially available for the purposes of my invention.

Some of the advantages afforded by my invention when it is applied in gasworks are an increased yield of ammonia and ammoniacal products.

An increased yield of those compounds which impart illuminating power to gas, and consequently an increased yield of illuminating gas.

A diminution of the impurities in crude gas, *i.e.*, in gas as it issues from the retort, and consequently a diminution of the cost of gas purification.

The resulting coke is for certain purposes improved.

CLAIM.

The improvements in the distillation of coal in and for the manufacture and production of coal-gas or of illuminating gas, consisting in the admixture and use of lime (in any of the forms or compounds mentioned) with coal, substantially in the manner and for the purposes hereinbefore mentioned.

In witness whereof, I, the said William John Cooper, have hereunto set my hand and seal, this seventeenth day of March, one thousand eight hundred and eighty-three.

(L.S.) W. J. COOPER.

Signed and sealed in the presence of—

CHAS. MILLS,  
47, Lincoln's Inn Fields, London,  
CHAS. JAS. JONES,  
47, Lincoln's Inn Fields, London.

This is the specification referred to in the annexed Letters of Registration granted to William John Cooper, this twenty-ninth day of June, A.D. 1883.

AUGUSTUS LOFTUS.

---

REPORT.

---

Sir,

The application of Mr. William John Cooper for Letters of Registration for an invention entitled "Improvements in the Distillation of Coal for obtaining products therefrom," having been referred to us, we have the honor to report that we see no objection to the granting of the same.

We have, &c.

A. LEIBIUS.  
CHAS. WATT.

The Under Secretary of Justice.

---





A.D. 1883, 29th June. No. 1269.

PATENT PARAGON FIRE-KINDLERS.

LETTERS OF REGISTRATION to Walter William Cook and Herbert Ligar Cook for an Invention entitled "Patent Paragon Fire-kindlers."

[Registered on the 2nd day of July, 1883, in pursuance of the Act 16 Vic. No. 24.]

BY HIS EXCELLENCY THE RIGHT HONORABLE SIR AUGUSTUS WILLIAM FREDERICK SPENCER LOFTUS (commonly called LORD AUGUSTUS LOFTUS), Knight Grand Cross of the Most Honorable Order of the Bath, a Member of Her Majesty's Most Honorable Privy Council, Governor and Commander-in-Chief of the Colony of New South Wales and its Dependencies.

TO ALL TO WHOM THESE PRESENTS SHALL COME, greeting :

WHEREAS WALTER WILLIAM COOK, and HERBERT LIGAR COOK of No. 225, Elizabeth-street, in the City of Sydney and Colony of New South Wales, timber merchants, have by their Petition humbly represented to me that they are the authors or designers of a certain invention or improvement in manufactures, that is to say, of an invention entitled "Patent Paragon Fire-kindlers," which is more particularly described in the specification which is hereunto annexed; and that they, the said Petitioners, have deposited with the Honorable the Treasurer of the said Colony of New South Wales the sum of Twenty Pounds sterling, for defraying the expense of granting these Letters of Registration, as required by the Act of Council, sixteenth Victoria, number twenty-four, and have humbly prayed that I would be pleased to grant Letters of Registration, whereby the exclusive enjoyment and advantage of the said invention or improvement might be secured to them for a period of fourteen years: And I, being willing to give encouragement to all inventions and improvements in the arts or manufactures which may be for the public good, and having received a report favourable to the prayer of the said Petition, from competent persons appointed by me to examine and consider the matters stated therein and to report thereon for my information, am pleased, with the advice of the Executive Council, and in exercise of the power and authority given to me by the said Act of Council, to grant, and do by these Letters of Registration grant unto the said Walter William Cook and Herbert Ligar Cook, their executors, administrators, and assigns, the exclusive enjoyment and advantage of the said invention or improvement for and during the term of fourteen years from the date hereof; to have, hold, and exercise unto the said Walter William Cook and Herbert Ligar Cook, their executors, administrators, and assigns, the exclusive enjoyment and advantage thereof, for and during and unto the full end and term of fourteen years from the date of these presents next and immediately ensuing, and fully to be complete and ended: Provided always, that if the said Walter William Cook and Herbert Ligar Cook shall not, within three days after the granting of these Letters of Registration, register the same in the proper office in the Supreme Court, at Sydney, in the said Colony of New South Wales, then these Letters of Registration, and all advantages whatsoever hereby granted, shall cease and become void.

In witness whereof, I have hereunto set my sign manual, and have caused the present Letters of Registration to be sealed with the seal of the said Colony of New South Wales, at Government House, Sydney, in New South Wales, this twenty-ninth day of June, in the year of our Lord one thousand eight hundred and eighty-three.

[L. S.]

AUGUSTUS LOFTUS.

SPECIFICATION

---

*Patent Paragon Fire-kindlers.*

---

## SPECIFICATION for the manufacture of Fire-kindlers.

THE Fire-kindlers are proposed to be manufactured of the following ingredients, viz. :—Kerosene shale, coal, grass-tree gum of New South Wales, kauri gum of New Zealand, or gum of other Polynesian Islands, in a powdered state, combined in certain proportions with gas-tar, resin, or resin oil, mixed with sawdust.

The ingredients are placed in an open pot or boiler and well boiled or melted, and properly mixed together.

The mixture is then taken out and poured into moulds, and when slightly cooled the kindlers are taken out of the moulds and packed up for use.

The manufacture of Fire-kindlers from the above-mentioned ingredients, when combined with each other, is claimed as novel and useful, but not any definite quantities of the said ingredients.

WALTER WILLIAM COOK.

HERBERT LIGAR COOK.

Sydney, 225, Elizabeth-street, 1 May, 1883.

(By their Agent, FRED. COOK).

This is the specification referred to in the annexed Letters of Registration granted to Walter William Cook and Herbert Ligar Cook, this 29th day of June, A.D. 1883.

AUGUSTUS LOFTUS.

---

**REPORT.**

---

Sir,

The application of Messrs. W. and H. Cook for Letters of Registration for an invention entitled "Patent Paragon Fire-kindlers" having been referred to us, we have examined the specification accompanying the same, and have now the honor to report that we see no objection to the issue of Letters of Registration as prayed for.

The Under Secretary of Justice.

Sydney, 18 May, 1883.

We have, &c.,

JAMES BARNET.

EDMUND FOSBERY.

---



A.D. 1883, 29th June. No. 1270.

IMPROVEMENTS IN RAILWAY CARS OR WAGGONS.

LETTERS OF REGISTRATION to Carson Woods, for Improvements in Railway Cars or Waggon.

[Registered on the 2nd day of July, 1883, in pursuance of the Act 16 Vic. No. 24.]

BY HIS EXCELLENCY THE RIGHT HONORABLE SIR AUGUSTUS WILLIAM FREDERICK SPENCER LOFTUS (commonly called LORD AUGUSTUS LOFTUS), Knight Grand Cross of the Most Honorable Order of the Bath, a Member of Her Majesty's Most Honorable Privy Council, Governor and Commander-in-Chief of the Colony of New South Wales and its Dependencies.

TO ALL TO WHOM THESE PRESENTS SHALL COME, greeting :

WHEREAS CARSON WOODS, of No. 253, George-street, Sydney, in the Colony of New South Wales, importer, hath by his Petition humbly represented to me that he is the author or designer of a certain invention or improvement in manufactures, that is to say, of an invention entitled "Improvements in Railway Cars or Waggon," which is more particularly described in the specification, marked A, and the three sheets of drawings, marked B, C, and D, respectively, and which are hereunto annexed; and that he, the said Petitioner, hath deposited with the Honorable the Treasurer of the said Colony of New South Wales the sum of Twenty Pounds sterling, for defraying the expense of granting these Letters of Registration, as required by the Act of Council, sixteenth Victoria, number twenty-four; and hath humbly prayed that I would be pleased to grant Letters of Registration, whereby the exclusive enjoyment and advantage of the said invention or improvement might be secured to him for a period of fourteen years: And I, being willing to give encouragement to all inventions and improvements in the arts or manufactures which may be for the public good, and having received a report favourable to the prayer of the said Petition, from competent persons appointed by me to examine and consider the matters stated therein and to report thereon for my information, am pleased, with the advice of the Executive Council, and in exercise of the power and authority given to me by the said Act of Council, to grant, and do by these Letters of Registration grant unto the said Carson Woods, his executors, administrators, and assigns, the exclusive enjoyment and advantage of the said invention or improvement, for and during the term of fourteen years from the date hereof; to have, hold, and exercise unto the said Carson Woods, his executors, administrators, and assigns, the exclusive enjoyment and advantage thereof, for and during and unto the full end and term of fourteen years from the date of these presents next and immediately ensuing, and fully to be complete and ended: Provided always, that if the said Carson Woods shall not, within three days after the granting of these Letters of Registration, register the same in the proper office in the Supreme Court, at Sydney, in the said Colony of New South Wales, then these Letters of Registration, and all advantages whatsoever hereby granted, shall cease and become void.

In witness whereof, I have hereunto set my sign manual, and have caused the present Letters of Registration to be sealed with the seal of the said Colony of New South Wales, at Government House, Sydney, in New South Wales, this twenty-ninth day of June, in the year of our Lord one thousand eight hundred and eighty-three.

[L.S.]

AUGUSTUS LOFTUS.

*Improvements in Railway Cars or Waggon.*

SPECIFICATION of CARSON WOODS, of No. 253, George-street, Sydney, in the Colony of New South Wales, importer, the agent of Matthew Van Wormer, of Dayton, Ohio, one of the United States of America, the author or designer of an invention entitled "Improvements in Railway Cars or Waggon."

MY invention relates to improvements in that class of railway cars or waggons known as "dumping cars," which are capable of being tilted sidewise on their trucks to empty their loads in bulk.

The novelty of the invention consists in the construction and combination of the devices employed, as will be herewith set forth and specifically claimed.

In the accompanying drawings, figure 1 is a side elevation of my improved dumping car. Figure 2 is an end view of the same. Figure 3 is a plan view of the body taken off the trucks, and inverted. Figure 4 is a sectional end view, through the line  $x x$ , of figure 1. Figure 5 is a sectional side elevation, through the line  $y y$ , of figure 2.

The trucks A may be of the usual or any suitable construction.

Upon the top of each upper truck-timber at its middle is secured the centre body bearing plate B (shown at figure 6 in perspective). This plate is concave as represented, and has a central frusto-conoidal boss or extension  $a$ , through which the king-bolt passes down into the truck-timber, and serves to lock the plate B thereto. The head of the king-bolt  $b$  is shaped to complete the cone of which the boss upon the plate is a frustum as seen in figure 6. These plates B and their king-bolts form centre-bearings for the body of the car. Upon each side of the plate B, flat metal plates C, are secured to the upper truck-timber, and through each is one or more apertures, forming recesses  $c$ , whose office will be hereinafter explained.

Bolted to the side of each upper truck-timber in any suitable manner is a segmental rack, D, with the concave side uppermost as shown.

The platform or bed of my improved car-body is composed essentially, of the side beams E, end beams F, longitudinal central beams G, and traverse central transoms or beams H, supported by beams G.

Directly over each truck-timber is a rocker-piece I, flat on top and convex on its under surface, the whole forming the segment of an ellipse as represented. These rocker-pieces may be of wood, with the beams G mortised through them, and they are further supported by metal straps or plates J and K, of which the former passes over, and the latter under the rockers I, and have their outer ends, which are turned down, bolted to the side timbers E. While the under surfaces of the plate K are convex to conform to the rockers I, their outer ends are concave as represented, for a purpose to be hereinafter explained. To strengthen and stiffen this framework I employ the girder-rods  $f$ , as represented, and to form a further support for the bed planks, I use metal straps L, in pairs, which are bolted to the end timbers F, as represented, pass over the plates J and K, and over and under supporting-blocks secured upon the transverse beams H.

Securely bolted or otherwise fastened to the lower side of the rockers I, at their middle, are centre-bearing plates M, with convex lower surfaces, and having in each a central recess or aperture  $g$ , to receive and contain the heads of the king-bolts and the frusto-conoidal stem of the plates B. It is thus clearly seen that the body of the car, by the intervention of the plates M, rests upon the plates B, as central bearings, and at the same time the king-bolts and the stem of the plates B form pivots for each of the trucks while turning curves.

To dump the car on either side, I employ a central longitudinal shaft N, which is journaled in hangers  $h$ , supported by the beams G, and is further supported by passing through openings in the rockers I, and beams H. This shaft carries two pinions O, keyed to it, which engage respectively with each of the racks D. The teeth of the pinions are tapered at each side, so as to permit of the play between the parts requisite in turning curves. Keyed upon the end of the shaft N, just under the platform at one end of the car, is a worm wheel P, which engages with a worm R, secured upon a vertical shaft S, passing up through the platform, and provided with a crank or hand-wheel T. By turning said hand-wheel the shaft N is caused to rotate, and the car is tilted to either side desired. By the employment of this dumping gear with a worm shaft, a positive lock is always secured, no matter in what position the body of the car may be. It cannot move from that position without a breakage of some of the parts. To assist, however, in retaining the car in an upright position, and lessen the strain upon the dumping gear, I employ rests or side beams, U, which consist of cylindrical metal pieces carrying pivoted friction rollers  $i$ , in their lower ends as seen. These supports, figure 7, are recessed in metal sockets secured in the rockers I, on each side of the centre bearings, and are provided with laterally projecting pins  $j$ , which travelling in slots in the sockets prevent the supports from falling out of said sockets, and further prevent them from turning therein. These supports are sufficiently long also, that when dropped down to their lowest extent, their rollers  $i$  rest upon the plates C. To lock them in this position so as to enable them to support the body of the car, on each side I employ rods,  $k$ , having their forward ends connected to levers, W, which pivoted below the platform, pass up through openings in the same. Each of these rods,  $k$ , which are supported in the sockets, I, so as to slide therein, is provided with two slides, Z, of the shape represented, and so fitted into transverse openings in the rockers, I, adjacent to the support-sockets, that when said rods are shifted by their levers, the slides  $l$  will pass over the tops of the supports and prevent them from ascending into their sockets.

When it is desired to dump the car, it is only necessary to unlock the supports on the dumping side of the car, when by turning the hand-wheel as aforesaid, the car will turn and empty itself. During this tilting of the car, the supports or side bearings, which were unlocked, will be pressed up into their sockets out of the way, and will not interfere with the dumping. When the car, after being dumped, is turned back to a horizontal position, the supports will fall of their own gravity back to their former position, when they can be locked as aforesaid. In order to prevent the car while in the act of being dumped from being disengaged from its centre-bearings, I employ studs or dowels,  $m$ , which are secured in any manner desired to the under side of the rocker-plates, K, between the supports, U, and the centre bearings.

*Improvements in Railway Cars or Waggon.*

bearings. These dowels while the car is tilting, enter the apertures, *c*, in the plates, B, and serve to prevent the car from slipping or being displaced. The apertures, *c*, as seen, are sufficiently wide to receive the dowels even though the car when being dumped stood on a short curve.

Especial attention is called to the floor planks, X, which are raised as seen just over the rockers, for the purpose of enabling the car to be tilted over further without raising the bed higher than other cars of this class, or of ordinary cars. This result is further contributed to by the curved portion *p*, of the rocker-plates, K, and by the employment of the strap supports, L, which lying upon each other occupy very little space.

The sides of the car are moveable gates A<sup>1</sup>, which are held in slotted posts or supports B<sup>1</sup>, and these posts form journals for shafts C<sup>1</sup>, as seen. The gates A<sup>1</sup>, of which I employ two or more on a side, which are free to slide up and down in the slots of the posts, are connected to the shaft C<sup>1</sup> by chains, ropes, or wire cords D<sup>1</sup>, as shown.

By employing permanent or removable cranks at either end of the shafts C<sup>1</sup>, they may be rotated, thus winding up the chains D<sup>1</sup>, and causing the gates on either side to be raised simultaneously. A reverse motion would permit them to fall by their own gravity.

Another valuable feature of my invention consists of a director-board for causing the dumped material—as gravel for instance—to fall close to the rails of the track. This I accomplished by hinging a board E<sup>1</sup>, to the side beams by means of pivoted bracket-arms F, arranged as shown. By means of these swinging arms the board, when not wanted for use can be swung around so as to lie close to the side of the car, in which position the contents of the car would pass over it while being dumped; or it can be swung out as shown in figure 4, when it could act as a director to throw the load of the car close to the rails.

It will be observed that the dowels upon the under side of the rocker could be transferred to the plates C, and in that case the recesses *c* would be formed in the plate K of the rocker.

My invention further relates to the construction of the car-bed; to the transoms; to the construction of the rockers, and means whereby the car after dumping shall right itself up again; to a device for preventing the separation of the car-bed from the trucks; to the mechanism for dumping at either side of the car; to the means for fastening pulleys to the ends of the truck-timbers; to the mechanism for fastening and unfastening the doors of the car; to the construction of the doors; to the end posts and the means for fastening the same to the car-bed; to the centre posts and the means for fastening them to the car-bed; to the side bearings and their application, so as to keep the car-bed in position, and to prevent undue friction while the car is moving around curves of the track; in combining with the draw-bar a rocker, whereby the dumping may take place with the ordinary draw-bar without need of uncoupling the car from the other cars of the train; in an improved brake mechanism; in a special construction of clutch-pulley with grooves and sockets adapted to receive and hold the links of the chain, and whereby the revolving of the pulley to gradually tilt the car will operate the chain and prevent its slipping; in means for dumping either slowly or suddenly as desired; in a special construction of guide-rollers for the chains; in combining the shaft of clutch-coupling pulleys and their chain and its guide-pulleys, with a worm-gear or screw-lever for operating the same; and in other particulars hereinafter set forth.

In the drawings, figure 9 is an elevation of another improved dump-car; figure 10, a bottom view with one truck removed; figure 11, a cross-section through line *xx* of figure 10; figure 12, a top view of one of the trucks; figure 13, a plan of the couplers; and figure 14, a section through *yy*; figures 15 and 16, details of the draw-head and its rockers; figures 17 and 18, details showing the side bearings; figures 19 and 20, brake mechanism; figure 21, partial top view, parts being broken away, showing the coupler-pulleys and their connections; figure 22, fragment enlarged of convex stationary bed; figures 23, 24, 25, 26, and 27, details.

Of the timbers of the car-frame, 1, 1, represent cross-sills or headers extending from the longitudinal sills 2 and 5, and framed or secured into the same. 3 and 4 represent shorter sills framed into the cross-sill or header 1, and not as long as the outside sills 6, 7, or the sills 2, 5, the objects of making them shorter being for the purpose of giving space or room for the worm and gear of the screw-lever or other appropriate mechanism which operates the chain shaft hereinafter described, and also to allow sufficient space without weakening the car-bed for such bed to dump over the wheels, oil-boxes, and truck-timbers, without coming in contact with any of them.

An iron or wood transom 8, is applied to run above the top or upper portion of the sills of the car, and even with or above the top of the floor, and it may make a part of said floor; and other iron bars or wood transoms *a*, passing underneath the inside sills of the car and passing up in the shape of a brace between the respective outside sills 6, 7, and the sills 2, 5, are fastened to the transom 8, making a sufficient space between the lower sides of these transom-braces *a*, and the truck-timbers or truck-irons, to give the car-bed more and ample dumping room without coming in contact with such timbers or irons, or with the oil boxes, when discharging any material from the car. These transoms or braces *a*, also make the construction strong and safe.

The rockers and their arched beds are such that after dumping, the car-bed will right itself up again; and they are constructed as follows:—9 representing the rockers; their stationary convex beds being shown at 10; each may be all of iron or of iron and wood. The rockers 9, have each a short central downwardly-projecting stud or boss *b*, which may be of ball shape if desired; and also a series of stout strong cogs *cc*, on both sides of this stud; and the convex beds (see figures 11 and 22) have each a central shallow socket *c'*, to receive the stud or boss *b*, and also a series of sockets *c'' c''*, adapted to receive the cogs *cc*, the object of this being, that when the car is turned or dumped, they will prevent the car-bed from getting out of position, and at the same time permit the tilting of the bed far enough over and to a degree of pitch sufficient to discharge coal or other material without the risk of coming in contact with either the trucks, truck-irons, oil-boxes, or wheels, and also to permit the car to right itself up after dumping. The car or car-bed will automatically right itself after dumping, because when it is tilted or turned over to dump and is left free to return by disengagement of the V-shaped couplings on the shaft (or shafts) 12, hereinafter described, the fulcrum or bearing-point of the rocker is no longer at the boss *b* and

*Improvements in Railway Cars or Waggon.*

and its central socket, but has been shifted to one or more of the cogs and to their sockets, thus giving a long leverage for that side of the car or bed which is for the time being raised up, and this causes that side to fall by its own weight till the car is again level. It will be seen that any mechanical equivalent of these sockets, teeth, or cogs, and boss, which will allow the same action and result may be substituted for them. A bar of iron or wood represented at 11, is designed to hold the car-bed from separating from the trucks while the car is in transit or motion. It is bolted or fastened to the truck-timber, or to the lower convex bed, 10, and extends upward to be attached to either the upper rocker, 9, or to the car-bed, or to a cross-sill, and is provided with a bolt for connecting it to such part or to any iron or wood fastened thereto.

A shaft (or shafts if desired) marked 12, runs lengthwise of the car under its floor, either its full length or a sufficient distance for receiving at its end or ends coupling pulleys,  $e e^1$ , having V-shaped teeth on their adjacent sides for engaging with each other. On this shaft, 12 (if but one be used), are affixed permanently one near each end, and to revolve with it, two clutches,  $e$ , having V-shaped teeth as shown, designed each to be engaged or disengaged at will from its fellow, which is provided with similar V-shaped teeth, and placed loosely upon the shaft, and adapted to be shifted in or out of engagement with the fixed clutch,  $e$  (see enlarged views, figures 13 and 20). This coupling apparatus is to be located beneath the transom 8, so that the latter shall in no wise interfere with its free revolution. A chain,  $f$  (figures 9 and 10), passing over and clinging to the loose pulley,  $e^1$  (the particular construction of which pulley will be hereinafter fully described), and winding partly around said pulley, passes thence under guide-pulleys  $g g$ , adjustable if desired, secured to the rocker or to the timbers of the car-bed. This chain also passes under guide pulleys  $h h$  (see figures 9, 12, and 25), attached respectively to the opposite ends of the truck-timbers or frame; thence the ends of the chain respectively pass up to and are fastened upon the car-bed, or upon the outside sills, 6, 7, or to the car-floor.

For the purpose of applying the pulleys  $h h$ , to the outer ends of the truck-timbers so as not to interfere with the proper action of the car-springs, I fasten to the end of the under truck-timber a strap or bar  $i$  (see figure 25), of wood or iron, and connect it to the upper truck-timber by bolts extending into or through such truck-timber, and through a slot in said strap or bar,  $i$ , such slot allowing the springs between the two truck-timbers to work the same as though said strap or bar were not there. The slot may be in either end of the bar,  $i$ . Another strap or bar,  $i^1$ , of iron (or of wood), is bolted to the lower end of the bar  $i$  (or to the truck-timber, to which it is firmly attached), and extends outward sufficiently to admit the pulley  $h$ , between the bars  $i$  and  $i^1$ , the axis or journal of said pulley  $h$ , being supported by the two straps  $i i^1$ .

I will now describe the manner and the means of fastening and unfastening the doors automatically.

A bar or rod of iron 15, fastened or suspended to the outside sills respectively of the car, have thereon one or more dogs or levers,  $k$  (see figure 11), and to the outer ends of such levers are pivoted one or more upright slides or latches,  $l$ , adapted to extend a little above the floor of the car, sufficient to catch, latch, and hold down the swinging doors 16, which latches run in appropriate guides or staples  $m$ . The levers,  $k$ , are constructed that when the car is being dumped their long arms will come in contact with or strike the truck-timber or truck-irons at the appropriate time, and unlatch the doors 16. Each latch,  $l$ , is provided with a hole in which a pin,  $n$ , may be inserted to lock them when desired. When these pins are removed the latches are ready for their automatic action upon tilting the car, as above stated.

Each door, 16 (see figure 9), is a batten-door, mortised in timbers or iron,  $o$ , at each end, and swinging on pivots at their upper ends. These doors are supplied with and strengthened by metal cross-bars or straps,  $p$ , secured thereto, the lower ends of which are so bevelled or turned under at an incline as to allow them readily to pass the upper bevelled ends of the latches,  $l$ , in the act of closing the doors. The weight of the levers,  $k$ , tends to throw up the latches,  $l$ , and to automatically fasten the doors when they shall have passed the latches. One or more straps,  $q$ , of wood or iron, fastened on the outside of the door, and extending below its lower line serves to prevent the door from swinging too far in. The door is also provided with one or more truss-rods,  $r r^1$ , either inside or out, or both, for the purpose of strengthening it and holding it properly to place.

The upright end posts, 17, of the car, and their connections are as follows:—They rest, respectively upon the outside sills, 6, 7, and extend down on the side thereof a sufficient distance to admit of being strongly secured thereto by bolts or otherwise, and extend far enough above the doors to permit the same to be hinged or attached thereto. Said posts, 17, are grooved or recessed on their inner corners (see figure 23) to receive the end board of the car so as to leave the inner face of the said board or plank flush or even with the inside of the post, thereby preventing any obstruction when unloading, and also to make the car more firm and strong. A rod,  $s$ , of metal or wood, extends across the end of the car and through both these posts to hold them and the end plank or board,  $t$ , firmly in their places. There is also an iron or wooden brace,  $u$ , extending from each post to the end sill or floor to aid in bracing and holding said post, 17, to its place. The upright centre posts, 18, also rest and are secured respectively upon the outside and top of a sill, and each is further secured by a metal plate,  $w^1$ , which extends down, and is fastened to the inside of the outside sills of the car as seen in figure 24. A metal rod,  $v$ , passes through both these opposite centre posts, 18, 18, under the floor and above the sills, and is tightened by appropriate nuts or equivalent means for firmly holding the posts in place.

The side bearings for holding the car, and keeping it in position, are represented at 19, in figure 11, and in an enlarged view in figures 17 and 18, and are as follows:—They severally consist of a bar of iron or wood adapted to rest on the truck-timber, and extending upwards, and moveably secured to the rocker, or to the sills, or transoms, or floor of the car. Through a hole,  $x$ , having a slot or key-way,  $y$ , in the upper end of each side bearing, passes a shaft or bolt,  $z$ , with a key or pin,  $a^2$ , thereon. This shaft is secured to the car as above-named. It is represented in the drawings as attached to an end of the rocker. This slot,  $y$ , allows the side bearing to play at its upper end and thus prevent that friction which it would otherwise have if compelled to travel or move rigidly upon the truck-timber when the car is moving around curves.

The outer end of the shaft or bolt,  $z$ , receives an arm,  $b^3$ , secured to it by a pin or screw for the purpose of permitting the said shaft and bearing to be moved by appropriate connections extending upwards

*Improvements in Railway Cars or Waggon.*

upwards and connecting with a rod,  $e^2$ , which extends and is attached to both side bearings on one side of the car on the front and rear trucks, said rod extending to the end of the car, and being there attached to a lever,  $f^2$ , for the purpose of operating both side bearings, which are upon one side of the car, at one act by the same lever, to allow the dumping. Similar side bearings and attachments are on the other side of the car.

On the under side of each draw-bar, 20, is an arched or curved rocker, 20\*, the object of which is to permit the car to be tilted for dumping or otherwise, without the need of uncoupling any car from the other cars of the train (see figures 15 and 16). This rocker may rest on a curved bed, as shown in figure 8.

I will now describe my improved brake mechanism, consisting of a combination of levers, chains, and pulleys, as follows: referring more particularly to figures 12 and 25. A bar, 21, of metal or wood, attached to the truck-timber by an arm, 22, and bolts or screws, is also attached to the brake rod or bar,  $f^2$ , by an arm, 23, and bolts or screws. The two brake-bars of each truck act coincidentally upon the inner perimeter of all the wheels of each truck by means of the following connections:—This bar or lever, 21, which is connected to and immediately operates one end of the brake-bars, and which as above stated, is fulcrumed upon the lower truck-beam, is also connected by means of a rod or bar,  $r^2$ , with one end of a lever,  $j^2$ , at the opposite of said truck-beam, the other end of said lever connecting with the other brake-bar,  $g^2$ , which acts upon the other two wheels of the same truck, thus giving a movement in opposite directions at the same time to the two brake-bars. Provision is made for adjusting the throw of the levers which actuate the brakes. The brakes and their bars are suspended by links  $k^2$   $k^2$ , from springing or yielding straps,  $l^2$ , secured upon the truck-beams. This affords a yielding and play to meet varying exigencies, and a self adaptation to the curvature of the wheel.

To the upper end of bar, 21 (see figures 19 and 20), is attached a chain (or a rod) which connects with a lever,  $m^2$ , one end of said lever being fastened to the sill or floor of the car, as shown at  $n^2$ , and the other end being connected to a chain (or rod)  $o^2$ , running in a direction lengthwise of the car, such chain passing around a pulley,  $p^2$ , on or near the end of the car, and fastened at its extremity to an upright hand-lever, which lever is pivoted to the sill, or below the sill of the car. By operating this lever the brakes are brought into action, and the lever may be held to any desired position by means of a rack or ratchet,  $r^2$ , with the teeth of which it may engage and be held.

The loose coupling-pulley,  $e^1$ , has cavities on its periphery precisely adapted to receive and hold positively therein the successive links of the chain,  $f^1$ . These cavities may be described as follows, in general terms:—A series of oval-shaped depressions or sockets,  $s^2$  (see figures 13 and 14), to receive those links which lie flat; such oval sockets communicating only by deep narrow cuts or grooves,  $s^3$ , sufficient to receive edgewise those links which connect the alternate flat-lying ones. Each flat-lying link is sunk below the periphery of the pulley or wheel. A pull upon the chain would therefore revolve the wheel. Consequently the revolution of this coupling-pulley,  $e^1$ , must positively and without any chance of slipping pull the chain in the direction of its revolution, and thereby tilt the car. The chain being properly applied in the first instance, with sufficient slack at its opposite ends to permit the greatest degree of tilting ever required, this proper relation is always under control. The chain is thus always self-holding to its pulley and can never slip, although the chain is as it needs to be for this purpose, a loose one.

For connecting and disconnecting these couplers  $e^1$ , there is an annular groove,  $e^4$ , around the periphery of the loose pulley  $e^1$ , into which projects a pin upon a shifting-lever, 24 (see figure 21), pivoted to a rod,  $w^2$ , extending lengthwise of the car, for operating both couplings, if desired; said rod being actuated by means of a hand-lever at the end of the car or other convenient place. When, by means of this lever, the couplings are disengaged or uncoupled, the pulley  $e^1$ , may revolve suddenly as a loose pulley, in order to allow the car-bed to discharge its load itself, when it will come back or return of itself to its upright position. When the coupling-pulleys are coupled or engaged, then the car may be tilted slowly. This capacity for sudden dumping is important when clay, damp coal, or other damp or adhesive material constitutes the load, so as to discharge it with a jar or "thud," but with other materials which might be damaged by such jars or shocks, or when it is desired to deliver gradually, the V-couplings when in engagement afford full control to tilt the car as far, or as slowly, as may be advisable.

The guide-pulleys,  $g$ , for the chain,  $f$ , are hexagonal on their peripheries, thus presenting six flat surfaces of a size adapted to the flat lying links of the chain, and a peripheral groove,  $x^2$ , adapts them for receiving the intermediate or edgewise-lying links (see enlarged view, figure 27). Thus these pulleys fit all the surface of the chain, and prevent its getting off. They may be flanged, also, if desired. Instead of being hexagonal, these pulleys may have eight or more peripheral faces. The pulleys,  $h$ , are circular, but with an annular groove to receive the edges of alternate links of the chain.

Having thus fully described my invention, what I claim is—

First—In a dumping-car, the combination of following instrumentalities: segment-racks attached to the trucks, pinions engaging with said racks attached to the car-body by a common shaft and an actuating worm-shaft connected to the pinion shaft by a worm-wheel, whereby the car can be dumped to either side, and whereby a positive lock is effected between the car-body and trucks, no matter in what position of inclination the car-body may stand.

Second—In a dumping-car, the combination with rockers upon which the car-body turns and rests, of central bearing-pivots, consisting of concave plates, B, with frusto-conoidal stems and king-bolts, whose heads complete the cones of which the plate-stems are frustums, as specified.

Third—In a dumping-car, the combination with the trucks, whose upper-timbers are provided with central bearings and pivots, and flat metal bearing-plates, of convex rockers attached to the body of the car, and mounted upon said central pivots and bearing plates, as specified.

Fourth—In a dumping-car, the rockers I, carrying upon their under surfaces the reversed curved metal plates K, and the central recessed convex bearing-plates M, in combination with the subjacent concave plates B, and their conical pivots, substantially as specified.

Fifth—



*Improvements in Railway Cars or Waggon.*

- Fifth—In a dumping-car, the combination with rockers upon which the body turns and rests, and by which it is pivoted to the trucks, of telescopic gravitating side bearings, whereby when said side bearings are extended and locked, the car-body is prevented from turning to either side, as specified.
- Sixth—In a dumping-car, the combination with the rockers I, of the side bearings or supports U, recessed in sockets in said rockers, and carrying at their lower ends friction rollers, as and for the purposes specified.
- Seventh—In a dumping-car, the combination with the telescopic gravitating side bearings or supports U, of locking-slides connected to shifting rods actuated by levers upon the platform, whereby upon moving said levers in one direction, said side bearing are locked to enable them to support the body of the car and prevent it from tilting, and whereby upon moving said levers in an opposite direction, said side bearings are unlocked and will permit the car to be dumped by ascending into their sockets, as specified.
- Eighth—In a dumping-car, the combination with the rockers I, and recessed plates C, of dowels or studs connected to the lower side of said rockers, and adapted to enter the recesses in the plates to prevent the body of the car from slipping or becoming displaced when dumped, as specified.
- Ninth—The herein described construction of the car-bed or body, consisting of the side beams E, end beams F, longitudinal central beams G, transverse central transoms H, girder-rods *f*, and strap-braces L, the whole constructed and united in the manner and for the purpose specified.
- Tenth—The vertically rising and lowering gates A<sup>1</sup>, in combination with actuating-shafts C<sup>1</sup>, connected thereto by chains, ropes, or cords, as specified, whereby upon rotating said shafts, the gates on either side are raised or lowered simultaneously.
- Eleventh—In a dumping-car, the bed or platform raised transversely across and above the trucks, whereby the car can be turned over further without raising the main body of the car higher than ordinary cars, substantially as described.
- Twelfth—In a dumping-car, the directing or deflecting board, hinged to the side of the car by swinging brackets, substantially as shown and described.
- Thirteenth—The car-bed as made with the cross sills and headers, 1 1, extended from the longitudinal sills, 2 5, and which reach from end to end of the car, and framed or fastened thereon, and with the shorter longitudinal sills, 3 4, framed into the headers, 1 1, and with the outside sills, 6 7, the construction affording space at the ends of the car and between the sills, 2 5, for the worm and gear of machinery which operates the dumping mechanism, and ample clear space at the sides for dumping, and all without weakening the car-bed.
- Fourteenth—The rocker, 9, constructed with a short central round boss, *b*, and with a series of stout cogs, *c c*, on its under side, in combination with the convex bed, 19, constructed with the shallow central socket, *c*<sup>1</sup>, and the sockets, *c*<sup>2</sup> *c*<sup>2</sup>, on its upper side, adapted for the cog-teeth, *c c*, all as shown and described, and for the purpose of dumping the car and of permitting it to right itself up again.
- Fifteenth—The dumping shaft or shafts, 12, extending nearly the length of the car, in combination with the clutch-pulley thereon, and with the linked chain and the described series of pulleys or devices for actuating the same, and for connection with a hand-lever or wheel, and a connecting worm and gear whereby such shaft may be operated to dump either slowly or suddenly at option.
- Sixteenth—The combination with the ends of the truck-timbers of the straps, *i*<sup>1</sup> *i*<sup>1</sup>, and their interposed guide-pulley, *k*, these straps being constructed and applied to each other and to the truck-timbers, substantially as set forth, so as not to interfere with the proper action of the car springs.
- Seventeenth—In combination with the swing-doors, the bar or rod, 15, one or more dogs or levers, *k*, beneath the car, one or more vertical slide latches, *l*, and their guides, the combination and arrangements being such that the inner end of the dogs, *k*, may serve automatically to fasten or to unfasten the doors in the manner shown and described.
- Eighteenth—The swing-doors constructed as described, that is to say: mortised in timbers or iron supports, *o*, at each end, strengthened by truss rods, *r r*, and by metal cross-bars or straps, *p*, having bevelled lower ends for engagement with the fastening-latches and provided with one or more straps or projections, *q*, as and for the purposes set forth.
- Nineteenth—In combination with the car-bed, the end posts, 17, resting on the outside sills, and extending down and secured to the outside of the same, and extending high enough to permit the swing-doors to be attached thereto, said posts being grooved or recessed at their inner corners to receive the end board, *t*, of the car flush with the inside of the posts, the posts and the board being held together by a connecting-rod, and braced by braces, *u*, all substantially as shown and described.
- Twentieth—The centre posts, 18, made and applied to the car-bed, as described, and assisting to support the swing-doors, and strengthened by an inside metal plate, *u*<sup>1</sup>, and by a tightening-rod, *v*, beneath the floor connecting the two opposite posts.
- Twenty-first—In combination with the car, the moveable side-bearings, 19, provided at their point of suspension with a slot or keyway, as described, whereby while holding the car in position during transit, and adapted to be swung up for dumping, they also prevent undue friction when the car is in motion around curves.
- Twenty-second—In combination with the draw-bar, the rocker or arched piece, 20\*, secured upon its under side, as and for the purpose described.
- Twenty-third—In combination with a dumping-car, brake mechanism, as described, consisting of the combination of bar 21, arm 22 on the truck-timber, arm 23, brake-bars *f*<sup>2</sup> *g*<sup>2</sup>, rod or bar *i*<sup>2</sup>, lever *j*<sup>2</sup>, links *k*<sup>2</sup>, and yielding straps *l*<sup>2</sup>, and appropriate means for actuating the same from the car platform.
- Twenty-fourth—



*Improvements in Railway Cars or Waggon.*

Twenty-fourth—In combination with a dumping-car, the pulley  $e^1$ , made integral with its deep sockets  $s^2$ , and their narrow connecting-grooves, and with the V-teeth and the annular groove, as and for the purposes set forth.

Twenty-fifth—In combination with a dumping-car, the pulley-shaft, the loose pulley  $e^1$ , made integral with its deep sockets and connecting-grooves, V-teeth, and annular groove, as set forth, the pulley  $e$ , and appropriate mechanism for disengaging these pulleys, and to allow the car-bed to dump its load suddenly or slowly, as desired.

Twenty-sixth—In combination with a dumping-car, and with the pulley-shaft, its fixed pulley  $e$ , and the loose pulley  $e^1$ , made integral with its sockets, grooves, V-teeth, and annular groove, the shifting-lever  $24$ , rod  $u^2$ , and hand-lever  $v^2$ , these devices operating as and for the purposes described.

Twenty-seventh—In combination with the linked chain  $f$ , attached to both sides of the car-bed, the guide-pulleys  $g$ , made with the flat surfaces  $w^2$ , adapted for the links, and with the peripheral groove  $x^2$ , as shown and described.

Twenty-eighth—In a dumping-car, the combination with the pulley-shaft and with the described mechanism for operating the same, and of the pulley  $e$ , the pulley  $e^1$ , made integral with its sockets, connecting-grooves, V-teeth, and annular groove, the linked chain, guide pulleys  $g$ , grooved as described, and the guide pulleys  $h$ , made as described, the ends of the chain being fastened to the outside car-sills or floor, all substantially as shown and described.

In witness whereof, I, the said Carson Woods, have hereto set my hand and seal, this  
day of                    one thousand eight hundred and eighty-three.

CARSON WOODS.

Witness—

FRED. WALSH,

Manager Edward Waters' Patent Office, Sydney.

This is the specification, marked A, referred to in the annexed Letters of Registration granted to Carson Woods, this 29th day of June, A.D. 1883.

AUGUSTUS LOFTUS.

## REPORT.

Sir,

Sydney, 14 May, 1883.

Replying to your B.C. of 1st instant, covering a Petition from Mr. Carson Woods, of Sydney, for Letters of Registration for an invention entitled "Improvements in Railway Cars or Waggon," we have the honor to inform you that having examined the drawings and specification accompanying the Petition, we recommend that Letters of Registration be granted to the Petitioner for the invention in question, as shown in the drawings and described in the specification before referred to.

We have, &amp;c.,

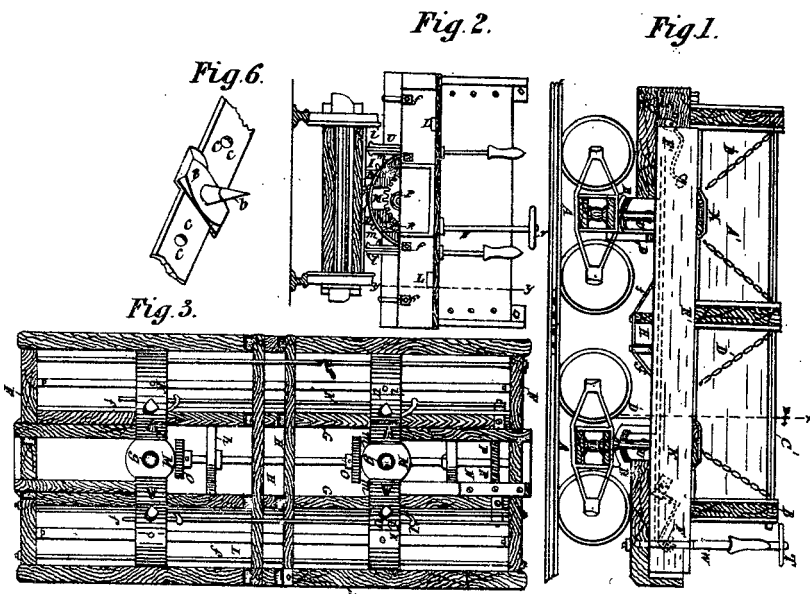
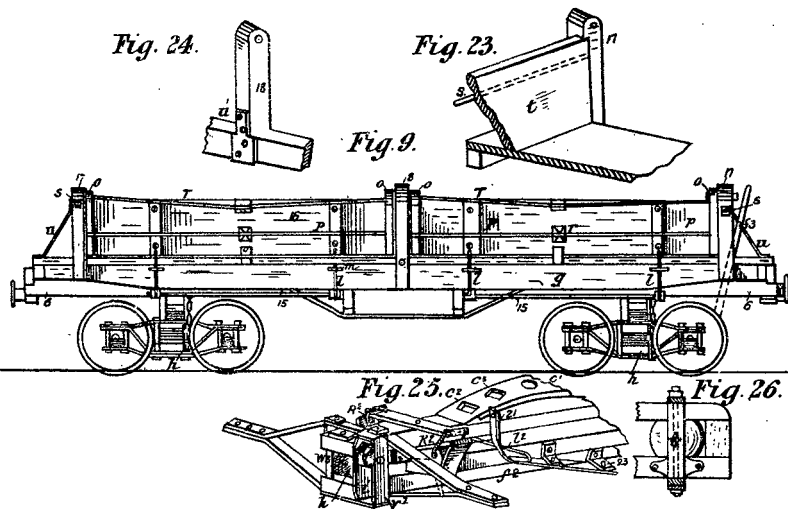
JOHN WHITTON.  
E. O. MORIARTY.

The Under Secretary of Justice.

[Drawings—three sheets.]

B.

1270.



*This is the Sheet of Drawings marked B. referred to in the annexed Letters of Registration granted to Carson Woods, this 29<sup>th</sup> day of June A. D. 1883.*

*Augustus Loftus.*

(Sig. 35.)

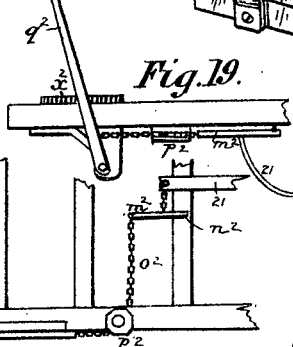
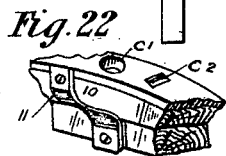
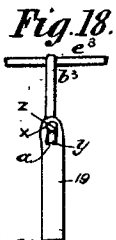
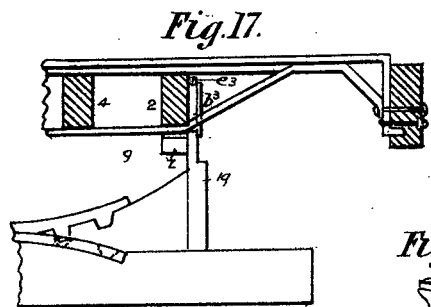


Fig. 20.

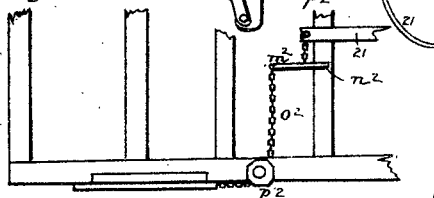


Fig. 21.

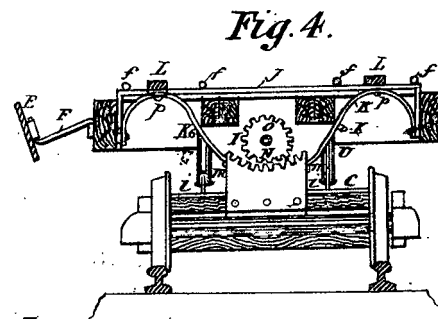
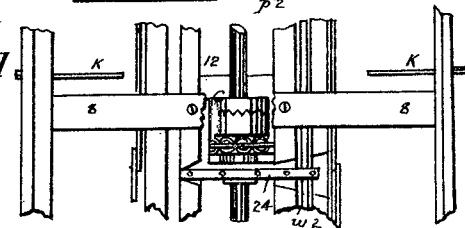


Fig. 4.

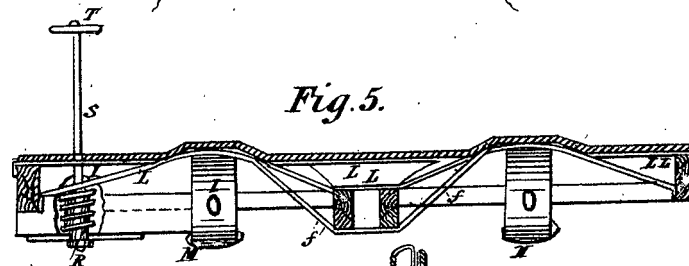
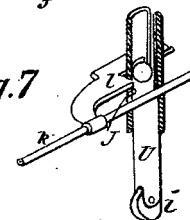
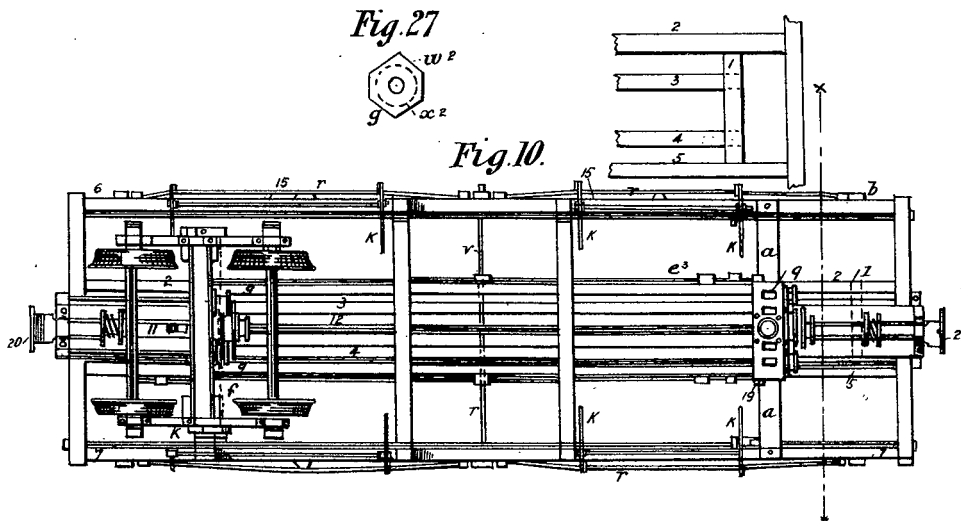
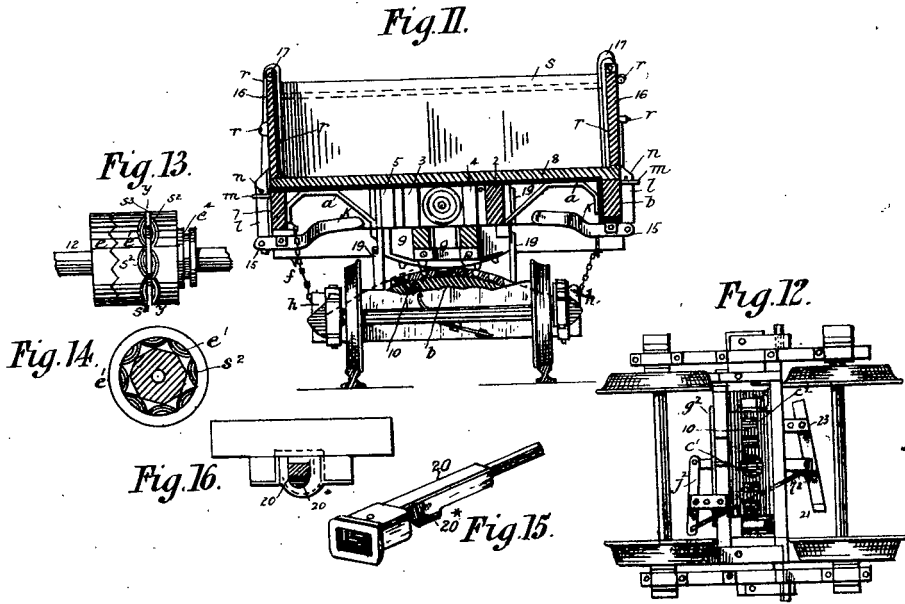


Fig. 5.

Fig. 7.



*This is the Sheet of Drawings marked C. referred to in the annexed  
 Letters of Registration granted to Carson Woods, this 29<sup>th</sup> day  
 of June A. D. 1883.  
 Augustus Loftus.*



*This is the Sheet of Drawings marked D. referred to in the annexed Letters of Registration granted to Carson Woods this 29<sup>th</sup> day of June A. D. 1883.*

*Augustus Loftus.*



A.D. 1883, 3rd July. No. 1271.

IMPROVEMENTS IN WOOL-WASHING MACHINES.

LETTERS OF REGISTRATION to William Wilkinson for Improvements in Wool-washing Machines.

[Registered on the 4th day of July, 1883, in pursuance of the Act 16 Vic. No. 24.]

BY HIS EXCELLENCY THE RIGHT HONORABLE SIR AUGUSTUS WILLIAM FREDERICK SPENCER LOFTUS (commonly called LORD AUGUSTUS LOFTUS), Knight Grand Cross of the Most Honorable Order of the Bath, a Member of Her Majesty's Most Honorable Privy Council, Governor and Commander-in-Chief of the Colony of New South Wales and its Dependencies.

TO ALL TO WHOM THESE PRESENTS SHALL COME, greeting :

WHEREAS WILLIAM WILKINSON, of Brunswick-street North, Fitzroy, in the Colony of Victoria, woolsorter, hath by his Petition humbly represented to me that he is the author or designer of a certain invention or improvement in manufactures, that is to say, of an invention entitled "Improvements in Wool-washing Machines," which is more particularly described in the specification and drawing which are hereunto annexed; and that he, the said Petitioner, hath deposited with the Honorable the Treasurer of the said Colony of New South Wales the sum of Twenty Pounds sterling, for defraying the expense of granting these Letters of Registration, as required by the Act of Council, sixteenth Victoria, number twenty-four; and hath humbly prayed that I would be pleased to grant Letters of Registration, whereby the exclusive enjoyment and advantage of the said invention or improvement might be secured to him for a period of fourteen years: And I, being willing to give encouragement to all inventions and improvements in the arts or manufactures which may be for the public good, and having received a report favourable to the prayer of the said Petition, from competent persons appointed by me to examine and consider the matters stated therein and to report thereon for my information, am pleased, with the advice of the Executive Council, and in exercise of the power and authority given to me by the said Act of Council, to grant, and do by these Letters of Registration grant unto the said William Wilkinson, his executors, administrators, and assigns, the exclusive enjoyment and advantage of the said invention or improvement, for and during the term of fourteen years from the date hereof; to have, hold, and exercise unto the said William Wilkinson, his executors, administrators, and assigns, the exclusive enjoyment and advantage thereof for and during and unto the full end and term of fourteen years from the date of these presents next and immediately ensuing, and fully to be complete and ended: Provided always, that if the said William Wilkinson shall not, within three days after the granting of these Letters of Registration, register the same in the proper office in the Supreme Court, at Sydney, in the said Colony of New South Wales, then these Letters of Registration, and all advantages whatsoever hereby granted, shall cease and become void.

In witness whereof, I have hereunto set my sign manual, and have caused the present Letters of Registration to be sealed with the seal of the said Colony of New South Wales, at Government House, Sydney, in New South Wales, this third day of July, in the year of our Lord one thousand eight hundred and eighty-three.

[L.S.]

AUGUSTUS LOFTUS.

*Improvements in Wool-washing Machines.*

SPECIFICATION of WILLIAM WILKINSON, of Brunswick-street North, Fitzroy, near Melbourne, in the Colony of Victoria, woolsorter, for an invention entitled "Improvements in Wool-washing Machines."

THIS invention relates to tank wool-washing machines, and consists first and principally in a certain novel description of agitator for agitating the wool while it is passing through the tank; second, in a certain novel description of harrow, to be used as a substitute for the ordinary fork in carrying the wool through the water; and third, in a novel construction of the tank itself so as to permit of the separation of the shoddy or short wool from the good, long wool.

My novel description of agitator consists of rows of long teeth or arms proceeding upward from a series of horizontal shafts passing across the bottom of the tank at regular intervals, and to which a double rocking motion is imparted for every single forward motion of my harrow, between the teeth of which my agitators swing or rock to and fro.

My substitute for the ordinary fork consists of what I call a harrow, because it has a number of long teeth descending from a framing, which is carried at each end by a double crank-shaft, supported in bearings on the sides of the tank. Each such harrow is divided into two halves lengthwise, as by reason of the double crank in the shaft one half or side is down while the other is up.

My novelty in the construction of tanks is to make them double, that is to say, with an inner and an outer tank, the inner one being perforated at its bottom and sides. The bottom of this inner tank only acts as an equivalent for the ordinary perforated false bottom, but the perforations in the side allow of the escape of the short wool or shoddy into the space between the two tanks, where it floats on the surface of the water, and can be removed as often as is found convenient.

Referring to my drawings, figure 1 is side elevation, partly in section, of a wool-washing machine constructed according to my invention; and figure 2 is a top view; figure 3 being section on the line *a a* in figure 2. Figure 4 is an enlarged view, showing connections for working the agitators, and figure 5 represents, full size, a portion of the side of the inner tank, showing the perforations in it. The perforations in the bottom are larger.  $A^1$ ,  $A^2$ , and  $A^3$  are the three tanks, to the first of which none of my improvements are attached. In  $A^2$  and  $A^3$ , however, my improvements are clearly illustrated, thus my novel agitators are marked B, and my novel harrows are marked C. Each row of agitators is connected to a shaft  $B^1$ , working in bearings  $B^2$  on the inner side of the outer tank. These shafts move simultaneously by means of cranks  $B^3$ , being worked by connecting-rod  $B^4$  (attached to them all), which derives its motion from crank  $B^5$ , keyed on to one of the shafts made to project outside the outer tank, and which is driven by eccentric-rod  $B^6$ , attached to eccentric  $B^7$ , on the main driving shaft D.

Each harrow is supported on two double crank-shafts  $C^1$ , which are driven by bevel-gearing  $C^2$ , from shaft  $C^3$ , which is itself driven by other bevel-gearing  $C^4$ , from roller-shaft  $C^5$ .

Referring to the other parts of the machine illustrated, I desire to observe that in the first or soak tank  $A^1$  there is nothing novel. It has no inner tank, but only the ordinary perforated false bottom. E is an ordinary fork attached to a crank-shaft  $E^1$ , driven by belt  $E^2$  from pulley  $E^3$  on main shaft D.  $E^4$  is a movable stay pivoted at  $E^5$ , adjustable by nut and screw  $E^6$ .  $E^7$  is a second pulley on crank-shaft  $E^1$ , a belt from which F drives a pulley  $F^1$  on end of another crank-shaft  $F^2$ , which carries another ordinary fork  $F^3$ . On said crank-shaft  $E^1$  is a third pulley (inside the tank  $A^1$ ), a belt from which G drives a fan or blower  $G^1$ . H H H are ordinary creepers for carrying the wool between the rollers J and  $J^1$ , the lower one being driven by bevel-gearing  $J^2$  from shaft  $C^3$ , and K K are ordinary rollers for assisting in the removal of any wool which may adhere to the lower rollers  $J^1$ . The third fork M is driven by belt  $M^1$ , passing over pulley on main shaft D and crank-shaft  $M^2$ , which carries the fork M. L is a large fan at the end of the machine for blowing the wool discharged by the final rollers clear of the machine.  $J^2$  and  $J^3$  are levers and weights for adjusting the pressure on the rollers J and  $J^1$ .

The mode of operation is as follows:—The wool to be washed is first soaked in tank  $A^1$ , as is now commonly the case, and from thence it is delivered by fork E on to creeper H, from whence it passes between rollers J and  $J^1$ , and is delivered into tank  $A^2$ , the fan or blower  $G^1$ , the cleaning roller K, and a water jet, not shown, combining to clean the roller  $J^1$ , and direct the wool into the second tank  $A^2$ . This tank, as well as the next one,  $A^3$ , are constructed on my novel principle of being double, that is to say, with an inner perforated tank contained in an outer plain tank. The wool is discharged from the rollers into my inner tank, and is almost immediately taken hold of by my agitators B, which carry it to and fro in the water and to and fro a second time before my harrows C come into play. These then carry it along a certain distance, and then my agitators come into play again, and repeat their previous performance until the wool escapes from them and is subjected to a jet of water just behind the second lifting fork  $F^3$ . The effect of this jet of water at this point of the process is to separate the grass seeds and the short or shoddy wool from the good, long staple. This shoddy floats on top of the water, and is carried through the perforations in the sides of the inner tank into the space between it and the outer tank, the long staple wool being then carried by fork  $F^3$  on to second creeper H, which carries it between a second set of squeezing rollers and into tank  $A^3$ , in exactly the same manner, and subject to exactly the same treatment, as in tank  $A^2$ , the short or shoddy wool being driven off a second time by a third jet of water just behind the last fork, and carried, as before, through perforations in the sides of the inner tank to the space between it and the outer tank, the good, long staple wool being finally lifted by fork M on to the last creeper H, and discharged through the end rollers J and  $J^1$ , from whence it is blown away by fan L.

Of course there may be many modifications of my invention without departing from its essence or principle; for instance, my agitators may be made longer or shorter; they may be moved more or less frequently, and by other mechanical devices than I have shown; and the harrows may also be made as one whole instead of in two parts lengthwise, and then the shafts which carry them would have to be only singly cranked instead of doubly cranked; and the inner tank may be smaller relatively to the outer one than I have shown it; and the perforations more or less numerous and of varying size; although in all these particulars I have shown and described that which I believe to be the best. The main principle of the invention is the use of agitators or long teeth, which move between other long teeth, and

*Improvements in Wool-washing Machines.*

and the best and most effective method of applying this principle is to make the agitators work between the long teeth of the harrows, as I have shown them. An inferior method is to reverse these contrivances, and put the agitators above and the harrows below. Another inferior method is to make the machine as I have shown it, save and except putting the agitators in a fixed position at an opposite angle to that shown in the drawings.

Having thus described the nature of my invention, and the manner of performing same, I would have it understood that what I believe to be novel, and therefore claim as my improvements in wool-washing machines, are:—

First—The combination of two sets of long teeth, pointing towards each other, and so arranged in the washing tanks as that one set passes between those of the other set, and preferably in the manner set forth in my drawings.

Second—Imparting to my agitators B a double to and fro rocking motion for each forward motion of my harrows.

Third—The special construction of harrows for wool-washing machines, made in two halves lengthwise, as shown in my drawings, each consisting of a number of long teeth or arms joined to a framing carried by two double crank-shafts, by which the necessary motion is imparted to them.

Fourth—I also claim, as a modification of such harrows, the making of them as one whole (and not in two halves), carried and worked by two single cranked shafts (and not by two double cranked ones).

Fifth—The construction of wool-washing tanks double, the inner one being perforated at its bottom and sides, and leaving a space between it and the outer one, substantially as herein described and as shown in my drawings.

In witness whereof, I, the said William Wilkinson, have hereunto set my hand and seal, this first day of May, one thousand eight hundred and eighty-three.

WM. WILKINSON.

Witness—

EDWD. WATERS,  
Melbourne, Patent Agent.

This is the specification referred to in the annexed Letters of Registration granted to William Wilkinson, this third day of July, A.D. 1883.

AUGUSTUS LOFTUS.

---

REPORT.

---

Sir,

Having examined the specification and plans accompanying the Petition of Mr. William Wilkinson for an invention entitled "Improvements in Wool-washing Machines," we are of opinion that the prayer of the Petitioner may be granted.

Sydney, 30 January, 1884.  
We have, &c.,  
JAMES BARNET.  
THOS. RICHARDS.

The Under Secretary of Justice.

---

[Drawings—one sheet.]

— WILKINSON'S PATENT WOOL WASHING MACHINE. —

FIG 1

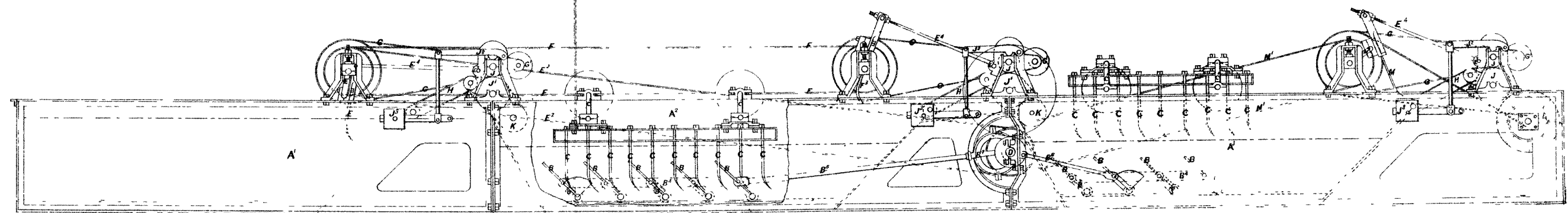


FIG. 2.

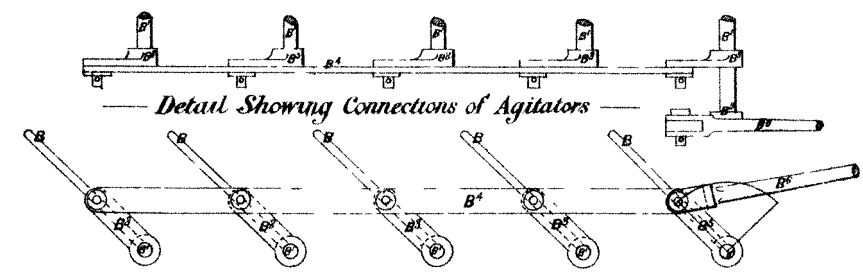
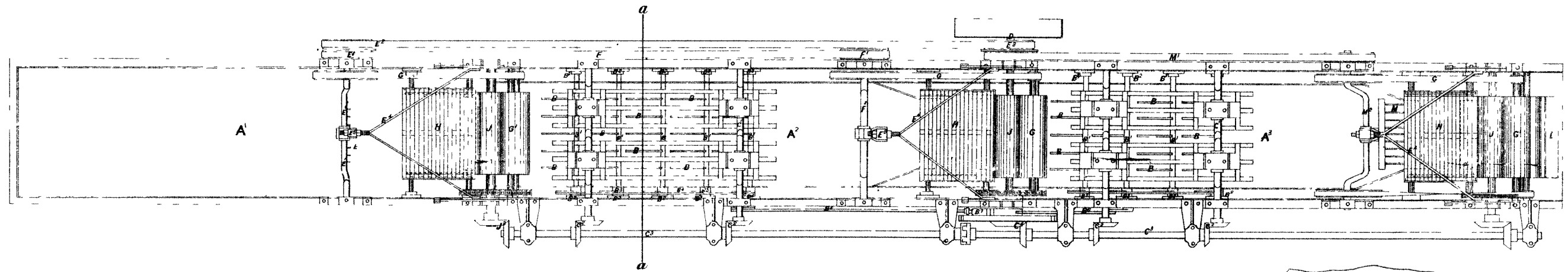


FIG. 4

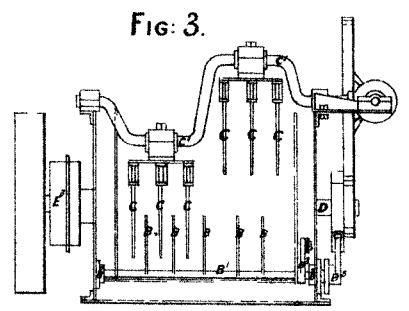


FIG. 3.

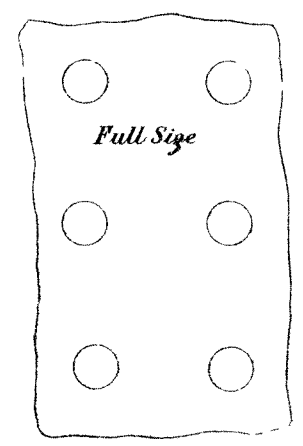


FIG. 5.

*This is the Sheet of Drawings referred to in the annexed Letters of Registration granted to William Wilkinson, this third day of July, A.D. 1883.*  
*Augustus Loftus.*





A.D. 1883, 3rd July. No. 1272.

HYDRAULIC IMPROVEMENTS IN CLOSING DOORS AND SHUTTERS.

LETTERS OF REGISTRATION to Norman Selfe, for Hydraulic Improvements in Closing Doors and Shutters.

[Registered on the 3rd day of July, 1883, in pursuance of the Act 16 Vic. No. 24.]

BY HIS EXCELLENCY THE RIGHT HONORABLE SIR AUGUSTUS WILLIAM FREDERICK SPENCER LOFTUS (commonly called LORD AUGUSTUS LOFTUS), Knight Grand Cross of the Most Honorable Order of the Bath, a Member of Her Majesty's Most Honorable Privy Council, Governor and Commander-in-Chief of the Colony of New South Wales and its Dependencies.

TO ALL TO WHOM THESE PRESENTS SHALL COME, greeting :

WHEREAS NORMAN SELFE, of 141, Pitt-street, in the city of Sydney, and Colony of New South Wales, gentleman, hath by his Petition humbly represented to me that he is the author or designer of a certain invention or improvement in manufactures, that is to say, of an invention entitled, "Hydraulic Improvements in Closing Doors and Shutters," which is more particularly described in the specification and drawing which are hereunto annexed; and that he, the said Petitioner, hath deposited with the Honorable the Treasurer of the said Colony of New South Wales the sum of Twenty Pounds sterling, for defraying the expense of granting these Letters of Registration, as required by the Act of Council, sixteenth Victoria, number twenty-four; and hath humbly prayed that I would be pleased to grant Letters of Registration, whereby the exclusive enjoyment and advantage of the said invention or improvement might be secured to him for a period of fourteen years: And I, being willing to give encouragement to all inventions and improvements in the arts or manufactures which may be for the public good, and having received a report favourable to the prayer of the said Petition, from competent persons appointed by me to examine and consider the matters stated therein and to report thereon for my information, am pleased, with the advice of the Executive Council, and in exercise of the power and authority given to me by the said Act of Council, to grant, and do by these Letters of Registration grant unto the said Norman Selfe, his executors, administrators, and assigns, the exclusive enjoyment and advantage of the said invention or improvement, for and during the term of fourteen years from the date hereof; to have, hold, and exercise unto the said Norman Selfe, his executors, administrators, and assigns, the exclusive enjoyment and advantage thereof, for and during and unto the full end and term of fourteen years from the date of these presents next and immediately ensuing, and fully to be complete and ended: Provided always, that if the said Norman Selfe shall not, within three days after the granting of these Letters of Registration, register the same in the proper office of the Supreme Court, at Sydney, in the said Colony of New South Wales, then these Letters of Registration, and all advantages whatsoever hereby granted, shall cease and become void.

In witness whereof, I have hereunto set my sign manual, and have caused the present Letters of Registration to be sealed with the seal of the said Colony of New South Wales, at Government House, Sydney, in New South Wales, this third day of July, in the year of our Lord one thousand eight hundred and eighty-three.

[L.S.]

AUGUSTUS LOFTUS.

*Hydraulic Improvements in Closing Shutters and Doors.*

SPECIFICATION of NORMAN SELFE, of No. 141, Pitt-street, in the city of Sydney, and Colony of New South Wales, consulting engineer, for an invention entitled "Improvements in Closing Doors and Shutters."

THIS invention relates to certain improvements in closing doors and shutters by the application of hydraulic power, and has more particular reference to the closing up of warehouses, banks, and other buildings where a large amount of labour would be necessary to effect the work by manual power.

By this invention the door or shutter which is to be closed may be of iron or timber, or a combination, or of any other suitable material or materials, and may close the opening entirely or only in part, and may be of solid material, as an ordinary door and shutter, or of open work, as a grille or lattice.

Such door or shutter is fitted up to slide in grooves (by preference in a vertical direction), and is attached to the ram or piston of a hydraulic cylinder in such a way that the motion of such ram or piston opens and closes it. Water under pressure is supplied to the hydraulic cylinder either from town or city mains, a tank, an accumulator, or other source of supply, and controlled by a valve having suitable openings and pipes for the admission and release of the water. The hydraulic power being proportioned to the work to be done the heaviest doors or shutters can thus be easily and quickly moved.

In order that my invention may be clearly understood, and to enable others to put the same in operation, I now describe the same, in reference to my drawing, where similar letters indicate similar parts.

Figure 1 shows an elevation of a portion of a building, with a door and window, each protected by an open grille.

Figure 2 is a cross-section of same.

Figure 3 is a ground plan.

A is a doorway to building; B is a window opening; C<sup>1</sup> and C<sup>2</sup> are open grilles or gratings made to slide up and down; D<sup>1</sup>, D<sup>2</sup>, D<sup>3</sup>, and D<sup>4</sup>, are guides or grooves, in which C<sup>1</sup> and C<sup>2</sup> slide; E<sup>1</sup> and E<sup>2</sup> are hydraulic rams, supporting grilles C<sup>1</sup> and C<sup>2</sup> respectively; F<sup>1</sup> and F<sup>2</sup> are hydraulic cylinders in which E<sup>1</sup> and E<sup>2</sup> work through stuffing-boxes G<sup>1</sup> and G<sup>2</sup>; H<sup>1</sup> is a water-supply pipe; H<sup>2</sup> a waste pipe; H<sup>3</sup> is a connecting pipe to G<sup>1</sup>; and H<sup>4</sup> a connecting pipe to G<sup>2</sup>; J<sup>1</sup> and J<sup>2</sup> are hydraulic valves to which pipes H<sup>1</sup>,<sup>2</sup>,<sup>3</sup>,<sup>4</sup>, are connected; K is an area or recess in the ground or floor; and L is a covering to K. As shown on the drawing, the grilles are up, the cylinders F<sup>1</sup> and F<sup>2</sup> full of water, and the openings partly closed; by opening the valve J<sup>1</sup> to connect H<sup>3</sup> with H<sup>2</sup> the water will flow out, allowing the ram E<sup>1</sup> and grille C<sup>1</sup> to descend by gravity; when it is desired to close the opening the valve is altered to connect H<sup>3</sup> with H<sup>1</sup>, when the water under pressure will flow into the cylinder, lift the ram, and with it the grille.

In the case of the doors or shutters being required to work horizontally, the hydraulic cylinder would have a piston instead of a ram, and water would be admitted to both sides to open or close as required. It is obvious that there are many different arrangements in detail and combinations which can be made with well-known forms of doors and shutters, and that the hydraulic power can be connected through the intervention of rods, chains, or other appliances; but what I believe to be novel and original and therefore claim as my improvements is the combination of a door or shutter in a building with an hydraulic cylinder, a regulating cock or valve, and a supply of water under pressure, for the purpose of opening and closing it, substantially as set forth.

In witness whereof, I, the said Norman Selfe, have hereto set my hand and seal, this 5th day of May, 1883.

NORMAN SELFE.

This is the specification referred to in the annexed Letters of Registration granted to Norman Selfe, this 3rd day of July, A.D. 1883.

AUGUSTUS LOFTUS.

### REPORT.

Sir,

Sydney, 18 May, 1883.

The application of Mr. Norman Selfe for Letters of Registration for "Hydraulic Improvements in Closing Doors and Shutters" having been referred to us, we have examined the plans and specification accompanying the same, and have now the honor to report that we see no objection to the issue of Letters of Registration as prayed for.

We have, &c.,

JAMES BARNET.

WILLIAM C. BENNETT.

The Under Secretary of Justice.

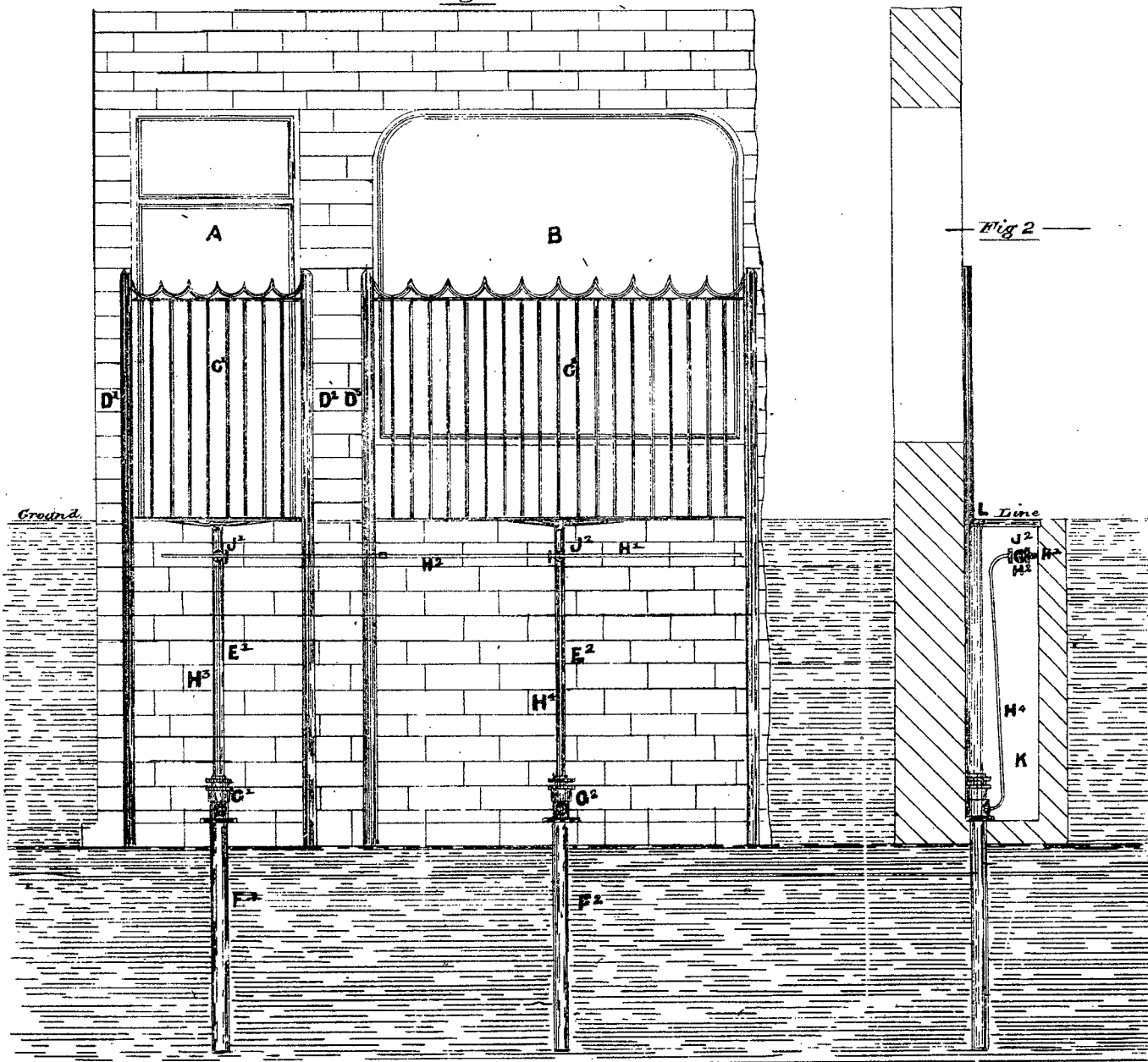
# NORMAN SELFE'S PATENT,

## Hydraulic Improvements in closing Doors and Shutters

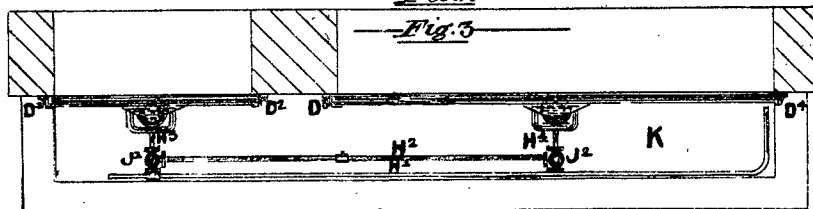
1272

—Elevation—  
—Fig 1—

—Cross section—



—Plan—  
—Fig 3—



*This is the Sheet of Drawings referred to in the annexed  
 Letters of Registration granted to Norman Selfe, this  
 third day of July, A.D. 1883  
 (Sig. 35-) Augustus Loftus.*



A.D. 1883, 3rd July. No. 1273.

IMPROVEMENTS IN TILLING MACHINES.

LETTERS OF REGISTRATION to Charles Edgar Sackett, for Improvements in Tilling Machines.

[Registered on the 4th day of July, 1883, in pursuance of the Act 16 Vic. No. 24.]

BY HIS EXCELLENCY THE RIGHT HONORABLE SIR AUGUSTUS WILLIAM FREDERICK SPENCER LOFTUS (commonly called LORD AUGUSTUS LOFTUS), Knight Grand Cross of the Most Honorable Order of the Bath, a Member of Her Majesty's Most Honorable Privy Council, Governor and Commander-in-Chief of the Colony of New South Wales and its Dependencies.

TO ALL TO WHOM THESE PRESENTS SHALL COME, greeting :

WHEREAS CHARLES EDGAR SACKETT, of Morrinstown, county of Morris, and State of New Jersey, in the United States of America, hath by his Petition humbly represented to me that he is the author or designer of a certain invention or improvement in manufactures, that is to say, of an invention entitled "Improvements in Tilling Machines," which is more particularly described in the specification and the drawing which is hereunto annexed ; and that he, the said Petitioner, hath deposited with the Honorable the Treasurer of the said Colony of New South Wales the sum of Twenty Pounds sterling, for defraying the expense of granting these Letters of Registration, as required by the Act of Council, sixteenth Victoria number twenty-four ; and hath humbly prayed that I would be pleased to grant Letters of Registration, whereby the exclusive enjoyment and advantage of the said invention or improvement might be secured to him for a period of fourteen years : And I, being willing to give encouragement to all inventions and improvements in the arts or manufactures which may be for the public good, and having received a report favourable to the prayer of the said Petition, from competent persons appointed by me to examine and consider the matters stated therein and to report thereon for my information, am pleased, with the advice of the Executive Council, and in exercise of the power and authority given to me by the said Act of Council, to grant, and do by these Letters of Registration grant unto the said Charles Edgar Sackett, his executors, administrators, and assigns, the exclusive enjoyment and advantage of the said invention or improvement for and during the term of fourteen years from the date hereof ; to have, hold, and exercise unto the said Charles Edgar Sackett, his executors, administrators, and assigns, the exclusive enjoyment and advantage thereof for and during and unto the full end and term of fourteen years from the date of these presents next and immediately ensuing, and fully to be complete and ended : Provided always, that if the said Charles Edgar Sackett, shall not, within three days after the granting of these Letters of Registration, register the same in the proper office in the Supreme Court, at Sydney, in the said Colony of New South Wales, then these Letters of Registration, and all advantages whatsoever hereby granted, shall cease and become void.

In witness thereof, I have hereunto set my sign manual, and have caused the present Letters of Registration to be sealed with the seal of the said Colony of New South Wales, at Government House, Sydney, in New South Wales, this third day of July, in the year of our Lord one thousand eight hundred and eighty-three.

[L.S.]

AUGUSTUS LOFTUS.

*Improvements in Tilling Machines.*

SPECIFICATION of CHARLES EDGAR SACKETT, of MORRISTOWN, county of MORRIS, and State of New Jersey, in the United States of America, for an invention entitled "Improvements in Tilling Machines."

THIS invention relates to improved apparatus for tilling the earth. It particularly relates to a method of, and apparatus for, performing simultaneously the several operations involved in the proper cultivation of the soil.

The main object of the invention is to provide an implement which shall adequately perform during one and the said passage, the operations of clearing, inverting, plowing, aerating, pulverizing, distributing, and (if desired) seeding. The invention also aims to perfect the construction of the several component parts of such an implement, and to determine upon the best modes of combining said parts together, so as to secure great strength with lightness of draft, lightness of weight, simplicity of construction, and consequent cheapness.

The principal feature of this invention (which may be carried out in detail in numerous ways) consists in combining with a plough, first:—A mechanism receiving motion from said plough, travelling in a previously made furrow, and provided with devices for pulverizing the earth as it is turned by the ploughshare into said furrow; and secondly, a skim or pioneer plough for clearing the soil before it is operated upon by the main plough.

A convenient form of the complete implement, embodying all the improvements herein set forth, and adapted also to carry the operator, may be briefly described as follows:—

Two ploughs are secured to a practically straight plough-beam which is pivotally suspended from a framework composed of a transverse axle and longitudinal tongue. Lever adjustment devices are provided by which the person operating the implement may easily raise or lower either end of said beam for the purpose of lifting the ploughs from the ground or of regulating the depths of their respective cuts.

The functions of the forward or skim plough are to remove the surface layer of sods, stubble, weeds, or caked earth, to reverse or invert the same, and to deposit the inverted sods, &c., upon the bottom of the previous furrow. The functions of the rear, or main plough, are to take up the cleared soil to any desired depth, as determined by the operation of one of the lever-adjustment devices already mentioned, to pass the raised earth or furrow-slice into a pulverizing device or apparatus, and to assist in retaining the same therein during the process of pulverization.

The plough-beam carries at its forward end a vertically adjustable gauge-wheel and a colter or cutting disc, and the point of the beam is elevated a sufficient distance to produce the necessary draft pressure upon said disc.

The transverse axle hereinbefore alluded to, carries the said pulverizing apparatus, in the form of a hollow wheel upon its furrow end. At the other end is a land-wheel, the spindle of which is secured to the axle by an adjustment device controlled by a registering lever through the agency of which the operator may (without arresting the progress of the implement) raise or lower the land end of the axle, for the purpose of maintaining its horizontality.

The pulverizing wheel is composed of two circular rims, separated by the distance required to make the wheel approximately fit the furrow, and connected together preferably by inwardly curved transverse braces adjustably attached to said rims and forming a grooved periphery or tread. As this wheel advances, it passes over or rides the deposits of the forward plough, cutting the sods and weeds from the furrow edges with its rims, and pressing them down and cutting them with its sharpened transverse braces. Owing to the inward curvature of these braces, the rims sink to the floor of the furrow. The main office of the pulverizing wheel is to comminute and sift the earth which is turned into it by the mould-board of the main plough. For this purpose it is provided with teeth which may project inwardly from the rims or outwardly from the hub. The rotary advance movement of the wheel keeps the loose hearth in a constant state of agitation within it, until its component masses are sufficiently reduced in size to pass through the spaces intervening between the bars.

The furrow space directly behind the pulverizing wheel is thus continuously supplied with finely divided earth, which is dropped loosely into it from the wheel, in a light, porous and aerated condition. As the most finely divided portion of the soil is the first to fall through the spaces in the wheel, such soil will form the lower stratum of the prepared seed-bed. It is well known that if a soil is finely pulverized and well aerated to a considerable depth, the roots of growing plants will penetrate far deeper than if it is pulverized upon the top only, and will find protection and moisture in hot and dry seasons, thus ensuring an uninterrupted and normal growth of the crops.

In conjunction with the mechanism thus described, there is provided a seeding device, capable of being removed when not required, and so constructed as to introduce the seed into the midst of the falling earth.

Thus all the operations involved in the complete preparation and seeding of the soil may be simultaneously effected.

During the progress of the machine, the draft animals are never obliged to step upon the prepared earth.

The improved process has been found applicable in earth when much too moist for ploughing by the ordinary means.

In the accompanying drawings, fig. 1 shows a common plough of well-known construction combined with a simple form of pulverizer and a skim plough; fig. 2 is a perspective view of the perfected tilling machine (without the seeding device) in operation; fig. 3 is a plan diagram showing the relative positions of the two ploughs, and the widths of their respective cuts; fig. 4 is a side view of the seeding device detached; fig. 5 shows a series or gang of main ploughs in simultaneous action, each provided with an independent pulverizer; fig. 6 illustrates a convenient mode of organization of the several parts of a complete implement. Similar reference letters are applied to corresponding parts throughout the figures.

Referring to fig. 1, A<sup>1</sup> is an ordinary plough, and B its beam. To this beam is attached a rod or bar B<sup>2</sup>, bent so as to extend into the furrow made by the plough on its previous trip. The bar is terminated by a series of vertical teeth Y, which pulverize the earth as it is turned over by the ploughshare.

The

*Improvements in Tilling Machines.*

The fig. shows three teeth projecting downward, but it is evident that the number, the mode of arrangement, and the exact character of said teeth is immaterial so long as they perform the office of pulverizers.

There is also attached to the beam B a forward or skim plough A<sup>2</sup>, the office of which is to clear the soil by removing the top layer of sods, weeds, dry earth, &c., which layer is inverted and delivered by it into the adjoining furrow, to be afterwards covered up with the pulverized earth. This relieves the pulverizer from the accumulation of material which would clog the teeth, and impede the progress of the implement, and it also insures the complete burial of the top soil and its vegetable growth, the advantages of which are well-known.

In fig. 2, the complete tiller is shown in operation. The main plough A<sup>1</sup> and skim plough A<sup>2</sup> are connected to the beam B by means of suitable braces or standards C<sup>1</sup>, C<sup>2</sup>, and clamps D<sup>1</sup>, D<sup>2</sup>. The beam B is slightly inclined to the horizontal plane, the point of the beam being elevated above its rear, and sufficiently to insure the requisite draft-pressure upon the gauge wheel E<sup>1</sup>, and colter E<sup>2</sup>, which last are carried by mechanism F, susceptible of vertical adjustment. Advantage being taken of the clearing action of the forward plough of the beam B, is made practically straight, and there is given to it the inclination described, so that the beam is low at its junction with the rear plough standard. The use of a beam provided with a curved throat is thus avoided. In the ordinary plough much of the strain falls on the curved throat, which must accordingly be made very heavy, but with a straight beam disposed in the manner described, the strain is exerted directly in the line of its length, and accordingly its cross section may be materially decreased. This, together with its diminished length, greatly reduces its weight.

The framework of the implement is composed of a straight transverse axle G, and a tongue H, extending parallel to the line of motion, and connected to said axle at a point near its centre.

The plough beam is pivotally suspended from this framework, and mechanisms are provided for preventing lateral movement of the beam, and for vertically adjusting either end thereof. Thus the rear end of the beam enters a guide loop J, depending from the axle G, within which loop it has free vertical motion. The same end of the beam may be brought to any required vertical position by means of the angle lever K, which is placed in a convenient location to be manipulated by the right hand of the operator, when seated upon the spring seat L. In order to maintain the beam in such position, a registering device is provided, consisting of the notched segment frame M<sup>1</sup>, the stop M<sup>2</sup>, and its withdrawing handle M<sup>3</sup>. All lateral movements of the forward end of the beam are prevented by yoke braces, N<sup>1</sup>, N<sup>2</sup>, rigidly connected to the beam at O<sup>1</sup> and O<sup>2</sup>, and articulating with the axle in the pivotal bearings P<sup>1</sup>, P<sup>2</sup>, connected upon the axle G. The forward end of the beam is hung from the angle lever R, pivoted at R<sup>1</sup> to the tongue H, which lever is also capable of adjusting by the right hand of the operator. By means of these levers the operator may vary the depth of cut by either plough, or may lift both ploughs above the ground when he desires to turn or transport the implement.

The land wheel S revolves upon its spindle S<sup>1</sup>, which is carried by the angle-lever S<sup>2</sup>. The latter is pivoted at S<sup>3</sup> to an elbow S<sup>4</sup>, upon the land end of the axle G. A segment S<sup>5</sup> and registering lever S<sup>6</sup>, are also provided for securing the system when proper adjustment is reached. The lower S<sup>2</sup> is manipulated by the operator with his left hand. It enables him to keep the axle G and seat L in a horizontal, and the ploughs in an upright position.

In order that the forward plough may invert its furrow-slice, or the top layer of sods, &c., which it removes from the surface, its ploughshare is made somewhat narrower than that of the rear plough, so as to leave a narrow uncut strip upon the furrow edge which acts as a hinge for said furrow-slice. There is also given to the mould-board of said forward plough the curved form and structure requisite to effect a semi-revolution of said furrow-slice upon said hinge, as it is delivered into the adjoining previously-made furrow. This operation will be understood by reference to fig. 3, in which the ploughs A<sup>1</sup> and A<sup>2</sup> are shown in horizontal projection, and the boundaries of their respective cuts are indicated by dotted lines.

The pulverizing wheel T revolves upon the furrow end of the axle G. It travels as hereinbefore explained in the last of the series of furrows previously opened. It is made of such breadth as to easily fit the furrow, the distance between the rims T<sup>1</sup> and T<sup>2</sup> being regulated accordingly. These rims are connected together by transverse braces U<sup>1</sup>, U<sup>2</sup>, U<sup>3</sup>, &c. The rims are provided with holes at convenient distances apart through which the removable braces are bolted. The operator can thus adjust the width of furrow opening to the condition of the land, or to the strength of the team employed, by inserting the removable bars in any of the bolt-holes at pleasure. The braces are preferably curved inwardly as shown, so as to form a grooved periphery or tread, and the outer faces of the transverse braces as well as the rims, if desired, are formed with sharp cutting edges. As the wheel advances, the rim T<sup>1</sup> seaves to cut the sods, weeds, &c., from the land edge of the furrow in which it moves. The braces serve to press the same down to the bottom of the furrow, and there to cut them transversely. Owing to the curvature of the braces, the rims of the wheel may be forced by the weight of the implement to the floor of the furrow, and the wheel is thus made to ride the deposits of the forward plough without being materially elevated.

The wheel is constructed upon an elongated hub V, provided with inner and outer boxes or collars, V<sup>1</sup>, V<sup>2</sup>. From each of these boxes a series of spokes, W<sup>1</sup>, W<sup>2</sup>, radiates. The spokes are of steel or iron, and are made as light as is consistent with requisite strength. Pointed or wedge-shaped teeth, W<sup>3</sup>, W<sup>4</sup>, &c., are provided for the purpose of breaking up and pulverizing the earth. The teeth are independently removable, and provision is made for their attachment at numerous points upon the rims. The proper number, length, and position of said teeth, and the shape and construction of the transverse bars to secure the best result in any particular case, will depend upon the character of the soil worked by the implement.

The mould-board of the main plough is expanded into or attached to a screen Y<sup>1</sup>, acting to retain the earth within the wheel, until sufficiently pulverized to fall through the peripheral spaces.

The implement, as above described, tends to move in a direct line, or a line determined by the previous furrow in which the pulverizing wheel revolves. The tongue H<sup>1</sup> and yoke-braces J maintain the direct forward action of the beam. The usual land sides of either or both ploughs may be therefore dispensed with, and their resulting weights and friction avoided.

If

*Improvements in Tilling Machines.*

If desired, the operation of seeding may be carried on conjointly with the several operations performed by the implement as hereinbefore shown. For this purpose a seed-drill Z (fig. 4) is provided of the most approved known construction for sowing both fertilizers and seed together. In place of the ordinary discharge openings, however, small dropping tubs, Z<sup>1</sup>, Z<sup>2</sup>, are used. These are placed directly behind the pulverizing wheel. For the purpose of supporting the drill in the rear of the pulverizing wheel, a bent bracket framework, Z<sup>3</sup>, is provided, which may be fastened to the axle G at points Z<sup>4</sup>, Z<sup>5</sup>, and Z<sup>6</sup>. The feeding may be effected by the usual chain Z<sup>7</sup> and chain wheels Z<sup>8</sup> and Z<sup>9</sup>. The seed are dropped in the midst of the falling earth, and therefore no special covering-devices are necessary, though such devices may be employed if desired. The action of the drill is checked at the will of the operator by a small lever Z<sup>10</sup>, which throws the chain wheel Z<sup>9</sup> out of gear.

In fig. 5, a method is shown of ganging the system described above. A rectangular framework, 1, 2, 3, 4, is divided into longitudinal divisions by braces 5. In each division, a system of ploughs, such as described, is suspended. The pulverizing wheel of each main plough is located in an adjoining division. The framework is supported at its forward end upon one or more adjustable gauge-wheels E<sup>2</sup>. The divisions are crossed at suitable points by axles 6, 7, to which the ploughs are adjustably attached, or upon which the pulverizing wheels revolve.

A land wheel is carried at the land end of the complete framework, and one of the pulverizing wheels at the furrow side. In this manner, two, three, or even more systems of ploughs may be operated in gangs, and steam used as the motive power, the broad treads of the pulverizing wheels making the implement run uniformly and smoothly.

The above description of the complete tilling mechanism illustrated in fig. 2, besides explaining the nature of the several processes performed by the complete implement, and the detailed construction of each of the several elements of apparatus by which said processes are carried out, sets forth an advantageous mode of combining said elements together in order to execute all of said processes simultaneously.

There are other modes in which the same elements, performing the same offices, may be combined, and yet constitute an implement embodying, both in its construction and mode of operation, the principles of this invention. Thus there are two positions in which the skim-plough may be placed, in either of which it will perform its proper functions equally well. It is not essential that the skim-plough should be directly in line with the main plough, providing that it occupies such a position that it is the first to enter and operate upon the untilled soil. The several functions of the skim-plough are to remove the top layer of sods, weeds, &c., to invert the same, and to deposit it upon the bottom of the deepened furrow previously made by the main plough, there to be subsequently traversed by the pulverizing wheel.

The operations may be performed with excellent practical results by means of the organization or arrangement shown in fig. 6, in which the skim-plough is transferred to a position at the side and slightly in the rear of the main plough, so as to move in an advance furrow. The construction of the framework of the mechanism is necessarily somewhat modified in accordance with these changes, the alterations, however, being merely of a formal or constructive character, such as would suggest themselves to one skilled in the art.

By this organization, the plough A<sup>2</sup>, after inverting its furrow-slice, delivers it immediately in the rear of plough A<sup>1</sup>. During the first trip upon an untilled field, the plough A<sup>2</sup> alone should be lowered into position to strip the sod. In the second round, the plough A<sup>1</sup> is lowered into the furrow previously stripped by the plough A<sup>2</sup>. In the third round, the pulverizing wheel would take the deepened furrow, traversing the inverted sods, and pulverizing the earth in the manner hereinbefore described.

In either of the two positions thus suggested for the pioneer or skim-plough, said pioneer-plough will be the first to operate upon the untilled soil. In either case, it will deliver its inverted furrow-slice into a parallel adjacent furrow previously deepened by the passage of the main plough. In either case also, said inverted layer of soil is subsequently traversed by the pulverizing wheel, which presses it down, cuts it, and buries it beneath a shower of pulverized earth.

The character of the tillage performed in each case is therefore identical, and the two modes of combination of the different parts may be considered as practical equivalents of each other so far as the process and result are concerned. The preferable mode to be employed in the construction of a particular implement will depend upon the nature of the soil, the form of draft power to be employed, and other conditions. The principal advantage arising from the mode illustrated in fig. 6 arises from the symmetrical distribution of the draft resistance. The main plough is centrally placed between the pulverizing wheel and the pioneer-plough. The mean line of draft resistance therefore falls at about the centre of the implement.

Having thus described the invention, what I claim as new, and desire to secure by Letters Patent is:—

- First—A mechanism attached to a plough, travelling in a previously made furrow, as said plough is advanced, and provided with teeth or equivalent devices for pulverizing the earth.
- Second—The combination, substantially as hereinbefore set forth, of the straight plough-beam, with the forward skim-plough and rear main plough carried thereby.
- Third—The plough-beam carrying the skim and main ploughs, and the axle of the implement in combination, substantially as hereinbefore set forth, with mechanism consisting of the guide-loop and guide-rods, for preventing all except vertical movements of said beam.
- Fourth—The plough-beam carrying the skin and main ploughs, and rectangular framework composed of the transverse axle and longitudinal tongue, in combination substantially as hereinbefore set forth, with devices for suspending said beam from said framework, and levers for vertically adjusting either end of said beam.

Fifth

*Improvements in Tilling Machines.*

- Fifth—The combination, substantially as hereinbefore set forth, of the plough-beam carrying the ploughs, the axle of the implement, the mechanism for preventing lateral movement of the beam, and mechanism for vertically adjusting either of its ends.
- Sixth—The combination, substantially as hereinbefore set forth, of a transverse axle of a plough carriage, a pulverizing wheel carried on one end thereof, and a land-wheel adjustably carried on the other.
- Seventh—The combination, substantially as hereinbefore set forth, of the axle, a segment casting carried at the land end thereof, an angle-lever articulating and registering with said segment, a spindle carried by said angle-lever, and the land wheel revolving upon said spindle.
- Eighth—The combination, substantially as hereinbefore set forth, of a main plough provided with a ploughshare determining the width of furrow, and a front plough provided with a ploughshare narrower than the furrow for the purpose of leaving an uncut or hinge edge on the furrow side.
- Ninth—The combination, substantially as hereinbefore set forth, of a main ploughshare determining the width of furrow, a forward ploughshare made narrower than the furrow for the purpose of leaving an uncut edge upon the furrow-slice, and a mould-board shaped to invert the furrow-slice by turning it upon said uncut edge.
- Tenth—A revolving soil pulverizer, rolling in a previously made furrow, adapted to receive the earth from the land side, provided with internal devices for pulverizing the earth, and circumferential spaces through which the pulverized earth may fall into said furrow.
- Eleventh—The combination, substantially as hereinbefore set forth, of a plough, and in rigid connection therewith a pulverizing wheel, rolling in the furrow last made, and adapted to receive and pulverize the earth from the furrows in process of making.
- Twelfth—The combination, substantially as hereinbefore set forth, of a forward skim-plough turning its furrow-slice into the furrow last made, a pulverizing wheel riding the deposits of the skim-plough, and a main plough, turning its furrow-slice into said pulverizing wheel.
- Thirteenth—The combination, substantially as hereinbefore set forth, of the forward plough turning its furrow-slice into the previously made furrow, and a skeleton pulverizing wheel having a grooved or recessed tread, in order that it may pass over the deposits of said forward plough without being materially elevated.
- Fourteenth—In a skeleton pulverizing wheel, the combination, substantially as hereinbefore set forth, of the long hub, the end boxes thereof, a series of spokes radiating from each box, the circular rims, and the transverse braces.
- Fifteenth—The combination, substantially as hereinbefore set forth, of the skeleton framework of the pulverizing wheel, and the inwardly projecting teeth adjustable upon said framework.
- Sixteenth—In a vertical wheel pulverizer, the combination, substantially as hereinbefore set forth, of transverse removable bars and perforated rims, whereby the area of the discharge opening may be adjusted.
- Seventeenth—The combination, substantially as hereinbefore set forth, of a main plough and pulverizing wheel, with a screen or extension of the mould-board and said main plough, for the purpose of confining the earth within said wheel during the process of pulverization.
- Eighteenth—In combination with a tilling apparatus, consisting of a plough and pulverizer acting conjointly, a seeding device adapted to operate substantially as hereinbefore set forth.
- Nineteenth—In combination with a tilling apparatus, consisting of a plough acting conjointly with a pulverizing wheel, from which the earth falls loosely, of a seeding device provided with tubes for delivering seed into the falling earth, substantially as hereinbefore set forth.
- Twentieth—In a tilling apparatus, the combination in gangs of a series of ploughs in adjacent furrows, and a series of pulverizers, each working conjointly with one of said series of ploughs, substantially as hereinbefore set forth.
- In witness whereof, I, the said Charles Edgar Sackett, have hereto set my hand and seal, this thirty-first day of January, one thousand eight hundred and eighty-three.

CHARLES EDGAR SACKETT.

Witnesses—

DANIEL W. EDGECOMB.  
HOWARD R. BUTTLER.

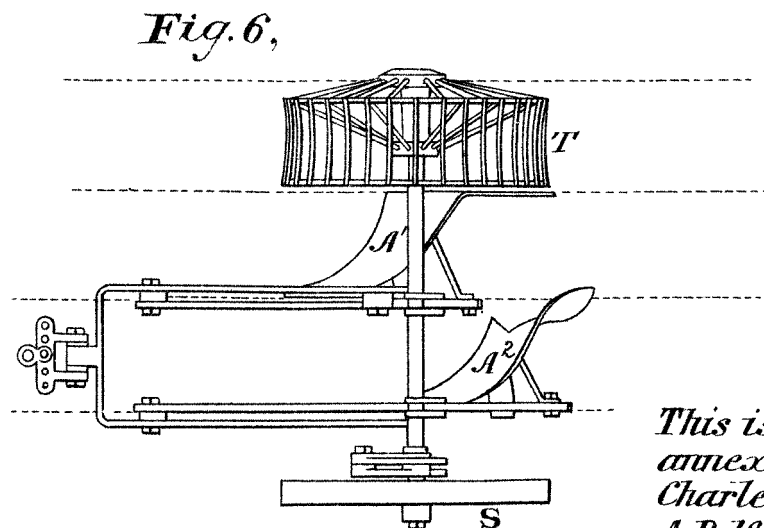
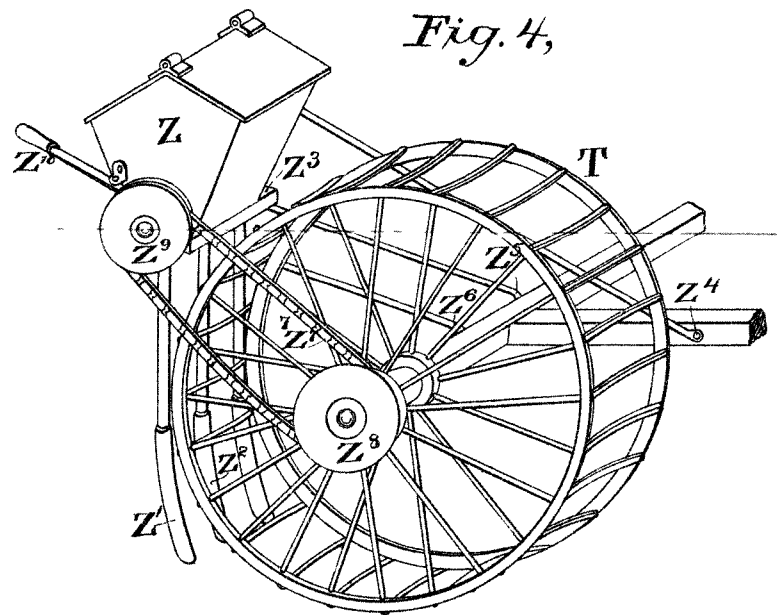
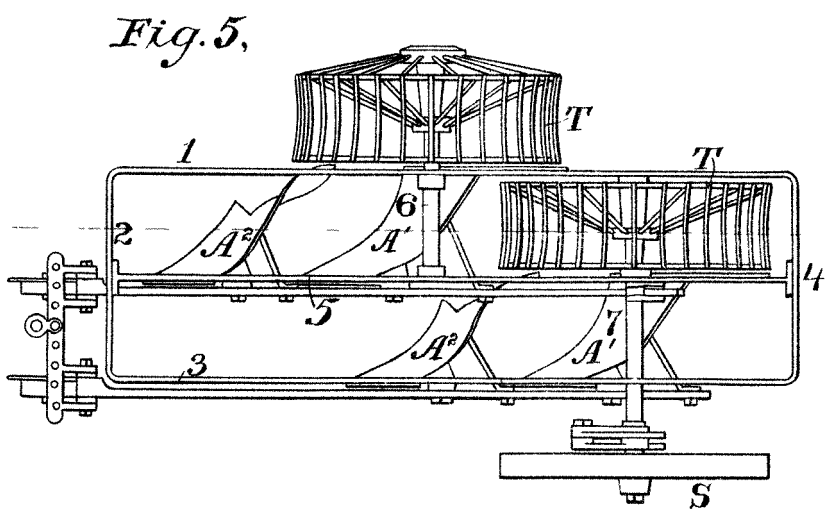
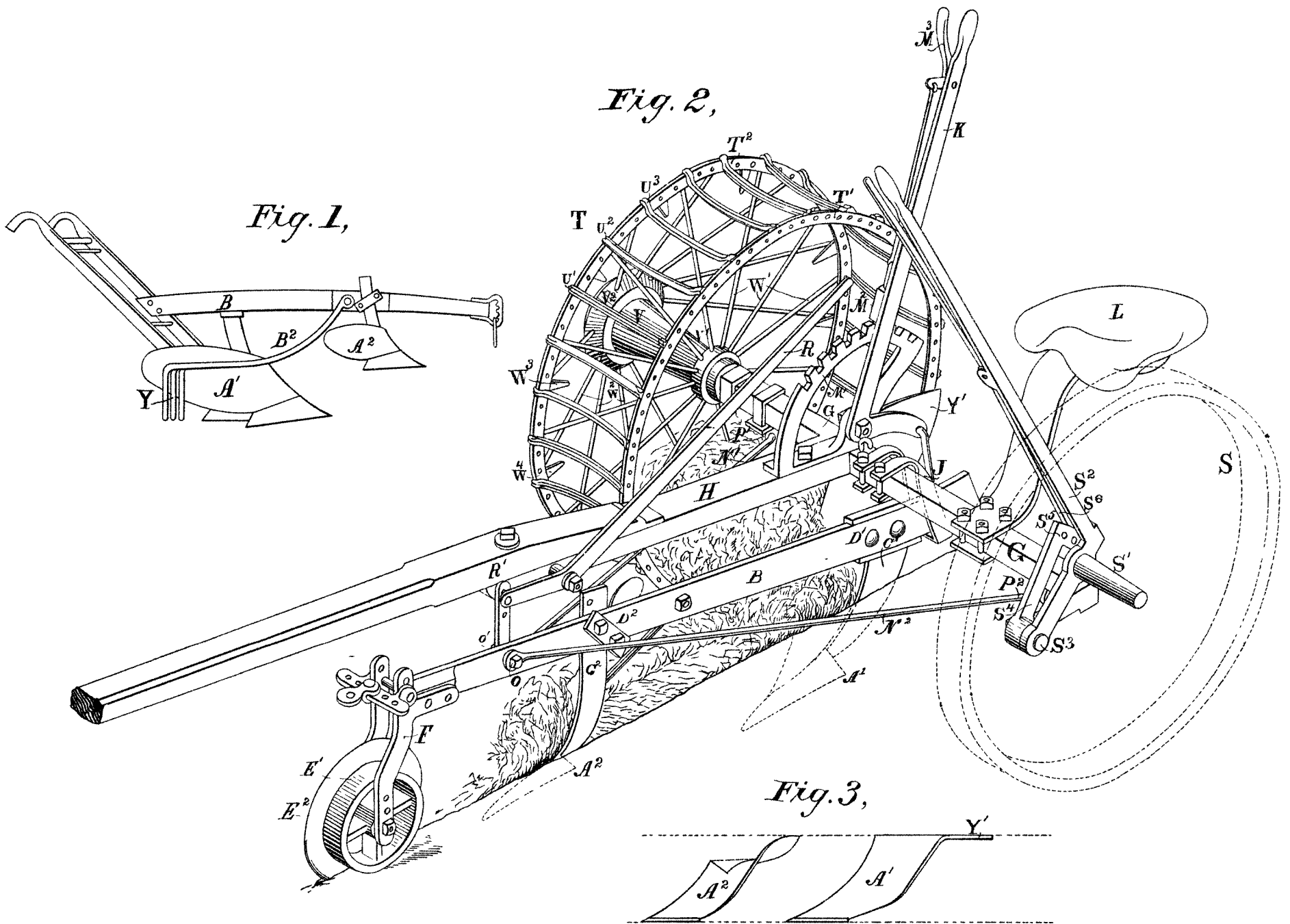
This is the specification referred to in the annexed Letters of Registration granted to Charles Edgar Sackett, this third day of July, A.D. 1883.

AUGUSTUS LOFTUS.

REPORT







*This is the Sheet of Drawings referred to in the annexed Letters of Registration granted to Charles Edgar Sackett, this third day of July A.D. 1883.*

*Augustus Loftus.*



---

A.D. 1883, 14th July. No. 1275.

---

**IMPROVEMENTS IN SAFETY GUARDS FOR TRAM AND RAILWAY ROLLING STOCK.**

---

**LETTERS OF REGISTRATION to Pehr Adolph Holmgren, for Improvements in Safety Guards for Tram and Railway Rolling Stock.**

[Registered on the 17th day of July, 1883, in pursuance of the Act 16 Vic. No. 24.]

---

BY HIS EXCELLENCY THE RIGHT HONORABLE SIR AUGUSTUS WILLIAM FREDERICK SPENCER LOFTUS (commonly called LORD AUGUSTUS LOFTUS), Knight Grand Cross of the Most Honorable Order of the Bath, a Member of Her Majesty's Most Honorable Privy Council, Governor and Commander-in-Chief of the Colony of New South Wales and its Dependencies.

TO ALL TO WHOM THESE PRESENTS SHALL COME, greeting :

WHEREAS PEHR ADOLPH HOLMGREN, of 257, Kent-street, Sydney, in the Colony of New South Wales, watch and clock maker, hath by his Petition humbly represented to me that he is the author or designer of a certain invention or improvement in manufactures, that is to say, of an invention entitled "Improvements in Safety Guards for Tram and Railway Rolling Stock," which is more particularly described in the specification and the sheet of drawings which are hereunto annexed ; and that he the said Petitioner hath deposited with the Honorable the Treasurer of the said Colony of New South Wales the sum of Twenty Pounds sterling, for defraying the expense of granting these Letters of Registration, as required by the Act of Council, sixteenth Victoria, number twenty-four ; and hath humbly prayed that I would be pleased to grant Letters of Registration, whereby the exclusive enjoyment and advantage of the said invention or improvement might be secured to him for a period fourteen years : And I, being willing to give encouragement to all inventions and improvements in the arts or manufactures which may be for the public good, and having received a report favourable to the prayer of the said Petition, from competent persons appointed by me to examine and consider the matters stated therein and to report thereon for my information, am pleased, with the advice of the Executive Council, and in exercise of the power and authority given to me by the said Act of Council, to grant, and do by these Letters of Registration grant unto the said Pehr Adolph Holmgren, his executors, administrators, and assigns, the exclusive enjoyment and advantage of the said invention or improvement, for and during the term of fourteen years from the date hereof ; to have, hold, and exercise unto the said Pehr Adolph Holmgren, his executors, administrators, and assigns, the exclusive enjoyment and advantage thereof, for and during and unto the full end and term of fourteen years from the date of these presents next and immediately ensuing, and fully to be complete and ended : Provided always, that if the said Pehr Adolph Holmgren, shall not within three days after the granting of these Letters of Registration register the same in the proper office in the Supreme Court, at Sydney, in the said Colony of New South Wales, then these Letters of Registration, and all advantages whatsoever hereby granted, shall cease and become void.

In witness whereof, I have hereunto set my sign manual, and have caused the present Letters of Registration to be sealed with the seal of the said Colony of New South Wales, at Government House, Sydney, in New South Wales, this fourteenth day of July, in the year of our Lord one thousand eight hundred and eighty-three.

[L.s.]

AUGUSTUS LOFTUS.

*Improvements in Safety Guards for Tram and Railway Rolling Stock.*

SPECIFICATION of PEHR ADOLPH HOLMGREN, of No. 257, Kent-street, Sydney, in the Colony of New South Wales, watch and clock maker, for an invention entitled, "Improvements in Safety Guards for Tram and Railway Rolling Stock."

MY invention has been designed to provide means whereby collisions between tram or railway rolling stock and vehicles or foot passengers shall not cause so much damage as heretofore, or be attended with the loss of life.

My improvements consist, first, in boxing the locomotive within a practically smooth case commencing close to the surface of the ground, the forward end of which is provided with a spring extension. On this extension, which I prefer to hinge at its centre, are carried cushions, but these are not essential to the success of the invention. The second part consists in providing the cars or carriages with what may be called an "apron" below the continuous footstep, which apron extends upwards at either end and curves inwards, thus presenting to the line of travel a rounded smooth surface, which also may be provided with cushions.

But in order that my invention may be clearly understood, I will now make reference to the drawings wherein my improvements are shown as applied to a tram-motor and to a tram-car; but of these I have shown no more parts than are necessary to illustrate the invention.

Figure 1 is a side elevation partly in section; figure 2, a plan; figure 3, a cross section; and figure 4, end elevation, with some parts removed, of a tram-motor fitted with one class of my safety-guards. A is the ordinary platform frame, which I extend as shown at the forward end. B is the practically smooth case strengthened by angle-irons B<sup>1</sup>; B<sup>2</sup> is a hinged door therein for access to the axle-boxes, and it is flush with the outer case. B<sup>3</sup> is an opening in the casing above the platform for the fireman and engineer; this also may have a flush door. C is an upright or stem; C<sup>1</sup> stays thereto from front of boiler. C<sup>2</sup> are spindles carrying spiral springs; these spindles C<sup>2</sup> terminate upright, having eyes C<sup>3</sup>, through which passes bolt C<sup>4</sup>. D are curved plates hinged to bolt C<sup>4</sup>, and D<sup>1</sup> is a cushion. D<sup>2</sup> is a flat spring.

It will be seen that when moving along, should the cushions on plates D strike any unstable object, such as a cab or a man, it or he will be pushed out of the way, and the force of the blow will not be severe as there are first the cushion D<sup>1</sup>, secondly the hinge on bolt C<sup>4</sup>, and lastly the springs on spindle C<sup>2</sup> and springs D<sup>2</sup> to ease it off. Should it be necessary that the engine should run alternate ends forward, I make both with extensions, and provide openings for the coupling-irons and chains. I might also run a roof-framing from the top of my box frame, and cover it in, providing windows and other openings where needed.

Figures 5 and 6 show respectively section and plan of a different spring extension, E being a frame on which slides casing F with or without cushions F<sup>1</sup>. E<sup>1</sup> are wheels which normally ride just above the rails. F<sup>2</sup> are spindles, on which are spiral springs.

This extension is more suitable for those places where there is not much vehicular traffic, and a person struck by it would have a tendency to sit down upon the casing F, and the force would in this case be taken by the cushion F<sup>1</sup>, and by the springs on spindles F<sup>2</sup>.

Figures 7, 8, and 9 are respectively plan, end view, and partial side view of the car-guard. G is the plate or apron fixed to continuous step H. This apron extends upwards and curves inwards, as shown at G<sup>1</sup>. G<sup>2</sup> is a cushion which projects beyond the step.

The guard which this presents is easily seen in the plan, figure 7; and a person could not easily get within the apron, as I intend at a coupling of cars that these should meet or nearly meet. There is plenty of room for coupling-irons and chains in the centre.

The cushions I have mentioned I would prefer to be air-cushions; but they may be of any ordinary make.

Having thus particularly described and explained my said invention, I would have it understood that I do not confine myself to the exact curves, shapes, or sizes of any parts, nor to the materials of which they may be constructed, so long as the nature of my invention be retained; but what I claim as my improvements in safety guards for tram and railway rolling stock are—

First—Boxing the locomotives within a practically smooth case, whose bottom edge is close to the ground, and which is provided with a spring extension at one or both ends, substantially as herein described and explained.

Second—The combination and arrangement of parts illustrated in figures 1 to 4 of the drawings, constituting a locomotive safety guard, substantially as herein described and explained.

Third—The combination and arrangement of parts illustrated in figures 5 and 6, substantially as described.

Fourth—Providing a tram-car or railway-carriage with an apron extending under and along the continuous footstep, and at the ends reaching upwards, and presenting a rounded edge or cushion to the street traffic, substantially as herein described and explained, as illustrated in figures 7, 8, and 9 of the drawings.

In witness whereof, I, the said Pehr Adolph Holmgren, have hereto set my hand and seal, this fifth day of May, one thousand eight hundred and eighty-three.

Witness—

FRED WALSH,

Manager, Edward Waters' Patent Office, Sydney.

P. A. HOLMGREN.

This is the specification referred to in the annexed Letters of Registration granted to Pehr Adolph Holmgren, this fourteenth day of July, A.D. 1883.

AUGUSTUS LOFTUS.

---

*Improvements in Safety Guards for Tram and Railway Rolling Stock.*

---

**REPORT.**

Sir,

Sydney, 18 May, 1883.

In reference to your B.C. of 11th instant, submitting a Petition for Letters of Registration for an invention entitled "Improvements in Safety Guards for Tram and Railway Rolling Stock," from Mr. Pehr Adolph Holmgren, of Sydney, we have the honor to inform you that, having examined the drawings and specification accompanying the Petition, we recommend that Letters of Registration be granted for the invention in question, as shown in the drawings and described in the specification before referred to.

We have, &c.,

JOHN WHITTON.  
E. O. MORIARTY.

The Under Secretary of Justice.

---

(Drawings—one sheet.)

---

**No. 1276.**

[Assignment of No. 1170. See Letters of Registration, for 1882, p 459 ]

---

**No. 1277.**

[Copy Assignment of Patent Rights.]

---

# P. A. HOLMCREN'S PATENT.

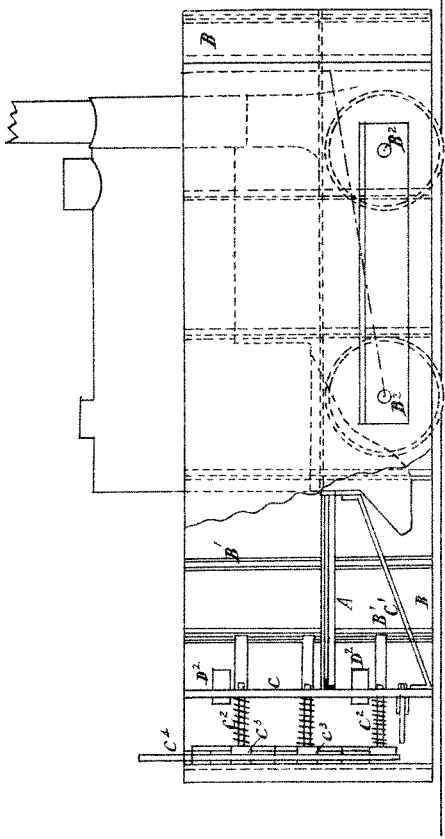


Fig. 1.

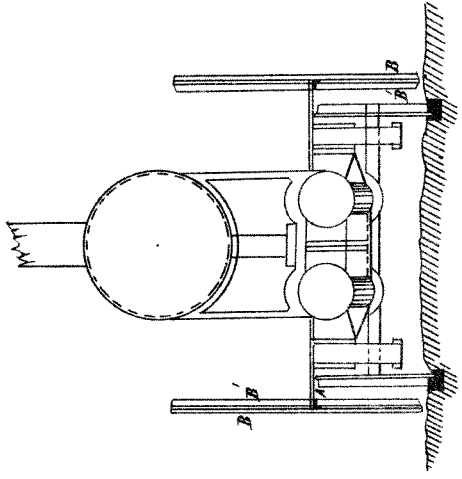


Fig. 3.

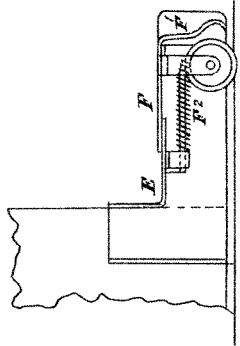


Fig. 5.

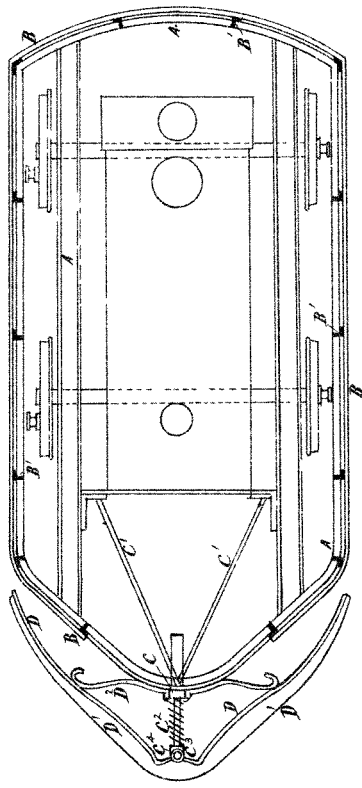


Fig. 2.

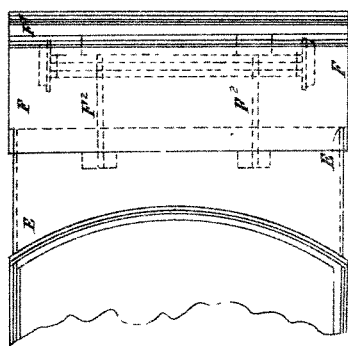


Fig. 6.

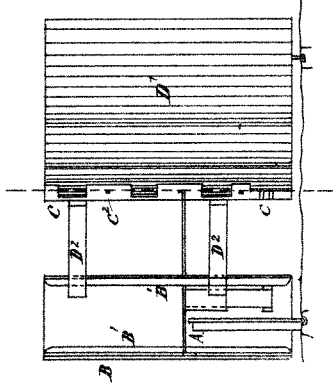


Fig. 4.

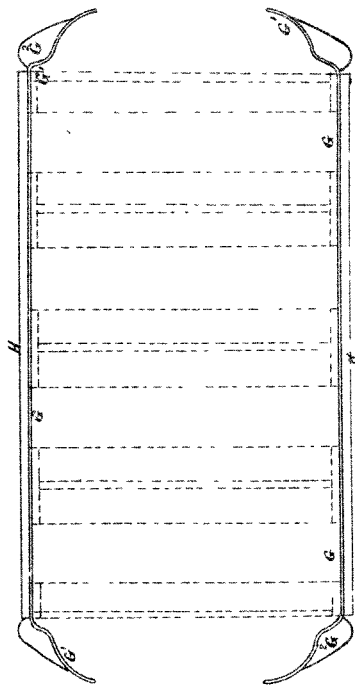


Fig. 7.

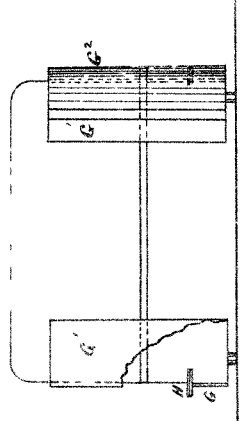


Fig. 8.

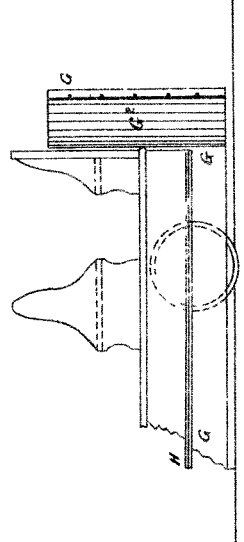


Fig. 9.

This is the Sheet of Drawings referred to in the covered Letters or Registration granted to Peter Adolph Holmgren this fourteenth day of July A. D. 1885  
Augustus Loftis.



A.D. 1883, 26th July. No. 1278.

BITUMINOUS CONCRETE.

LETTERS OF REGISTRATION to Walter Andrew Harper, John Campbell Dibbs, and Henry Gilbert Carson Woods, for an invention entitled "Bituminous Concrete."

[Registered on the 26th day of July, 1883, in pursuance of the Act 16 Vic. No. 24.]

BY HIS EXCELLENCY THE RIGHT HONORABLE SIR AUGUSTUS WILLIAM FREDERICK SPENCER LOFTUS (commonly called LORD AUGUSTUS LOFTUS), Knight Grand Cross of the Most Honorable Order of the Bath, a Member of Her Majesty's Most Honorable Privy Council, Governor and Commander-in-Chief of the Colony of New South Wales and its Dependencies.

TO ALL TO WHOM THESE PRESENTS SHALL COME, greeting :

WHEREAS WALTER ANDREW HARPER, JOHN CAMPBELL DIBBS, and HENRY GILBERT CARSON WOODS, all of George-street, Sydney, in the Colony of New South Wales, have by their Petition humbly represented to me that they are the authors or designers of a certain invention or improvement in manufactures, that is to say, of an invention entitled "Bituminous Concrete," which is more particularly described in the amended specification which is hereunto annexed; and that they, the said Petitioners, have deposited with the Honorable the Treasurer of the said Colony of New South Wales the sum of Twenty Pounds sterling, for defraying the expense of granting these Letters of Registration, as required by the Act of Council, sixteenth Victoria, number twenty-four; and have humbly prayed that I would be pleased to grant Letters of Registration, whereby the exclusive enjoyment and advantage of the said invention or improvement might be secured to them for a period of fourteen years: And I, being willing to give encouragement to all inventions and improvements in the arts or manufactures which may be for the public good, and having received a report favourable to the prayer of the said Petition, from competent persons appointed by me to examine and consider the matters stated therein and to report thereon for my information, am pleased, with the advice of the Executive Council, and in exercise of the power and authority given to me by the said Act of Council, to grant, and do by these Letters of Registration grant unto the said Walter Andrew Harper, John Campbell Dibbs, and Henry Gilbert Carson Woods, their executors, administrators, and assigns, the exclusive enjoyment and advantage of the said invention or improvement, for and during the term of fourteen years from the date hereof; to have, hold, and exercise unto the said Walter Andrew Harper, John Campbell Dibbs, and Henry Gilbert Carson Woods, their executors, administrators, and assigns, the exclusive enjoyment and advantage thereof, for and during and unto the full end and term of fourteen years from the date of these presents next and immediately ensuing, and fully to be complete and ended: Provided always, that if the said Walter Andrew Harper, John Campbell Dibbs, and Henry Gilbert Carson Woods shall not, within three days after the granting of these Letters of Registration, register the same in the proper office in the Supreme Court, at Sydney, in the said Colony of New South Wales, then these Letters of Registration, and all advantages whatsoever hereby granted, shall cease and become void.

In witness whereof, I have hereunto set my sign manual, and have caused the present Letters of Registration to be sealed with the seal of the said Colony of New South Wales, at Government House, Sydney, in New South Wales, this twenty-sixth day of July, in the year of our Lord one thousand eight hundred and eighty-three.

[L.S.]

AUGUSTUS LOFTUS.

*Bituminous Concrete.*

SPECIFICATION of WALTER ANDREW HARPER, JOHN CAMPBELL DIBBS, and HENRY GILBERT CARSON WOODS, all of George-street, Sydney, in the Colony of New South Wales, for an invention entitled "Bituminous Concrete."

THE invention consists in the manufacture and use of a new material suitable for paving, road-making, pipes, and various forms of manufacture, and which can be more easily and economically adopted for ordinary uses than those at present employed.

The name of the material is Bituminous Concrete, and is manufactured as is hereinafter described.

A quantity of English bitumen or any other available hydro-carbon is heated to a considerable temperature, until it assumes the consistency of medium pitch. After the volatile oils are expelled, a quantity of carbonate of lime and aluminium silicate or clay is added, and the whole mixed perfectly until it assumes a granulated form.

In this stage it can be cast into moulds or allowed to cool, and is used as desired, and may be laid down after being reheated.

The manufacture and combination form the following, which we claim as special novelties:—

First—The combination of reduced bituminous substances with aluminium silicate clay or shale substantially as described.

Second—The combination of reduced bituminous substances with aluminium silicate clay or shale, with a proportion not exceeding ten (10) per centum of carbonate of lime, substantially as described.

Third—The combinations forming the Bituminous Concrete, substantially as described.

Fourth—The combination of asbestos slag-wool or similar substances with Bituminous Concrete, substantially as described.

Dated at Sydney this eighth day of June, in the year of our Lord one thousand eight hundred and eighty-three.

WALTER A. HARPER.  
JOHN C. DIBBS.  
CARSON WOODS.

This is the amended specification referred to in the annexed Letters of Registration granted to Walter Andrew Harper, John Campbell Dibbs, and Henry Gilbert Carson Woods, this twenty-sixth day of July, A.D. 1883.

AUGUSTUS LOFTUS.

---

**REPORTS.**

Sir,

We have the honor to return to you herewith the papers connected with an application from Messrs. Harper, Dibbs, and Woods for Letters of Registration for an invention called "Bituminous Concrete," and to report that we have found it necessary to have an interview with the applicants, who thereupon expressed their wish to amend the specification.

Sydney, 21 June, 1883.  
We have, &c.,  
A. LEIBIUS.  
CHAS. WATT.

The Under Secretary of Justice.

Sir,

The amended specification accompanying the Petition of Messrs. Harper, Dibbs, and Woods for Letters of Registration for an invention called "Bituminous Concrete" having been submitted to us, we have examined the same, and have now the honor to report that we see no objection to the issue of Letters of Registration in accordance with the specification and claims.

Sydney, 25 June, 1883.  
We have, &c.,  
A. LEIBIUS.  
CHAS. WATT.

The Under Secretary of Justice.

---

**No. 1279.**

[Assignment of No. 1093. See Letters of Registration, for 1882, page 247.]





A.D. 1883, 6th August. No. 1280.

IMPROVEMENTS IN THE TREATMENT OF GOLD AND SILVER ORES.

LETTERS OF REGISTRATION to William John Tanner, for Improvements in the treatment of Gold and Silver Ores by the combined action of Electricity and Water, and in Apparatus for the purpose.

[Registered on the 7th day of August, 1883, in pursuance of the Act 16 Vic. No. 21.]

BY HIS EXCELLENCY THE RIGHT HONORABLE SIR AUGUSTUS WILLIAM FREDERICK SPENCER LOFTUS (commonly called LORD AUGUSTUS LOFTUS), Knight Grand Cross of the Most Honorable Order of the Bath, a Member of Her Majesty's Most Honorable Privy Council, Governor and Commander-in-Chief of the Colony of New South Wales and its dependencies.

TO ALL TO WHOM THESE PRESENTS SHALL COME, greeting :

WHEREAS WILLIAM JOHN TANNER, of London, England, gentleman, hath by his Petition humbly represented to me that he is the author or designer of a certain invention or improvement in manufactures, that is to say, of an invention entitled "Improvements in the treatment of Gold and Silver Ores by the combined action of Electricity and Water, and in Apparatus for the purpose," which is more particularly described in the specification and sheet of drawings which are hereunto annexed; and that he, the said petitioner, hath deposited with the Honorable the Treasurer of the said Colony of New South Wales the sum of Twenty Pounds sterling for defraying the expense of granting these Letters of Registration, as required by the Act of Council sixteenth Victoria, number twenty-four; and hath humbly prayed that I would be pleased to grant Letters of Registration whereby the exclusive enjoyment and advantage of the said invention or improvement might be secured to him for a period of fourteen years; And I, being willing to give encouragement to all inventions and improvements in the arts or manufactures which may be for the public good, and having received a report favourable to the prayer of the said Petition from competent persons appointed by me to examine and consider the matters stated therein and to report thereon for my information, am pleased, with the advice of the Executive Council, and in exercise of the power and authority given to me by the said Act of Council, to grant, and do by these Letters of Registration grant unto the said William John Tanner, his executors, administrators, and assigns, the exclusive enjoyment and advantage of the said invention or improvement for and during the term of fourteen years from the date hereof to have, hold, and exercise unto the said William John Tanner, his executors, administrators, and assigns, the exclusive enjoyment and advantage thereof for and during and unto the full end and term of fourteen years from the date of these presents next and immediately ensuing and fully to be complete and ended: Provided always, that if the said William John Tanner shall not, within three days after the granting of these Letters of Registration, register the same in the proper office in the Supreme Court at Sydney, in the said Colony of New South Wales, then these Letters of Registration and all advantages whatsoever hereby granted shall cease and become void.

In witness whereof, I have hereunto set my sign manual, and have caused the present Letters of Registration to be sealed with the seal of the said Colony of New South Wales, at Government House, Sydney, in New South Wales, this sixth day of August, in the year of our Lord one thousand eight hundred and eighty-three.

[L.S.]

AUGUSTUS LOFTUS.

*Improvements in the treatment of Gold and Silver Ores.*

SPECIFICATION of WILLIAM JOHN TANNER, of London, England, gentleman, for an invention entitled "Improvements in the treatment of Gold and Silver Ores by the combined action of Electricity and Water, and in Apparatus employed for the purpose."

MY invention relates to an improved method of treating gold and silver ores with the object of effecting wholly or partially the required disintegration of the substances treated, by the combined action of electricity and water, and to apparatus employed for that purpose.

In carrying out my invention, I construct a vessel or receptacle of any shape or size, and of any material, whether the same be a conductor of electricity or not, and I connect the vessel with either the positive or the negative pole of the source of electricity. In the case of the vessel or receptacle being a conductor of electricity, I make such vessel answer the purpose of the negative pole (or cathode), by attaching the same to the negative pole of the battery or other source of electricity, such vessel being stationary or movable; and in case of the vessel not being a conductor of electricity, I place within such vessel, either at the bottom or sides thereof, or in any other convenient position, suitable electric conductors according to the nature of the ore to be treated, such conductors being in the form of plates, bars, rods, or the like, and either stationary or movable, and I connect the same to the negative pole of the battery or other source of electricity.

I place inside the vessel copper plates, bands, rods, wires (movable or stationary), or other suitable electric conductors, and I connect such conductors with the positive pole of the battery or other source of electricity, thus making such copper rods, plates, bands, or wires the anode.

The anode herein described must not directly touch or come into contact with the negative pole or cathode, as hereinbefore described, but may be above, or at the side, within, or around the same.

The vessel must be filled, either wholly or partially with water, so that the electricity is carried from one pole to the other through and by means of the water, so that the positive and negative poles of the battery, or other source of electricity, which had not been in circuit before shall be joined by the intervention of a stratum of water.

With the water contained in the vessel I place the metallic ore, after the same has been ground or pulverized, allowing it to be moved by stirrers or not.

The water may be allowed to remain in the vessel, or a stream of water may be kept flowing through it.

By employing the electric current, as herein described, each individual unit or particle of the ground or pulverized ore is acted upon by the electricity contained in the water, and this tends to decompose or disintegrate the substances acted upon, an addition of an acid in the water will, as is well known, increase the energy of the electricity.

By this treatment, the expensive and laborious processes now in use for the reduction of gold and silver ores into their component parts are greatly facilitated, thus rendering the final separation easy by the most simple processes in use.

I now proceed, with reference to the accompanying drawings, to describe apparatus for carrying out my invention.

In figure 1, which is a longitudinal section of one form of apparatus, the ore to be operated upon together with the necessary quantity of water, is introduced into the drum-shaped vessel, A, through the sliding door, B. The vessel A is made of a non-conducting material, and is wholly or partially lined with a conducting material. In the drawing, the vessel is shown partially lined with copper strips, C, which are slidden into groves cut in the inner surface of the vessel, and are held in place by the copper bands, DD. The vessel A is revolved in the bearings EE' by the pulley F. On the outside of the vessel is placed a copper band or hoop, G, exactly over one of the inner bands DD; and copper screws, H, are passed through the band or hoop G and body of the drum A into the inner band D. As the drum revolves, the outer band or hoop G presses in contact with an ordinary copper brush connected with the positive pole of a battery, or other source of electricity, and the electric current passes through the outer band or hoop and the copper screws HH into the inner band, and from this is distributed all over the inner surface of the drum by the strips of copper, CCC.

Inside the drum is a helicoidal piece of metal, JJ, which is hung on the shaft K. This shaft is let into a socket, L, at one end, and runs through the stuffing box M into the bearing N at the other end. The shaft and the helicoidal piece, J, may be revolved, if thought necessary, by the pulley O. The negative pole of the battery, or other source of electricity, is connected with the shaft K, and the current passes through it to the helicoidal piece inside the drum.

By removing the bearings, E and N, and the pulleys, F and O, which are made in halves, so as to be readily taken off, the helicoidal piece J can be drawn out of the vessel through the removable end P of the drum A.

In figure 2, which is a longitudinal section of another form of apparatus, the material to be operated upon is placed in the pan or vessel A, which is made either entirely of a good conductor, or of some non-conducting material lined wholly or partially with a conductor. The drawing shows the pan or vessel A, made entirely of a conducting material. In the centre of this pan or vessel is fixed the non-conducting sleeve B, which is passed over the rod C. This rod is screwed into and forms part of the shaft D, which is fixed to the ball E working in the socket F. The parts D, E, and F are made of a good conducting material, and are connected with the positive pole of a battery or other source of electricity, and the current passes through the rod C to the radial arms GG, and passes out and is distributed in all directions through the ore and water contained in the pan or vessel by the tines, H. These tines H are set at any desired angle to the arms, and are so fitted on the arms that no two tines are at the same distance from the centre of the pan or vessel. At the bottom of the pan or vessel is fixed the ring, K, which is made of copper, and is connected with the pan or its lining by means of the copper screws, J.

The pan or vessel A is revolved by the bevil wheels L and M. On the upper surface of the wheel M is a socket O, placed away from the centre of the wheel towards the periphery, in which the end of the shaft P works freely. This shaft P is made of a bad conducting metal, and is fitted into the ball E, so that the axis of P, D, C, is identical. The object of placing the socket O away from the centre is to give the pan or vessel a wabbling motion during its revolution, and thus further to agitate the ore and water contained in it.

As

*Improvements in the treatment of Gold and Silver Ores.*

As the pan or vessel revolves, the ring K runs on another ring Q, fixed on the top of the table R, but separated from it by a slab of non-conducting material, S. The ring Q is connected with the negative pole of the battery, or other source of electricity; and as the ring K on the bottom of the pan or vessel is always in contact with it at one point, the electric current passes through it to the pan or vessel, and is thus distributed over its surface.

The space between the ring Q and socket F is also filled with a non-conducting material.

In figure 3, which is a vertical section of another form of apparatus, the material to be operated upon is put into the vessel A, which is made of a non-conducting material. This vessel is wholly or partially lined with a conducting material, B, and the lining is connected with the negative pole of the battery or other source of electricity. Passing centrally through the vessel A, and fixed to the bottom thereof, is a rod, C, over which is placed a sleeve, D, made of a conducting material, and this rod passes through the collar E, and is attached to two or more arms, F, which are fastened to the sides of the vessel A. The sleeve D is turned round the central rod C of the pulley G, and carries with it as it revolves the radial arms HH, to which are fixed the hanging tines J, which are set at an angle with the arms, and always so that they never move in each other's track. The sleeve D being connected with the positive pole of the battery or other source of electricity, the current passes through it and the arms H, and out through the tines J, and is thus distributed through the ore and water contained in the vessel A.

In order to raise the arms H to any desired height within the vessel A, and also to prevent the sleeve D slipping down and bringing the tines J into contact with the bottom of the vessel, the sleeve has an internal screw thread cut at its upper end, inside which the screw K works, the bottom of it always resting on the top of the rod C; and by turning the screw K, the sleeve, together with the arms, H, is raised or lowered to the desired distance from the bottom of the vessel.

In figures 4, 5, and 6, which show respectively a longitudinal section, a plan, and a cross-section (on line *bb* of fig. 1), the ore and water to be operated upon are put into the semicircular-bottomed vessel A, which is made of a non-conducting material, and wholly or partially lined with a good conductor of electricity connected with the negative pole of a battery or other source of electricity. The shaft B, to which is fastened the stirrers, C, passes longitudinally through the vessel A. This shaft and its stirrers are made of a good conductor of electricity, and are caused to revolve by means of the pulley D. This shaft is connected with the positive pole of a battery or other source of electricity, and the current passes through it and out through the stirrers C, and is thus distributed throughout the material contained in the vessel A.

In order to remove any film or scum which may arise during the agitation of the ore and water, the vessel A has one of its ends, E, made lower than the two sides and the opposite end; outside the lower end E is constructed the trough F, having a sloping bottom G and an open end J, and when it is required to remove the film or scum, sufficient water is passed into the vessel through the pipe H to bring the level of the ore and water contained in A above the height of the end E, and the excess of material having no other means of escape passes over the lower end E into the trough F, and out through the open end J, carrying with it all the film or scum.

Having now described the construction and operation of my invention, I claim and desire to secure by Letters Patent—

1. The herein described method of treating gold and silver ores by the combined action of electricity and water, for the purpose of effecting wholly or partially the disintegration of the same, substantially as set forth.
2. The construction and use of apparatus such as herein described and illustrated in figure 1 of the drawings, for the purpose of effecting the disintegration of gold and silver from their ores, in the manner above indicated.
3. The construction and use of apparatus such as herein described and illustrated in figure 2 of the drawings, for the purpose of effecting the disintegration of gold and silver from their ores, in the manner above described.
4. The construction and use of apparatus such as herein described and illustrated in figure 3, of the drawings, for the purpose of effecting the disintegration of gold and silver from their ores, in the manner above indicated.
5. The construction and use of apparatus such as herein described and illustrated in figures 4, 5, and 6 of the drawings, for the purpose of effecting the disintegration of gold and silver from their ores, in the manner above indicated.

In witness whereof, I, the said William John Tanner, have hereunto set my hand and seal, this eighteenth day of April, A.D. 1883.

WILLIAM JOHN TANNER.

This is the specification referred to in the annexed Letters of Registration granted to William John Tanner, this sixth day of August, A.D. 1883.

AUGUSTUS LOFTUS.

### REPORT.

Sir,

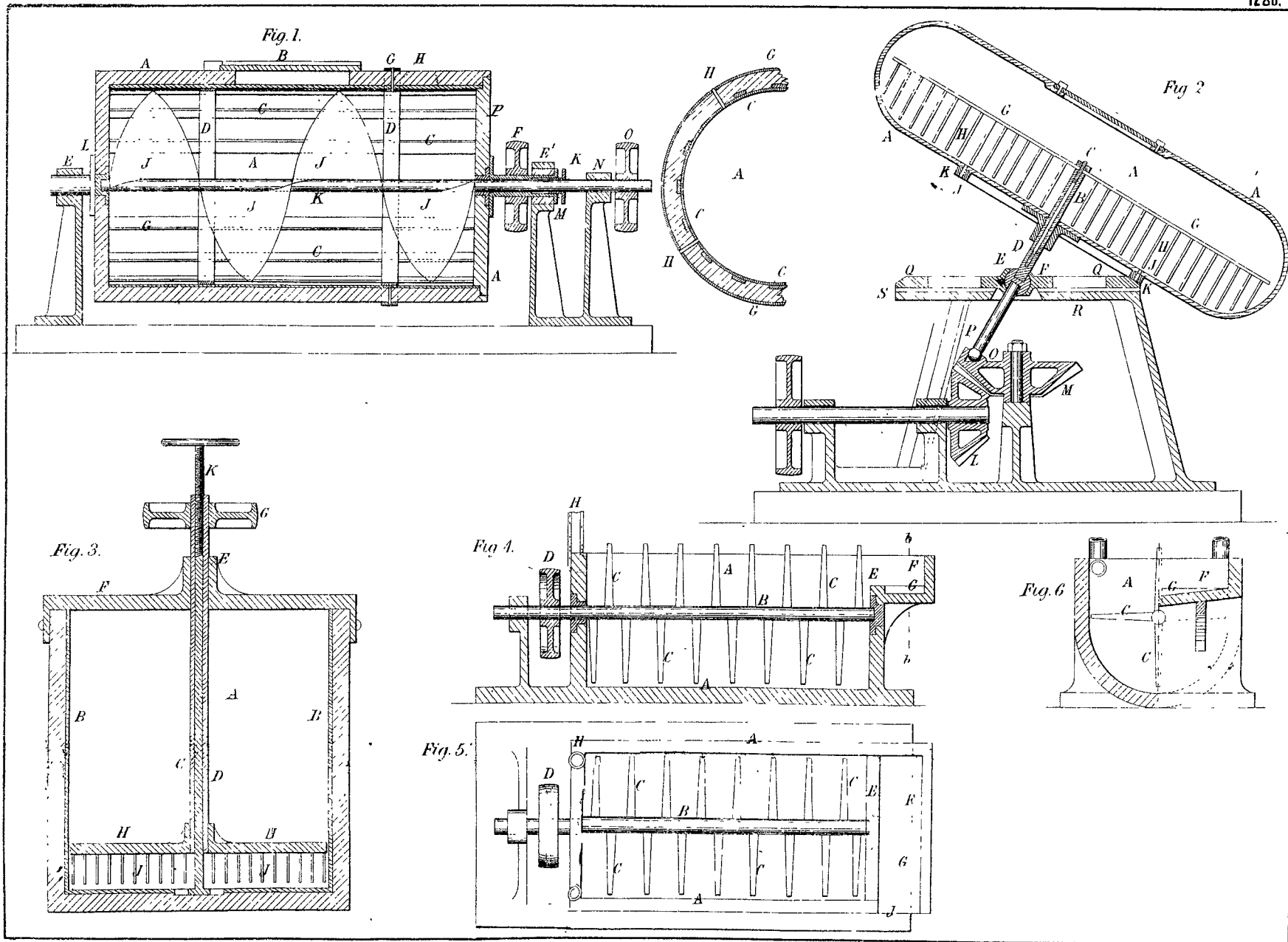
Sydney, 13 June, 1883.

The Petition of Mr. William John Tanner for Letters of Registration for an invention entitled "Improvements in the treatment of Gold and Silver Ores by the combined action of Electricity and Water, and in Apparatus for the purpose," having been referred to us, we have the honor to report that we see no objection to the issue of Letters of Registration as prayed for.

We have, &c.,

A. LEIBIUS.  
CHAS. WATT.

The Under Secretary of Justice.



*This is the Sheet of Drawings referred to in the annexed Letters of Registration granted to William John Turner, this sixth day of August A. D. 1883.*

*Augustus Loftus.*

PHOTO-LITHOGRAPHED AT THE GOVT. PRINTING OFFICE, SYDNEY, NEW SOUTH WALES.

(*Fig. 35.*)




---

A.D. 1883, 6th August. No. 1281.

---

AN IMPROVED EXCAVATOR OR DIGGER.

LETTERS OF REGISTRATION to Benjamin Barnes, for an Invention entitled  
 "An Improved Excavator or Digger."

[Registered on the 7th day of August, 1883, in pursuance of the Act 16 Vic. No. 24.]

BY HIS EXCELLENCY THE RIGHT HONORABLE SIR AUGUSTUS WILLIAM FREDERICK SPENCER LOFTUS  
 (commonly called LORD AUGUSTUS LOFTUS), Knight Grand Cross of the Most Honorable Order of  
 the Bath, a Member of Her Majesty's Most Honorable Privy Council, Governor and Commander-in-  
 Chief of the Colony of New South Wales and its Dependencies.

TO ALL TO WHOM THESE PRESENTS SHALL COME, greeting:

WHEREAS BENJAMIN BARNES, of Dubbo, in the Colony of New South Wales, engineer and contractor, hath by his Petition humbly represented to me that he is the author or designer of a certain invention or improvement in manufactures, that is to say, of an invention entitled "An Improved Excavator or Digger," which is more particularly described in the specification and the sheet of drawings which are hereunto annexed; and that he, the said Petitioner, hath deposited with the Honorable the Treasurer of the said Colony of New South Wales the sum of Twenty Pounds sterling for defraying the expense of granting these Letters of Registration, as required by the Act of Council sixteenth Victoria, number twenty-four; and hath humbly prayed that I would be pleased to grant Letters of Registration, whereby the exclusive enjoyment and advantage of the said invention or improvement might be secured to him for a period of fourteen years: And I, being willing to give encouragement to all inventions and improvements in the arts or manufactures which may be for the public good, and having received a report favourable to the prayer of the said Petition, from competent persons appointed by me to examine and consider the matters stated therein and to report thereon for my information, am pleased, with the advice of the Executive Council, and in exercise of the power and authority given to me by the said Act of Council, to grant, and do by these Letters of Registration grant unto the said Benjamin Barnes, his executors, administrators, and assigns, the exclusive enjoyment and advantage of the said invention or improvement, for and during the term of fourteen years from the date hereof; to have, hold, and exercise unto the said Benjamin Barnes, his executors, administrators, and assigns, the exclusive enjoyment and advantage thereof, for and during and unto the full end and term of fourteen years from the date of these presents next and immediately ensuing, and fully to be complete and ended: Provided always, that if the said Benjamin Barnes shall not, within three days after the granting of these Letters of Registration, register the same in the proper office in the Supreme Court, at Sydney, in the said Colony of New South Wales, then these Letters of Registration, and all advantages whatsoever hereby granted, shall cease and become void.

In witness whereof, I have hereunto set my sign manual, and have caused the present Letters of Registration to be sealed with the seal of the said Colony of New South Wales, at Government House, Sydney, in New South Wales, this sixth day of August, in the year of our Lord one thousand eight hundred and eighty-three.

AUGUSTUS LOFTUS.

*An Improved Excavator or Digger.*

SPECIFICATION of BENJAMIN BARNES, of Dubbo, in the Colony of New South Wales, engineer and contractor, for an invention entitled "An Improved Excavator or Digger."

THE invention has been designed for the purpose of providing a simple and convenient apparatus for excavating and raising earth, sand, gravel, or clay, or any similar material, and which is intended to be used in sinking cylinders, digging wells, or any similar kind of work, more particularly where the digging or excavating is required to be carried on below the surface of the water.

And in order that my invention may be clearly understood, I will now refer to the drawing hereunto annexed, where the similar letters indicate the same parts wherever they occur. AA are scoops, made of iron or steel of the shape and form as shown; BBBB are strong levers, securely fixed to the scoops AA, as shown in figure 3, and arranged to work upon the centre-pin, C; DD are links, the ends of which are bent and fitted to work in holes in the ends of the levers BBBB. These links are connected together by the ring on the end of the chain E. FF are suspending rods, of which there are four. These rods are connected to the scoops by movable joints at the points marked FFFF on figure 3, and as shown on figures 1 and 2. Each of these suspending rods has an eye on its top end; and they are held together by the pin and shackle G. H is a trip-hook, made of round iron of the form shown, having a loop L, and working loosely upon the shackle G; J is a chain and hook required in manipulating the apparatus; K is a rope to which the chain is attached, and which is connected with any suitable winding gear for raising and lowering the excavator.

The way of working my invention is as follows:—In figure 1 the trip-hook, to which the suspension-rods are attached by the shackle G—J, is shown hooked into a link at the top end of the chain E. The point of suspension of the scoops and levers being then so near the end of the levers, their weight causes them to fall forward, and to throw the scoops wide apart, with the ends of the levers resting upon their edge. The apparatus is then lowered by the rope K into the material to be excavated, when the trip-hook falls down and becomes disconnected; the rope then being drawn up, the point of suspension is transferred by the chain E and the links DD to the ends of the levers BBBB, and the scoops are drawn together as shown in figure 2, and a quantity of the material to be excavated taken up. When the apparatus is raised to the required height, the loop of the trip-hook is placed upon the hook J; and when the excavator is lowered, the weight is again suspended by the rods, when the weight of the levers causes them again to fall forward, and the scoops discharge their contents. The trip-hook is then hooked into the link at the top of the chain E, and the rope being drawn up, the hook J is taken from the loop in the trip-hook, when the excavator is again ready to be lowered into the earth to be excavated.

The scoops may be made concave, or curved at the back, but I prefer them as shown, as they will be found effective, and are of simple construction. To make the excavator penetrate the material more effectually, iron or lead weights are bolted on the inside of the scoops at the top edge, and between the suspension-rods. And when the earth requires breaking up, wrought-iron steel-pointed picks, of the form as shown in dotted lines at M, are secured by screw or cotter bolts to the edge of the scoops.

What I claim in this, my invention, is the combined lever and scoop—coupled with changing of the points of suspension in the manner shown, to effect the opening and shutting motions. I also claim this general arrangement of parts in producing a simple and useful excavator.

The advantages are that it is simple in construction; that it is easily manipulated; that an ordinary blacksmith can effect repairs to any part of it; and that it is easily conveyed to places difficult of access, and may be worked to great advantage by any portable winding engine of from four- to six-horse power.

In witness whereof, I, the said Benjamin Barnes, have hereunto set my hand and seal, this second day of June, one thousand eight hundred and eighty-three.

BENJAMIN BARNES.

This is the specification referred to in the annexed Letters of Registration granted to Benjamin Barnes, this sixth day of August, A.D. 1883.

AUGUSTUS LOFTUS.

---

REPORT.

Sir,

In reply to your B.C. Minute of the 9th instant, forwarding the application of Benjamin Barnes for protection of an invention entitled "An improved Excavator or Digger," we are of opinion that letters of Registration might be issued for the protection of such invention.

We have, &c.,

JAMES BARNET.  
WILLIAM C. BENNETT.

The Under Secretary of Justice.

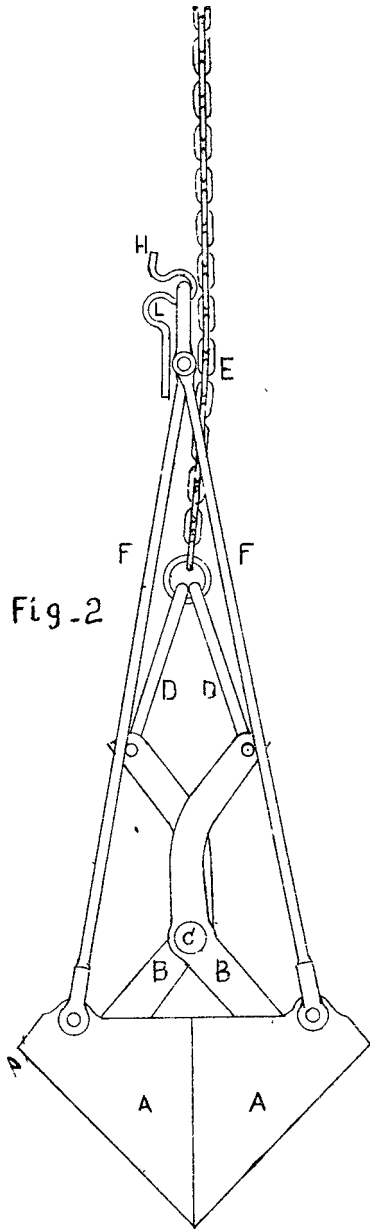


Fig-2

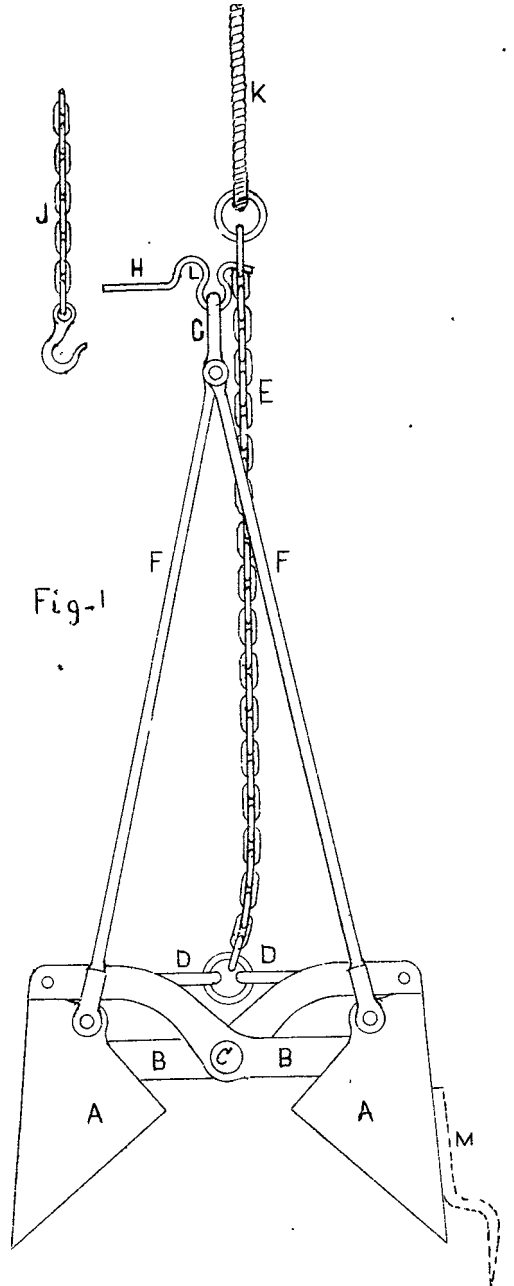


Fig-1

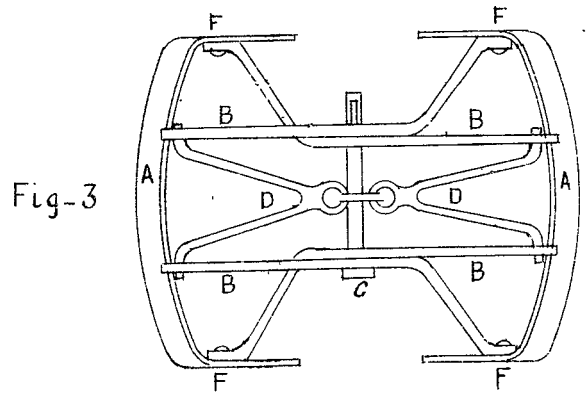


Fig-3

— Plan of levers and scoops —

*This is the Sheet of Drawings referred to in the annexed Letters of Registration granted to Benjamin Barnes, this sixth day of August, A.D. 1883.*

*(Sig 35)*

*Augustus Loftus.*

*Benjamin Barnes*



A.D. 1883, 6th August. No. 1282.

**IMPROVEMENTS IN THE TREATMENT OF COPPER ORES, &c.**

**LETTERS OF REGISTRATION** granted to Pierre Manhes, for an Invention entitled "Improvements in the treatment of Copper Ores and other Cupreous Materials for the obtainment of Copper therefrom, and in Refining impure Copper, and in the Apparatus to be employed in the said treatment."

[Registered on the 7th day of August, 1883, in pursuance of the Act 16 Vic. No. 24.]

BY HIS EXCELLENCY THE RIGHT HONORABLE SIR AUGUSTUS WILLIAM FREDERICK SPENCER LOFTUS (commonly called LORD AUGUSTUS LOFTUS), Knight Grand Cross of the Most Honorable Order of the Bath, a Member of Her Majesty's Most Honorable Privy Council, Governor and Commander-in-Chief of the Colony of New South Wales and its dependencies.

TO ALL TO WHOM THESE PRESENTS SHALL COME, greeting :

WHEREAS PIERRE MANHES, of Paris, in the Republic of France, hath by his Petition humbly represented to me that he is the author or designer of a certain invention or improvement in manufactures, that is to say, of an invention entitled "Improvements in the treatment of Copper Ores and other Cupreous Materials for the obtainment of Copper therefrom, and in refining impure Copper, and in the Apparatus to be employed in the said treatment," and which is more particularly described in the specification which is hereunto annexed; and that he, the said Petitioner, hath deposited with the Honorable the Treasurer of the said Colony of New South Wales the sum of Twenty Pounds sterling, for defraying the expense of granting these Letters of Registration, as required by the Act of Council, sixteenth Victoria, number twenty-four, and hath humbly prayed that I would be pleased to grant Letters of Registration, whereby the exclusive enjoyment and advantage of the said invention or improvement might be secured to him for a period of fourteen years; And I, being willing to give encouragement to all inventions and improvements in the arts or manufactures which may be for the public good, and having received a report favourable to the prayer of the said Petition, from competent persons appointed by me to examine and consider the matters stated therein and to report thereon for my information, am pleased, with the advice of the Executive Council, and in exercise of the power and authority given to me by the said Act of Council, to grant, and do, by these Letters of Registration grant unto the said Pierre Manhes, his executors, administrators, and assigns, the exclusive enjoyment and advantage of the said invention or improvement for and during the term of fourteen years from the date hereof; to have, hold, and exercise unto the said Pierre Manhes, his executors, administrators, and assigns, the exclusive enjoyment and advantage thereof, for and during and unto the full end and term of fourteen years from the date of these presents next and immediately ensuing, and fully to be complete and ended: Provided always, that if the said Pierre Manhes shall not, within three days after the granting of these Letters of Registration, register the same in the proper office in the Supreme Court, at Sydney, in the said Colony of New South Wales, then these Letters of Registration, and all advantages whatsoever hereby granted, shall cease and become void.

In witness whereof, I have hereunto set my sign manual, and have caused the present Letters of Registration to be sealed with the seal of the said Colony of New South Wales, at Government House, Sydney, in New South Wales, this sixth day of August, in the year of our Lord one thousand eight hundred and eighty-three.

[L.s.]

AUGUSTUS LOFTUS.



*Improvements in the treatment of Copper Ores, &c.*

SPECIFICATION of PIERRE MANHES, of Paris, in the Republic of France, for Improvements in the treatment of Copper Ores and other Cupreous Materials for the obtainment of Copper therefrom, and in refining impure Copper, and in the Apparatus to be employed in the said treatment.

My invention relating to improvements in the treatment of copper ores and cupreous materials by means of air injected into the molten metal is carried out in practice by the aid of apparatus constructed on the same principle as those known as "Bessemer" converters, or in other equivalent revolving or stationary apparatus arranged to admit of air being injected into the fused mass.

The said improvements not only enable crude or unrefined copper to be obtained from ores containing sulphur and iron or other oxidizable or volatile metals, but also enable malleable and refined copper ready for the market to be obtained at one operation by means of the apparatus hereinbefore referred to, and this, either by acting directly on impure ores or upon unrefined copper or other cupreous materials or refuse.

When the said copper or cupreous materials under treatment do not contain a sufficient quantity of matter capable of supporting combustion, the treatment may be performed advantageously by adding to these materials a sufficient quantity of substances capable of elevating the temperature of the mass by their combustion in presence of injected air. The additional combustible matter that I employ is preferably iron, manganese, or phosphorus, introduced by incorporating cheap materials containing one or more of these substances with the fluid mass.

Ores containing sulphur may be treated without undergoing any preliminary roasting, being roughly melted in a furnace of any convenient construction, but preferably in a cupola or low blast furnace, for the purpose of eliminating the earthy gangues by the formation of a slag or cinder. The metallic portions are thus concentrated into a matt more or less rich in copper, and always containing some iron and a considerable quantity of sulphur.

The liquid matt is run directly from this furnace into a converting vessel previously heated to a suitable temperature and by means of a blast of air injected into the said vessel, the sulphur is eliminated together with the other volatile substances, such as arsenic, antimony, and the like, whilst at the same time the iron is rapidly oxidized and converted into silicate of iron by contact with the earthy matter which forms the lining of the converter, and if necessary, by the addition of silicious fluxes. The scoria formed is removed in the usual manner. The operation occupies a short time, and when concluded, the crude copper is run out either in cakes or preferably into a refining furnace previously heated, in order to avoid the necessity of remelting the metal.

When it is desired to obtain in one operation refined malleable copper ready for the market, the process is carried out as next hereinafter described.

After treatment as hereinbefore described in the converter, the slag or scoria floating at the surface is run off or drawn off with a robble, and a sample of the metal is taken out in a ladle and broken. If the fracture be of a reddish violet colour and of a coarse granular appearance, showing that the copper contains a certain proportion of protoxide, this may be taken as a positive indication that the foreign matter is completely eliminated. If, on the other hand, the sample does not present indications of being pure copper, the blast must be again turned on in the converter and the progress of the oxidation ascertained, taking samples. A few minutes will then suffice to eliminate the last trace of impurities.

In order to prevent the metal from solidifying in the converter during the refining process, owing to the exhaustion of the matter which supported combustion, a small quantity of pulverized sulphur or carbon, or other suitable materials may be injected along with the blast to maintain the requisite heat. It is preferable to employ sulphur for this purpose, as it does not materially interfere with the oxidation of the metallic matter, there being always a large excess of oxygen in the blast.

In order to finally reduce the protoxide with which the copper is contaminated, the surface of the metal is again cleared, and fragments of wood charcoal are introduced into the mouth of the converter, so as to cover the metal. Pulverized wood charcoal is then injected along with the blast, and exerts a powerful reducing action, raising the temperature of the metal considerably, and maintaining it sufficiently hot until the operation is completed, the progress of the reduction being ascertained from time to time by taking samples. When the copper commences to present a closer grain and a paler colour, the blast is stopped, and the refining operation is then completed in the usual manner by the introduction of a staff of green wood. The refined copper is then ready to be cast into ingots.

This improved method of refining copper by the employment of a vessel on the principle of the Bessemer converter enables large quantities of copper to be expeditiously and effectually refined, and being performed without special fuel is very economical in practice.

This process is applicable to the refining of all descriptions of unrefined metallic copper obtained by treating cupreous matts in any convenient manner, which simply require melting in order to prepare them for the converter. The results obtained by this improved mode of refining impure copper are very superior to those obtained by the ordinary treatment. Not only may sulphurous copper ores, matts, regulus, and the like be treated very economically by means of this invention, but also oxidized, carbonated, and other like cupreous ores and materials may be treated with great advantage by first converting them into matts by a preliminary fusion with sulphur. It is evident that bronze, old tinned copper, and other impure copper containing neither sulphur nor iron, may thus be refined by injecting pulverised sulphur or carbon into the converter along with the blast.

The scoria from the converter always contains some copper in the condition of oxide or in grains, and may be sifted to separate the richer portion, which is subjected to a subsequent treatment to extract the metallic copper therefrom. I prefer to melt these materials in a low blast furnace, with suitable fluxes, in order to obtain a red copper and a scoria containing so little metal as not to be worth preserving.

Nevertheless, this scoria, being always very rich in oxide of iron, may be advantageously employed as a flux in the fusion of ores and other quartzose matters.

When the matts contain much iron, which would be liable to attack the ordinary earthy lining of the converter, it is advisable to prepare this lining with a basic substance, such as lime, magnesia, or the like, and to use a silicious flux capable of scorifying the oxides produced.

For

*Improvements in the treatment of Copper Ores, &c.*

For carrying out the treatment hereinbefore described, I have indicated the employment of a Bessemer converter by preference, as this apparatus is well adapted to obtain the effects of the intermolecular combustion, which is the basis of the treatment; but in order to conduct the operation in the most advantageous manner, it is desirable to arrange the converting vessel in a special manner, as hereinafter described.

The metallic copper, by reason of its density, collects at the bottom of the converter as fast as it is produced, and if the blast were injected on a level with the bottom through vertical tuyeres, as in the case of the converters usually employed in treating iron, the air would, as the operation approached completion, be compelled to pass through a mass of metallic copper, not containing the elements necessary to support combustion, and consequently liable, under the cooling action of the blast, to solidify and choke the tuyeres. This inconvenience might be obviated by previously heating the blast; but this method is expensive and open to many objections in practice, whereas the arrangement hereinafter described enables the desired result to be obtained in the most advantageous manner.

The said arrangement, which may be modified in various ways as regards its details, consists in providing a clear space below the orifices of the tuyeres for the reception of the metallic copper. The internal capacity of this space should be equal to or slightly greater than the space actually occupied by the copper resulting from the operation, and which is thus effectually protected from the action of the cold blast.

In order to obtain this result, I prefer to employ horizontal tuyeres opening into the converter at a suitable distance from the bottom, in place of the vertical tuyeres delivering the blast at the bottom, as in the case of ordinary Bessemer converters.

The effect of this arrangement is, that as the blast acts only upon the matter containing combustible elements, the tuyeres are not liable to become choked by the cooling of the metal.

## CLAIMS.

1. The improvements in the treatment of copper ores and other cupreous materials, substantially as and for the purposes hereinbefore described.
2. Treating copper ores and other cupreous materials in a "Bessemer" converter or other fixed or rotary converting vessel or chamber, by the introduction into the mass of a blast of air and combustible matter, substantially as and for the purposes hereinbefore described.
3. In apparatus for the treatment of copper ores and other cupreous materials, according to the process hereinbefore described and claimed, arranging the tuyeres of the converting vessel as hereinbefore described, so that the metallic copper resulting from the treatment is protected from the action of the blast.
4. Refining impure copper or cupreous alloys containing no combustible matter, by subjecting the said copper to treatment in a converting vessel, substantially as hereinbefore described.

In witness whereof, I, the said Pierre Manhes, have to this my specification set my hand and seal, this twenty-fifth day of April, one thousand eight hundred and eighty-three.

PIERRE MANHES.

Signed and sealed in the presence of—

C. GAVEL, dessinateur,  
rue de l'Hotel-de-ville 31, Lyons.

JOSEPH CHAMANTON,  
Clerk to Consul, 1 quai St. Clair, Lyons.

Attested,—Lyons, 25th April, 1883.

CHARLES S. HADEN,  
H.B.M. Vice-Consul.

This is the specification referred to in the annexed Letters of Registration granted to Pierre Manhes, this sixth day of August, A.D., 1883.

AUGUSTUS LOFTUS.

## REPORT.

Sir,

Sydney, 21 June, 1883.

The application of Mr. Pierre Manhes for Letters of Registration for an invention entitled "Improvements in the treatment of Copper Ores and other Cupreous Materials for the obtainment of Copper therefrom, and in refining impure Copper, and in the Apparatus to be employed in the said treatment," having been referred to us, we have examined the specification accompanying the same, and have the honor to report that we see no objection to the issue of Letters of Registration as prayed for.

We have, &c.,  
A. LEIBIUS.  
CHAS. WATT.

The Under Secretary of Justice.



A.D. 1883, 8th August. No. 1283.

IMPROVEMENTS IN SECONDARY OR STORAGE BATTERIES.

LETTERS OF REGISTRATION granted to Desmond Gerald FitzGerald and Thomas John Jones for an invention entitled "Improvements in Secondary or Storage Batteries."

[Registered on the 10th day of August, 1883, in pursuance of the Act 16 Vic. No. 24.]

BY HIS EXCELLENCY the RIGHT HONORABLE SIR AUGUSTUS WILLIAM FREDERICK SPENCER LOFTUS (commonly called LORD AUGUSTUS LOFTUS), Knight Grand Cross of the Most Honorable Order of the Bath, a Member of Her Majesty's Most Honorable Privy Council, Governor and Commander-in-Chief of the Colony of New South Wales and its Dependencies.

TO ALL TO WHOM THESE PRESENTS SHALL COME, greeting :

WHEREAS DESMOND GERALD FITZGERALD, of Brixton, in the County of Surrey, England, electrician, and THOMAS JOHN JONES, of Princes-street, Hanover Square, London, England, electrician, have by their Petition humbly represented to me that they are the authors or designers of a certain invention or improvement in manufactures, that is to say, of an invention entitled "Improvements in Secondary or Storage Batteries," which is more particularly described in the specification which is hereunto annexed; and that they, the said Petitioners, have deposited with the Honorable the Treasurer of the said Colony of New South Wales the sum of Twenty Pounds sterling, for defraying the expense of granting these Letters of Registration, as required by the Act of Council, sixteenth Victoria, number twenty-four; and have humbly prayed that I would be pleased to grant Letters of Registration, whereby the exclusive enjoyment and advantage of the said invention or improvement might be secured to them for a period of fourteen years: And I, being willing to give encouragement to all inventions and improvements in the arts and manufactures which may be for the public good, and having received a report favourable to the prayer of the said Petition, from competent persons appointed by me to examine and consider the matters stated therein and to report thereon for my information, am pleased, with the advice of the Executive Council, and in exercise of the power and authority given to me by the said Act of Council, to grant, and do by these Letters of Registration grant unto the said Desmond Gerald FitzGerald and Thomas John Jones, their executors, administrators, and assigns, the exclusive enjoyment and advantage of the said invention or improvement, for and during the term of fourteen years from the date hereof; to have, hold, and exercise unto the said Desmond Gerald FitzGerald and Thomas John Jones, their executors, administrators, and assigns, the exclusive enjoyment and advantage thereof, for and during and unto the full end and term of fourteen years from the date of these presents next and immediately ensuing, and fully to be complete and ended: Provided always that if the said Desmond Gerald FitzGerald and Thomas John Jones shall not, within three days after the granting of these Letters of Registration, register the same in the proper office in the Supreme Court, at Sydney, in the said Colony of New South Wales, then these Letters of Registration, and all advantages whatsoever hereby granted, shall cease and become void.

In witness whereof, I have hereunto set my sign manual, and have caused the present Letters of Registration to be sealed with the seal of the said Colony of New South Wales, at Government House, Sydney, in New South Wales, this eighth day of August, in the year of our Lord one thousand eight hundred and eighty-three.

[L.S.]

AUGUSTUS LOFTUS.

*Improvements in Secondary or Storage Batteries.*

SPECIFICATION of DESMOND GERALD FITZGERALD, of Brixton, in the County of Surrey, electrician, and THOMAS JOHN JONES, of Princes-street, Hanover Square, London, electrician, entitled "Improvements in Secondary or Storage Batteries."

IN constructing secondary batteries according to our invention, we employ carbon in conjunction with finely divided lead, or an oxide or insoluble salt of this metal, as the electrode which is to constitute the cathode in charging (or strictly speaking the support for the reduced metal which becomes the cathode) and the anode in discharging, the secondary battery. The limitation of the use of carbon to this electrode is the main point of novelty and utility in the present invention, which has no reference to secondary batteries constructed with carbon as the material mainly entering into the composition of both electrodes, in accordance with the methods which have hitherto been suggested for utilizing carbon in secondary batteries, which methods we have found to be ineffective and impracticable by experimental trials extending over a considerable period of time.

For the electrode which is to constitute the anode in charging, or the cathode in discharging, the battery, we preferably employ metallic lead in conjunction with the same metal in a finely divided (but non-compressed) condition, or with an oxide or insoluble salt of this metal; but although we hereinafter specify certain electrodes which we have found to be effective as anodes (in charging) when employed in conjunction with our carbon cathodes, we would have it understood that we do not limit ourselves to, or claim as novel, the anodes thus specified, but that we use carbon as the cathode (in charging) in conjunction with any suitable anode.

We will now proceed particularly to describe and specify the modes in which, according to our invention, carbon is employed in the construction of the electrode which is to constitute the cathode (when charging) of our secondary batteries. We take rods or plates of gas carbon, or of any other kind of carbon which does not readily become disintegrated, and on one extremity or edge of such rods or plates we cast a cap, or contact-piece, of lead, or any suitable alloy, in which may be imbedded a wire or strip of metal, and we preserve such contact-piece from corrosion, preferably, by means of paraffine-wax, with which the carbon in proximity to such contact-piece is saturated, as is well understood. The rods or plates, of carbon, if sufficiently porous, may be impregnated with metallic lead, or with an oxide or an insoluble salt of lead, by immersing the carbon in a solution of a soluble salt of lead, and, after drying, heating the carbon to low redness, with or without access of air, or heating it with any reagent (such as an alkaline solution or dilute sulphuric acid, or an alkaline sulphate, tartiate, or phosphrate) which will decompose the soluble salt of lead and precipitate oxide, or an insoluble salt of lead, within the pores of the carbon, the process being repeated until a sufficient degree of impregnation has been obtained. In this case the carbon electrodes so treated (more especially if they be grooved, recessed, or perforated) may be employed alone as the cathode in charging, but we prefer to surround the rods or plates of carbon, so impregnated or otherwise, with fragments of carbon, which also may be impregnated with metallic lead, or with an oxide or insoluble salt of lead, in the manner just described, or by electro deposition. The carbon fragments which are to surround the rods or plates of carbon are, in any case, coated either with metallic lead (preferably by electro deposition) or with an oxide of lead (litharge or red lead) or with an insoluble salt of lead, preferably by moistening the fragments with water, or with very dilute sulphuric acid, and agitating them in contact with the oxide or insoluble salt of lead; and, when the carbon fragments are placed into position around the central carbon conductors, the interstices between them may be wholly or in part filled up with the oxide or insoluble salt of lead. To maintain the carbon fragments in contact with the carbon conductors, a casing or diaphragm of felt, or other porous material, may be employed; but we prefer to use a perforated plate, or receptacle of carbon, lead, or other substance, either conducting or non-conducting, which is not detrimentally acted upon by dilute sulphuric acid or other fluid constituting the electrolyte. We have found a rectangular casing, or receptacle, formed of perforated sheet-lead, to answer very effectively the purpose of maintaining the carbon fragments, prepared and coated as described, in contact with the carbon plates or rods. The prepared carbon fragments should be tightly rammed in this receptacle, the latter being placed in a mould for the purpose. In constructing such receptacles the edges of the perforated sheet may be fastened together by means of a folded joint, or by autogenic soldering. The perforations in the sheet-lead, or other material (conducting or non-conducting) of which the receptacle is constructed, may be of any size as will not allow of the passage of the smallest of the carbon fragments employed; but we have found sheet-lead 1-24th inch in thickness, with perforations .065 in diameter, of which there are 120 to the square inch, to answer the required purpose effectively. When the perforated receptacle is of sheet-lead, carbon, or other conducting material, we sometimes dispense with the central plate, or rods of carbon, and employ the receptacle itself as the means of obtaining contact with the carbon fragments. The diaphragm, casing, or receptacle, necessary to maintain the carbon fragments in position, may take the form of a network of any metallic wire not detrimentally acted upon by the electrolyte, or of any suitable non-conducting material, such as gutta-percha or vulcanite. We prefer to construct these electrodes of a flat rectangular form, but they may be made of cylindrical shape, the prepared carbon fragments being, in that case, contained within a perforated cylinder of carbon, lead, or non-conducting material. The central carbon conductor is, in the latter case, essential. We sometimes construct compound electrodes, one surface of which becomes an anode and the other a cathode in charging; such plates being used to divide a trough into cells, as is well understood. In this case, we usually dispense with the carbon fragments, and impregnate with lead, or with an oxide or insoluble salt of lead (as hereinbefore described) a plate of porous carbon, of which one surface is preferably grooved or recessed. To the other surface is cemented, by means of marine glue or other waterproof and insulating cement, a plate of lead brought into good conductive contact with the carbon at a point in what is intended to be the upper edge of the compound plate. Such plate of lead, which may be coated with lead amalgam, or with finely divided lead, or with an oxide or insoluble salt of lead maintained by suitable means in contact with the metal, constitutes the anode surface of the compound plate in charging, the prepared carbon being always the cathode surface in charging.

As

*Improvements in Secondary or Storage Batteries.*

As the anode (in charging) used in conjunction with our carbon cathode, we have employed a plate of lead coated with lead amalgam. But in this case, in order to obviate the effects of disintegration or scaling, it is expedient to use a porous diaphragm of felt, or similar material which is objectionable, not only from its want of durability, but because it adds to the resistance of the battery, and sometimes occasions the short circuiting of a cell. This applies also to anodes formed by maintaining an oxide of lead in contact with a plate of this metal. For this reason we prefer to use an anode consisting of a rectangular receptacle of perforated lead similar to that employed for holding in position the prepared carbon fragments in the cathode element, but of considerably less capacity, although ordinarily of the same height and width and with somewhat smaller perforations, the lead of which it is made being, however, thicker (say) for instance, 1-16th inch. This receptacle is filled with lead in a condition of minute subdivision, or with the chrySTALLINE lead obtained by reducing lead from a soluble salt of the metal, such as the acetate, by means of zinc. Contact with this loosely coherent lead is obtained by means of the lead receptacle. Or, in this case again, the minutely subdivided or chrySTALLINE lead may be contained in a perforated receptacle of any suitable non-conducting material, such as gutta-percha or vulcanite, the contact being established by means of a plate of lead surrounded with the loosely coherent metal. Theoretically, the weight of the minutely subdivided lead entering into the composition of the anode should be less (in about the proportion of 100 to 108) than the weight of oxide of lead surrounding the carbon fragments; but, as the conversion of the former into peroxide of lead is not so complete as the reduction of the latter into metallic lead, and as hydrogen as well as lead is reduced at the cathode, there is no disadvantage in using equal weights of the finely divided lead and oxide of lead respectively at the anode and cathode in charging. When a secondary battery, so constructed with metallic lead at the anode, and an oxide of lead at the cathode (in charging) is first mounted, it is advantageous to short circuit it before proceeding to charge, the result being the formation of some oxide of lead at the anode and some reduced lead at the cathode. If this be not done, a quantity of electricity, double that which is requisite in subsequent chargings, is at first requisite in order to convert the metallic lead at the anode into peroxide of lead. This double quantity of electricity which is required to traverse each cell, is two hundred and thirty-four ampère hours for every pound avoirdupois of finely divided lead used in constructing the anode of the cell. In subsequent chargings half this quantity, or 117 ampère hours, is required for every pound of active lead at the anode surface.

Having thus described the nature of our invention, and the manner of performing the same, we declare that what we claim as our invention is—

The construction and use of secondary batteries, having the electrode, which constitutes the cathode in charging the battery, made of carbon, in conjunction with finely divided lead or an oxide or insoluble salt of this metal, and having the other electrode made of a substance other than carbon, substantially as specified.

In witness whereof, we, the said Desmond Gerald FitzGerald and Thomas John Jones, have hereto set our hands and seals, this nineteenth day of April, 1883.

DESMOND G. FITZGERALD.

T. J. JONES.

This is the specification referred to in the annexed Letters of Registration granted to Desmond Gerald FitzGerald and Thomas John Jones, this 8th day of August, A.D. 1883.

AUGUSTUS LOFTUS.

---

REPORT.

Sir,

We do ourselves the honor to report, in reply to your blank cover of the 6th instant, No. 6,771, transmitting Mr. Desmond Gerald FitzGerald and Thomas John Jones' Petition for the registration of "Improvements in Secondary or Storage Batteries," that we are of opinion the prayer of the Petitioners may be granted in terms of Messrs. FitzGerald and Jones' specification and claim.

We have, &c.,

E. C. CRACKNELL.  
GOTHER K. MANN.

The Under Secretary of Justice.



A.D. 1883, 8th August. No. 1284.

**IMPROVEMENTS IN SECONDARY BATTERIES.**

LETTERS OF REGISTRATION to Desmond Gerald FitzGerald, Charles Henry Walker Biggs, and William Worby Beaumont, for Improvements in Secondary Batteries.

[Registered on the 10th day of August, 1883, in pursuance of the Act 16 Vic. No. 24.]

BY HIS EXCELLENCY THE RIGHT HONORABLE SIR AUGUSTUS WILLIAM FREDERICK SPENCER LOFTUS (commonly called LORD AUGUSTUS LOFTUS), Knight Grand Cross of the Most Honorable Order of the Bath, a Member of Her Majesty's Most Honorable Privy Council, Governor and Commander-in-Chief of the Colony of New South Wales and its Dependencies.

TO ALL TO WHOM THESE PRESENTS SHALL COME, greeting:

WHEREAS DESMOND GERALD FITZGERALD, of Brixton, in the County of Surrey, England, and CHARLES HENRY WALKER BIGGS and WILLIAM WORBY BEAUMONT, both of the Strand, in the County of Middlesex, England, have by their Petition humbly represented to me that they are the authors or designers of a certain invention or improvement in manufactures, that is to say, of an invention entitled "Improvements in Secondary Batteries," which is more particularly described in the specification and the sheet of drawings which are hereunto annexed; and that they, the said Petitioners, have deposited with the Honorable the Treasurer of the said Colony of New South Wales the sum of Twenty Pounds sterling, for defraying the expense of granting these Letters of Registration as required by the Act of Council, sixteenth Victoria, number twenty-four; and have humbly prayed that I would be pleased to grant Letters of Registration, whereby the exclusive enjoyment and advantage of the said invention or improvement might be secured to them for a period of fourteen years: And I, being willing to give encouragement to all inventions and improvements in the arts or manufactures which may be for the public good, and having received a report favourable to the prayer of the said Petition, from competent persons appointed by me to examine and consider the matters stated therein and to report thereon for my information, am pleased, with the advice of the Executive Council, and in exercise of the power and authority given to me by the said Act of Council, to grant, and do by these Letters of Registration grant unto the said Desmond Gerald FitzGerald, Charles Henry Walker Biggs, and William Worby Beaumont, their executors, administrators, and assigns, the exclusive enjoyment and advantage of the said invention or improvement for and during the term of fourteen years from the date hereof; to have, hold, and exercise unto the said Desmond Gerald FitzGerald, Charles Henry Walker Biggs, and William Worby Beaumont, their executors, administrators, and assigns, the exclusive enjoyment and advantage thereof for and during and unto the full end and term of fourteen years from the date of these presents next and immediately ensuing, and fully to be complete and ended: Provided always, that if the said Desmond Gerald FitzGerald, Charles Henry Walker Biggs, and William Worby Beaumont shall not, within three days after the granting of these Letters of Registration, register the same in the proper office in the Supreme Court, at Sydney, in the said Colony of New South Wales, then these Letters of Registration, and all advantages whatsoever hereby granted, shall cease and become void.

In witness whereof, I have hereunto set my sign manual, and have caused the present Letters of Registration to be sealed with the seal of the said Colony of New South Wales, at Government House, Sydney, in New South Wales, this eighth day of August, in the year of our Lord one thousand eight hundred and eighty-three.

[L.S.]

AUGUSTUS LOFTUS.

*Improvements in Secondary Batteries.*

SPECIFICATION of DESMOND GERALD FITZGERALD, of Brixton, in the County of Surrey, and CHARLES HENRY WALKER BIGGS, and WILLIAM WORBY BEAUMONT, both of the Strand, in the County of Middlesex, entitled "Improvements in Secondary Batteries."

THIS invention relates to the production of the plates or electrodes employed in secondary batteries. It is necessary that these plates should expose large surface to contact with the electrolyte.

One part of our invention consists in making these plates by drawing sheets of lead between two flat surfaces of wood or metal, one of which has a reciprocating motion of small range, and is provided with a number of fixed points, such as pin or needle points, disposed in such a manner as to finely perforate or puncture the sheet of lead, which is drawn at the necessary speed between the two surfaces, so that the perforations or punctures may be closely contiguous.

After perforation or puncturing, the plates are oxidised or chemically treated, so as to prevent metallic union when being mechanically manipulated, as herein further set forth. With this in view, we prefer to immerse the perforated plates in dilute sulphuric acid, contained in a vessel from which air may be withdrawn, the object of this being to fill the minute holes or punctures with a fluid, such as dilute sulphuric acid, capable of acting superficially upon the metal, so as to produce, for instance, a coating of lead sulphate within the perforations.

The lead sheet, or plate, so treated, may be at once employed to form electrodes, or the sheets may be folded by simple or return folds and then pressed, and may be at either or all stages re-perforated or re-punctured, and treated as before described. By this system of perforating and re-perforating or puncturing at each operation, treating the perforations or punctures as before described, we obtain a plate having great porosity.

In carrying this part of our invention into effect, we find that it is of importance that the aforesaid flat surface, which has a reciprocating motion of small range, and is provided with a number of needle points for finely perforating or puncturing the sheet of lead, should be of small area as compared with the area of the sheet of lead. We, therefore, puncture the sheets or plates of lead by means of a number of needle points, placed in a holder having a reciprocating motion somewhat like the needle-holder of a sewing machine, the sheets being gradually fed under the needle points by adjustable well-known mechanical means, such, for instance, as those employed in sewing machines, so that the distance between the punctures may be controlled to great minuteness. The punctures may thus be made so fine, and so close together, as to give the lead plate the character of true porosity.

In this way we have made porous plates, the needle-holder in some cases containing seventy-five needles in a circular tubular holder of about  $\frac{1}{4}$  inch in diameter, and the rate of feed of the plate being in some cases only about one-hundredth of an inch for each stroke of the needle-holder.

A machine and the needle or needle point holders for puncturing the plates in the manner herein described may be made as shown in the drawings hereunto attached, and which we will now describe.

In these drawings fig. 1 is a side elevation of the machine; and fig. 2, an end elevation; figs. 3, 4, and 5 are side view, sectional end view, and plan section of one form of needle-holder; and figs. 6 and 7 are vertical section and side elevation of another form of holder.

In fig. 1, *a* is the needle point holder, fixed by the set screw *b*, into the boss *c*, in the end of the spring arm *d*. This arm has a reciprocating movement imparted to it by the crank *e*, and rod *f*, attached by a slightly flexible piece at *g*, and driven by ordinary means, such as a strap running on the pulley *h*. The lead plate *i*, to be perforated or punctured, rests upon the plate *k*, to which it is fixed by the clamping screw *l*. The plate *k* has a radius arm *k'* attached to it, by which it is connected to the sliding feed piece *m* in the boss *n*; at the end of the sliding piece *m* there is a screw *m'*, which may move the piece *k*, *k'*, by means of the hand-nut *o*, thus effecting the feed of the plate *i* under the needle points in one direction. The plate *k* rests upon a sliding piece *p*, on the under side of which a rack is formed at *p'* into which rack *p'* a pinion *g* gears. This pinion receives motion through the medium of the ratchet wheel *r*, ratchet *s*, lever *t*, and rod *u*, a reciprocating motion being given to the rod *u*, and thereby to the ratchet *s*, by the crank *v*. The lever *t* may have a slot or holes, as shown, so as to adjust the amount of movement given to the ratchet wheel *r*, and thereby to the pinion *g* and rack at *p'*.

The feed of the lead plate or sheet to be punctured is thus effected in the opposite direction to that effected by the screw *m'*, and the slide piece *k*, *k'*. The feed movement effected by the ratchet *s* and pinion *g*, and other details connected therewith, by which the slide is moved in a direction transverse to that of the machine, causes the plate *k* with the lead plate or sheet to be carried also across the machine, but the connection of the plate *k* to the radius *k'* causes the plate *k*, and the lead plate *i*, to move in the arc of a circle, so that the lines of punctures are curved. We do not, necessarily, require curved lines of punctures, but this arrangement of transverse feed is convenient, though a straight line feed may, if preferred, be given to the plate *k* by the well-known mechanical means, which, however, would not be so simple for the feed in the direction of the length of the machine. The arm *w* is a spring finger-arm, similar to a presser-foot in a sewing machine, to keep the lead plate *i* from rising when the upward stroke of the needle-holder is made, and it may nearly touch the lead plate, or may press upon it with a pressure adjustable by the hand-screw *w'*.

The end of this arm has a hole *w''* to permit the needle points to reach the lead plate, this hole being of the necessary form to suit the arrangement of the needle points, whether held in a holder, as shown at figs. 6 and 7, which is the form also shown at *a*, fig. 1, or whether of the form shown at figs. 3, 4, and 5. The latter form of holder would usually be set, so that the line of the needle points would be at an angle with the direction of length of the machine, so as to make the punctures at points of intersection of parallel and angularly transverse lines as above described. This machine and these holders are only shown as some of the forms which may be used to effect the puncturing or perforating. The puncturing may be done on both sides of the lead plate.

Fig. 8 is a side view, and fig. 9 an end view of an electrode punctured in certain parts of the surface, leaving ribs for the sake of strength, but they may be punctured all over.

Another method, by which we obtain plates having large surface, consists in placing a quantity of lead granules or fragments into moulds or dies subjected to a temperature equal to, or near, the melting point



*Improvements in Secondary Batteries.*

point of lead, so that the granules or fragments may adhere by metallic union, but leave interstitial spaces, pressure being applied to the mass while in the heated condition. In order more effectually to preserve these interstitial spaces, especially when a considerable pressure, such as 100 to 200 pounds on the square inch, is used, we may mingle with the lead granules or fragments such other materials as will not only form permanent components of the electrodes, but such as will obviate the necessity for producing these materials on or in the electrodes by electrolysis by the process known as "forming." These materials may be an oxide or sulphate of lead. And, having made this mixture, we place it in moulds or dies subjected to a temperature equal to, or near, the melting point of lead, and we, by preference, simultaneously subject the heated mass to compression, so that the granules may adhere by metallic union, the interstitial spaces being partly or wholly filled with the oxide of lead or sulphate of lead. The plate or blocks so far produced may be heated as before described to prevent further metallic union, or, without this treatment, may, with the mould, be placed in a roller press, or hydraulic press, so as to complete the union of the metallic lead sufficiently to make the mass firmly coherent, and may thus be made into thin plates, and, if necessary, perforated and rerolled as before described.

Another way, by which we produce porous plates consists in inserting black-leaded open-meshed fabric, such as common net, in an electrolytic bath to receive a coating or deposit of lead. Or the fabric, instead of being coated with black lead, may be coated with a thin conducting layer of metallic sulphide or of a metal, by immersing, for instance, the fabric in a salt of copper or silver, and subsequently exposing the fabric to the action of sulphide of hydrogen or ammoniac sulphide; or, again, by immersing the fabric in a solution of salt of silver platinum, or gold, and subsequently exposing the fabric to the action of hydrogen gas, or other suitable reducing agent, at a sufficiently elevated temperature, but one considerably below that which would effect the charring of the fabric. The fabric, so treated, is subsequently placed in an electrolytic bath to receive, by electro-deposition, a coating of lead. A number of the sheets of lead-coated fabric thus obtained, are preferably superposed and subjected to the operation of rolling or pressing, after which they may be folded and rerolled or repressed. At each of these stages the surfaces may be oxidised as before described, but in this process of manufacture the chemical separation of the surfaces is not essential.

Another method by which we propose to make these plates is to weave a kind of close fabric of lead wire. A sheet so made, and, after being treated as before described to prevent metallic union in the interstitial spaces, may be folded and heavily pressed on itself one or more times, or rolled and then have the superposed edges united by dipping them into molten lead or burning. Plates so formed may then be treated, rerolled, and perforated, as hereinbefore described, and at a number of spots (say) 2 or 3 inches apart, the material of these sheets so made may be riveted with lead rivets, or melted together by a heated tool or bit like a flat-ended copper soldering tool, or by other equivalent suitable means, so as to give strength to the fabric.

According to the second part of our present invention, we deposit lead electrolytically, either within moulds or dies in which the material is intended to be compressed, or in other moulds of similar form, or we deposit in bulk so as to obtain a mass of finely divided crystalline lead, such mass constituting the material from which porous plates or cakes, flat or otherwise, may be obtained by compression. For example, we place horizontally, within a suitable mould, a plate of lead or other conductor disposed horizontally and constituting the cathode, or negative electrode, in a solution of acetate or other suitable salt of lead, and we support the anode, which is a plate of lead, in any convenient position in the same bath; this anode may be of any convenient form; it may thus, for instance, form an inner lining to the vertical side of the bath, containing the electrolytic solution. The several moulds and the anode and cathodes may be all placed in a bath of the solution, or the solution, or the materials for it, may be placed in each mould separately.

Preferably, we employ a battery consisting of such a number of these baths in series, so that the resistance of the battery is equal to the internal resistance of the machine which supplies the current.

Fig. 10 is a perspective view of three baths B, in each of which is placed a plate cathode C, forming the bottom of two moulds M, and covered with non-conducting varnish or other coating, except in the interior of the mould. A is the anode.

Fig. 11 is a vertical section through a series of three baths B, in each of which are provided three cathode plates C, for mould M to rest on.

When a current from a dynamo-machine or other generator is passed through the solution by means of the above-mentioned electrodes, lead is dissolved at the anode A, and thrown down at the cathode C, that is within the moulds M, and, if the current be of sufficient strength, the lead is deposited as a finely divided crystalline mass, not adherent to the cathode or interior of the mould M.

The cathode plate, with mould or moulds, is then, with as little disturbance of the mass as possible, removed from the electrolytic bath B, and the crystalline mass in its mould having been removed from the cathode plate C and placed on a strong metallic plate, such as P fig. 11<sup>A</sup>, is put in a press and subjected to a sufficient pressure to convert it into a firmly coherent, but porous cake or plate. This may be done either immediately on its being taken from the electrolytic bath, or, by preference, after a process of partial oxidation by air or otherwise; but if the electrolytic bath contains free acid, the aforesaid special partial oxidation before the compression is not indispensable, as the said free acid adhering to the lead particles in the mould, will sufficiently prevent complete metallic union of the particles. The pressure employed should be about from 400 to 1000 pounds per square inch, or more, according to the degree of cohesion desired. The moulds M, figs. 10 and 11, may be of wood or of metal coated with a non-conducting material or varnish. When made of metal, the moulds may be used as the pressing die D in fig. 11<sup>A</sup>, which also shows the upper die D' and the tang T, which latter will be referred to later on.

Or, we deposit the crystalline mass of lead in bulk upon a large cathode in the bottom of an electrolytic bath, the deposited material being afterwards washed and divided into weighed masses, from which the porous plates are made by compression as before.

We do not confine ourselves to acetate of lead for the production of our compressed porous lead plates, but may employ any known suitable salt of lead for obtaining spongy metallic lead by electrolysis.

We may also make our elements, or electrodes, of very finely granulated or pulverised lead (obtained by means, which for distinction from the chemical and electro-chemical methods, we will call  
mechanical



*Improvements in Secondary Batteries.*

mechanical means), and this finely granulated or pulverised lead, after partial oxidation, in air or otherwise, we compress into cakes or plates with the necessary pressure, say in a mould or die in the manner before described, or just as powdery clay is pressed into hard cakes to form tiles. One way of obtaining the lead fragments is by cutting up lead foil, for instance, by a machine similar to a chaff-cutter or tobacco-cutting machine.

In some cases we compress a tang with fangs made of suitable metal, as lead, into the thickness, and entering at one of the edges or corners of the compressed porous lead cake or plate, the part projecting therefrom acting as a contact-piece. Or we may compress into the body of the cake or plate a thin sheet or skeleton frame of suitable metal, such as lead, the said sheet having a number of large holes made in it; a small piece of this skeleton frame projects from the porous plate or cake to act as a contact-piece. The insertion of either the fanged tang or the skeleton sheet of metal we effect by placing them into the mould in which the material of the plate is deposited when the process of deposition is about half completed, and a suitable aperture or space is made in the mould to allow of its projection from the general contour of the cake, or plate, as shown in fig. 11<sup>a</sup> already referred to. By the ramification of the tang throughout the interior of the porous electrode, we diminish the internal resistance and form a firm connection thereto.

Fig. 12 shows a form of tang T embedded edgewise in a porous electrode and made of flat wire or ribbon lead; fig. 13 is a side view of the electrode; fig. 14 shows an electrode in which the flat wire tang is placed flat in the electrode.

Figs. 15 to 19<sup>a</sup> show various forms of tangs made of round, flat, or other wire, and embedded in electrodes.

Fig. 20 shows a thin skeleton frame tang, made by forming large holes in thin sheet-lead; fig. 21 shows a flat tang cut from a thin sheet of lead and having fangs or branches embedded in the electrode.

And, having thus described and ascertained the nature of this invention, and the manner in which the same is, or may be, carried into effect, we declare that we claim,—

Firstly—The construction, or manufacture of porous electrodes for secondary batteries by minutely puncturing one, or both, surfaces of sheets or plates of lead, substantially as hereinbefore described.

Secondly—The construction, or manufacture, of porous electrodes for secondary batteries by the combined processes of minutely puncturing both surfaces of lead sheets or plates; then treating the plates by immersion in dilute sulphuric acid in a vessel from which air may be withdrawn so as to produce a deposit of lead sulphate thereon; then rolling the plates so as to extend their surface by reduction of thickness, and finally repuncturing or re-perforating the plates, substantially as hereinbefore described.

Thirdly—The construction of porous electrodes for secondary batteries by the electro-deposition of lead on a fine net fabric, so as to obtain a lead fabric, which is, preferably, folded in as many folds as may be desirable to make up any required thickness, and then pressed, substantially as hereinbefore described.

Fourthly—The construction of porous electrodes by the application of heat and pressure to lead granules with, or without, oxide or sulphate of lead in suitable moulds, substantially as described.

Fifthly—The construction of porous electrodes for secondary batteries from fabrics of woven lead wire, chemically treated, folded, and pressed, substantially as herein described.

Sixthly—The construction of porous lead electrodes for secondary batteries by the combined process of electro-depositing lead in a loosely coherent or crystalline form, partially oxidising the same, or chemically acting thereon with an acid, such as sulphuric acid, and then compressing the mass into cakes, plates, or any other suitable form, substantially as and for the purpose set forth.

Seventhly—The mode herein described of obtaining lead in a loosely coherent or crystalline form by electro-deposition in the interior of a mould the bottom of which constitutes the cathode in an aqueous solution of a salt of lead, containing also a lead anode, substantially as and for the purpose set forth.

Eighthly—The construction of porous lead electrodes, with ramifying or otherwise distributed tangs, embedded in their mass and fixed therein by the pressure under which the mass is compressed into a firmly coherent form, substantially as and for the purpose set forth.

In witness whereof we, the said Desmond Gerald FitzGerald, Charles Henry Walker Biggs, and William Worby Beaumont, have hereunto set our hands and seals, this 4th day of May, 1883.

DESMOND G. FITZGERALD.

C. H. W. BIGGS.

W. WORBY BEAUMONT.

This is the specification referred to in the annexed Letters of Registration granted to Desmond Gerald FitzGerald, Charles Henry Walker Biggs, and William Worby Beaumont, this eighth day of August, A.D. one thousand eight hundred and eighty-three.

AUGUSTUS LOFTUS.

### REPORT.

Sir,

We do ourselves the honor to report, in reply to your blank cover of the 15th instant, No. 7,389, that we are of opinion the Petition of D. Gerald FitzGerald, C. H. W. Biggs, and W. W. Beaumont, for the registration of "Improvements in Secondary Batteries," may be granted in terms of their specification, drawings, and claim.

We have, &c.,

E. C. CRACKNELL.

GOTHER K. MANN.

The Under Secretary of Justice.

Fig. 10

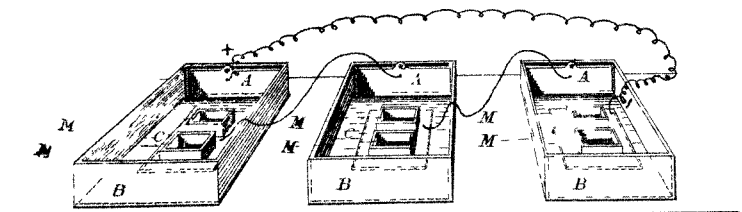


Fig. 11

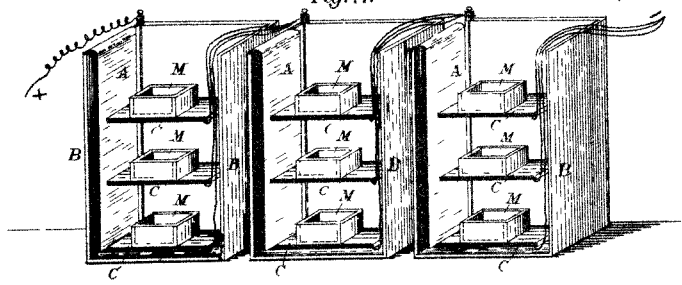


Fig. 12

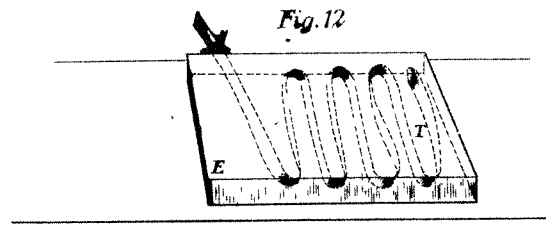


Fig. 11<sup>a</sup>

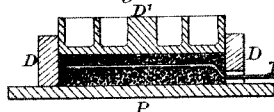


Fig. 14



Fig. 13

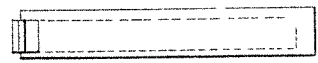


Fig. 15

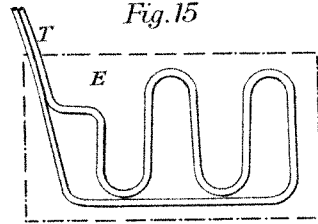


Fig. 16

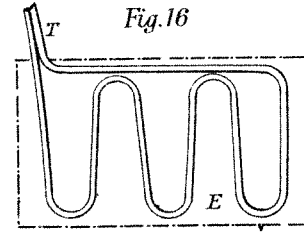


Fig. 17

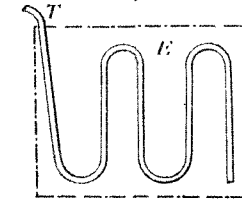


Fig. 19

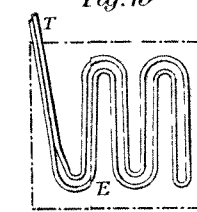


Fig. 19<sup>a</sup>

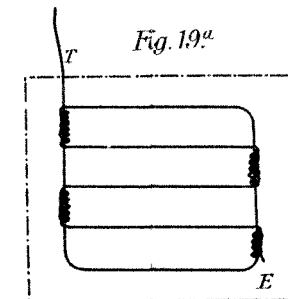


Fig. 18

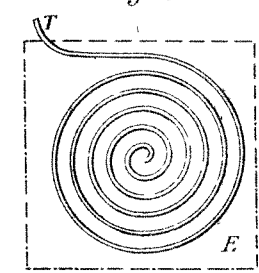


Fig. 20

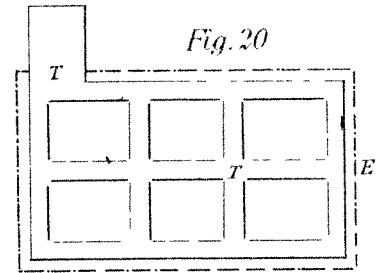


Fig. 21

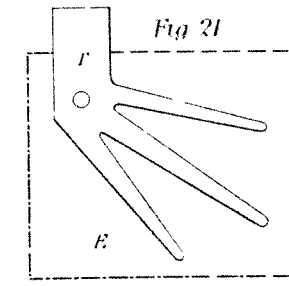


Fig. 1

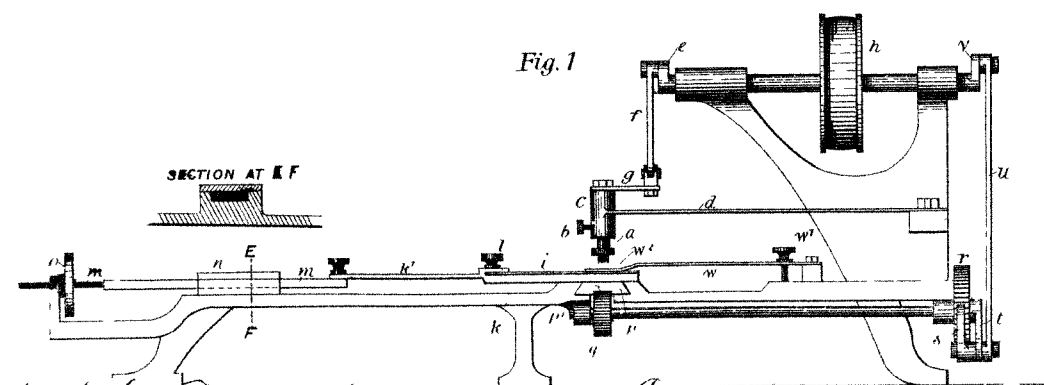


Fig. 2

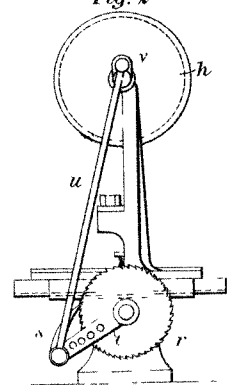


Fig. 3

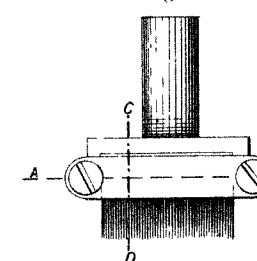


Fig. 4

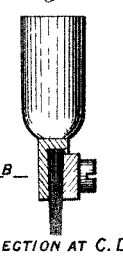


Fig. 6



Fig. 7



Fig. 8

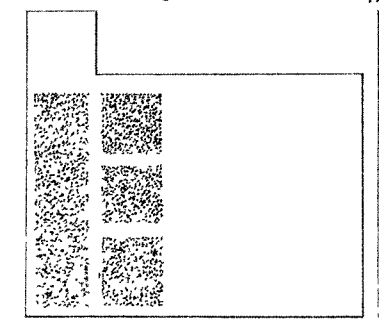


Fig. 9



SECTION AT C. D.

SECTION AT A. B.

This is the Sheet of Drawings referred to in the annexed Letters of Registration granted to Desmond Gerald Fitz-Gerald, Charles Walker Biggs and William Henry Beaumont, this eighth day of August, A.D. 1883.  
Augustus Loftus.



A.D. 1883, 8th August. No. 1285.

**IMPROVEMENTS IN AND RELATING TO REFRIGERATING MACHINES AND TO  
THE MANUFACTURE OF ICE.**

**LETTERS OF REGISTRATION** to Edmund Taylor and William Humble, for  
Improvements in and relating to Refrigerating Machines and to the Manufac-  
ture of Ice.

[Registered on the 10th day of August, 1883, in pursuance of the Act 16 Vic. No. 24.]

BY HIS EXCELLENCY THE RIGHT HONORABLE SIR AUGUSTUS WILLIAM FREDERICK SPENCER LOFTUS  
(commonly called LORD AUGUSTUS LOFTUS), Knight Grand Cross of the Most Honorable Order of  
the Bath, a Member of Her Majesty's Most Honorable Privy Council, Governor and Commander-in-  
Chief of the Colony of New South Wales and its Dependencies.

TO ALL TO WHOM THESE PRESENTS SHALL COME, greeting :

WHEREAS EDMUND TAYLOR, of Pevensey Crescent, Geelong, in the Colony of Victoria, technical  
chemist, and WILLIAM HUMBLE, of the Vulcan Foundry, Little Malop-street, Geelong aforesaid, founder,  
have by their Petition humbly represented to me that they are the assignees of the said Edmund Taylor,  
who is the author or designer of a certain invention or improvement in manufactures, that is to say, of an  
invention entitled "Improvements in and relating to Refrigerating Machines and to the Manufacture of  
Ice," which is more particularly described in the specification and the sheet of drawings which are  
hereunto annexed ; and that they, the said Petitioners, have deposited with the Honorable the Treasurer  
of the said Colony of New South Wales the sum of Twenty Pounds sterling, for defraying the expense of  
granting these Letters of Registration, as required by the Act of Council, sixteenth Victoria, number  
twenty-four ; and have humbly prayed that I would be pleased to grant Letters of Registration, whereby  
the exclusive enjoyment and advantage of the said invention or improvement might be secured to them  
for a period of fourteen years : And I, being willing to give encouragement to all inventions and improve-  
ments in the arts or manufactures which may be for the public good, and having received a report favour-  
able to the prayer of the said Petition, from competent persons appointed by me to examine and consider  
the matters stated therein and to report thereon for my information, am pleased, with the advice of the  
Executive Council, and in exercise of the power and authority given to me by the said Act of Council, to  
grant, and do by these Letters of Registration grant unto the said Edmund Taylor and William Humble,  
their executors, administrators, and assigns, the exclusive enjoyment and advantage of the said invention  
or improvement, for and during the term of fourteen years from the date hereof ; to have, hold, and  
exercise unto the said Edmund Taylor and William Humble, their executors, administrators, and assigns,  
the exclusive enjoyment and advantage thereof, for and during and unto the full end and term of fourteen  
years from the date of these presents next and immediately ensuing, and fully to be complete and  
ended : Provided always, that if the said Edmund Taylor and William Humble shall not within three days  
after the granting of these Letters of Registration, register the same in the proper office in the Supreme  
Court, at Sydney, in the said Colony of New South Wales, then these Letters of Registration, and all  
advantages whatsoever hereby granted, shall cease and become void.

In witness whereof, I have hereunto set my sign manual, and have caused the present Letters of  
Registration to be sealed with the seal of the said Colony of New South Wales, at Govern-  
ment House, Sydney, in New South Wales, this eighth day of August, in the year of our  
Lord one thousand eight hundred and eighty-three.

[L.S.]

AUGUSTUS LOFTUS.

*Improvements in and relating to Refrigerating Machines and Manufacture of Ice.*

SPECIFICATION of EDMUND TAYLOR, of Pevensey Crescent, Geelong, in the Colony of Victoria, technical chemist, and WILLIAM HUMBLE, of the Vulcan Foundry, Little Malop-street, Geelong aforesaid, founder (the assignees of the said Edmund Taylor), for an invention entitled "Improvements in and relating to Refrigerating Machines and to the Manufacture of Ice."

THIS invention consists of three parts, the first relating to refrigerating machines, the second to the manufacture of ice, and the third to a novel method of using salt-water ice for cooling chambers.

The first part is an improvement on an invention entitled "Improvements in and connected with portable refrigerators and in refrigerating chambers," for which we have obtained New South Wales Letters of Registration, dated the twenty-sixth day of April, one thousand eight hundred and eighty-two. In the specification of that invention we have described one vessel as being used alternately as a boiler and as an absorber. Its action therefore as a cold producer is intermittent. Now, our present improvements thereon have been designed for the purpose of making its action as a cold producer as nearly as possible continuous, and consist in providing two such vessels, each of which acts in turn as a boiler and as an absorber, by which means we are enabled to approximate very closely to the continuous action; and secondly, in providing an auxiliary to such two vessels by which we are enabled to approximate still more closely to the continuous action, and at the same time to increase the absorbing power of the absorber.

The second part of this invention consists in the use of ice made from salted water as a refrigerating agent. By means of artificial ice made from water which is artificially salted, we can produce and maintain a uniformly lower temperature in refrigerating chambers than is possible with fresh-water ice. This lower temperature is very beneficial in the case of refrigerating railway cars, where it is exceedingly desirable to have a uniform temperature at or below freezing point, but which temperature cannot be maintained by fresh-water ice.

The third part of this invention consists in the use of removable moulds filled with salt-water ice as an agent for cooling chambers instead of bare blocks of ice. When the latter are used the ice is made in moulds, then the surface thawed, and the ice taken out. This ice is then placed in boxes within the chambers to be cooled, and there it gradually thaws. The ice-moulds have then to be refilled before freezing. Now, by our method the ice-moulds filled with ice are removed bodily into the ice-boxes, and when their contents are thawed they are simply lifted out and their contents refrozen, and so on, as often as needed.

Referring to our drawings, figure 1 shows side elevation partly in section of an apparatus constructed according to this invention; figure 2, plan thereof also partly in section; figure 3, end view; figure 4, side elevation of a modified form of part of our apparatus as hereinbefore explained; figure 4<sup>a</sup>, side elevation of same showing the auxiliary chamber; figure 5, side sectional elevation of a railway car, also constructed according to this invention; and figure 6, horizontal section thereof; figure 7, shows an ice-mould; and figure 8, an ice-box illustrating how these moulds may be placed therein.

In figures 1, 2, and 3, A and B are the vessels which act alternately as a boiler and an absorber, each being connected by pipes and taps with the condenser C, and with the freezing tank D. Vessel A has a fire-pot surrounding the lower part of it, marked A<sup>1</sup>, which is suspended by chains A<sup>2</sup> from suitable framing, A<sup>3</sup>, and is provided with a flue, A<sup>4</sup>. Vessel B has a cold-water vessel, B<sup>1</sup>, surrounding its lower part, such vessel suspended by chains, B<sup>2</sup>, from suitable framing, A<sup>3</sup>, and provided with overflow, B<sup>3</sup>. Vessels A and B are each supported by straps, A<sup>5</sup> and B<sup>5</sup> respectively, fixed to them, and resting on and attached to frame A<sup>3</sup>. Condenser C is also surrounded by a cold-water vessel, C<sup>1</sup>; C<sup>2</sup> are tubes through which the water first passes, and thence out into vessel C<sup>1</sup>, overflowing through pipe C<sup>3</sup>; A<sup>5</sup> is a pipe connecting vessel A with condenser C, and is enclosed in a larger pipe, A\*, through which flows a current of water supplied by pipe A<sup>6</sup>, through branch pipe A\*\*, and discharging through waste pipe A\*\*\*; A<sup>6</sup> is a pipe connecting vessel A to the cold-water supply, and A<sup>7</sup> is a pipe connecting said vessel to the freezing tank D.

B<sup>4</sup> is a pipe connecting vessel B to condenser C, and is enclosed by pipe B\*, through which flows a current of cold water admitted through pipe B\*\*, and discharging through waste pipe B\*\*\*; B<sup>5</sup> is a branch pipe leading to pipe A<sup>5</sup>, so as to connect vessel B to the cold-water supply, and B<sup>7</sup> is a pipe leading to A<sup>7</sup>, so as to connect vessel B with the freezing tank D; E, F, G, H, I, J, K, L are taps; D<sup>1</sup> are removable ice-moulds; the tank D is packed between its inner and outer casing with some bad conductor of heat, such as sawdust; M is the gauge-glass, with mounting, by which means the height of ammonia in condenser is ascertained.

The mode of operation is as follows: Vessels A and B are first charged with an equal quantity of ammonia and a fire lighted in the fire-pot, taps G, H, J, and K being open and the others shut, and the freezing tank D very nearly filled with a strong solution of chloride of calcium. The heat gradually drives the ammonia through pipe A<sup>5</sup> into the condenser. Here it condenses, and the tap L is gradually opened to allow the liquid ammonia to pass into the worm D<sup>2</sup>, where it gradually becomes revaporized, freezing the contents of the ice-moulds D<sup>1</sup> in the process, and finally returning by pipe A<sup>7</sup> into branch pipe B<sup>7</sup>, through tap G, to the vessel B. When the ammonia is nearly all out of A the operation is reversed, taps E, F, I, and K being opened and the rest closed; the fire-pot A<sup>1</sup>, and cold-water vessel B<sup>1</sup>, changing places, so as to make B the boiler for the time being, and A the absorber. As a practical illustration of the quantities of ammonia used, and the method of working, we may state, that with A and B five feet high we first charge each of them with three feet of ammonia, then drive over one foot from A into B, then reverse operations, driving two feet of ammonia over into A, and then two feet back again to B, and so on. The process of reversing the action of the apparatus may be repeated *ad infinitum*, or until the parts wear out, or the ammonia leaks out. But instead of D being a freezing tank for the making of ice it may simply be a refrigerating chamber, the temperature of which is reduced by the passage of the ammonia, and its conversion from a liquid into a gas or vapour.

Instead of using direct heat we may use steam, and instead of heating and cooling the vessels A and B by means of outer vessels, A<sup>1</sup> and B<sup>1</sup>, we may do so by a coil or worm inside. This modification is illustrated in figure 4, in which P is the cold-water pipe, and Q the steam pipe, and R the coils. Pipes A<sup>5</sup>, A<sup>7</sup>, B<sup>4</sup>, and B<sup>7</sup> are for identical purposes with those similarly marked in figures 1 and 2.

Figure

*Improvements in and relating to Refrigerating Machines and Manufacture of Ice.*

Figure 4<sup>a</sup> shows our improved apparatus with the auxiliary cooler introduced, consisting of the vessel or receiver T, surrounded by the cold-water vessel T<sup>1</sup>; T<sup>2</sup> and T<sup>3</sup> are inlet pipes from vessels A and B respectively to the vessel or receiver T; and T<sup>4</sup> and T<sup>5</sup> are outlet pipes from said vessel or receiver to the said vessels A and B. The remaining letters refer to parts similarly marked in figure 4.

The mode of operation when our auxiliary cooler is introduced is as follows: The vessel A having just been used as a boiler, and the necessary amount of ammonia driven out of it, is now to be used as an absorber. We accordingly open cock on pipe T<sup>2</sup>, when the pressure in said vessel A will force the remaining liquor—a weak solution—up said pipe into the cooler, where it remains until the vessel A is cooled. Tap on pipe T<sup>2</sup> is then closed, and that upon pipe T<sup>4</sup> opened, when the liquor will flow back into vessel A. The inlet and outlet pipes, T<sup>3</sup> and T<sup>5</sup>, to boiler B, during this time are closed. As the cooled but weak liquor returns to the vessel A, it increases the vacuum therein, and so increases its power as an absorber.

In figures 7 and 8 we show how the third part of our invention is to be carried out. U is a metal mould with screw plug U<sup>1</sup> for filling it, and handles, U<sup>2</sup>, for lifting it. Salt ice is formed in these moulds, which are placed in a box in the chamber to be cooled, such as box S, in figure 6. When its contained ice has thawed it is lifted out and replaced in the freezing chamber to be refrozen.

Having thus described the nature of our invention, and the manner of performing same, we would have it understood that we do not claim the use of ammonia for refrigerating purposes, nor to the use of a vessel which is alternately a boiler and an absorber in refrigerating machines, but what we believe to be new and useful, and therefore claim as our improvements in and relating to refrigerating machines, and to the manufacture of ice, is,—

First—The combination of two vessels which act alternately as boilers and absorbers with a condenser and a freezing tank, or refrigerating tank, so as to enable the process of freezing or refrigerating to be carried on in an approximate continuous manner, substantially as herein described and explained with reference to figures 1 to 4.

Second—The combination of the auxiliary cooler T<sup>1</sup> with the two vessels which act alternately as boilers and absorbers, substantially as herein described and explained with reference to figure 4<sup>a</sup>.

Third—The use of salt-water ice as a refrigerating agent in travelling chambers, substantially as herein described and explained.

Fourth—The use of removable moulds filled with salt-water ice as an agent for cooling chambers, instead of bare blocks of ice, substantially as herein described and explained.

In witness whereof, we, the said Edmund Taylor and William Humble, have hereunto set our hands and seals this twenty-fifth day of May, one thousand eight hundred and eighty-three.

Witness—

W. H. CARR, Geelong, bookkeeper.

EDMUND TAYLOR.

W. HUMBLE.

This is the specification referred to in the annexed Letters of Registration granted to Edmund Taylor and William Humble, this eighth day of August, A.D. 1883.

AUGUSTUS LOFTUS.

---

REPORT.

Sir,

We do ourselves the honor to report, in reply to your blank cover of the 6th instant, No. 6,769, that we are of opinion Letters of Registration may be granted in favour of Messrs. Edmund Taylor and William Humble, for an invention entitled "Improvements in and relating to Refrigerating Machines, and to the Manufacture of Ice," in accordance with the Petitioners' specification, drawing, and claim.

We have, &c.,

E. C. CRACKNELL.  
GOTHER K. MANN.

The Under Secretary of Justice.

---

[Drawings—one sheet.]

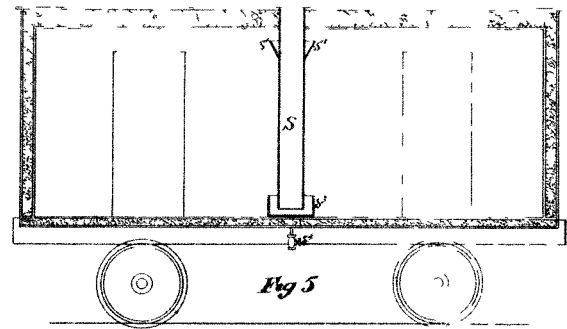


Fig 5

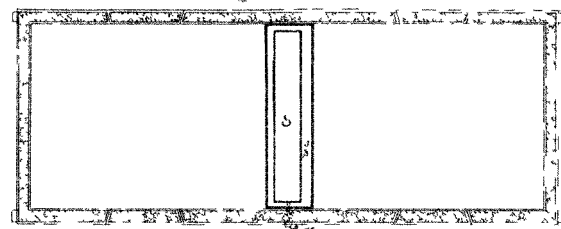


Fig 6

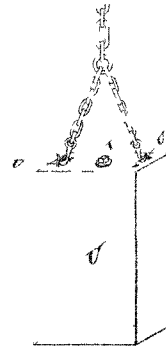


Fig 7

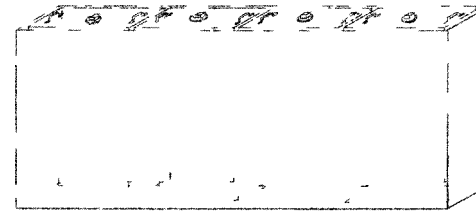


Fig 8.

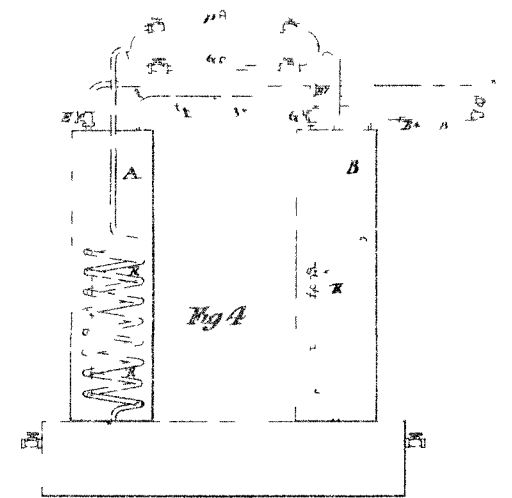


Fig 4

**TAYLOR & HUMBLE'S PATENT**

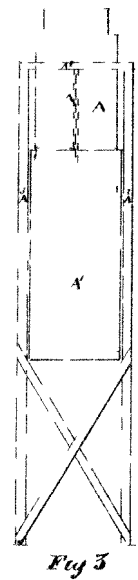


Fig 3

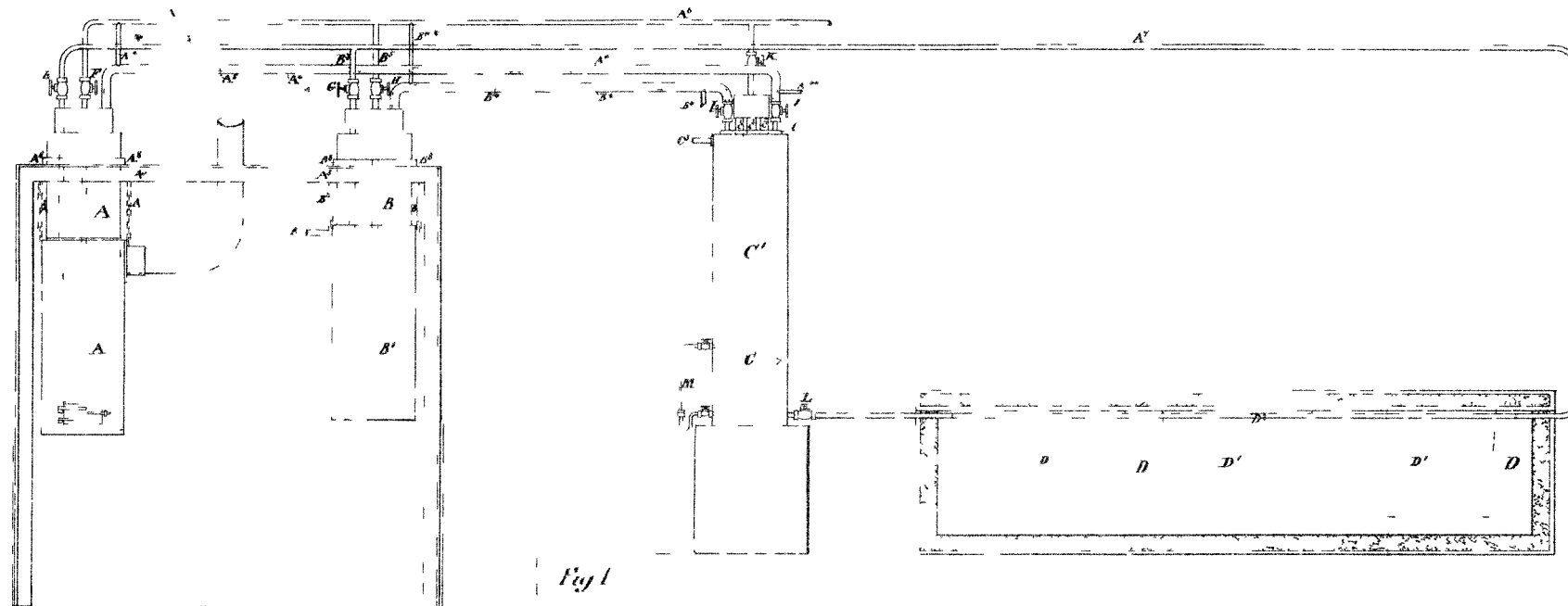


Fig 1

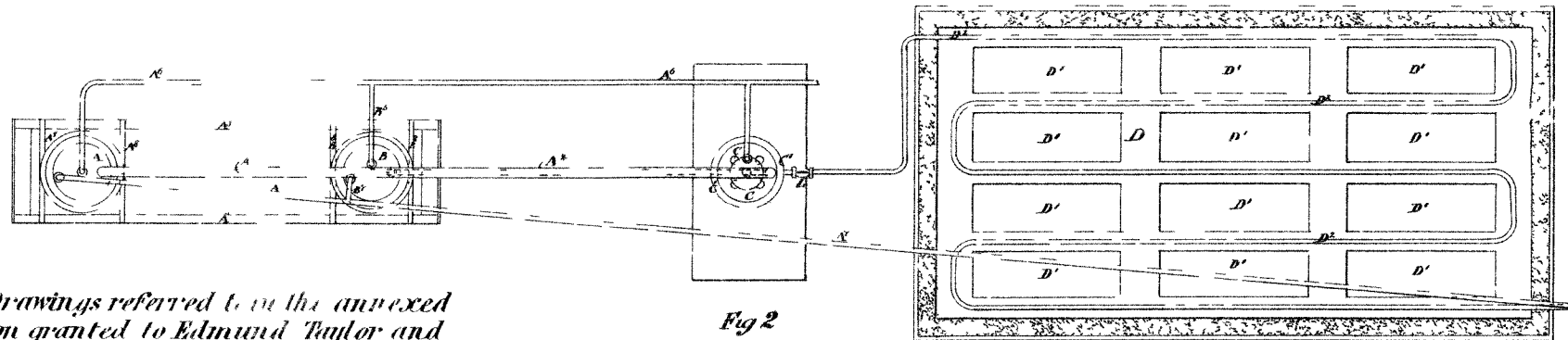


Fig 2

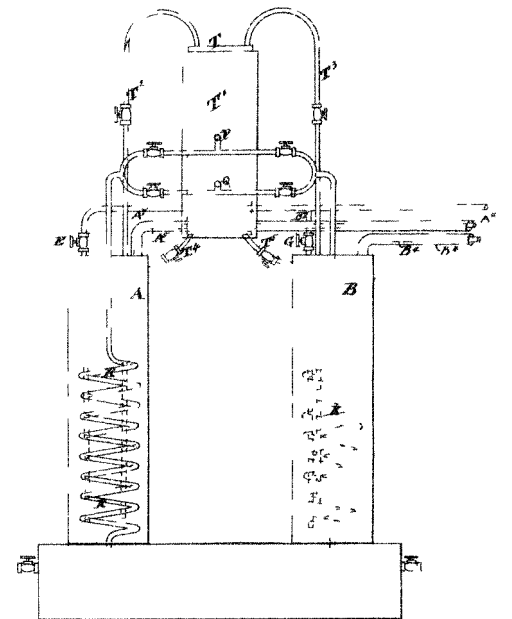


Fig 4<sup>a</sup>

*This is the Sheet of Drawings referred to in the annexed Letters of Registration granted to Edmund Taylor and William Humble this eighth day of August A.D. 1883.  
Augustus Loftus.*

PRINTED AND SOLD BY THE PATENT OFFICE, 25, SOUTH WHARF, LONDON.



A.D. 1883, 8th August. No. 1286.

**IMPROVEMENTS IN EXTRACTING GOLD AND SILVER FROM THEIR ORES, AND IN APPARATUS FOR THE PURPOSE.**

**LETTERS OF REGISTRATION to Richard Barker for Improvements in extracting Gold and Silver from their Ores, and in Apparatus for the purpose.**

[Registered on the 10th day of August, 1833, in pursuance of the Act 16 Vic. No. 24.]

BY HIS EXCELLENCY THE RIGHT HONORABLE SIR AUGUSTUS WILLIAM FREDERICK SPENCER LOFTUS (commonly called LORD AUGUSTUS LOFTUS), Knight Grand Cross of the Most Honorable Order of the Bath, a Member of Her Majesty's Most Honorable Privy Council, Governor and Commander-in-Chief of the Colony of New South Wales and its Dependencies.

TO ALL TO WHOM THESE PRESENTS SHALL COME, greeting:

WHEREAS RICHARD BARKER, of London, in England, mining engineer, hath by his Petition humbly represented to me that he is the author or designer of a certain invention or improvement in manufactures, that is to say, of an invention entitled "Improvements in extracting Gold and Silver from their Ores, and in Apparatus for the purpose," which is more particularly described in the specification and sheet of drawings which are hereunto annexed; and that he, the said Petitioner, hath deposited with the Honorable the Treasurer of the said Colony of New South Wales the sum of Twenty Pounds sterling for defraying the expense of granting these Letters of Registration, as required by the Act of Council, sixteenth Victoria, number twenty-four, and hath humbly prayed that I would be pleased to grant Letters of Registration whereby the exclusive enjoyment and advantage of the said invention or improvement might be secured to him for a period of fourteen years: And I, being willing to give encouragement to all inventions and improvements in the arts or manufactures which may be for the public good, and having received a report favourable to the prayer of the said Petition from competent persons appointed by me to examine and consider the matters stated therein and to report thereon for my information, am pleased, with the advice of the Executive Council, and in exercise of the power and authority given to me by the said Act of Council, to grant, and do by these Letters of Registration grant unto the said Richard Barker, his executors, administrators, and assigns, the exclusive enjoyment and advantage of the said invention or improvement, for and during the term of fourteen years from the date hereof; to have, hold, and exercise unto the said Richard Barker, his executors, administrators, and assigns, the exclusive enjoyment and advantage thereof for and during and unto the full end and term of fourteen years from the date of these presents next and immediately ensuing, and fully to be complete and ended: Provided always, that if the said Richard Barker shall not, within three days after the granting of these Letters of Registration, register the same in the proper office in the Supreme Court, at Sydney, in the said Colony of New South Wales, then these Letters of Registration, and all advantages whatsoever hereby granted, shall cease and become void.

In witness whereof, I have hereunto set my sign manual, and have caused the present Letters of Registration to be sealed with the seal of the said Colony of New South Wales, at Government House, Sydney, in New South Wales, this eighth day of August, in the year of our Lord one thousand eight hundred and eighty-three.

[L.S.]

AUGUSTUS LOFTUS.

---

*Apparatus for Extracting Gold and Silver from their Ores, &c.*

---

SPECIFICATION of RICHARD BARKER, of London, in England, mining engineer, for an invention entitled "Improvements in extracting Gold and Silver from their Ores, and in Apparatus for the purpose."

MY invention relates to improvements in extracting gold and silver from their ores, by the combined action of electricity, mercury, and water, applied in the manner and by means of apparatus as hereinafter described.

For the purpose of my invention I provide a table in which I arrange a number of riffles, vats, troughs, or other suitable vessels, insulated or not, and made of iron, wood, porcelain, ebonite, gutta-percha, and its products, earthenware (glazed or unglazed), or any other suitable material. A current of electricity is then applied to the water by one or more suitable cathodes and anodes placed therein. The electricity is allowed to flow from one pole to the other, thereby producing an agitation on the surface of the mercury, and causing it to absorb gold and silver.

I cause, by any convenient means, a stream of water to pass over or through the table, vat, trough, or other vessel containing the ore to be operated upon; one object being to wash away the waste ore, and the other to furnish a continuous supply of hydrogen and oxygen to the ore.

To assist the agitation on the surface of the mercury, I provide one or more stirrers or agitators.

And in order that my invention may be readily understood and carried into effect by any competent person experienced in the art or process to which it relates, I proceed to describe the same, with reference to the accompanying drawings.

Figure 1 is a plan of a riffle, vat, or trough, to which my improvements are applied; the stirrers, however, being removed for sake of clearness.

Figure 2 is a cross-section of a riffle, vat, or trough, showing the portion of the main cathode and the stirrer; the branch cathode being shown in the water, but above the mercury.

Figure 3 is a cross-section of a riffle, vat, or trough, showing the position of the main anode and stirrer; the branch anodes being shown in the water above the mercury.

R is the riffle, vat, or trough, along one side of which the main anode A is laid. From this anode A, branch anodes, A' A', pass into the water and across the riffle. On the opposite side of the riffle is laid the main cathode C, from which branch cathodes C' C', extend into the water and across the riffle in the opposite direction, and sufficiently far away from the branch anodes so as not to touch one another. S is a stirrer to assist agitation on the surface of the mercury.

H is the terminal of the branch anodes, and H' the terminal of the branch cathodes.

$x$  is the wire from the battery, or other source of electricity, and  $y$  is the return wire.

Having now described the nature of my invention, and in what manner the same may be performed, I declare that I claim:—

In apparatus for extracting gold and silver from their ores by the combined action of electricity, mercury, and water, the branch cathodes and anodes arranged to extend across the riffle, vat, or trough, and to lie in the water, and above the mercury, substantially as described and shown, and for the purpose set forth.

In witness whereof, I, the said Richard Barker, have hereunto set my hand and seal, this nineteenth day of April, in the year 1883.

RICHARD BARKER.

This is the specification referred to in the annexed Letters of Registration granted to Richard Barker, this eighth day of August, A.D. 1883.

AUGUSTUS LOFTUS.

---

REPORT.

---

Sir,

The Petition of Mr. Richard Barker for Letters of Registration for an invention entitled "Improvements in extracting Gold and Silver from their Ores, and in Apparatus for the purpose," having been referred to us, we have examined the drawings, specification, and claim accompanying the same, and have now the honor to report that we see no objection to the issue of Letters of Registration as prayed for.

We have, &c.,

A. LEIBIUS.

CHAS. WATT.

The Under Secretary of Justice.



Fig. 1.

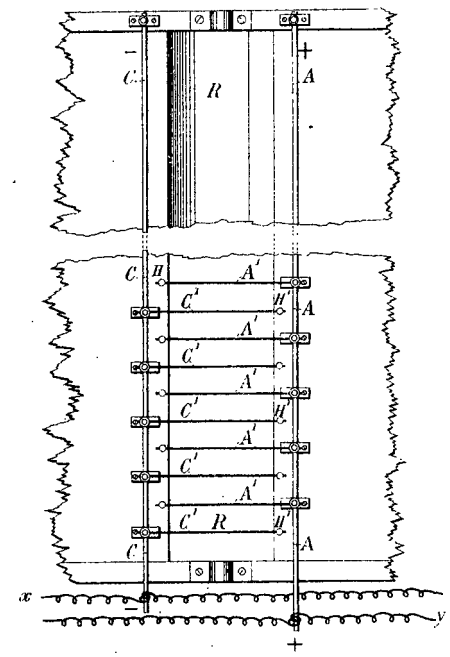


Fig. 2.

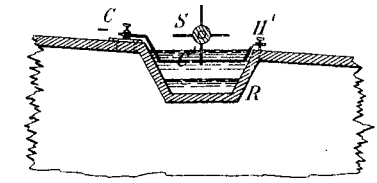
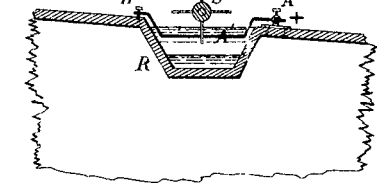
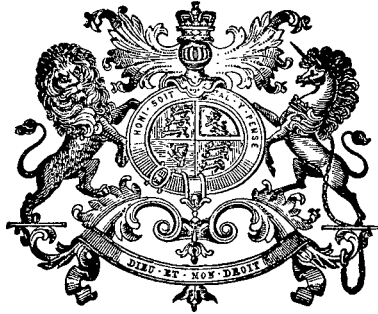


Fig. 3.



*This is the Sheet of Drawings referred to in the annexed  
 Letters of Registration granted to Richard Barker, this  
 eighth day of August A.D. 1883.*  
*Augustus Loftus.*



A.D. 1883, 8th August. No. 1287.

**IMPROVEMENTS IN THE EXTRACTION OF SACCHARINE MATTER FROM  
VEGETABLE SUBSTANCES.**

LETTERS OF REGISTRATION to George Fry, Carl Daniel Ekman, and William Bancroft Espeut, for an Invention entitled "Improvements in the Extraction of Saccharine matter from Vegetable substances."

[Registered on the 10th day of August, 1883, in pursuance of the Act 16 Vic. No. 24.]

BY HIS EXCELLENCY THE RIGHT HONORABLE SIR AUGUSTUS WILLIAM FREDERICK SPENCER LOFTUS (commonly called LORD AUGUSTUS LOFTUS), Knight Grand Cross of the Most Honorable Order of the Bath, a Member of Her Majesty's Most Honorable Privy Council, Governor and Commander-in-Chief of the Colony of New South Wales and its Dependencies.

TO ALL TO WHOM THESE PRESENTS SHALL COME, greeting:

WHEREAS GEORGE FRY, of 57½ Old Broad-street, in the City of London, England, merchant, CARL DANIEL EKMAN, of Bergirk, in Sweden, chemist, and WILLIAM BANCROFT ESPEUT, of the Island of Jamaica, have by their Petition humbly represented to me that they are the authors or designers of a certain invention or improvement in manufactures, that is to say, of an invention entitled "Improvements in the Extraction of Saccharine matter from Vegetable substances," which is more particularly described in the specification which is hereunto annexed; and that they, the said Petitioners, have deposited with the Honorable the Treasurer of the said Colony of New South Wales the sum of Twenty Pounds sterling, for defraying the expense of granting these Letters of Registration, as required by the Act of Council, sixteenth Victoria, number twenty-four, and have humbly prayed that I would be pleased to grant Letters of Registration, whereby the exclusive enjoyment and advantage of the said invention or improvement might be secured to them for a period of fourteen years: And I, being willing to give encouragement to all inventions and improvements in the arts or manufactures which may be for the public good, and having received a report favourable to the prayer of the said Petition, from competent persons appointed by me to examine and consider the matters stated therein and to report thereon for my information, am pleased, with the advice of the Executive Council, and in exercise of the power and authority given to me by the said Act of Council, to grant, and do by these Letters of Registration grant unto the said George Fry, Carl Daniel Ekman, and William Bancroft Espeut, their executors, administrators, and assigns, the exclusive enjoyment and advantage of the said invention or improvement, for and during the term of fourteen years from the date hereof; to have, hold, and exercise unto the said George Fry, Carl Daniel Ekman, and William Bancroft Espeut, their executors, administrators, and assigns, the exclusive enjoyment and advantage thereof, for and during and unto the full end and term of fourteen years from the date of these presents next and immediately ensuing, and fully to be complete and ended: Provided always, that if the said George Fry, Carl Daniel Ekman, and William Bancroft Espeut shall not, within three days after the granting of these Letters of Registration, register the same in the proper office in the Supreme Court, at Sydney, in the said Colony of New South Wales, then these Letters of Registration, and all advantages whatsoever hereby granted, shall cease and become void.

In witness whereof, I have hereunto set my sign manual, and have caused the present Letters of Registration to be sealed with the seal of the said Colony of New South Wales, at Government House, Sydney, in New South Wales, this eighth day of August, in the year of our Lord one thousand eight hundred and eighty-three.

[L.S.]

AUGUSTUS LOFTUS.

*Improvements in the Extraction of Saccharine matter from Vegetable substances.*

SPECIFICATION of GEORGE FRY, of 57½, Old Broad-street, in the City of London, England, merchant, CARL DANIEL EKMAN, of Bergirk, in Sweden, chemist, and WILLIAM BANCROFT ESPEUT, of the Island of Jamaica, for an invention entitled "Improvements in the Extraction of Saccharine matter from Vegetable substances."

THE object of this invention is the extraction from sugar-cane, and from other vegetable substances containing saccharine matter, of a larger percentage of sugar than is obtained by the methods commonly practised, accompanied by less than the usual amounts of impurity.

A method of carrying into effect this invention when applied to fresh sugar-canes is as follows:—

The canes (prepared in the usual way for manufacture) are cut into such pieces that they may be properly penetrated by the liquid in the boiling operation, hereafter to be described, or they may be crushed, broken, or otherwise mechanically treated, to effect the same object.

In this state they are placed in a boiler or vessel constructed of or lined with lead or other metal or substance capable of resisting the action of the boiling solution and of the chemicals employed.

This vessel or boiler must be so constructed as to be capable of being heated in a gradual and suitable manner (such as, for example, by means of a steam jacket), of sufficient strength to resist the pressure required for the operation, and of a form convenient for filling and discharging.

The canes, prepared as described, are placed in this vessel or boiler, with as little delay and exposure to the atmosphere as possible, and it is filled with them to such an extent that they may be covered by the boiling liquid, and yet that a steam space may be left. The boiling liquid, of a composition hereafter described, is then run in so as to cover the canes. The boiler or vessel is then made tight, in the usual way, and the temperature is gradually raised until the pressure exceeds that of the atmosphere. The pressure during, and the duration of, the boiling operation, must depend much upon the character and nature of the canes or other vegetable substances treated, and other considerations hereafter referred to.

The solution employed in the boiling operation consists of water containing sulphurous acid and magnesia, soda, potash, or other suitable base.

When the object has been to extract crystallizable sugar, good results have been obtained by using one equivalent of sulphurous acid and one equivalent of magnesia, and boiling at a pressure of about 15 pounds to the square inch.

But when the quality of the sugar is not so material, solutions containing a relatively larger proportion of sulphurous acid, and pressure exceeding that above named, may be used. Acid sulphites and high temperatures, however, have a tendency to invert and destroy the sugar.

A solution containing more base than the quantity sufficient to form one equivalent to the sulphurous acid, may in some cases be used with success, but, as a rule, the proportions which form the normal sulphite are preferred.

The strength of the solution which has been used with success is one containing about one-half to 1 per cent. of the weight of the canes of normal sulphite of magnesia; but it will be understood that the invention is not confined to this proportion.

Beet-roots may be treated in a similar manner to that above described for sugar-canes.

In treating a raw material, regard must be had to its character and condition. If a substance is hard and compact it will require higher pressure to effect the same amount of disintegration and consequent perfect extraction of its saccharine constituents in a given time; and given the same chemicals and pressure, the duration of the boiling will have an effect in obtaining more complete extraction. But on the other hand it must be borne in mind that high temperatures, acid solutions, and long boiling have, both separately and jointly, a tendency to invert and (carried to extremes) to destroy sugar. In operating, therefore, some judgment must be exercised in order to obtain the best results.

After the completion of the boiling process, the liquid may be separated from the solid or pulpy matter by mechanical or other means. The liquid will be found to contain (if the operation has been properly performed) a very large proportion of the saccharine matter contained in the raw material, and it may be treated in any suitable manner to obtain the sugar in a crystallized form; or, if the operation has been so performed that the sugar is more or less inverted, it may be utilized by fermentation and distillation, or by other suitable means.

## CLAIM.

The extraction of sugar from vegetable substances by boiling under pressure with a solution containing sulphurous acid and a base or alkali.

In witness whereof, we, the said George Fry, Carl Daniel Ekman, and William Bancroft Espeut, have hereunto set our hands and seals, this second day of June, 1883.

Witness,—

EDWD. WATERS,  
Melbourne, Patent Agent.

GEORGE FRY.  
CARL DANIEL EKMAN.  
WILLIAM BANCROFT ESPEUT.  
(Per JOHN M'ILWRAITH, jun., their Agent).

This is the specification referred to in the annexed Letters of Registration granted to George Fry, Carl Daniel Ekman, and William Bancroft Espeut, this eighth day of August, A.D. 1883.

AUGUSTUS LOFTUS.

## REPORT.

Sir,

The application of Messrs. George Fry, Carl Daniel Ekman, and William Bancroft Espeut, for Letters of Registration for an invention entitled "Improvements in the Extraction of Saccharine matter from Vegetable substances" having been referred to us, we have the honor to report that we have examined the specification accompanying the same, and see no objection to the issue of Letters of Registration as prayed for.

The Under Secretary of Justice.

Sydney, 13 June, 1883.

We have, &c.,  
A. LEIBIUS.  
CHAS. WATT.



A.D. 1883, 8th August. No. 1288.

**IMPROVEMENTS IN GALVANIC BATTERIES AND ELECTRO-CHEMICAL  
ACCUMULATORS.**

LETTERS OF REGISTRATION to Rookes Evelyn Bell Crompton and Desmond Gerald FitzGerald, for Improvements in Galvanic Batteries and Electro-Chemical Accumulators.

[Registered on the 10th day of August, 1883, in pursuance of the Act 16 Vic. No. 24.]

BY HIS EXCELLENCY THE RIGHT HONORABLE SIR AUGUSTUS WILLIAM FREDERICK SPENCER LOFTUS (commonly called LORD AUGUSTUS LOFTUS) Knight Grand Cross of the Most Honorable Order of the Bath, a Member of Her Majesty's Most Honorable Privy Council, Governor and Commander-in-Chief of the Colony of New South Wales and its Dependencies.

TO ALL TO WHOM THESE PRESENTS SHALL COME, greeting :

WHEREAS ROOKES EVELYN BELL CROMPTON, of Mansion-House Buildings, Queen Victoria-street, in the city of London, England, engineer, and DESMOND GERALD FITZGERALD, of No. 6, Ackerman Road, Brixton, in the county of Surrey, England, electrician, have by their Petition humbly represented to me that they are the authors or designers of a certain invention or improvement in manufactures, that is to say, of an invention entitled "Improvements in Galvanic Batteries and Electro-Chemical Accumulators," which is more particularly described in the specification which is hereunto annexed; and that they, the said Petitioners have deposited with the Honorable the Treasurer of the said Colony of New South Wales the sum of Twenty Pounds sterling, for defraying the expense of granting these Letters of Registration, as required by the Act of Council, sixteenth Victoria, number twenty-four; and have humbly prayed that I would be pleased to grant Letters of Registration, whereby the exclusive enjoyment and advantage of the said invention or improvement might be secured to them for a period of fourteen years: And I, being willing to give encouragement to all inventions and improvements in the arts or manufactures which may be for the public good, and having received a report favourable to the prayer of the said Petition, from competent persons appointed by me to examine and consider the matters stated therein, and to report thereon for my information, am pleased, with the advice of the Executive Council, and in exercise of the power and authority given to me by the said Act of Council, to grant, and do by these Letters of Registration grant unto the said Rookes Evelyn Bell Crompton and Desmond Gerald FitzGerald, their executors, administrators, and assigns, the exclusive enjoyment and advantage of the said invention or improvement, for and during the term of fourteen years from the date hereof; to have, hold, and exercise unto the said Rookes Evelyn Bell Crompton and Desmond Gerald FitzGerald, their executors, administrators, and assigns, the exclusive enjoyment and advantage thereof, for and during and unto the full end and term of fourteen years from the date of these presents next and immediately ensuing, and fully to be complete and ended: Provided always, that if the said Rookes Evelyn Bell Crompton and Desmond Gerald FitzGerald shall not, within three days after the granting of these Letters of Registration, register the same in the proper office in the Supreme Court, at Sydney, in the said Colony of New South Wales, then these Letters of Registration, and all advantages whatsoever hereby granted, shall cease and become void.

In witness whereof, I have hereunto set my sign manual, and have caused the present Letters of Registration to be sealed with the seal of the said Colony of New South Wales, at Government House, Sydney, in New South Wales, this eighth day of August, in the year of our Lord one thousand eight hundred and eighty-three.

[L.S.]

AUGUSTUS LOFTUS.

*Improvements in Galvanic Batteries and Electro-Chemical Accumulators.*

SPECIFICATION of ROOKES EVELYN BELL CROMPTON, of Mansion-House Buildings, Queen Victoria-street, in the city of London, England, engineer, and DESMOND GERALD FITZGERALD, of No. 6, Ackeman Road, Brixton, in the county of Surrey, England, electrician, entitled "Improvements in Galvanic Batteries and Electro-Chemical Accumulators."

THIS invention relates to the construction of the electrodes of galvanic batteries, especially of the type known as secondary batteries or electro-chemical accumulators. In these batteries it is desirable to increase as much as possible the surface of the electrodes, and sometimes to give to them a structure which permits of large quantities of gas being occluded or retained at or near the surface.

We accomplish this by giving to the electrodes a highly porous structure, and otherwise extending their surface in the following manner:—The electrode is made of a mixture or alloy of lead and some other substance capable of being extracted and removed therefrom by the action of water, acids, or other chemical agents, or by heat, or by electrolysis.

When, by fusion, compression, or otherwise, the mixture has been made into a shape suitable for the electrode, the foreign substance is removed wholly or partially by some of the means hereinbefore referred to, and the lead of the electrode is left with a porous structure which greatly increases the surface exposed to the electrolyte when it is made to form part of a secondary battery.

The method which we prefer to use is to take an alloy of lead and some suitable metal, such as sodium, potassium, or zinc, or a compound alloy of lead with two of the above substances. The alloys of lead and sodium may be cheaply made by exposing a mixture of litharge and carbonate of soda to a strong heat in a covered crucible, and a similar plan may be adopted to procure the alloy of lead and potassium; but, in general, the alloys are most conveniently made by fusing together lead and the other component metals.

These alloys may be cast into the desired shape; but, if they are malleable or ductile, they may be rolled out or pressed into plates of the form required, or drawn out into wires, which may be coiled in any convenient shape to form electrodes, either, or both wire or plate, being treated as before described, so as to leave the lead as a porous structure.

These plates or wires may be used either naked or covered with silk, cotton, or other suitable substance, to prevent contact.

We also form compound electrodes by covering a plate of some suitable metal with plates of some of the alloys above spoken of.

Such compound electrodes may also be made by immersing a plate of such a metal into the alloy while in a state of fusion, or into an amalgam of such an alloy. Similarly, by covering a cylinder of some suitable metal with one of the above-mentioned alloys, which is ductile, and drawing out the bar so formed, a compound wire may be made with an outer covering of the alloy.

In all cases, after the electrode is formed or has been made into a shape sufficiently near to the form it will have in the battery, the component or components of the alloy, other than lead, are wholly or partially removed by one of the methods hereinbefore referred to. If it is to be removed by electrolysis, this is effected by making the plate the anode of a depositing cell.

The method to be chosen for removing the other component depends on its nature. If it be soluble in water or any acid or other chemical reagent which does not attack lead, the removal will be effected by exposing it to the action of water, or of such acid or reagent; but if it be a metal, it will generally be found to be most easily removed by electrolysis.

A salt, such as ammoniac sulphate in powder, may be brought into admixture with lead in a state of subdivision and dissolved out by water. Chalk or magnesia, in similar admixture, would be dissolved out by an acid. Metals are removed preferably by electrolysis.

We also in some cases perforate the electrodes, so as to give still greater surface and to reduce the weight, even to the extent of making the electrode take the form of a grating or strainer.

It is not necessary that the two electrodes of the battery should be alike in size or perforations, but these can be varied so as to get the maximum efficiency for the smallest weight.

The surfaces of the electrodes may be amalgamated.

The above method is preferably applied to secondary batteries of the Planté type, where the electrodes are of lead; but it may be also applied to secondary batteries, where the electrodes are of metal other than lead, or to any batteries where it is desirable to give very large surface to the electrodes or either of them.

If the component, other than the metal of which the electrode is to be formed, is itself not a metal, so that the two do not form an alloy, a similar method is employed; but, as has been above stated, it will rarely be found to be removable by electrolysis.

The mixture is formed by any suitable means into electrodes of suitable shape and the other component is then removed from the metal (wholly or partially) by the action of water, acids, or other chemical agents, or by heat. The various subsidiary treatments given above can also be applied to this method so far as the nature of the substances permits.

It is not necessary that the mixture of the metal of the electrode and the other component should be obtained by fusion. It is often convenient to obtain it by intimate mechanical mixture of the materials in a finely divided state, sufficient cohesion being obtained by consolidating them under pressure, or by heating them to such a temperature that a pasty condition is obtained, or by a combination of the two methods.

More than one of the various methods above described may in some cases be advantageously employed in the preparation of the same electrode. For instance, it may be found convenient to commence by removing the other components, or one of them, by heat from the outer surface and continuing the operation by a chemical reagent, or by electrolysis, or both.

When we use manganese dioxide ( $Mn. O_2$ ) as the other ingredient in the mixture with finely divided lead, the electrode containing lead and dioxide of manganese should first be made a cathode, in order to reduce the manganese dioxide to a lower degree of oxidation. Afterwards, it may be made an anode, in order to dissolve out the manganese as sulphate, the electrolyte being dilute sulphuric acid.

We

*Improvements in Galvanic Batteries and Electro-Chemical Accumulators.*

We are aware that it has been proposed to apply electrolysis to the preparation of electrodes, by removing thereby the tin from an alloy of lead and tin. We, therefore, do not claim generally the use of electrolysis in the preparation of electrodes for removing one component from an alloy, nor do we claim the use of an alloy of lead and tin for such purpose. Moreover, we have found that tin is very unsuitable for the purposes described, on account of the extreme difficulty of extracting the whole of it thoroughly by electrolysis, and it is necessary so to do to prevent the formation of crystals or aggregations of metal which lead to short-circuiting.

But what we do claim as our invention is as follows:—

First—The method of obtaining in an electrode a porous structure offering large surface, by the removal through solution, chemical action, or heat, of a component originally brought into a condition of intimate admixture or combination with the permanent component of the electrode, substantially as hereinbefore set forth.

Second—The preparation of porous electrodes by the removal, through electrolysis, of sodium, potassium, zinc, cadmium, iron, antimony, copper, or silver, from mixtures or alloys of one or more of these metals with lead, substantially as herein described.

Third—The construction of electrodes by the compression of mixtures containing lead in a subdivided state, together with a component or components to be removed by solution or otherwise, substantially as hereinbefore set forth.

In witness whereof, we, the said Rookes Evelyn Bell Crompton and Desmond Gerald FitzGerald, have hereunto set our hands and seals, this fourth day of May, A.D. 1883.

R. E. B. CROMPTON.  
D. G. FITZGERALD.

This is the specification referred to in the annexed Letters of Registration granted to Rookes Evelyn Bell Crompton and Desmond Gerald FitzGerald, this eighth day of August, A.D. 1883.

AUGUSTUS LOFTUS.

---

REPORT.

Sir,

We do ourselves the honor to report, in reply to your blank cover of the 15th instant, No. 7,388, that we are of opinion Letters of Registration may be granted in favour of Messrs. Rookes Evelyn Bell Crompton and Desmond Gerald FitzGerald for an invention entitled "Improvements in Galvanic Batteries and Electro-chemical Accumulators," in terms of their Petition, specification, and claim.

We have, &c.,

E. C. CRACKNELL.  
GOTHER K. MANN.

The Under Secretary of Justice.

---



A.D. 1883, 8th August. No. 1289.

A NEW OR IMPROVED AMALGAMATING APPARATUS.

LETTERS OF REGISTRATION to Alfred Kirby Huntington and Walter Edward Koch, for an Invention entitled "A New or Improved Amalgamating Apparatus."

[Registered on the 10th day August, 1883, in pursuance of the Act 16 Vic. No. 24.]

BY HIS EXCELLENCY THE RIGHT HONORABLE SIR AUGUSTUS WILLIAM FREDERICK SPENCER LOFTUS (commonly called LORD AUGUSTUS LOFTUS), Knight Grand Cross of the Most Honorable Order of the Bath, a Member of Her Majesty's Most Honorable Privy Council, Governor and Commander-in-Chief of the Colony of New South Wales and its Dependencies.

TO ALL TO WHOM THESE PRESENTS SHALL COME, greeting :

WHEREAS ALFRED KIRBY HUNTINGTON, of Hampstead, and WALTER EDWARD KOCH, of Kensington, both in the county of Middlesex, England, have by their Petition humbly represented to me that they are the authors or designers of a certain invention or improvement in manufactures, that is to say, of an invention entitled "A new or improved Amalgamating Apparatus," which is more particularly described in the specification marked "A," and the two sheets of drawings marked "B" and "C" respectively, which are hereunto annexed; and that they, the said Petitioners, have deposited with the Honorable the Treasurer of the said Colony of New South Wales the sum of Twenty Pounds sterling for defraying the expense of granting these Letters of Registration, as required by the Act of Council sixteenth Victoria number twenty-four; and have humbly prayed that I would be pleased to grant Letters of Registration, whereby the exclusive enjoyment and advantage of the said invention or improvement might be secured to them for a period of fourteen years: And I, being willing to give encouragement to all inventions and improvements in the arts or manufactures which may be for the public good, and having received a report favourable to the prayer of the said Petition, from competent persons appointed by me to examine and consider the matters stated therein, and to report thereon for my information, am pleased, with the advice of the Executive Council, and in exercise of the power and authority given to me by the said Act of Council, to grant, and do by these Letters of Registration grant unto the said Alfred Kirby Huntington and Walter Edward Koch, their executors, administrators, and assigns, the exclusive enjoyment and advantage of the said invention or improvement for and during the term of fourteen years from the date hereof; to have, hold, and exercise unto the said Alfred Kirby Huntington and Walter Edward Koch, their executors, administrators, and assigns, the exclusive enjoyment and advantage thereof, for and during and unto the full end and term of fourteen years from the date of these presents next and immediately ensuing, and fully to be complete and ended: Provided always that if the said Alfred Kirby Huntington and Walter Edward Koch shall not, within three days after the granting of these Letters of Registration, register the same in the proper office in the Supreme Court, at Sydney, in the said Colony of New South Wales, then these Letters of Registration and all advantages whatsoever hereby granted shall cease and become void.

In witness whereof, I have hereunto set my sign manual, and have caused the present Letters of Registration to be sealed with the seal of the said Colony of New South Wales, at Government House, Sydney, in New South Wales, this eighth day of August, in the year of our Lord one thousand eight hundred and eighty-three.

[L.S.]

AUGUSTUS LOFTUS.

*A New or Improved Amalgamating Apparatus.*

SPECIFICATION of ALFRED KIRBY HUNTINGTON, of Hampstead, and WALTER EDWARD KOCH, of Kensington, both in the county of Middlesex, England, for an invention, entitled "A new or improved Amalgamating Apparatus."

OUR invention relates to apparatus for separating, by amalgamation, particles of precious metal from pulverised ores or tailings, the object which we have in view being to provide for thorough exposure of these particles to the action of the amalgamating metal, and for conducting the amalgamation as a continuous operation. We will describe the apparatus according to our invention, referring to the accompanying drawings.

Fig. 1 is a vertical section of the whole apparatus; fig. 2 is a sectional plan of the same, on the line XX of fig. 1; figs. 3, 4, 5, and 6, show, to an enlarged scale, the construction of one of the tubular arms K—that is to say, fig. 3 is an elevation of the arm, fig. 4 is a plan thereof, and figs. 5 and 6 are transverse sections at Y Y and Z Z respectively.

A is the pan or cylindrical vessel in which the amalgamation takes place. At the bottom it has an outlet pipe B for running off the liquid amalgam, and near the top it has an outlet C for discharging the ore or material from which the precious metal has been extracted; D is the cover of the pan. A pipe E, having at the top a funnel mouth F, is mounted to revolve on a pivot G at the bottom of the pan, and in a bearing H formed in the cover. It is driven by a belt on a pulley I, or by other suitable gearing. At the bottom of the pipe E are two radial branch pipes as shown in figures 3, 4, 5, and 6, each of these having along one side of it a long slit or aperture *k*. The funnel F is made with an internal lip *f* inclined inwards and downwards. Part of the pipe E within the pan is surrounded by a stationary sleeve L, which is supported from the side of the pan by ribs *l*. On the pipe E, above the sleeve L, is fixed a backwardly curved arm M, having pins or tines projecting down from it.

The pan A being charged with the amalgamating metal up to about the level *a*, the pipe E is caused to revolve in the direction of the arrow N, and the pulverised ore or tailings to be operated on being fed into the funnel F (whence the lip *f* prevents it from being ejected) descends the pipe E, and issues by the lateral slits *k* from the radial branches K. The ore ascends in a subdivided condition through the amalgamating metal (which extracts the particles of the precious metal) and collects at the upper part of the pan. The tines of the arm M rake the material, and the re-curved arm ejects it through the aperture C. When the amalgamating metal in the pan is sufficiently saturated, it is run off by the pipe B, by opening a suitable cock, valve, or plug.

In many cases it is desirable to pass the ore or tailings several times through the amalgamating metal. This may be done by employing several sets of the amalgamating apparatus which we have described, feeding the second with the material discharged from the first, the third with that discharged from the second, and so on; or, when only one set of the amalgamating apparatus is available, the material discharged from it may be elevated and again fed into its funnel mouth; and this may be repeated as often as desired. In order, however, to avoid in such cases complexity of apparatus, and labour in moving or elevating the material operated on, we modify the apparatus as shown in the vertical section, figure 7, and sectional plan, figure 8, taken on the line X X, figure 7. We make a lateral slit *e* in the tube E, and at the level of *e* we fix on the tube a blade P, curved forward in the direction of revolution. We feed a quantity of the ore or tailings through the hopper O, and the blade P guides portions of the material continuously to the slit *e*, by which they enter the tube E. They descend the tube, and are ejected from the slits *k* of its arms K. They rise through the amalgamating metal, are again guided to the slit *e*, and so on continuously, being thus made to circulate as often as desired through the amalgamating metal. When the metal is thus treated as long as necessary, a door or shutter closing the outlet C is opened, and the pipe E being made to revolve in the direction opposite to the arrow, its curved blade P ejects the greater part of the material. The outlet C is then closed, and a fresh quantity of material being fed through the hopper O or down the pipe E, the pipe E and its blade P are again made to revolve in the direction of the arrow and the action is repeated.

The apparatus above described may be employed for amalgamating with mercury at ordinary temperatures, in which case the pan A might be made of wood or other suitable material not acted on by mercury. Or it may be employed for amalgamating with molten lead or other suitable molten metal, in which case the pan A is made of iron, or of refractory material, and set in a furnace-flue, so as to be kept sufficiently heated to maintain the molten metal in a liquid condition. In order to prevent oxidation of the molten metal, a reducing atmosphere, such as combustible gas, from a producer is supplied to the pan by a pipe opening through the cover of the pan.

Having thus described the nature of our invention, and the best means we know for carrying it out in practice, we claim—

An amalgamating apparatus, consisting of a pan or cylindrical vessel A, in combination with a pipe E, mounted to revolve centrally within the vessel, and having at its lower end radial branch pipes K, with lateral apertures *k*, substantially as and for the purposes herein set forth.

In witness whereof, we, the said Alfred Kirby Huntington and Walter Edward Koch, have hereunto set our hands and seals this nineteenth day of April, in the year of our Lord one thousand eight hundred and eighty-three.

ALFRED KIRBY HUNTINGTON.  
WALTER EDWARD KOCH.

Witness,—OLIVER IMRAY.

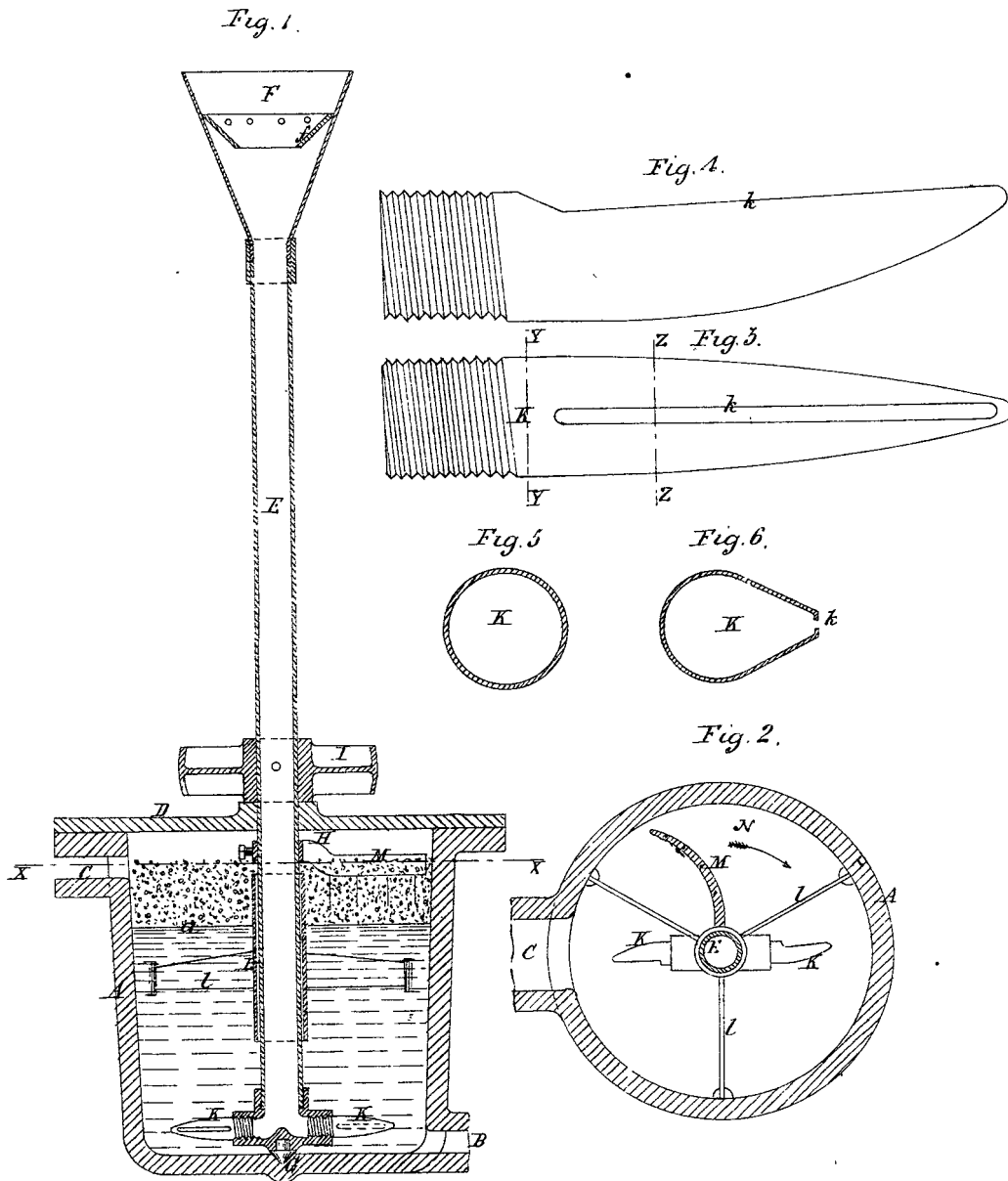
This is the specification marked "A" referred to in the annexed Letters of Registration granted to Alfred Kirby Huntington and Walter Edward Koch, this eighth day of August, A.D. 1883.

AUGUSTUS LOFTUS.

REPORT.







*This is the Sheet of Drawings marked B preferred to in the annexed Letters of Registration granted to Alfred Kirby Huntington and Walter Edward Koch, this eighth day of August, A.D. 1883. Augustus Loftus.*

PHOTO-LITHOGRAPHED AT THE GOVT. PRINTING OFFICE, SYDNEY NEW SOUTH WALES.

Fig. 7.

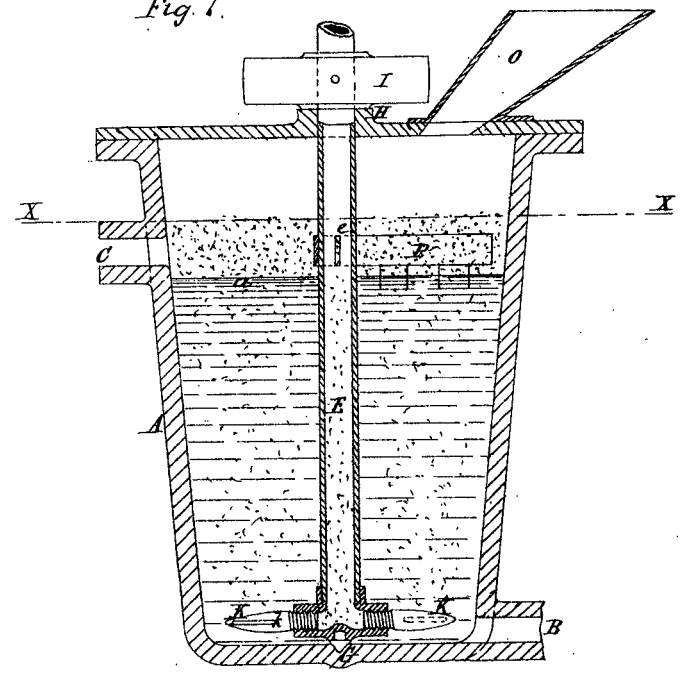
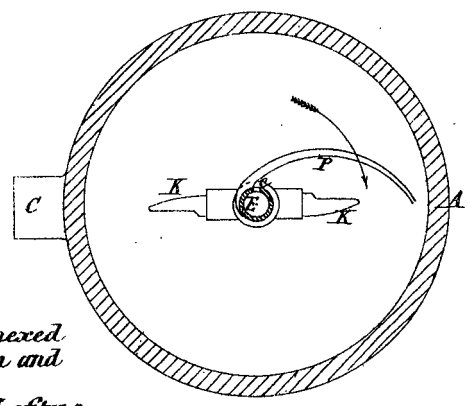


Fig. 8.



*This is the Sheet of Drawings marked C referred to in the annexed Letters of Registration granted to Alfred Kirby Huntington and Walter Edward Koch, this eighth day of August, A.D. 1883.*  
*Augustus Loftus.*



A.D. 1883, 8th August. No. 1290.

**IMPROVEMENTS IN SECONDARY BATTERIES FOR ELECTRIC CURRENTS.**

LETTERS OF REGISTRATION to Charles Henry Walker Biggs and William Worby Beaumont, for Improvements in Secondary Batteries for the Production, Conservation, and Regulation of Electric Currents.

[Registered on the 10th day of August, 1883, in pursuance of the Act 16 Vic. No. 24.]

BY HIS EXCELLENCY THE RIGHT HONORABLE SIR AUGUSTUS WILLIAM FREDERICK SPENCER LOFTUS (commonly called LORD AUGUSTUS LOFTUS) Knight Grand Cross of the Most Honorable Order of the Bath, a Member of Her Majesty's Most Honorable Privy Council, Governor and Commander-in-Chief of the Colony of New South Wales and its Dependencies.

TO ALL TO WHOM THESE PRESENTS SHALL COME, greeting:

WHEREAS CHARLES HENRY WALKER BIGGS and WILLIAM WORBY BEAUMONT, both of the Strand, in the County of Middlesex, England, have by their Petition humbly represented to me that they are the authors or designers of a certain invention or improvement in manufactures, that is to say, of an invention entitled "Improvements in Secondary Batteries for the Production, Conservation, and Regulation of Electric Currents," which is more particularly described in the specification and the sheet of drawings which are hereunto annexed, and that they the said Petitioners have deposited with the Honorable the Treasurer of the said Colony of New South Wales the sum of Twenty Pounds sterling, for defraying the expense of granting these Letters of Registration, as required by the Act of Council, sixteenth Victoria, number twenty-four; and have humbly prayed that I would be pleased to grant Letters of Registration whereby the exclusive enjoyment and advantage of the said invention or improvement might be secured to them for a period of fourteen years: And I, being willing to give encouragement to all inventions and improvements in the arts or manufactures which may be for the public good, and having received a report favourable to the prayer of the said Petition, from competent persons appointed by me to examine and consider the matters stated therein and to report thereon for my information, am pleased, with the advice of the Executive Council, and in exercise of the power and authority given to me by the said Act of Council, to grant, and do by these Letters of Registration grant unto the said Charles Henry Walker Biggs and William Worby Beaumont, their executors, administrators, and assigns, the exclusive enjoyment and advantage of the said invention or improvement for and during the term of fourteen years from the date hereof; to have, hold, and exercise unto the said Charles Henry Walker Biggs and William Worby Beaumont, their executors, administrators, and assigns the exclusive enjoyment and advantage thereof for and during and unto the full end and term of fourteen years from the date of these presents next and immediately ensuing, and fully to be complete and ended. Provided always, that if the said Charles Henry Walker Biggs and William Worby Beaumont, shall not, within three days after the granting of these Letters of Registration, register the same in the proper office in the Supreme Court, at Sydney, in the said Colony of New South Wales, then these Letters of Registration, and all advantages whatsoever hereby granted, shall cease and become void.

In witness whereof, I have hereunto set my sign manual, and have caused the present Letters of Registration to be sealed with the seal of the said Colony of New South Wales, at Government House, Sydney, in New South Wales, this eighth day of August, in the year of our Lord one thousand eight hundred and eighty-three.

[L.S.]

AUGUSTUS LOFTUS.

*Improvements in Secondary Batteries for Electric Currents.*

SPECIFICATION of CHARLES HENRY WALKER BIGGS and WILLIAM WORBY BEAUMONT, both of the Strand, in the County of Middlesex, entitled "Improvements in Secondary Batteries for the Production, Conservation, and Regulation of Electric Currents."

OUR said invention relates to improvements in secondary batteries for the production, conservation, and regulation of electric currents.

In the usual form of secondary batteries the products of electric decomposition appearing at the poles of the charging battery, or dynamo machine are collected and retained in the charged battery itself.

Now, according to our invention, we prevent loss of these products, or one of them, by collecting them in a separate holder or holders, separate or otherwise from the holder containing the electrodes of the battery, and we then recombine them in the quantities required to produce, regulate, or augment the electric current. If the electrodes are properly made, and properly proportioned, there is no loss of the products of decomposition, except when the charging current is kept on too long, or is too strong, but it is important that such loss should be prevented.

For example, in charging a secondary battery, and especially those batteries which are provided with the electrodes, made wholly or partly of solid, or ordinary homogeneous metallic lead, hydrogen will be formed more rapidly than it can be occluded in the nascent state by the negative electrode if the electric current has too great an electro-motive force, or if the battery is charged too quickly by too great a current, and this hydrogen escapes in the gaseous form.

Now, we collect, and thus minimise or prevent the complete loss of this product, in one of the holders hereinbefore mentioned, and we place electrodes in another holder, vessel, or cell containing a suitable solution, such as dilute sulphuric acid. One of each pair of these electrodes retains the other product, virtually oxygen, which combines with the lead of the electrode, forming peroxide of lead; and this electrode is itself made of porous lead, so that it presents the greatest possible surface to the action of the electrolyte. The other electrode of each pair is, in some cases, made in the form of a narrow chamber or chambers of porous lead. The first mentioned electrode is a porous lead plate, or all the electrodes may be porous lead plates.

The product, hydrogen gas, under greater or less pressure, contained in the collecting holder or holders may be allowed to pass by a pipe or pipes into the second holder, or into the chambered porous lead electrode or electrodes contained therein in dilute sulphuric acid, its passage thereto being regulated by cocks in those pipes, or by other suitable or equivalent means, the gas so collected and re-employed being most often used when the electro-motive force of the battery is lowered, or the quantity of current given off is lowered by discharge. The collected gas is then allowed to pass into the hollow porous lead electrode, or electrodes, where it acts as a positive element by which the current given off is somewhat strengthened.

Instead of obtaining the hydrogen in the second holder or holders as a bye-product of the charging of the battery, we may in some cases obtain it by known chemical methods, and charge the holder therewith under a suitable pressure. We may also, in some cases, obtain one of the other products of decomposition, such as oxygen in combination with lead, forming peroxide of lead, by other means than by electric decomposition in the battery, as for instance peroxide of lead obtained by known chemical methods, and charge our chambered porous lead electrodes therewith.

Figure 1 of the accompanying drawings shows one form of our secondary battery constructed with electrodes made as hereinafter more particularly described. Figure 2 is a detail view showing the connection of one of the electrodes with a binding screw and terminal. We cover the holder or vessel A, containing the electrodes N N<sup>1</sup>, with a gas-tight but movable cover B; through holes in this cover, or through the sides of the holder, as here shown in figures 1 and 2, are passed the connecting or conducting wires C, C<sup>1</sup> attached to the electrodes N N<sup>1</sup>, the holes, in which are inserted, the screw c being made gas-tight by suitable commonly known means. The holder A, containing the electrodes and constituting the battery proper, we connect to a second holder D by means of pipes, one of which pipes E, fitted with a cock E<sup>1</sup>, conveys any excess of hydrogen which may be evolved during the charging of the battery by a current through the acidulated water in which the electrodes are immersed into the upper part of the second holder D aforementioned, which is also fitted with a gas-tight but movable cover F. Into the lower part of this second holder D is inserted another pipe, G, which is carried up to the requisite height; so that when it is filled with water it will give the necessary head, so as to maintain a pressure within the holder D, the top of the pipe G being fitted with a cock G<sup>1</sup>, and the holder being in the first place filled with water by means of a cock H in the upper part of the holder or its cover. Another cock m serves to allow of the escape of the air from the holder when first used, or of the gas if required, or to draw off the gas when required for purposes other than those of the battery.

Another pipe I, branching off from the pipe E, and fitted with a cock I<sup>1</sup>, conveys the collected hydrogen by branch pipes I<sup>2</sup> (one or more according to the number of pairs of electrodes) into the chamber or chambers of the hollow or chambered porous lead electrodes in the holder A, constituting the secondary battery proper.

The pipes I<sup>2</sup> should be made of a material not affected by the electrolyte, as for instance, of glass.

In order to intensify, or increase, the action of the hydrogen, we may heat it in its passage to the electrodes N N<sup>1</sup> of the battery. For this purpose we may form the pipe I into a coil, heated by a gas burner or other source of heat, as indicated in dotted lines at J; in such case, and in order to prevent undue or undesirable heating of the electrolyte, which we prefer to maintain at a uniform temperature, or nearly so, we connect it by means of circulating pipes, indicated at K K<sup>1</sup>, with a tank or vessel, as indicated at L, figure 1, holding an acid solution.

The piece of lead or other suitable wire C, figure 2, may be imbedded and compressed into the upper part of our electrodes during the process of compression, or it may be riveted into the lug or ear of the electrode.

Figures 3, 3<sup>A</sup>, 4, 5, 6, and 7 show various forms in which the porous lead electrodes may conveniently be made. Figure 3 is a plate electrode, shown in side and edge view in figure 3<sup>A</sup>. Figure 4 shows an inverted box-shaped electrode. These two forms are also shown in figure 1. Any of the forms of electrodes here shown are applicable to any form or construction of secondary battery.

Any

*Improvements in Secondary Batteries for Electric Currents.*

Any required number of pairs of porous lead electrodes may be employed in the holder, vessel, or cell constituting the secondary battery proper, and they may be alternately connected in what is known as multiple arc, or the holder may be divided into a number of cells, each cell containing a pair of porous lead electrodes, one electrode in each cell being connected to the next electrode in the adjoining cell—that is, connected up in what is known as in series.

The efficiency of any secondary battery depends greatly on the quantity of surface which in a given weight of electrode is presented to the action of the electrolyte in which the electrodes are immersed. This large surface, relative to weight, can be best obtained by giving the material of the electrodes a highly porous structure.

Our porous lead electrodes we construct by mechanical means in the manner which we shall now proceed to describe. In making our chambered electrodes we place in the lower part of a bottomless die or mould of the necessary form, resting on a plate of metal, a quantity or layer of lead in a state of fine subdivision. We then place in the die and upon this layer one, two, or more tapered cores of metal. The spaces between these cores and the whole of the interior of the die are then filled up with the lead in a state of fine subdivision, and an upper die is then placed so as just to enter the lower die. The lower die, the plate it rests on and its contents, together with the upper die, are then placed upon, or in a press, such as a hydraulic press, or press like a large photographer's press, with sliding table, and the contents of the die are pressed into a firmly coherent, but porous mass or form. The metal cores are afterwards removed.

In making our porous lead plates we simply place a quantity or layer of the necessary thickness of finely divided lead into the die; then place thereon the upper die, and press it, under a pressure sufficient to convert it into a firmly coherent but porous plate, by some suitable mechanical means as already described. In some cases we make the layer of finely divided lead thicker along the margins, and also along lines traversing the layer, so that when the layer is pressed into a firmly coherent cake or plate it is harder where the layer was thickest, and thus the plate may be made stronger than when pressed from a layer of uniform thickness. In some cases, we imbed at one corner or one edge of the layer of finely divided lead, before pressing, the end of a piece of lead wire, the other part of which projects out of the die, the object being to fasten to the electrode by this means a piece of round or flattened wire, for the purpose of connecting the plates together in a battery. We find that a pressure of from about 400 lb. to about 1,000 lb. per square inch of area of the die is sufficient to make the finely divided lead firmly coherent, and confer upon it sufficient strength, still leaving it in the form of a porous lead structure.

The lead in a state of a fine subdivision, of which, by compression into suitable forms as hereinbefore described, we make our electrodes, may be obtained by one or other of several commonly known methods. That which we have most used, and perhaps that which is most commonly known, is that of precipitation from a solution of acetate or sugar of lead, in which solution is placed a piece or pieces of zinc. The lead in a state of fine subdivision is deposited on this zinc, and from it may be shaken off into the bath containing the solution, and then placed into a die; or it may be shaken direct into dies or moulds, in which it may be compressed in the manner and for the purposes already described.

In using this finely divided lead in the manner and for the purpose herein described, care must be taken that it is not allowed to become too much oxidized by exposure to air; but in order to hinder or to prevent a too complete metallic union of the particles, it is advantageous to expose it to the air before compression into the form of an electrode, for a period of from an hour or a few hours to a day or so, or to treat it superficially by chemical means, such as by contact with dilute sulphuric acid.

By the employment of electrodes made according to our invention wholly of porous lead in the manner herein set forth, we obtain very extended surface at which lead becomes oxidized or otherwise converted, and subsequently reduced by the action of nascent hydrogen, this being one of the products of electric decomposition, and we thus obviate that loss of hydrogen which sometimes takes place when electrodes made wholly or partly of ordinary metallic lead are employed.

We may, in some cases, construct the negative electrode of our secondary batteries of metal other than lead, such as copper, the positive electrode being porous lead. In this case the electrolyte may be a solution of sulphate of copper or dilute sulphuric acid.

Having described the nature of our invention and the manner of performing the same, we declare that what we claim as our invention is—

Firstly—The use, in secondary batteries having one, two, or three gas and liquid-tight holders, vessels, or cells, of the chambered or flat porous lead electrodes, made by compressing finely divided, and preferably partially oxidized, lead alone into cakes, plates, or any other suitable forms, as herein set forth and shown.

Secondly—The construction, and use generally in secondary batteries, of porous lead electrodes, made by compressing lead in a state of fine subdivision, and preferably in a partially or superficially oxidized condition, alone into cakes, plates, or any other suitable form, as herein described.

In witness, whereof, we the said Charles Henry Walker Biggs and William Worby Beaumont, have hereunto set our hands and seals, this fourth day of May, in the year of our Lord one thousand eight hundred and eight-three.

C. H. W. BIGGS.  
W. WORBY BEAUMONT.

This is the specification referred to in the annexed Letters of Registration granted to Charles Henry Walker Biggs and William Worby Beaumont, this eighth day of August, A.D. 1883.

AUGUSTUS LOFTUS.

---

*Improvements in Secondary Batteries for Electric Currents.*

---

REPORT.  

---

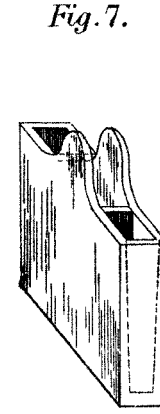
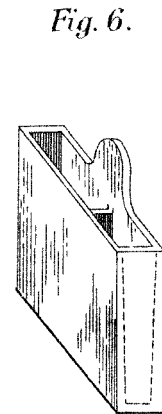
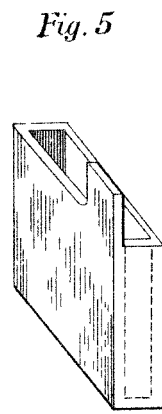
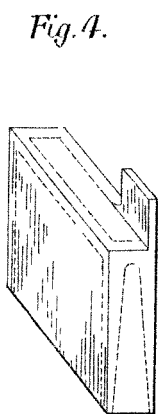
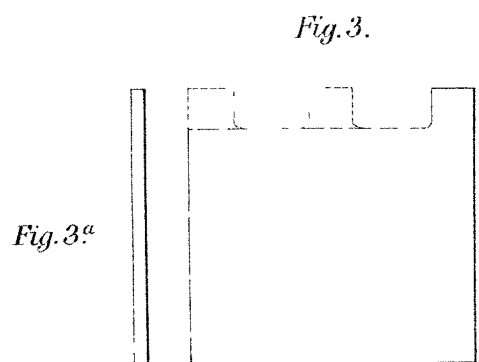
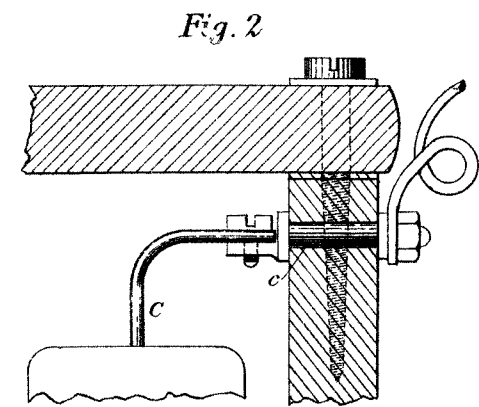
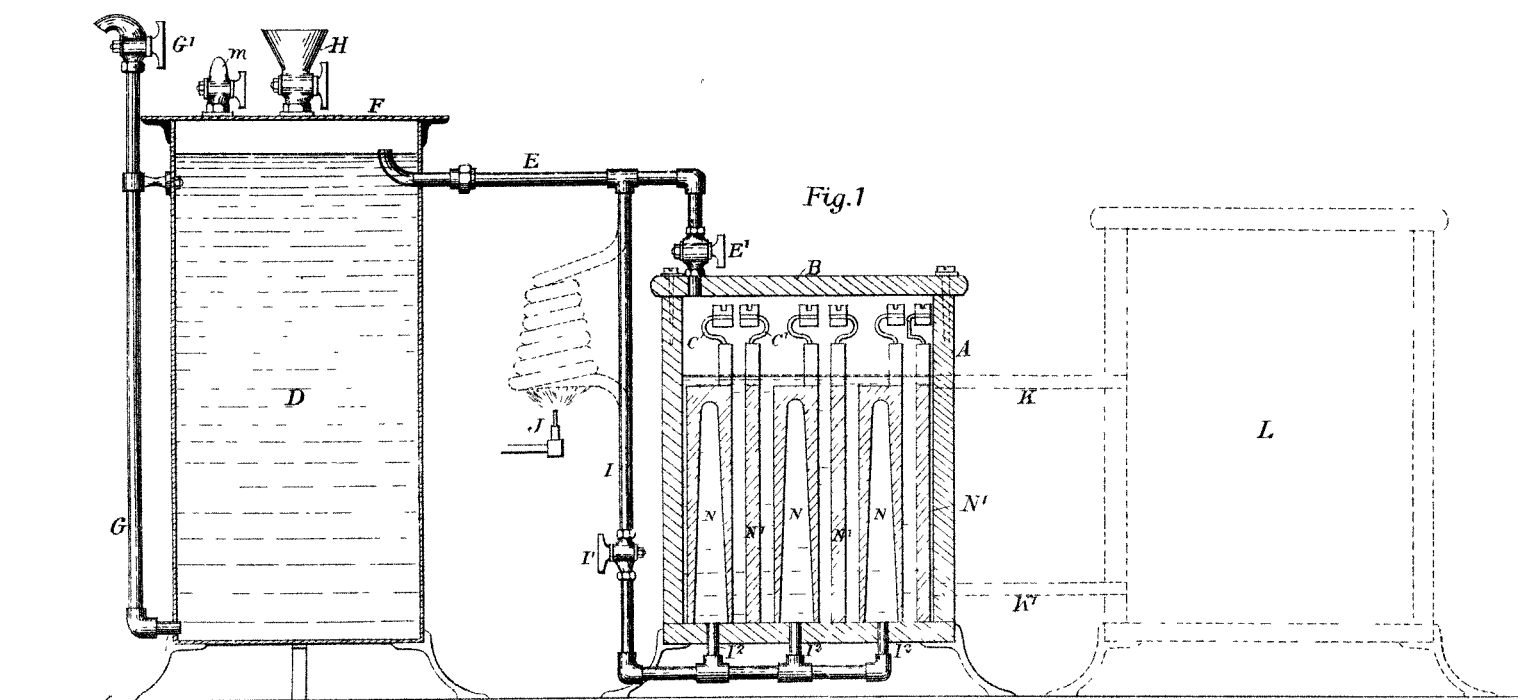
Sir, We do ourselves the honor to report, in reply to your blank cover of 15th instant, No. 7,387, that we are of opinion the Petition of C. H. W. Biggs and W. W. Beaumont for the registration of "Improvements in Secondary Batteries, and for the Production, Conservation, and Regulation of Electric Currents," may be granted in terms of their specification, drawings, and claim.

Sydney, 22 June, 1883.  
We have, &c.,  
E. C. CRACKNELL.  
GOTHER K. MANN.

The Under Secretary of Justice.

---

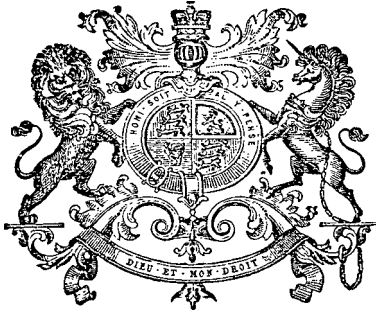
[Drawings—one sheet.]



*This is the Sheet of Drawings referred to in the annexed Letters of Registration granted to Charles Henry Walker Biggs and William Worby Beaumont this eighth day of August, A.D. 1883.*

*Augustus Loftus.*





A.D. 1883, 8th August. No. 1291.

IMPROVEMENTS IN EXTINGUISHING FIRES, &c.

LETTERS OF REGISTRATION to John Kissack Joshua Foster, for Improvements in Extinguishing Fires, and in Apparatus to be employed therefor.

[Registered on the 10th day of August, 1883, in pursuance of the Act 16 Vic. No. 24.]

BY HIS EXCELLENCY THE RIGHT HONORABLE SIR AUGUSTUS WILLIAM FREDERICK SPENCER LOFTUS (commonly called LORD AUGUSTUS LOFTUS), Knight Grand Cross of the Most Honorable Order of the Bath, a Member of Her Majesty's Most Honorable Privy Council, Governor and Commander-in-Chief of the Colony of New South Wales and its Dependencies.

TO ALL TO WHOM THESE PRESENTS SHALL COME, greeting :

WHEREAS JOHN KISSACK JOSHUA FOSTER, of Bolton, in the County of Lancaster, England, hath by his Petition humbly represented to me that he is the author or designer of a certain invention or improvement in manufactures, that is to say, of an invention intitled "Improvements in Extinguishing Fires, and in Apparatus to be employed therefor," which is more particularly described in the specification and the sheet of drawings which are hereunto annexed ; and that he, the said Petitioner, hath deposited with the Honorable the Treasurer of the said Colony of New South Wales the sum of Twenty Pounds sterling, for defraying the expense of granting these Letters of Registration, as required by the Act of Council, sixteenth Victoria, number twenty-four ; and hath humbly prayed that I would be pleased to grant Letters of Registration, whereby the exclusive enjoyment and advantage of the said invention or improvement might be secured to him for a period of fourteen years ; And I, being willing to give encouragement to all inventions and improvements in the arts or manufactures which may be for the public good, and having received a report favourable to the prayer of the said Petition, from competent persons appointed by me to examine and consider the matters stated therein and to report thereon for my information, am pleased, with the advice of the Executive Council, and in exercise of the power and authority given to me by the said Act of Council, to grant, and do by these Letters of Registration grant, unto the said John Kissack Joshua Foster, his executors, administrators, and assigns, the exclusive enjoyment and advantage of the said invention or improvement for and during the term of fourteen years from the date hereof ; to have, hold, and exercise unto the said John Kissack Joshua Foster, his executors, administrators, and assigns, the exclusive enjoyment and advantage thereof, for and during and unto the full end and term of fourteen years from the date of these presents next and immediately ensuing, and fully to be complete and ended : Provided always, that if the said John Kissack Joshua Foster shall not, within three days after the granting of these Letters of Registration, register the same in the proper office in the Supreme Court at Sydney, in the said Colony of New South Wales, then these Letters of Registration, and all advantages whatsoever hereby granted, shall cease and become void.

In witness whereof, I have hereunto set my sign manual, and have caused the present Letters of Registration to be sealed with the seal of the said Colony of New South Wales, at Government House, Sydney, in New South Wales, this eighth day of August, in the year of our Lord one thousand eight hundred and eighty-three.

[L.S.]

AUGUSTUS LOFTUS.

*Improvements in Extinguishing Fires, &c.*

DUPLICATE Specification of JOHN KISSACK JOSHUA FOSTER, of Bolton, in the County of Lancaster, England, for an invention entitled "Improvements in Extinguishing Fires, and in Apparatus to be employed therefor."

My invention relates to a new method of and apparatus for extinguishing fire, by depriving atmospheric air of its oxygen, and vitiating it with the carbonic acid gas and other products of combustion resulting from passing the air through or over a fire, and forcing or drawing the air so vitiated or deprived of its power of supporting combustion into or through the burning structure.

The apparatus for rendering atmospheric air unfit to support combustion, and applying it for the extinction of a fire, comprises one or more fans, blowers, pumps, or other appliances of suitable construction for forcing or exhausting air, combined with a portable furnace, a boiler or other steam generator, and an engine, the former being connected with the fan-casing by pipes in such manner that atmospheric air will be drawn or forced through the furnace, and be thereby deprived of most of its oxygen, and at same time be mixed with the products of combustion so as to become incapable of supporting combustion. The boiler supplies steam for the engine, and also for injecting into the air after it has been passed through the furnace. The pipes conveying the vitiated air from the furnace may be jacketed to cool the air and the pipes, and to utilize the heat for the generation of steam for the purpose last mentioned. The vitiated air, impregnated or not with steam gases or vapours, is conveyed by pipes into the burning structure through a hole made in the door or otherwise, the structure being kept closed as much as possible to prevent the access of air otherwise than through the apparatus; suitable valves and connections are provided for controlling and directing the current of vitiated air as may be required.

Instead of, or in addition to, injecting steam from the boiler, plain water or water holding in solution or mixed with salt, or bisulphide of carbon, or other matters capable of generating gases which do not support combustion, may be injected into the furnace to moderate its heat and assist in extinguishing the burning structure. Instead of an engine, the fan may be driven by manual power.

## DESCRIPTION OF THE DRAWINGS.

The accompanying drawing represents an engine embodying the method of my invention:—

A is a boiler or the jacket of a fire-box, B, in which a fire is burnt for the purpose of vitiating air. It has an up-take C for steam from the boiler or jacket, and another D for the products of combustion from the fire-box B; E is a fan drawing the products of combustion from the fire-box B through a pipe F connecting the up-take D with the fan-casing; G is a similar pipe connecting the steam up-take C with the discharge outlet of the fan.

H H' are throttle valves coupled, so that when H closes the outlet through the chimney, H' opens a passage through F to the fan, and *vice versa*. A similar pair of coupled valves I I' control C and G. S is a small high-pressure boiler supplying steam to an engine K, which drives the fan; its chimney is connected with pipe F by a pipe L, and a similar pair of coupled valves is provided to control the communication. M is the exhaust-pipe of the engine leading to the up-take C below the valve I; N is an opening in the suction-pipe F of the fan, closed by a throttle valve, which is only opened when ordinary pure air is to be admitted to the fan, to clear a room of the vitiated air after a fire. P is the delivery pipe of the fan made of metal in short lengths fitted together telescopically. Other similar telescopic pipes P' may be added on by screw couplings, or the delivery pipe may be otherwise constructed.

The fly-wheel of the engine is connected to the crank shaft by a clutch, so that it may be thrown in and out of gear by a handle r, to enable the fan to be driven by hand, at first by a handle T on the fly-wheel, for the purpose of creating a draught in the furnace of boiler S, the valve H' then being shut, and the fan drawing air through the pipe L.

The engine may be mounted on wheels as shown, or it may be stationary.

What I claim is—

- 1—The herein described method of extinguishing burning structures, which consists in first rendering atmospheric air unfit to support combustion, by forcing it over or through a fire, and then forcing it into the burning structure substantially as herein described.
- 2—The herein described method of extinguishing burning structures, which consists in rendering atmospheric air unfit to support combustion, by first forcing it over or through a fire and then injecting steam into the vitiated air, and finally forcing the mixture of vitiated air and steam into the burning structure, substantially as herein specified.
- 3—The combination of a fire-box and boiler provided with separate up-takes, pipes connected to said up-takes for the conveyance of vitiated air and steam respectively, a fan-blower or pump connected to said pipes, throttle valves to control the thoroughfare through the pipes, and a boiler and steam engine driving the fan-blower or pump, substantially as herein described and shown in the drawing for the purpose specified.
- 4—The combination of the boiler A, fire-box B, up-takes C and D, pipes F and G, fan, blower, or pump E, coupled pairs of throttle valves H H', I I', steam engine K, and high-pressure steam boiler S, substantially as shown and described for the purpose specified.
- 5—In an apparatus for vitiating atmospheric air and rendering it unfit to support combustion, as described, the combination of the up-take of the high-pressure steam boiler by means of the connecting pipe L, coupled throttle valves in said pipe and in the chimney, and the coupled throttle valves H H', with the fan-blower or pump E for urging the fire in the boiler furnace, and rapidly raising steam at first starting, substantially as shown and described.
- 6—The boiler and fire-box A B, high-pressure steam boiler, and engine S K, fan-blower or pump E, pipes F G connecting boiler A and fire-box B with the fan-blower or pump, and their various appurtenances combined for operation as herein shown and described, and mounted on or combined with a wheeled supporting frame, substantially as shown and described.

In

---

*Improvements in Extinguishing Fires, &c.*

---

In witness whereof, I, the said John Kissack Joshua Foster, have hereunto set my hand and seal, this tenth day of April, in the year of our Lord 1883.

JNO. K. J. FOSTER.

This is the specification referred to in the annexed Letters of Rrgistration granted to John Kissack Joshua Foster, this eighth day of August, A.D. 1883.

AUGUSTUS LOFTUS.

---

**REPORT.**

---

Sir,

In reply to your B C. minute of the 8th instant, forwarding the application of Mr. John K. J. Foster for an invention entitled "Improvements in Extinguishing Fires, and in Apparatus to be used therein," we are of opinion that Letters of Registration might be issued for the protection of such invention.

Sydney, 25 June, 1883.

We have, &c.,

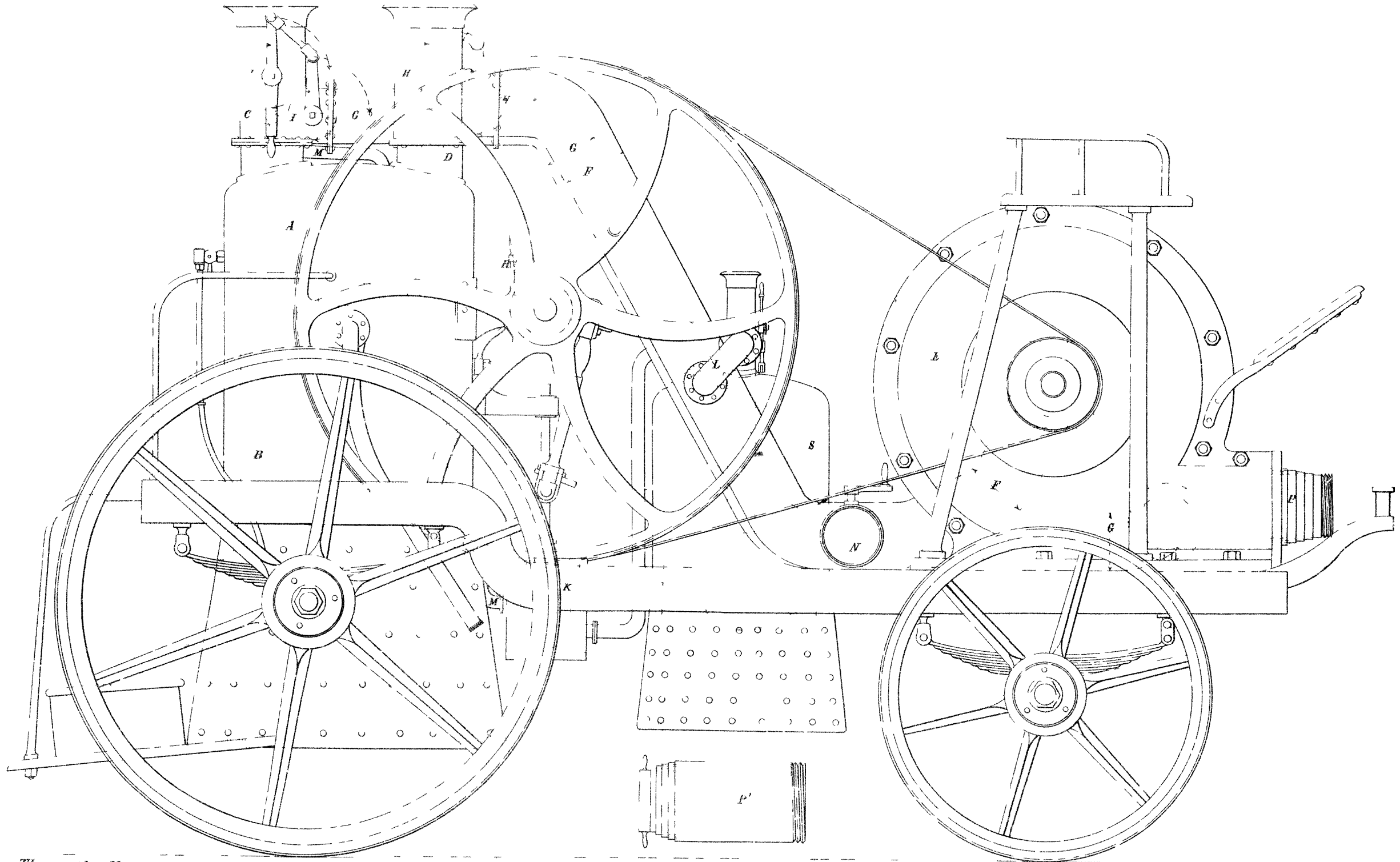
JAMES BARNET.

WILLIAM C. BENNETT.

The Under Secretary of Justice.

---

Drawings—one sheet.



*This is the Sheet of Drawings referred to in the annexed  
Letters or Registration granted to John Kissaek Joshua  
Foster, this eighth day of August A D 1883*

*Augustus Loftus*



A.D. 1883, 8th August. No. 1292.

IMPROVEMENTS IN OR RELATING TO APPARATUS FOR THE GENERATION,  
DISTRIBUTION, AND UTILIZATION OF ELECTRICAL ENERGY.

LETTERS OF REGISTRATION to Thomas Alva Edison, for Improvements in  
or relating to Apparatus for the Generation, Distribution, and Utilization of  
Electrical Energy.

[Registered on the 10th day of August, 1883, in pursuance of the Act 16 Vic. No 24.]

BY HIS EXCELLENCY THE RIGHT HONORABLE SIR AUGUSTUS WILLIAM FREDERICK SPENCER LOFTUS  
(commonly called LORD AUGUSTUS LOFTUS), Knight Grand Cross of the Most Honorable Order of the  
Bath, a Member of Her Majesty's Most Honorable Privy Council, Governor and Commander-in-Chief  
of the Colony of New South Wales and its Dependencies.

TO ALL TO WHOM THESE PRESENTS SHALL COME, greeting :

WHEREAS THOMAS ALVA EDISON, of Menlo Park, New Jersey, United States of America, hath by  
his Petition humbly represented to me that he is the author or designer of a certain invention or improve-  
ment in manufactures, that is to say, of an invention entitled "Improvements in or relating to Apparatus  
for the Generation, Distribution, and Utilization of Electrical Energy," which is more particularly described  
in the specification and the sheet of drawings which are hereunto annexed ; and that he, the said Petitioner,  
hath deposited with the Honorable the Treasurer of the said Colony of New South Wales the sum of  
Twenty Pounds sterling, for defraying the expense of granting these Letters of Registration, as required by  
the Act of Council, sixteenth Victoria, number twenty-four ; and hath humbly prayed that I would be  
pleased to grant Letters of Registration, whereby the exclusive enjoyment and advantage of the said inven-  
tion or improvement might be secured to him for a period of fourteen years : And I, being willing to give  
encouragement to all inventions and improvements in the arts and manufactures which may be for the public  
good, and having received a report favourable to the prayer of the said Petition from competent persons  
appointed by me to examine and consider the matters stated therein and to report thereon for my information,  
am pleased, with the advice of the Executive Council, and in exercise of the power and authority given to  
me by the said Act of Council, to grant, and do by these Letters of Registration grant, unto the said Thomas  
Alva Edison, his executors, administrators, and assigns, the exclusive enjoyment and advantage of the said  
invention or improvement, for and during the term of fourteen years from the date hereof ; to have, hold,  
and exercise unto the said Thomas Alva Edison, his executors, administrators, and assigns, the exclusive  
enjoyment and advantage thereof, for and during and unto the full end and term of fourteen years from the  
date of these presents next and immediately ensuing, and fully to be complete and ended : Provided always,  
that if the said Thomas Alva Edison shall not, within three days after the granting of these Letters of  
Registration, register the same in the proper office in the Supreme Court, at Sydney, in the said Colony  
of New South Wales, then these Letters of Registration, and all advantages whatsoever hereby granted,  
shall cease and become void.

In witness whereof, I have hereunto set my sign manual, and have caused the present Letters of  
Registration to be sealed with the seal of the said Colony of New South Wales, at Govern-  
ment House, Sydney, in New South Wales, this eighth day of August, in the year of our  
Lord one thousand eight hundred and eighty-three.

[L.S.]

AUGUSTUS LOFTUS.

*Apparatus for the Generation, Distribution, and Utilization of Electrical Energy.*

SPECIFICATION of THOMAS ALVA EDISON, of Menlo Park, New Jersey, United States of America, Electrician, for an invention entitled "Improvements in or relating to Apparatus for the Generation, Distribution, and Utilization of Electrical Energy."

IN the generation of electrical energy for light, power, and other purposes, I employ a dynamo-electric machine having current collectors of a peculiar construction and arrangement, as hereinafter described, whereby the capacity of the machine is largely increased, I also apply the same improvements to electro-dynamic motors.

In the working of continuous current dynamo-electric machines, or electro-dynamic motors, the increase of the load of such machines causes the neutral line to advance in the direction of rotation away from the line of maximum electro-motive force or work. It has been found necessary heretofore to shift the commutator brushes or current collectors forward to the neutral line, in order to prevent destructive sparks; but the removal of the brushes away from the line of maximum electro-motive force of a generator reduces the electro-motive force of the machine. With electro-dynamic motors the difficulties are greatly increased, since the load may vary frequently, and if the brushes are adjusted for the average load, the shifting of the neutral line away from the brushes will be productive of undue sparking, destructive both of the commutator and the brushes.

Now this invention has partly for its object the production of means whereby the current collectors or commutator brushes may be retained at the points of maximum, electro-motive force, or work of the generator or motor, without undue or destructive sparking, the capacity of the machines being thereby largely increased.

It has been the universal practice heretofore to use for the commutator brushes of machines of this character, copper or other metal having good electrical conductivity and making good electrical contact. It has, however, been discovered that the copper brushes, by reason of their great conductivity and good contact, form circuits of very low resistance between the bars of the commutator as they pass over them, and hence short circuit in succession, the coils connecting the pairs of commutator bars, such coils then forming a local dynamo and generating a powerful local current; the breaking of that short circuit, which takes place when the brushes leave a commutator bar, causes the destructive spark. The generation of the powerful local currents also causes the heating of the machine and the loss of energy due to such heating.

According to this invention the current collectors are made of a material of inferior electrical conductivity and contact compared with copper, and are otherwise so constructed and arranged that the bridge formed by each collector across the commutator bars has a large resistance compared with the local coils, the circuit of which is completed within the machine by the bridging of the commutator bars; hence the local current is very weak, and the spark reduced to comparatively nil. It is then possible to keep the collectors at the points of maximum electro-motive force or work, notwithstanding these may not be the neutral points, and by providing a number of such collectors the requisite total conductivity and contact can be obtained to carry the main current without sparking.

This part of my invention is illustrated in Figures 1 to 6 of the drawings.

Figure 1 illustrates a part of a dynamo-electric machine or electro-dynamic motor, with commutator brushes arranged in accordance with this invention.

Figure 2 is a view of the commutator, showing several brushes.

Figure 3, a view on a larger scale of two bars of a commutator and the improved brush.

Figure 4, a cross section of the brush.

Figure 5, an illustration of the course taken by the local current through the electrically divided brush; and

Figure 6, an illustration, showing the course of the local and main currents.

P, N (Figure 1) are the polar extensions of the field magnet of the generator or motor, A being the armature, B the commutator cylinder, and C C the commutator brushes. The varying neutral line on the commutator cylinder is represented by the dotted line *xx*, and the line of maximum electro-motive force by the dotted line *yy*. Heretofore, in order to prevent sparking, it has been found necessary to shift the brushes on to the line *xx*, but it is possible by reason of the peculiar construction and arrangement of the current collectors, according to the present invention, to keep them on line *yy* without sparking. Two or more commutator brushes connected together are used on each side of the commutator cylinder to carry the current, as shown in Figure 2. Each brush is constructed of layers of wires, *a*, of some metal or alloy, having inferior conductivity and making inferior contact compared with copper, and preferably having a high melting point. Nickel, iron, steel, cobalt, platinum, or palladium may be used, or alloys, such, for example, as phosphor-bronze or brass, but it is preferred to use German silver for the purpose, for the reason that it offers very great resistance and does not lose its stiffness by heat, as is the case with most alloys. The layers of wire *a* are by preference divided by metal plates or strips *b*, as shown.

The wires *a* or the wires *a* and plates *b* are formed into a solid mass by soldering at the outer end *c* of the brush. The plates *b* when employed may be japanned, as are also the wires *a*, so as to insure a good electrical division of the brush. The separating japanned metal plates may also be replaced by strips of mica or other suitable insulating material, but the japanned metal is preferred.

The brush rests with the ends of all its wires bearing on the commutator cylinder, as shown.

The course of the local current is indicated by the arrows in Figure 5, and by the smaller arrows in Figure 6, while the course of the main current is indicated by the large arrows in Figure 6.

The local coil *d* (Figure 6) has its circuit closed at the commutator by the bridge formed by the brush. This bridge, however, is of high resistance compared with the coil *d*. It is made so by the inferior electrical contact of the brush on the commutator, by the inferior conductivity of the metal of which the brush is made, and also by the electrical division of the brush at its inner or bearing end.

It will be noticed that the local current in addition to being forced to overcome the resistance offered by the length of the wires, has to overcome the main current in one side of the bridge formed by the brush.

The bars *e* of the commutator B may also be made of or surfaced with German silver or other suitable

*Apparatus for the Generation, Distribution, and Utilization of Electrical Energy.*

suitable alloy or metal, making inferior electrical contact compared with copper. This increases the resistance of the contact and makes the bridges formed by the brushes of higher resistance.

In addition to the local sparking there is the sparking due to the taking off of the main current, which (other things being equal) would necessarily be increased by the inferior contact made by the current collectors, but by augmenting the number of collectors, or the component parts of the collectors, to the requisite extent, the spark due to the main current may be reduced to the minimum by division.

The invention is applicable with the use of current collectors of other forms than brushes, as, for example, of plate springs, as will be well understood.

In the distribution of electrical energy for light, power, and other purposes, I provide a system in which currents of high tension can be used, whilst at the same time each translating device is rendered entirely independent of all the others. I am thus enabled to diminish the size of the conductors which convey the current, economizing in metal and allowing the conductors to be placed overhead instead of laid underground in places where the former arrangement is more desirable or convenient.

This result is accomplished by employing a source of energy of high electro-motive force, arranging the translating devices in multiple series, dividing the said source into as many parts as there are translating devices in series in any circuit which extend across between the main conductors, and correspondingly dividing each series of translating devices, such division being made by means of a central compensating conductor or conductors connected between the parts or divisions of the source of energy, and also between the translating devices, so that when all the devices in any multiple arc circuit are in use, current will pass through all such devices, the current passing across from the positive to the negative main conductors, but if one or more translating devices are removed from any series circuit the excess of current which would otherwise affect the other lamps in the circuit is taken by the compensating central conductor, so that the other translating devices remain unchanged. The compensating conductor is preferably a metallic wire, but the earth may be used for the purpose if desired.

In carrying out the system the central station or source of electrical supply may contain one, two, or any desired number of generators, according to the number of translating devices to be supplied with current, such generators developing a high electro-motive force, and being connected in any suitable manner.

Figure 7 illustrates the use of two dynamo or magneto-electric machines placed in series.

A, A represent the machines connected in series by conductor 3, and having positive and negative main conductors P, N, respectively extending from them. Midway between the generators the compensating conductor 4 is attached to conductor 3. Multiple arc circuits 5, 6, extend from the compensating conductor to each of the main conductors, and each of such multiple arc circuits contains a lamp or other translating device, those on one side of the compensating conductor being designated by  $a$ , and those on the other side by  $a'$ .

When, as shown, the number of lamps  $a$  is equal to that of lamps  $a'$ , any current which may tend to return through conductor 4 will be neutralized by the current which will meet it from wire 3, so that no current will pass in either direction in the said conductor 4; but if a lamp or lamps  $a'$  be removed from circuit, so that less current will pass from conductor P to conductor 4, the tendency from wire 3 to wire 4 will be correspondingly greater than the return tendency, and current due to the inequality will flow in wire 4, which will pass through the lamps  $a$  and return through conductor N; whilst if a lamp or lamps  $a$  be removed, so that less current will pass from 4 to N, the difference of current will return through conductor 4. Thus the conductor 4 compensates for differences in either side; and while the lamps are independently controllable, and any lamp can be removed from circuit without varying the current flowing to the lamps on the opposite side, yet it is evident that currents may be employed of as high tension as though the lamps were arranged in multiple series in the ordinary way.

When the lamps and conductors are properly located, so that at no time can there be a very great inequality between the two sets of lamps, the compensating conductor may be of small mass, it never being required to convey much current.

It is evident that more than one generator may be placed on each side of the compensating conductor in series or in multiple arc if desired.

The arrangement shown in Figure 8 is similar to that hereinbefore described with reference to Figure 7, except that here the lamps  $a$  and  $a'$  are placed across multiple arc circuits 7, 8, derived from the main conductors P, N. The same effect of course is produced as just described. The adjustable resistances R, R are shown in this Figure, which are used to compensate for differences in the drop in electro-motive force of the two conductors.

In lighting a building having a large number of lamps, one of the circuits 7, 8, projecting to the right, and one projecting to the left on the drawing, are run into the building, and the lamps divided between the two circuits. As the lamps are thus divided between opposite sides of the compensating conductor the turning on or off of the lamps of the building will not disturb the balance existing in the system. For the same reason large motors may be placed in cross circuits, between the main conductors P, N, without connection with the compensating conductor.

In Figure 9, three generators, A, A, A, are shown in series, there being two compensating conductors 4 and 4', and three sets of lamps  $a$ ,  $a'$ ,  $a''$ , the main portion of the current passing entirely across from conductor P to conductor N, and an amount due to differences in the number of translating devices will return through the central conductors.

The number of lamps  $a''$  being greater than  $a'$ , a portion of current due to the difference will return through conductor 4', the remainder passing through lamps  $a'$  to conductor 4.

The number of lamps  $a$  being greater than  $a'$ , current will flow from the generators through conductor 4 to supply lamps  $a$ , which current will return through main conductor N.

In Figure 10, C and C' each represents a district to be supplied with electrical energy, a central station or source of supply being provided for each district. At one central station generators B, B, are placed in multiple arc, and at the other central station generators B', B' are similarly arranged. It is desired to connect lamps in district C in series with lamps in district C'. In order to accomplish this a conductor D is run from one station to the other, connecting one pole of each battery of generators together.

*Apparatus for the Generation, Distribution, and Utilization of Electrical Energy.*

together. From the other poles run the feeding circuits  $P^1, N^1$  and  $P^2, N^2$ , such feeding circuits being connected with the main conductors of the system. Compensating conductors 4 are connected at convenient points to the said main conductors, all such compensating conductors being connected at the same point to the wire D, between the stations, so that a divided source of electrical energy is formed, as in the previous cases.

Current flows through feeding conductors  $P^1, P^2$  to main conductors  $p, p$ , then through cross circuits containing translating devices to main conductors  $n, n$ , thence by a conductor  $o$  to district  $C^1$ , through translating devices to main conductors  $p$ , and back to the generators by feeders  $N^1, N^2$ .

It is evident that each translating device in district C is in series with one in district  $C^1$ , though all such devices are independently controllable, the conductors 4 acting to compensate for the removal of any device on either side.

It is obvious that any desired number of districts may be connected in this manner, by proportionately dividing the source of energy, so that currents of very high electro-motive force may be employed.

Figure 11 illustrates the application of the invention to a single generator A of high electro-motive force.

The main current is taken from the machine by the commutator brushes C, C, to which are connected the main conductors P, N, and an extra brush  $C^1$  is provided between the main brushes, from which runs the compensating conductor 4. Lamps, motors, or other translating devices  $a$  are arranged, as in Figure 7.

The current taken by the extra brush neutralizes the tendency for current to return on the compensating wire, so that no current traverses that wire so long as the number of translating devices remain the same on each side of the said compensating wire, whilst as the numbers vary, current traverses such conductors in one or the other direction, as previously explained. It is evident that the generator may be still further divided by the use of a greater number of extra brushes and compensating conductors.

In Figure 12, D, D are secondary batteries, P, N, being the main conductors, and 4 the central conductor. R, R are the adjustable resistances for the purpose before described.

It is evident that with either of the forms described the adjustable resistances R, R may or may not be used, as found necessary.

Figure 13 illustrates the use of the earth as a compensating conductor, which arrangement may be convenient in some cases, though it is preferred to use a metallic conductor.

The generators A, A are connected by wire 3, in series and conductors P, N extend from them. Translating devices  $a^1$  are connected with conductor P and also to earth E, and translating devices  $a$  connected to conductor N are also connected to earth. Between the generators A, A wire 3 is connected to earth, as shown. It will readily be seen that current will pass through the earth from P to N, and thus through both sets of translating devices in multiple series. An amount of current, due to the inequality between the devices  $a$  and  $a^1$  will, it is evident, pass between wire 3, and the translating devices through the earth in the same manner as explained with reference to the metallic conductor 4, Figure 7.

In the utilization of electrical energy for lighting purposes, I employ an incandescing conductor formed as hereinafter described, so that it shall be of high resistance and of even resistance throughout its length, and have great flexibility.

The incandescing conductor consists of a number of fine continuous flexible carbon filaments massed together, so as to be in close contact throughout the whole length, and having their ends secured, the separate filaments being capable of independent expansion and contraction.

Figure 14 illustrates a portion of a carbon filament so constructed drawn to an exaggerated scale. In preparing the filament I take several long and very fine fibres of the same or almost the same length, such as those of Ramie flax and similar vegetable substances, and twist them tightly together, so as to form a fibrous thread;  $c, c$  (Figure 14) represent fibres so twisted and forming a fibrous thread or filament C. The ends are secured at  $a$ , preferably by a plastic carbonizable substance attached to them, such as a compound of carbon and sugar.

This filament thus formed is carbonized under strain or pressure or both, and may be bent either before or after carbonization into the desired form. The plastic compound upon the ends of the filament may form enlarged ends  $a$  for clamping. The ends of the twisted filament C are then attached to the leading-in-wires 1, 2 (Figure 15), sealed in the stem or tube B of a lamp, globe, or bulb A, and are preferably electroplated to such wires, the filaments before electroplating being again twisted tightly so as to bring them all in contact with each other throughout their entire length.

In lieu of the process described the filaments may be carbonized straight and separately, and such carbonized filaments be then twisted tightly together. The ends are then attached to the leading-in wires preferably by electroplating, the filaments being kept tightly twisted during this process.

The filament formed in either of the above ways and attached to the leading-in-wires is placed in the globe or bulb A of a lamp in the usual manner, and is ready for the exhausting process. Filaments may, it is evident, be braided or otherwise intertwined instead of twisted together.

Filaments formed as described are of unusually even resistance and incandescence, as each of the separate filaments is continuous, extending the whole length of the filament. The filament is also exceedingly flexible and elastic, and therefore well adapted for the purpose for which it is to be used.

This flexibility arises from the fact that the carbon filament is formed of a number of separate fine filaments, which are capable of independent contraction and expansion. This fact also makes the filament less liable to fracture from unequal expansion and contraction, which must occur with a carbon filament made as a single mass, since it is not possible to produce a filament of this latter character which will be absolutely homogeneous. In order to preserve the independent character of the fine filaments, of which the complete filament is made up, it is essential that no carbonizable material should be placed upon the body of the carbon filament, nor should the carbon filament or the material from which it is made by carbonization be so treated as to cause the fine filaments to cohere.

In carbonizing these filaments the mould illustrated in Figures 16 and 17 may be advantageously employed.

It consists of a box B, formed of carbon, nickel, or other material capable of withstanding high temperatures. In one end is formed a slot  $b$ , of such size and shape as to receive the enlarged end of the filament.



*Apparatus for the Generation, Distribution, and Utilization of Electrical Energy.*

At the other end of the mould is set a movable block C provided with a slot *c*, similar to slot *b*. The block C may be of carbon, or of nickel, or of nickel covered with carbon; it must, however, have sufficient weight to keep the filament stretched.

The slots *b*, *c* do not extend quite to the bottom of the mould, and the filament for carbonization is placed in the mould from above with its ends resting in the bottoms of the slots, and its body kept out of contact with the mould. The filament is kept taut in the mould, which is in the carbonizing furnace, a suitable cover being provided. As the filament contracts the movable block C slides toward the centre of the mould, keeping the filament still tightly stretched, and preventing the fibres from untwisting.

It is evident that two movable blocks, instead of one, may be employed, the same sliding towards each other as the carbon contracts.

It is also obvious that the mould described can be used for any straight filaments, to allow contraction during carbonization. Filaments formed in this manner are preferably bent into a loop before being placed in the lamp.

Any desired number of filaments may of course be placed one above another in the carbonizing mould.

In order to prevent the rapid deterioration of the carbon filaments of incandescing electric lamps, and the obscuration of the glass globe or bulb by deposit due to electrical carrying between the filament and the globe or bulb, or the metallic terminals of the filament within the lamp, and thus to increase the length of life of the lamp, I employ an inert gas, which is contained in the globe or bulb at a suitably low determined pressure, as hereinafter fully described.

It has been found that the amount of deposit in any given period depends generally upon the degree of incandescence per unit surface to which the carbon filament is raised, the higher the degree of incandescence the more rapid being the deposit; it also depends upon the state of the vacuum, the higher the vacuum the greater being the deposit.

This deposit, it has been discovered, is due to electrical carrying of the carbon of the filament, the phenomenon being similar to that which takes place in the well-known Geissler tubes, wherein at certain stages of the vacuum or pressure, electrical carrying of the platina forming the terminal takes place, blackening the walls of the glass vacuum chamber, notwithstanding that the platina is scarcely above the temperature of the atmosphere, while at other stages of the vacuum or pressure this blackening does not take place. It has also been discovered that the economy of the carbon filament lamp (the number of standard lamp per horse power) increases as the pressure within the globe diminishes, up to a certain stage of the vacuum, when any higher exhaustion does not practically increase the economy. If the vacuum is diminished below this point of greatest economy to prevent electrical carrying, the economy of the lamp is diminished since the residual air acts as a carrier of heat to the walls of the chamber, where it is rapidly dissipated. But owing to the greatly diminished electrical carrying of the carbon from the filament, when the vacuum is low, it is possible to diminish the radiating surface, so as to raise each unit of surface to a higher degree of incandescence than would be practicable were the vacuum higher and the electrical carrying at its maximum; and as an increase in the degree of incandescence is an advance in the direction of economy, it is possible to regain by the economy of higher incandescence the energy lost by the increased convection of heat from the filament to the glass walls of the lamp, caused by the greater density of the residual gas due to a low vacuum.

Hence a carbon filament lamp, embodying these conditions of low vacuum and high incandescence and resistance, will have a longer life than if the vacuum were higher, and its candle power will not be diminished by the obscuration of the globe by a deposit of carbon; it will also permit of a reduction in the size of conductors, by reason of its increased resistance, and the filament itself will be more flexible and less liable to break.

For illustration it may be stated, that the radiating surface of the carbon filament can be reduced in size two-tenths, but the sizes of filaments used at present may be retained, the loss in economy being more than counterbalanced by the increased length of life.

The flexible carbon filament having been secured to the leading-in-wires, 1, 2, Figure 15, the lamp, globe, or bulb A is connected with a Sprengel pump D, Figure 15<sup>a</sup>, the mercury entering at *b* and passing out at *c*, and the globe or bulb is exhausted until a high vacuum is obtained, so as to remove all oxygen from the globe or bulb. During the latter part of the operation of exhausting the lamp, the flexible carbon filament may be gradually raised to an incandescence higher than that at which it is intended afterwards to be used; but this heating of the filament may be omitted.

After the exhaustion of the lamp, globe, or bulb is completed, an inert gas is allowed to pass into the globe or bulb, gradually reducing the vacuum and increasing the pressure within the globe or bulb.

The flexible carbon filament is raised to incandescence during the time that the inert gas is being admitted into the lamp, globe, or bulb, and certain phenomena will be noticed during this period. As the pressure gradually increases a light blue halo, very much spread out, will appear upon the positive clamp of the filament. As more gas passes in, the halo will increase in density and closely embrace the clamp; at this pressure carbon from the filament is deposited on the clamp in considerable quantity, which is due to the increase of the electrical resistance of the vacuum and the consequent prevention of deposit upon the globe or bulb. If now the pressure be further increased, the blue halo leaves the metallic portions of the clamp and appears on the carbon, at the junction of the latter and the metal of the clamp.

If now the pressure is carried beyond this point the blue halo will disappear entirely and the resistance of the residual gas will be so great as to nearly or quite extinguish the electrical carrying. The proper stage being reached the lamp is sealed off from the pump while incandescent.

The particular pressure at which the lamp should be sealed off is dependent upon the nature of the residual gas. With nitrogen for the inert gas, this pressure may be when a mercurial column (for measuring the amount of rarefaction) connected with the lamp stands at a height of about 20 inches, but with hydrochloric acid gas, on account of its greater electrical resistance, the pressure may be somewhat reduced.

At 29 inches with nitrogen and equivalent pressures with other gases the electrical carrying is greatly diminished. This vacuum of 29 inches or below that height for nitrogen, and equivalent pressures with other gases, is what is hereinafter termed a "low vacuum" or "low pressure."

Figures

*Apparatus for the Generation, Distribution, and Utilization of Electrical Energy.*

Figures 18, 19, and 20 represent the appearance of the blue halo on the positive clamp, at three stages. Figure 18, when it first appears, which corresponds with nitrogen for the inert gas to a pressure shown in the mercury column of  $30\frac{3}{8}$  inches; figure 19, when it becomes dense and closely embraces the clamp, which occurs at a pressure of  $29\frac{9}{16}$  inches; and figure 20, when it is about to disappear, which occurs at a pressure of  $28\frac{1}{8}$  inches.

Since the blue halo in the lamp disappears altogether to the eye when a certain pressure is reached, on account of the incandescence of the filament; and since the operation should be carried beyond this point, a Geissler spark-gauge E, figure 15<sup>a</sup>, connected with the exhaust tube of the pump, may be used to determine the exact point to seal off the lamp, the terminals of the Geissler spark-gauge being connected to an induction coil F, worked by a constant battery G. A mercurial column may be used for the purpose, but the Geissler spark-gauge is preferred, for the reason that the electrical carrying depends, where the vacuum is low, both upon the nature of the residual gas and the pressure, which conditions will also affect the Geissler spark-gauge, in which the phenomena due to electrical carrying can be observed after their disappearance to the eye in the lamp, while the mercurial column is only affected by the pressure.

Figures 21, 22, 23, 24, and 25 represent the phenomena of the spark-gauge. Figure 21 shows the sparks between the terminals at the atmospheric pressure; figure 22 shows a halo on the ends of the positive pole, which occurs at 20 inches on the mercury column; figures 23 and 24 show it extending along the wire, which occurs at about  $29\frac{3}{8}$  inches; and figure 25 shows the halo spread out so as to touch the walls of the tube, which occurs at  $30\frac{1}{4}$  inches of the mercury column; all these phenomena being observed with nitrogen for the inert gas.

The different degrees of exhaustion at which certain phenomena will appear in the spark-gauge, depend upon the size and distance apart of the electrodes, as well as on the chamber of the gauge and on the electro-motive force of the coil. Hence it is necessary to determine in the first instance, by the disappearance of the blue halo from the clamps of the filament due to increased pressure, the appearance of the spark-gauge at the exact moment when the lamp is to be sealed off, which is when an increased pressure is reached, equivalent to several inches of a column of mercury, after the disappearance of the halo from the metallic terminals of the filament.

It will be understood that it is best to diminish the pressure for the sake of economy, but not to the point where the blue halo begins to appear on the metallic terminals of the filament.

In introducing the inert gas, the exhaust tube may be connected with a reservoir of a pure inert gas, which can be allowed to pass as desired into the vacuum by means of a stop-cock, but by this method it is not practicable to properly manipulate the gas or make it free from oxygen. This difficulty is not experienced when the gas is evolved from a solid in a tube by the application of heat to the exterior of the tube; and the heat can be so applied as to set free the exact quantity of gas desired, the quantity being regulated with a nicety and exactness which cannot be obtained with a stop-cock. The method last referred to is therefore by preference employed, and is represented in the drawing, figure 15<sup>a</sup>.

H, is a chamber or tube connected with the exhaust tube of the pump. The tube H contains the solid material for producing the inert gas when the tube is heated. This material may be, for illustration, solid cyanide of mercury, which evolves cyanogen when heated. Other inert gases may, however, be used being evolved from the decomposition of different salts by heat. I, is a chamber or tube containing a drying agent.

In lieu of exhausting to a high vacuum with a mercury pump, and then gradually reducing the vacuum to the proper point by means of an inert gas, the lamp may be first exhausted to a high vacuum, and the inert gas then allowed to flow into the lamp, until the vacuum is reduced to atmospheric pressure, when the inert gas may be pumped out until the desired pressure is obtained, or any other method of displacing the oxygen by an inert gas and obtaining the desired pressure, may be employed.

The making of the inclosing chamber entirely of glass, through which the leading-in-wires are passed and in which they are sealed, and the hermetical closing of such glass inclosing chamber, assure the retention of the same conditions of pressure that it is found desirable to give the lamp when manufactured, which is a feature of essential importance in lamps with a low vacuum, as well as with lamps having a high vacuum. Since electrical carrying takes place also with incandescing conductors made of other material than carbon, this part of the invention is not limited to carbon, but is intended to include all flexible filamentary incandescing conductors, having, like carbon, a high specific resistance.

I claim as my invention—

First—The electrically divided current collector, made of a material having an inferior conductivity and making inferior contact compared with copper, in conjunction or not with commutator bars, constructed of or surfaced with a material making inferior contact compared with copper, substantially as hereinafter described.

Second—The employment in a system of distributing electrical energy for light, power, and other purposes of one or more compensating conductors, whereby translating devices arranged in multiple series are made independently controllable, substantially as hereinbefore described.

Third—The peculiar arrangements for the distribution of electrical energy, substantially as hereinbefore described, with reference respectively to figures 7, 8, 9, 10, 11, 12, and 13 of the accompanying drawing.

Fourth—The flexible carbon filament for an incandescing electric lamp, formed of a number of separate fine continuous filaments, substantially as hereinbefore described.

Fifth—The mould for the carbonization of straight filaments, substantially as hereinbefore described.

Sixth—An incandescing electric lamp, having in combination the following three elements, viz., a flexible filamentary conductor, of carbon, or other material having, like carbon, a high specific resistance; an inclosing chamber; and an inert gas, having a pressure sufficiently low to prevent electrical carrying of the material of the flexible filamentary conductor to the walls

*Apparatus for the Generation, Distribution, and Utilization of Electrical Energy.*

walls of the inclosing chamber, or the terminals of the filamentary conductor within the inclosing chamber, substantially as hereinbefore described.

Seventh—An incandescing electric lamp composed of a flexible filamentary conductor of carbon, or other material having, like carbon, a high specific resistance, a hermetically sealed inclosing chamber made entirely of glass, leading-in-wires passing through and sealed into the glass, and an inert gas, having a pressure sufficiently low to prevent electrical carrying of the material of the flexible filamentary conductor to the walls of the inclosing chamber, or the terminals of the filamentary conductor within the inclosing chamber, substantially as hereinbefore described.

In witness whereof, I, the said Thomas Alva Edison, have hereto set my hand and seal, this eighteenth day of May, 1883.

Witness—

W. S. BAYSTON, Law Clerk, Melbourne.

THOS. ALVA EDISON,  
(by his Agent, EDWD. WATERS).

This is the specification referred to in the annexed Letters of Registration granted to Thomas Alva Edison, this eighth day of August, A.D. 1883.

AUGUSTUS LOFTUS.

---

REPORT.

Sir,

We do ourselves the honor to report, in reply to your blank cover of the 23rd ultimo, No. 6,255, transmitting Mr. Thomas Alva Edison's Petition for the registration of an invention entitled, "Improvements in or relating to apparatus for the Generation, Distribution, and Utilization of Electrical Energy," that we are of opinion the prayer of the Petition may be granted in terms of Mr. Edison's specification, drawings, and claim.

The Under Secretary of Justice.

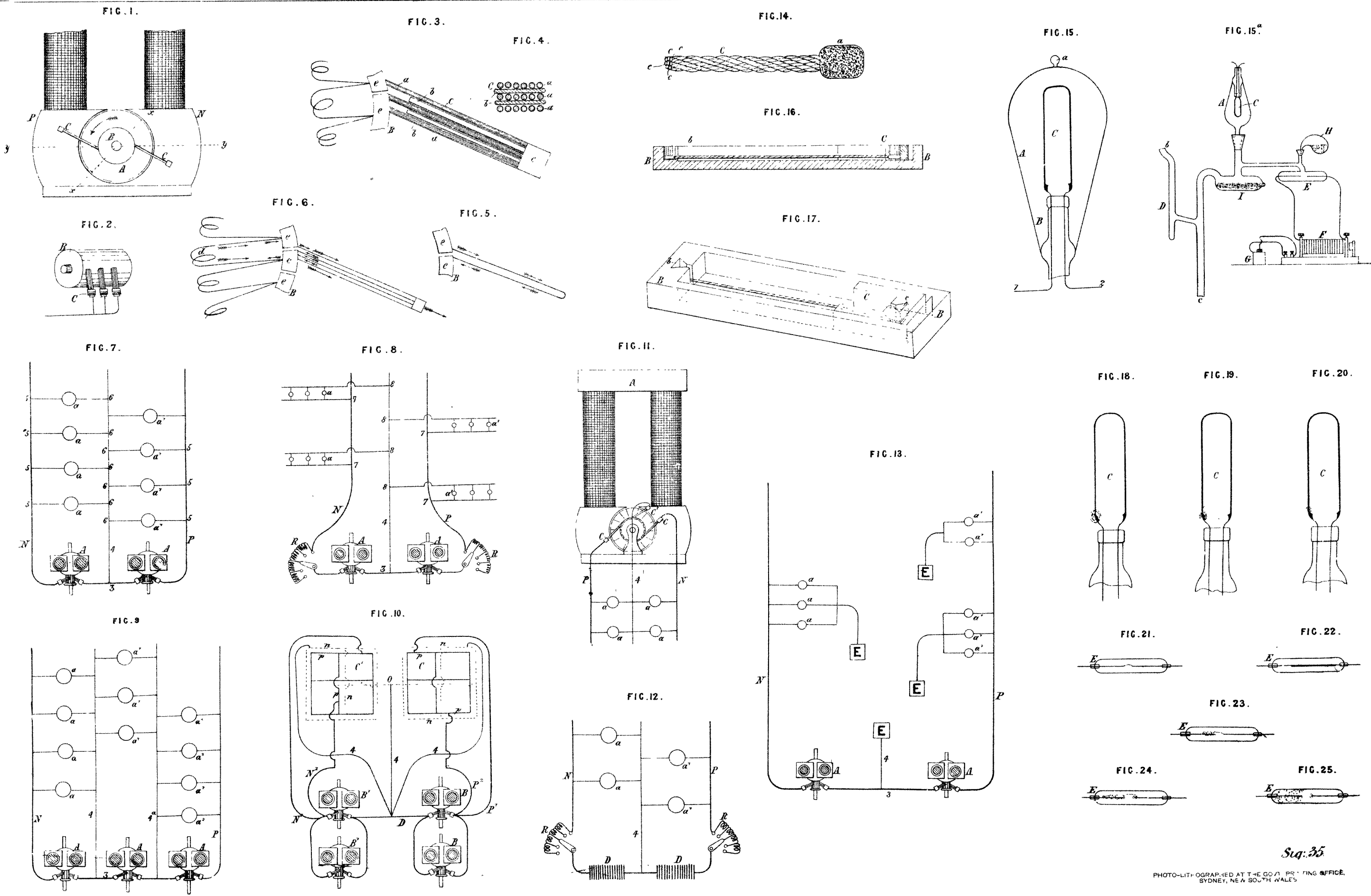
Sydney, 5 June, 1883.

We have, &c.,

E. C. CRACKNELL  
GOTHER K. MANN.

---

[Drawings—one sheet.]



This is the Sheet of Drawings referred to in the annexed Letters of Registration granted to Thomas Alva Edison, this eighth day of August A.D. 1883.  
 Augustus Loftus.



A.D. 1883, 14th August. No. 1293.

**IMPROVEMENTS IN APPARATUS FOR WASHING AND SEPARATING GOLD AND SILVER FROM THEIR ORES.**

**LETTERS OF REGISTRATION** to William John Tanner, for an invention entitled "Improvements in Apparatus for Washing and Separating Gold and Silver from their Ores."

[Registered on the 14th day of August, 1883, in pursuance of the Act 16 Vic. No. 24.]

BY HIS EXCELLENCY THE RIGHT HONORABLE SIR AUGUSTUS WILLIAM FREDERICK SPENCER LOFTUS (commonly called LORD AUGUSTUS LOFTUS), Knight Grand Cross of the Most Honorable Order of the Bath, a Member of Her Majesty's Most Honorable Privy Council, Governor and Commander-in-Chief of the Colony of New South Wales and its Dependencies.

TO ALL TO WHOM THESE PRESENTS SHALL COME, greeting :

WHEREAS WILLIAM JOHN TANNER, of London, in England, gentleman, hath by his Petition humbly represented to me that he is the author or designer of a certain invention or improvement in manufactures, that is to say, of an invention entitled "Improvements in Apparatus for Washing and Separating Gold and Silver from their Ores," which is more particularly described in the specification and sheet of drawings which are hereunto annexed; and that he, the said Petitioner, hath deposited with the Honorable the Treasurer of the said Colony of New South Wales the sum of Twenty Pounds sterling for defraying the expense of granting these Letters of Registration, as required by the Act of Council sixteenth Victoria, number twenty-four; and hath humbly prayed that I would be pleased to grant Letters of Registration, whereby the exclusive enjoyment and advantage of the said invention or improvement might be secured to him for a period of fourteen years: And I, being willing to give encouragement to all inventions and improvements in the arts or manufactures which may be for the public good, and having received a report favourable to the prayer of the said Petition from competent persons appointed by me to examine and consider the matters stated therein and to report thereon for my information, am pleased, with the advice of the Executive Council, and in exercise of the power and authority given to me by the said Act of Council, to grant, and do by these Letters of Registration grant unto the said William John Tanner, his executors, administrators, and assigns, the exclusive enjoyment and advantage of the said invention or improvement, for and during the term of fourteen years from the date hereof; to have, hold, and exercise unto the said William John Tanner, his executors, administrators, and assigns, the exclusive enjoyment and advantage thereof, for and during and unto the full end and term of fourteen years from the date of these presents next and immediately ensuing, and fully to be complete and ended: Provided always, that if the said William John Tanner shall not, within three days after the granting of these Letters of Registration, register the same in the proper office in the Supreme Court, at Sydney, in the said Colony of New South Wales, then these Letters of Registration, and all advantages whatsoever hereby granted, shall cease and become void.

In witness whereof, I have hereunto set my sign manual, and have caused the present Letters of Registration to be sealed with the seal of the said Colony of New South Wales, at Government House, Sydney, in New South Wales, this fourteenth day of August, in the year of our Lord one thousand eight hundred and eighty-three.

[L.S.]

AUGUSTUS LOFTUS.

*Improvements in Apparatus for Washing and Separating Gold and Silver from Ores.*

SPECIFICATION of WILLIAM JOHN TANNER, of London, England, gentleman, for an invention entitled "Improvements in Apparatus for Washing and Separating Gold and Silver from their Ores."

It is well known that in washing ores containing gold and silver in the ordinary manner some of the particles of the gold and silver sink by gravitation, and others float on the surface of the water.

It is also well known that certain metallic ores are repelled from the positive pole of an electric battery, and are attracted to the negative pole of the same.

Now, for washing and separating ores containing gold and silver over amalgam plates, according to my invention, I construct and arrange apparatus in such a manner that one of the amalgam plates is above or over the other, and the water containing the crushed ore passes between them, viz., over one plate and under the other; and if the surfaces of these plates, between which the water containing the metallic ore passes, be made amalgam plates, and both be brought into contact with the water, the lower plate will catch the heavy gold, and the upper plate the float gold which is on or near the surface of the water.

To amalgam plates I apply a current of electricity in the following manner:—In order to attract the float gold the upper plate is made an amalgam plate, its amalgamated face touching the water, and to such plate I attach the negative pole of a battery or other source of electricity, while I attach the positive pole of the said battery or other source of electricity to plates or strips of copper, or other suitable conductors of electricity. These plates or strips of copper are arranged in such a manner as to allow the water to pass over them, so that the electric current is maintained from the positive to the negative pole by means of the stratum of water; but the amalgam plate and the copper plate, strip, or the like, must never come into contact with each other, otherwise the operation would be destroyed.

To apply the electricity to an amalgam plate over which the water runs, the strips or plates of copper, or other suitable conductors of electricity, are placed over the amalgam plate. To this amalgam plate the negative pole of the battery or other source of electricity is attached, and to the strips or plates of copper the positive pole is attached, the electric current being maintained between the negative and positive poles by means of the stratum of water which is in contact with both the poles; but the amalgam plates must never come into contact with the strips or plates of copper or the like, for the reason as before stated.

My invention will be readily understood on reference to the accompanying drawings, which represent an apparatus constructed in accordance therewith.

Figure 1 is a longitudinal section of my improved apparatus.

Figure 2 a transverse section of a riffle or bath, on a larger scale.

Figure 3 shows, in fragmentary view, an arrangement for raising and lowering the copper plate (anode) shown in detached view in figure 4.

Figures 5 and 6 are sections showing the arrangement for raising and lowering the plates under which the water and ore pass, figure 5 being taken on the line *zz* of figure 6.

A is a hopper, in which the ground metallic ore is placed with the necessary amount of water. From this hopper the ore passes out at the spout B, and flows between the two amalgam plates C and D, the plate C being covered with amalgam on its lower face, and the plate D with amalgam on its upper face. The ore, after passing between these plates, falls upon or into a riffle or bath E, over which a plate of copper F is placed, and so arranged that the water and the ore contained therein pass through the riffle and under the copper plate. This plate is rendered adjustable by the means hereinafter described, so as to be capable of being raised or lowered in order to regulate the flow of the water. In the riffle or bath, at the bottom, I place a sheet of glass G, or some equally smooth surface, preferably a non-conductor of electricity, to prevent the loss of small particles of gold or silver amalgam, and on this sheet of glass I place copper bands, wires, or the like, H, which may be undulated, serrated, or coiled, in order to increase their surface. To these copper bands, wires, or the like, the negative pole of a battery or other source of electricity is attached, and to the copper plate F the positive pole is attached. After the ore has passed over or through the riffle, it passes over the plates or strips of copper or other suitable conductors of electricity J, and under the amalgam plate K, which is amalgamated on its lower face. To the strips or plates of copper J, I attach the positive pole of a battery or other source of electricity, and to the amalgam plate K, I attach the negative pole of such battery, the water containing the ore passing between and touching both the amalgam plate K and the strips or plates of copper J. I make the amalgam plate K adjustable, so as to regulate the flow of the water. The ore then passes over another amalgam plate L, and under strips or plates of copper M. To the amalgam plate L, I attach the negative pole of a battery or other source of electricity, and to the copper plates, strips, &c., M, I attach the positive pole of a battery or other source of electricity.

By this arrangement, in the first series the ore passes between two amalgam plates, and in the second series over or through a riffle, while in the third series it passes under an amalgam plate to which electricity is applied, in order to attract all the particles of light and float gold or silver which may be on or near the surface of the water, thus causing the amalgam plate to act like a magnet on such particles. The fourth series is the reverse of the third series, and is used to attract the heavier particles.

In order to regulate the flow of water, and to insure contact between the water and the plates of copper or the like, under which the water containing the metallic ore passes, I make such copper plates or the like adjustable in the following manner, and as shown in figures 2, 3, 4, and 5.

Figures 2 and 3 show a means of raising or lowering the copper plate F. The copper plate F is fastened to a backing *a* of wood or other suitable material, and at the two upper corners of this backing are fastened hangers *bb*, one at each end. These hangers drop into notches at the top of the bearings *cc*, one of which is placed at each side of the apparatus. These bearings *cc* are capable of being raised or lowered in the guides *dd*, and after being set at the required distance may be kept in their places by the set screws *ee*. The backing *a*, together with the copper plate F which is fastened to it, can be removed from the apparatus by the handle *f*.

Figures 5 and 6 show a means of raising or lowering the plates C, K, or M. *a* is a strip of wood or other material, having a ledge *b* on which the plates C, K, or M can be laid. This strip of wood *a* is fastened to a slotted piece of metal *c* which slides in a groove cut in the side of the framework of the apparatus

*Improvements in Apparatus for Washing and Separating Gold and Silver from Ores.*

apparatus, and can be raised or lowered, together with the plate which is laid thereon, to the required distance above the plates D, L, or J, and fixed in position by tightening the nut on the bolt *d*, which passes through the slot in the piece of metal, and through the side of the apparatus.

I wish it to be understood that I do not bind myself to any particular number of plates, bands, and riffles or baths, nor to apply them in combination or order as shown, as either of the series may be used separately; nor do I claim broadly the use of amalgam plates in apparatus for washing and separating gold and silver from their ores, as I am aware that amalgam plates have been used prior to the date of my invention; but what I do claim, and desire to secure by Letters Patent, is—

First—The general arrangement and combination of parts constituting the improved apparatus for use in the washing and separation of gold and silver from their ores, substantially as herein described, and as shown in the drawings.

Second—In apparatus constructed as herein described for use in washing and separating gold and silver from their ores, an amalgam plate, or amalgam plates, applied to the surface of the water containing the float gold or silver, as herein described, and for the purpose set forth.

Third—In apparatus constructed as herein described for use in washing and separating gold and silver from their ores, the application of electricity to an amalgam plate or amalgam plates, placed over the surface of the water containing float gold or silver, in the manner substantially as set forth.

Fourth—In apparatus constructed as herein described for use in washing and separating gold and silver from their ores, the application of electricity to an amalgam plate, or amalgam plates, over which the water containing gold or silver passes, in the manner substantially as set forth.

Fifth—The means, substantially as herein described, for adjusting the plates located on the top of, or on the surface of, the water.

In witness whereof, I, the said William John Tanner, have hereunto set my hand and seal, this eighteenth day of April, one thousand eight hundred and eighty-three.

W. J. TANNER.

This is the specification referred to in the annexed Letters of Registration granted to William John Tanner, this fourteenth day of August, A.D. 1883.

AUGUSTUS LOFTUS.

---

REPORTS.

Sir,

Sydney, 14 June, 1883.

The Petition of Mr. Wm. John Tanner for Letters of Registration for an invention entitled "Improvements in apparatus for Washing and Separating Gold and Silver from their Ores" having been referred to us, we have examined the specification and drawings accompanying the same, and have the honor to report thereon as follows:—

The Petitioner shows by his drawings an arrangement in which mercury is used in connection with a current of electricity. As this has been already granted to Mr. Richard Barker in January last, it cannot now form part of a claim.

If the drawings be altered in this respect, we may be able to recommend the issue of Letters of Registration for the other portions of the specification.

We have, &c.,

A. LEIBIUS.  
CHAS. WATT.

The Under Secretary of Justice.

Sir,

Sydney, 29 June, 1883.

We have the honor to return herewith the papers connected with an application of Mr. William Tanner for Letters of Registration for an invention entitled "Improvements in Apparatus for Washing and Separating Gold and Silver from their Ores," and to report that in their now amended form we see no objection to the issue of Letters of Registration, in accordance with drawings, specification, and claim.

We have, &c.,

A. LEIBIUS.  
CHAS. WATT.

The Under Secretary of Justice.

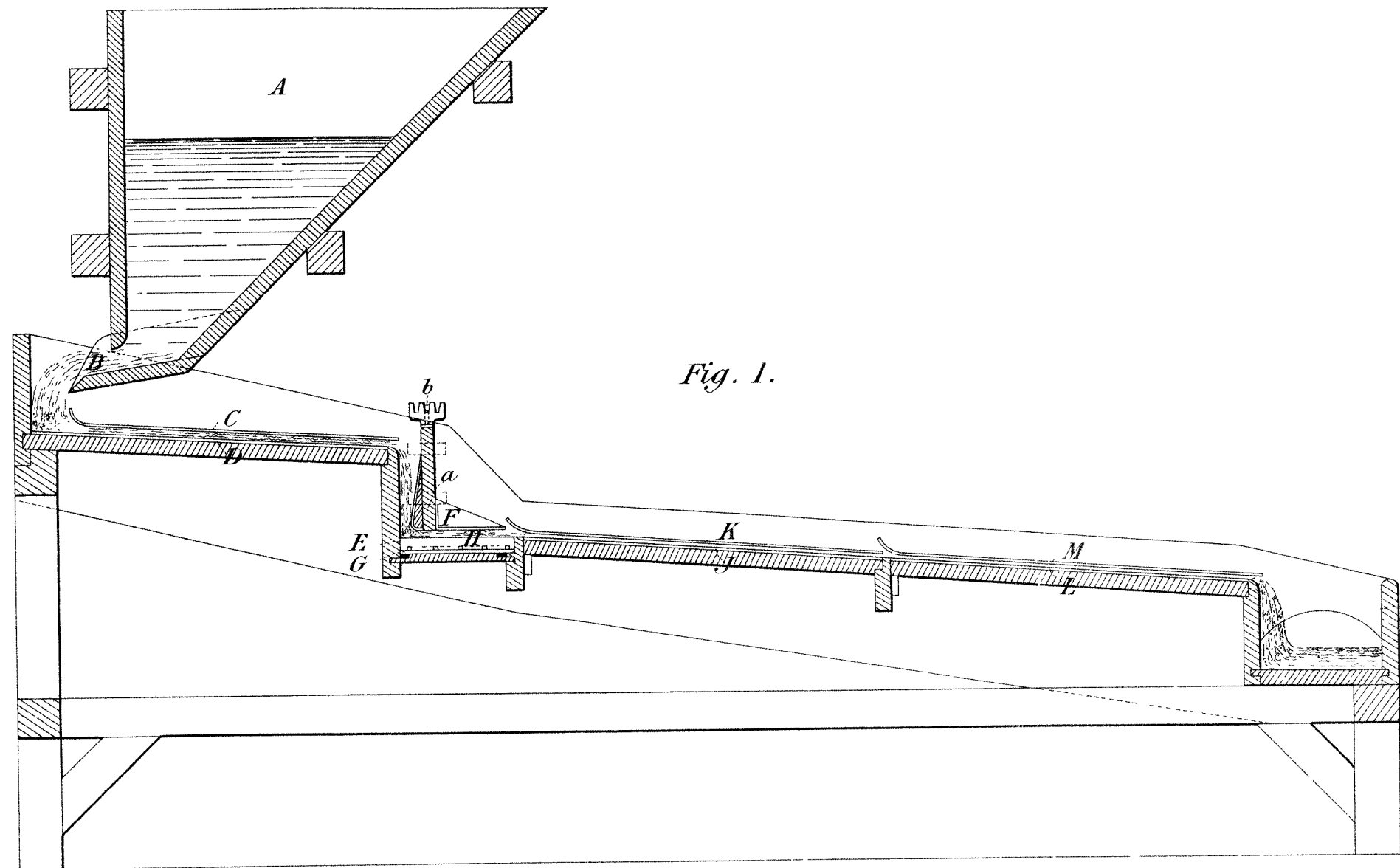


Fig. 1.

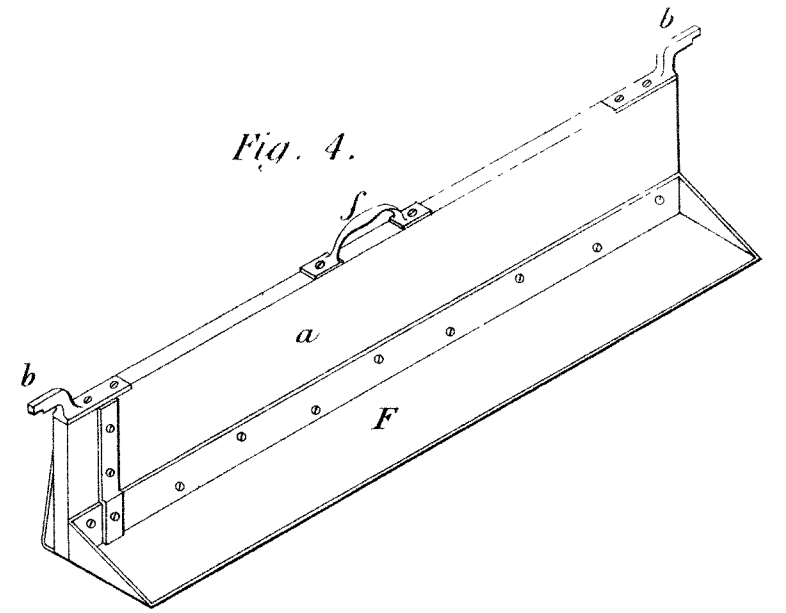


Fig. 4.

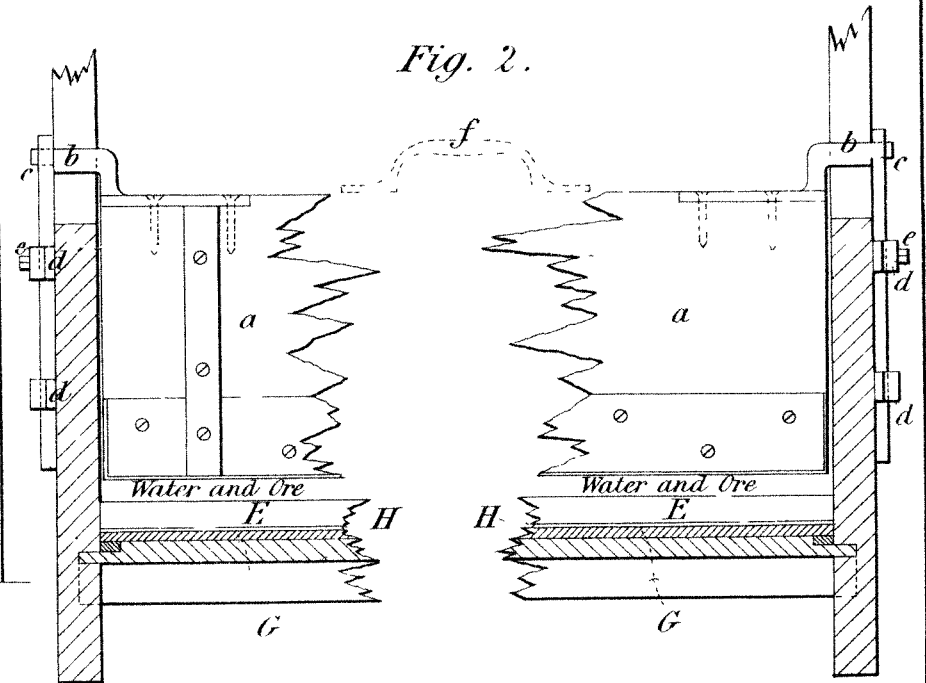


Fig. 2.

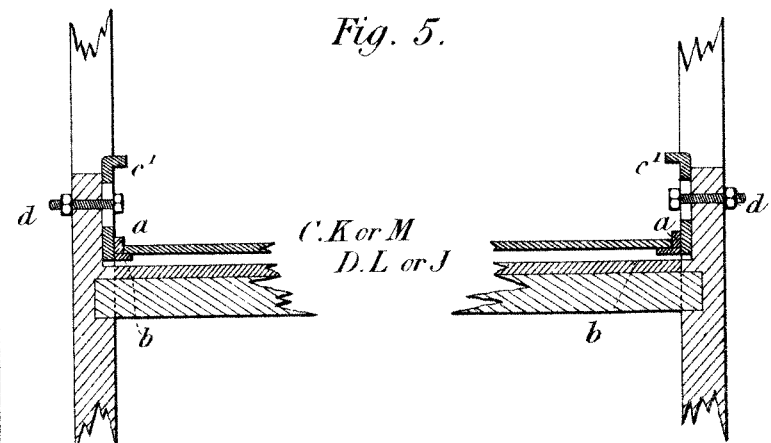


Fig. 5.

C, K or M  
D, L or J

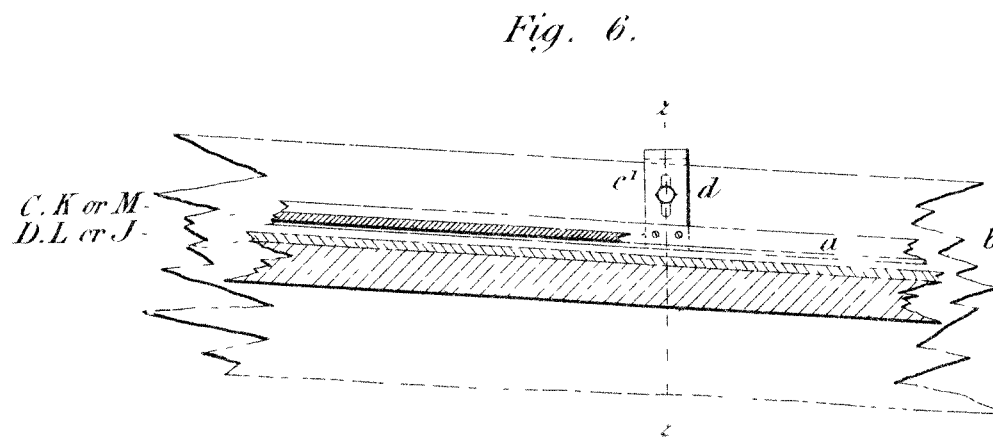


Fig. 6.

C, K or M  
D, L or J

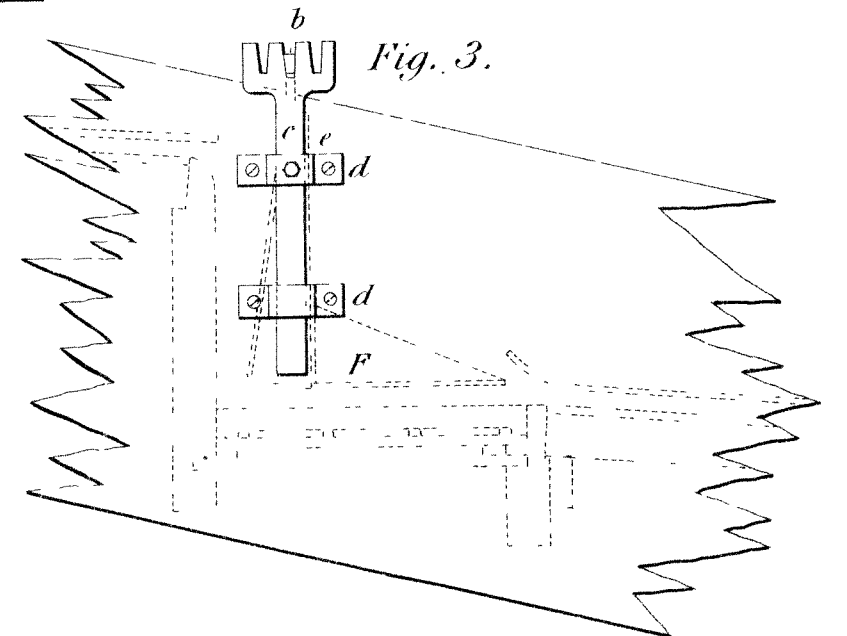


Fig. 3.

This is the Sheet of Drawings referred to in the annexed Letters of Registration granted to William John Tanner; this fourteenth day of August, A.D., 1883.  
Augustus Loftus.





A.D. 1883, 14th August. No. 1294.

**IMPROVEMENTS IN PICKING, CLEANING, AND BURRING WOOL AND SIMILAR MATERIAL, AND IN APPARATUS TO BE USED THEREFOR.**

LETTERS OF REGISTRATION to Auguste Frayssé, for Improvements in Picking, Cleaning, and Burring Wool and similar material, and in apparatus to be used therefor.

[Registered on the 14th day of August, 1883, in pursuance of the Act 16 Vic. No. 24.]

BY HIS EXCELLENCY THE RIGHT HONORABLE SIR AUGUSTUS WILLIAM FREDERICK SPENCER LOFTUS (commonly called LORD AUGUSTUS LOFTUS), Knight Grand Cross of the Most Honorable Order of the Bath, a Member of Her Majesty's Most Honorable Privy Council, Governor and Commander-in-Chief of the Colony of New South Wales and its Dependencies.

TO ALL TO WHOM THESE PRESENTS SHALL COME, greeting :

WHEREAS AUGUSTE FRAYSSE, of Antwerp, in the Kingdom of Belgium, hath by his Petition humbly represented to me that he is the author or designer of a certain invention or improvement in manufactures, that is to say, of an invention entitled "Improvements in picking, cleaning, and burring wool and similar material, and in apparatus to be used therefor," which is more particularly described in the specification hereto annexed marked A, and the two sheets of drawings marked B and C respectively and also hereunto annexed; and that he the said Petitioner hath deposited with the Honorable the Treasurer of the said Colony of New South Wales the sum of Twenty Pounds sterling, for defraying the expense of granting these Letters of Registration, as required by the Act of Council, sixteenth Victoria number twenty-four; and hath humbly prayed that I would be pleased to grant Letters of Registration, whereby the exclusive enjoyment and advantage of the said invention or improvement might be secured to him for a period of fourteen years: And I, being willing to give encouragement to all inventions and improvements in the arts or manufactures which may be for the public good, and having received a report favourable to the prayer of the said Petition, from competent persons appointed by me to examine and consider the matters stated therein and to report thereon for my information, am pleased, with the advice of the Executive Council, and in exercise of the power and authority given to me by the said Act of Council, to grant, and do by these Letters of Registration grant unto the said Auguste Frayssé, his executors, administrators, and assigns, the exclusive enjoyment and advantage of the said invention or improvement, for and during the term of fourteen years from the date hereof; to have, hold, and exercise unto the said Auguste Frayssé, his executors, administrators, and assigns, the exclusive enjoyment and advantage thereof, for and during and unto the full end and term of fourteen years from the date of these presents next and immediately ensuing, and fully to be complete and ended: Provided always, that if the said Auguste Frayssé shall not, within three days after the granting of these Letters of Registration, register the same in the proper office in the Supreme Court, at Sydney, in the said Colony of New South Wales, then these Letters of Registration, and all advantages whatsoever hereby granted, shall cease and become void.

In witness whereof, I have hereunto set my sign manual, and have caused the present Letters of Registration to be sealed with the seal of the said Colony of New South Wales, at Government House, Sydney, in New South Wales, this fourteenth day of August, in the year of our Lord one thousand eight hundred and eighty-three.

[L.S.]

AUGUSTUS LOFTUS.

*Improvements in Picking, Cleaning, and Burring Wool, &c.*

SPECIFICATION of AUGUSTE FRAYSSE, of Antwerp, in the Kingdom of Belgium, for "Improvements in picking, cleaning, and burring Wool, and similar material, and in apparatus to be used therefor."

THE object of this invention is to remove the burrs from wool by means of streams of water in conjunction with a special burring machine.

In the accompanying drawings, fig. 1 is a longitudinal elevation of the machine; fig. 2 is a plan view of the same; fig. 3 is a side view on a larger scale of the arrangement of a portion of the water-pipes and of the mechanism for operating them; and fig. 4 is a longitudinal section of fig. 3.

The machine is formed in two parts, marked respectively X and Z. The part X consists of a frame A, on which is mounted in suitable bearings a cylinder or drum, D, the whole surface of which is furnished with card or comb teeth or pins, set at an angle and arranged in order and at suitable distances from each other.

On the left of this cylinder, and in contact with its surface, are two feed rollers, CC<sup>1</sup>, mounted in suitable bearings on the frame, which seize the wool as it is delivered to them by an endless web, B, situated on the same side and carried by rollers mounted in bearings on the frame, and deliver it to the cylinder D.

At the point where the wool leaves the feed rollers CC<sup>1</sup>, and where it is received upon the pins or teeth of the cylinder, a stream of water under pressure is caused to fall upon the whole length of the said cylinder. This has the effect of pressing the wool between the pins or teeth while the burrs remain sticking on the points of the same. The stream of water issues from a longitudinal slit in a pipe, R, arranged at a suitable height above and parallel to the upper part of the cylinder D. A roller, S, covered with flexible copper wire or other metal points, and mounted in suitable bearings on the frame, is placed immediately above the pipe R and under the clearer E, and bears on the cylinder D. In order, in some measure, to remove the burrs from the teeth by means of its flexible wire points, the roller S should turn very slowly. To this end it is furnished at one end with a toothed wheel, s, which gears into a small pinion, s<sup>1</sup>, mounted on the end of the feed roller C<sup>1</sup>, by which motion is communicated to it. This may also be effected by an endless screw gear, or in any other convenient manner.

The burrs being thus partly disengaged from, but still adherent to, the teeth, are now easily swept off by the clearer E, which is mounted in a standard on the frame behind the roller S, and bears on the teeth of the comb cylinder D, which rotates in an opposite direction at great speed. If desirable, the number of water-pipes may be increased, or the number of the carding rollers may be increased, by a series of workers and clearers. On the right-hand side of the cylinder D a water-pipe, R<sup>1</sup>, arranged in a similar manner to the pipe R, delivers a stream of water tangentially on to the cylinder. This stream of water has the effect of disengaging the wool from the comb or card teeth, which is then stripped from the cylinder by a revolving brush or dropper, H, of suitable proportions mounted in bearings on the frame, and revolving at a high speed in or immediately over a bath O.

Movement is communicated to the cylinder D, in the direction of the arrow, and at any desired speed, by means of a band passing round a pulley J, mounted on the axle of the cylinder. A second pulley, J<sup>1</sup>, or chain wheel, fixed on the opposite end of the cylinder-axle, transmits rotary movement to a wheel, K, on the frame, which in its turn actuates the inner roller of the web or apron B. This roller is furnished with a pinion, I, which gears with the pinion I<sup>1</sup> of the roller C, which engages with the pinion I<sup>2</sup> of the roller C<sup>1</sup>, thus transmitting to these rollers, CC<sup>1</sup> respectively, rotary motion in the direction of the arrows.

The brush H is caused to rotate at a high speed by means of the wheel K<sup>1</sup>, which is actuated by a third pulley or chain wheel, J<sup>2</sup>, placed by the side of the cylinder D. The same wheel, K<sup>1</sup>, also gives motion to the clearer E.

It has been before remarked that the roller S is actuated by the feed roller C. The pinion L on the end of the machine may be actuated by the wheel K.

The wool, after being treated for the first time, is removed from the bath O on to the endless web b of a second apparatus, Z, which is a modification of the first, and serves for the final treatment of certain qualities of wool.

This apparatus Z is placed immediately behind (as in the present instance) or to the right or left of the first-described machine, and is constructed in the following manner:—d is a hollow cylinder, composed of two discs, carrying between them comb or heckle bars furnished with suitable comb teeth, which form the outer periphery of the cylinder, the bars being mounted so that the water may pass between them. Rotary motion is transmitted to the cylinder through a chain wheel, Z<sup>1</sup>, on its axle by means of a chain running over a similar wheel, L, mounted in bearings P on the frame A of the apparatus X.

A circular brush or clearer, n, having its axis in the same horizontal plan as that of the cylinder d, turns against the cylinder at high speed, which motion is communicated to it by a belt from the pulley K<sup>1</sup> of the first machine X.

Three feed rollers, c c<sup>1</sup> c<sup>11</sup>, which serve to conduct the wool from the web b, and distribute it as uniformly as possible on the cylinder d, are mounted in suitable bearings immediately above the cylinder, in such a manner that the two first, c and c<sup>1</sup>, placed one over the other, shall have their axes in the same vertical plan as the axis of the cylinder; the third, c<sup>11</sup>, is of the same diameter as the second, c<sup>1</sup>, and is placed at the side of it, and at the same distance from the centre of the cylinder d. Above the feed roller c<sup>11</sup>, and mounted in the same standard which carries the said roller, is the forward roller of the endless web v, the corresponding back roller being mounted in supplementary swan-neck brackets k<sup>1</sup>, fixed to the frame a.

On the axle of the third feed roller c<sup>11</sup> is fixed a chain pulley, e, to which rotary motion is communicated by a smaller and corresponding pulley on the axle of the cylinder d. The opposite end of this roller is furnished with a pinion f, which gears with another pinion, f<sup>1</sup>, of the same diameter fixed to the end of the roller c<sup>1</sup>, and gives motion thereto.

On

*Improvements in Picking, Cleaning, and Burring Wool, &c.*

On this roller  $c^1$  and close to the pinion  $f^1$  is mounted a second and smaller pinion,  $f^2$ , which gears with a large toothed wheel,  $g$ , placed on one end of the forward roller carrying the endless web; at the opposite end of this roller is fixed a toothed wheel,  $g^1$ , which gears with a pinion,  $g^1$ , mounted on the end of the feed roller  $c$ , which thus receives (as well as the others) rotary motion in the desired direction by the means above described.

On a bracket projecting from the standard K is mounted a small solid iron roller,  $c^4$ , which rotates loosely in its bearings; this is for the purpose of holding the wool down to the web, and to cause a slight strain to be put upon it by the feed roller  $c$ .

In the first-described machine, X, I use water-pipes provided with longitudinal slits, through which the stream of water is projected on to the wool, pressing it between the pins; but I may also employ pipes with transverse slits or incisions of about  $\frac{1}{2}$  centimetre in length, which are arranged at suitable distances apart. In this case, the water, instead of being projected in one stream, will be projected in as many transverse fan-shaped streams as there are incisions in the pipe (see figs. 3 and 4). The object of this arrangement is to bring a larger surface of the cylinder under the action of water under pressure in the direction of its motion, and in order that there shall be no portion of its surface which has not been fully brought under the action of water under pressure. A rapid reciprocating movement is communicated to the pipes with transverse incisions in such a manner that every portion of the surface of the cylinder will be brought successively under the pressure of each set of fan-shaped jets of water.

In the present example I employ for the second apparatus, Z, pipes with transverse incisions, which are arranged in the following manner:—The pipe  $r$ , which is used to press the wool between the pins on the comb or heckle bars, is placed in front of the feed rollers at a suitable height above and distance from the cylinder  $d$ , and is carried horizontally by two vertical or inclined supports,  $k^1$ , fixed to the frame in any convenient manner.

The pipe  $r^1$ , which serves to disengage the wool from the pins on the cylinder, is situated in the interior thereof, and traverses it longitudinally in the line of its axis, passing through the bearings of the same, which serve as guides for the pipe.

These parallel pipes,  $r$  and  $r^1$ , communicate with each other or are joined at their ends by means of a pipe,  $r^2$ , which is set at an angle determined by the position of the pipe  $r$ . To the pipe  $r^2$ , or extension of the same, is attached an india-rubber hose, which will be free to follow the movements of the assembled pipes,  $r$ ,  $r^1$ ,  $r^2$ . In order to give these latter the to-and-fro movement before mentioned, I mount on one end of the axle of the doffer  $h$  a worm,  $l$ , which gears into a worm-wheel,  $l^1$ , mounted on a rectangular frame,  $k^2$ , suitably secured to the frame  $a$ , the shaft  $m$  of the worm-wheel being at right angles to the inclination of the pipe  $r^2$ . This shaft projects beyond the rectangular frame  $k^2$ , at the side where the tubes are situated, and is furnished with a crank-arm,  $n$ , the pin of which is attached to a connecting link,  $o$ , fastened to the pipe  $r^2$ . The worm  $l$ , rotating at high a speed with the doffer  $h$ , transmits by means of the worm-wheel  $l^1$ , crank-arm  $n$ , and connecting link  $o$ , a to-and-fro or alternating horizontal movement to the pipes  $r$ ,  $r^1$ ,  $r^2$ .

If, instead of using pipes with transverse openings or incisions, it is desired to use pipes with a single longitudinal slit or opening to deliver a single stream of water which shall not constantly strike on the same place, it will be necessary to give the pipes an oscillatory movement. This may be effected by a similar arrangement of worm and worm-wheel mounted at right angles to the former one, and attached to the frame by supplementary brackets. In this case the crank-arm  $n$  would act on a connecting link so attached to the tube or tubes as to move them in the desired direction.

The action of the machine is as follows:—The wool carried by the endless web or apron B of the part X is gripped by the feed roller CC<sup>1</sup>, which deliver it to the pins of the cylinder D, between which it is pressed by the stream of water falling from the pipe R. The burrs, which by this operation are impaled on the points, are then loosened by the clearer S above mentioned, and swept off by the clearer E.

The stream of water falling from the pipe R<sup>1</sup> disengages the wool from the comb teeth or pins, and it is carried by the brush or doffer H (which rotates at a high velocity) into the cistern or bath O. From the cistern O the wool is conducted on to the endless web  $b$  of the second machine Z, which passes it to the feed rollers  $c$ ,  $c^1$ ,  $c^2$ , to be in turn fed by these rollers to the teeth of the cylinder  $d$ , where the water coming out of the pipe  $r$  passes it on to or between the pins, leaving whatever burrs there are remaining in the wool sticking to the points of the teeth. These burrs are then swept off by the clearer  $h$ , and the wool, under the action of the water coming from the internal central pipe  $r^1$ , is disengaged from the points by the pressure of the water, and falls completely burred into the cistern or bath  $p$ . It will be understood that these two machines, X and Z, though on the same principle, but of different mechanical construction, may be employed separately, that is to say, the wool may be treated on either one or the other, or on both combined, as above described.

Having now set forth the nature of my invention, and explained the manner of carrying the same into effect, I wish it to be understood that I claim—

- 1st—In a machine for burring wool, the combination of the endless web or apron B, the feed rollers CC<sup>1</sup>, the water-pipe R, the clearer S, the clearer E, the water-pipe R<sup>1</sup>, and the doffer H, with the cylinder D, all arranged and operating substantially as herein shown and described with reference to the part X of figures 1 and 2 of the drawings.
- 2nd—In a machine for burring wool, the arrangement of the pipes  $r$  and  $r^1$  with transverse incisions, or with a single longitudinal slit, the last-named pipe passing longitudinally through the hollow bearings of the cylinder  $d$ , the means for giving to these pipes a to-and-fro horizontally reciprocating or an oscillatory movement, and the arrangement of the feed rollers  $c$ ,  $c^1$ ,  $c^2$ ,  $c^3$ , all in combination with the cylinder  $d$ , substantially as herein shown and described with reference to part Z of figures 1, 2, 3, and 4 of the drawings.
- 3rd—The machine for burring wool, substantially as herein shown and described with reference to the part X of figures 1 and 2 of the drawings.

---

*Improvements in Picking, Cleaning and Burring Wool, &c.*

---

4th—The machine for burring wool, substantially as herein shown and described with reference to the part Z of figures 1, 2, 3, and 4 of the drawings.

In witness whereof, I have hereunto set my hand and seal, this twenty-second day of March, one thousand eight hundred and eighty-three.

AUGUSTE FRAYSSÉ.

Witness—

GUST. GHIEBUYCK,  
Solicitor, boulevard de Waterloo, 47, Bruxelles.

AUG. JORISSEN,  
Engineer, 83, rue Belliard, Bruxelles.

\_\_\_\_\_

This is the specification referred to in the annexed Letters of Registration granted to Auguste Frayssé, this fourteenth day of August, A.D. 1883.

AUGUSTUS LOFTUS.

---

REPORT.

---

Sir,

In reply to your B.C. minute of 18th June, forwarding application of Mr. Lavers for an invention by Auguste Frayssé, of Antwerp, entitled "Improvements in picking, cleaning, and burring Wool, and similar material, and an apparatus to be used therefor," we have to report that we see no reason why such letters should not be issued.

Sydney, 30 June, 1883.  
We, have, &c.,  
JAMES BARNET.  
WILLIAM C. BENNETT.

The Under Secretary of Justice.

---

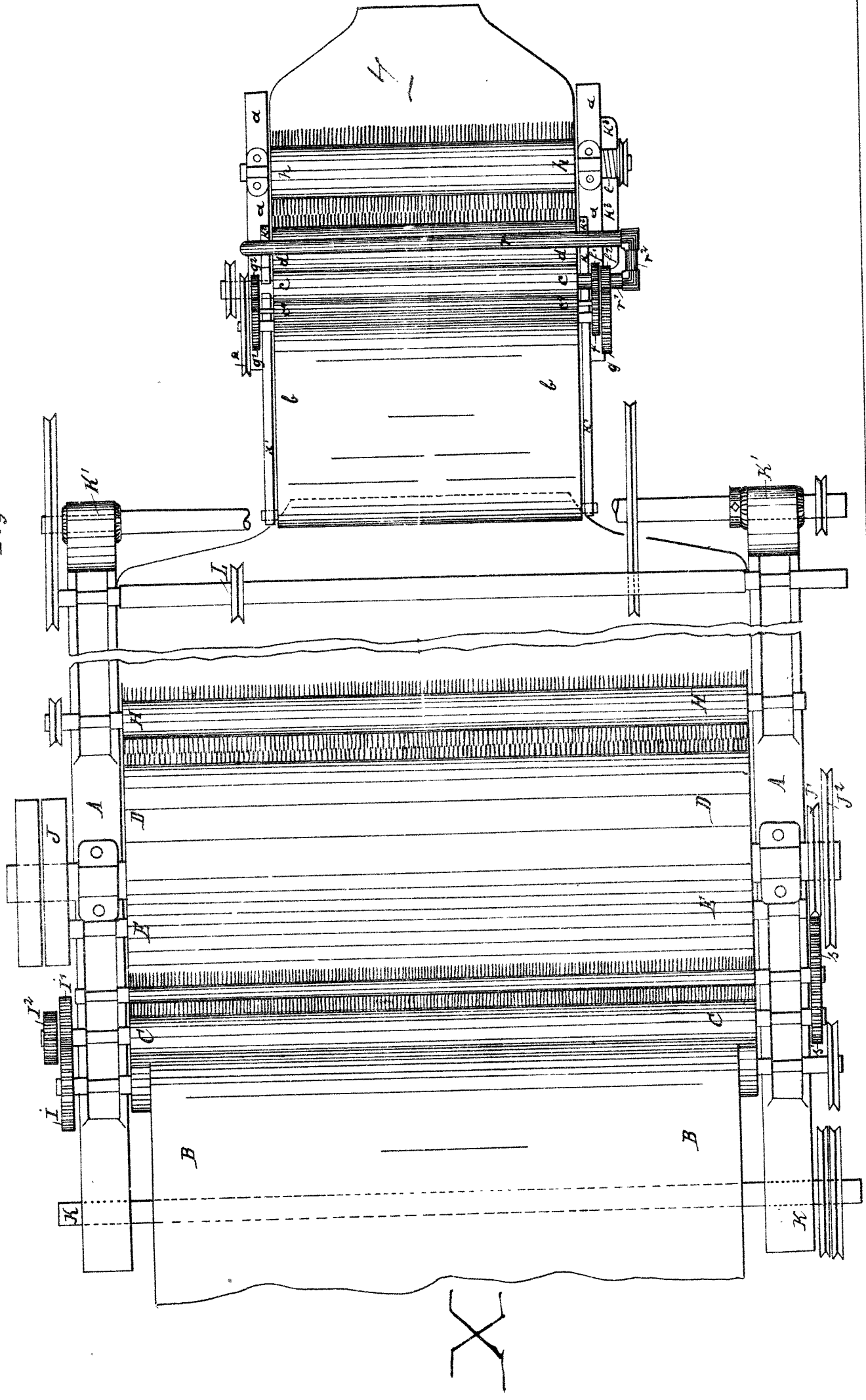
[Drawings—two sheets.]



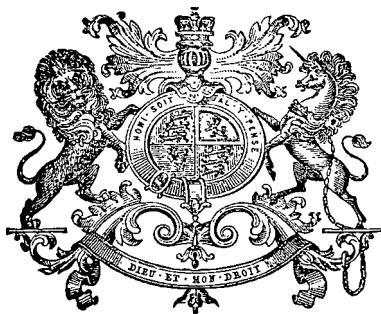
C.

1294.

Fig. 2.



This is the Sheet of Drawings marked C. referred to in the annexed  
 Letters of Registration granted to Auguste Frayssé this fourteenth  
 day of August A.D. 1885.  
 Augustus Loftus.  
 sig:35.



A.D. 1883, 14th August. No. 1295.

**IMPROVEMENTS IN IMPLEMENTS FOR SHEARING SHEEP, AND IN MACHINERY  
FOR DRIVING SAME.**

**LETTERS OF REGISTRATION to Joseph C. Wightman, for Improvements in  
Implements for Shearing Sheep, and in Machine for driving same.**

[Registered on the 14th day of August, 1883, in pursuance of the Act 16 Vic. No. 24.]

BY HIS EXCELLENCY THE RIGHT HONORABLE SIR AUGUSTUS WILLIAM FREDERICK SPENCER LOFTUS  
(commonly called LORD AUGUSTUS LOFTUS), Knight Grand Cross of the Most Honorable Order of  
the Bath, a Member of Her Majesty's Most Honorable Privy Council, Governor and Commander-in-  
Chief of the Colony of New South Wales and its Dependencies.

TO ALL TO WHOM THESE PRESENTS SHALL COME, greeting :

WHEREAS JOSEPH C. WIGHTMAN, of Boston, in the United States of America, hath by his Petition humbly represented to me that he is the author or designer of a certain invention or improvement in manufactures, that is to say, of an invention entitled "Improvements in Implements for Shearing Sheep, and in Machinery for driving same," which is more particularly described in the specification which is hereunto annexed marked A, and the two sheets of drawings marked B and C respectively, and which are also hereunto annexed ; and that he, the said Petitioner, hath deposited with the Honorable the Treasurer of the said Colony of New South Wales the sum of Twenty Pounds sterling, for defraying the expense of granting these Letters of Registration, as required by the Act of Council, sixteenth Victoria, number twenty-four ; and hath humbly prayed that I would be pleased to grant Letters of Registration, whereby the exclusive enjoyment and advantage of the said invention or improvement might be secured to him for a period of fourteen years : And I, being willing to give encouragement to all inventions and improvements in the arts or manufactures which may be for the public good, and having received a report favourable to the prayer of the said Petition, from competent persons appointed by me to examine and consider the matters stated therein and to report thereon for my information, am pleased, with the advice of the Executive Council, and in exercise of the power and authority given to me by the said Act of Council, to grant, and do by these Letters of Registration grant unto the said Joseph C. Wightman, his executors, administrators, and assigns, the exclusive enjoyment and advantage of the said invention or improvement for and during the term of fourteen years from the date hereof ; to have, hold, and exercise unto the said Joseph C. Wightman, his executors, administrators, and assigns, the exclusive enjoyment and advantage thereof for and during and unto the full end and term of fourteen years from the date of these presents next and immediately ensuing, and fully to be complete and ended : Provided always, that if the said Joseph C. Wightman shall not, within three days after the granting of these Letters of Registration, register the same in the proper office in the Supreme Court, at Sydney, in the said Colony of New South Wales, then these Letters of Registration, and all advantages whatsoever hereby granted, shall cease and become void.

In witness whereof; I have hereunto set my sign manual, and have caused the present Letters of Registration to be sealed with the seal of the said Colony of New South Wales, at Government House, Sydney, in New South Wales, this fourteenth day of August, in the year of our Lord one thousand eight hundred and eighty-three.

[L.S.]

AUGUSTUS LOFTUS.

*Improvements in Implements for Shearing Sheep, &c.*

SPECIFICATION of JOSEPH C. WIGHTMAN, of Boston, in the United States of America, for an invention entitled "Improvements in Implements for Shearing Sheep, and in Machinery for driving same."

THIS invention may be divided into two parts—first, to implements for shearing sheep, and second, to the machinery for driving same.

My improvements in implements for shearing sheep are carried out as follows, reference being had to sheet 1 of the accompanying drawings, on which figure 1 is a side view of the shearing implement; figure 2 is a horizontal longitudinal section; and figure 3 is a vertical longitudinal section of the same. Figure 4 is a bottom or outside view of the comb or guard detached from the shearer; and figure 5 is a top or inside view of the same. Figure 6 is a sectional view of one of the teeth of the comb; and figure 7 is a partial top or inside view of a modification of the comb and knife used when the comb is made in one piece with the guard, described and claimed more fully hereafter.

Similar letters refer to similar parts on the different parts of this sheet of the drawings.

A represents the handle of the machine, to which is attached the hood B, covering, so far as is necessary, the cutting and sharpening mechanism. Encased within the handle A is the mechanism which operates the sharpeners and the shaft which conveys rotary motion to the knife K and the emery wheel G. The top of the handle is made in the form of a hinged cover, *a*, which allows the mechanism contained therein to be exposed for repairs, and to be oiled; and the top of the hood is also made in the form of a hinged cover, *b*, for a like purpose. To the lower end of the handle A is hinged the comb or guard C, which forms a cover for the under part of the hood B, and is held in place when closed by a suitable catch or spring, D. A shaft, *e*, runs through the handle A, and has one end projecting from the rear of the handle by which it may be attached to any suitable motor. To the other end of the shaft, which projects into the hood B, firmly attached or made in one piece with said shaft, is a gear which meshes into the knife gear L, and conveys a rotary motion to the circular knife K, firmly held between a flange on the bottom of the knife gear and a nut fitting the thread cut on the knife gear below the teeth of the same when the guard is closed. The shaft *e* is held in place by a collar, J, fitting into a circular groove turned in the shaft near its rear end. Loose on the shaft *e* is a shell or case, E, which can be moved forward, independent of the shaft or the revolution of the shaft, by the action of the lever *g*, the upper portion of said lever being a pinion meshing into a circular series of teeth, *h*, forming a rack on the shell E. A suitable spring forces the shell E back into place when the pressure is removed from the lever *g*. The object of having the shell E slide on the shaft *e* is to force the emery wheel G against the edge of the circular knife K to sharpen the knife. The emery wheel G is kept in a continuous rotary motion by a level gear, F, splined on the shaft *e*, and revolving with it, but having a free movement forward and back with the shell E, in which it is encased; said gear F meshing into a small gear on the shaft carrying the emery wheel G. The end of the shell E, carrying the emery wheel G and its driving gear, is suitably fastened to the body of the shell, and thus forms a closed box for the level gear, protecting them from dirt or clogging with wool. A rack and pinion, I, is formed by lines cut lengthwise on the shell E, which receives the thread of a screw, operated by a suitable thumb wheel outside the shell of the handle A. The object of the rack and pinion is to turn and hold in position on the shaft *e* the shell E, thereby raising or depressing the emery wheel G.

It will be seen that when the comb or guard C is swung away from the hood B, as partly shown in figure 1, the knife and knife gear are not in contact with any revolving part of the machine, and are consequently motionless, and can be readily removed if so desired. When the comb or guard C is closed against the hood B the knife gear L meshes into the gear on the end of the shaft *e* and revolves with its knife K on the stud or projection on the comb or guard C. The comb or guard C is preferably made in two pieces, a forward portion, *c*, having its front divided into a suitable number of teeth or projections, *i*, and having a tongue projecting from its lower side backwards which fits into a groove in the main part of the comb or guard C, and which is held in position and made adjustable by means of a set screw, *l*, in a slot in the tongue. Thus it will be seen that as the knife is worn off by sharpening the forward portion, *c*, of the comb or guard C may be adjusted so as to bring the cutting edge of the knife K the right distance from the end of the teeth *i*. I do not wish to confine myself to this precise manner of making the comb or guard C, as it may be made in one solid piece, and have the teeth *i* on its front end made to radiate, or nearly radiate, from a common centre a little back of the centre of the knife K, as shown in figure 7, by which means the wool which comes between the outer teeth will be guided against the edge of the knife K, although the knife be worn off considerably from its original size.

Referring to figure 6, which represents a longitudinal section of one of the teeth *i*, of the forward portion *c* of the comb or guard C; the first step *n* being the portion above which the knife K runs, allowing the wool to be cut, and by passing to the next step or depression freeing itself from the binding of the knife should the tendency be to that result; the wool is further freed from lateral pressure by expanding into the openings or holes *r* at the base of the slots between the teeth.

In the main body or rear portion of the comb or guard C is the edge-straightener H, consisting of a frame held in place by a spring, O. In the said frame, revolving freely on a pin, is a cylinder of hard material, preferably of very hard steel. As the edge of the knife K is ground by forcing the emery wheel G against it, the edge is turned downwards, and as it passes directly from the emery wheel G to the edge-straightener H it is pressed against the steel roll of the straightener H, and the edge pressed out straight, being then presented at right angles to the wool. The revolving of the roll prevents any wear on the roll by the grinding action of the knife K, its action being to press out the edge of the knife under the force of the emery wheel G, while by its revolutions it continually presents a new surface to the knife-edge. The edge-straightener may also be made by simply securing a piece of hard material firmly to the rear portion of the comb or guard C, in such a position that the edge of the knife K will be forced against it by the action of the emery-wheel G, and the cutting edge of the knife be straightened; but I prefer to make the edge-straightener in the form of a cylinder, as above described.

My improved machinery for driving what are known as power sheep-shears is shown in sheet 2 of my drawings, where figures 8 and 9 show respectively front and side views thereof as driven from a shaft supported in stationary bearings, in contradistinction to a shaft having bearings on a portable or removable standard or framing, from which my machinery may be driven, if so desired. Figure 10 shows view of the



*Improvements in Implements for Shearing Sheep, &c.*

the opposite side of the brackets, &c., to that shown in figure 9; figure 11 shows top view of the upper bracket and its attachments; and figure 12 shows bottom view of the gearing at that corner of the machinery opposite to which it is drawn.

A is the main shaft supported in bearings A<sup>1</sup>, fixed to any convenient supports having the friction wheel A<sup>2</sup> fastened to said shaft by set screws as shown, and the fast and loose pulleys A<sup>3</sup> thereon. B is what I call the lower casting, and C the upper one. The lower one, B, is supported by sleeve B<sup>1</sup> on main shaft A. At the lower end of its stem it has a projecting hollow boss, B<sup>2</sup>, through which the vertical tube D passes. From its upper part are two other hollow bosses, B<sup>3</sup> and B<sup>4</sup>, one on each side, B<sup>3</sup> for the reception of the vertical tube D, and B<sup>4</sup> being tapped at the top to receive the screwed end of guide rod E. B<sup>3</sup> has a second and smaller hollow boss, B<sup>5</sup>, projecting from it, through which passes set-screw B<sup>6</sup>. From the side of B<sup>4</sup> there also projects (parallel to sleeve B<sup>1</sup>) another boss, B<sup>7</sup>, into which is screwed the tap bolt or spindle for the lower half of the toggle joint F to work on. Below hollow boss B<sup>2</sup> is a spiral spring, G, resting against fixed collar D<sup>1</sup> on vertical tube D for giving an elastic pressure to the leather friction pulley C<sup>5</sup> against the friction wheel A<sup>2</sup> when in motion.

The lower casting is connected to the upper one by toggle joint F, on the lower half of which is a lip, F<sup>1</sup>, for supporting the socket H of the regulating arm H<sup>1</sup>. This socket projects from the upper half of toggle joint F, as shown, and said upper half works on tap bolt or spindle F<sup>2</sup>, screwed into boss projecting from one side of the groove C<sup>1</sup>, which forms the guide for rod E. The top portion of this upper casting forms an oblong framing, C<sup>2</sup>, in each end of which are bearings for spindle C<sup>3</sup>, carrying bevel spinion C<sup>4</sup> and leather friction pulley C<sup>5</sup>. This framing is supported from the boss C<sup>6</sup> of the upper casting by arm C<sup>7</sup> on one side, and by the projecting part C<sup>8</sup> and its upward continuation, in which is the groove C<sup>1</sup>. C<sup>9</sup> is a solid projection, having a flat face which rests upon the set screw B<sup>6</sup>. Bevel pinion C<sup>4</sup> gears into another bevel pinion, J, at top of shaft J<sup>1</sup>, which passes through tube D. This tube is screwed at its upper end into the boss C<sup>6</sup> of upper casting. Said shaft J<sup>1</sup> has another bevel pinion, J<sup>2</sup>, at its lower end gearing into a bevel wheel, K, working in bottom carrier K<sup>1</sup>, and which drives another bevel pinion at end of shaft K<sup>2</sup> passing through tube L. K<sup>3</sup> is a flexible shaft in the shape of a spring, having a socket at either end, one of which screws on to the shaft K<sup>1</sup>, and the other receives the screwed end of the shearing implement M. N is a spring-stay for relieving the operator of part of the weight of the implement and of the lower portion of its driving gear. H<sup>2</sup> is a rod attached to regulating rod H<sup>1</sup>, and having a hook, H<sup>3</sup>, at its extremity in which the implement can be rested when not in use.

It will be evident that the shaft A may be hung in any other suitable bearings than that shown on the drawing, such as seated upon vertical standards fixed to the floor, or bearings seated on brackets, or in hangers, or otherwise, to suit the convenience of the building or place where the machine is to be erected.

The mode of operation is as follows:—Motion being imparted to fast pulley A<sup>3</sup>, drives it along with shaft A and friction wheel A<sup>2</sup>. It being now desired to start the machine, the hand-rod H<sup>2</sup> is pressed upwards, which causes the toggle F to assume the position shown in figure 9, which allows the top, casting C and attachments to fall with it, and consequently the leather friction pulley C<sup>5</sup> to come in contact with the driven friction wheel A<sup>2</sup>, which drives it with spindle C<sup>3</sup> and the bevel gearing C<sup>4</sup> and J, which communicates motion to vertical shaft J<sup>1</sup>, having the bevel pinion J<sup>2</sup> fixed to its lower end, which drives the bevel gearing affixed to the shaft K<sup>2</sup>, which imparts motion to the flexible shaft K<sup>3</sup> attached to it, and through it to the projecting end of the shaft e, which gives rotary motion to the knife gear L and the knife K; it also simultaneously sets in revolution the emery wheel G by means of the spline gear F and connecting mechanism; upon pressing the comb-teeth *i* upon the skin of the sheep and moving the whole machine forward the wool enters the slots between the teeth *i*, and is cut when it reaches the revolving knife K, the teeth *i* preventing the knife K from reaching the skin of the sheep. The front of the hood B ploughs off the cut wool as a fleece, and the short wool on the sheep draws out from between the teeth *i* as the machine is pushed forward.

When the knife K becomes dull the lever *g* is pressed, which moves the shell E forward, carrying the revolving emery wheel G with it, and forces the emery wheel against the knife K, while the knife is also revolving, thereby grinding the edge of the knife.

After the knife has been ground the edge is set or straightened by the edge-straightener H. The knife may be sharpened while in the act of shearing, and while pushing forward the machine, if so desired.

When it is required to stop the machine the hand-rod H<sup>2</sup> is pulled down, thereby causing the toggle to take its nearly vertical position, raising with it the upper casting C and its attachments, and consequently disconnecting the friction gear, as shown at figure 10.

What I believe to be new, and therefore claim as my improvements in implements for shearing sheep, and in machinery for driving same, is:—

First—The combination of the handle A, shaft e, and shell E.

Second—The combination of the shaft e, spline gear F, and small gear and emery wheel G.

Third—The combination of the shaft e, shell E, and rack and pinion I.

Fourth—The combination of the handle A, shell E, and pinion lever *g*, and rack *h*.

Fifth—The combination of the handle A with the hinged comb C.

Sixth—The combination of the handle A, containing mechanism for driving rotary circular cutter, with hinged comb C and hood B.

Seventh—A comb or guard, consisting of a main support, C, and adjustable forward portion, e, as herein described.

Eighth—A comb or guard, having the slots between the teeth enlarged at their base.

Ninth—An edge-straightener, consisting of a cylinder held and revolving in proper position to receive the edge of a revolving knife or cutter.

Tenth—An improved shearing device, consisting of a circular knife, K, and emery-wheel, G, and a comb or guard, C, all attached to a handle, A, a mechanism for transmitting motion through said handle to use said knife, emery wheel, and comb or guard, substantially as described.

Eleventh—The combination of a comb or guard, C, a circular knife K, and an edge-straightener H, substantially as described.

Twelfth—The combination of the two brackets A and B, by means of a toggle-joint, F, regulated by arm H<sup>1</sup> and hand-rod H<sup>2</sup>, substantially as and for the purposes described.

Thirteenth—

---

*Improvements in Implements for Shearing Sheep, &c.*

---

Thirteenth—The combination with such brackets of friction wheel A<sup>2</sup>, and leather friction pulley C<sup>6</sup>, substantially as and for the purposes described.

Fourteenth—The adjustable set-screw B<sup>6</sup> and the opposite face of boss C<sup>9</sup>, the lip F<sup>1</sup> on lower half of toggle-joint and the socket H on upper half thereof, the spring G and the spring-stay N, all in combination with the other parts of my driving machinery, and as and for the respective purposes herein described and explained.

In witness whereof, I, the said Joseph C. Wightman, have hereunto set my hand and seal, this fourteenth day of June, one thousand eight hundred and eighty-three.

JOSEPH C. WIGHTMAN,  
By his duly authorised Attorney,  
EDW. WATERS.

Witness—

W. S. BAYSTON,  
Law Clerk, Melbourne.

---

This is the specification marked A referred to in the annexed Letters of Registration granted to Joseph C. Wightman, this fourteenth day of August, A.D. 1883.

AUGUSTUS LOFTUS.

---

REPORT.

---

Sir,

In reply to your B.C. minute of 18th June, forwarding application of Joseph C. Wightman for Letters of Registration for an invention entitled "Improvements in Implements for Shearing Sheep, and in Machinery for driving same," we have to report that we see no reason why such letters should not be issued.

We have, &c.,

JAMES BARNET.  
WILLIAM C. BENNETT.

The Under Secretary of Justice.

---

[Drawings—two sheets.]

J C WIGHTMAN'S PATENT.

FIG. 1.

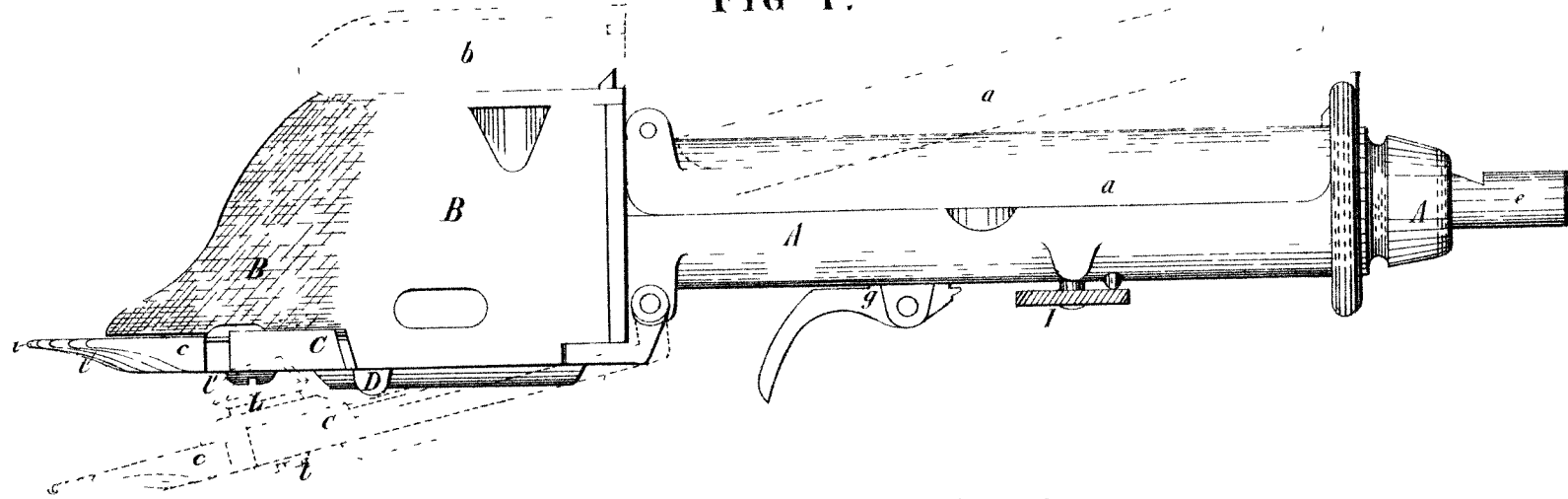


FIG. 4.

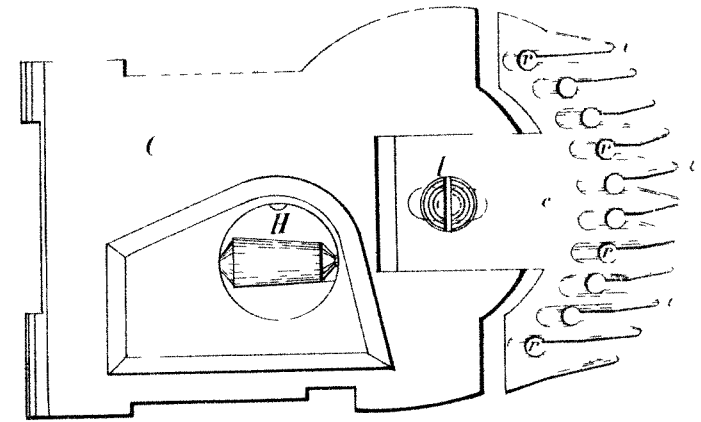


FIG. 2.

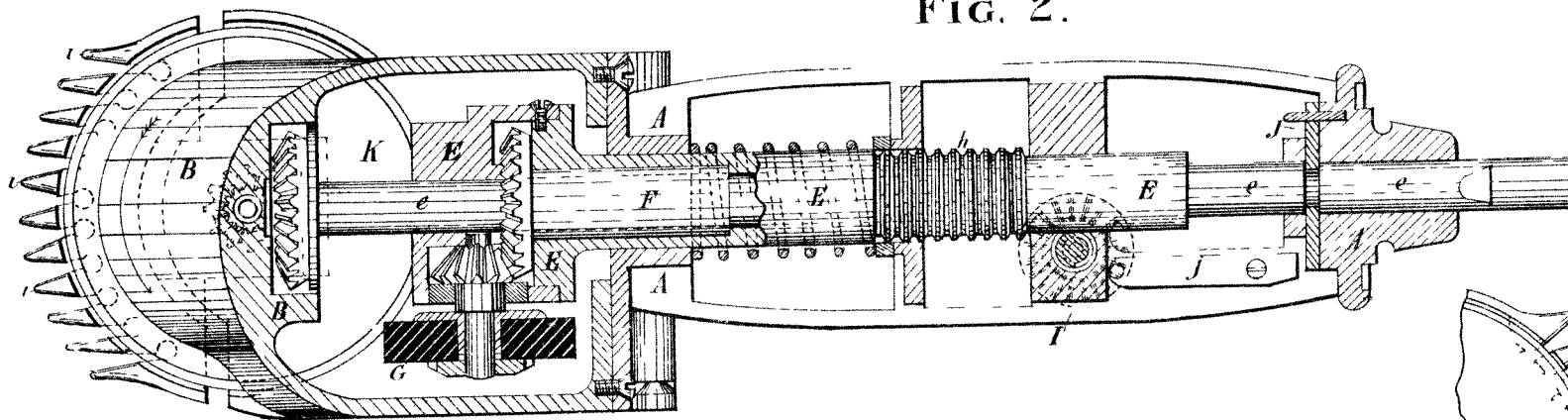


FIG. 5.

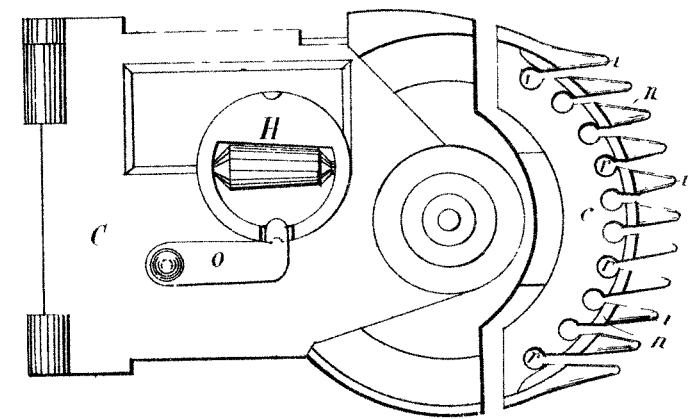


FIG. 7.

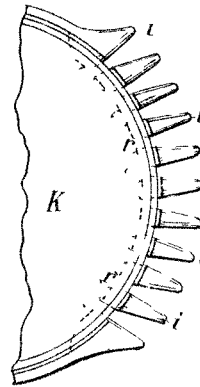


FIG. 3.

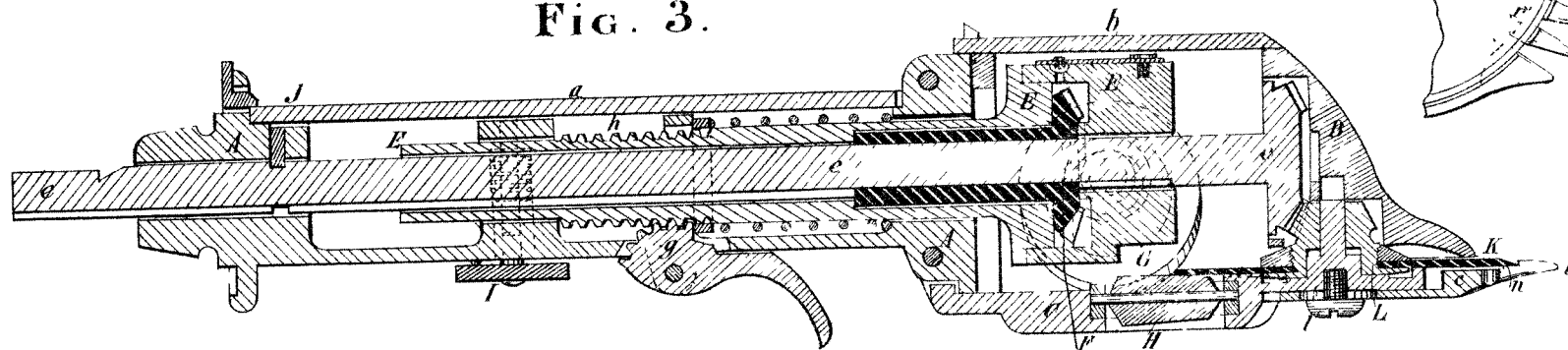


FIG. 6.



This is the Sheet of Drawings marked B preferred to in the annexed letters of Registration granted to Joseph C Wightman, this fourteenth day of August, A. D. 1883. Augustus Loftus.

C

J. C. WIGHTMAN'S PATENT.

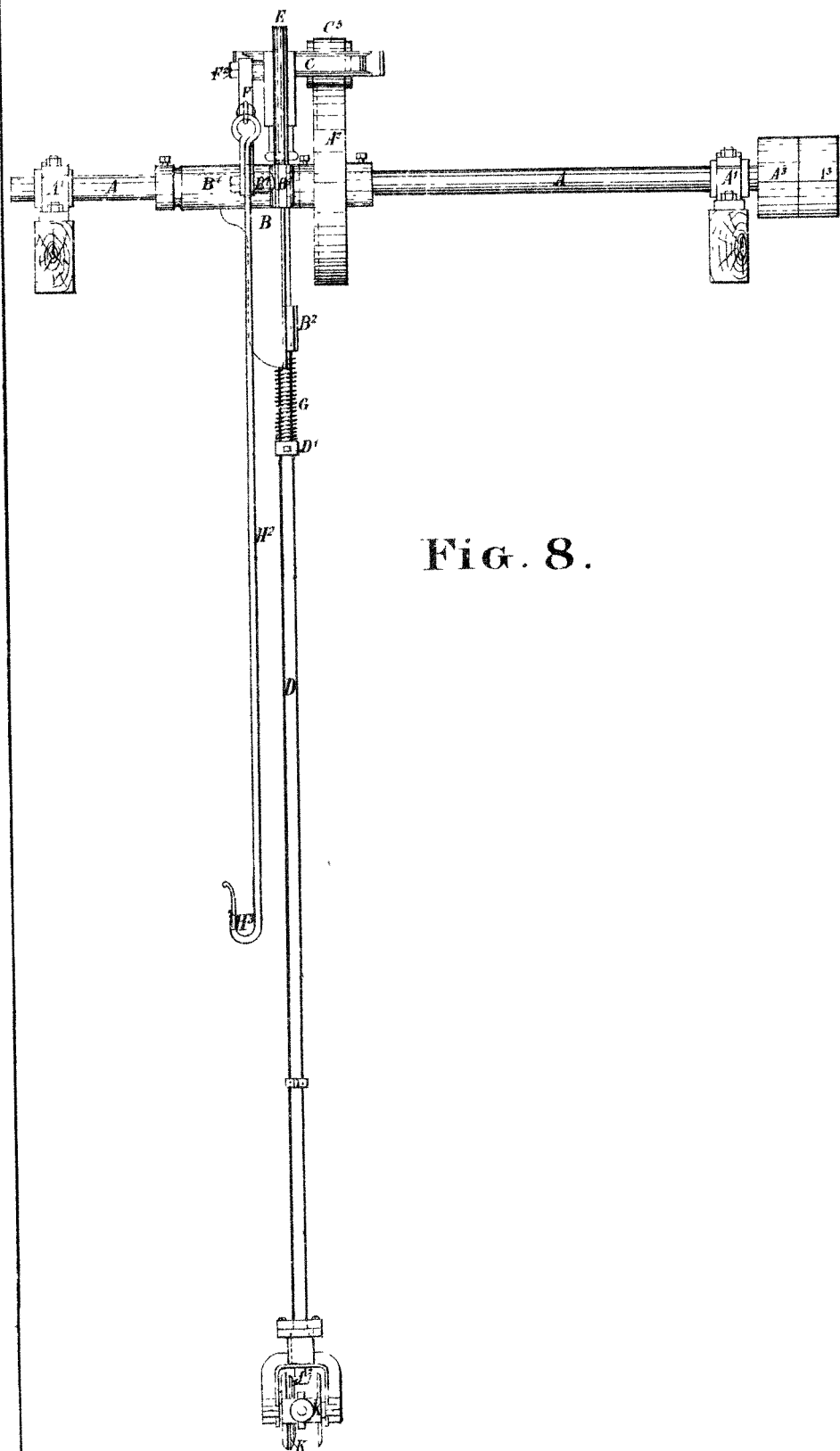


FIG. 8.

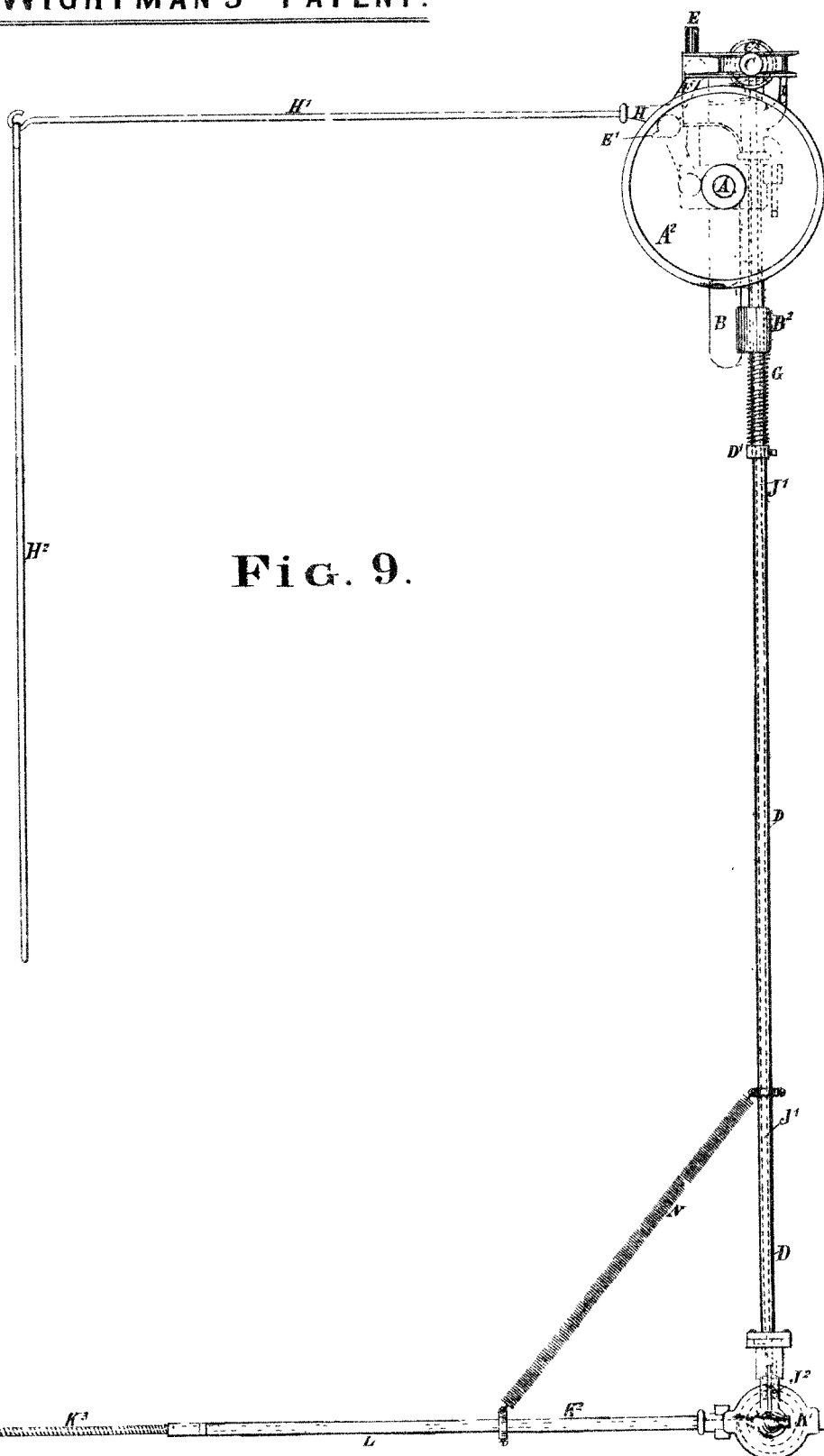


FIG. 9.

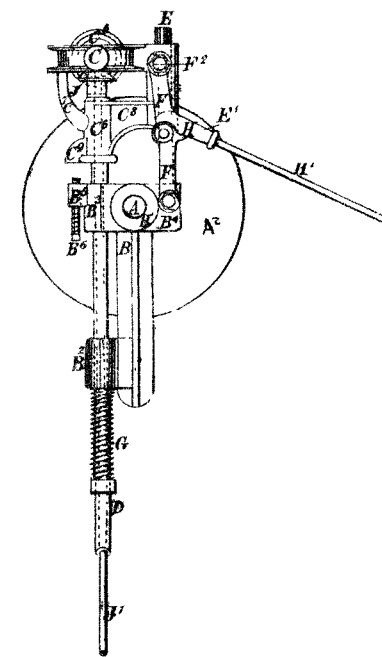


FIG. 10.

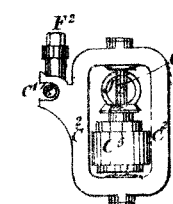


FIG. 11.

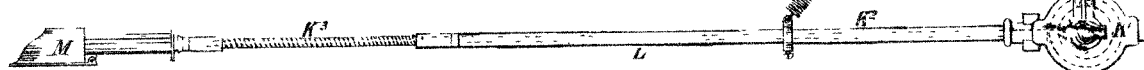


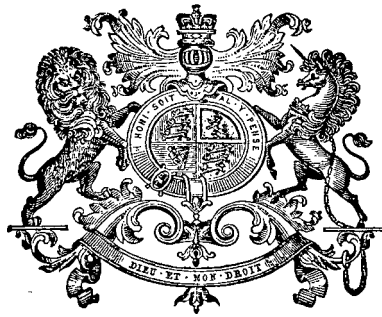
FIG. 12.



Fig. 13.

*This is the Sheet of Drawings marked C. referred to in the annexed Letters of Registration granted to Joseph C Wightman, this fourteenth day of August A. D. 1883.*  
*Augustus Loftus.*

PHOTO-LITHOGRAPHED AT THE GOVT. PRINTING OFFICE, SYDNEY, NEW SOUTH WALES.



A.D. 1883, 16th August. No. 1296.

IMPROVEMENTS IN AND CONNECTED WITH THE MANUFACTURE OF COKE.

LETTERS OF REGISTRATION to John Jameson, for Improvements in and connected with the Manufacture of Coke.

[Registered on the 17th day of August, 1883, in pursuance of the Act 16 Vic. No. 24.]

BY HIS EXCELLENCY THE RIGHT HONORABLE SIR AUGUSTUS WILLIAM FREDERICK SPENCER LOFTUS (commonly called LORD AUGUSTUS LOFTUS), Knight Grand Cross of the Most Honorable Order of the Bath, a Member of Her Majesty's Most Honorable Privy Council, Governor and Commander-in-Chief of the Colony of New South Wales and its Dependencies.

TO ALL TO WHOM THESE PRESENTS SHALL COME, greeting :

WHEREAS JOHN JAMESON, of Akenside Hill, Newcastle-upon-Tyne, in the Kingdom of England, consulting engineer, hath by his Petition humbly represented to me that he is the author or designer of a certain invention or improvement in manufactures, that is to say, of an invention entitled "Improvements in and connected with the Manufacture of Coke," which is more particularly described in the specification and the sheet of drawings which are hereunto annexed ; and that he, the said Petitioner, hath deposited with the Honorable the Treasurer of the said Colony of New South Wales the sum of Twenty Pounds sterling for defraying the expense of granting these Letters of Registration, as required by the Act of Council, sixteenth Victoria, number twenty-four ; and hath humbly prayed that I would be pleased to grant Letters of Registration, whereby the exclusive enjoyment and advantage of the said invention or improvement might be secured to him for a period of fourteen years : And I, being willing to give encouragement to all inventions and improvements in the arts or manufactures which may be for the public good, and having received a report favourable to the prayer of the said Petition from competent persons appointed by me to examine and consider the matters stated therein and to report thereon for my information, am pleased, with the advice of the Executive Council, and in exercise of the power and authority given to me by the said Act of Council, to grant, and do by these Letters of Registration grant unto the said John Jameson, his executors, administrators, and assigns, the exclusive enjoyment and advantage of the said invention or improvement, for and during the term of fourteen years from the date hereof ; to have, hold, and exercise unto the said John Jameson, his executors, administrators, and assigns, the exclusive enjoyment and advantage thereof for and during and unto the full end and term of fourteen years from the date of these presents next and immediately ensuing, and fully to be complete and ended : Provided always, that if the said John Jameson shall not, within three days after the granting of these Letters of Registration, register the same in the proper office in the Supreme Court, at Sydney, in the said Colony of New South Wales, then these Letters of Registration, and all advantages whatsoever hereby granted, shall cease and become void.

In witness whereof, I have hereunto set my sign manual, and have caused the present Letters of Registration to be sealed with the seal of the said Colony of New South Wales, at Government House, Sydney, in New South Wales, this sixteenth day of August, in the year of our Lord one thousand eight hundred and eighty-three.

[L.S.]

AUGUSTUS LOFTUS.

*Improvements in and connected with the Manufacture of Coke.*

SPECIFICATION of JOHN JAMESON, of Akenside Hill, Newcastle-upon-Tyne, England, consulting engineer, for "Improvements in and connected with the Manufacture of Coke."

My invention consists of a method whereby what is called hard coke can be manufactured without the loss of all the products of distillation, as is usual in the ordinary processes of the manufacture of hard coke. I construct the coke-oven with one or more passages in the floor or lower part, but otherwise of the ordinary construction.

The passages are connected to a range of pipes and an exhauster with condensing pipes and other appliances to separate the various products obtained. The oven is charged as usual, and when well ignited on the top I apply gentle exhaustion at the bottom through the passages and pipes referred to, so as to remove a part of the nascent products of distillation, instead of allowing them to pass up through the ignited portion of the charge. As this has the effect of impoverishing the coke and making it more soft, I use part or the whole of the gas so extracted, and part or the whole of the rich hydrocarbon tar, in a similar oven at a more advanced stage of ignition, so as that the carbon of the hydrocarbon gas or vapour shall be deposited on and within the interstices of the coke so treated, and the hydrogen shall be burned at the surface or passed away to burn in the chimney. The difference between my process and the usual method of manufacturing coke being this—instead of allowing the products of slow distillation, liberated by the descending heat, to pass direct into the upper part of the same oven, I remove them from the oven, generating them and separating the more valuable parts—as the ammonia and certain of the products of tar, which are more or less useless for the enrichment of the coke and absolutely wasted—I pass the gas and other hydrocarbons or a part of them into an oven in an advanced condition as regards ignition, so as more effectually to deposit the carbon contained, and to give great density and compactness to the coke produced.

Having thus described the nature of my invention, I will proceed more particularly to describe a mode of performing the same in and by the following statement, and by aid of the accompanying sheet of drawings, which represents a simple apparatus adapted for use in the process; and, before describing the process and apparatus, I wish it to be clearly understood that I do not necessarily limit myself to this precise form of apparatus, and my said invention, or parts of my said invention, may be used together or separately, that is to say:—I may extract more or less the products of the slow distillation of coal in a coke-oven ignited and burned in the usual way, and use these products in whole or in part for any other purpose than that already described; or I may employ hydrocarbons obtained in any other way for the enrichment of coke by the process described; or I may store in a gasometer the gas obtained from a certain coke-oven, to be returned in whole or in part at a later stage to the same or another oven. I may, in certain cases where there is considerable depth of very rich coal, simply provide a means of exit for the nascent gas otherwise than through the fire; but I prefer, as a matter of convenience of arrangement, to use the invention as a whole, substantially in the manner herein set forth. I have described the oven as of the ordinary construction, by which I do not mean of necessity the most ordinary construction, but of any ordinary construction wherein the charge is ignited and burned in the ordinary way, regard being had to the fact that it is desirable so to proportion the depth of coal operated upon and the position of the suction orifices and supply pipes as that air shall not (unless in small quantities) be liable to be drawn through the ignited coke, and that on the return of the gas it shall not have so small a surface to deposit upon as that, unless in small quantities it escapes from the ignited mass before being sufficiently decomposed. I wish further to draw attention to the following point, namely, whereas, in the gradual coking of the coal, there is ordinarily formed a species of more or less air-tight diaphragm, due to the caking of good coking coal, just at the point at which the heat becomes adequate to produce this agglomeration of particles, and therefore suction may be applied almost exclusively at any one point below this diaphragm without much risk of cutting an air passage in or near the shortest line towards it, yet after the mass of coke has become entirely ignited, the protection of this diaphragm is gone, and I therefore prefer to use a more diffused system for the supply of gas, by means of a more extended series of pipes than is necessary for the extraction of the gas; and I may use an entirely different set of pipes and differently arranged, so as to give a large number of passages for the supply of gas, and so as to be able to regulate, from the appearance of the oven, more or less supply to certain parts. I may also, combining the distillation of tar with the other process, supply, through the supply-pipes I have referred to or any of them, a certain quantity of pitch or more or less distilled tar or common raw tar, so as to produce very dense deposit. I desire also to draw attention to the fact that, in certain places where the value of the products of distillation of coal may bear a more than usual proportion to the value of the coke, I may apply such suction to the oven as to extract as much of the products of distillation as possible; but, when the products of distillation are of less value, I prefer to diminish the quantity extracted, so as to avoid risk of passing air from inattention. In order to diminish the risk of passing too large a quantity of air into the ignited coke, and so consuming more than is desired, I may also supply the upper part of the oven chamber with a portion of the waste gases of the chimney, at or about atmospheric pressure, so as that if air or gas, beyond that generated by the heating of the coal, should pass through the mass of ignited cinder by means of the suction, it may be an air or gas which is comparatively inert in the consumption of the coke, from having been in whole or in part already burned. In order to more clearly illustrate the nature of my invention, and the manner of performing the same, I will now proceed to describe a form of apparatus adapted for the working of the same, reference being had to the accompanying drawing. A, B, and C represent three coke-ovens, each with its charge of coal. These charges are represented by shaded and cross-shaded lines. By the single shaded lines I represent raw coal, and by the cross shaded lines I represent coal after its ignition. The oven C being supposed to be that first charged, then B and A respectively as more lately charged, the position of the shaded lines representing the progress made towards ignition. The dividing lines between the singly and doubly shaded lines in the charge represent the imaginary position of a stratum of coal which has become more or less agglomerated by heat, and which forms a diaphragm more or less tenacious and resistant to the passage of gas or air, as hereinbefore mentioned. D is a pipe, a branch from which passes into and terminates in the bottom of each oven, the orifice of which branch within the oven is covered with a fire-clay quarl, so as to keep coal or cinder out of the pipe. I show in the drawing one pipe and one orifice only to each oven for the sake of clearness, but one or more may be used. The pipe

*Improvements in and connected with the Manufacture of Coke.*

D communicates with a range of cooling-pipes, shown at E, similar to those used in gas-works, and thence with the exhauster at G, of any convenient form. That which I have shown at G is an air-pump. For the sake of clearness I show the connection through the exhauster direct to a second pipe, H, communicating with each oven. There are provisions represented as sections of stop-cocks near the junction of each pipe and oven, so as to enable me to open or close communication at will. These stopcocks are shown at I and J, those marked I being closed and those marked J open.

If, in these circumstances, the exhauster be not operated, and thereby the passage D be practically closed, the nascent gas liberated in the heated coal under the most tenacious part of the diaphragm I have described will force its way up through this diaphragm; and, although part of its hydrocarbon may be decomposed by contact with the incandescent coke above it, a considerable part will and does usually arrive at the surface of the charge, and this portion burns with a more or less white flame, and is practically wasted; but if the exhauster be operated so as that the pneumatic pressure below the diaphragm hereinbefore mentioned is less than the pressure above the said diaphragm, the gas formed will pass by the course of such pressure and escape decomposition, and, in the range of cooling pipes, the water, ammonia, tar, and other merely volatile products may be condensed, *mutatis mutandis*, and, having regard to the considerations before referred to, the supply of gas is like to the exhaustion—it may be effected by suction at the top of the oven; as, for instance, by connection to a good chimney while the door is well closed, or by pressure from the pressure of the exhauster, as shown in the drawing, or from a gasometer or otherwise, the quantity of gas supplied being regulated by consideration of the relative values at the place where the process is carried on of the gas and coke produced respectively.

Various processes have been devised whereby the volatile products of coal given off in the manufacture of coke are more or less effectually recovered, the most ordinary process for this purpose being, so far as I am aware, the more or less closing of the oven and the application of heat other than that arising in the usual form of open oven from the direct combustion of the coal being coked.

Some of these processes involve a considerable amount of complication in the apparatus employed; some, from application of heat at what I consider the wrong part of the oven, produce a spongy coke; in some, I believe, the heat possible to be economically applied is not adequate to produce the high density desirable in hard coke.

By my invention, I employ the heat generated by the direct combustion of a part of the coal being coked, and I am enabled to employ an extremely simple form of apparatus and to recover more or less perfectly, as desired, the volatile products; and I can utilise, in a simple way, for the enrichment of the coke produced, more or less of the gases and volatile products obtained.

The following are variations, modifications, or improvements upon the foregoing processes, or analogous processes, which it may be found convenient or beneficial in some cases to adopt:—

I find that in the coking of coal in the manner hereinbefore described that if the exhaustion be not too great there is slight (if any) loss of weight of coke, and the pitch is consolidated in a greater or less degree and left in the lower part of the charge, and thus tends to produce a very hard and dense coke. The pitch, however, so retained contains certain valuable products, which are therefore lost. I, therefore, in cases (where from local circumstances or otherwise it is very desirable to obtain these products) supply in the charge of coal a certain quantity of pitch, from which the products referred to have been extracted, so as to melt and wash down the more valuable pitch and replace it, or I apply a solution of pitch in some of the less valuable oils. For this purpose, I effect this either by grinding a certain quantity of pitch with the coal, or by damping the coal to be coked, either before or after its introduction into the oven, with a solution of pitch in any inferior description of oil in which it is soluble.

I also find that by continuous and uniform suction, limited in extent, so as to avoid cutting passages in the coke produced and wasting it, there is a less yield of heavy oils and pitch than I think might with advantage be extracted; and I therefore apply a much increased suction for a very short time, either once in the process of coking, or at intervals, so as both to consolidate the uncoked coal in the lower part of the charge, and to extract an increased proportion of the heavy oils and pitch. I prefer to effect this extra suction by having an extra range of pipes outside the oven, with an extra means of producing higher exhaustion, and such appliances as cocks or screw down or sluice valves for shutting off the ordinary and turning on the extra exhaustion as may be required to each oven separately.

I also find that in passing gas into a coke-oven in a state of incandescence, as hereinbefore described, that if the gas be cold and in considerable quantity the oven is so cooled as to cease to decompose the gas. I therefore heat the gas to be so supplied, or I may so arrange the system of pipes connected with the oven as that the gas which has passed from one oven, more or less cooled down, may be passed to an oven in a more heated state, and from thence, if required, to a still more highly heated oven, so as more perfectly to deposit its contained carbon. I prefer to effect the more perfect deposition of the carbon contained in the gas by heating it in a separate range of pipes to such extent as not to decompose it, produce any deposit of soot, and I may then pass it or part of it into the upper part of the oven without access of air, and pass it through the mass of incandescent cinder by suction below, or by pressure above, or both, or I may pass it by pressure from below upwards, or it may be passed in each direction in turn, so as that as much as possible it shall come into contact first with cinder, heated to such degree as to produce hard deposit instead of soot.

I find also it is possible to extinguish an oven by the passage of cold gas, and as this is sometimes better than extinguishing by water, I arrange to pass gas as last described, so as entirely to extinguish the oven or other cold inert gas. Such as the cooled waste gas of the chimney may be used, or I may apply steam in the same way while the charge is very hot, so as to extract a part of the sulphur.

The way in which gas or steam can be thus applied through the pipes, channels, and openings provided in the oven bottom is so obvious as to need no description of the method of its accomplishment. What is necessary to guard against is the presence of free oxygen or carbonic acid in any considerable quantity in the gas used for the purpose, the effect of which would be to reduce the yield of coke; and it is also desirable to avoid the use of hydro-carbon gas to such an extent as would produce deposit of soot or soft carbon when the heat becomes inadequate to produce deposit of hard carbon.



*Improvements in and connected with the Manufacture of Coke.*

I find also that there is, after the oven has become ignited throughout, a continued yield of hydro-carbon gas and oil, which I think arises from condensation of more or less fluid hydro-carbon in the brick-work bottom of the oven, and probably even in the foundation of it, seeing that by repeated heating and cooling the oven bottom becomes more or less opened and porous.

I therefore construct the bottom of the oven so as to be less pervious than usual by the introduction of an iron plate with only such quantity of brickwork over it as is necessary to preserve it from injury from the heat, and so that there may thus be a diminished reception and a more rapid and complete discharge of the volatile hydro-carbons condensing in the manner referred to; or I may saturate more or less perfectly the porous bottom of the oven with oils of little value before charging, so as more or less to prevent the absorption of more valuable oils during coking, and which inferior oils may, on being volatilized by the descending heat, be allowed to pass up through the ignited mass of coke on the cessation of the exhaustion. It will be evident that the iron plate referred to may be, however, replaced by a plate or layer of cement of any convenient kind, with only such protection of fire-brick over it as to prevent its disintegration by the heat of the oven. A convenient cement may be made from pitch, with or without solvent oils, with fire-clay used hot and with hot bricks in the building of the oven floor. The more or less saturation of the oven bottom with inferior oils results, I believe, in my being able to stop the exhaustion of the oven at an earlier stage than I might otherwise do, because the condensation of the oils emitted by the coal in the porous oven bottom is diminished, and the more valuable freshly generated oils pass into the suction pipe direct, instead of indirectly, after a second process of distillation. This saturation may be produced by watering the oven bottom with the oil or oils and pitch, or it may be produced by the introduction of oil or oils and pitch into the exhaust pipe and channels through a separate range of pipes, and in this latter case either before or after the charging of the oven.

I find also that considerable differences exist in the quality of the products obtained at different parts of the apparatus arranged as hereinbefore described, which differences I believe arise, to a large extent, from differences of temperature; and I therefore, in using my invention, arrange for separate collection of products while using merely the ordinary cooling process, or by means of artificial regulation of temperature—that is to say, both in regard to time from the ignition of the oven, and in regard to separation of the products at different parts of the condensing apparatus by difference of temperature. I may effect a species of fractional separation of products by, in the first place, leading the exhausted gas of the oven through different ranges of pipes at different times of the burning of the charge, and either in combination with this or otherwise I may tap the condenser pipes at intervals, so as to extract at one part oils, or ammonia and oils, condensing at one temperature, and at another part, or at other parts, oils, or ammonia and oils condensing at another or other temperatures.

As I find there is also produced a considerable quantity of oil of comparatively little value, either directly or it is separated in the treatment of the tar and oils by a separate process, I employ in certain cases a mixture of this oil and pitch to supply to the charge at the bottom of the oven, while in a highly heated state, so as that the pitch is more or less absorbed and consolidated in the coke, and the oil is caused to pass in the state of vapour through the ignited mass above it, and thus to deposit more or less its contained carbon.

Either in combination with the species of fractional separation of oils last described, or in connection with any process of separating valuable from inferior oils, I may apply a part of any inferior description of coal-oil, either alone or more or less mixed with pitch, by means of the pipes and channels of the oven bottom, and at a stage of the process when the exhaustion of the oven is completed, the charge entirely incandescent, and the oven bottom very highly treated so as that the oil, or oil and pitch, shall enter the pipes and channels and saturate the oven bottom, and be in part distilled into hydro-carbons, and these be in part deposited as carbon on the incandescent coke, and the pitch, in part, if a sufficient quantity be supplied, be converted into pitch coke with the evolution of hydro-carbon gas or vapour.

By the process of coking hereinbefore described, and especially if pitch in any way be used, there is produced in the lower part of the oven a dense deposit, and I use this deposit for the consolidation into good coke of a certain quantity of the breeze now usually wasted, the breeze being put into the lower part of the oven before charging with coal. The dense deposit referred to as produced in the process of coking in the bottom of the oven I believe arises from the soaking down of the pitchy semi-fluid portions of the coal and the oils, and that advantage may be taken of it if desired for the consolidation of a layer of coke breeze introduced into the oven before the coal. The thickness of the layer which can be so incorporated into the coke must depend upon the quantity of pitchy ingredients existing in or supplied to the coal under operation, as a very rich coal will take up more and a poor coal less.

In place of producing a difference of pressure in different parts of the oven, so as to assist the flow of gas in the same by exhausting from the bottom as hereinbefore described, I may produce this slight difference of pressure by a gentle pressure on the top of the oven, giving with this slight pressure an adequate supply of air to maintain combustion. I effect this object while still retaining the advantage derivable from using an open instead of a close oven, by enclosing the whole oven or range of ovens, and more or less the necessary tramways for charging and discharging, and space for working, within an approximately air-tight structure with double doors and spaces between the doors and valves to facilitate the opening of the doors, and within this structure I maintain a slight pressure of air derived from a fan or blower. I lead flues from the oven top or tops through the walls of the before-mentioned structure, and I lead pipes from the oven bottom through the walls, for the exit of the volatilized products of the coal carbonized.

I claim as my invention:—

First—The improvements in the manufacture of coke, consisting in extracting the gaseous products, or part of the gaseous products, of distillation at the bottom of the oven wherein the charge is ignited and burned in the ordinary manner, as hereinbefore described.

Second—The improvements in the manufacture of coke, consisting in passing hydro-carbon gas vapour or fluid through the incandescent charge, as hereinbefore described.

Third



---

*Improvements in and connected with the Manufacture of Coke.*

---

Third—The hereinbefore described various modifications or improvements upon the process of manufacturing coke, forming the subject matter of the preceding claims, whether the said modifications or improvements be applied to that exact process or to any analogous process of manufacturing coke.

In witness whereof, I, the said John Jameson, have hereunto set my hand and seal, this fourteenth day of May, one thousand eight hundred and eighty-three.

JOHN JAMESON.

Signed and sealed in the presence of—

WILLIAM MOORE, 20, Copeland-terrace, Shieldfield, Newcastle-on-Tyne.

L. NIXON, 3, Lowrey-st., Newcastle-on-Tyne.

This is the specification referred to in the annexed Letters of Registration granted to John Jameson this sixteenth day of August, A.D. 1883.

AUGUSTUS LOFTUS.

---

**REPORT.**

---

Sir,

Sydney, 10 July, 1883.

The application for Letters of Registration by Mr. John Jameson, for an invention entitled "Improvements in and connected with the Manufacture of Coke," having been referred to us, we have the honor to report that we have examined the specification and drawings accompanying the same, and see no objection to the issue of Letters of Registration as prayed for.

We have, &c.,

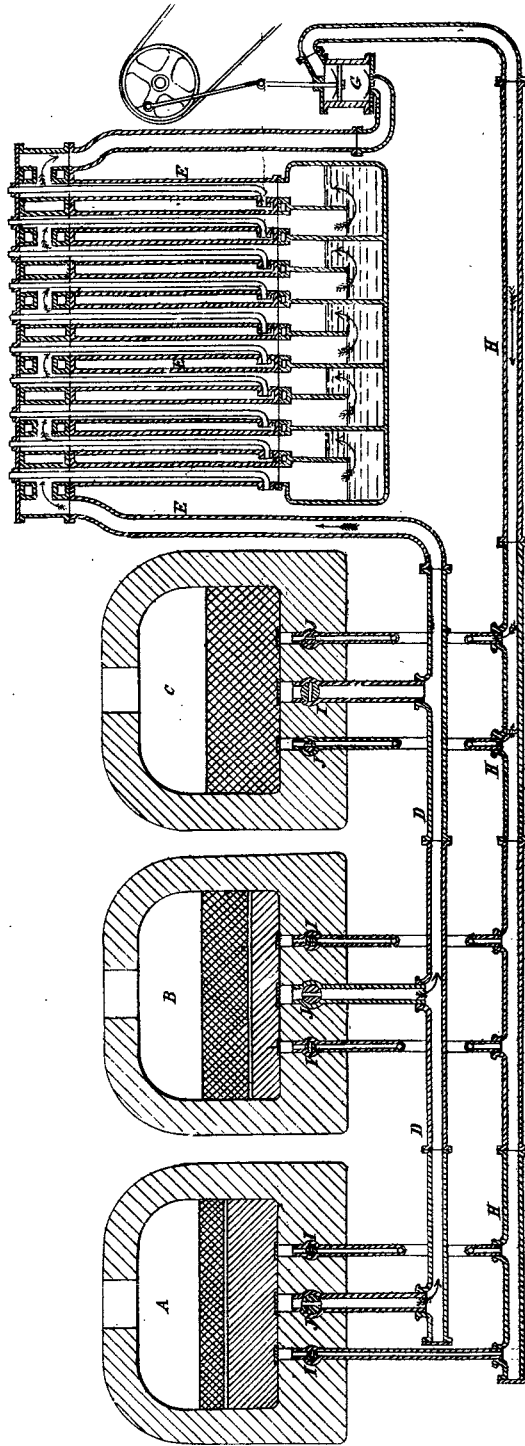
A. LEIBIUS.

CHAS. WATT.

The Under Secretary of Justice.

---

[Drawings—one sheet.]



*This is the Sheet of Drawings referred to in the annexed  
Letters of Registration granted to John Jameson, this  
sixteenth day of August A. D. 1883.*

*Augustus Loftus.*



A.D. 1883, 20th August. No. 1297.

**IMPROVEMENTS IN THE MANUFACTURE OF WHITE LEAD FROM METALLIC LEAD.**

**LETTERS OF REGISTRATION** to John Honeychurch Broad and William Thomas Poole, for Improvements in the manufacture of White Lead from Metallic Lead.

[Registered on the 21st day of August, 1883, in pursuance of the Act 16 Vic. No. 24.]

BY HIS EXCELLENCY THE RIGHT HONORABLE SIR AUGUSTUS WILLIAM FREDERICK SPENCER LOFTUS (commonly called LORD AUGUSTUS LOFTUS), Knight Grand Cross of the Most Honorable Order of the Bath, a Member of Her Majesty's Most Honorable Privy Council, Governor and Commander-in-Chief of the Colony of New South Wales and its Dependencies.

TO ALL TO WHOM THESE PRESENTS SHALL COME, greeting:

WHEREAS EDWARD JOHN HONEYCHURCH BROAD, of Park House, Enmore Road, Marrickville, engineer, and WILLIAM THOMAS POOLE, of Sydney, M.L.A., gentleman, have by their Petition humbly represented to me that they are the authors or designers of a certain invention or improvement in manufactures, that is to say, of an invention entitled "Improvements in the manufacture of White Lead from Metallic Lead," which is more particularly described in the specification which is hereunto annexed; and that they the said Petitioners have deposited with the Honorable the Treasurer of the said Colony of New South Wales the sum of Twenty Pounds sterling, for defraying the expense of granting these Letters of Registration, as required by the Act of Council, sixteenth Victoria, number twenty-four; and have humbly prayed that I would be pleased to grant Letters of Registration, whereby the exclusive enjoyment and advantage of the said invention or improvement might be secured to them for a period of fourteen years: And I, being willing to give encouragement to all inventions and improvements in the arts or manufactures which may be for the public good, and having received a report favourable to the prayer of the said Petition, from competent persons appointed by me to examine and consider the matters stated therein and to report thereon for my information, am pleased, with the advice of the Executive Council, and in exercise of the power and authority given to me by the said Act of Council, to grant, and do by these Letters of Registration grant unto the said Edward John Honeychurch Broad and William Thomas Poole, their executors, administrators, and assigns, the exclusive enjoyment and advantage of the said invention or improvement for and during the term of fourteen years from the date hereof; to have, hold, and exercise unto the said Edward John Honeychurch Broad and William Thomas Poole, their executors, administrators, and assigns, the exclusive enjoyment and advantage thereof, for and during and unto the full end and term of fourteen years from the date of these presents next and immediately ensuing, and fully to be complete and ended: Provided always, that if the said Edward John Honeychurch Broad and William Thomas Poole shall not within three days after the granting of these Letters of Registration register the same in the proper office in the Supreme Court, at Sydney, in the said Colony of New South Wales, then these Letters of Registration, and all advantages whatsoever hereby granted, shall cease and become void.

In witness whereof, I have hereunto set my sign manual, and have caused the present Letters of Registration to be sealed with the seal of the said Colony of New South Wales, at Government House, Sydney, in New South Wales, this twentieth day of August, in the year of our Lord one thousand eight hundred and eighty-three.

[L.S.]

AUGUSTUS LOFTUS.

---

*Improvements in the Manufacture of White Lead from Metallic Lead.*

---

TO ALL TO WHOM THESE PRESENTS SHALL COME: We, EDWARD JOHN HONEYCHURCH BROAD, of Park House, Enmore Road, Marrickville, engineer, and WILLIAM THOMAS POOLE, of Sydney, Member of the Legislative Assembly of New South Wales, gentleman, send greeting:

WHEREAS we are desirous of obtaining Letters of Registration for securing unto us Her Majesty's special license that we, our executors, administrators, and assigns, and such others as we or they shall at any time agree with, and no other, shall and lawfully may, from time to time, and at all times, during the term of fourteen years, to be computed from the day on which this instrument shall be left at the office of the Minister of Justice, Sydney, make, use, exercise, and vend, within the Colony of New South Wales, an invention of "Improvements in the manufacture of White Lead from Metallic Lead," as more particularly described in the following specification.

SPECIFICATION.

WE claim as our invention certain improvements for the rapid conversion of metallic lead into white lead (carbonate of lead) by first converting the metallic lead into an oxide known as litharge (protoxide of lead). This litharge is ground to a very fine powder, and put into a vessel containing a solution of chloride of sodium, potassium, or ammonium. We use chloride of sodium in the proportion of about 140 lb. to 560 lb. of litharge and 2,240 lb. of water; it does not necessarily follow that these exact proportions are essential, but we find them to work well and conveniently. This mixture is thoroughly agitated for a time, varying from three to five hours, according to the amount of agitation, the condition of the charge being ascertained only by examination. The result of this operation or process is the production of an insoluble basic chloride of lead in a solution of caustic soda and common salt. A stream of carbonic acid gas, under pressure, is now pumped into the charge, the agitation being still continued, and the charge frequently examined. The gas decomposes the base, and produces an excellent carbonate of lead; the time required, from one to five hours, depends upon the strength of the gas, its volume and pressure. The supply of gas and the agitation are now stopped, and the carbonate of lead allowed to settle, and as much as possible of the solution in which it was suspended drawn from it. The carbonate of lead produced is now washed in fresh water till freed entirely from salt, and allowed to settle, and as much as possible of the water drawn off; the proper quantity of oil is then thrown in, and agitation resumed. The carbonate of lead rapidly mixes with the oil, throws off the remainder of the water and other impurities, and produces more rapidly and more cheaply than by known processes a white lead ready for the market equal to white lead produced by any other method.

We claim the entire process and arrangement as substantially described and set forth in the foregoing detailed specification.

EDWARD JOHN HONEYCHURCH BROAD.  
WILLIAM THOMAS POOLE.

2, Wentworth Court, Sydney, 9th July, 1883.

(Per HENRY HALLORAN, Patent Agent).

This is the specification referred to in the annexed Letters of Registration granted to Edward John Honeychurch Broad and William Thomas Poole, this twentieth day of August, A.D. 1883.

AUGUSTUS LOFTUS.

---

REPORT.

---

Sir,

Sydney, 17 July, 1883.

The application of Messrs. Edward John Honeychurch Broad and William Thomas Poole for Letters of Registration for "Improvements in the manufacture of White Lead from Metallic Lead" having been referred to us, we have examined the specification accompanying the same, and have the honor to report that we see no objection to the issue of Letters of Registration as prayed for.

We have, &c.,

CHAS. WATT.  
A. LEIBIUS.

The Under Secretary of Justice.

---

No. 1298.

[Assignment of No. 1087. See Letters of Registration for 1882, page 229.]




---

A.D. 1883, *25th August.* No. 1299

---

**IMPROVEMENTS IN STEAM-ENGINES.**

**LETTERS OF REGISTRATION to Pardon Armington, for Improvements in Steam-engines.**

[Registered on the 25th day of August, 1883, in pursuance of the Act. 16 Vic. No. 24.]

BY HIS EXCELLENCY THE RIGHT HONORABLE SIR AUGUSTUS WILLIAM FREDERICK SPENCER LOFTUS (commonly called LORD AUGUSTUS LOFTUS), Knight Grand Cross of the Most Honorable Order of the Bath, a Member of Her Majesty's Most Honorable Privy Council, Governor and Commander-in-Chief of the Colony of New South Wales and its Dependencies.

TO ALL TO WHOM THESE PRESENTS SHALL COME, greeting :

WHEREAS PARDON ARMINGTON, of Lawrence, Massachusetts, United States of America, hath by his Petition humbly represented to me that he is the author or designer of a certain invention or improvement in manufactures, that is to say, of an invention entitled "Improvements in Steam-engines," which is more particularly described in the specification hereunto annexed marked A, and the two sheets of drawings marked B and C respectively, and which are hereunto annexed; and that he, the said Petitioner, hath deposited with the Honorable the Treasurer of the said Colony of New South Wales the sum of Twenty Pounds sterling for defraying the expense of granting these Letters of Registration, as required by the Act of Council, sixteenth Victoria, number twenty-four, and hath humbly prayed that I would be pleased to grant Letters of Registration whereby the exclusive enjoyment and advantage of the said invention or improvement might be secured to him for a period of fourteen years: And I, being willing to give encouragement to all inventions and improvements in the arts or manufactures which may be for the public good, and having received a report favourable to the prayer of the said Petition from competent persons appointed by me to examine and consider the matters stated therein and to report thereon for my information, am pleased, with the advice of the Executive Council, and in exercise of the power and authority given to me by the said Act of Council, to grant, and do by these Letters of Registration grant unto the said Pardon Armington, his executors, administrators, and assigns, the exclusive enjoyment and advantage of the said invention or improvement, for and during the term of fourteen years from the date hereof; to have, hold, and exercise unto the said Pardon Armington, his executors, administrators, and assigns, the exclusive enjoyment and advantage thereof for and during and unto the full end and term of fourteen years from the date of these presents next and immediately ensuing, and fully to be complete and ended: Provided always, that if the said Pardon Armington shall not, within three days after the granting of these Letters of Registration, register the same in the proper office in the Supreme Court, at Sydney, in the said Colony of New South Wales, then these Letters of Registration, and all advantages whatsoever hereby granted, shall cease and become void.

In witness whereof, I have hereunto set my sign manual, and have caused the present Letters of Registration to be sealed with the seal of the said Colony of New South Wales, at Government House, Sydney, in New South Wales, this twenty-fifth day of August, in the year of our Lord one thousand eight hundred and eighty-three.

[L.S.]

AUGUSTUS LOFTUS.

*Improvements in Steam-engines.*

## A.

SPECIFICATION of PARDON ARMINGTON, of Lawrence, Massachusetts, United States of America, for an invention entitled "Improvements in Steam-engines."

THIS invention relates to improvements in the construction of that class of steam-engines in which the piston moves at a high speed, and the supply of steam is automatically regulated so as to develop a uniform speed under variable resistance, and enable machinery to be run at a fixed speed under all variations of load that may be applied within the power of the engine.

The said invention partly consists in a peculiar and novel construction of the valve for regulating the supply of steam to the cylinder, by which construction a larger quantity of steam is supplied to the piston at the end of each stroke, and in less time than has heretofore been practicable. The said invention further consists in a peculiar and novel construction of the governor, by which the valve-operating excentrics are actuated directly by weights and springs operated by the centrifugal force generated by the speed of the revolving crank-shaft, as will be more fully set forth hereinafter. The said invention further consists in a peculiar and novel construction of the crank, and the means for balancing the same, as hereinafter described.

In the accompanying drawing,—

Figure 1 is a plan or top view of my improved steam-engine.

Figure 2 is a side elevation of the same.

Figure 3 is a side elevation partly in section of the improved governor, showing the excentric placed on the crank-shaft and controlled by the weights and springs.

Figure 4 is a vertical section of the governor.

Figure 5 represents the two excentrics at the two extremes of their movement, one in full and the other in broken lines.

Figure 6 is a longitudinal section of the steam cylinder and the valve for regulating the admission and emission of steam.

Figure 7 is a transverse section of the steam cylinder and the valve.

Figure 8 is a sectional elevation of the crank,—and

Figure 9 is a side view of the same, showing the balance-disc secured to the crank-disc.

Like letters indicate corresponding parts throughout the drawings.

A is the engine cylinder, one end of which is secured to the heavy frame A<sup>1</sup>, on which the slides A<sup>2</sup> for the cross-head and the bearings A<sup>3</sup> for the crank-shaft, are formed, so that, a solid and firm foundation and a permanent alignment of all the parts are ensured. B is the steam-chest, in which the valve B<sup>1</sup> regulates the admission of the steam to the cylinder. C is the stop valve, whereby the steam-supply pipe from the generator to the engine is opened or closed. D is the piston rod, E the connecting rod, and M the crank-pin. G G are balance discs secured to the crank disc to balance the weight of the crank-pin, the connecting rod, and other parts affecting the motion of the crank-shaft and parts connected therewith. H H are the fly-wheels, provided with broad rims to receive belts for transmitting the power generated by the engine. I is the excentric, connected through the rock-shaft I<sup>1</sup> and connecting rod I<sup>2</sup>, with the valve B<sup>1</sup>, so as to reciprocate the valve at each revolution of the crank-shaft.

Figures 6 and 7 clearly show the construction of my improved valve and its combination with the cylinder, the ports leading to each end thereof the cylinder, and the steam-supply and exhaust. The steam is admitted by the inlet B<sup>2</sup>; it will therefore be observed that the valve B<sup>1</sup> is at all times surrounded by the live steam. B<sup>3</sup> B<sup>3</sup> are the steam ports leading to the ends of the cylinder; these ports extend in the shape of grooves around the valve cylinder. B<sup>4</sup> B<sup>4</sup> are the exhaust ports formed at each end of the valve chest. The valve B<sup>1</sup> is of cylindrical form; the central portion *b* is tubular and of less diameter than the two ends, and is at each end provided with the bearing *b*<sup>1</sup> of larger diameter than the central part *b*, and with the end caps *b*<sup>2</sup>, also forming a bearing against the walls of the valve cylinder; between the bearings *b*<sup>1</sup> and the caps *b*<sup>2</sup> apertures *b*<sup>3</sup> are formed, which are made as nearly as possible annular, and extend entirely around the valve; these apertures communicate with the interior of the central portion *b*, and form an open duct from one end of the valve to the other. The valve is shown in figure 6 in the position it occupies when both the ports are closed, and steam is neither admitted to nor emitted from the cylinder; the live steam surrounds the valve, and thus a uniform temperature is maintained in the valve. When the valve moves in either direction, the port B<sup>3</sup>, from which it moves, will be at once placed in communication with the exhaust port B<sup>4</sup> and this end of the cylinder will discharge its steam freely, while the port B<sup>3</sup>, at the other end of the cylinder, will be placed in communication with the apertures *b*<sup>3</sup> and the central duct, and through them with the steam supply, and will at the same time communicate directly with the steam supply, as at that time the annular bearing *b*<sup>1</sup> at one end has passed beyond the edge of the port B<sup>3</sup>, and at the other end beyond the edge of the valve case; steam is therefore admitted to the port, both directly by the opening of the port to the steam supply, and by the opening of the apertures *b*<sup>3</sup>, at the exhaust end of the valve, so that steam will be admitted from both ends of the valve simultaneously.

As the ports B<sup>3</sup> extend around the valve, and the length of the port-opening is three times the diameter of the valve, and there being two such openings formed, it will be observed that a large quantity of steam will be admitted instantaneously at the end of each stroke, and that consequently the full pressure will be at once exerted on the piston. The essential difference between this valve and valves as heretofore constructed consists in supplying the steam in the centre of the valve, and surrounding the valve at all times with live steam, and in discharging the exhaust steam at the ends of the valve, thereby maintaining a uniform temperature in all parts of the valve and valve chest, which is not practicable with a valve having the capacity to supply the large quantity of steam as quickly as is done by this valve.

In figures 3, 4, and 5, K is a wheel secured to the main shaft of the engine, and preferably forming part of the fly-wheel H, placed on the side of the engine where the excentric I is located. The wheel K is provided with two studs, *k* *k*, on which the balance-weights *k*<sup>1</sup> *k*<sup>1</sup> are pivoted; these weights are held in their normal position by means of the spiral springs *k*<sup>2</sup> *k*<sup>2</sup>, which are arranged under such tension that at the desired speed of the engine they will counterbalance the centrifugal force of the weights *k*<sup>1</sup> *k*<sup>1</sup>. I is the main or valve-opening excentric; it is mounted upon the secondary excentric *l*, which is mounted upon the main shaft; the secondary excentric is movable angularly about the main shaft, and the valve-weights

*Improvements in Steam-engines.*

operating excentric is movable angularly about the secondary excentric in such a manner that, as the weights approach their centre of rotation under the action of their controlling springs, by reason of the engine running more slowly, the excentricities of the two excentrics will be partially added together, or lie toward the same side of the main shaft; but when the weights are most remote from their centre of the revolution, as is caused by an increase in the speed of the engine, the excentricities of the two excentrics will lie in opposite directions relative to the centre of movement of each, the centre of the main or valve-operating excentric, lying between the centre of the main shaft and that of the secondary excentric thus diminishing the throw of the main excentric to its minimum. By properly proportioning the excentricity, and governing the movement of the two excentrics, the lead-opening of the valve is maintained constant. To ensure this result and the accurate working of the two excentrics by properly connecting the same to the balance weight is the main object of this invention. The secondary excentric,  $l$ , is provided with two projections, and is connected with both the weights  $k^1 k^1$  by means of the links  $l^1 l^1$ , and at points equidistant from the pivots  $k k$ , while the main or valve-controlling excentric  $I$  is connected with one of the weights  $k^1$ , near the end of the weight furthest from the pivot, by the link  $l^2$ . The excentrics are by these means moved more rapidly and accurately, and are, therefore, more sensitive to any variation of speed, and will regulate the steam supply more perfectly, so as to maintain a fixed speed of the engine under any sudden variation of load, than when the two weights are connected by a link, as heretofore practised.

Another part of my invention is shown in figures 8 and 9. The object of this part of my invention is to bring the bearings of the main or crank shaft as close as possible to the line of the strain, or the centre line of the engine, and also to balance the crank and the connecting rod as near the line of the strain as possible, to prevent torsion. In carrying out this part of my invention, I make the shaft with two parallel discs and the connecting pin all in a single casting, preferably of steel. I then turn the shaft, the pin, and the discs, to give them a true surface, and I place balancing discs of a larger diameter on the crank-pin discs, and secure them in place by shrinking or otherwise. These large discs are concentric with the main shaft, and have their weight properly disposed to balance the momentum of the reciprocating parts when the engine is running. By this arrangement the crank-pin is rigidly connected with the main shaft, the crank and balancing discs run close to the connecting rod, and the bearing of the main shaft is brought very close to the plane of action of the actuating forces, the main shaft and its bearings being entirely relieved of all strain and torsion.  $L$  is the main shaft,  $N N$  are the crank-discs,  $M$  is the crank-pin, and  $G G$  are the balancing discs. The casting consisting of the shaft  $L$ , the discs  $N N$ , and the crank-pin  $M$  can be mounted in a lathe on the axis of the shaft, which can be turned to give it a true surface. It can also be mounted so as to turn the periphery of the discs  $N N$ , and then mounted on the axis of the pin  $M$ , when the same is also turned. The outer faces of the discs  $N N$  may be partly turned at either of the three different mountings, but the two inner faces must be turned or faced when mounted on the axis of the crank-pin. In order to balance the weight of the discs  $N N$ , the crank-pin  $M$ , the pitman, and other reciprocating parts of the engine relative to the main shaft, the balancing discs  $G G$ , consisting of a hub connected by a web, with the peripheral rim, are secured to the discs  $N N$ . These balancing discs  $G G$  have a portion cast hollow, forming a chamber, in which lead or other suitable material is placed to properly balance the unbalanced parts above mentioned, and these weights being placed between the pitman and the bearings of the shaft on the crank-discs, and on a line with the force exerted, relieve the shaft and bearings almost entirely from strain. The whole construction presents a pleasing and finished appearance.

Having thus fully described my said invention, and the manner of performing the same, I wish it understood that I claim—

First—In a steam-engine, the combination with the cylinder of a steam port centrally located, and exhaust ports located toward each end of two valve cylinders, and a piston valve extending into both the valve cylinders, having annular apertures near its ends, connected by a longitudinal passage through its interior, arranged relatively to the said steam port and exhaust ports, so that the live steam surrounds the said valve, and is delivered to the cylinder through the annular apertures in the valve, and directly from the live-steam chamber, simultaneously, substantially as described.

Second—The engine cylinder, and the steam and exhaust ports therein, combined with the valve cylinders, provided with annular depressions or port-openings entirely surrounding the valve, and the piston valve having annular apertures near its ends, connected by a longitudinal passage through the middle portion, which is of smaller external diameter than the bore of the valve cylinders, substantially as, and for the purpose, described.

Third—The combination, with the centrifugally-operating weights, of main and secondary excentrics, both actuated thereby, and both connected with the weights by links, the former near the end of the weights, and the latter near the pivotal connection, substantially as described.

Fourth—The combination with the crank shaft of the excentrics  $l$  and  $I$ , the weights  $k^1 k^1$ , the springs  $k^2 k^2$ , and the connecting links  $l^1 l^1$ , and  $l^2$ , constructed and arranged to control a steam-valve, substantially as, and for the purpose, described.

Fifth—In an engine, the herein-described crank-shaft, consisting of the shaft, discs, and crank-pin, all formed in a single piece; combined with independent balancing discs, mounted upon the said crank discs, substantially as described.

Sixth—The shaft, excentric cylindrical discs, and connecting crank-pin, all made of a single piece of metal, combined with balancing discs, mounted upon the said excentric discs, and having their peripheries concentric with the main shaft, substantially as described, and constructed to be mounted on the excentric discs, and provided with a chamber or chambers to receive heavy material for balancing the reciprocating parts, substantially as set forth.

In witness whereof, I, the said Pardon Armington, have hereto set my hand and seal, this second day of May, 1883.

PARDON ARMINGTON.

Witness—HENRY H. LAKE.

This

---

*Improvements in Steam-engines.*

---

This is the specification marked A referred to in the annexed Letters of Registration granted to Pardon Armington, this twenty-fifth day of August, A.D. 1883.

AUGUSTUS LOFTUS.

---

REPORT.

---

Sir, We do ourselves the honor to report, in reply to your B.C. of the 27th ultimo, No. 83-7,796, that we are of opinion that the prayer of Mr. Pardon Armington for the registration of an invention entitled "Improvements in Steam-engines" may be granted, in terms of his drawings and specification.

We have, &c.,

E. O. MORIARTY.  
JOHN WHITTON.

The Under Secretary of Justice.

---

[Drawings—two sheets.]

---

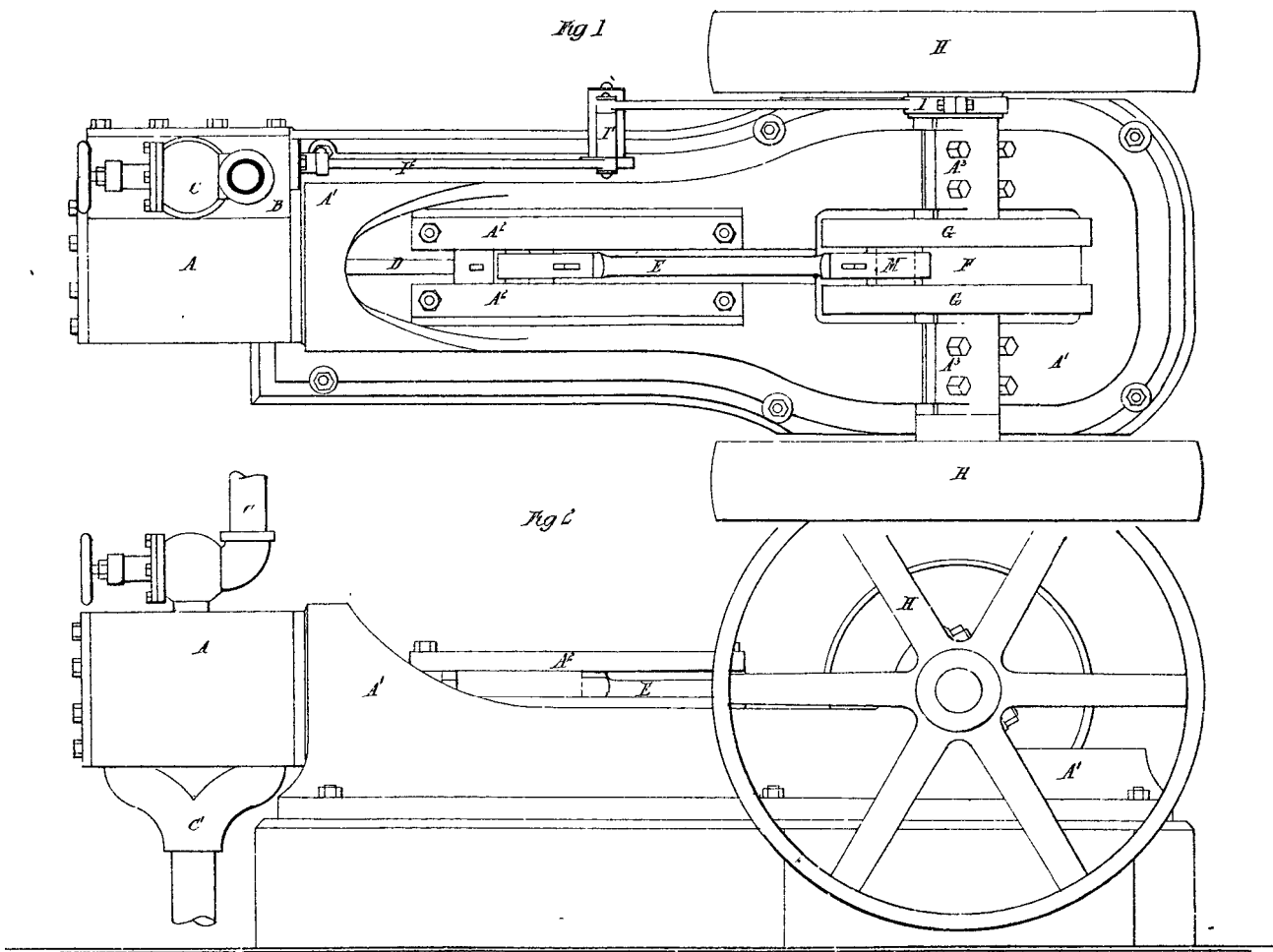
No. 1300.

[Assignment of No. 1294. See page 355.]



*B.*

1299.



*This is the Sheet of Drawings B. referred to in the annexed  
Letters of Registration granted to Pardon Armington this  
25<sup>th</sup> day of August A.D. 1883.*

*Augustus Loftus.*

PHOTO-LITHOGRAPHED AT THE GOVT. PRINTING OFFICE  
SYDNEY, NEW SOUTH WALES

*Sig 35.*

Fig. 3.

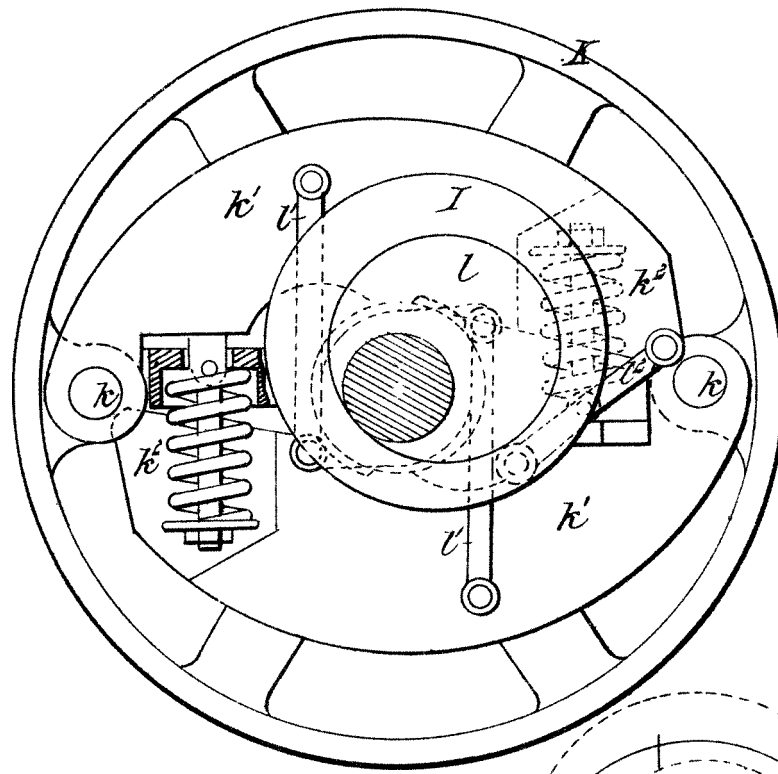


Fig. 4.

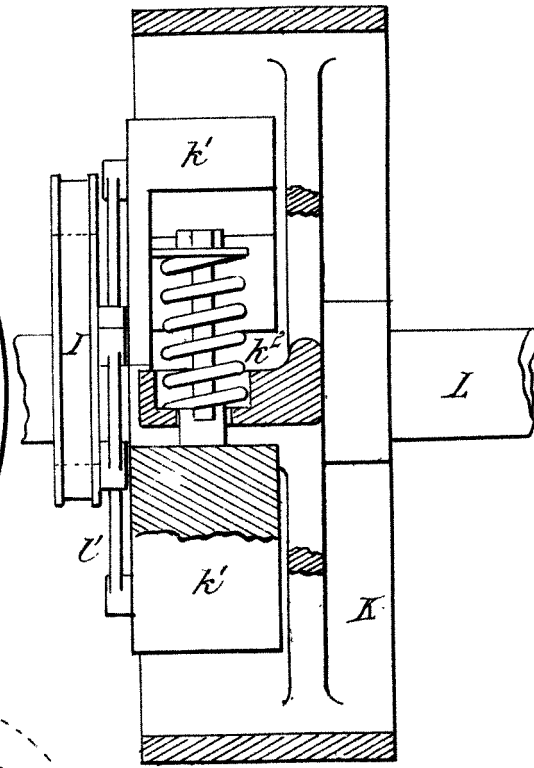


Fig. 6.

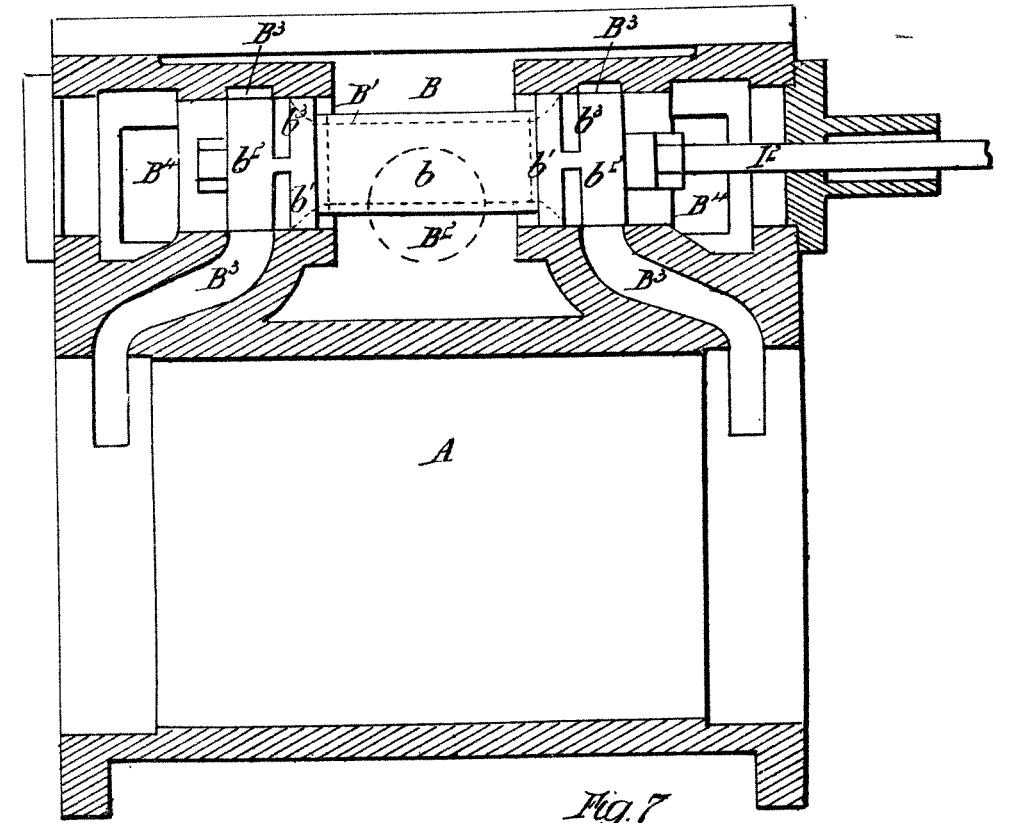


Fig. 5.

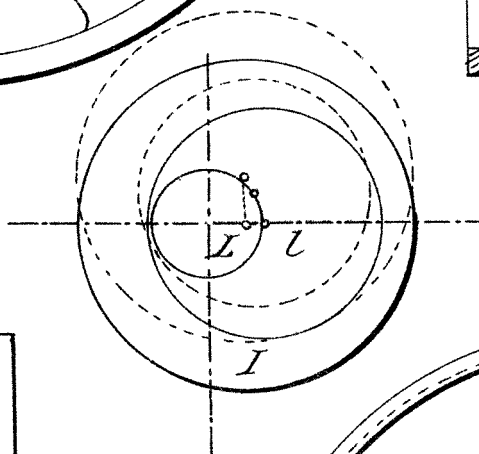


Fig. 9.

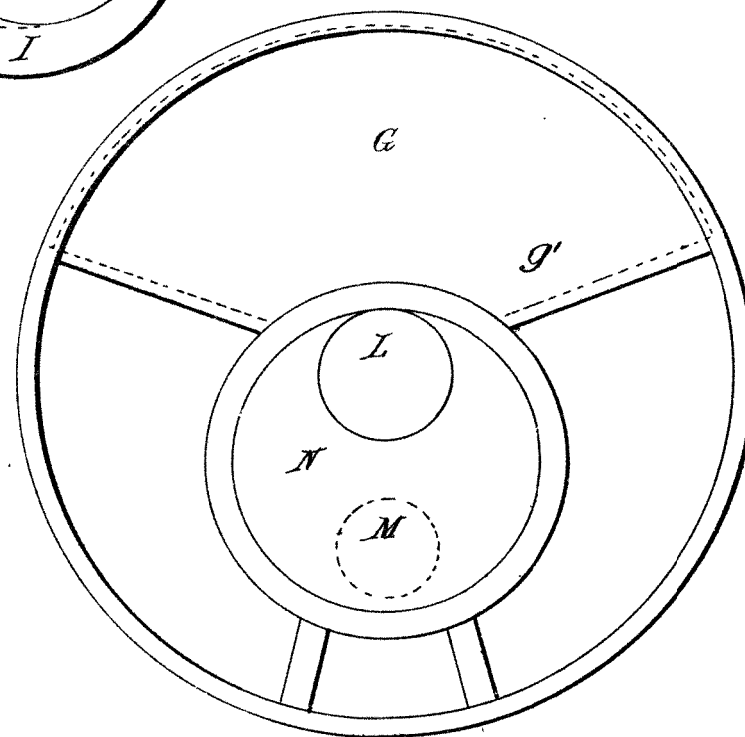


Fig. 8.

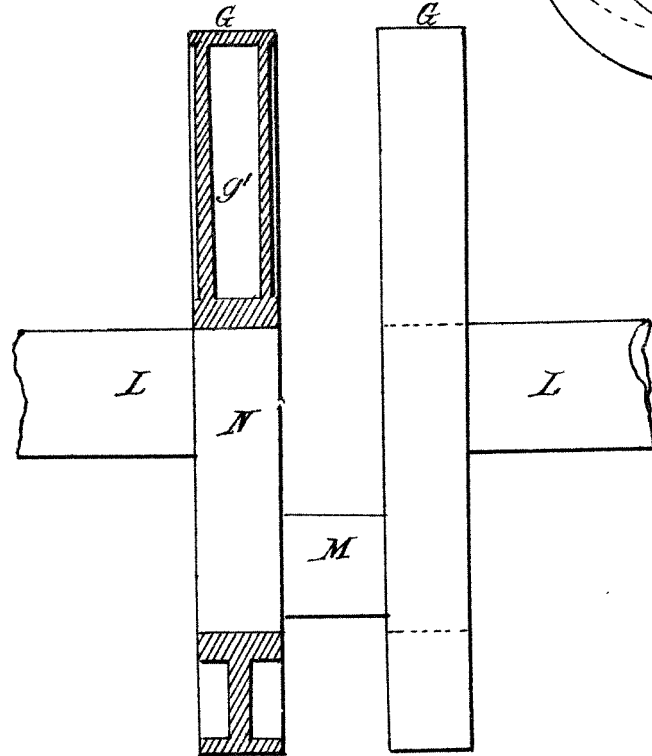
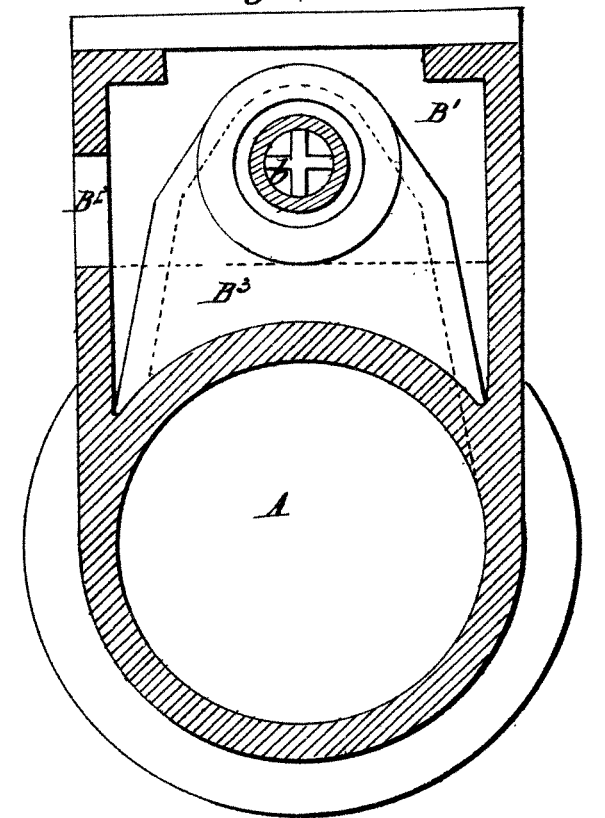


Fig. 7.



*This is the Sheet of Drawings marked C. referred to in the annexed Letters of Registration granted to Pardon Armington, this 25<sup>th</sup> day of August, A.D. 1883.*

*Augustus Loftus.*



A.D. 1883, 28th August. No. 1301.

**IMPROVEMENTS IN THE CONSTRUCTION OF TOOTHED AND PRONGED IMPLEMENTS, SUCH AS RAKES, HARROWS, COMBS, &c.**

LETTERS OF REGISTRATION to Alfred Holden, for Improvements in the construction of Toothed and Pronged Implements, such as Rakes, Harrows, Combs, &c.

[Registered on the 30th day of August, 1883, in pursuance of the Act 16 Vic. No. 24.]

BY HIS EXCELLENCY the RIGHT HONORABLE SIR AUGUSTUS WILLIAM FREDERICK SPENCER LOFTUS (commonly called LORD AUGUSTUS LOFTUS), Knight Grand Cross of the Most Honorable Order of the Bath, a Member of Her Majesty's Most Honorable Privy Council, Governor and Commander-in-Chief of the Colony of New South Wales and its Dependencies.

TO ALL TO WHOM THESE PRESENTS SHALL COME, greeting :

WHEREAS ALFRED HOLDEN, of Penshurst, near Gosford, in the Colony of New South Wales, gentleman, hath by his Petition humbly represented to me that he is the author or designer of a certain invention or improvement in manufactures, that is to say, of an invention entitled "Improvements in the construction of Toothed and Pronged Implements, such as Rakes, Harrows, Combs, &c.," which is more particularly described in the specification and the sheet of drawings which are hereunto annexed; and that he, the said Petitioner, hath deposited with the Honorable the Treasurer of the said Colony of New South Wales the sum of Twenty Pounds sterling, for defraying the expense of granting these Letters of Registration, as required by the Act of Council, sixteenth Victoria, number twenty-four; and hath humbly prayed that I would be pleased to grant Letters of Registration, whereby the exclusive enjoyment and advantage of the said invention or improvement might be secured to him for a period of fourteen years: And I, being willing to give encouragement to all inventions and improvements in the arts or manufactures which may be for the public good, and having received a report favourable to the prayer of the said Petition from competent persons appointed by me to examine and consider the matters stated therein and to report thereon for my information, am pleased, with the advice of the Executive Council, and in exercise of the power and authority given to me by the said Act of Council, to grant, and do by these Letters of Registration grant unto the said Alfred Holden, his executors, administrators, and assigns, the exclusive enjoyment and advantage of the said invention or improvement, for and during the term of fourteen years from the date hereof; to have, hold, and exercise unto the said Alfred Holden, his executors, administrators, and assigns, the exclusive enjoyment and advantage thereof, for and during and unto the full end and term of fourteen years from the date of these presents next and immediately ensuing, and fully to be complete and ended: Provided always that if the said Alfred Holden shall not, within three days after the granting of these Letters of Registration, register the same in the proper office in the Supreme Court, at Sydney, in the said Colony of New South Wales, then these Letters of Registration, and all advantages whatsoever hereby granted, shall cease and become void.

In witness whereof, I have hereunto set my sign manual, and have caused the present Letters of Registration to be sealed with the seal of the said Colony of New South Wales, at Government House, Sydney, in New South Wales, this twenty-eighth day of August, in the year of our Lord one thousand eight hundred and eighty-three.

[L.S.]

AUGUSTUS LOFTUS.

*Improvements in Toothed and Pronged Implements, &c.*

SPECIFICATION of ALFRED HOLDEN, of Penshurst, near Gresford, in the Colony of New South Wales, gentleman, for an invention entitled "Improvements in the construction of Toothed and Pronged Implements, such as Rakes, Harrows, Combs, &c."

My improvements in the construction of toothed and pronged implements, such as rakes, harrows, combs, &c., consist mainly in the addition thereto of a contrivance for cleaning or scraping the teeth of such implements as often as is found necessary. This contrivance I make in the form of a plate perforated with holes, corresponding in number and size to the number and size of the teeth to be cleaned. When not in actual use, this plate fits against the framing of the implement, and the teeth project through the holes therein; and when in use said plate is forced down to the point of the teeth, removing all matters adhering to them, and then is brought back again to its original position. I prefer to so bring it back by means of an elastic connection (which also forms a part of my invention), the tension of which is overcome when the plate is pressed towards the point of the teeth for cleaning them, and the resilient action of which brings it back again to its normal position when relieved of such pressure.

Referring to my drawings, figure 1 is a front view of a hand-rake, constructed according to my invention, and with the cleaner in its normal position; figure 2 is end view of same; figure 3 is a similar view to figure 1, but with the cleaner forced down to the point of the teeth; figures 4 and 5 are sections on lines *a a* and *b b* respectively, in figure 3. *A* is the rake frame, and *B* the teeth or tines; *C* the sliding plate or cleaner, having a lug *C'* at each end. The elastic connection, in this case, consists of india rubber rings or bands *D*, which embrace the frames *A* and the plate *C'*. These rings are put on over the lugs *C'*, and stretched over the end teeth. When the teeth or tines become clogged it is only necessary to turn over the rake and strike lugs *C'* upon the ground with sufficient force to drive the cleaner plate to the point of the teeth, in the doing of which it will remove all weeds and earth, and then the elastic bands *D* will bring it back again to its normal position, after the force of the blow has been expended.

Figure 6 is a plan of a common harrow, also constructed according to my invention, and figure 7 is a sectional elevation on line *c c* in figure 6, the cleaner being, as before, in its normal position. *A* is the frame, *B* the teeth or tines, and *C* the cleaner plate. The elastic connection, in this case, consists of spiral springs *D*. *C'* are bolts from the cleaner through the frame *A* to bars *C''*. The action in this case is similar to that before described, it being only necessary to turn the harrow on its back, when its own weight will compress the springs *D* and force the cleaner plate *C'* upwards, removing the dirt and weeds adhering to the teeth. When this has been done, the harrow is turned over again, and the springs *D* return the cleaner plate to its normal position.

It will be noticed that the holes in this cleaner plate are of a size just sufficient to allow the teeth to pass through, and so to admit of the plate resting against the frame, and that the plate is allowed to slide just so far that its outer side is clear of the points of the teeth, but no farther. Many other means of elastically connecting the cleaner to the frame will suggest themselves, but for small implements I prefer to use india rubber bands, and for larger ones one or more springs, as shown.

Having thus particularly described and ascertained the nature of my invention, and the manner in which it is to be performed, I would have it understood that I do not confine myself to any particular means of elastically connecting my cleaner plate to the implement, so long as the nature of my invention be retained; but what I claim as my improvement in the construction of toothed and pronged implements, such as rakes, harrows, combs, &c., is,—

First—The addition to, or combination with, such implements of a perforated cleaner plate to be worked up and down the teeth, for the purpose of cleaning them, substantially as described.

Second—The elastic connection for connecting such cleaner plate to the body or frame of the implement, so as to return said plate to its normal position when relieved of the pressure which forces it forward, substantially as described.

In witness whereof, I, the said Alfred Holden, have hereto set my hand and seal, this second day of July, one thousand eight hundred and eighty-three.

ALFRED HOLDEN.

Witness—  
H. H. HOLDEN.

This is the specification referred to in the annexed Letters of Registration granted to Alfred Holden, this 28th day of August, A.D. 1883.

AUGUSTUS LOFTUS.

### REPORT.

Sir,

In accordance with your B.C. minute of the 7th instant, forwarding for report a Petition from Alfred Holden for Letters of Registration for an invention entitled "Improvements in the construction of Toothed and Pronged Implements, such as Rakes, Harrows, Combs, &c.," we have to report that we are of opinion such Letters might issue.

We have, &c.,

JAMES BARNET.  
WILLIAM C. BENNETT.

The Under Secretary of Justice.

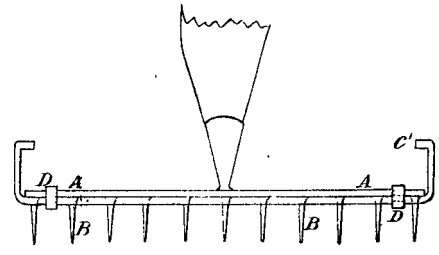


Fig. 1.

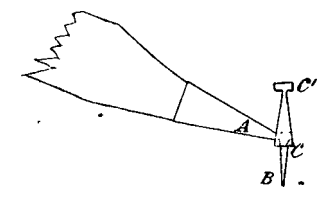


Fig. 2.

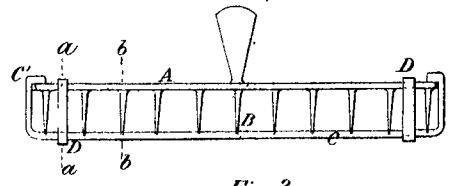


Fig. 3.



Fig. 4.



Fig. 5.

*This is the Sheet of Drawings referred to in the annexed  
 letters of Registration granted to Alfred Holden, this  
 28<sup>th</sup> day of August A. D. 1883.  
 Augustus Loftus.*

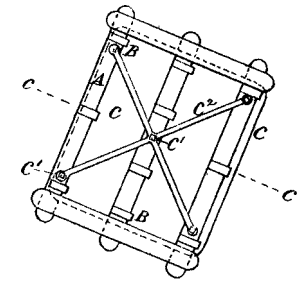


Fig. 6.

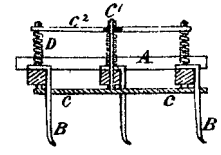


Fig. 7.



A.D. 1883, 28th August. No. 1302.

IMPROVEMENTS IN PUMPS FOR THE EXTRACTION OF NIGHT-SOIL FROM  
CESSPITS.

LETTERS OF REGISTRATION to Ernest Sydney Burman, for an Invention for removing night-soil and other matters in a fluid or semi-fluid state, from cesspits or other places, to receptacles for the same, and during the process of such removal disinfecting and rendering all noxious gases therefrom inodorous.

[Registered on the 30th day of August, 1883, in pursuance of the Act 16 Vic. No. 24.]

BY HIS EXCELLENCY THE RIGHT HONORABLE SIR AUGUSTUS WILLIAM FREDERICK SPENCER LOFTUS (commonly called LORD AUGUSTUS LOFTUS), Knight Grand Cross of the Most Honorable Order of the Bath, a Member of Her Majesty's Most Honorable Privy Council, Governor and Commander-in-Chief of the Colony of New South Wales and its Dependencies.

TO ALL TO WHOM THESE PRESENTS SHALL COME, greeting :

WHEREAS ERNEST SYDNEY BURMAN, Moore Park Road, Sydney, in the Colony of New South Wales, Civil Engineer, hath by his Petition humbly represented to me that he is the author or designer of a certain invention or improvement in manufactures, that is to say, of an invention entitled "A pump for the extraction of Night-soil and other matters in a fluid or semi-fluid state from cesspits or other places to receptacles for the same, and during the process of such removal disinfecting and rendering all noxious gases therefrom inodorous," which is more particularly described in the specification and the sheet of drawings which are hereunto annexed; and that he, the said Petitioner, hath deposited with the Honorable the Treasurer of the said Colony of New South Wales the sum of Twenty Pounds sterling, for defraying the expense of granting these Letters of Registration as required by the Act of Council sixteenth Victoria, number twenty-four, and hath humbly prayed that I would be pleased to grant Letters of Registration whereby the exclusive enjoyment and advantage of the said invention or improvement might be secured to him for a period of fourteen years. And I being willing to give encouragement to all inventions and improvements in the arts or manufactures which may be for the public good, and having received a report favourable to the prayer of the said Petition from competent persons appointed by me to examine and consider the matters stated therein, and to report thereon for my information, am pleased, with the advice of the Executive Council, and in exercise of the power and authority given to me by the said Act of Council, to grant, and do, by these Letters of Registration, grant unto the said Ernest Sydney Burman, his executors, administrators, and assigns, the exclusive enjoyment and advantage of the said invention or improvement for and during the term of fourteen years from the date hereof, to have, hold, and exercise unto the said Ernest Sydney Burman, his executors, administrators, and assigns, the exclusive enjoyment and advantage thereof, for and during and unto the full end and term of fourteen years from the date of these presents next and immediately ensuing and fully to be complete and ended. Provided always that if the said Ernest Sydney Burman shall not, within three days after the granting of these Letters of Registration register the same in the proper office in the Supreme Court, at Sydney, in the said Colony of New South Wales, then these Letters of Registration, and all advantages whatsoever hereby granted, shall cease and become void.

In witness whereof, I have hereunto set my sign manual, and have caused the present Letters of Registration to be sealed with the seal of the said Colony of New South Wales, at Government House, Sydney, in New South Wales, this twenty-eighth day of August, in the year of our Lord one thousand eight hundred and eighty-three.

AUGUSTUS LOFTUS.

SPECIFICATION

*Improvements in Pumps for the Extraction of Night-soil from Cesspits.*

SPECIFICATION of an invention by ERNEST SYDNEY BURMAN, of Sydney, New South Wales, for the purpose of removing night-soil and other matters in a fluid or semi-fluid state from cesspits or other places, to receptacles for the same, and during the process of such removal disinfecting and rendering all noxious gases therefrom inodorous.

HEREINUNDER the machinery and appliances for the abovementioned purpose are fully and particularly described, and reference made to the drawings of the same in explanation thereof.

An oscillating cylinder A (figures 1, 2, 3) turns on a centre B (figure 3), situated anywhere in its length, as may be most convenient. The piston P (figures 1, 3), have through piston rods, *p* 1, *p* 2 (figure 1), one of which is connected at C 1 (figure 1) with an arm D (figures 1, 2). This arm is connected to the main shaft or rocking shaft F (figures 1, 2, 3), at Q<sup>1</sup>, or any other convenient point. From this shaft the motion is imparted to the machine. This rocking shaft has its centre at E (figures 1, 2, 3), or any other convenient point, according to the arc to be described.

Handles are attached at R<sup>1</sup>, R<sup>2</sup> (figure 1), at which point the power is applied. The bearings B (figures 3), on which the cylinder A turns, are hollow, and a pipe (figure 3), leading through on either side of the airway, forms a connection for the connections *f*<sup>1</sup> *f*<sup>2</sup> (figures 2, 3).

Placed at any distance convenient is the fire or box N (figures 1, 2, 4), in which the gases are consumed, and from the fire N, is also drawn the smoke and vapour for deodorizing the pipes, &c., after use. Also situated at any convenient distance from the pump is the tank T (figures 1, 2), or other convenient receptacle, into which the soil or spoil, &c., is drawn, and which is provided with air-tight caps or covers, *t*<sup>1</sup> *t*<sup>2</sup>, at the holes at which the insertion of the pipes take place.

At *u* (figures 1, 2), on the tube S (figures 1, 2), is situated the tell-tale valve, which is formed of a leather washer or other convenient substance, and acts so that when the soil, spoil, &c., in the tank rises it closes the aperture, and cuts off communication with the pump, thereby stopping the machine.

The other end of tube S is fixed at L<sup>1</sup> (figures 1, 2), on the pump.

At L<sup>2</sup> (figures 1, 2), on the pump, is fixed the tube V (figures 1, 2). The other end of this tube is connected to the box or fire N, at Z (figs. 1, 2, 4), or when deodorizing pipes and connections at P (figs. 1, 2, 4).

In the fire or box N, is burned chopped straw and coal, on to which is placed mustard, sulphur, or other substances. This fire is kept alight by the foul air and gases passing from the tank T through the tubes to the fire N.

The suction-hose M (figures 1, 2) is connected with the tank T, or other receptacle, and the other end is led down the pit or other store place from which the soil or spoil, &c., is to be drawn. Through this hose M the soil passes to the tank T, or other receptacle, A. At foot of hose M, at *g*<sup>1</sup> (figures 1, 2), is an iron strainer, to prevent the choking of the pipe by large or foreign matter.

A cock O (figure 1), is fixed at the bottom of the tank T, or other receptacle, which is the ejection cock for the night-soil or other spoil, and by reversing the couplings of the flexible tubes, *i.e.*, by connecting tube V at pump coupling of tube S, and by connecting tube S at pump coupling of tube V, the pump becomes a force pump instead of suction. On working the machine the air is forced on to the top of the soil or spoil in the tank T, or other receptacle, and it is ejected; at the same time the tank and connections are deodorized.

The actions of the machine and its connections are these—That on starting the pump with the flexible tubes coupled as shown in drawings, the air is exhausted from the tank T, or other receptacle, and the soil or spoil, &c., rushes up the suction hose M, and fills the tank until it arrives at the level of the valve *u*, which closes and stops the machine operating. The air and foul gases as they are exhausted from the tank are drawn through the tube S and pump, and forced through the tube V to the fire or box N, where combustion takes place, thus rendering the operation odourless.

After the work of filling the tank, &c., is completed, and the connections, &c., are to be deodorized, the connections on the tubes S and V are reversed, *i.e.*, by connecting tube V at pump coupling of tube S, and by connecting tube S at pump coupling of tube V, and by coupling the fire end of tube V at P instead of Z, the pump becomes a force pump instead of suction. The smoke and vapour is forced through the pipes and tank into the pit, &c., and the whole is deodorized accordingly.

This invention also provides for the use of any convenient mechanism in connection with the cylinder or appliances thereto.

Having described the nature of my invention, and the manner of performance of such invention, I claim to be protected the application and employment of a cylinder and suitable mechanism, as described, or other motion imparted to a cylinder, the employment of a tank or other receptacle wherefrom to exhaust the air and foul gases for the reception of night-soil, spoil, &c., the combustion of the gases by the means named, and the use of all the connections, &c., by the invention to complete it as one machine for the purposes herein named, *i.e.*, the extraction of night-soil, &c., from pits, &c., the same extraction being accomplished by the suction pump and connection as herein described, and shown on drawings 1, 2, 3, 4, or in reverse for ejection purposes only, a force pump. The pump, connections, &c., to make up one complete machine, for the purposes herein named.

In testimony of which invention, I hereunto set my hand.

Witnesses—W. HENRY REES.

W. H. WARREN, C.E.

ERNEST SYDNEY BURMAN.

This is the specification referred to in the annexed Letters of Registration granted to Ernest Sydney Burman, this 28th day of August, A.D. 1883.

AUGUSTUS LOFTUS.

### REPORT.

Sir,

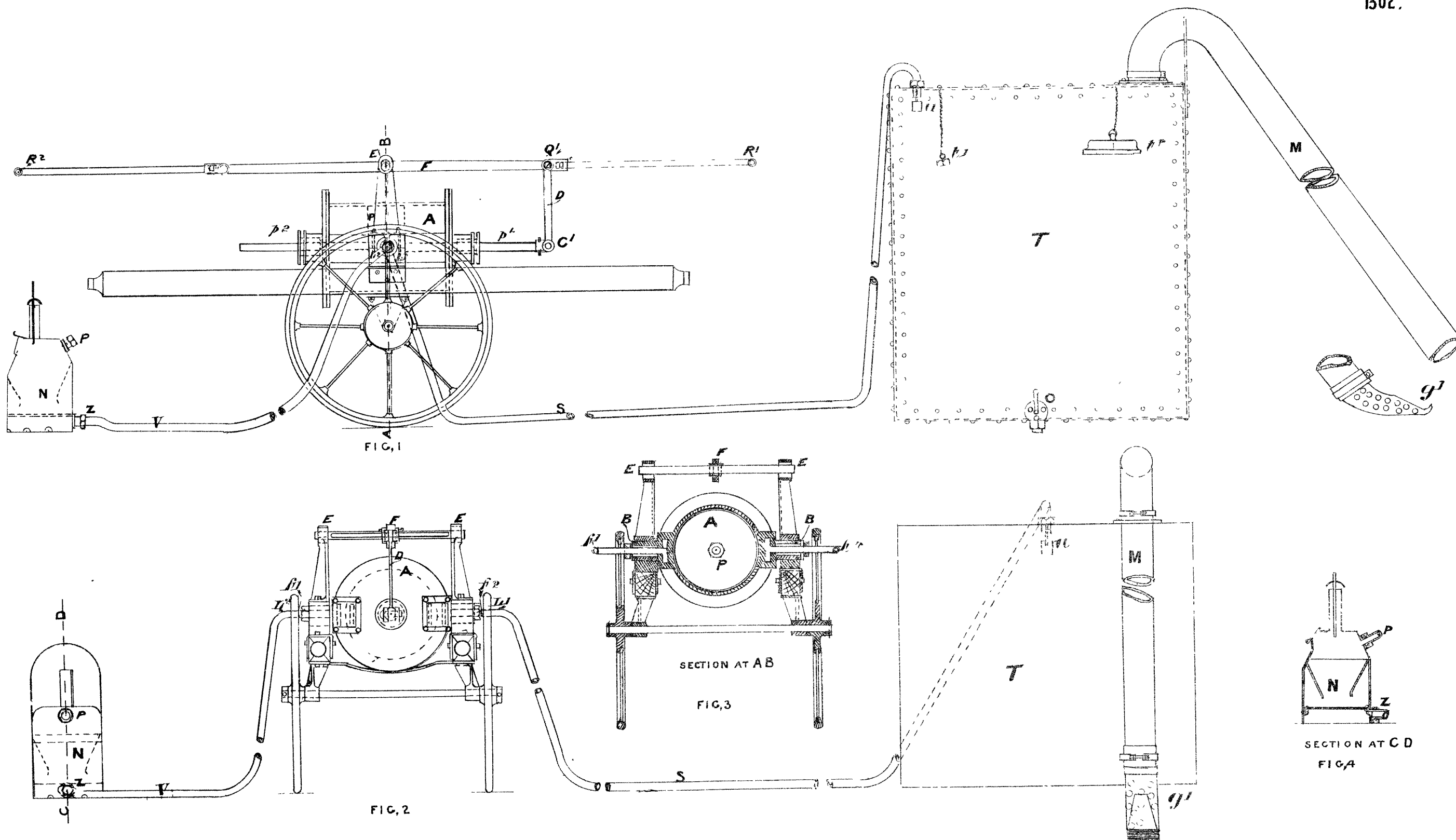
In accordance with your B.C. minute of the 11th instant, forwarding for report a Petition from Ernest Sydney Burman for Letters of Registration for an invention entitled "Improvements in Pumps for the extraction of night-soil from cesspits," we have to report that we are of opinion such Letters might issue.

We have, &c.,

JAMES BARNET.

WILLIAM C. BENNETT.

The Under Secretary of Justice.



*This is the Sheet of Drawings referred to in the annexed  
 Letters of Registration granted to Ernest Sydney Barman,  
 this twenty eighth day of August, A. D. 1883.*

*Augustus Loftus.*

*Henry J. Warren, C.E.*

*Inventor  
 Ernest Sydney Barman  
 (Sig. 35.)*





A.D. 1883, 28th August. No. 1303.

**AN IMPROVEMENT IN AN EXPLOSIVE COMPOUND AND ITS USE IN THE ART OF BLASTING AND FOR OTHER PURPOSES.**

**LETTERS OF REGISTRATION** to Silas Reynolds Divine, for an Improvement in an explosive compound and its use in the art of Blasting and for other purposes.

[Registered on the 30th day of August, 1883, in pursuance of the Act 16 Vic. No. 24.]

BY HIS EXCELLENCY THE RIGHT HONORABLE SIR AUGUSTUS WILLIAM FREDERICK SPENCER LOFTUS (commonly called LORD AUGUSTUS LOFTUS), Knight Grand Cross of the Most Honorable Order of the Bath, a Member of Her Majesty's Most Honorable Privy Council, Governor and Commander-in-Chief of the Colony of New South Wales and its Dependencies.

TO ALL TO WHOM THESE PRESENTS SHALL COME, greeting:

WHEREAS SILAS REYNOLDS DIVINE, chemist, of Loch Sheldrake, Sullivan County, New York, United States of America, hath by his Petition humbly represented to me that he is the author or designer of a certain invention or improvement in manufactures, that is to say, of an invention entitled "An improvement in an explosive compound and its use in the art of Blasting and for other purposes," which is more particularly described in the specification which is hereunto annexed; and that he, the said Petitioner, hath deposited with the Honorable the Treasurer of the said Colony of New South Wales the sum of Twenty Pounds sterling, for defraying the expense of granting these Letters of Registration, as required by the Act of Council, sixteenth Victoria, number twenty-four; and hath humbly prayed that I would be pleased to grant Letters of Registration, whereby the exclusive enjoyment and advantage of the said invention or improvement might be secured to him for a period of fourteen years: And I, being willing to give encouragement to all inventions and improvements in the arts or manufactures which may be for the public good, and having received a report favourable to the prayer of the said Petition, from competent persons appointed by me to examine and consider the matters stated therein and to report thereon for my information, am pleased, with the advice of the Executive Council, and in exercise of the power and authority given to me by the said Act of Council, to grant, and do by these Letters of Registration grant unto the said Silas Reynolds Divine, his executors, administrators, and assigns, the exclusive enjoyment and advantage of the said invention or improvement, for and during the term of fourteen years from the date hereof; to have, hold, and exercise unto the said Silas Reynolds Divine, his executors, administrators, and assigns, the exclusive enjoyment and advantage thereof, for and during and unto the full end and term of fourteen years from the date of these presents next and immediately ensuing, and fully to be complete and ended: Provided always, that if the said Silas Reynolds Divine shall not, within three days after the granting of these Letters of Registration, register the same in the proper office in the Supreme Court, at Sydney, in the said Colony of New South Wales, then these Letters of Registration, and all advantages whatsoever hereby granted, shall cease and become void.

In witness whereof, I have hereunto set my sign manual, and have caused the present Letters of Registration to be sealed with the seal of the said Colony of New South Wales, at Government House, Sydney, in New South Wales, this twenty-eighth day of August, in the year of our Lord one thousand eight hundred and eighty-three.

AUGUSTUS LOFTUS.

*Improvement in an explosive compound and its use in the art of Blasting.*

## SPECIFICATION.

TO ALL WHOM IT MAY CONCERN, be it known that I, SILAS REYNOLDS DIVINE, of Loch Shel-drake, in the County of Sullivan, and State of New York, U. S. A., have invented a certain invention, entitled "An improvement in an explosive compound and its use in the art of Blasting and for other purposes," of which the following is a full, clear, and exact specification.

It is the object of my invention to provide for employment, chiefly in blasting operations, a high explosive, the ingredients of which can be separately manufactured, handled, and transported, and can be mechanically united, when required for use, by the consumer, whereby the danger usually attending the manufacture, handling, and transportation of ordinary high explosives is avoided.

To this end I have invented an explosive compound composed of two inexplusive ingredients, the one a solid, such as crushed or powdered chlorate of potash, and the other a liquid, such as nitrate of benzole, which are combined to form a high explosive, by merely causing the mass of the solid ingredient to absorb the liquid ingredient, a combination of which can be effected by the consumer at the time when, and at the place where, the explosive is to be used. These ingredients, being in themselves incapable of being exploded by percussion, can be, with safety, separately manufactured, handled, and transported to the consumer, who will readily effect their combination.

Either perchlorate or permanganate of potash may be used as the solid ingredient, and other liquid nitro-compounds may be substituted for the nitro-benzole, the essential condition being observed that the liquid ingredient substituted shall possess a degree of fluidity, which shall adapt it to be readily absorbed by the solid ingredient, so that the final act of preparing the explosive for use may be performed by merely bringing the two ingredients into juxtaposition, and allowing the liquid ingredient to be absorbed by the solid ingredient.

In manufacturing my nitro-benzole I use the naphtha of commerce, and it will therefore be understood that my nitro-benzole contains some nitro-tolual and picric acid.

Four and one-sixth parts of chlorate of potash to one part of nitro-benzole I consider to constitute the theoretical proportions in which the ingredients of my compound combine most effectively; but in order to somewhat diminish the sensitiveness of the compound to ignition by percussion, I prefer to use from three to not exceeding four parts of chlorate of potash to one part of nitro-benzole.

My invention further consists in constructing cartridge-shells or envelopes, preferably of muslin, cloth, paper, or other porous material, and in filling such shells with the solid ingredient of my explosive, and in providing the liquid ingredient in a separate vessel for transportation, so that finally when the cartridge is required for use the consumer effects the necessary combination of the ingredient by causing the solid ingredient to absorb the liquid ingredient either by immersing the cartridge-shell in the liquid ingredient or by opening one end of the cartridge and slowly pouring the liquid ingredient upon the solid ingredient contained in the cartridge-shell. Although the proportions of the two ingredients may be varied without materially affecting the efficiency of the explosive, it may be desirable in some cases that exact proportions should be adhered to, and therefore in practice there may be provided, for use when desired, separate packages or bottles, each containing the quantity of nitro-benzole required for the amount of chlorate of potash contained in a single cartridge.

It will thus be seen that my cartridge-shell is prepared for transportation by being charged with a solid ingredient, which, by reason of its not being explosive, can be safely handled and transported, the completion of the charge being effected by the consumer at the time when the cartridge is required for use, by merely adding the required quantity of the liquid ingredient to the solid ingredient.

By means of my porous cartridge-envelope the relative proportions of the ingredients of my compound may be conveniently fixed, with suitable accuracy, by first allowing the solid ingredient to become fully saturated with the liquid ingredient, and then squeezing or wringing out the cartridge by hand.

As soon as the ingredients of my explosive compound are mechanically united, as set forth, the cartridge is ready for use, and may, if desired, be at once inserted in the drill-hole and exploded by percussion. It will, of course, be understood that the ingredients of my compound may, if desired, be mixed in measured proportions and in any convenient vessel.

Owing to the viscous condition assumed by my explosive compound, when the ingredients are united, it is not liable to be accidentally exploded by tamping in the act of charging the drill-hole, and in this respect possesses an important advantage greatly contributing to safety in its employment.

As nitro-benzole is not miscible with water, my solid ingredient and my porous cartridge-envelope, by the absorption of nitro-benzole, become water-repellant, and my cartridge is thus specially adapted for blasting in water.

What I claim as my invention is:—

1. The explosive compound herein described, which consists of a solid ingredient, such as chlorate of potash, and a liquid ingredient, such as nitro-benzole, mechanically united substantially in the proportions of from three to four and one-sixth parts of the solid ingredient to one part of the liquid ingredient, substantially as and for the purpose set forth.
2. The improvement in the art of blasting herein described, which consists in preparing an explosive compound from an inexplusive solid ingredient, such as crushed or powdered chlorate of potash, and an inexplusive liquid ingredient, such as nitro-benzole, by depositing prescribed quantities of the solid ingredient in cylindrical cartridges or envelopes made of cloth, paper, or other porous material, and in immersing the envelopes containing the solid ingredient in the liquid ingredient, or otherwise saturating the solid ingredient and its envelope with the liquid ingredient preparatory to depositing the cylindrical envelope or cartridge in the drill-hole and igniting it with an exploder, or by any other of the usual means.

---

*Improvement in an explosive compound and its use in the art of Blasting.*

---

3. The improved blasting cartridge herein described, which consists of a cylindrical cartridge or envelope made of cloth, paper, or other porous material, containing a solid substance, such as crushed or powdered chlorate of potash, or its equivalent, which, with its envelope, is saturated with a liquid, such as nitro-benzole, or its equivalent, substantially in the manner and for the purpose set forth.

SILAS REYNOLDS DIVINE.  
(By his Agent, EDWARD WATERS.)

This is the specification referred to in the annexed Letters of Registration granted to Silas Reynolds Divine, this twenty-eighth day of August, A.D. 1883.

AUGUSTUS LOFTUS.

---

**REPORT.**

---

Sir,

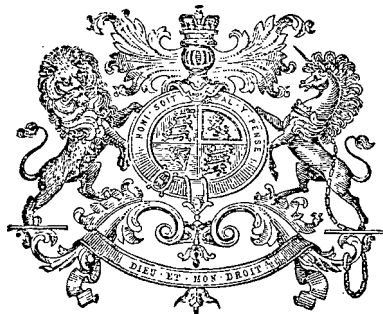
Sydney, 23 July, 1883.

In accordance with your B.C. minute of the 14th instant, forwarding for report the petition of Mr. Silas Reynolds Divine for Letters of Registration for an invention entitled "An improvement in an explosive compound and its use in the art of Blasting and for other purposes," we have to report that we are of opinion such Letters might be issued.

We have, &c.,

JAMES BARNET.  
WILLIAM C. BENNETT.

The Under Secretary of Justice.



A.D. 1883, 28th August. No. 1304.

IMPROVEMENTS IN COUPLING FOR TUBING.

LETTERS OF REGISTRATION to Edmund Coggsell Converse, for improvements in Couplings for Tubing.

[Registered on the 30th day of August, 1883, in pursuance of the Act 16 Vic., No. 24.]

BY HIS EXCELLENCY THE RIGHT HONORABLE SIR AUGUSTUS WILLIAM FREDERICK SPENCER LOFTUS (commonly called LORD AUGUSTUS LOFTUS), Knight Grand Cross of the Most Honorable Order of the Bath, a Member of Her Majesty's Most Honorable Privy Council, Governor and Commander-in-Chief of the Colony of New South Wales and its Dependencies.

TO ALL TO WHOM THESE PRESENTS SHALL COME, greeting:

WHEREAS EDMUND COGGSWELL CONVERSE, of Pittsburgh, in the County of Allegheny, and State of Pennsylvania, in the United States of America, hath by his Petition humbly represented to me that he is the author or designer of a certain invention or improvement in manufactures, that is to say, of an invention entitled "Improvements in Couplings for Tubing," which is more particularly described in the specification and the sheet of drawings which are hereunto annexed; and that he, the said Petitioner, hath deposited with the Honorable the Treasurer of the said Colony of New South Wales the sum of Twenty Pounds sterling, for defraying the expense of granting these Letters of Registration, as required by the Act of Council, sixteenth Victoria, number twenty-four; and hath humbly prayed that I would be pleased to grant Letters of Registration, whereby the exclusive enjoyment and advantage of the said invention or improvement might be secured to him for a period of fourteen years: And I, being willing to give encouragement to all inventions and improvements in the arts or manufactures which may be for the public good, and having received a report favourable to the prayer of the said Petition, from competent persons appointed by me to examine and consider the matters stated therein and to report thereon for my information, am pleased, with the advice of the Executive Council, and in exercise of the power and authority given to me by the said Act of Council, to grant, and do by these Letters of Registration grant unto the said Edmund Coggsell Converse, his executors, administrators, and assigns, the exclusive enjoyment and advantage of the said invention or improvement, for and during the term of fourteen years from the date hereof; to have, hold, and exercise unto the said Edmund Coggsell Converse, his executors, administrators, and assigns, the exclusive enjoyment and advantage thereof, for and during and until the full end and term of fourteen years from the date of these presents next and immediately ensuing, and fully to be complete and ended: Provided always, that if the said Edmund Coggsell Converse shall not, within three days after the granting of these Letters of Registration, register the same in the proper office in the Supreme Court, at Sydney, in the said Colony of New South Wales, then these Letters of Registration, and all advantages whatsoever hereby granted, shall cease and become void.

In witness whereof, I have hereunto set my sign manual, and have caused the present Letters of Registration to be sealed with the seal of the said Colony of New South Wales, at Government House, Sydney, in New South Wales, this twenty-eighth day of August, in the year of our Lord one thousand eight hundred and eighty-three.

[L.S.]

AUGUSTUS LOFTUS.

*Improvements in Couplings for Tubing.*

SPECIFICATION of EDMUND COGGSWELL CONVERSE, of Pittsburgh, in the County of Allegheny, and State of Pennsylvania, in the United States of America, for an invention entitled "Improvements in Couplings for Tubing."

MY invention relates to couplings for metal tubing, its object being to form a coupling whereby the several lengths of tubing can be connected without cutting into and weakening the tubing, as is the case where they are connected by screw-threaded couplings or sockets. Where a screw thread is cut into the metal tubing it is so weakened at the part threaded that to enable this part to withstand the necessary internal pressure, or any longitudinal strain, or lateral or bending strain, the tubing is formed much thicker than is necessary for the unthreaded portion of the tubing.

It is evident that this increased thickness of the tubing necessarily increases not only its cost, but, on account of its increased weight, also adds much to the expense of transportation. For this reason a coupling by which the lighter metal tubing can be securely connected, so as to withstand not only the internal pressure of the water or other liquid, compressed air, or gas, confined in or passing through it, but also any longitudinal strain, consequent to the expansion and contraction of the tubing, or lateral bending strain, is much sought after.

Another object of my invention is, to form a coupling wherein the interior face of the tubing and coupling are even, and the inner surface of the line of tubing is smooth, thus doing away with the friction found in the ordinary couplings, on account of the ends of the tubing not meeting each other, side currents being formed in the fluid passing through the tubing at each joint. My invention consists, first, in a coupling collar or sleeve for tubing having an inner central ring and annular calking recess at each end for the reception of lead or other calking or packing material, said calking recesses having inwardly flaring sides to hold the calking material more securely in place, and enable it to withstand—without displacement—any internal pressure from the fluid in the tubing; second, in combining with tubing having one or more lugs or similar connecting devices this coupling collar or sleeve, provided on the interior with a central ring against which the ends of the tubing butt or bear, proper seats or recesses on either side of said ring within which the lugs on the tubing engage, and annular calking recesses at each end beyond such seats or recesses whereby after the connection between the tubing and collar has been effected the annular recesses may be filled and calked or packed, and the calking material will lock the lugs in their seats and surround the tubing above the locking devices; and finally, in forming the inner faces on each side of the central ring of the collar, tapering so as to compress or "bind" around the end of the tubing, and round it up to proper shape if its edges become bent in transportation or handling. To enable others skilled in the art to make and use my invention I will describe its construction and manner of use, referring for that purpose to the accompanying drawings, in which figure 1 is a sectional view of the coupling collar, showing one tube connected therein, and the other tube in full lines ready to enter the collar; figure 2 is a cross-section on the line *x-x*, figure 1; figure 3 is a perspective view partly broken away of the coupling collar; figure 4 is a longitudinal section of the tubing, showing the connecting lugs expanded from the body of the tubing; and figure 5 is a sectional view, illustrating another form of coupling collar. Like letters of reference indicate like parts in each.

The coupling collar or sleeve *A* is preferably cast to shape, though it may be rolled or forged, and turned, if desired. It is preferably provided with the annular ring or projection *b*, midway between the ends, so as to form on either side of it an annular shoulder, against which the ends of the tube sections *C C* butt or bear. The ring is made the same height as the thickness of the metal in the tubing, so that a smooth interior is obtained for the passage of the fluid to be connected, and no opportunity is afforded for the pressure of the fluid directly against the ends of the tubing. By having the inner surface smooth or flush, as above described, the friction of the fluid in passing through the coupling is entirely overcome, and practical experience shows that from ten to twenty-five per centum less power is required to force the fluid through a line of tubing thus connected than when the ends of the tubing do not meet, and consequently form an annular space in the coupling between the ends of the tubing by which "riffles" or side currents are formed. The inner faces *d* of the collar extend out a sufficient distance on either side of the central ring *b* to give a strong brace to the ends of the tubing, around which they fit neatly, being preferably formed slightly tapering, so as to compress or bind the ends of the tubing around their entire circumference, thus rounding up the tubing if bent out of shape, and enabling the body of the collar to support it against internal pressure strain. These inner faces may be divided into sections if so desired. Between these inner faces, *d*, and the ends of the collar are the annular calking recesses *f*, for the reception of the lead or other calking material, these calking recesses being preferably formed inwardly flaring, being of larger diameter at the base, or between the base and the mouth, than at the mouth, and therefore holding the calking material more securely in place, and preventing its displacement from any internal pressure strain. Within the coupling collar are the locking seats *g*, which are shown formed between the inner face *d* and the calking recess on each side of the central ring *b*.

The seat may be of any suitable form, the seat preferred by me being shown in the drawings, and being formed of a rib, *h*, extending along the calking recess, back of which the body of the collar is hollowed out or depressed, as at *e*, for the reception of the lug *c* on the tubing, the lug catching behind this rib, and thus securely locking the tubing within the collar against longitudinal or drawing strain. The seat is preferably formed with a space, *l*, through which the lug in the tubing passes, and a rib, *h*, on either side of this space, so that the tubing can be turned in either direction to lock it within the collar. The inner faces of the ribs *h* may extend across the calking recesses at a slight angle, so that the lugs in the pipe may travel up the incline thus formed, and press the end of the tubing against the end of the central ring.

The number of locking lugs and seats formed on each end of the tubing and in the collar will depend on the diameter of the tubing to be connected; two such locking devices at each end being generally sufficient, except in connecting large tubing, when three or more may be employed. In figure 5 is shown another form of coupling collar in which the central ring *b* is dispensed with, and the inner face of the coupling extends between the calking recesses. Where the locking connections above described are employed the lugs fitting in the locking seats will hold the tubing in proper position in the coupling collar

*Improvements in Couplings for Tubing.*

collar, so that the ends of the tubing meet within the inner face between the calking recesses, and thus form the inner surface smooth or flush at the coupling. This form is not, however, considered as desirable as where the central ring is employed. The lugs *c* are preferably riveted on the tubing, as this does not require its reheating, though they may be welded thereto or expanded therefrom, as shown in figure 4, neither method injuriously affecting the tubing, as the lugs are supported within their seats, and the calking material enters within the seats back of the lugs, and entirely fills the calking recess above the locking connection, so that it prevents any leakage, even where there is an imperfection at the lugs. In connecting tubing by my improved coupling collar or sleeve the ends of the tube sections are inserted into the collar, the lugs *c* passing through the spaces *l*, and the ends passing up the tapering inner faces *d* being brought to proper cylindrical form, and bearing against the central ring *b*, and the tubing is then turned within the collar, either to the right or left, so as to lock the lugs behind the ribs *h*, the tubing and collar being held by this connection against longitudinal or drawing strain. Where the ribs *h* extend across the calking recesses at a slight angle the ends of the tubing are pressed against the central ring, the lugs *c* travelling up the inclined ribs, and at the same time the tapering inner faces *d* are caused to bind tightly around the ends of the tubing for the purpose above set forth. Where the tubing cannot be turned for any reason the collar can be turned on it, thus making the locking connection. The melted lead or other calking or packing material is then poured into the annular recesses *f*, and calked or solidified in the usual manner, and the coupling is made. The calking material, as it is poured into the annular recesses, enters into the spaces *l*, between the ribs *h*, and around the lugs *c*, within the locking seats *g*, and thus locks the lugs within the seats, and fills the calking recesses between the locking seats and the mouths or ends of the collar, entirely surrounding the tubing in this space above the locking connection. It thus prevents any leakage at the coupling, even though the ends of the tubing do not fit close to the central ring, or there is any imperfection at the lugs through which the water or other liquid, compressed air or gas might escape, forming an absolutely secure joint for this light metal tubing, which has been tested to a pressure of over one thousand pounds to the square inch without leaking. The locking connection within the collar also secures the coupling against the longitudinal or drawing strain consequent to the contraction and expansion of the metal in different temperatures, and as the body of the tubing is not weakened at or near the ends of the collar (the lugs being below the calking material and protected by it) there is no more liability of injury to it from lateral or bending strain at the coupling than in the body of the tubing.

I thus obtain a coupling which is comparatively inexpensive, and by which light metal tubing can be securely connected against all strains without weakening the tubing as above referred to. I also obtain a smooth inner surface to the tubing and collar when connected, so that the fluid confined has no opportunity to press through the coupling and escape, and as the inner surface of the line of tubing is smooth or flush, I do away with the friction caused by the usual joint, and for this reason require less power to force the fluid through the tubing.

As the tubing is much thinner and lighter than the ordinary threaded tubing employed for the same purpose, I effect a large saving in the cost of the tubing employed, and also in the cost of shipment, an important item with large shipments at long distances. As the collars may be secured to the tubing, when the tubing is used they may be formed at or near the place of shipment, thus saving the expense of long shipments, the couplings generally in use being necessarily formed and fitted where the tubing is manufactured.

What I claim as my invention is,—

- 1st.—In couplings for tubing, a coupling collar, having a central ring and an annular calking recess at each end, having inwardly flaring sides, substantially as and for the purposes set forth.
- 2nd.—In couplings for tubing, the combination with tubing having one or more lugs or other connecting devices at or near each end thereof of a coupling collar or sleeve provided with an inner face or faces at or near the centre thereof, corresponding locking seat or seats on each side of said inner face for the reception of the lugs on the tubing, and annular calking recesses between said locking seats and the ends of the collar, substantially as and for the purposes set forth.
- 3rd.—In couplings for tubing, the combination with tubing having one or more lugs or other connecting devices at or near each end thereof of a coupling collar or sleeve provided on the interior with a central ring, corresponding locking seat or seats on each side of the said ring for the reception of the lugs on the tubing, and annular calking recesses between such locking seats and the ends of the collar, substantially as and for the purposes set forth.
- 4th.—In couplings for tubing, a sleeve or collar having an inner central ring, tapering inner faces on each side of said ring, and annular calking recesses at each end of the collar, substantially as and for the purposes set forth.

In witness whereof, I, the said Edmund Cogswell Converse, have hereunto set my hand and seal, this twenty-fourth day of May, in the year of our Lord, one thousand eight hundred and eighty-three.

EDMUND COGGSWELL CONVERSE.

In presence of—

CHARLES CARRINGTON DORR.  
JAMES LANCASTER DE LACY.

This is the specification referred to in the annexed Letters of Registration granted to Edmund Cogswell Converse, this 28th day of August, A.D. 1883.

AUGUSTUS LOFTUS.

REPORT.

---

*Improvements in Couplings for Tubing.*

---

**REPORT.**

---

Sir,

In accordance with your B.C. minute of the 14th instant, forwarding for report the Petition of Mr. Edmund Cogswell Converse for Letters of Registration for an invention entitled "Improvements in Couplings for Tubing," we have to report that we are of opinion such letters might be issued.

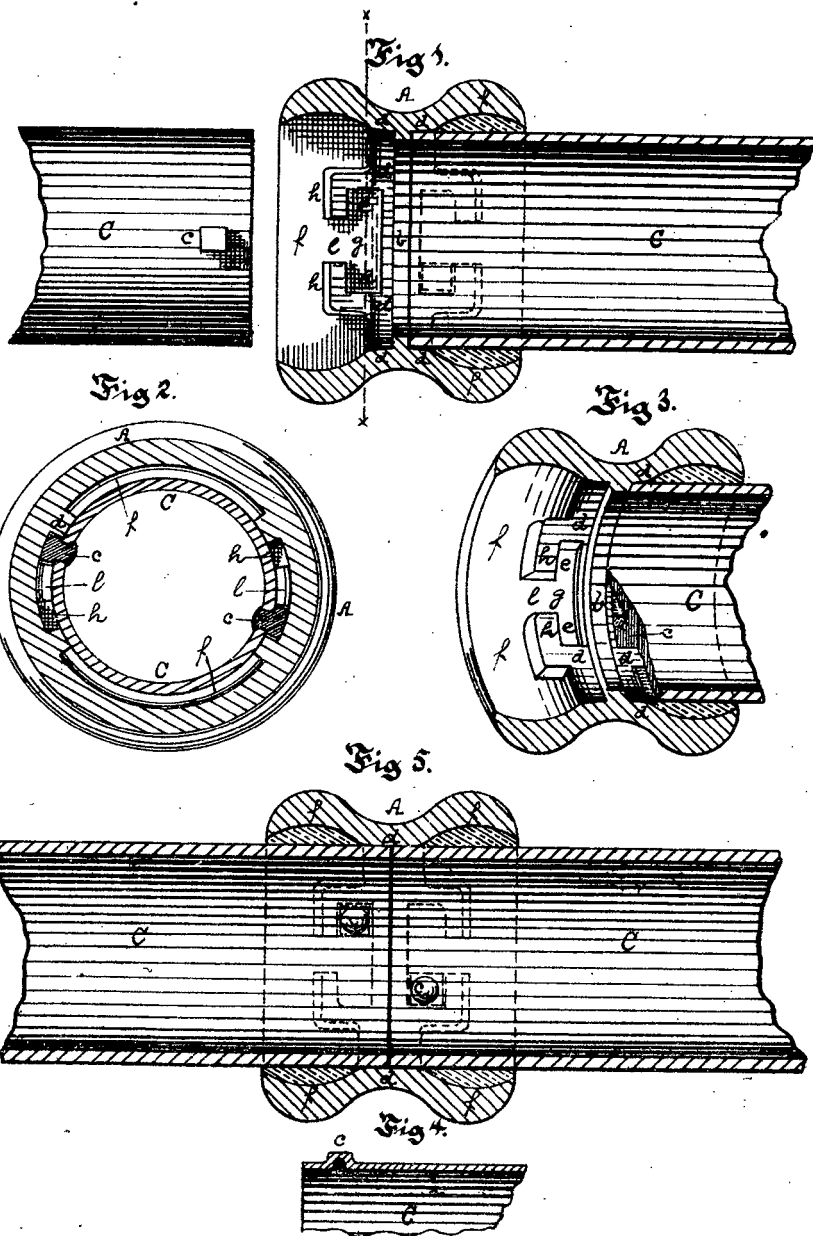
We have, &amp;c.,

Sydney, 23 July, 1883.  
JAMES BARNET.  
WILLIAM C. BENNETT.

The Under Secretary of Justice.

---

[Drawings—one sheet.]



*This is the Sheet of Drawings referred to in the annexed Letters of Registration granted to Edmund Cogswell Converse, this 28<sup>th</sup> day of August A. D. 1883.*

*Augustus Loftus.*





A.D. 1883, 28th August. No. 1305.

**MANUFACTURE OF MATERIAL IN IMITATION OF LEATHER, WOOD, FABRICS, &c.**

**LETTERS OF REGISTRATION** to The Veloplastic Company (Limited) for a new or improved manufacture of material in imitation of Leather, Wood, Fabrics, or other embossed or figured surfaces.

[Registered on the 30th day of August, 1883; in pursuance of the Act 16 Vic. No. 24.]

BY HIS EXCELLENCY THE RIGHT HONORABLE SIR AUGUSTUS WILLIAM FREDERICK SPENCER LOFTUS (commonly called LORD AUGUSTUS LOFTUS), Knight Grand Cross of the Most Honorable Order of the Bath, a Member of Her Majesty's Most Honorable Privy Council, Governor and Commander-in-Chief of the Colony of New South Wales and its Dependencies.

TO ALL TO WHOM THESE PRESENTS SHALL COME, greeting :

WHEREAS THE VELOPLASTIC COMPANY (Limited), of 4, Royal Exchange Buildings, in the City of London, England, have by their Petition humbly represented to me that they are the assignees of Henry Sowenberg, who is the author or designer of a certain invention or improvement in manufactures, that is to say, of an invention entitled "A new or improved manufacture of material in imitation of Leather, Wood, Fabrics, or other embossed or figured surfaces," which is more particularly described in the specification which is hereunto annexed; and that they, the said Petitioners, have deposited with the Honorable the Treasurer of the said Colony of New South Wales the sum of Twenty Pounds sterling, for defraying the expense of granting these Letters of Registration, as required by the Act of Council, sixteenth Victoria, number twenty-four, and have humbly prayed that I would be pleased to grant Letters of Registration, whereby the exclusive enjoyment and advantage of the said invention or improvement might be secured to them for a period of fourteen years: And I, being willing to give encouragement to all inventions and improvements in the arts or manufactures which may be for the public good, and having received a report favourable to the prayer of the said Petition from competent persons appointed by me to examine and consider the matters stated therein and to report thereon for my information, am pleased, with the advice of the Executive Council, and in exercise of the power and authority given to me by the said Act of Council, to grant, and do by these Letters of Registration grant, unto the said Veloplastic Company (Limited), their successors and assigns, the exclusive enjoyment and advantage of the said invention or improvement, for and during the term of fourteen years from the date hereof; to have, hold, and exercise unto the said Veloplastic Company (Limited), their successors and assigns, the exclusive enjoyment and advantage thereof, for and during and unto the full end and term of fourteen years from the date of these presents next and immediately ensuing, and fully to be complete and ended: Provided always, that if the said Veloplastic Company (Limited) shall not, within three days after the granting of these Letters of Registration, register the same in the proper office in the Supreme Court, at Sydney, in the said Colony of New South Wales, then these Letters of Registration, and all advantages whatsoever hereby granted, shall cease and become void.

In witness whereof, I have hereunto set my sign manual, and have caused the present Letters of Registration to be sealed with the seal of the said Colony of New South Wales, at Government House, Sydney, in New South Wales, this twenty-eighth day of August, in the year of our Lord one thousand eight hundred and eighty-three.

[L.S.]

AUGUSTUS LOFTUS.

*Manufacture of Material in Imitation of Leather, &c.*

SPECIFICATION of THE VELOPLASTIC COMPANY (Limited), of 4, Royal Exchange Buildings, in the City of London, England, the assignees of Henry Loewenberg, of Wiesbaden, in the German Empire, for an invention entitled "A new or improved manufacture of material in imitation of Leather, Wood, Fabrics, or other embossed or figured surfaces."

THIS invention relates to the manufacture of material in imitation of leather, wood, fabrics, or embossed or figured surfaces, the said material consisting of a fabric with a facing of plastic composition, which is applied in a molten semi-fluid condition, and sets when it cools, but retains a soft and pliable character.

The first operation in this process of manufacture is to produce a mould or negative, say, for instance, for the reproduction of a surface-imitating leather, with its peculiar curves and streaks, or fabrics such as brocade, with its flowers or ornamental patterns. For this purpose, a skin of the leather or a piece of the brocade is laid flat on a horizontal table, and over this is moved a sliding frame carrying a tilting trough-like vessel, which contains, in a molten condition, the composition that is to constitute the mould, as will hereafter be described. Along with the sliding frame, a knife or scraper advances, smoothing down the composition as it is poured from the trough, so that it lies in an even layer over the leather or brocade. When the composition has set, it can be stripped off, and it is then in its turn laid upon the table to serve as the mould or negative for the material that is to be produced, being previously faced with chromic acid, acetate of iron, or analogous substance, to prevent adhesion of the composition that is to be applied. This composition is applied in the same way as that for producing the negative, but on the moving frame that carries the trough there is mounted a roll of the fabric that is to form the backing, and this, unwinding itself as the frame advances, is pressed by the knife or scraper or by a roller on to the composition, to which it firmly adheres. When the composition has set, it is stripped with its backing off the mould, and the material is now in its complete state, consisting of a fabric with a facing of the composition presenting all the appearance of the leather, brocade, or other surface, from which the negative was originally formed. In cases where the mould or negative has to be repeatedly used it is advantageous to make it in the same way as the finished material, with a backing of fabric to give it strength and durability.

Such being the general character of the process of manufacture, the compositions employed are mixtures of various substances in various proportions, according to the character of the material to be produced, as will be understood from the following examples of mixtures which have been found practically useful.

For the mould or negative, a mixture of 1 or 2 parts of strong solution of a salt of copper such as the sulphate or the ammoniacret, 1 or 2 parts of a chromate or bichromate in a weak solution of about 1 part of the salt to 50 parts of water, and 1 to 1½ part of glycerine is added to 5 to 7 parts of liquid glue. This being applied to the original, preferably with a backing of fabric as above described, can be used without further preparation, as the mould or negative for receiving the composition to form the imitation material.

For the imitation material the following is a good composition:—Linseed or other drying oil is thickened to a gelatinous consistence by agitating it in a close vessel supplied with chlorine gas, or agitating it in mixture with a solution of chlorine. From 2 to 4 parts of the oil so prepared is mixed with 1 to 3 parts of caoutchouc solution, and 2 to 3 parts of colouring matter, and for certain classes of goods with 5 to 8 parts of glue or gelatine and 1 to 2 parts of glycerine. Another composition consists of 10 to 12 parts of gluc or gelatine, 2 to 4 parts of vaseline, and a small quantity not exceeding 2 parts of glycerine, 1 to 2 parts of a salt of copper, somewhat less than 1 part of a chromate or salt of iron, along with colouring matters, and, in some cases, with a very small addition of alkali.

In order to prevent penetration or action of damp, it is of advantage to apply to the fabric backing a waterproofing composition, such as a solution of caoutchouc, or a mixture of prepared oil and caoutchouc solution, as for the facing. This backing may be applied by a second operation in the same way as the facing, but it is preferable to apply both facing and backing at one operation. Thus, while the facing composition is being laid on the mould or negative, and the fabric, as it unwinds, is smoothed over it, a second trough delivers over the fabric the waterproofing composition, which is in like manner smoothed down.

In cases where caoutchouc is objectionable a solution of a chromate may be employed, this being applied to the fabric by a brush travelling along with the trough frame.

When a strong imitation material is required, two or more layers of fabric may be used with intervening layers of composition cementing them firmly together. Glycerine serves to maintain pliability of the material, but in cases where there is exposure to moisture the presence of glycerine in the composition is objectionable. It is therefore better in such cases to reduce the quantity of glycerine in the facing composition, but to soak the fabric in glycerine before it has the composition applied to it, and to apply the waterproof backing, so that the glycerine remains in the fabric enclosed between the front and back layers, and not subject to atmospheric influences.

Claim the manufacture of material in imitation of leather, wood, fabrics, or embossed or figured surfaces, by preparing a mould or negative and applying thereto a molten composition with a backing of fabric, substantially as herein described.

Claim also the composition for the moulds and for the facing and backing of the fabric, substantially as herein described.

THE VELOPLASTIC COMPANY (LIMITED),  
(By their Agent, EDW. WATERS).

This is the specification referred to in the annexed Letters of Registration granted to The Veloplastic Company, this twenty-eighth day of August, A.D. 1883.

AUGUSTUS LOFTUS.

---

*Manufacture of Material in Imitation of Leather, &c.*

---

REPORT.

Sir,

Sydney, 23 July, 1883.

In accordance with your B.C. minute of the 13th instant, forwarding for report a Petition for Letters of Registration for an invention entitled "A new or improved manufacture of material in imitation of Leather, Wood, Fabrics, or other embossed or figured surfaces," the Petitioners being The Veloplastic Company (Limited), we have to report that we are of opinion that such Letters might be issued.

We have, &c.,

JAMES BARNET.  
WILLIAM C. BENNETT.

The Under Secretary of Justice.

---

No. 1306.

[Assignment of No. 1227. See Letters of Registration for 1883, page 147.]



---

A.D. 1883, 17th September. No. 1307.

---

AN IMPROVED MACHINE FOR EXCAVATING EARTH.

---

LETTERS OF REGISTRATION to Frederick York Wolseley, for an Improved  
Machine for Excavating Earth.

[Registered on the 18th day of September, 1883, in pursuance of the Act 16 Vic. No. 24.]

---

BY HIS EXCELLENCY THE RIGHT HONORABLE SIR AUGUSTUS WILLIAM FREDERICK SPENCER LOFTUS (commonly called LORD AUGUSTUS LOFTUS), Knight Grand Cross of the Most Honorable Order of the Bath, a Member of Her Majesty's Most Honorable Privy Council, Governor and Commander-in-Chief of the Colony of New South Wales and its Dependencies.

TO ALL TO WHOM THESE PRESENTS SHALL COME, greeting :

WHEREAS FREDERICK YORK WOLSELEY, of Walgett, in the Colony of New South Wales, gentleman, hath by his Petition humbly represented to me that he is the author or designer of a certain invention or improvement in manufactures, that is to say, of an invention entitled "An Improved Machine for Excavating Earth," which is more particularly described in the specification and the sheet of drawings which are hereunto annexed; and that he, the said Petitioner, hath deposited with the Honorable the Treasurer of the said Colony of New South Wales the sum of Twenty Pounds sterling, for defraying the expense of granting these Letters of Registration, as required by the Act of Council, sixteenth Victoria, number twenty-four; and hath humbly prayed that I would be pleased to grant Letters of Registration, whereby the exclusive enjoyment and advantage of the said invention or improvement might be secured to him for a period of fourteen years: And I, being willing to give encouragement to all inventions and improvements in the arts or manufactures which may be for the public good, and having received a report favourable to the prayer of the said Petition, from competent persons appointed by me to examine and consider the matters stated therein and to report thereon for my information, am pleased, with the advice of the Executive Council, and in exercise of the power and authority given to me by the said Act of Council, to grant, and do by these Letters of Registration grant unto the said Frederick York Wolseley, his executors, administrators, and assigns, the exclusive enjoyment and advantage of the said invention or improvement, for and during the term of fourteen years from the date hereof; to have, hold, and exercise unto the said Frederick York Wolseley, his executors, administrators, and assigns, the exclusive enjoyment and advantage thereof, for and during and unto the full end and term of fourteen years from the date of these presents next and immediately ensuing, and fully to be complete and ended: Provided always, that if the said Frederick York Wolseley shall not, within three days after the granting of these Letters of Registration, register the same in the proper office in the Supreme Court, at Sydney, in the said Colony of New South Wales, then these Letters of Registration, and all advantages whatsoever hereby granted, shall cease and become void.

In witness whereof, I have hereunto set my sign manual, and have caused the present Letters of Registration to be sealed with the seal of the said Colony of New South Wales, at Government House, Sydney, in New South Wales, this 17th day of September, in the year of our Lord one thousand eight hundred and eighty-three.

[L.S.]

AUGUSTUS LOFTUS.

*An Improved Machine for Excavating Earth.*

SPECIFICATION of FREDERICK YORK WOLSELEY, of Walgett, in the Colony of New South Wales, gentleman, for an invention entitled "An Improved Machine for Excavating Earth."

THIS invention of an improved machine for excavating earth consists of two main parts, the one being for the purpose of loosening or ploughing up the earth, and the other being for the purpose of scooping and lifting the loosened or ploughed earth, and delivering it into dobbins or other suitable receptacles.

The loosening or ploughing contrivances consist of long teeth, supported on a frame after the fashion of scarifier or cultivator teeth, such frame being adjustable upwards and downwards simultaneously with the scooping and lifting contrivances. These latter contrivances consist of a wheel, on the broad periphery of which is a series of scooping buckets with bottoms partly movable, so arranged as to move forward and give an impetus to the contained earth at the point of or as it approaches the point of discharge. This scooping and lifting wheel is supported on an axle, which moves freely in a segmental slot attached to the framing of the machine, so that within the limits of such segmental slot the wheel is free to rise and fall. This freedom is only checked by chains, which lift and lower it simultaneously with the loosening or ploughing contrivances. It is lifted when the machine is required to be moved from place to place, and lowered to the required depth when at work.

In order, however, that my invention may be clearly understood, I will now proceed to refer to my drawings hereto attached and forming part of this specification. Figure 1 shows side elevation of my machine; figure 2, plan of same, omitting plan of shoot N and stays A<sup>3</sup> for the sake of clearness; figure 3, front elevation of same, here also omitting side view of stays A<sup>3</sup> and A<sup>5</sup>, also hand-wheel K<sup>1</sup>, for the sake of clearness. Figure 4 shows plan of part of one of the scooping buckets, and figure 5 front elevation of a modification of the loosening or ploughing contrivances, in which provision is made for operating on the sides of a trench as well as on the bottom of it.

A is the main framing of the machine, made of angle-iron, from which proceeds an arch A<sup>1</sup> of T-iron. A<sup>2</sup>, A<sup>3</sup>, and A<sup>4</sup> are stays to the arch. A<sup>5</sup> are horizontal stays from the bearings B of the draught-wheels B<sup>1</sup> to the main framing A. Said bearings are bolted to the under-side of framing A. C is the under-carriage of front wheels C<sup>1</sup>, and is connected to the main framing by king-bolt D. On this king-bolt works the front end of framing E of the teeth E<sup>1</sup>, which loosen or plough up the earth. The hinder end of this framing hinges on pivots, which are carried in bearings E<sup>2</sup> cast on the under-side of the plate, on which is also cast the bearings B of the draught-wheels B<sup>1</sup>; and it will be noticed that the king-bolt D is necessarily curved in line with a circle struck from the pivots at E<sup>2</sup>, so as to allow the under-carriage C to work on it when being lowered into or raised out of the ground, in order to do which said under-carriage is supported on each side by a chain C<sup>2</sup>, the other ends of which are fastened to the periphery of chain-sheaves C<sup>3</sup> on axle F. The teeth E<sup>1</sup> are fastened to their framing in the ordinary way by screw-clamps and nuts E<sup>3</sup>. G G are the two circular cheeks of the scooping and lifting wheel, and between such cheeks are formed the scooping buckets G<sup>1</sup>, the hinder part of the bottoms of which G<sup>2</sup> are movable, and work on rods F<sup>2</sup>, which pass through the arms G<sup>3</sup> attached to both ends of this portion of the bucket G<sup>2</sup>. These rods F<sup>2</sup> pass through the sides of cheeks and of rings G<sup>4</sup> fixed to them, which rings also serve as a seating for the movable bottom when filled with earth. The back ends of the buckets are fixed to the cheeks, and form an arc of a circle struck from the centre of rod F<sup>1</sup>, as shown, and the movable part of the bottom is just made short enough to clear it when working. It will be noticed that the movable part of the bottom naturally assumes the position shown at P before entering the ground, but is pushed back again into line with the fixed part of the bottom by the earth scooped into it, and is forced forward when approaching the point of discharge, by reason of arms G<sup>3</sup> fixed to said movable portion being forced backwards on coming into collision with friction-rollers H. These rollers revolve on studs or pins H<sup>1</sup>, which are adjustable by nuts H<sup>2</sup> up and down the slotted brackets H<sup>3</sup>, said brackets being supported at points 1 and 2 by stays A<sup>2</sup>, and at point 3 by being bolted to the main framing A. The axle G<sup>4</sup> of the scooping and lifting wheel works in bearings which slide in the arc slots G<sup>5</sup>, which are supported at three points—first, by attachment to the main framing at G<sup>6</sup>; second, by attachment at G<sup>7</sup> to stay J (also attached to main framing); and third, by attachment to arch A<sup>1</sup> at G<sup>8</sup>. On the axle of the draught-wheels B<sup>1</sup> is a spur pinion B<sup>2</sup> driving toothed wheel G<sup>9</sup> on axle G<sup>4</sup> of scooping and lifting wheel. Near each end of said axle is a loose collar G<sup>10</sup> having an eye, to which is attached a chain G<sup>11</sup> passing over loose chain-sheave G<sup>12</sup>, and winding on chain-sheave G<sup>13</sup> on axle F. K is a worm-gear worked by hand-wheel K<sup>1</sup>, and driving tangent wheel K<sup>2</sup> on said axle F. On the off side of the machine is a hand-lever L attached by rod L<sup>1</sup> to short lever L<sup>2</sup> on end of rocking shaft L<sup>3</sup>, on which is hook L<sup>4</sup>. M is a bracket or standard, in which is a slot M<sup>1</sup>; and N is a shoot, on each side of which is also a slot N<sup>1</sup>. Screw-studs P passing through both these slots fasten the shoot in any required position.

The mode of operation is as follows:—When the machine is at work the hand-wheel K<sup>1</sup> is revolved until the teeth E<sup>1</sup> of the loosening and ploughing contrivances, as well as the scooping and elevating contrivances, are at proper level for the depth of cut required. In figure 1 they are shown at almost their lowest level. A dobbin or other receptacle is hooked on to the hook L<sup>4</sup> and the machine moved forward; the result is that the teeth E<sup>1</sup> loosen and plough up the soil, the scooping and lifting wheel revolves, and the scooping buckets G<sup>1</sup> scoop up the soil, carrying it round to the point of discharge at the back; as they approach which the arms G<sup>3</sup> strike against the friction rollers H, and the hinder part of the bottom G<sup>2</sup> is thus forced forward, giving an impetus to the contents of the bucket towards the shoot N, down which it passes into the dobbin or other receptacle. When this is full the machine is stopped, the hand-lever L pushed backward, thus rocking the shaft L<sup>3</sup> and lowering the point of the hook L<sup>4</sup>; the full dobbin is then removed, and an empty one supplied in its place. The hand-lever L is then pushed forward again, thus fixing the empty dobbin to the machine, and the work of excavation resumed by drawing the machine forward. When the machine has finished work the hand-wheel K<sup>1</sup> is revolved, so as to lift the ploughing and scooping contrivances some little distance above the earth, the axle G<sup>4</sup> of the scooping and lifting wheel reaching the top of its slotted bearings, so as to throw the toothed wheel G<sup>9</sup> out of gear with its spur pinion B<sup>2</sup>.

If

*An Improved Machine for Excavating Earth.*

If so desired, there may be added to the loosening or ploughing contrivances other teeth E, working obliquely from their framing, as shown in figure 5, for the purpose of cutting drains or otherwise.

Having thus described the nature of my invention and the manner of performing same, I would have it understood that I do not claim broadly to be the inventor of teeth for loosening or ploughing earth, nor yet of wheels which scoop and lift loosened or ploughed earth; but what I do claim as the novelties of my improved machine for excavating earth, and for which I am desirous of securing Letters of Registration, is—

First—The combination of the main framing A and the arched framing A<sup>1</sup> in machines of this description.

Second—Hinging the frame of the ploughing teeth E at a point near the centre of the main framing A, and supporting the other end by chains C<sup>2</sup> from a grooved pulley C<sup>3</sup> fixed on a shaft, to which motion is given as required.

Third—The curved king-bolt D in connection and combination with such an arrangement as is described in the preceding claim.

Fourth—Scooping and lifting wheels substantially as described, and especially with the hinder part of the bottom of the scoops hinged, and with arms thereon acted upon by friction rollers or other equivalent contrivance in the manner and for the purpose described.

Fifth—Providing such scooping and lifting wheels with segmental slotted bearings, and with the special contrivances shown for lifting and lowering such wheels.

Sixth—The special arrangement of parts, by which the ploughing contrivances and the scooping and lifting contrivances are raised and lowered simultaneously by one motion.

In witness whereof, I, the said Frederick York Wolseley, have hereunto set my hand and seal, this eighteenth day of July, one thousand eight hundred and eighty-three.

F. Y. WOLSELEY,

(By his duly authorized Attorney, EDWARD WATERS).

Witness—

W. S. BAXSTON,

Patent Law Clerk, Melbourne.

This is the specification referred to, in the annexed Letters of Registration granted to Frederick York Wolseley, this seventeenth day of September, A.D. 1883.

AUGUSTUS LOFTUS.

### REPORT.

Sir,

We do ourselves the honor to report, in reply to your B.C. of the 21st ultimo, transmitting Mr. Frederick York Wolseley's Petition for the registration of "An Improved Machine for Excavating Earth," that we are of opinion the prayer of the Petitioner may be granted, in terms of his specification and drawings.

We have, &c.,

E. C. CRACKNELL.

GOTHER K. MANN.

The Under Secretary of Justice.

[Drawings—one sheet.]

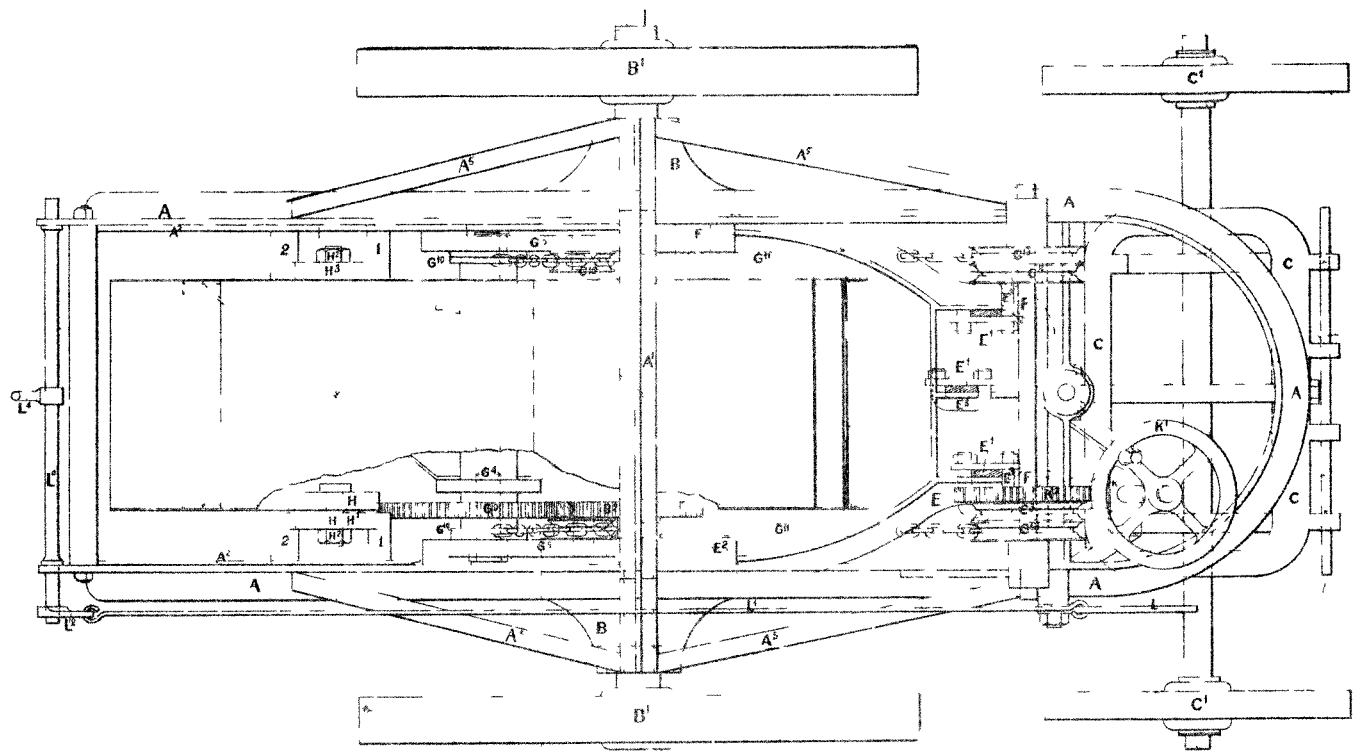


FIG 2

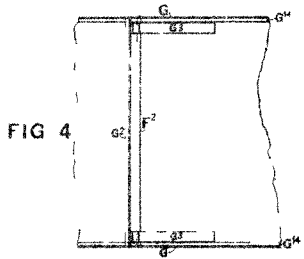


FIG 4

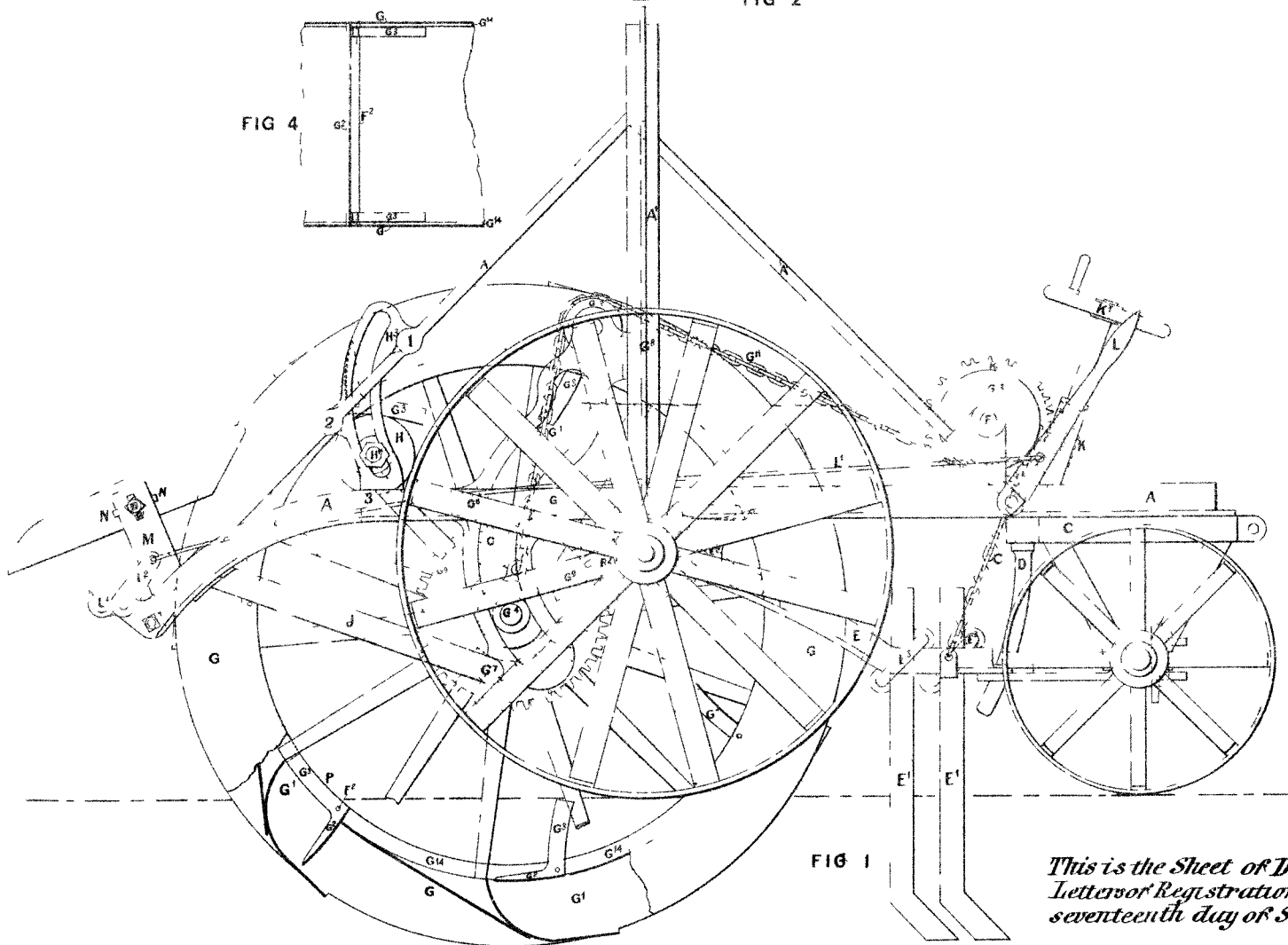


FIG 1

F. Y. WOLSELEY'S PATENT

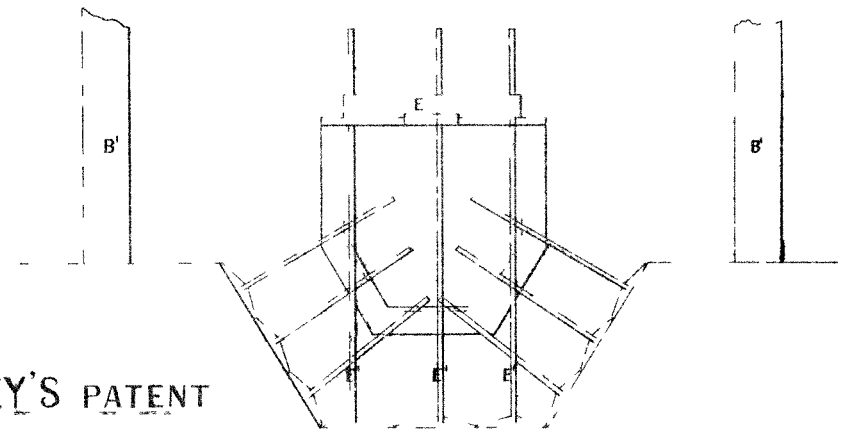


FIG 5

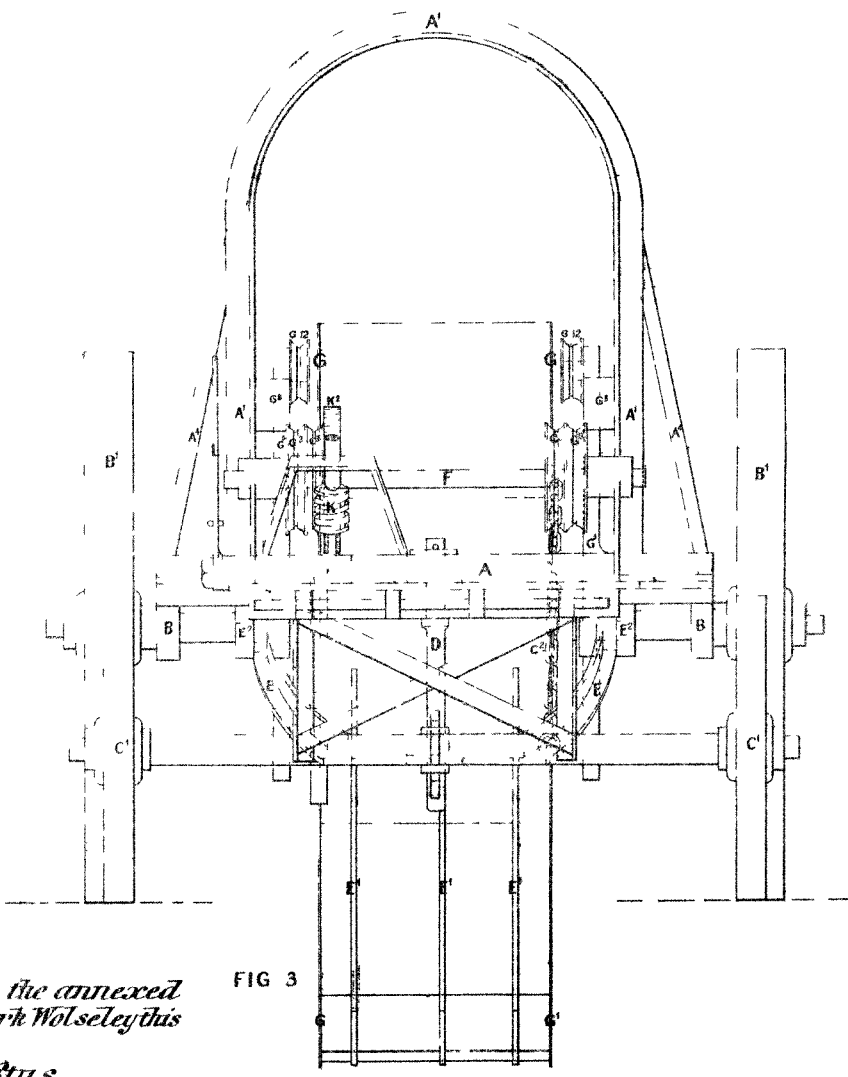


FIG 3

*This is the Sheet of Drawings referred to in the annexed  
 Letter or Registration granted to Frederick York Wolseley this  
 seventeenth day of September, A.D 1883.  
 Augustus Loftus.*



A.D. 1883, 17th September. No. 1308.

IMPROVEMENTS ON AND RELATING TO AUTOMATIC CAR BRAKES.

LETTERS OF REGISTRATION to Stephen Preston Tallman, for Improvements on and relating to Automatic Car Brakes.

[Registered on the 18th day of September, 1883, in pursuance of the Act 16 Vic. No. 24.]

BY HIS EXCELLENCY THE RIGHT HONORABLE SIR AUGUSTUS WILLIAM FREDERICK SPENCER LOFTUS (commonly called LORD AUGUSTUS LOFTUS), Knight Grand Cross of the Most Honorable Order of the Bath, a Member of Her Majesty's Most Honorable Privy Council, Governor and Commander-in-Chief of the Colony of New South Wales and its Dependencies.

TO ALL TO WHOM THESE PRESENTS SHALL COME, greeting :

WHEREAS STEPHEN PRESTON TALLMAN, of the town of Dunellen, in the county of Middlesex, and State of New Jersey, gentleman, hath by his Petition humbly represented to me that he is the author or designer of a certain invention or improvement in manufactures, that is to say, of an invention entitled "Improvements on and relating to Automatic Car Brakes," which is more particularly described in the specification and the sheet of drawings which are hereunto annexed; and that he, the said Petitioner, hath deposited with the Honorable the Treasurer of the said Colony of New South Wales the sum of Twenty Pounds sterling, for defraying the expenses of granting these Letters of Registration, as required by the Act of Council, sixteenth Victoria, number twenty-four; and hath humbly prayed that I would be pleased to grant Letters of Registration, whereby the exclusive enjoyment and advantage of the said invention or improvement might be secured to him for a period of fourteen years; And I, being willing to give encouragement to all inventions and improvements in the arts or manufactures which may be for the public good, and having received a report favourable to the prayer of the said Petition, from competent persons appointed by me to examine and consider the matters stated therein and to report thereon for my information, am pleased, with the advice of the Executive Council, and in exercise of the power and authority given to me by the said Act of Council, to grant, and do by these Letters of Registration grant unto the said Stephen Preston Tallman, his executors, administrators, and assigns, the exclusive enjoyment and advantage of the said invention or improvement, for and during the term of fourteen years from the date hereof; to have, hold, and exercise unto the said Stephen Preston Tallman, his executors, administrators, and assigns, the exclusive enjoyment and advantage thereof, for and during and unto the full end and term of fourteen years from the date of these presents next and immediately ensuing, and fully to be complete and ended: Provided always, that if the said Stephen Preston Tallman shall not, within three days after the granting of these Letters of Registration, register the same in the proper office in the Supreme Court, at Sydney, in the said Colony of New South Wales, then these Letters of Registration, and all advantages whatsoever hereby granted, shall cease and become void.

In witness whereof, I have hereunto set my sign manual, and have caused the present Letters of Registration to be sealed with the seal of the said Colony of New South Wales, at Government House, Sydney, in New South Wales, this seventeenth day of September, in the year of our Lord one thousand eight hundred and eighty-three.

[L.S.]

AUGUSTUS LOFTUS.



*Improvements on and relating to Automatic Car Brakes.*

## SPECIFICATION.

TO ALL WHOM IT MAY CONCERN: Be it known that I, STEPHEN PRESTON TALLMAN, a citizen of the United States, residing at Dunellen, in the county of Middlesex, and State of New Jersey, one of the United States of America, gentleman, have invented certain new and useful improvements on and relating to Automatic Car Brakes, of which the following is a full, clear, and exact specification.

THIS invention relates to that class of brakes for railway-cars in which the checking of the engine, and the consequent closing of the cars upon each other by their momentum, serves to set the brakes upon the wheels.

In the drawings which serve to illustrate my invention, figure 1 is a bottom view or plan of one-half of a car bottom, showing one truck and the evener between the trucks. Figure 2 is a front elevation of the same. Figure 3 is a vertical longitudinal section. Figure 4 represents two enlarged views of the ratcheted gear-wheel.

Let A represent generally the base frame of the car body, and B the truck frame under one end of the same, in which are journaled the axles CC, bearing the truck wheels DD. EE are the ordinary brake-bars, and *aa* the shoes. All of these may be arranged in the usual way. F is a friction-pulley, fixed on one of the car axles of the truck, and G is a friction-pulley mounted on an axle or shaft *b*, one end of which has a bearing in a pendent lever *c*, and the other a bearing at *d* on the truck frame, so constructed that the shaft may have a little lateral play. On the shaft *b* is fixed a wheel or pinion *e*, arranged to mesh with a toothed wheel, *f*, mounted loosely on a windlass shaft or barrel, *g*, which is mounted in bearings in the truck frame. The peculiar construction of this wheel *f* will be more fully hereinafter explained.

A pivoted lever, *h*, is hung to the end brake-bar, and from one end of this lever a rod *i* extends to and takes hold of the other brake-bar, and from the opposite end of the lever, another rod, *j*, extends to and takes hold of an evener, H, pivoted or hung to the under side of the car. From the other end of this evener a bar and chain, *k*, extends back to the windlass *g*, upon which it is wound when the brakes are set.

In this construction each truck of the car is provided with a brake mechanism like that shown in the figures; but it is deemed unnecessary to show more than one.

A rod, *j'*, extends from the evener to the pivoted lever *h*, at the opposite end of the car, and a rod and chain, *k'*, extends from the opposite end of the evener to the windlass at the opposite end of the car. By the employment of this evener the automatic setting of the brakes at either end of the car sets all of the brakes.

I is a push-bar, the rear end of which passes through an eye in the upper end of the lever *c*, and is provided with a cushion-spring, *m*, and an adjustable set collar as shown in figure 3. This bar is mounted directly under the draw-bar J, and is provided with a retracting spring, *m*, and an adjustable head, *n*, which takes behind a lug, *o*, on the said draw-bar when the push-bar is in its operative position. In order that the bar I may be swung out to one side, laterally, so that its head, *n*, will not stand behind the lug *o*, I mount a lever, *l*, in the frame A, and connect its lower end to the push-bar I, by means of a coupling bar or link *r*. The bar I slides freely through this link, and the spring *m* is retained between the said link and the head *n*. The bar I is supported in its horizontal position by means of a stirrup, *r'*, secured to the car-body.

When the brake is in operative condition, the head *n* takes behind a projecting lug, *o*, or some projecting part of the draw-bar J. The push-bar being hung loosely at its inner end, its head *n* may be readily thrown out from behind the lug *o* by means of the lever *l*.

Having described thus far the construction of my brake, I will now describe its operation.

When the cars come together in checking up, the draw-bar J is driven in. This drives in the push-bar I, which pushes back the upper extremity of the lever *c*, and thus brings the pulleys F and G into frictional contact. The rotation thus imparted to the friction-pulley G acts through the gears *e* and *f* to rotate the windlass *g*, and wind up the brake-chain *k*, which sets all of the brakes on the car.

Referring to figure 4, the gear wheel *f* is shown as provided with two gravity pawls, *q*, arranged in a casing, *s*. These pawls engage a ratchet-wheel, *u*, fixed on the windlass-barrel *g*. Thus it will be seen that when the wheel *f* is rotated in one direction the pawls drive the barrel *g* around with them; but when it is rotated in the opposite direction the pawls play over the ratchet-teeth, and the barrel is not rotated.

As before stated, the brake mechanisms at the opposite ends of the car are constructed precisely alike, but reversed in arrangement—that is, the free ends of the pawls *q* in the two sets point in opposite directions—the one at the front end of the car pointing to the front, and the one at the rear end pointing to the rear; and the ratchets *u* are arranged to correspond with this arrangement of the pawls. Therefore, as I only employ one set of brake mechanism at a time, that at the forward end of the car for the time being, the other set being rendered temporarily inoperative, I am enabled to back the cars without setting the brakes, as the pawls *q*, when the car is moving backward, will ride over the teeth of the ratchet *u*, and not operate the windlass.

It is important in an automatic brake of this class that it be actuated only from the forward end of the car, whichever end be for the time foremost, and that the brake mechanism at the other end be rendered temporarily inoperative. The reason for this is, that when the cars come together in stopping, the brakes are set and remain so. Consequently, when the engine starts, it should relieve the brakes of the first car, and it, in starting, should relieve the brakes of the second, and so on to the end of the train. When the brakes are set and relieved only from the foremost end of the car, this will be the case; but if the brakes are set from both ends of the car, or from the rear ends only, each car must be started with the brakes on. I therefore, in making up the train, render the brakes inoperative from the rear end of each car by throwing over the lever *l*, so as to set the head of the push-bar I clear of the lug *o* on the draw-bar. The draw-bar may then be driven in by the collision of the cars without actuating the push-bar. To maintain this position of the lever *l*, I provide a key or wedge, *p*, which may be inserted into the lever-socket on either side of the lever, and thus prevent it from shifting. This key I consider an efficient device for the purpose; but other devices of a similar character may be employed.

To

*Improvements on and relating to Automatic Car Brakes.*

To enable me to adjust the head *n* on the push-bar *I*, I provide it with an internal thread, and, preferably, a lock-nut, as shown; but it may be made adjustable by other well-known means. I also bevel the head *n*, so as to ensure its passing behind the lug in shifting. Other equivalent means may readily be devised for shifting the head of the push-bar; and I do not confine myself to the precise construction shown.

In some cases the brakes are omitted from one of the trucks of the car. Where this is the case, I arrange my operative mechanisms precisely as shown, omitting only such rods as would be employed to connect the omitted brakes to the operative mechanism and the evener; or, if sets of brakes be employed on both trucks and the evener be omitted, each set of brakes will be operated independently by its operative mechanism; and in such an arrangement, when the mechanism at one end is rendered inoperative, the brakes at that end will not be set from the mechanism at the other end. This arrangement is not, however, desirable.

The evener *H* is in common use with well-known brake mechanisms for connecting the mechanisms at opposite ends of the car; and I make no claim to it.

The ratchet device may be placed in the pulley *G*, or pinion *e*, instead of the gear-wheel *f*, if desired; but, for convenience, I prefer to arrange it in the wheel *f*. If the circumstances of the case require it, I may also employ an intermediate between the wheels *e* and *f*.

The distinguishing features of novelty in my present invention consist partly in the arrangement of a ratchet, not necessarily reversible, in the gear *f* in connection with the shifting mechanism, whereby the mechanism at one end is rendered inoperative, thus enabling me to back the cars or run them with either end foremost without reversing the pawls, one pawl being arranged once for all inversely to the other.

It also consists in the construction and arrangement of the push-bar in such a manner that it may be readily shifted, and in certain minor combinations and arrangements of parts, as will be more specifically set forth in the claims.

I claim—

1. In an automatic car-braking mechanism, the gear-wheel, provided with a pawl in combination with the windlass-barrel, provided with the ratchet-wheel fixed thereon, the pinion, shaft *b*, fixed friction-wheels *F G*, lever *c*, push-bar *I*, the draw-bar *J*, provided with a lug *o*, and the brake-bars, shoes, and rods, all constructed and arranged to operate substantially as set forth.
2. In an automatic car-braking mechanism, the push-bar *I*, provided with the retracting-spring *m*, and arranged to be shifted substantially as shown, in combination with the draw-bar *J*, provided with a lug or projection arranged in front of the push-bar, all substantially as and for the purposes set forth.
3. The combination of the head *n* of the push-bar *I* and the lug *o* on the draw-bar *J*, as specified.
4. The combination of the push-bar *I*, the lever *l* connected therewith, and arranged to shift the said bar, a suitable key or stop *p*, and the draw-head *J*, provided with a projection *o*, the push-bar being provided with a retracting spring, and all arranged to operate substantially as set forth.
5. The combination in a car-braking mechanism of the draw-bar provided with the lug *o*, the push-bar provided with cushion and retracting springs, the lever *l* arranged to shift the push-bar, the lever *c*, shaft *b*, pulleys *FG*, pinion *e*, toothed-gear *f* provided with a pawl or pawls, the windlass-barrel *g* provided with the fixed ratchet *u*, and the brake-bars, shoes, and chains or rods, all arranged to operate substantially as set forth.

In witness whereof I have hereunto signed my name in the presence of subscribing witnesses.

Witnesses—

W. A. STEEL.  
D. M. KITCHELL.

STEPHEN PRESTON TALLMAN.

And also in witness whereof the said Stephen Preston Tallman has hereto set his hand and seal, this thirteenth day of June, 1883.

Witness—

FRED. WALSH,  
Mgr., Edward Waters' Patent Office, Sydney.

STEPHEN PRESTON TALLMAN,

(By his Attorney, WM. ED. WILSON).

This is the specification referred to in the annexed Letters of Registration granted to Stephen Preston Tallman, this seventeenth day of September, A.D. 1883.

AUGUSTUS LOFTUS.

## REPORT.

Sir,

In reference to your B.C. communication of the 15th ultimo, forwarding a Petition from Mr. Stephen Preston Tallman for Letters of Registration for an invention entitled "Improvements on and relating to Automatic Car Brakes," we have the honor to inform you that, having examined the specification and plans accompanying the Petition, we recommend that Letters of Registration should be issued to the Petitioner for the invention referred to.

We have, &c.,

JOHN WHITTON.  
E. O. MORIARTY.

The Under Secretary of Justice.

Fig. 1.

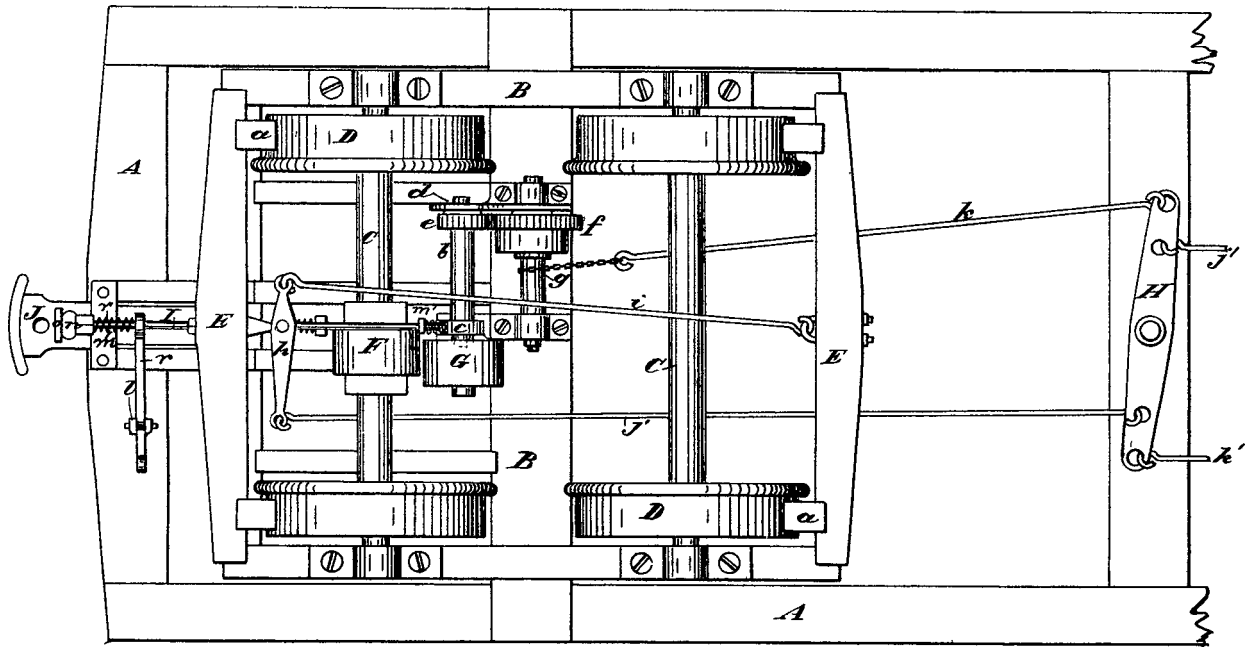


Fig. 2.

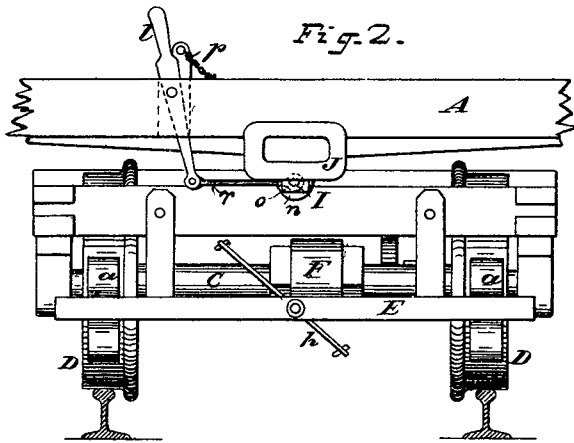


Fig. 3.

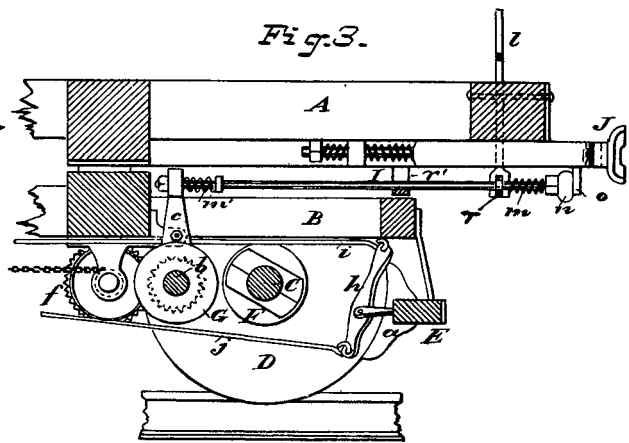
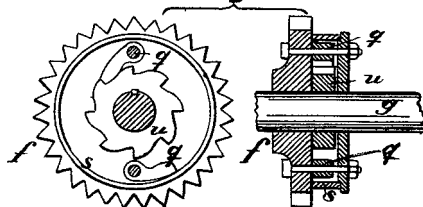


Fig. 4.



*This is the Sheet of Drawings referred to in the annexed Letters of Registration granted to Stephen Preston Tallman, this 17<sup>th</sup> day of September A.D. 1883.*

*Augustus Loftis.*



A.D. 1883, 17th September. No. 1309.

**IMPROVEMENTS IN THE TREATMENT OF IRON OR STEEL INGOTS.**

**LETTERS OF REGISTRATION** to Arthur Cooper, for Improvements in the treatment of Iron or Steel Ingots.

[Registered on the 18th day of September, 1883, in pursuance of the Act 16 Vic. No. 24.]

BY HIS EXCELLENCY THE RIGHT HONORABLE SIR AUGUSTUS WILLIAM FREDERICK SPENCER LOFTUS, (commonly called LORD AUGUSTUS LOFTUS), Knight Grand Cross of the Most Honorable Order of the Bath, a Member of Her Majesty's Most Honorable Privy Council, Governor and Commander-in-Chief of the Colony of New South Wales and its Dependencies.

TO ALL TO WHOM THESE PRESENTS SHALL COME, greeting :

WHEREAS ARTHUR COOPER, of "The Laurels," Linthorpe, Middlesbro', in the county of York, England, hath by his Petition humbly represented to me that he is the author or designer of a certain invention or improvement in manufactures, that is to say, of an invention entitled "Improvements in the treatment of Iron or Steel Ingots," which is more particularly described in the specification which is hereunto annexed, marked "A," and the sheets of drawings marked "B" and "C" respectively, and also hereunto annexed; and that he, the said Petitioner, hath deposited with the Honorable the Treasurer of the said Colony of New South Wales the sum of Twenty Pounds sterling, for defraying the expense of granting these Letters of Registration, as required by the Act of Council, sixteenth Victoria, number twenty-four, and hath humbly prayed that I would be pleased to grant Letters of Registration, whereby the exclusive enjoyment and advantage of the said invention or improvement might be secured to him for a period of fourteen years: And I, being willing to give encouragement to all inventions and improvements in the arts or manufactures which may be for the public good, and having received a report favourable to the prayer of the said Petition, from competent persons appointed by me to examine and consider the matters stated therein and to report thereon for my information, am pleased, with the advice of the Executive Council, and in exercise of the power and authority given to me by the said Act of Council, to grant, and do by these Letters of Registration grant unto the said Arthur Cooper, his executors, administrators, and assigns, the exclusive enjoyment and advantage of the said invention or improvement for and during the term of fourteen years from the date hereof; to have, hold, and exercise unto the said Arthur Cooper, his executors, administrators, and assigns, the exclusive enjoyment and advantage thereof, for and during and unto the full end and term of fourteen years from the date of these presents next and immediately ensuing, and fully to be complete and ended: Provided always, that if the said Arthur Cooper shall not, within three days after the granting of these Letters of Registration, register the same in the proper office in the Supreme Court, at Sydney, in the said Colony of New South Wales, then these Letters of Registration, and all advantages whatsoever hereby granted, shall cease and become void.

In witness whereof, I have hereunto set my sign manual, and have caused the present Letters of Registration to be sealed with the seal of the said Colony of New South Wales, at Government House, Sydney, in New South Wales, this seventeenth day of September, in the year of our Lord one thousand eight hundred and eighty-three.

[L.S.]

AUGUSTUS LOFTUS.

*Improvements in the treatment of Iron or Steel Ingots.*

## A.

SPECIFICATION of ARTHUR COOPER, of "The Laurels, Linthorpe, Middlesbro', in the county of York, England, for an invention entitled "Improvements in the treatment of Iron or Steel Ingots."

THIS invention relates to the treatment of hot steel or iron ingots immediately after casting, and before they are hammered and rolled. At present the ingots, after removal from the moulds, are usually heated in heating furnaces. My invention consists in the treatment of the ingots in and by the improved arrangement and apparatus hereinafter described, which enables the equalization of the heat which they possess to be effected, and the ingots to be rolled without subsequent reheating. In carrying out my invention, I construct one or more tunnels, which may be either above or below the ground level. In the accompanying drawings, which form part of this specification,—

Figure 1 represents in side elevation an advantageous arrangement when the tunnel is made below the ground or surface level.

Figure 2 represents a plan of same.

Figure 3 represents a sectional elevation of the tunnel at the part at which the ingots are removed.

Figure 4 represents an overground tunnel for a single row of ingots.

Figure 5 represents a plan of same.

Figure 6 represents a sectional elevation of figure 5; and

Figure 7 represents a tunnel in which the ingots are laid upon their sides therein.

To prevent the radiation of heat, the walls and roof should be very thick. The lining is preferably of the best fire-brick. The tunnel or tunnels run from the casting pit to the immediate neighbourhood of the cogging or blooming mill or hammer. They may be either straight or return by a curve to the casting pit. If a straight tunnel is used, which is always preferable, particularly when the distance between the casting pit and the mill is a short one, a second or return tunnel is desirable; or if a large make of ingots has to be dealt with, even three or more such tunnels may be constructed side by side, and these may be used alternately. The tunnels have easily removable and closely-fitting fire-brick doors or dampers *b*, dividing them into several sections as shown. It is preferred that each section should be just large enough to take one cast. The doors or dampers may be opened either by raising them vertically as ordinary furnace doors, or they may be arranged to move horizontally, and they may be made in either one or more parts. There are several modes in which the ingots can be moved along from the casting pit to the mill,—this transference in my system being always accomplished inside the tunnel without exposure to the air. The method I prefer is that of running the ingots through the tunnel to the mill on very low bogies of either wrought or cast iron, running on wheels on a tramway, as shown at *c*, figures 1, 3, 4, 6, and 7, the wheels being protected from the heat of the ingots and the upper part of the tunnel by the bogie platforms, which are sheeted with fire-brick, and so arranged, that they form a joint more or less airtight, with the sides of the tunnel. For this purpose, I prefer that the sides of the bogie platforms project into channels or grooves formed in the tunnel sides (see figure 3); or the bogie top and sides may be in the form of an inverted box sheeted with fire-brick on the outside, the wheels running underneath, as in figures 4 and 6, *c*. The bogies—which I prefer should be of such a length, that one or more will just fill a section of the tunnel between two of the fire-brick dampers, so that the platforms will form a continuous surface, protecting the carriage, body, and wheels, from the heat—are moved along the tunnel by a chain or rope of iron or steel, and a winch, or by an endless chain. The ingots may be placed on the bogies either vertically, as in figures 1, 3, 4, and 6, or horizontally and lengthwise, as in figure 7; or they may be placed crosswise on the bogies, the tunnels in each case being built so as to give a clearance in cross section of about 3 inches round the ingot. I find that the system of casting which, when used in conjunction with my tunnel-equalizing chambers, gives the best results, is that in which the ingots are cast on trolleys or bogies which, after removal of the mould, can be run with the hot ingots directly into the hot tunnel. When the casting is conducted in longitudinal pits below the ground, the hot tunnels may be made as continuations of the pits, of which a complete arrangement is shown in figures 1 and 2, where *c* represents the converters; *f*, the centre crane for transferring the ladle *g* to carriage *h*, from which the ingots are cast in longitudinal pits *i, i*; after the ingot moulds *j* are removed by cranes *k k*, the damper *b* is raised, and the bogie of hot ingots is passed direct into the hot tunnels *a a*; and if the tunnel consists of two sections as shown, or more than two sections, it is immediately passed forward to that one adjacent to the cogging rolls, and as soon as the heat in the ingots has become sufficiently equalized for rolling, the closely-fitting stoppers or covers *l, l* are removed from the apertures which I make in the roof of that part of the tunnel, and the ingots are lifted out by crane and transferred to cogging-mill rollers. When the tunnels are constructed above the ground, as shown in figures 4, 5, and 6, the ends near the cogging mill, as well as the ends near the casting pit, are closed with easily removable and closely-fitting doors or dampers *b, b*. As soon as the ingots forming a cast, or a part of a cast, have been passed into the tunnel at the casting shop end *o*, the damper or door *b* is closed, and when the heat has become sufficiently equalized for rolling, the door *b*, at the cogging-mill end *P*, is raised, and the bogie or bogies of ingots are moved forward until the first ingot stands just outside the tunnel, in such a position that the door may be shut down on the top of the bogie between the first and second ingots, thus preserving the heat in the tunnel whilst the first ingot is being rolled.

As soon as this is done, the door is again raised, and the bogies moved forward, until the second ingot appears outside the tunnel, when the door is shut down between the second and third ingots; whilst the second is being rolled, the other ingots remaining are dealt with in a similar manner. The ingots can be lifted from the bogies to the rolls or hammer by an ordinary ingot crane, as shown in figures 1 and 2. This arrangement of doors or dampers and mode of working the ingots from the tunnels above ground, is equally efficient when applied to underground tunnels; but it will be apparent, that in this latter case, it will be necessary to make a longitudinal pit as a continuation of the tunnels at the cogging-mill end, of sufficient length to hold the bogie or bogies, after the last ingot forming the cast has passed out of the end of the tunnel.

Having

*Improvements in the treatment of Iron or Steel Ingots.*

Having thus described the nature of my invention, and how the same may be practically employed, what I claim and desire to secure by Letters Patent is,—

First—The hereinbefore described process for treating hot ingots so as to equalize their heat, which consists in casting or otherwise placing said ingots upon trucks or bogies, and then passing both the ingots and the trucks through tunnels formed of refractory material, substantially in the manner and for the purposes set forth.

Second—In the treating of hot ingots, the combination with a tunnel of refractory material of movable doors or slides dividing said tunnel into two or more chambers or sections, substantially as and for the purposes set forth.

Third—In the treating of hot ingots, the combination with the tunnel of refractory material of one or more trucks or bogies adapted to make a loose fit with the sides, and to form a more or less continuous platform between the hot ingots and the floor of the tunnel, all substantially as and for the purposes set forth.

In witness whereof, I, the said Arthur Cooper, have hereunto set my hand and seal, this twenty-fourth day of May, in the year of our Lord one thousand eight hundred and eighty-three.

ARTHUR COOPER.

This is the specification marked "A," referred to in the annexed Letters of Registration granted to Arthur Cooper, this seventeenth day of September, A.D. 1883.

AUGUSTUS LOFTUS.

---

REPORT.

Sir,

We do ourselves the honor to report, in reply to your B.C. of the 13th ultimo, that we are of opinion that the prayer of Mr. Arthur Cooper, for the registration of an invention entitled "Improvements in the treatment of Iron or Steel Ingots" may be granted, in terms of the specification and drawings accompanying his claim.

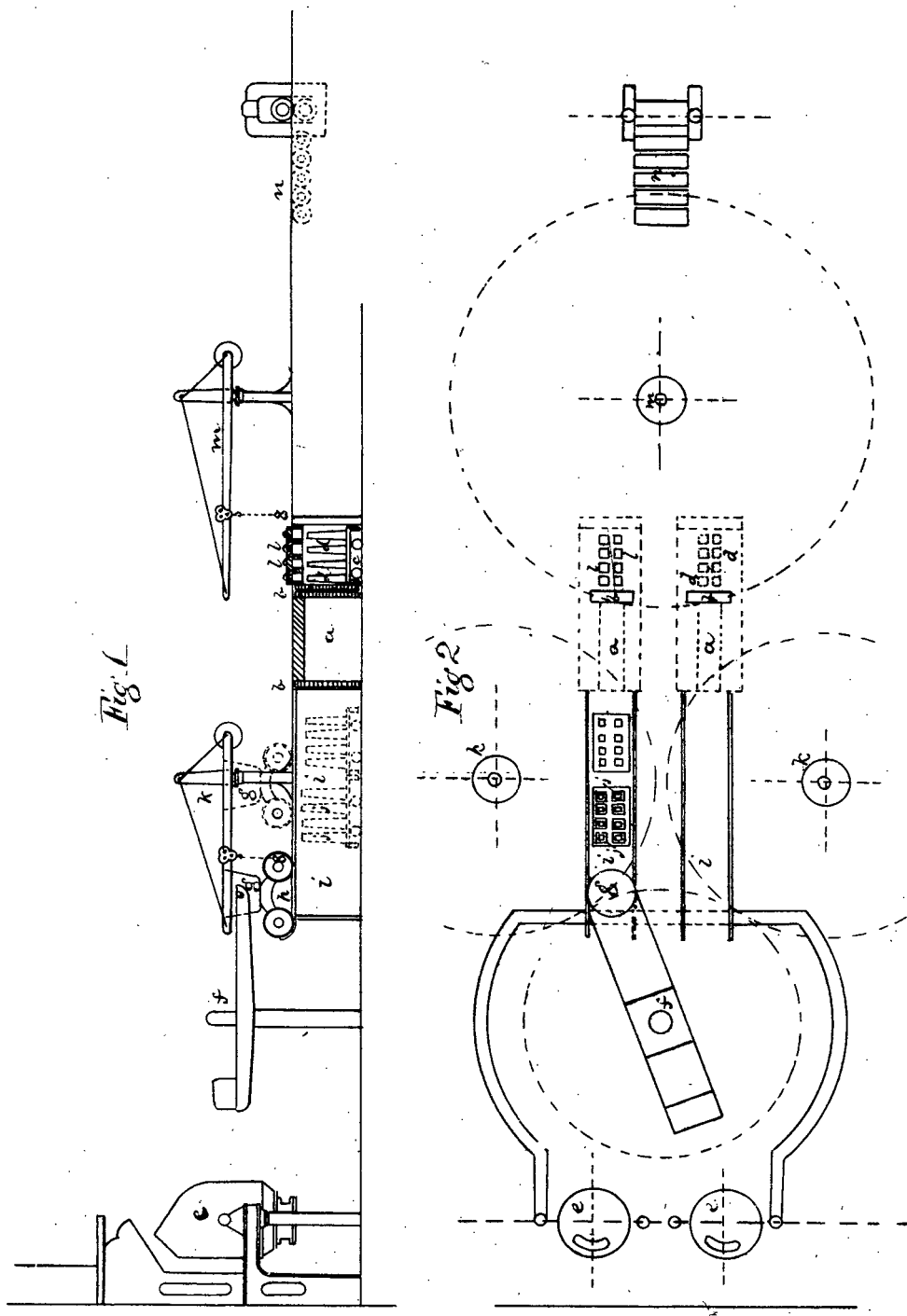
Sydney, 2 August, 1883.  
We have, &c.,

E. O. MORIARTY.  
JOHN WHITTON.

The Under Secretary of Justice.

---

[Drawings—two sheets.]

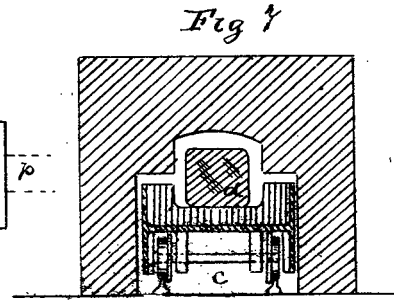
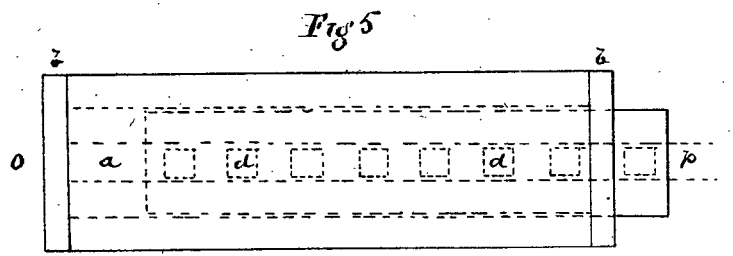
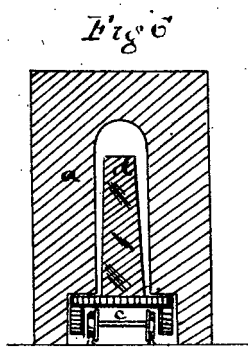
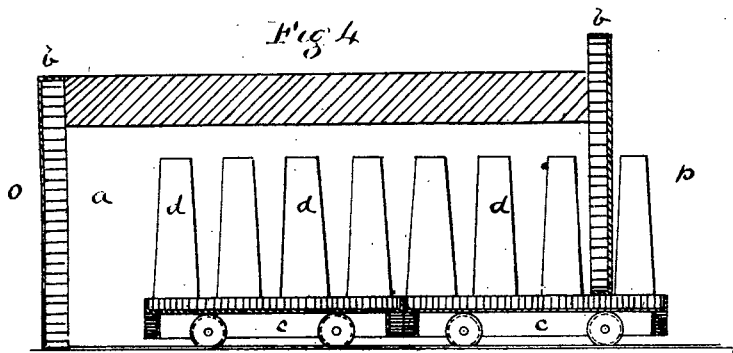
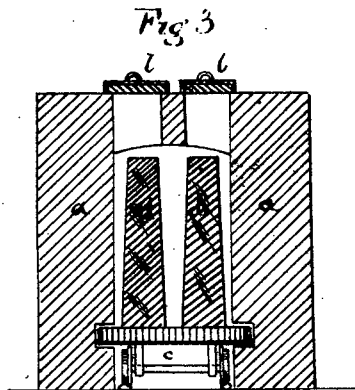


*This is the Sheet of Drawings marked B. referred to in the annexed Letters of Registration granted to Arthur Cooper, this 17<sup>th</sup> day of September A. D. 1883.*

*Augustus Loftus.*

C.

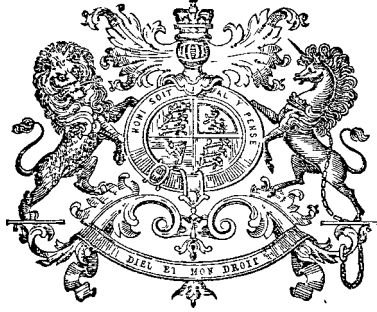
1309.



*This is the Sheet of Drawings marked C. referred to in the annexed Letters of Registration granted to Arthur Cooper this 17<sup>th</sup> day of September A. D. 1883.*

*Augustus Loftus.*






---

A.D. 1883, 17th September. No. 1310.

---

IMPROVEMENTS ON AND RELATING TO STOCK CARS.

---

LETTERS OF REGISTRATION to Stephen Preston Tallman, for Improvements on and relating to Stock Cars.

[Registered on the 18th day of September, 1883, in pursuance of the Act 16 Vic No. 24]

---

BY HIS EXCELLENCY THE RIGHT HONORABLE SIR AUGUSTUS WILLIAM FREDERICK SPENCER LOFTUS (commonly called LORD AUGUSTUS LOFTUS), Knight Grand Cross of the Most Honorable Order of the Bath, a Member of Her Majesty's Most Honorable Privy Council, Governor and Commander-in-Chief of the Colony of New South Wales and its Dependencies.

TO ALL TO WHOM THESE PRESENTS SHALL COME, greeting :

WHEREAS STEPHEN PRESTON TALLMAN, of the Town of Dunellen, in the county of Middlesex, and State of New Jersey, gentleman, hath by his Petition humbly represented to me that he is the author or designer of a certain invention or improvement in manufactures, that is to say, of an invention entitled "Improvements on and relating to Stock Cars," which is more particularly described in the specification and the sheet of drawings which are hereunto annexed; and that he, the said Petitioner, hath deposited with the Honorable the Treasurer of the said Colony of New South Wales, the sum of Twenty Pounds sterling, for defraying the expense of granting these Letters of Registration, as required by the Act of Council, sixteenth Victoria, number twenty-four; and hath humbly prayed that I would be pleased to grant Letters of Registration, whereby the exclusive enjoyment and advantage of the said invention or improvement might be secured to him for a period of fourteen years: And I, being willing to give encouragement to all inventions and improvements in the arts or manufactures which may be for the public good, and having received a report favourable to the prayer of the said Petition from competent persons appointed by me to examine and consider the matters stated therein and to report thereon for my information, am pleased, with the advice of the Executive Council, and in exercise of the power and authority given to me by the said Act of Council, to grant, and do by these Letters of Registration grant unto the said Stephen Preston Tallman, his executors, administrators, and assigns, the exclusive enjoyment and advantage of the said invention or improvement for and during the term of fourteen years from the date hereof, to have, hold, and exercise unto the said Stephen Preston Tallman, his executors, administrators, and assigns, the exclusive enjoyment and advantage thereof, for and during and unto the full end and term of fourteen years from the date of these presents next and immediately ensuing, and fully to be complete and ended: Provided always, that if the said Stephen Preston Tallman shall not, within three days after the granting of these Letters of Registration, register the same in the proper office in the Supreme Court, at Sydney, in the said Colony of New South Wales, then these Letters of Registration, and all advantages whatsoever hereby granted, shall cease and become void.

In witness whereof, I have hereunto set my sign manual, and have caused the present Letters of Registration to be sealed with the seal of the said Colony of New South Wales, at Government House, Sydney, in New South Wales, this seventeenth day of September, in the year of our Lord one thousand eight hundred and eighty-three.

[L.s.]

AUGUSTUS LOFTUS.

*Improvements on and relating to Stock Cars.*

## SPECIFICATION.

TO ALL WHOM IT MAY CONCERN: BE it known that I, Stephen Preston Tallman, a citizen of the United States, residing at Dumellen, in the county of Middlesex, and State of New Jersey, one of the United States of America, gentleman, have invented certain new and useful improvements on and relating to Stock Cars, of which the following is a full, clear, and exact specification.

My invention relates to cars for transporting cattle and live stock of all kinds, but particularly horned cattle. The car has a door in each side near the end of the car, and shallow stalls to house the heads of the animals, arranged half on each side of the car, and partition gates, pivoted at their bottoms to fixed partitions between the shallow stalls, and arranged to turn up into the same so as to leave a free passage for the animals in loading. The middle partition in the car is hinged to the side of the car, so as to be swung round out of the way in loading, so as to leave a freer passage way at the middle of the car, whereby the animals may be loaded wholly from either side of the car. Water and feed troughs are provided, and a water reservoir is arranged in the roof of the car and adapted to receive water from the tanks along the line of the railway, and convey it to the troughs.

The car has other novel features, which will be referred to hereinafter.

Referring to the drawings, figure 1 is a sectional plan of the car, provided with my improvements the section being taken on line 1, 1, in figures 2 and 3; figure 2 is a cross-section, taken on the line 2, 2, in figure 1; and figure 3 is a similar section, on line 3, 3, in figure 1. These sections are drawn to a scale twice that of figure 1, and the points from which the sections are viewed are indicated by the arrows in figure 1. Figure 4 is a detached view, much enlarged, of the elastic fastening, J, for the free end of the partition gate when down.

A, represents the car-body in general, it being, by preference, provided with longitudinally-slotted sides to admit air. B, B are double or twin posts, arranged at the ends of the fixed partitions which part off the sides of the car into shallow stalls. These partitions are formed of slats, *a, a*, which extend from the posts, B, to the sides of the car, as shown in figures 2 and 3. The members of the posts, B, are set so as to leave a space of about an inch between them, and hinged between them at about a foot from the car floor is the partition-gate, C. This gate is composed of flexible slats, *r, r, g*, preferably of elastic wood, secured to vertical end-stiles. Each gate is pivoted in its post at its lower corner, and is capable of being turned up edgewise through the post in the manner of the blade of a jack-knife, and is so proportioned with reference to the shallow stalls, that, when turned up on end therein, it will be out of the way and occupy no appreciable room in the car. In order to give the gates additional elasticity, so that they may yield somewhat to the pressure brought upon them when the animals are thrown against them in the jolting of the car, I provide each gate with one or more spring fastenings, J, one of which is shown detached, and partly in section, in figure 4. These fastenings, generally two for each gate, are fixed to the sides of the car so as to receive the stile at the free end of the gate when the latter is turned down, and each consists of a rounded cast-metal block, with a central recess, *l*, to receive the gate-stile, and jaws, *m, m*, formed thereby, to embrace the stile. The stile, shown in dotted lines, in figure 4, fits loosely in recess, *l*, but is embraced, elastically, by convex blocks, *n*, backed by springs, *o*, on rods, *p*. These are embraced in recesses in the inner faces of the jaws, as clearly shown. The ends of the gates, when down, rest on strips, *t*, on the side of the car, shown in figure 3.

D D are the doors of the car, which are arranged to slide, in opening and closing, in the usual way with such doors. As the door is as wide as two of the stalls, it is necessary to provide a swinging or removable post to receive and support the end of the last gate nearest the end of the car, as this gate cannot be secured to the door itself, in the same manner as it can be to the side of the car. This arrangement is best shown in figure 2, where B, illustrates a twin-post, hung at *b* to the roof, and arranged to engage cleats, *d*, on the floor when erect. When the end gate is turned down, its free end engages the space between the members of this post, and rests on a pin, *e*, in said post. To prevent the gate from being lifted by the cattle, a gravity or spring detent, *g*, is hung in the post which takes over its top rail, as shown, where the post is broken away in figure 2. The dotted lines show how this post may be hung up out of the way when not in use, a hook on the post, B, being provided to engage an eye, *c*, on the post, E.

To prevent the cattle from jumping over or on the gates, I prefer to provide fixed bars, I, arranged to extend across the car over the gates, and at the proper height. That at the partition, which corresponds to post E (see figure 2), I have lettered, I'. This bar is hinged to post, B, and when not in use hangs down beside the latter; but when in use it is raised and secured to post, E, by a pin, *s*.

In order to permit a free passage at the middle of the car, where the space is somewhat lessened, I prefer to hinge the middle partition of the car so that it may be swung around out of the way. This partition I have arbitrarily designated by the letter X, in figure 1, where it is shown turned part way around in towards the side of the car. Figure 3, shows the construction of this partition, which is formed like the others, except in respect of a hinging post, G, next the side of the car, cleats and braces, *i, i*, to stiffen it, and hinges, *h, h*.

The post, B, of this partition, is not, of course, fixed, but is provided with bolts, *j, j*, at top and bottom, to engage sockets in the car when the post is in place. The post, G, is provided with a pin, *k*, for the gate, C, to rest against when turned up, so that it may not touch the feed-trough and side of the car, and interfere with the swing of the partition.

H H are the water and feed troughs, arranged on the floor of the car, and, L, is the water-receiver, placed in the roof of the car under the foot-board, M, and connected with the troughs by pipes, *r, r*. This receiver and its pipes are shown in dotted lines in figure 1. The foot-board has a hinged section where it passes over the receiver, so that access may be had to the receiver in supplying water to the troughs.

The animals are driven in at the door, and after each is placed, the gate, C, is let down, the last stalls to be filled being the two opposite the door of admission. The post, E, and bar, I', are set and fixed, the animals driven in, and the door closed. The shallow stalls house the heads of the animals, and the yielding gates separate their bodies. The animals on one side of the car all face one way, and as half the animals in the car face each way, the load in the car is admirably balanced.

I have shown a car fitted to carry sixteen head of cattle, and this is the preferred arrangement, but I do not limit myself in this respect.

Where

*Improvements on and relating to Stock Cars.*

Where half the animals are to be loaded from each side of the car, the middle partition, X, need not be disturbed, and this middle gate may be let down before loading. The feed may, if desired, be put in through a hinged flap-door at the side over the trough, but this is neither new nor important.

Having thus described my invention I claim,—

1. A stock-car provided with shallow stalls arranged to house the heads of the animals, and partition gates, to separate their bodies, arranged to turn up on edge into said stalls, substantially as shown.
2. As a partition for separating the bodies of the animals in the car, an elastic gate arranged to be turned up out of the way, as described.
3. The elastic fastenings for the gate when it is turned down, substantially as described.
4. The post, E, hinged at its upper end and arranged to be turned up out of the way, substantially as set forth.
5. The hinged middle partition, X, arranged to be turned out of the way so as to enlarge the passage through the car, substantially as set forth.
6. The bars, I, arranged over the gates, C, to prevent the animals from jumping on or over the latter, substantially as set forth.
7. A stock-car, having its doors arranged on opposite sides of the car, near its ends, and the shallow stalls arranged, half on each side of the car, as shown, for convenience in loading and trimming the load in the car, as set forth.
8. The stock-car, provided with a feed-trough, H, on each side of the car, and extending half the length of the same, and with an elongated water-receiver, L, in its roof, said receiver being connected with the troughs, H, by pipes, r, r, as shown and specified.
9. A stock-car, as a whole, constructed substantially as herein shown and described.

Witnesses—

W. A. STEEL.  
D. M. KITCHELL.

STEPHEN PRESTON TALLMAN.

In witness whereof, I, the said Stephen Preston Tallman, have hereto set my hand and seal, this thirteenth day of June, one thousand eight hundred and eighty-three.

Witness—

FRED. WALSH,  
Messrs. Edwd. Waters', Patent Office, Sydney.

STEPHEN PRESTON TALLMAN.

(By his Attorney, Wm. Ed. Wilson).

This is the specification referred to in the annexed Letters of Registration granted to Stephen Preston Tallman, this seventeenth day of September, A.D. 1883.

AUGUSTUS LOFTUS.

---

REPORT.

Sir,

Sydney, 9 July, 1883.

In reference to your B.C. communication of 15th ultimo, forwarding a Petition for Letters of Registration for an invention entitled "Improvements in and relating to Stock Cars," from Mr. Stephen Preston Tallman, we have the honor to inform you that having examined the specification and plans accompanying the Petition, we recommend that Letters of Registration should be issued to the Petitioner for the invention, as described in the specification, &c., attached to his Petition.

We have, &c.,

JOHN WHITTON.  
E. O. MORIARTY.

The Under Secretary of Justice.

---

[Drawings—one sheet.]

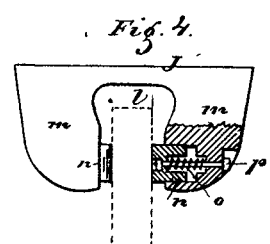
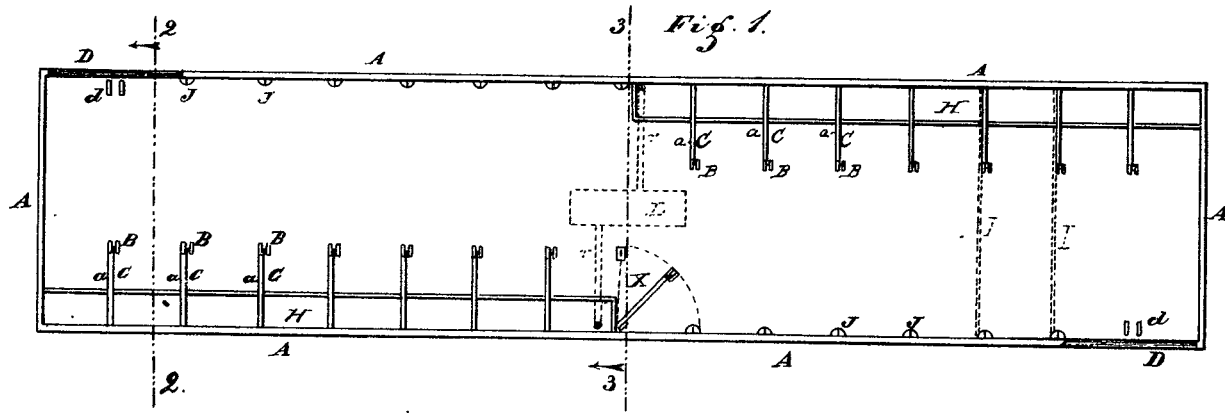
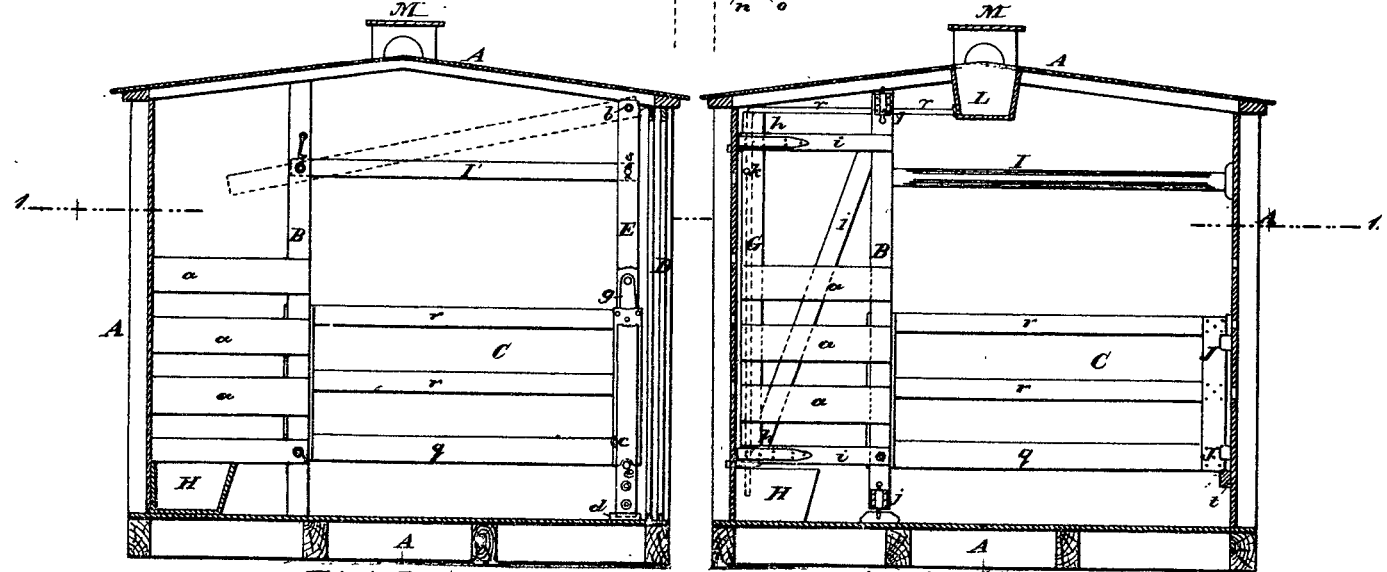


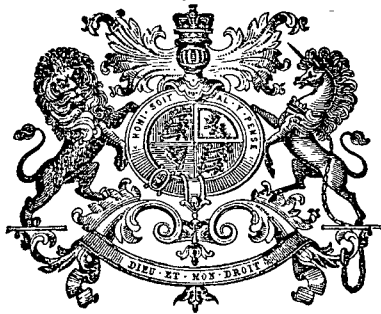
Fig. 2.

Fig. 3.



*This is the Sheet of Drawings referred to in the annexed  
 Letters of Registration granted to Stephen Preston  
 Tallman the 17<sup>th</sup> day of September A.D. 1883.  
 Augustus Loftus.*

Sig: 35.



A.D. 1883, 17th September. No. 1311.

AN IMPROVEMENT IN EARTH SCOOPS.

LETTERS OF REGISTRATION to James Hutchings, for an Improvement in Earth Scoops.

[Registered on the 18th day of September, 1883, in pursuance of the Act 16 Vic. No. 24.]

BY HIS EXCELLENCY THE RIGHT HONORABLE SIR AUGUSTUS WILLIAM FREDERICK SPENCER LOFTUS (commonly called LORD AUGUSTUS LOFTUS), Knight Grand Cross of the Most Honorable Order of the Bath, a Member of Her Majesty's Most Honorable Privy Council, Governor and Commander-in-Chief of the Colony of New South Wales and its Dependencies.

TO ALL TO WHOM THESE PRESENTS SHALL COME, greeting :

WHEREAS JAMES HUTCHINGS, of 247, Elizabeth-street, Melbourne, in the Colony of Victoria, Agricultural Implement Manufacturer, hath by his Petition humbly represented to me that he is the Assignee of Amos Underwood, who is the author or designer of a certain invention or improvement in manufactures, that is to say, of an invention entitled "An Improvement in Earth Scoops," which is more particularly described in the specification and the sheet of drawings which are hereunto annexed ; and that he, the said Petitioner, hath deposited with the Honorable the Treasurer of the said Colony of New South Wales the sum of Twenty Pounds sterling for defraying the expense of granting these Letters of Registration, as required by the Act of Council, sixteenth Victoria number twenty-four ; and hath humbly prayed that I would be pleased to grant Letters of Registration whereby the exclusive enjoyment and advantage of the said invention or improvement might be secured to him for a period of fourteen years : And I, being willing to give encouragement to all inventions and improvements in the arts or manufactures which may be for the public good, and having received a report favourable to the prayer of the said Petition from competent persons appointed by me to examine and consider the matters stated therein and to report thereon for my information, am pleased, with the advice of the Executive Council, and in exercise of the power and authority given to me by the said Act of Council, to grant, and do by these Letters of Registration grant unto the said James Hutchings, his executors, administrators, and assigns, the exclusive enjoyment and advantage of the said invention or improvement, for and during the term of fourteen years from the date hereof ; to have, hold, and exercise unto the said James Hutchings, his executors, administrators, and assigns, the exclusive enjoyment and advantage thereof for and during and unto the full end and term of fourteen years from the date of these presents next and immediately ensuing, and fully to be complete and ended : Provided always, that if the said James Hutchings shall not, within three days after the granting of these Letters of Registration, register the same in the proper office in the Supreme Court, at Sydney, in the said Colony of New South Wales, then these Letters of Registration and all advantages whatsoever hereby granted, shall cease and become void.

In witness whereof, I have hereunto set my sign manual, and have caused the present Letters of Registration to be sealed with the seal of the said Colony of New South Wales, at Government House, Sydney, in New South Wales, this seventeenth day of September, in the year of our Lord one thousand eight hundred and eighty-three.

[L.S.]

AUGUSTUS LOFTUS.

*An Improvement in Earth Scoops.*

SPECIFICATION of JAMES HUTCHINGS, of 247, Elizabeth-street, Melbourne, in the Colony of Victoria, Agricultural Implement Manufacturer, the Assignee of Amos Underwood, of Benalla, in the Colony of Victoria, farmer, the inventor of an invention entitled "An Improvement in Earth Scoops."

THIS invention relates to those kinds of earth scoops which are carried on skids or wheels, and which discharge their contents by turning over. Its object is to prevent the scoop turning over except when the operator desires it to do so, and so to prevent accidents from its turning over when it is not expected to do so. It consists in lengthening the metal bars, into the forked end of which the butt end of the handles are attached, so as to make them project beyond the axle of the scoop, and to connect such extension by a slack connection to the front framing of the machine.

This is clearly shown in my drawings, in which figure 1 shows plan, and figure 2 side elevation of an earth scoop carried on wheels and constructed according to this invention. Figure 3 shows side elevation of part of same when the scoop is in the act of tipping, and figure 4 back view of the scoop itself. A is the scoop, B the handles, C the metal bars to which the butt ends of the handles are attached, and C<sup>1</sup> the extension thereof, which, together with the slack (chain) connection, D, connecting it to the front framing, E, forms the subject matter of this invention. F F are the side wheels, and F<sup>1</sup> the front wheel. G G are the slots in plates, G<sup>1</sup>, into which the metal bars, C, of the handles, B, are placed when the machine is scooping (see figures 2 and 3), and under which they are placed when the scoop is about to tip.

The mode of operation is as follows:—When the machine is travelling to its work, it is in the position shown in figure 2. When about to scoop, the handles, B, are raised more or less, according to the depth to which it is desired to work—the greater the depth the higher the handles are raised—said handles always remaining in the slots, G, as in figure 4; but when the scoop is full, it is removed to the place of discharge, the handles are removed sideways out of the slots and placed underneath the plates, G<sup>1</sup>, so as to assist in forcing the nose of the scoop into the ground, and in giving it an impetus towards turning over, which it cannot do so long as the handles remain in the slots, G. There must be some little play to the end of the extension of the handles, or they would not be capable of directing the working of the scoop; and this play is provided for by the chain, D, which is one form, and I think the most convenient of my slack connection.

Having thus described the nature of my invention and the manner of performing same, I would have it understood that I do not confine myself to the precise details shown in my drawings and described in this my specification, so long as the essence and character of my invention be retained;—for instance, skids may be used instead of wheels, the shape and size of all the parts of the machine may be varied, and the extension of the metal bars may be lengthened or shortened at will, and so with the chain connections; but what I believe to be new, and therefore claim as my improvement in earth scoops supported on wheels or skids, is—

Extending the metal bars at the butt end of the handles and connecting such extensions to the front framing of the machine by slack connections, substantially as herein described and explained.

In witness whereof, I, the said James Hutchings, have hereunto set my hand and seal, this twenty-third day of June, one thousand eight hundred and eighty-three.

Witness—

EDWD. WATERS,  
Melbourne, Patent Agent.

JAMES HUTCHINGS.

This is the specification referred to in the annexed Letters of Registration granted to James Hutchings, this seventeenth day of September, A.D. 1883.

AUGUSTUS LOFTUS.

### REPORT.

Sir,

We do ourselves the honor to report, in reply to your B.C. of the 2nd ultimo, No. 83-8,160, that we are of opinion that the prayer of Mr. James Hutchings, for Letters of Registration for an invention entitled "An Improvement in Earth Scoops," may be granted in terms of his specification and drawing.

We have, &c.,

E. O. MORIARTY.  
JOHN WHITTON.

The Under Secretary of Justice.

Sydney, 6 August, 1883.

This is the sheet of Drawings referred to in the undered  
Letters of Registration granted to James Hutchings, this  
17<sup>th</sup> day of September A. D. 1883.  
Augustus Loftus.

PHOT-DUPL. BY THE GOVT. PRINTING OFFICE  
SYDNEY, NEW SOUTH WALES.

Fig. 2.

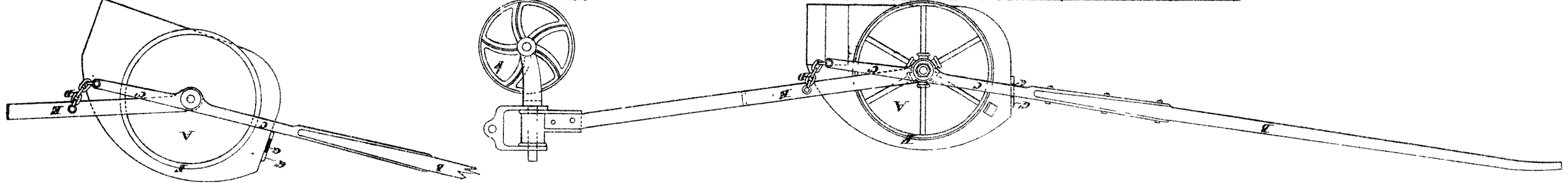


Fig. 3.

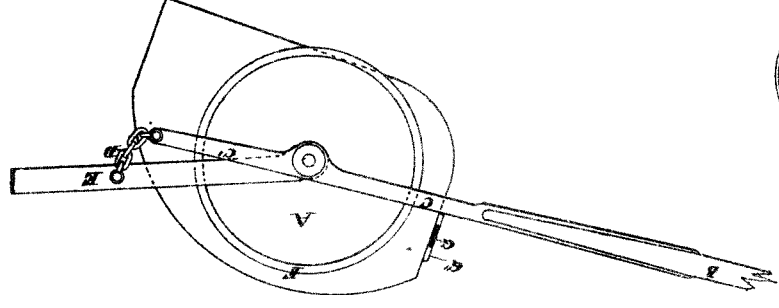


Fig. 1.

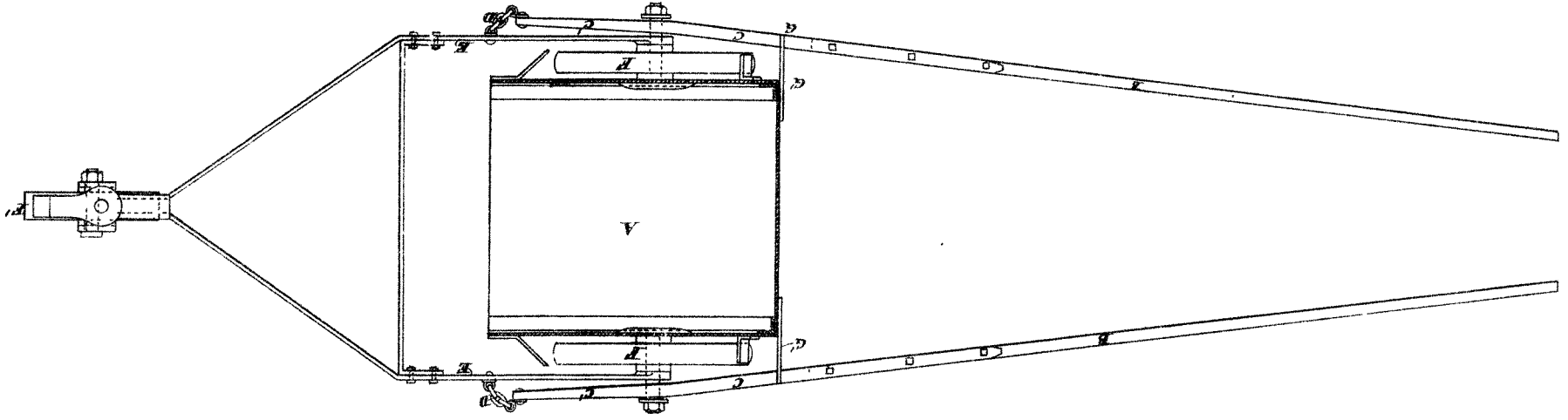
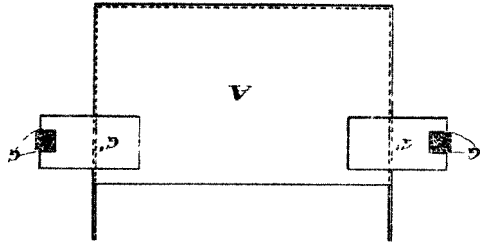


Fig. 4.



**J. HUTCHINGS' PATENT**



A.D. 1883, 17th September. No. 1312.

**IMPROVEMENTS IN THE MANUFACTURE OF GROOVED TYRES FOR WHEELS  
AND IN THE FASTENING OF INDIA-RUBBER OR OTHER YIELDING MATERIAL  
THEREIN.**

LETTERS OF REGISTRATION to William Hassalwood Carmont, for improvements in the manufacture of Grooved Tyres for Wheels, and in the fastening of India-rubber or other yielding material therein.

[Registered on the 18th day of September, 1883, in pursuance of the Act 16 Vic. No. 24.]

BY HIS EXCELLENCY THE RIGHT HONORABLE SIR AUGUSTUS WILLIAM FREDERICK SPENCER LOFTUS (commonly called LORD AUGUSTUS LOFTUS), Knight Grand Cross of the Most Honorable Order of the Bath, a Member of Her Majesty's Most Honorable Privy Council, Governor and Commander-in-Chief of the Colony of New South Wales and its Dependencies.

TO ALL TO WHOM THESE PRESENTS SHALL COME, greeting :

WHEREAS WILLIAM HASSALWOOD CARMONT, of Manchester, in the county of Lancaster, England, hath by his Petition humbly represented to me that he is the author or designer of a certain invention or improvement in manufactures, that is to say, of an invention entitled "Improvements in the manufacture of Grooved Tyres for Wheels, and in the fastening of India-rubber or other yielding material therein," which is more particularly described in the specification and the sheet of drawings which are hereunto annexed; and that he, the said Petitioner, hath deposited with the Honorable the Treasurer of the said Colony of New South Wales the sum of Twenty Pounds sterling for defraying the expense of granting these Letters of Registration, as required by the Act of Council, sixteenth Victoria number twenty-four; and hath humbly prayed that I would be pleased to grant Letters of Registration, whereby the exclusive enjoyment and advantage of the said invention or improvement might be secured to him for a period of fourteen years: And I, being willing to give encouragement to all inventions and improvements in the arts or manufactures which may be for the public good, and having received a report favourable to the prayer of the said Petition, from competent persons appointed by me to examine and consider the matters stated therein and to report thereon for my information, am pleased, with the advice of the Executive Council, and in exercise of the power and authority given to me by the said Act of Council, to grant and do by these Letters of Registration grant unto the said William Hassalwood Carmont, his executors, administrators, and assigns, the exclusive enjoyment and advantage of the said invention or improvement for and during the term of fourteen years from the date hereof; to have, hold, and exercise unto the said William Hassalwood Carmont, his executors, administrators, and assigns, the exclusive enjoyment and advantage thereof, for and during and unto the full end and term of fourteen years from the date of these presents next and immediately ensuing, and fully to be complete and ended: Provided always, that if the said William Hassalwood Carmont, shall not, within three days after the granting of these Letters of Registration, register the same in the proper office in the Supreme Court, at Sydney, in the said Colony of New South Wales, then these Letters of Registration, and all advantages whatsoever hereby granted, shall cease and become void.

In witness whereof, I have hereunto set my sign manual, and have caused the present Letters of Registration to be sealed with the seal of the said Colony of New South Wales, at Government House, Sydney, in New South Wales, this seventeenth day of September, in the year of our Lord one thousand eight hundred and eighty-three.

[L.S.]

AUGUSTUS LOFTUS.



*Improvements in the Manufacture of Grooved Tyres.*

TO ALL TO WHOM THESE PRESENTS SHALL COME, I, WILLIAM HASSALWOOD CARMONT, of Manchester, in the county of Lancaster, England, consulting engineer, send greeting :

WHEREAS I am desirous of obtaining Letters of Registration for the Colony of New South Wales securing unto me Her Majesty's special license that I, my executors, administrators, and assigns, and such others as I or they at any time agree with, and no others, should and lawfully might, from time to time, and at all times during the term of fourteen years next and immediately after the date of the said Letters of Registration, make, use, exercise, and vend within the said Colony of New South Wales an invention for "Improvements in the manufacture of grooved tyres for wheels, and in the fastening of India-rubber or other yielding material therein"; and whereas in order to obtain such Letters of Registration, I must, by an instrument or specification in writing under my hand and seal, particularly describe and ascertain the nature of the said invention, and in what manner the same is to be performed. Now know ye, that the nature of the said invention and the manner in which the same is to be performed is particularly described and ascertained in and by the following statement in writing, that is to say :—

The principal object of this invention is to manufacture tyres of iron, or other metal grooved in the form of a dovetail or other undercut section for the purpose of holding or securing therein rings or bands of India-rubber or other yielding substance.

According to the first part of my invention when it is required to produce a dovetail section, I first roll a section of metal similar to ordinary channel iron with the sides *a a* vertical, but with the lower surface of the base *b b* of the section concave, the upper surface of the base being necessarily convex to a similar degree, as shown at figure 1, in the annexed drawing, or slightly inclined outwards, as shown on figure 2. In each case the angle formed at the point *c c* must be rolled to the actual angle required for the finished section.

I then pass the section (either figure 1 or figure 2) through a groove of the necessary shape in rolls that flatten the base, causing the upper edges of the tyre or channel to approach one another, as shown at figure 3, the upper roll being of a plain cylindrical form, and the lower roll being of a sufficient width to enter between the points *d d*, as shown by the dotted lines or *vice versa*; the sides of the grooves being bevilled to the required angle.

Having rolled a bar of iron of this section (figure 3) of a sufficient length, I bend it round into a circle in the usual way, weld the ends together, and attach it to the felloe of a wheel in the ordinary manner, or the tyre may be rolled weldless if preferred.

I now take a length of India-rubber of a dovetail section, with a rounded apex and a flat base, and by pressure I force it into the dovetail-groove of the wheel, as shown at figure 4. This India-rubber before being forced in, is wider than the dovetail groove of the tyre, as shown by the dotted lines, and being thus compressed it will be held perfectly firm without any cement, and cannot be torn from the groove by any violence to which an ordinary carriage wheel is likely to be subjected; and if at any time a part of the rubber becomes damaged, any length can be cut out, and a fresh piece inserted at a slight cost without interfering with the remaining portion.

When it is desired to manufacture a grooved tyre with vertical sides, but with an undercut lip on each side, as at *f f*, figure 6, I first roll it to the section shown at figure 5, with the base concavo-convex as before; but the angle at *g g*, a right angle, and then by flattening the base, as in the former case, I bring it into the form shown at figure 6.

The second part of my invention relates to certain modifications of the above, whereby I am enabled to manufacture metal of the dovetail or other undercut section required for the above purpose, with both angles sharply rolled, and without any necessity for bending or curving the base.

According to one modification of this part of my invention, I propose to roll the two angles separately, which I am enabled to do by my particular method of manufacture, and by the peculiar construction of the rolls which I employ.

I first roll an ordinary form of channel iron or other metal, of about the section required, but with the sides vertical, and either parallel, or slightly tapered in the usual manner with the base parallel to the axis of the roller, as shown at figure 7.

For the next part of the operation I construct the rolls as follows :—I turn a certain portion of the lower roll (for a width about equal to the widest part of the outer section required) to a conical form tapering towards the axle (say) from left up to right, as at *h h*, figure 8, to such a taper that the side of the cone forms, with the vertical edge of the groove at *i i*, the exact angle required at the inside of the dovetail on the left side. The depth of the circumferential groove is equal to the depth of the side *a' a'* of the metal, and the left side *i i* of the groove corresponds with the outer form to be given to this side of the metal.

The upper roll is made with a reversed conical surface *k k*, (from left to right), the width of which will be determined by a line drawn parallel to the inner surface of the side *a' a'*, and falling just within the inner upper edge of the square side *a' a'*.

The depth and form of the circumferential groove *l l* will correspond with the outside form of the said square side *a' a'*, so that this side of the metal is entirely supported, whilst the side *a'* is being formed.

It will now be obvious that if a length of ordinary square-sided channel iron or metal, figure 7, be slightly tilted over towards the left, and passed through these conical grooves, it will be rolled into the dovetail section required, so far as concerns the left-hand side, and about three quarters to five-sixths of the base.

I have a second similar conical groove prepared, but tapered in the reverse direction (*see* figure 9), and by tilting the partly rolled iron or metal over to the right, and passing it through the second groove, the remaining angle of the dovetail will be formed, and the required section, similar to figure 3, will be produced by positive rolling.

According to another modification, I first roll channel iron or metal the form of three sides of a rhomboid (*see* figure 10) by means of the same kind of tapered rollers, as those above described (figure 8), the acute angle between the base, and one of the sides being equal to the angle of the dovetail required.

*Improvements in the Manufacture of Grooved Tyres.*

On rolling the metal again in a reversed conical groove, as at figure 9, the second angle of the dovetail is produced as before.

A further modification of the invention consists in first rolling a square section channel iron or steel with a flat base (figure 7), and then bending over the sides to the required dovetail, by means of rolls so constructed as to hold the base flat, whilst the sides are being bent over (*see* figure 11.)

For this purpose I construct the rolls as follows:—The bottom roll is made cylindrical, and either quite plain, or with a circumferential depression *m m* corresponding with the breadth and depth of the base *b b*. The upper roll is made with a central collar or solid cylinder *n n* between two grooves *o o*. The width of the collar *n n* is equal to that of the mouth of the dovetail (as shown in dotted lines), and the diameter of this central collar or cylinder is such that it rolls on the inside of the base *b b* keeping it flat, and preventing the rise of the corners, whilst the sides are being bent in. The depth of the grooves is equal to the height of the sides of the dovetail-channel, and the outside of the grooves *o o* is coned or bevilled to the outer form of the dovetail section required, so that the whole section, with the exception of the inside corners, is supported during the operation of bending over the sides, or it may be rolled in the reversed position, as shown at figure 3.

As the base *b b* when finished must be perfectly square at the corners *m m*, the depth of the side grooves *o o* must be just sufficient to put a downward thrust upon the upper edge of the sides *a' a'*, so as to prevent the corners of the base from rising.

When it is desired to manufacture a dovetail section with vertical sides, I roll the metal in the ordinary way to the form shown at figure 12, then by passing it through a square-sided groove, bend the sides in, as shown by dotted lines.

The lengths of dovetail section metal produced by either of these modifications will require to be bent to a circle by the ordinary bending rolls, and the ends brought together, and welded to form a wheel-tyre, as before described.

It will, however, be evident that weldless tyres can also be made on the same principle.

## CLAIMS.

I claim as my invention:—

Firstly—The art of manufacturing grooved tyres for wheels of a dovetail, or other similarly undercut form by first rolling the metal with the base of the channel of a concavo-convex form, and with the sides at the angles required, the sides being either vertical or inclined outwards, and afterwards bringing the upper edges of the sides together by flattening the base between suitable rolls substantially, as hereinbefore described, with reference to the first part of the invention.

Secondly—I claim the art of manufacturing such tyres without bending the base by means of any of the modifications described with reference to the second part of the invention; and

Thirdly—I claim, as a new manufacture, a grooved metallic tyre of a dovetail or other undercut section, rolled as above described, into which an India-rubber tyre of suitable form is compressed, and firmly fixed without cement or other extraneous means substantially in the manner hereinbefore described.

In witness whereof, I, the said William Hassalwood Carmont, have hereunto set my hand and seal, the eighth day of May, in the year of our Lord one thousand eight hundred and eighty-three

W. H. CARMONT.

Signed and sealed in the presence of,—

GEORGE DAVIS,  
Office of Patents,  
4 St. Ann's Square, Manchester.

This is the specification referred to in the annexed Letters of Registration granted to William Hassalwood Carmont, this 17th day of September, A.D. 1883.

AUGUSTUS LOFTUS.

## REPORT.

Sir,

Sydney, 2 August, 1883.

We do ourselves the honor to report, in reply to your B.C. of the 2nd ultimo, that we are of opinion that the prayer of Mr. William H. Carmont, for Letters of Registration for an invention entitled "Improvements in the manufacture of Grooved Tyres for Wheels," may be granted in terms of his specification and drawing accompanying his claim.

We have, &c.,  
E. O. MORIARTY.  
JOHN WHITTON.

The Under Secretary of Justice.

FIG: 1.

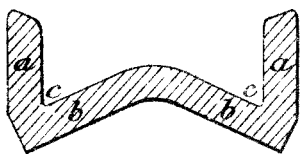


FIG: 2.

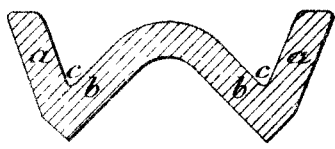


FIG: 8.

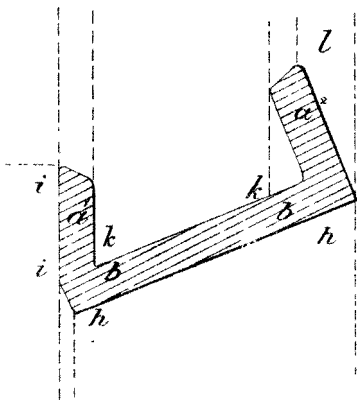


FIG: 9.

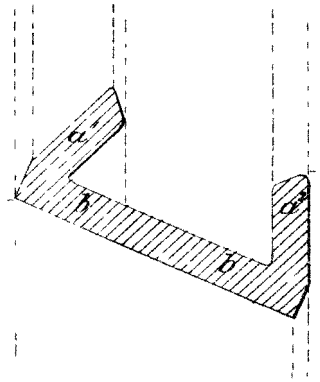


FIG: 3.

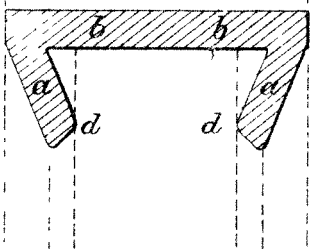


FIG: 4.

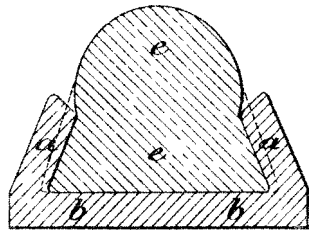


FIG: 7.

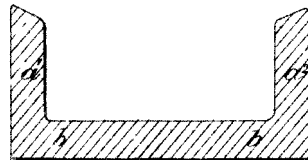


FIG: 10.

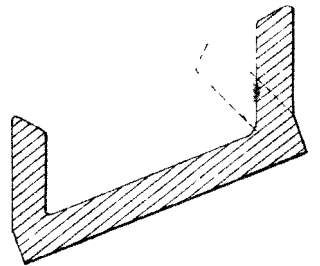


FIG: 5.

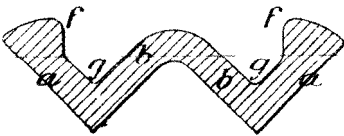


FIG: 6.

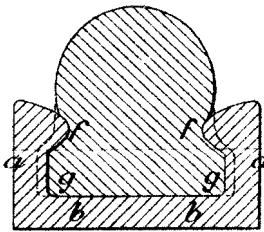


FIG 11

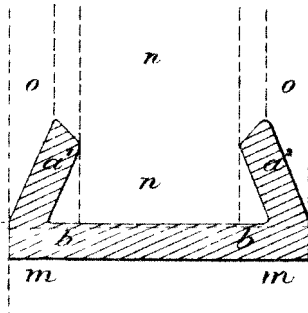
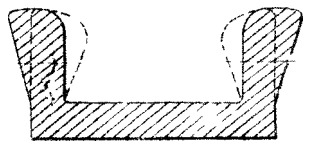
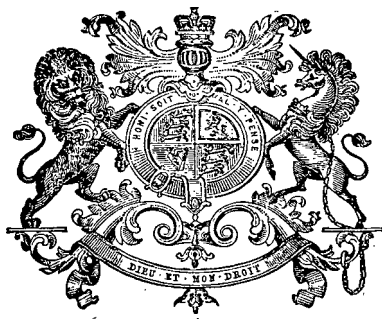


FIG 12



*This is the Sheet of Drawings referred to in the annexed Letters of Registration granted to William Hassalwood Carmont this 17<sup>th</sup> day of September A.D. 1883.*



A.D. 1883, 20th September. No. 1313.

IMPROVEMENT IN ROLLING STOCK FOR BREAK OF GAUGE RAILWAYS, &c.

LETTERS OF REGISTRATION to John William Hall Hullett, for an Improvement in Rolling Stock for Break of Gauge Railways and Tramways.

[Registered on the 21st day of September, 1883, in pursuance of the Act 16 Vic. No. 24.]

BY HIS EXCELLENCY THE RIGHT HONORABLE SIR AUGUSTUS WILLIAM FREDERICK SPENCER LOFTUS (commonly called LORD AUGUSTUS LOFTUS), Knight Grand Cross of the Most Honorable Order of the Bath, a Member of Her Majesty's Most Honorable Privy Council, Governor and Commander-in-Chief of the Colony of New South Wales and its Dependencies.

TO ALL TO WHOM THESE PRESENTS SHALL COME, greeting:

WHEREAS JOHN WILLIAM HALL HULLETT, of Port Augusta, in the Province of South Australia, engineer, hath by his Petition humbly represented to me that he is the author or designer of a certain invention or improvement in manufactures, that is to say, of an invention entitled "An improvement in Rolling Stock for Break of Gauge Railways and Tramways," which is more particularly described in the specification and the sheet of drawings which are hereunto annexed; and that he, the said Petitioner, hath deposited with the Honorable the Treasurer of the said Colony of New South Wales the sum of Twenty Pounds sterling, for defraying the expense of granting these Letters of Registration, as required by the Act of Council, sixteenth Victoria number twenty-four; and hath humbly prayed that I would be pleased to grant Letters of Registration, whereby the exclusive enjoyment and advantage of the said invention or improvement might be secured to him for a period of fourteen years: And I, being willing to give encouragement to all inventions and improvements in the arts or manufactures which may be for the public good, and having received a report favourable to the prayer of the said Petition from competent persons appointed by me to examine and consider the matters stated therein and to report thereon for my information, am pleased, with the advice of the Executive Council, and in exercise of the power and authority given to me by the said Act of Council, to grant, and do by these Letters of Registration grant unto the said John William Hall Hullett, his executors, administrators, and assigns, the exclusive enjoyment and advantage of the said invention or improvement, for and during the term of fourteen years from the date hereof; to have, hold, and exercise unto the said John William Hall Hullett, his executors, administrators, and assigns, the exclusive enjoyment and advantage thereof, for and during and unto the full end and term of fourteen years from the date of these presents next and immediately ensuing, and fully to be complete and ended: Provided always, that if the said John William Hall Hullett shall not, within three days after the granting of these Letters of Registration, register the same in the proper office in the Supreme Court, at Sydney, in the said Colony of New South Wales, then these Letters of Registration, and all advantages whatsoever hereby granted, shall cease and become void.

In witness whereof, I have hereunto set my sign manual, and have caused the present Letters of Registration to be sealed with the seal of the said Colony of New South Wales, at Government House, Sydney, in New South Wales, this twentieth day of September, in the year of our Lord one thousand eight hundred and eight-three.

[L.S.]

AUGUSTUS LOFTUS.

*Improvement in Rolling Stock for Break of Gauge Railways and Tramways.*

SPECIFICATION of John William Hall Hullett, of Port Augusta, in the Province of South Australia, engineer, for an invention entitled "An improvement in Rolling Stock for Break of Gauge Railways and Tramways."

My invention consists of an improvement in the manner of constructing railway and tramway rolling stock, by which the inconvenience, expense, and delay, caused by breaks of gauge on railway lines is prevented. This object is attained by an arrangement of the wheels upon the axles, by which the rolling stock automatically adapts itself from one gauge of rails to another, and different gauge. By my invention, rolling stock can travel on different gauges of rails without the intervention of manual, mechanical, or other power.

I fix wheels four or more in number, according to the number of different gauge lines over which the stock may have to pass, at distances corresponding with the gauges to be travelled over, and immediately a break of gauge occurs, the wheels adapted to such gauge come into operation. The boss of the inner wheel is made about an eighth of an inch larger in diameter than that of the outer wheel, and the axle is made to suit. The object may be better attained in some instances, where the narrow width of difference between the gauges will not allow of duplicating the wheels by making one or both wheels with an inner and outer flange, and in others by making each wheel separate.

Figures 1 and 2 of the drawing, show respectively both these methods; figure 3 is a plan of permanent way, showing how the difficulty of travelling over crossings is effectually met. The notches, *a*, cut in the rails, allow the wheels which are not in use to pass readily, whilst the guards, *b*, which are placed against the rails opposite to the notches protect the ordinary traffic from the risk of accident by going off the line at that point. By making the ends of the axle from the inside of the inner wheel to the outer extremity of a larger diameter than the other part, I provide for the increased strain which may be thrown on to that portion of the truck when a loaded waggon passes from a broad to a narrower gauge. I wish it to be distinctly understood that I do not confine myself to the use of only four wheels on each axle, but claim to add to such axles as many pairs of wheels as there may be different gauges of lines to be travelled over, and also of making one or more wheels with double flanges.

## CLAIM.

What I claim as my invention is the method of constructing railway and tramway rolling stock, so that such rolling stock is automatically adapted to different gauges of rails substantially as described in my specification, and shown in the drawing.

In witness whereof, I, the said John William Hall Hullett, have hereto set my hand and seal  
this                      day of                      , in the year of our Lord one thousand eight hundred  
and

Witness—

FRED. WALSH,  
Manager, Edwd. Waters,  
Patent Office, Sydney.

JNO. WM. HALL HULLETT,  
By his duly authorised Attorney,  
JNO. FAIRFAX CONIGRAVE.

This is the specification referred to in the annexed Letters of Registration granted to John William Hall Hullett, this twentieth day of September, A.D. 1883.

AUGUSTUS LOFTUS.

## REPORT.

Sir,

Sydney, 14 May, 1883.

Replying to your B.C. memo. of 1st instant, covering a Petition from Mr. J. W. H. Hullett, of Port Augusta, South Australia, for Letters of Registration for an invention entitled "An improvement in Rolling Stock for Break of Gauge Railways and Tramways," we have the honor to inform you that having examined the models and specification accompanying the Petition we recommend that Letters of Registration be granted to the Petitioner for the invention in question, as shown in the models and described in the specification above-mentioned.

All papers, &c., are returned herewith.

We have, &amp;c.

JOHN WHITTON.  
E. O. MORIARTY.

The Under Secretary of Justice.

[Drawings—one sheet.]

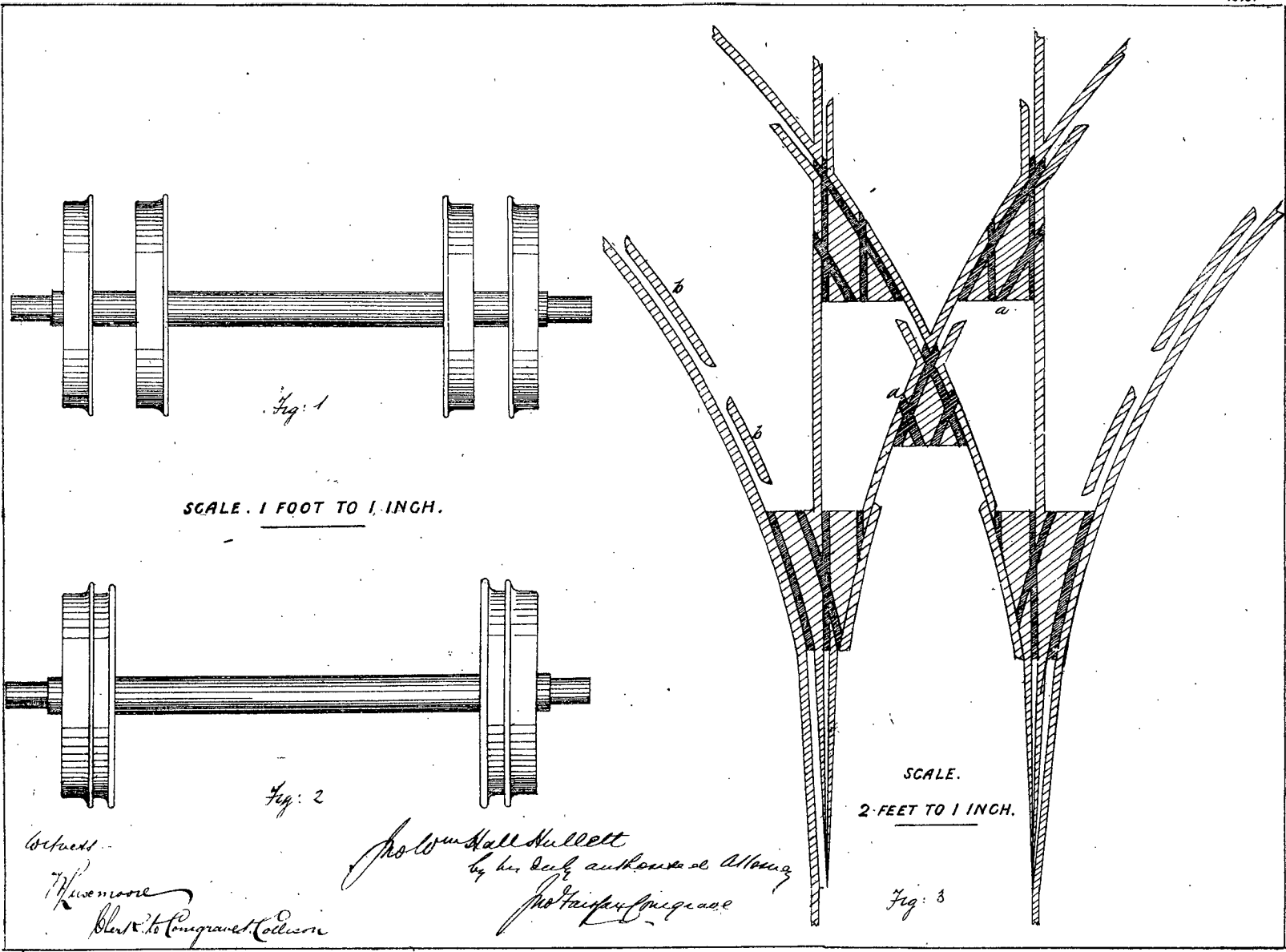


Fig: 1

SCALE. 1 FOOT TO 1 INCH.

Fig: 2

SCALE. 2 FEET TO 1 INCH.

Fig: 3

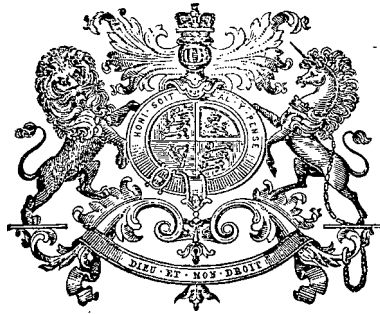
Wm. Moore  
 Clerk to Comptrol. Collins

John William Hall Bullett  
 by his duly authorized Attorney  
 John Fairbank

(Fig. 33.)

This is the Sheet of Drawings referred to in the annexed Letters of Registration granted to John William Hall Bullett, this 20<sup>th</sup> day of September A. D. 1883.

Augustus Loftus.



A.D. 1883, 4th October. No. 1314.

IMPROVED EXCAVATING MACHINE AND DREDGE.

LETTERS OF REGISTRATION to Thomas Lunham Baker, for an Improved Excavating Machine and Dredge.

[Registered on the 5th day of October, 1883, in pursuance of the Act 16 Vic. No. 24.]

BY HIS EXCELLENCY the RIGHT HONORABLE SIR AUGUSTUS WILLIAM FREDERICK SPENCER LOFTUS (commonly called LORD AUGUSTUS LOFTUS), Knight Grand Cross of the Most Honorable Order of the Bath, a Member of Her Majesty's Most Honorable Privy Council, Governor and Commander-in-Chief of the Colony of New South Wales and its Dependencies.

TO ALL TO WHOM THESE PRESENTS SHALL COME, greeting :

WHEREAS THOMAS LUNHAM BAKER, of Silver Hills, St. Peter's, Cook's River, in the Colony of New South Wales, hath by his Petition humbly represented to me that he is the author or designer of a certain invention or improvement in manufactures, that is to say, of an invention entitled "Improved Excavating Machine and Dredge," which is more particularly described in the specification and the sheet of drawings which are hereunto annexed; and that he, the said Petitioner, hath deposited with the Honorable the Treasurer of the said Colony of New South Wales the sum of Twenty Pounds sterling, for defraying the expense of granting these Letters of Registration, as required by the Act of Council, sixteenth Victoria, number twenty-four; and hath humbly prayed that I would be pleased to grant Letters of Registration, whereby the exclusive enjoyment and advantage of the said invention or improvement might be secured to him for a period of fourteen years: And I, being willing to give encouragement to all inventions and improvements in the arts or manufactures which may be for the public good, and having received a report favourable to the prayer of the said Petition from competent persons appointed by me to examine and consider the matters stated therein and to report thereon for my information, am pleased, with the advice of the Executive Council, and in exercise of the power and authority given to me by the said Act of Council, to grant, and do by these Letters of Registration grant unto the said Thomas Lunham Baker, his executors, administrators, and assigns, the exclusive enjoyment and advantage of the said invention or improvement, for and during the term of fourteen years from the date hereof; to have, hold, and exercise unto the said Thomas Lunham Baker, his executors, administrators, and assigns, the exclusive enjoyment and advantage thereof, for and during and unto the full end and term of fourteen years from the date of these presents next and immediately ensuing, and fully to be complete and ended: Provided always, that if the said Thomas Lunham Baker shall not, within three days after the granting of these Letters of Registration, register the same in the proper office in the Supreme Court, at Sydney, in the said Colony of New South Wales, then these Letters of Registration, and all advantages whatsoever hereby granted, shall cease and become void.

In witness whereof, I have hereunto set my sign manual, and have caused the present letters of Registration to be sealed with the seal of the said Colony of New South Wales, at Government House, Sydney, in New South Wales, this fourth day of October, in the year of our Lord one thousand eight hundred and eighty-three.

[L.S.]

AUGUSTUS LOFTUS.

*Improved Excavating Machine and Dredge.*

SPECIFICATION of THOMAS LUNHAM BAKER, of St. Peter's, Cook's River, in the Colony of New South Wales, for an invention entitled, "Improved Excavating Machine and Dredge."

THIS invention is mainly intended by me for use in agricultural work, such as dam-making, but I claim for it also its suitability to other excavating work, such as the removal of silt, mud, sandbanks, and similar deposits, or earth that has been ploughed up or otherwise made loose and easily removable, and I also claim for the machine its suitability for street-cleaning purposes.

This machine consists of a scoop (of a new form of construction, as will be hereinafter described) hung on pivots or centres, placed in slotted guys or ways, which are pendent from and secured to, and forming part of the top framing of the wheel carriage, as is clearly shown in figures 1, 2, and 3 in the accompanying drawing. The wheel carriage is also of novel construction to suit the requirements of this invention, and in addition to affording the necessary supports to and bearings for the axles of the carriage wheels to revolve in, it supplies a bed-plate and fulcrum for the axle-bar B, grooved wheels W W<sup>1</sup>, and supports R R and lever-bar L (figures 1, 2, 3) to operate upon, and which appliances are used in connection with the lowering and raising of the scoop, and also in lowering and raising automatically the front of the scoop when filled, or when scoop is about to be emptied of its contents.

This machine can be drawn by either oxen or horses, yoked or harnessed in the usual manner to the pole P (figures 1, 2), and to the swingle-bars. The driver, or an attendant assistant if preferred, is to be on foot, and to walk at the rear of the machine, between the pair of driving or guiding bars, G G<sup>1</sup> (figure 1). These guiding bars are also an essential feature of this invention, and will be more fully described hereafter. The reins (supposing that the driver be unaccompanied in charge of the machine) are passed from the bits, &c., over the top of the bed-plate above alluded to, and down to the driver's hands, as he stands ready to start the machine to its work.

When in readiness to commence work, the following are the positions in which the various portions of this machine should be, viz., the long arm of the lever-handle L should be at its angle of repose (as shown by the hard lines in figure 1), and when the lever is in this position the front of the scoop will be raised automatically by the short arm of the lever being depressed, and thereby putting into operation the parallel motion M (figures 1 and 6). The driver then takes one of the guiding bars G G<sup>1</sup> in each hand, and by bringing the handles nearly together he causes the bars to grip into the notched catches which are affixed to the back of the scoop C C (figures 1, 2, 3, 5). Supposing the machine to be now at the place of operations, or at the site of the material to be excavated, the driver elevates the handles of the bars G G<sup>1</sup> until the cutting or front edge of the scoop is depressed sufficiently to commence its work. The oxen or horses being urged forward, the scoop is dragged along and fills itself. When filled, the front of the scoop is lowered into its place by the driver, by means of depressing the lever-bar L, and the scoop and its contents are thereby also automatically raised a few inches above the surface of the ground. The machine is then driven to the desired place for depositing the contents of the scoop. The front of the scoop is then lifted as before described, the guiding bars are raised so as to cause the scoop to tilt forward until its cutting edge touches the ground, the cattle or horses are urged forward, and the scoop is thus forced to revolve on its axis (by rising in the slotted guys as shown on figure 4), and it thereby empties itself and immediately afterwards returns into position for refilling. It is also to be noted that in consequence of the peculiar construction of the scoop in this invention, when the handles of the guiding bars G G are brought together, as before described, the bottom of the scoop, working on its centre T (figure 5), spreads out fanshape at its cutting edge, and thus clears a track for the wheels of the machine.

The following are the details of the various parts of this machine, viz. :—

1. The Scoop (figures 1, 2, 3, 4, 5).—This is of galvanized or other sheet-iron, of such gauge as the nature of the work upon which it is to be employed may require. It is constructed in three pieces, viz., the sides, back, and bottom in two pieces (connected by and working on the centre pin T, figure 5), and the front or sliding piece to enclose contents of scoop when full. The dimensions of the scoop are such as to enable the scoop to contain about one cubic yard of material. The bottom and back portions of the scoop are overlapping, and the back portions are of the curved form shown on figures 2 and 5, to facilitate their passing each other freely when scoop is spread out or closed in. The front of the scoop runs between guys provided for the purpose, and is secured to the framing of the carriage as shown on figures 1 and 2. An iron handle or rod (working on hinges or centres at top and bottom) is secured to the front of the scoop, and it is connected near the top with a parallel motion, M, attached to the short arm of the lever L. The guys or ways in which the pivots or axles of the scoop run are protected by metal boxes. The back of the scoop is fitted with strong iron or wood catches (for the guiding bars G G<sup>1</sup> to lock into), as shown on figure 4.

2. The Lever-bar L (figures 1, 2, 3).—This lever-bar has a short and a long arm, and works on the fulcrum afforded by the axle-bar B and wheels W W<sup>1</sup> (revolving in the supports R R), firmly attached to the top framing of the carriage. The short arm of the lever is birdsmouthed, or cut to receive the centre pin, &c., upon which an ordinary parallel motion M (which is also attached to the lifting rod or handle of front of scoop) is to work; the parallel motion M is of metal preferably. The grooved wheels W W<sup>1</sup> are secured to the axle-bar B so as to revolve with it in the supports R R<sup>1</sup>. One end of each of the lifting chains (or wire or hempen ropes) R<sup>1</sup> R<sup>2</sup> is securely fixed to the bottom of each of the grooved wheels W W<sup>1</sup>, and the other ends of these chains or ropes are then passed over the wheels W W<sup>1</sup>, and down to and round the axles or pivots of the scoop, and are then brought up and securely fixed to the top framing of the carriage (as shown on figures 1 and 4), thus forming a down haul for elevating or depressing the scoop by the action of the lever L, which is made either of wood or iron, preferably of American ash or Colonial or other hardwood, and securely fixed to the axle-bar B at its centre. The axle-bar, grooved wheels, and supports are all of metal.

3. Guiding-bars G G (figures 1, 2, 3).—These are of American, Colonial, or other hardwood, and of the form shown on drawing as nearly as may suit the work to be done by the machine; they are supported near one end by the axles or pivots of the scoop (which are extended for that purpose through the guys as shown), and fixed to such axles by linch-pins or otherwise.

4. Parallel Link-motion M and M<sup>1</sup> (figures 1 and 6).—This is an ordinary parallel link-motion of metal; but I claim that the parts thereof are of novel design, to suit the requirements of this invention, and



*Improved Excavating Machine and Dredge.*

and for the purpose of obtaining the automatic raising and lowering of the front of the scoop simultaneously with the lowering and raising respectively of the scoop itself (by means of the lever-handle L as before described). I use a second fulcrum of iron or other metal securely attached to the bed-plate. The vertical lifting rod is attached to the front of the scoop by a hinge or pin-motion at top and bottom; the upper portion or head of the lifting rod is made with forged cheeks to receive the end of the second link of the parallel motion M, and this works on a pin centre in such cheeks. This second link is also forged with cheeks to receive the first link of the motion, and is connected therewith by a pin centre. The second link is secured to and works on the pin centre of the second fulcrum, secured to the bed-plate as before described; the first link is also attached to the short arm of the lever L by a pin centre. These link-motions have inclined planes in the line of their action, to give fullest play thereto.

5. Swivel Balance Catch Hook H (figures 1, 2, 3).—A balance hook of wrought iron and of form shown on drawing is supported in its position on a pivot (on which it hangs freely), running into and through and secured to a forging made upon the wrought-iron rod F, which is fixed to the carriage at each side of and above the scoop, as shown. By these means the hook is brought into such position as enables it to retain the lever L in position when it is depressed (as shown by dotted lines in figure 1, and also in full lines in figure 3).

The remainder of the forecarriage of this machine, viz., the draw-bar, pole, wheels, &c., are not claimed by me as original in construction; but the wheels are of such diameter as to admit of the scoop revolving freely upon its axis and axles, which are supported as shown by bearers suspended from the bed-plate. The wheels of the machine are also supported by the bed-plate, as shown. The framing of carriage to be preferably of American, Colonial, or other hardwood.

R. P. ABBOTT,  
Agent for T. L. BAKER.

This is the specification referred to in the annexed Letters of Registration granted to Thomas Lunham Baker, this fourth day of October, A.D. 1883.

AUGUSTUS LOFTUS.

## REPORT.

Sir,

Sydney, 7 July, 1883.

In reply to your B.C. minute of the 22nd ultimo, requesting report on Petition for Letters of Registration for an invention entitled "Improved Excavating Machine and Dredge," the applicant being Mr. T. L. Baker, we have to report that as there are no definite claims made we recommend issue of Letters protecting the combination, which is novel, though the details are necessarily common or similar to some of the many excavators already patented.

If applicant claims protection for any specific detail, and sets forth same, we will then be able to report more definitely.

We have, &c.,

JAMES BARNET.  
WILLIAM C. BENNETT.

The Under Secretary of Justice.

Sydney, 14 August, 1883.

MEMO.—We are of opinion that Letters might now be issued in accordance with our Report of 7th July herewith.

The Under Secretary of Justice.

J.B.  
W.C.B.

[Drawings—one sheet.]

# BAKERS IMPROVED EXCAVATING MACHINE AND DREDGE.

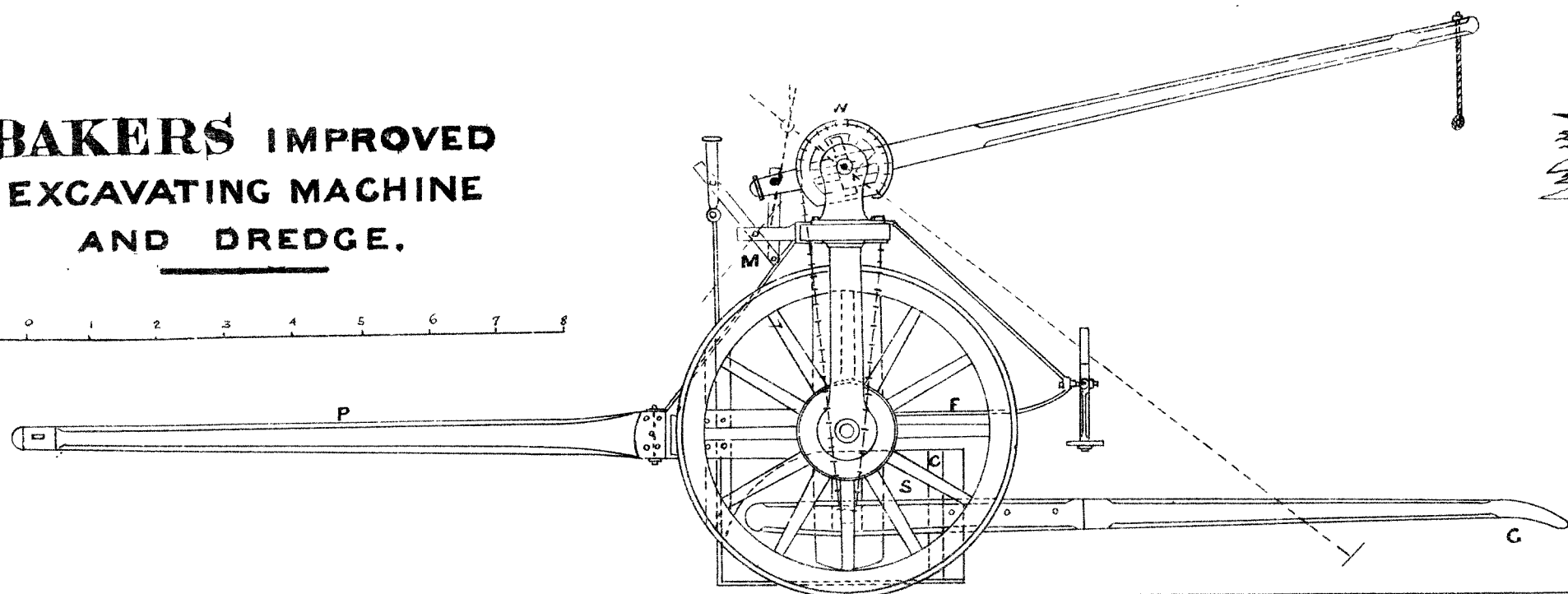


Fig: 1.

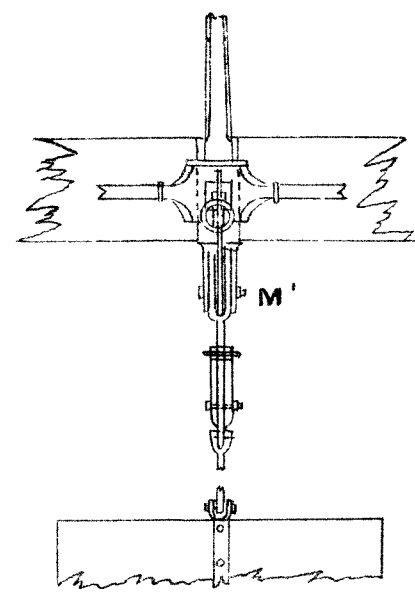


Fig: 6.

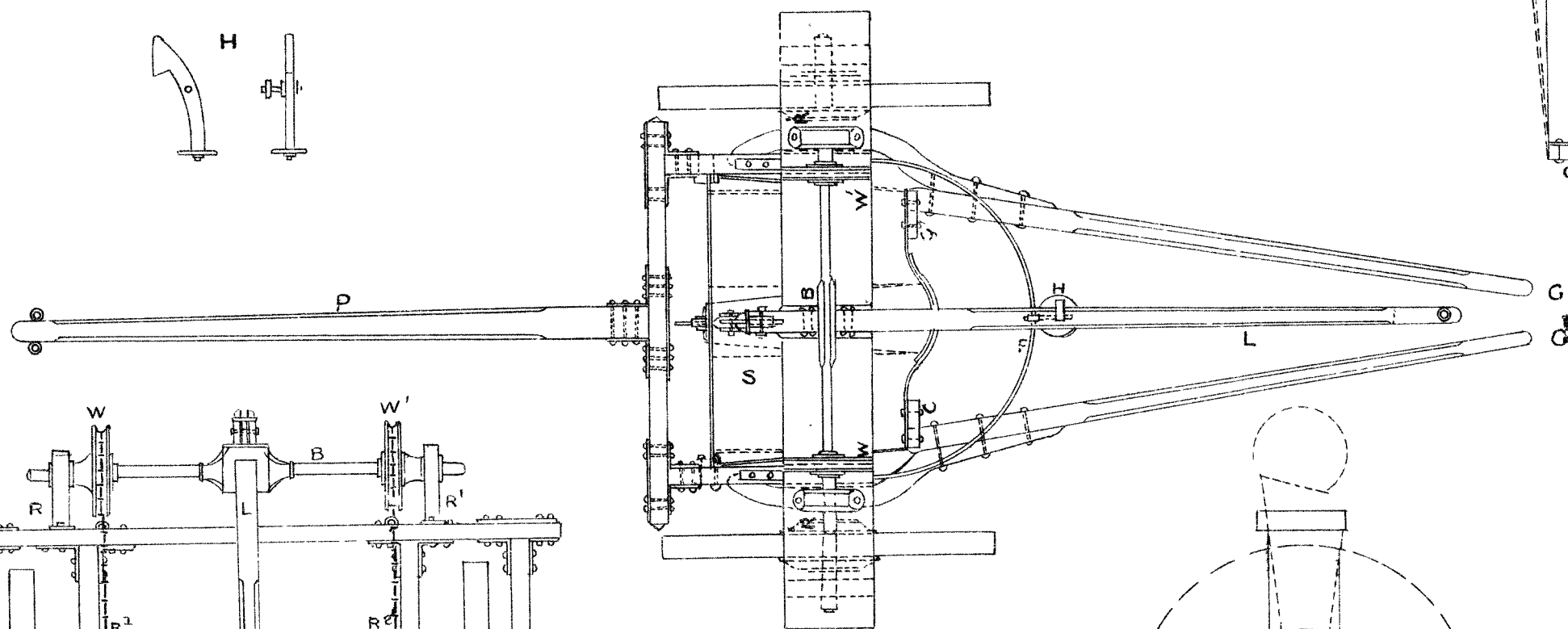
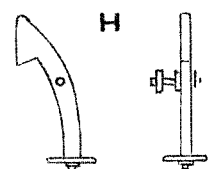


Fig: 2.

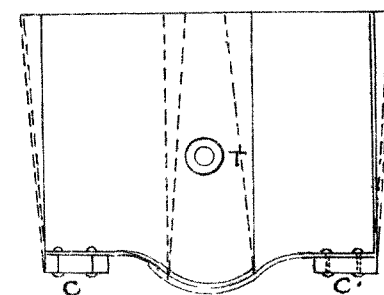


Fig: 5.

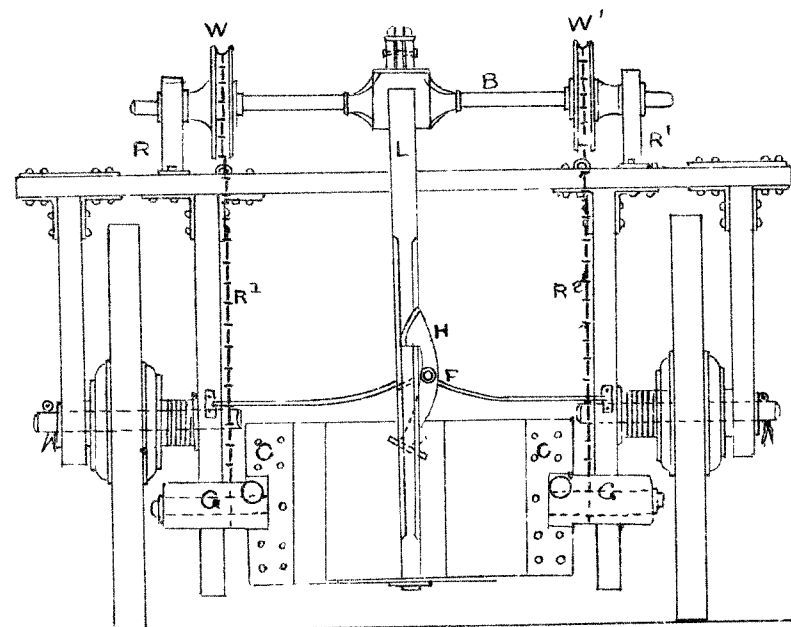


Fig: 3.

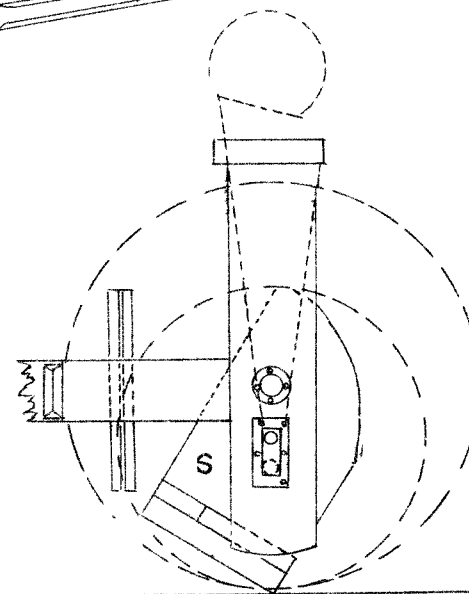


Fig: 4.

*This is the Sheet of Drawings referred to in the annexed  
Letters of Registration granted to Thomas Ingham Baker,  
this fourth day of October, A.D. 1883.*

*Augustus Loftus.*

PHOTO-LITHOGRAPHED AT THE GOVT. PRINTING OFFICE,  
SYDNEY, NEW SOUTH WALES.

(Sig 35.)



A.D. 1883, 4th October. No. 1315.

IMPROVEMENTS IN STEAM BOILERS AND FURNACES.

LETTERS OF REGISTRATION to Adam Cyrus Engert, for Improvements in Steam Boilers and Furnaces.

[Registered on the 6th day of October, 1883, in pursuance of the Act 16 Vic. No. 24.]

BY HIS EXCELLENCY THE RIGHT HONORABLE SIR AUGUSTUS WILLIAM FREDERICK SPENCER LOFTUS (commonly called LORD AUGUSTUS LOFTUS), Knight Grand Cross of the Most Honorable Order of the Bath, a Member of Her Majesty's Most Honorable Privy Council, Governor and Commander-in-Chief of the Colony of New South Wales and its Dependencies.

TO ALL TO WHOM THESE PRESENTS SHALL COME, greeting:

WHEREAS ADAM CYRUS ENGERT, of Three Mills-lane, Bromley-by-Bow, in the county of Middlesex, England, hath by his Petition humbly represented to me that he is the author or designer of a certain invention or improvement in manufactures, that is to say, of an invention entitled "Improvements in Steam Boilers and Furnaces," which is more particularly described in the specification and the sheet of drawings which are hereunto annexed; and that he, the said Petitioner, hath deposited with the Honorable the Treasurer of the said Colony of New South Wales the sum of Twenty Pounds sterling, for defraying the expense of granting these Letters of Registration, as required by the Act of Council, sixteenth Victoria, number twenty-four; and hath humbly prayed that I would be pleased to grant Letters of Registration, whereby the exclusive enjoyment and advantage of the said invention or improvement might be secured to him for a period of fourteen years: And I, being willing to give encouragement to all inventions and improvements in the arts or manufactures which may be for the public good, and having received a report favourable to the prayer of the said Petition, from competent persons appointed by me to examine and consider the matters stated therein and to report thereon for my information, am pleased, with the advice of the Executive Council, and in exercise of the power and authority given to me by the said Act of Council, to grant, and do by these Letters of Registration grant unto the said Adam Cyrus Engert, his executors, administrators, and assigns, the exclusive enjoyment and advantage of the said invention or improvement, for and during the term of fourteen years from the date hereof; to have, hold, and exercise unto the said Adam Cyrus Engert, his executors, administrators, and assigns, the exclusive enjoyment and advantage thereof, for and during and unto the full end and term of fourteen years from the date of these presents next and immediately ensuing, and fully to be complete and ended: Provided always, that if the said Adam Cyrus Engert shall not, within three days after the granting of these Letters of Registration, register the same in the proper office in the Supreme Court, at Sydney, in the said Colony of New South Wales, then these Letters of Registration, and all advantages whatsoever hereby granted, shall cease and become void.

In witness whereof, I have hereunto set my sign manual, and have caused the present Letters of Registration to be sealed with the seal of the said Colony of New South Wales, at Government House, Sydney, in New South Wales, this fourth day of October, in the year of our Lord one thousand eight hundred and eighty-three.

[L.S.]

AUGUSTUS LOFTUS.

*Improvements in Steam Boilers and Furnaces.*

SPECIFICATION of ADAM CYRUS ENGERT, of Three Mills-lane, Bromley-by-Bow, in the county of Middlesex, England, for an invention entitled "Improvements in Steam Boilers and Furnaces."

HERETOFORE, in Cornish and other such like boilers with internal furnace flues the flues have usually been circular in cross-section, and of the same diameter from end to end, and the furnace has been contained within the front end of the flue.

According to my invention, I make the furnace flue as nearly as great a width as the width of the boiler will allow, and comparatively shallow in depth. At the front of the boiler I enlarge the height of the flue, making it bell-mouthed, to form the furnace chamber or fire-box, which may extend forwards to some distance in front of the boiler.

The fire bars or bed I make to slope downwards towards the front, and at the front I bend them upwards, or provide front bars to retain the fuel from dropping downwards off the front of the sloping bars. The front of the fire-box is closed in to the extent desired with a fixed box and with front fire-doors.

The ordinary ash-pit is practically done away with, as only sufficient space is left below the bars for the admission of air to the furnace, whilst the ashes falling through the bars fall, or can readily be withdrawn away, downwards along the sloping bottom of the flue, and drop down in front of the boiler.

In a Cornish boiler, I place the furnace flue about midway between the top and bottom of the boiler, and below the furnace flue I provide another flattened flue, passing horizontally through the boiler, to serve as a return flue.

In the setting of the boiler I connect the rear ends of these flues, so that the gases issuing from the rear end of the furnace flue may pass back through the lower flue to the front of the boiler. And similarly, in the setting of the boiler at the front, I either connect the front end of this lower flue to a third still lower flue passing through the boiler, or to a brickwork flue below its bottom.

The lower flue or flues of the boiler I make, like the furnace flue, of about as great a width as the width of the boiler will allow, and of comparatively small depth. The boiler flues may be stayed with tubular vertical stays.

In the case of boilers heated by external furnaces, the furnaces may be formed in the same way, with the bed sloping downwards towards the front, and with the flue from the fire-place of small depth and considerable width, as above described. The furnaces of bakers' ovens and other furnaces may also be formed in the same manner.

Figure 1 of the drawings hereunto annexed shows a cross-section; figure 2, a longitudinal section; and figure 3, a plan view in section; and figure 4, a front view of a Cornish boiler and its furnace, constructed according to my invention.

A is the furnace flue, B the return flue below it, and C a flue on the outside of the boiler leading to the chimney; D is the bell-mouthed end of the flue. A, the top of the flue, is, as shown, made horizontal, or nearly so, whilst the bottom of the flue is made to slope downwards. In front of this bell-mouthed end is secured a box, E, forming the front of the fire chamber; it is closed in at the front by doors, F, as shown at figures 2 and 4. Inside the door, and separated from it by short distance-pieces, is a perforated baffle plate, so that air entering through slots at the top and bottom of the door has to issue into the furnace through the holes in the baffle plate, and thereby gets evenly distributed and also heated as it passes to the fire. The bottom of the box E is open to allow air to pass to the fire between the fire-bars. Slides are applied to the slots in the door, so that more or less air can be allowed to enter through them; this allows of more air being admitted into the furnace after firing for the more complete combustion of the gases then driven off from the newly introduced fuel. One door only should be opened at a time when fresh fuel is put on; the heat from the other half of the fire is then so great that the incoming air will be sufficiently heated to cause it at once to enter into combustion with the gases it meets with.

G are the fire-bars; G<sup>1</sup> is a dead plate at the back end of the bars, or no dead plate might be used, and the bars made to extend the whole length. The bars G run lengthwise of the boiler and slope downwards towards the front; their front ends are bent upwards, as shown at figure 2, to retain the fuel and prevent its dropping off from the bars when the door is opened. The flues A and B are, as shown, stayed with numerous vertical tubular stays; these, as they stand across the flues, retard the passage of the heated gases from the fire, and the gases curl around and effectually heat them, and as they become heated they cause a brisk circulation of the water in the boiler and keep it in agitation, thereby preventing the accumulation of deposit on the tops of the flues or at the bottom of the boiler, as the circulation is so rapid that no accumulation of sediment, however heavy it may be, can possibly take place.

The two flues A and B occupy less space in the boiler than the two flues of an ordinary Lancashire boiler, and the crown of the top flue is not so high as the crowns of the ordinary flues, and there is therefore less risk of the water-level getting below the crown, and therefore there is less risk of danger from this cause.

I is a feed-water heater forming the top of the short flue which connects the back of the flue A with the back of the flue B. J is a water tank, from which the feed-water heater is supplied with water. K is an air and steam pipe from the feed-water heater; any water carried upwards through this pipe is, as shown, returned to the water-supply tank.

The bulk of the water in this feed-water heater can only be raised to 212° Fahrenheit; but in order more effectually to throw down any carbonate of lime or other such substances the water may hold in solution, it is desirable that the water should be still further heated before being fed into the boiler, so that there shall be nothing deposited from the water in the boiler itself. This I effect by placing in the feed-water heater a tube kept supplied with steam by a smaller pipe from the boiler, so that the water around the steam tube may be the more highly heated; and I draw off the feed-water from the boiler at a point near to where it is thus more highly heated.

Steam from the interior of the above-mentioned steam-heated tube may be led through another small pipe to the front of the boiler, and be distributed through several jets below the fire-bars, so that it may rise up between them and through the fire, and so be utilized for effecting the better combustion of the fuel, and reducing the draught otherwise required.

The sediment which accumulates at the bottom of the tank should be blown out frequently.

L is an iron casing at the front of the boiler, serving to connect the front of the flue B with the front entrance to the flue C.

The

*Improvements in Steam Boilers and Furnaces.*

The steam boilers of locomotive engines may advantageously be constructed in the manner hereinbefore described.

At figure 5 I have shown a longitudinal section and at figure 6 an end view of the furnace or fire-place of a bakers' oven constructed according to my invention.

The oven itself I arrange in the ordinary manner, so that the heated gases and flame from the furnace enter the oven and circulate around its interior before passing to the chimney.

A is the flue leading from the furnace to the oven. B is the ordinary ash-pit. Ordinarily, the fire-bars would be laid horizontally about at the level of the bottom of the flue A. I remove these bars and replace them by a dead plate, C, and bars, D, which slope downwards towards the front, as shown at figure 5. E are front bars to keep the fuel on the sloping bars D. The bars D and front bars E form the bottom and front of a fire-basket, which is supported, as shown, by bearers, F. G are plates rising up at the two sides of the fire-basket; they have hinged to them at their upper end a fire-door, H, which can be turned downwards, as shown at figure 5, when it is to be opened.

At the back of this door I also mount a baffle plate, so that air entering through a grating in the door is checked and heated before it passes to the fire.

When the fire is to be fed with fuel the fire is raked forwards and the fresh fuel thrown on to the dead plate at the back; it there becomes heated, and as the only air that can mingle with the gases given off from it must of necessity be highly heated, as it must either have passed through or over the bright fire at the front, the gases at once ignite, and a large body of flame passes from the furnace to the oven. The boiler furnace should be fed with fuel in the same way.

Other furnaces than the special forms of furnace hereinbefore mentioned might also be formed in the manner described, that is, with fire-bars sloping downwards towards the front, with the exit flue at a point above the top of the bars, so that the flames and heated gases arising from the front of the fire may the better sweep over the surface of the fuel at the back of the bars and promote its combustion.

Having thus described the nature of my invention and the manner of performing the same, I would have it understood that I claim—

First—The construction of steam boilers, with a furnace flue made bell-mouthed at the front to form the fire-place, substantially as hereinbefore described.

Second—The construction and setting of steam boilers, substantially as hereinbefore described and shown in the drawing annexed.

Third—The construction of the furnaces of bakers' ovens, substantially in the manner hereinbefore described, and shown in the drawing annexed.

Fourth—The construction of furnaces with the fire-bars sloping downwards towards the front, and with an exit flue at the back above the top of the fire-bars, substantially as described.

In witness whereof, I, the said Adam Cyrus Engert, have hereunto set my hand and seal, this thirteenth day of March, 1883.

A. C. ENGERT.

This is the specification referred to in the annexed Letters of Registration granted to Adam Cyrus Engert, this fourth day of October, A.D. 1883.

AUGUSTUS LOFTUS.

### REPORTS.

Sir,

We do ourselves the honor to report, in reply to your B.C. 83-5,550, of the 4th instant, that we are of opinion that the prayer of Mr. Adam Cyrus Engert for the registration of an invention entitled "Improvements in Steam Boilers and Furnaces," may be granted in terms of his drawings and specification with the exception of that portion of the claim which refers to "the flattened flues with vertical tubular stays," such flattened flues and vertical tubular stays not being novel.

We have, &c.,

E. O. MORIARTY.  
JOHN WHITTON.

The Under Secretary of Justice.

Sir,

We do ourselves the honor to report, in reply to your B.C. of the 15th June last, No. 83-7,338, that we are of opinion that the prayer of Mr. Adam Cyrus Engert for the registration of an invention entitled "Improvements in Steam Boilers and Furnaces," may be granted in terms of his drawing and amended specification, as suggested in our report of the 21st May last.

We have, &c.,

E. O. MORIARTY.  
JOHN WHITTON.

The Under Secretary of Justice.

Fig. 1.

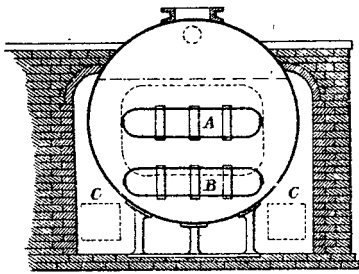


Fig. 2.

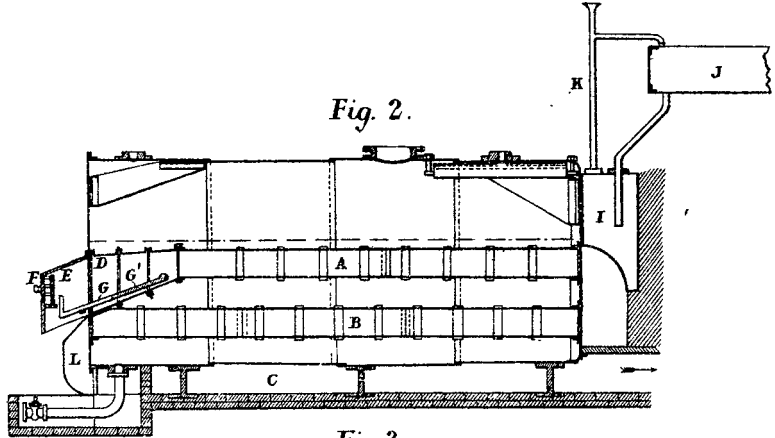


Fig. 4.

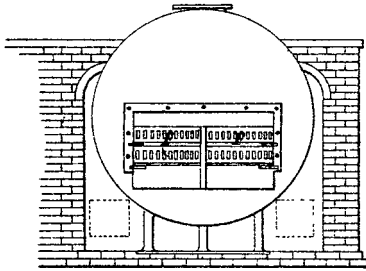


Fig. 3.

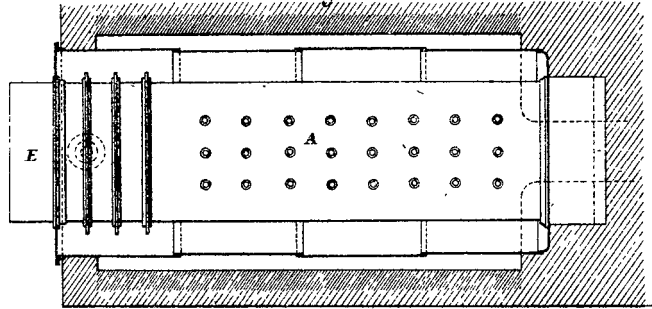


Fig. 5.

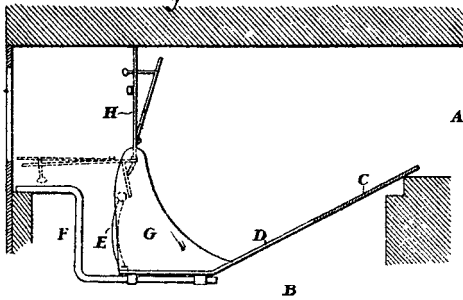


Fig. 6.

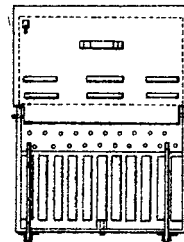


Fig. 35.

*This is the Sheet of Drawings referred to in the annexed Letters of Registration granted to Adam Cyrus Engert, this fourth day of October A. D. 1883.*

*Augustus Loftus.*



A.D. 1883, 4th October. No. 1316.

IMPROVEMENTS IN THE TREATMENT OF INDIARUBBER, GUTTAPERCHA, &c.

LETTERS OF REGISTRATION to Henry Gerner, for Improvements in the Treatment of Indiarubber, Guttapercha, and Analogous Gums.

[Registered on the 6th day of October, 1883, in pursuance of the Act 16 Vic. No. 24.]

BY HIS EXCELLENCY THE RIGHT HONORABLE SIR AUGUSTUS WILLIAM FREDERICK SPENCER LOFTUS (commonly called LORD AUGUSTUS LOFTUS), Knight Grand Cross of the Most Honorable Order of the Bath, a Member of Her Majesty's Most Honorable Privy Council, Governor and Commander-in-Chief of the Colony of New South Wales and its Dependencies.

TO ALL TO WHOM THESE PRESENTS SHALL COME, greeting:

WHEREAS HENRY GERNER, of 67, Strand, in the City of Westminster, London, England, hath by his Petition humbly represented to me that he is the author or designer of a certain invention or improvement in manufactures, that is to say, of an invention entitled "Improvements in the Treatment of Indiarubber; Guttapercha, and Analogous Gums," which is more particularly described in the specification which is hereunto annexed; and that he, the said Petitioner, hath deposited with the Honorable the Treasurer of the said Colony of New South Wales the sum of Twenty Pounds sterling, for defraying the expense of granting these Letters of Registration, as required by the Act of Council, sixteenth Victoria, number twenty-four, and hath humbly prayed that I would be pleased to grant Letters of Registration whereby the exclusive enjoyment and advantage of the said invention or improvement might be secured to him for a period of fourteen years: And I, being willing to give encouragement to all inventions and improvements in the arts or manufactures which may be for the public good, and having received a report favourable to the prayer of the said Petition from competent persons appointed by me to examine and consider the matters stated therein and to report thereon for my information, am pleased, with the advice of the Executive Council, and in exercise of the power and authority given to me by the said Act of Council, to grant, and do by these Letters of Registration grant unto the said Henry Gerner, his executors, administrators, and assigns, the exclusive enjoyment and advantage of the said invention or improvement, for and during the term of fourteen years from the date hereof; to have, hold, and exercise unto the said Henry Gerner, his executors, administrators, and assigns, the exclusive enjoyment and advantage thereof, for and during and unto the full end and term of fourteen years from the date of these presents next and immediately ensuing, and fully to be complete and ended: Provided always, that if the said Henry Gerner shall not, within three days after the granting of these Letters of Registration, register the same in the proper office in the Supreme Court; at Sydney, in the said Colony of New South Wales, then these Letters of Registration, and all advantages whatsoever hereby granted, shall cease and become void.

In witness whereof, I have hereunto set my sign manual, and have caused the present Letters of Registration to be sealed with the seal of the said Colony of New South Wales, at Government House, Sydney, in New South Wales, this fourth day of October, in the year of our Lord one thousand eight hundred and eighty-three.

[L.S.]

AUGUSTUS LOFTUS.

*Improvements in the treatment of Indiarubber, Guttapercha, &c.*

SPECIFICATION of HENRY GERNER, of 67, Strand, London, in England, for an invention entitled "Improvements in the treatment of Indiarubber, Guttapercha, and Analogous Gums."

THIS process relates to the manufacture of products consisting of oilless and huskless seed farinas, and of other ingredients having the same or nearly the same specific gravity as rubber, in contradistinction to the heavily-weighted products resulting from the metallic substances introduced by rubber manufacturers generally. I also claim, as a part and feature of the present process, the manufacture of products consisting of rubber, sulphur, and the said pure farinas, but chiefly in combination with gum kauri, with which, together with camphor, excellent results are achieved.

The introduction of gum kauri into my mixture is the great feature of the process. Apart from the fact that this gum has already been introduced, although not successfully, into rubber mixtures by others, I have attained no permanent success with it unless in combination with camphor; and I therefore have no desire to claim it unless in combination with that gum, together with rubber and sulphur, or with rubber, sulphur, and the said pure farinas.

Hereinbefore and hereinafter, the use of the term *rubber* replaces and implies "indiarubber, guttapercha, or an analogous gum"; the use of the term *camphor* replaces and implies "camphor or its chemical equivalents"; the use of the term *sulphur* replaces and implies "sulphur or its chemical equivalents"; the use of the term *kauri* replaces and implies "gum kauri or an analogous resinous gum"; the use of the term *mustard* replaces and implies "the farina of mustard seed, or of poppy seed, linseed, &c., carefully separated from their oils and husks"; the use of the term *gasoline* replaces and implies "gasoline, benzine, or an analogous hydro-carbon"; the use of the term *hard rubber* will replace and imply "ordinarily vulcanized hard indiarubber, or vulcanite, or ebonite"; and the use of the term *soft rubber* will replace and imply "ordinarily vulcanized soft indiarubber."

I have found in practice that, as far as the action of the camphor upon the kauri is concerned, a quarter of a pound of camphor to every pound of kauri is very recommendable, and as little as one-eighth of a pound of the former to every pound of the latter is generally all that is required. In fact, all that is needed is camphor enough to thoroughly penetrate and dissolve the kauri with the aid of heat. Kauri being so much cheaper than camphor, and capable of being kept for any length of time, unlike camphor, without evaporation and loss, manufacturers will not use any more camphor than is necessary.

The proper manipulation of the camphor and kauri for use in rubber manufacture is as follows:—

For use in hard goods, pulverize the camphor and the kauri separately on common grinding, reducing, and mixing rollers, which for this purpose must not be heated. Break the large lumps to nut size first so as not to injure the rollers, and let these fragments go through the rollers a couple of times. Then add to this so much dry flowers of sulphur, free from acid, as is required for the particular product to be manufactured. If one pound of sulphur is mixed with one pound of mixed camphor and kauri, and this in turn mixed with one pound of rubber, the proportion will be right for many classes of hard goods, which thus contain one-half of a pound of sulphur to each pound of rubber, camphor, and kauri together. The mixture before the introduction of the rubber must be thorough, and again go through the rollers several times, screwing the rollers up by degrees nearer to each other as the mixture becomes finer. It is then ground in a proper mill, and taken through a suitable sieve, having meshes which will make what goes through as fine as the flowers of sulphur were before mixing. What will not go through must be reground on the mill until it all goes through the sieve.

By a proper use of gasoline, which serves to moisten the mixture in the mill, on the rollers, and in the sieves to prevent clogging, both time and power are saved. The mixture so prepared, when destined for hard goods, will keep almost any length of time without hardening, and can therefore be conveniently kept on hand for use. All that is needed is to resift the mixture before use, moistened with gasoline, the latter being also mixed into it before bringing it on the hot rollers, so as to insure not only the prevention of clogging on the rollers, but also the very necessary fine subdivision of every particle of the mixture, in default of which the result will not be satisfactory. Any lumps in the mixture and in the quantity mixed on the rollers by the operator will appear in the vulcanized product.

As the camphor and kauri require the same amount of sulphur for their proper vulcanization as the rubber, the same quantity of sulphur per pound of camphor and kauri should be used as per pound of rubber.

How much camphor and kauri should be employed in the mixture for hard as well as for soft goods depends entirely upon the grades and nature of goods required, and for what purpose they are to be used. For certain grades of hard goods, half a pound of mixed camphor and kauri to every pound of rubber may be used to great advantage; while for other grades, a quarter of a pound, or an eighth of a pound, or even less, will prove to be the best proportion.

For use in soft goods, the mixture of camphor, kauri, and sulphur, and its manipulation, is substantially the same as hereinbefore indicated for use in hard goods, with the difference that the mixture requires much less sulphur. Of this mixture no more ought to be made than is used for the day, as it gets hard and lumpy in time. This can, however, be prevented by moistening the mixture daily with gasoline. Under all circumstances, the mixture should be resifted and so moistened before being brought on the rollers and there incorporated with rubber.

I desire especially to point out the necessity of the proper use of a light hydro-carbon with which to moisten the mixture sufficiently both for hard and soft goods. In default hereof, the mixture will stick to the rollers, and then no thorough incorporation can take place; lumps will be formed, and the product will be spoiled.

The same amount of sulphur per pound of rubber which is required for making soft goods is also required per pound of camphor and kauri employed in the mixture. Thus, if one ounce of sulphur is employed, as is usual for soft goods, for every pound of rubber, one ounce of sulphur must also be employed for every pound of camphor and kauri used in the mixture.

When a pound of finely powdered mustard is added to four pounds of the mixture of rubber, camphor, kauri, and sulphur, in their proper proportions, as hereinbefore indicated, a very superior compound



*Improvements in the treatment of Indiarubber, Guttapercha, &c.*

compound for certain soft goods is obtained. I do not, however, restrict myself to this proportion. I also use mustard in hard-goods mixtures. These mixtures require less moistening with gasoline than the mixture without it, as it is less liable to stick to the rollers.

With regard to the proper temperature and time for vulcanization of hard-goods mixtures, great care should be taken to raise the temperature very gradually; but a shorter time, by employing a higher temperature, will suffice than is required for hard-rubber vulcanization. Four to five hours are all that is required, according to the thickness of the goods, while for hard rubber as much as thirteen hours are required. The temperature should, for the last two hours, be raised as high as up to 312° F., and even up to 320° F., while for hard rubber the utmost is generally 300° F. For the vulcanization of the soft-goods mixtures embodying my invention, it is safe to employ the same time as for the vulcanization of soft rubber, but as a rule less time will suffice. The temperature should be raised at least to 280° F., and in many cases even up to 312° F. and 320° F., the latter temperature being approached as kauri and camphor predominate in the mixtures.

All the mixtures herein described can be worked on the rollers, calenders, and on rubber machinery in general, at a much lower temperature than common rubber mixtures, a great desideratum, since the higher temperature employed for the latter destroys the fibres of the rubber. This lower temperature varies with the nature of the mixture, so that the experienced operator will understand that it cannot be stated here within reasonable limits.

It will be readily understood that I do not restrict myself to any of the proportions of mixtures, or to any of the periods or temperatures hereinbefore given. The purpose for which certain goods, both hard and soft, are destined, requiring certain qualities, must of necessity entirely guide the experienced manufacturer in his choice of proportions, manipulations, and circumstances.

What I claim as new is,—

1. The use and treatment of camphor, or its chemical equivalent, in combination with indiarubber, guttapercha, or an analogous gum, and with sulphur, or its chemical equivalent, substantially as set forth.
2. In general, the use, treatment, and incorporation into mixture of indiarubber, guttapercha, or an analogous gum, of the finely powdered farinas of mustard seed, and of poppy seed, linseed, &c., carefully separated from their oils and husks, substantially as set forth.
3. The use and treatment of the mixture specified in the first claim, together with the farinas specified in the second claim, but in which the flours of the said seeds, with the whole or a part of their oils still contained in them, and not merely their farinas as in the present process, were employed, substantially as set forth.
4. The use and treatment of gum kauri, or an analogous resinous gum, in combination with camphor or its chemical equivalent, and with sulphur or its chemical equivalent, in all processes of rubber and analogous manufactures, substantially as set forth.
5. The use and treatment of the mixture specified in the fourth claim, together with the farinas specified in the second claim, substantially as set forth.
6. As new articles of manufacture, vulcanized products consisting of the ingredients as severally specified in the foregoing first, third, fourth, and fifth claims, substantially as set forth.

In witness whereof, I, the said Henry Gerner, have hereto set my hand and seal, this        day  
of December, 1882.

Witness—

H. J. HADDAN,  
67, Strand, London.

HENRY GERNER.

This is the specification referred to in the annexed Letters of Registration granted to Henry Gerner, this fourth day of October, A.D. 1883.

AUGUSTUS LOFTUS.

## REPORT.

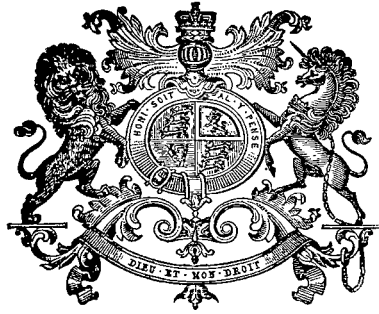
Sir,

The application of Mr. Henry Gerner for Letters of Registration for "Improvements in the treatment of Indiarubber, Guttapercha, and Analogous Gums," having been referred to us, we have examined the specification accompanying the same, and have now the honor to report that we see no objection to the issue of Letters of Registration as prayed for.

Sydney, 18 August, 1883.

We have, &c.,  
J. SMITH.  
CHAS. WATT.

The Under Secretary of Justice.



A.D. 1883, 4th October. No. 1317.

IMPROVEMENTS IN THE CONSTRUCTION OF GRAIN-STRIPPING MACHINES.

LETTERS OF REGISTRATION to John Furphy, for Improvements in the Construction of Grain-stripping Machines.

[Registered on the 6th day of October, 1883, in pursuance of the Act 16 Vic. No. 24.]

BY HIS EXCELLENCY THE RIGHT HONORABLE SIR AUGUSTUS WILLIAM FREDERICK SPENCER LOFTUS (commonly called LORD AUGUSTUS LOFTUS), Knight Grand Cross of the Most Honorable Order of the Bath, a Member of Her Majesty's Most Honorable Privy Council, Governor and Commander-in-Chief of the Colony of New South Wales and its Dependencies.

TO ALL TO WHOM THESE PRESENTS SHALL COME, greeting :

WHEREAS JOHN FURPHY, of Wyndham-street, Shepparton, in the Colony of Victoria, blacksmith, hath by his Petition humbly represented to me that he is the author or designer of a certain invention or improvement in manufactures, that is to say, of an invention entitled "Improvements in the Construction of Grain-stripping Machines," which is more particularly described in the specification and the sheet of drawings which are hereunto annexed; and that he, the said Petitioner, hath deposited with the Honorable the Treasurer of the said Colony of New South Wales the sum of Twenty Pounds sterling, for defraying the expense of granting these Letters of Registration, as required by the Act of Council, sixteenth Victoria, number twenty-four; and hath humbly prayed that I would be pleased to grant Letters of Registration, whereby the exclusive enjoyment and advantage of the said invention or improvement might be secured to him for a period of fourteen years: And I, being willing to give encouragement to all inventions and improvements in the arts or manufactures which may be for the public good, and having received a report favourable to the prayer of the said Petition, from competent persons appointed by me to examine and consider the matters stated therein and to report thereon for my information, am pleased, with the advice of the Executive Council, and in exercise of the power and authority given to me by the said Act of Council, to grant, and do by these Letters of Registration grant unto the said John Furphy, his executors, administrators, and assigns, the exclusive enjoyment and advantage of the said invention or improvement, for and during the term of fourteen years from the date hereof; to have, hold, and exercise unto the said John Furphy, his executors, administrators, and assigns, the exclusive enjoyment and advantage thereof, for and during and unto the full end and term of fourteen years from the date of these presents next and immediately ensuing, and fully to be complete and ended: Provided always, that if the said John Furphy shall not, within three days after the granting of these Letters of Registration, register the same in the proper office in the Supreme Court, at Sydney, in the said Colony of New South Wales, then these Letters of Registration, and all advantages whatsoever hereby granted, shall cease and become void.

In witness whereof, I have hereunto set my sign manual, and have caused the present Letters of Registration to be sealed with the seal of the said Colony of New South Wales, at Government House, Sydney, in New South Wales, this fourth day of October, in the year of our Lord one thousand eight hundred and eighty-three.

[L.s.]

AUGUSTUS LOFTUS.

*Improvements in the Construction of Grain-stripping Machines.*

SPECIFICATION of JOHN FURPHY, of Wyndham-street, Shepparton, in the Colony of Victoria, blacksmith, for an invention entitled "Improvements in the Construction of Grain-stripping Machines."

My invention relates first and mainly to a new method of and appliances for raising and lowering the front of grain-stripping machines, so as to accommodate themselves to the varying height of the crops which they strip. Hitherto this raising and lowering has been accomplished by hand labour, whereas I make the motion of the machine to accomplish it, and so throw the labour of doing it on the power which draws or impels the machine along. Practically, this is a great advantage, because the driver has only to throw the raising and lowering contrivances into gear in order to raise or lower the machine at will, and without stopping its progress, instead of having to use considerable personal exertion in order to effect the same object. The raising and lowering gear may, of course, be made in various ways, and may be thrown in and out of gear with some moving part of the machine by a variety of means, without departing from the nature of my invention; but I have shown in my drawings the best means and appliances known to me for carrying it into effect.

The second part of my invention relates to the method of setting the main body of the machine on its framing. Hitherto they have been set parallel to the line of draught, whereas I set them obliquely to the line of draught, in order that they may have greater storage capacity, and in order that the driving wheel may support a greater portion of the weight, and so obtain a better hold on the ground.

These improvements are clearly illustrated in my drawings, in which figure 1 shows side elevation and figure 2 plan of a machine, embodying both my improvements. Figures 3 and 4 represent, on a larger scale, some of the details which will be identified by the letters of reference marked thereon and hereinafter referred to. In the other three spaces, divided off by border lines, are representations of three sets of appliances for raising and lowering the front of the machine, different from those represented in figures 1 and 2, but embodying the same principle of construction, viz., the application of the motion of the machine for the purpose just mentioned.

Referring now to figures 1, 2, and 4, in order to explain the second part of my invention it will be seen that the body A of the machine is set obliquely to the line of draught, necessitating an alteration in the arrangement of the wheels and axles, B and C, as clearly shown. The gear for driving the beater shaft is also necessarily somewhat altered, although I make no claim for its exclusive use. The pinion D gears into teeth on the inner periphery of annulus E, as usual, although the teeth are set at an angle, as shown. D<sup>1</sup> is a driving pulley keyed on to projecting boss of pinion D, which revolves on spindle D<sup>2</sup>, fastened into bell crank D<sup>3</sup>, working on shaft D<sup>4</sup>, which is attached to hinder axle as shown in figure 2. It will be seen that by raising or lowering hand-lever D<sup>5</sup>, pivoted at D<sup>6</sup> on frame of machine, the bell crank (carrying spindle, on which pinion D with driving pulley D<sup>1</sup> attached revolves) is moved forward or backward, consequently throwing pinion D in or out of gear as desired. The driving pulley D<sup>1</sup>, by means of belt, imparts motion to pulley D<sup>7</sup> on beater shaft. F is an iron stay.

Referring to figures 1, 2, and 3, in order to explain the first illustration of the first and main part of my invention, it is to be noted that the height of the front part of the machine is determined by the angle which rod or bar G is made to assume, the upper end of it at G<sup>1</sup> being affixed to the body of the machine, as shown, whilst the lower end G<sup>2</sup> is forked and connected to a female screwed nut G<sup>3</sup>, which works backward and forward on a horizontal screw H, according as such screw is revolved one way or the other. This screw receives its motion from one or other of two pinions, H<sup>1</sup> and H<sup>2</sup>, one of which, H<sup>1</sup> (see figures 2 and 3), is keyed on to the end of said screw, whilst the other, H<sup>2</sup>, revolves on pin fitted into rocking crank H<sup>3</sup> (through which said screw passes), pivoted in bracket H<sup>4</sup>, which is bolted to side frame of machine (see figure 2). The pinions gear into one another, and receive their motion from teeth on the face of annulus E. Which of these pinions is brought into gear with said annulus is determined by the motion of treadles J and J<sup>1</sup>, both of which are connected to spindle J<sup>2</sup>, passing through fixed bearing J<sup>3</sup>, the other cranked end passing into slot-hole in arm H<sup>5</sup> on said rocking crank H<sup>3</sup>. By pressing down J, the lower pinion H<sup>2</sup> is thrown into gear with said annulus, and so the screw H is made to revolve in one direction; while, by pressing down J<sup>1</sup>, the upper pinion H<sup>1</sup> is thrown into gear with said annulus, and the reverse motion obtained, by reason of its being driven direct from said annulus, instead of through loose pinion H<sup>2</sup>, previously described.

It will thus be seen that all that is required to effect the object I have in view in this part of my invention is to provide effective reversing gear, which shall be operated by some moving part of the machine, and connect it to any contrivances, old or new, by which the front part of the machine may be raised or lowered. Any kind of reversing gear, therefore, might be used to give motion to the raising and lowering contrivances, which may be of any kind suitable for the purpose. Therefore, without confining myself to any particular contrivances for effecting this nearly automatic method of raising and lowering the front of the machines to which my invention relates, I will now proceed to describe three other sets of mechanical contrivances by which it may be accomplished. Figure 5 shows side elevation and figure 6 plan of the first of these sets, in which the raising and lowering is accomplished by the raising and lowering of a screw, K, attached to a wooden beam or lever projecting from the front part of the body at K<sup>1</sup>, shown in dotted lines in figures 1 and 2, and passing through platform of machine at K<sup>2</sup>. This screw is raised and lowered by the revolution of a female nut K<sup>3</sup>, which on its outside is made in the form of a bevelled pinion. This pinion receives its motion from bevel wheel L on end of shaft L<sup>1</sup>, at other end of which is bevel pinion L<sup>2</sup>, receiving motion from one or other of bevel wheels M and M<sup>1</sup>, according as is determined by the motion of one or other of treadles N or N<sup>1</sup>. These treadles are each connected to spindle N<sup>2</sup>, attached to arm P on tube P<sup>1</sup>, enclosing shaft L<sup>1</sup>, which tube is also supported by lug P<sup>2</sup> from bracket P<sup>3</sup>, and at bevel wheel end by eye-bolt or bearing P<sup>4</sup>; so that by pressing down one other of the treadles the pinion L<sup>2</sup> is thrown into gear with one or other of the bevel wheels M or M<sup>1</sup>, and so the front of the machine is raised or lowered as required. There is an eccentric boss on the end of tube P<sup>1</sup> which works in eye-bolt P<sup>4</sup>.

Figures 7, 8, and 9 show plan, side, and front views of the second of my said sets of contrivances for raising and lowering the front of the machine. In this case a curved rack, Q, is attached to a beam projecting as before described from the front part of the body at Q<sup>1</sup>, into which rack there gears a spur pinion

*Improvements in the Construction of Grain-stripping Machines.*

pinion, R, on same spindle as tangent pinion R<sup>1</sup>, which receives motion from worm R<sup>2</sup> on spindle R<sup>3</sup>, to which motion is imparted in exactly the same way as it is imparted to horizontal screw H in figures 1, 2, and 3. This therefore needs no further description.

The rod R<sup>3</sup> in these figures may, if desired, be driven by the same contrivances as are shown in figures 5 and 6, and indeed this is the form of construction which I should prefer, in adapting this part of my invention to old machines, as being the most readily applied.

Figures 10, 11, and 12 show respectively side elevation, plan, and end view of the third of my sets of contrivances for raising and lowering the front of the machine. In this case a screw is attached to the front of the body, as in figures 5 and 6; by revolving it in one direction or the other, the raising or lowering is effected. This screw is revolved by means of tapped pulley V, supported in standard U, driven by belt V<sup>1</sup> from pulley V<sup>2</sup>, which is in the top of same spindle as pinion V<sup>3</sup> gearing into one or other of bevel wheels W or W<sup>1</sup>, as may be determined by the action of treadles X and X<sup>1</sup> through the medium of rod X<sup>2</sup> acting on arm X<sup>3</sup> of eccentric X<sup>4</sup>, in which the spindle of pulley V<sup>2</sup> and pinion V<sup>3</sup> revolve. In this case the treadles are not moved up and down, but to and fro.

Machines might be made with a permanent tendency for the front to either rise or fall, and with contrivances for merely controlling that tendency; but I do not approve of such a method of construction. For new machines I prefer to use the contrivances shown in figures 1 to 4.

Having thus described the nature of my invention and the best appliances known to me for putting it into operation, I would have it understood that, with respect to the first and main part of my invention, I do not confine myself to any particular mechanical details for giving motion to the parts by the moving of which the raising and lowering of the front of the machine is effected, because this part of my invention consists in the application of the motion of the machine, through the medium of reversible driving gear, to the contrivances by which such raising and lowering are directly effected; and when once this principle of construction is stated, various mechanical contrivances can be devised for putting that principle into practical operation. And further, as to the second part of my invention, I do not confine myself to any particular angle at which the body of the machine is set, so long as it is obliquely to the line of travel. Lastly, I wish it to be understood that the first and main part of my invention has no necessary connection with the second, and that each may be used quite independently of the other.

What I believe to be new, and therefore claim as my improvements in the construction of grain-stripping machines, is—

First and mainly—The combination of contrivances, the motion of which directly effects the raising and lowering of the front of the machine, with reversible driving gear operated by some moving part of the machine.

Second—The combination and arrangement of the mechanical contrivances for effecting the raising and lowering of the front of the machine, as shown in figures 1 to 4, and marked G to J<sup>3</sup>, both inclusive.

Third—The alternative combination and arrangement shown in figures 5 and 6, and marked K to P<sup>2</sup>, both inclusive.

Fourth—The alternative combination and arrangement shown in figures 7, 8, and 9, and marked Q to R<sup>3</sup>, both inclusive.

Fifth—The alternative combination and arrangement shown in figures 10, 11, and 12, both inclusive.

Sixth—Constructing grain-stripping machines, with their bodies set obliquely to the line of travel, substantially as herein described and explained, and the special construction and arrangement of the body and its framing, as illustrated in figures 1 and 2.

In witness whereof, I, the said John Furphy, have hereunto set my hand and seal, this first day of August, one thousand eight hundred and eighty-three.

Witness—

EDWD. WATERS,  
Patent Agent, Melbourne.

JOHN FURPHY.

This is the specification referred to in the annexed Letters of Registration granted to John Furphy, this 4th day of October, A.D. 1883.

AUGUSTUS LOFTUS.

### REPORT.

Sir,

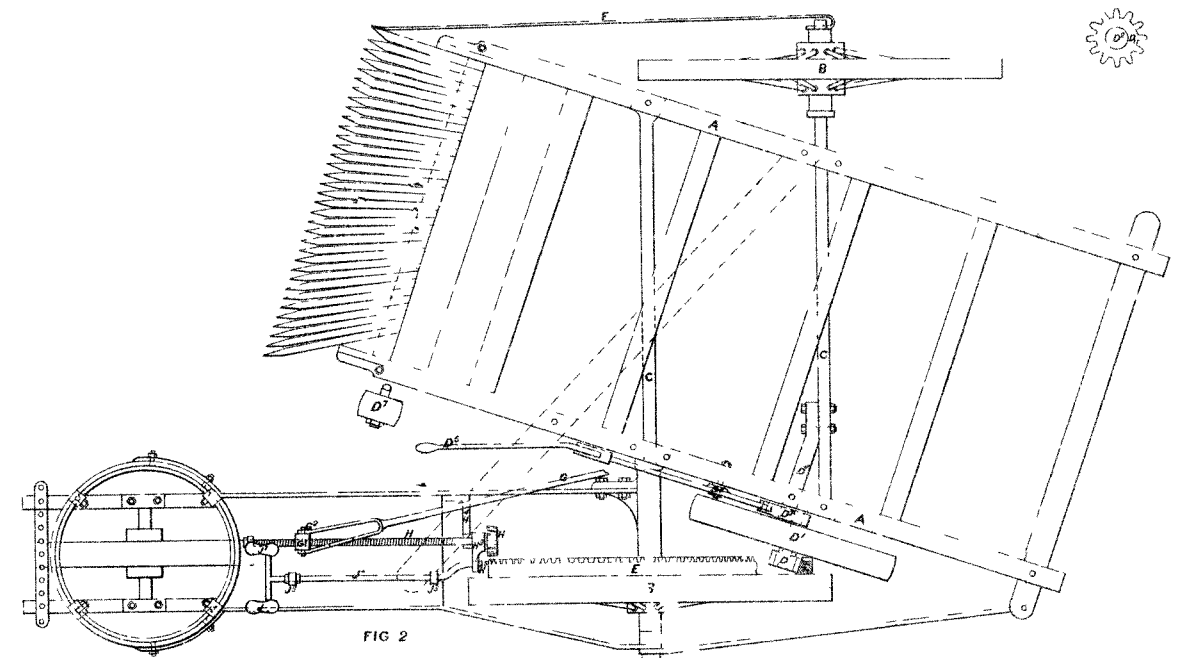
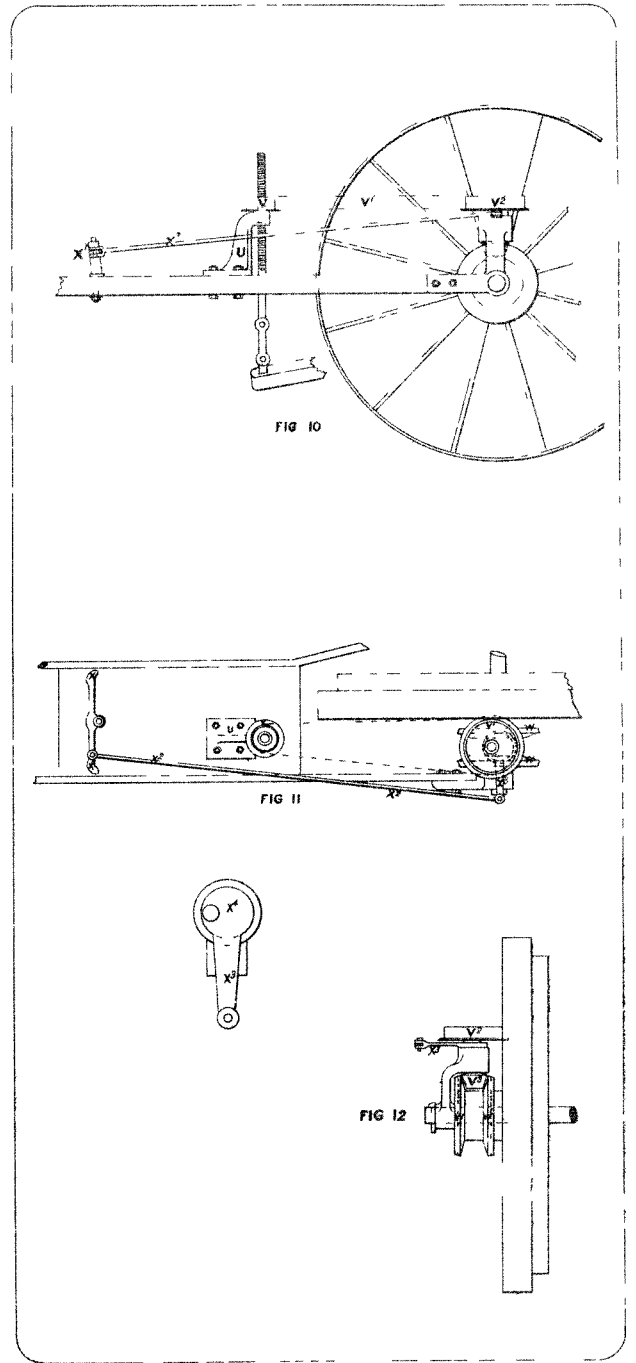
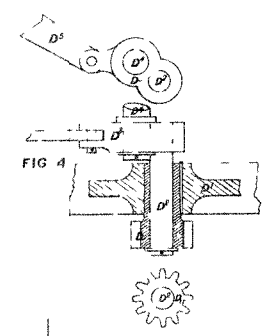
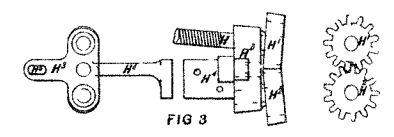
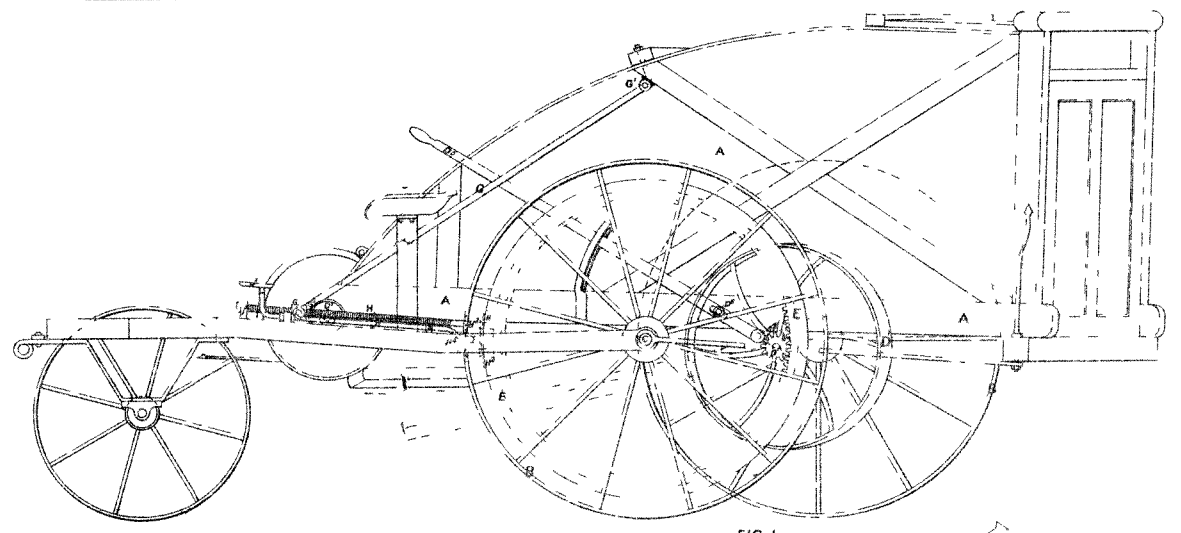
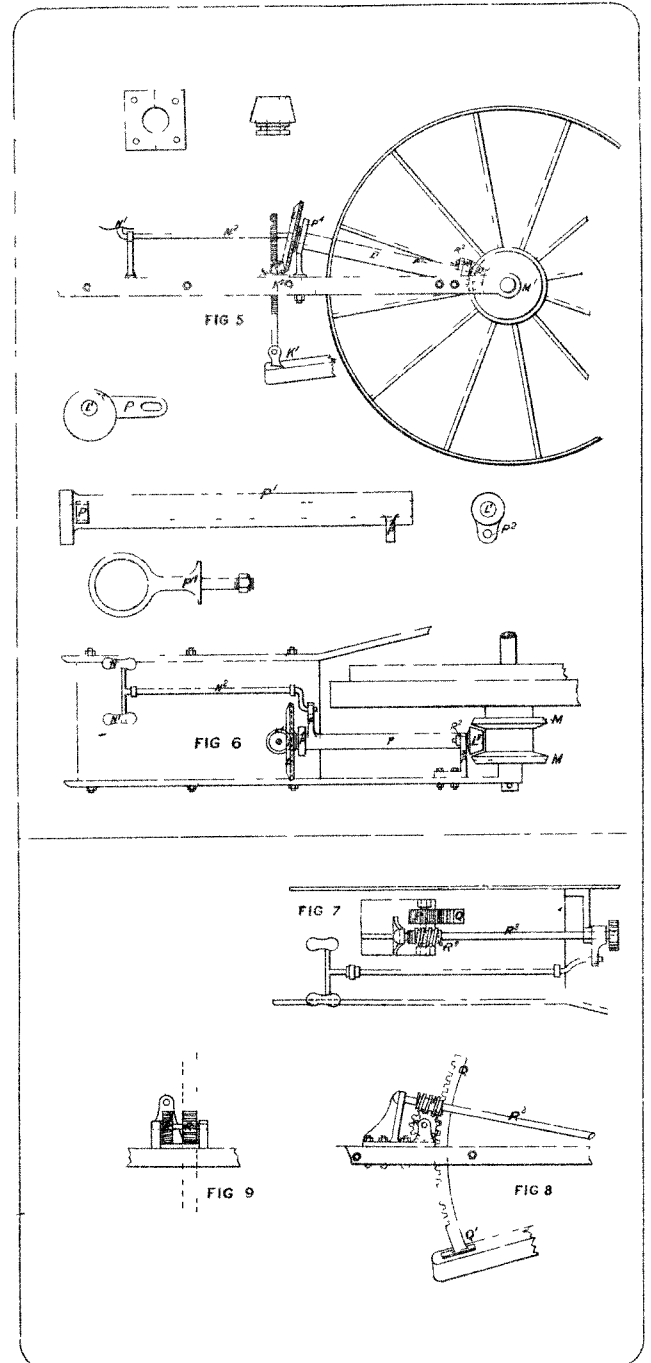
We do ourselves the honor to report, in reply to your blank cover of the 4th instant, No. 10,002, transmitting Mr. John Furphy's Petition for the registration of an invention entitled "Improvements in the Construction of Grain-stripping Machines," that we are of opinion the prayer of the Petitioner may be granted in terms of his specification, drawings, and claim.

We have, &c.,  
GOTHER K. MANN.  
EDMUND FOSBERY.

The Under Secretary of Justice.

[Drawings—one sheet.]

J. FURPHY'S PATENT



This is the Sheet of Drawings referred to in the annexed Letters of Registration granted to John Furphy, this 4<sup>th</sup> day of October A D 1883.

Augustus Loftus.

(Sig. 245-)



A.D. 1883, 4th October. No. 1318.

IMPROVEMENTS IN ANNEALING CHILLED AND OTHER CASTINGS.

LETTERS OF REGISTRATION to Edwin Jenkins, Alexander Law, and William Price, for an improved process of Annealing Chilled and other Iron Castings.

[Registered on the 6th day of October, 1883, in pursuance of the Act 16 Vic. No. 24.]

BY HIS EXCELLENCY THE RIGHT HONORABLE SIR AUGUSTUS WILLIAM FREDERICK SPENCER LOFTUS (commonly called LORD AUGUSTUS LOFTUS), Knight Grand Cross of the Most Honorable Order of the Bath, a Member of Her Majesty's Most Honorable Privy Council, Governor and Commander-in-Chief of the Colony of New South Wales and its Dependencies.

TO ALL TO WHOM THESE PRESENTS SHALL COME, greeting:

WHEREAS EDWIN JENKINS and ALEXANDER LAW, both of Exhibition-street, Melbourne, in the Colony of Victoria, founders, and William Price, of Pitt-street, Carlton, in the said Colony, ironworker, have by their Petition humbly represented to me that they are the authors or designers of a certain invention or improvement in manufactures, that is to say, of an invention entitled "An improved process of Annealing Chilled and other Castings," which is more particularly described in the specification which is hereunto annexed; and that they, the said Petitioners, have deposited with the Honorable the Treasurer of the said Colony of New South Wales the sum of Twenty Pounds sterling for defraying the expense of granting these Letters of Registration, as required by the Act of Council, sixteenth Victoria, number twenty-four; and have humbly prayed that I would be pleased to grant Letters of Registration, whereby the exclusive enjoyment and advantage of the said invention or improvement might be secured to them for a period of fourteen years: And I, being willing to give encouragement to all inventions and improvements in the arts or manufactures which may be for the public good, and having received a report favourable to the prayer of the said Petition, from competent persons appointed by me to examine and consider the matters stated therein, and to report thereon for my information, am pleased, with the advice of the Executive Council, and in exercise of the power and authority given to me by the said Act of Council, to grant, and do by these Letters of Registration grant unto the said Edwin Jenkins, Alexander Law, and William Price, their executors, administrators, and assigns, the exclusive enjoyment and advantage of the said invention or improvement, for and during the term of fourteen years from the date hereof; to have, hold, and exercise unto the said Edwin Jenkins, Alexander Law, and William Price, their executors, administrators, and assigns, the exclusive enjoyment and advantage thereof, for and during and unto the full end and term of fourteen years from the date of these presents next and immediately ensuing, and fully to be complete and ended: Provided always, that if the said Edwin Jenkins, Alexander Law, and William Price, shall not, within three days after the granting of these Letters of Registration, register the same in the proper office in the Supreme Court at Sydney, in the said Colony of New South Wales, then these Letters of Registration, and all advantages whatsoever hereby granted, shall cease and become void.

In witness whereof, I have hereunto set my sign manual, and have caused the present Letters of Registration to be sealed with the seal of the said Colony of New South Wales, at Government House, Sydney, in New South Wales, this fourth day of October, in the year of our Lord one thousand eight hundred and eighty-three.

[L.S.]

AUGUSTUS LOFTUS.

*Improvements in Annealing Chilled and other Castings.*

SPECIFICATION of EDWIN JENKINS and ALEXANDER LAW, both of Exhibition-street, Melbourne, in the Colony of Victoria, founders, and WILLIAM PRICE, of Pitt-street, Carlton, in the said Colony, ironworker, for an invention entitled "An improved process of Annealing Chilled and other Iron Castings."

OUR improved process of annealing chilled and other iron castings consists essentially in suddenly immersing them when at a given temperature in a liquid; and the object is to make them so that they can be punched, bored, tapped, and so on as readily as wrought metal. At present they are too brittle for this kind of treatment, but by our process they are converted into such a condition as to be readily manipulated in this way.

The particular point in the process is the temperature at which the metal is to be dipped into the liquid. This point is just when it is reduced to a dull red heat, when the redness is about to disappear.

The liquid in which it is immersed may be of any character not known to be inimical to the character of iron, such as acids and acid salts; but we have obtained the best results from a solution of treacle and water at a specific gravity of 1.005.

When the castings can be taken from the chill or from the sand sufficiently hot for the process, we dip them directly into the liquid; but when they cannot retain the proper heat for the act of dipping, we re-heat them in an oven or chamber a little beyond the necessary temperature, and then allow them to cool to the point of dull redness as before described, when we plunge them into a liquid as before stated, and allow them to cool, when the process is completed.

We have tried various kinds of liquids in which to dip the castings, and found them all to answer more or less well so long as acids and acid salts were avoided; but we have found that the solution of treacle and water at the gravity we have mentioned gives the best results. We do not however confine ourselves to any particular kind of liquid in which to dip the castings, but what we believe to be new, and therefore claim as our improved process of annealing chilled and other iron castings, is:—

The sudden immersion of such castings when at a dull red heat in a liquid, and preferably in a liquid consisting of treacle and water of a specific gravity of 1.005, substantially as and for the purposes herein described and explained.

In witness whereof, we, the said Edwin Jenkins, Alexander Law, and William Price, have hereunto set our hands and seals, this fourth day of May, one thousand eight hundred and eighty-three.

Witness—

EDWD. WATERS,  
Melbourne, Patent Agent.

EDWIN JENKINS.  
ALEXANDER LAW.  
WILLIAM PRICE.

This is the specification referred to in the annexed Letters of Registration granted to Edwin Jenkins, Alexander Law, and William Price, this fourth day of October, A.D. 1883.

AUGUSTUS LOFTUS.

### REPORT.

Sir,

We do ourselves the honor to report, in reply to your B.C. of the 8th June last, No. 83/6,973, that we are of opinion that the prayer of Messrs. Jenkins, Law, and Price for the registration of an invention entitled "An improved process of Annealing Chilled and other Iron Castings" may be granted in terms of their specification.

The Under Secretary of Justice.

Sydney, 7 August, 1883.

We have, &c.,

E. O. MORIARTY.  
JOHN WHITTON.



A.D. 1883, 4th October. No. 1319.

IMPROVEMENTS IN FURNACE BARS, &c.

LETTERS OF REGISTRATION to Fountain Livet, for Improvements in Furnace Bars, Flues, Expansion Chambers, and in Tubes of Steam Boilers.

[Registered on the 6th day of October, 1883, in pursuance of the Act 16 Vic. No. 24.]

BY HIS EXCELLENCY THE RIGHT HONORABLE SIR AUGUSTUS WILLIAM FREDERICK SPENCER LOFTUS (commonly called LORD AUGUSTUS LOFTUS), Knight Grand Cross of the Most Honorable Order of the Bath, a Member of Her Majesty's Most Honorable Privy Council, Governor and Commander-in-Chief of the Colony of New South Wales and its Dependencies.

TO ALL TO WHOM THESE PRESENTS SHALL COME, greeting :

WHEREAS FOUNTAIN LIVET, of London, England, hath by his Petition humbly represented to me that he is the author or designer of a certain invention or improvement in manufactures, that is to say, of an invention entitled "Improvements in Furnace Bars, Flues, Expansion Chambers, and in Tubes of Steam Boilers," which is more particularly described in the specification hereunto annexed, marked A, and the two sheets of drawings relating thereto and which are also hereunto annexed, and marked B and C, respectively; and that he, the said Petitioner, hath deposited with the Honorable the Treasurer of the said Colony of New South Wales the sum of Twenty Pounds sterling, for defraying the expense of granting these Letters of Registration, as required by the Act of Council, sixteenth Victoria, number twenty-four; and hath humbly prayed that I would be pleased to grant Letters of Registration, whereby the exclusive enjoyment and advantage of the said invention or improvement might be secured to him for a period of fourteen years: And I, being willing to give encouragement to all inventions and improvements in the arts or manufactures which may be for the public good, and having received a report favourable to the prayer of the said Petition, from competent persons appointed by me to examine and consider the matters stated therein and to report thereon for my information, am pleased, with the advice of the Executive Council, and in exercise of the power and authority given to me by the said Act of Council, to grant, and do by these Letters of Registration grant unto the said Fountain Livet, his executors, administrators, and assigns, the exclusive enjoyment and advantage of the said invention or improvement, for and during the term of fourteen years from the date hereof; to have, hold, and exercise unto the said Fountain Livet, his executors, administrators, and assigns, the exclusive enjoyment and advantage thereof, for and during and unto the full end and term of fourteen years from the date of these presents next and immediately ensuing, and fully to be complete and ended: Provided always, that if the said Fountain Livet shall not, within three days after the granting of these Letters of Registration, register the same in the proper office in the Supreme Court, at Sydney, in the said Colony of New South Wales, then these Letters of Registration, and all advantages whatsoever hereby granted, shall cease and become void.

In witness whereof, I have hereunto set my sign manual, and have caused the present Letters of Registration to be sealed with the seal of the said Colony of New South Wales, at Government House, Sydney, in New South Wales, this fourth day of October, in the year of our Lord one thousand eight hundred and eighty-three.

[L.S.]

AUGUSTUS LOFTUS.



*Improvements in Furnace Bars, &c.*

A

SPECIFICATION of FOUNTAIN LIVET, of London, England, for an invention entitled "Improvements in Furnace Bars, Flues, Expansion Chambers, and in tubes of Steam Boilers."

My invention relates—

First.—To a particular construction and arrangement of compound furnace bars composed of an upper removable portion fitting on to a lower portion which has a deep tapered wing varying in depth from front to back and with the space between every two bars diminishing in width from front to back of furnace, the whole resting on notched bearing bars, or furnished with separate distance pieces to keep them in their places side by side.

Secondly.—To setting the back portion of the furnace tube directly over the bridge, and also the bridge at a higher level at the back than at the front and parallel with each other.

Thirdly.—To increasing the flues in sectional area towards the damper, and making their bottoms of inverted arch form.

Fourthly.—To fitting or forming expansion chambers of large area compared to the flues at the end of each flue and rounding the tops level with the water-line of the boiler.

Fifthly.—To supporting the boiler at intervals upon saddle-shaped supports, the intermediate spaces being filled and closed in by a coping, which touch the boiler in a thin line only, and is composed of long coping bricks which can be pushed on one side to inspect the bottom of the boiler.

Sixthly.—To arranging Galloway tubes of diminishing diameters from front to back in a boiler, in order to increase the sectional area of the boiler flue to the back end.

Sevently.—To fitting rows of tubes vertically over each other, said row diminishing in diameter upwards, in order to form an expansion chamber of increasing area at the upper part.

My first improvement in fire-bars is shown in figures 1, 2, and 3 of the annexed drawings. A is the upper removable bar, shown grooved or filleted on its under surface at the ends, to find a bearing in corresponding apertures in the top of the lower bar, B, when fitted thereon. The bearing bar, upon which the bars rest, is notched to keep them steady in their places, and secure the continuity of the groove or opening between them, or they are provided with separate distance pieces fitted on the bearing bar for the same purpose. Centre portion of the upper bar is deeper than the two ends, and when the bar is more than 2 feet 9 inches long is provided with ribs or distance pieces, C, at each side. Other ribs, D, may be placed at the centre of the lower bars, B, for the same purpose. The wing of the lower bar is deeper at the front end than at the back, as shown at figure 3, and the bars are preferably arranged in sets as represented. The spaces between every two bars diminish from front to rear, as shown at figure 4, in order to diminish gradually the clear air space of the fire-grate.

The object of the division of the fire-bar into two parts is to avoid the unequal expansion and the consequent warping, buckling, and breaking, which would take place were the bar made in one piece of so great a depth, and also to facilitate and cheapen the renewal of the top part upon which the fuel rests.

The compound fire-bar is made as deep as the depth of the ash-pit will allow, preferably about 1 foot deep. It is also tapered evenly downwards from about 1 inch at the top to as sharp an edge as possible at the bottom, the spaces between every two bars of the several series for a furnace diminishing from  $\frac{3}{8}$  inch wide at the front to  $\frac{1}{4}$  inch at the back next the bridge, as shown by the plan view, figure 4.

The air in passing up into the furnace becomes heated to a high degree, and is properly directed without any disturbance from adverse currents, the tapered wings at the same time ensuring a gradual compression of the air in its passage upwards, so that it rises with proportionate rapidity and creates a strong and steady draught.

The second part of my invention is represented at figures 5 and 7 of the annexed drawings. The crown of the furnace-tube, E, being higher at the back, F, than at the front, G, and the top of the fire-bridge, H, being made parallel therewith. The object of this is to direct the current through the furnace upwards, instead of allowing it to escape horizontally as over an ordinary bridge, also to retain the gases longer in the furnace for the purpose of blending them, meanwhile allowing the heat to act direct on the whole of the crown surface of the furnace-tube before leaving the furnace.

The third part of my invention is represented at figures 9 and 10 of the annexed drawings, I being the first return flue of larger area than the boiler flue, but smaller than the next return flue, J. The bottoms, KL, of these flues are rounded, and also their tops, which terminate at the water-level, as at figure 10.

According to the fourth part of my invention, I form very large expansion chambers, MN, at each end of the boiler, the said chambers being carried down as low as possible to serve as soot receivers, as seen at figures 5, 8, 9, and 10.

The object of these expansion chambers being larger in proportion to the flues is that they may allow the gases to mingle and expand in the act of turning around the boiler, so as to check the draught at these points. The upper parts of the expansion chambers are also level with the water-level of the boiler, as shown.

According to the fifth part of my invention, as shown at figures 5, 9, 10, 11, and 14, PP are saddle-shaped supports under the longitudinal boiler. These supports are placed at intervals, and rest upon piers, having a foundation below the inverted arches, as shown more particularly at figure 5, the coping there shown just touching the shell of the boiler and filling up the spaces between these supports.

Figures 11, 12, 13, and 14 show an elephant boiler with conical connections, specially proportioned and adapted to the improvements herein described.

The next part of my invention is shown at figures 5, 8, and 9, in which the "Galloway" tubes, QQ, diminish in diameter from front to rear of the boiler flue, whereby the sectional area of the boiler flue is increased gradually to the back end.

In the arrangement of tubes in multitubular and marine boilers, forming the seventh part of my invention, I fit tubes of diminishing diameter over each other in vertical lines, as shown at figures 6 and 7,  
of

*Improvements in Furnace Bars, &c.*

of the annexed drawings, whereby I obtain a gradually increasing arc of the expansion chamber, from the lower to the upper rows of tubes, to allow steam to escape more freely from the tubes, and to expand naturally in rising, thus generating steam more rapidly and evenly, and avoiding priming.

Sometimes I make, say, two rows of such tubes of the same diameter, and the next two rows above them slightly smaller, and so on.

I have described my several improvements separately, but the bars are intended always to be used with the increased area of boiler flue, and with the expansion chambers in combination, whether for land or marine boilers.

Having now described the nature of my said invention, and in what manner the same is to be performed, I declare that I claim—

First.—The construction of furnace-bars composed of a lower and tapering web portion, and an upper portion fitting thereon, and kept in their places, and at equal distances laterally, as described and shown at figures 1, 2, 3, and 4, of the annexed drawings, said upper portion being of easy removal, for the purposes set forth.

Secondly.—I claim—Tapering the spaces between compound furnace-bars, gradually from the front to the back or bridge end, as shown at figure 4, for the proper regulation of the air supply to the fire, as described.

Thirdly.—I claim—Raising the back portion of the furnace-tube directly over the bridge, and also the bridge to correspond, as shown at figures 5 and 7 of the annexed drawings, for the purposes described.

Fourthly.—I claim—Increasing the sectional area of each course of flues in succession from the furnace to the damper, as shown at figures 9 and 10 of the annexed drawings, the chambers at the end of each course being also increased in sectional area, as and for the purposes described, with reference to figures 5, 8, 9, and 10.

Fifthly.—I claim—Supporting a steam boiler at intervals by saddle-shaped supports, the spaces between the supports being stopped off by a rounded top coping, which touches the boiler in a line only, as described and shown in figures 9 and 10 of the annexed drawings.

Sixthly.—I claim—Arranging "Galloway" tubes of diminishing diameter in the flue of a steam boiler from the furnace, and to the back, as and for the purposes described, and as shown at figures 5 and 8 of the annexed drawings.

Seventhly.—I claim—Fitting rows of flue tubes in boilers in vertical lines, each row diminishing in diameter upwards, as described, and as shown at figures 6 and 7 of the annexed drawings.

In witness whereof, I, the said Fountain Livet, have hereunto set my hand and seal, this second day of April, in the year of our Lord one thousand eight hundred and eighty-three.

FOUNTAIN LIVET.

Witness—

R. C. GARDNER,  
166, Fleet-street, London, England.

This is the specification marked A referred to in the annexed Letters of Registration granted to Fountain Livet, this fourth day of October, A.D. 1883.

AUGUSTUS LOFTUS.

---

REPORT.

---

Sir,

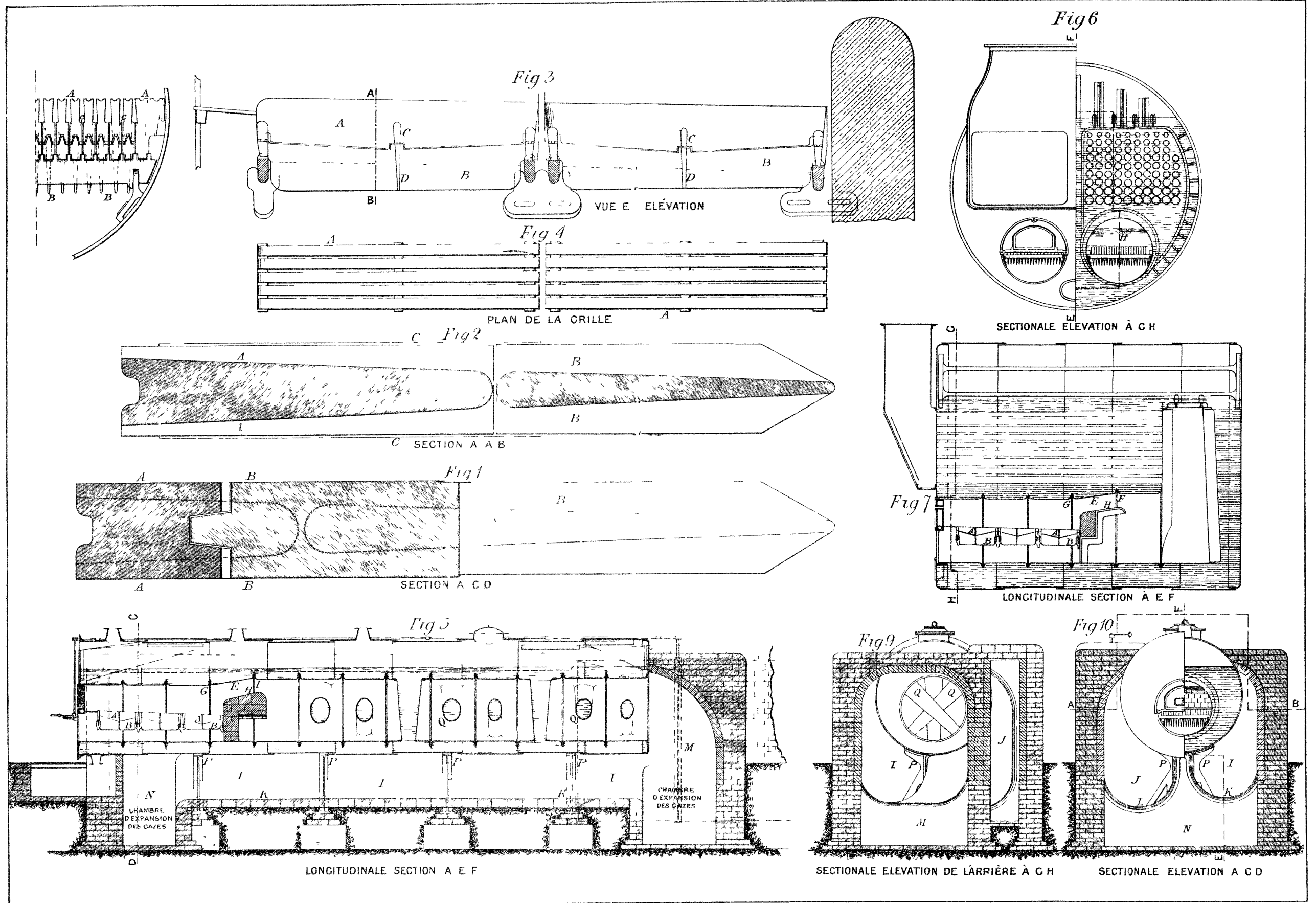
We do ourselves the honor to report, in reply to your blank cover of the 11th instant, No. 10,253, transmitting Fountain Livet's petition for the registration of "Improvements in furnace-bars, flues, expansion chambers, and tubes of steam boilers," that we are of opinion the prayer of the Petitioner may be granted, in terms of specification, drawings, and claim.

Sydney, 22 August, 1883.  
We have, &c.,  
E. C. CRACKNELL.  
GOTHER K. MANN.

The Under Secretary of Justice.

---

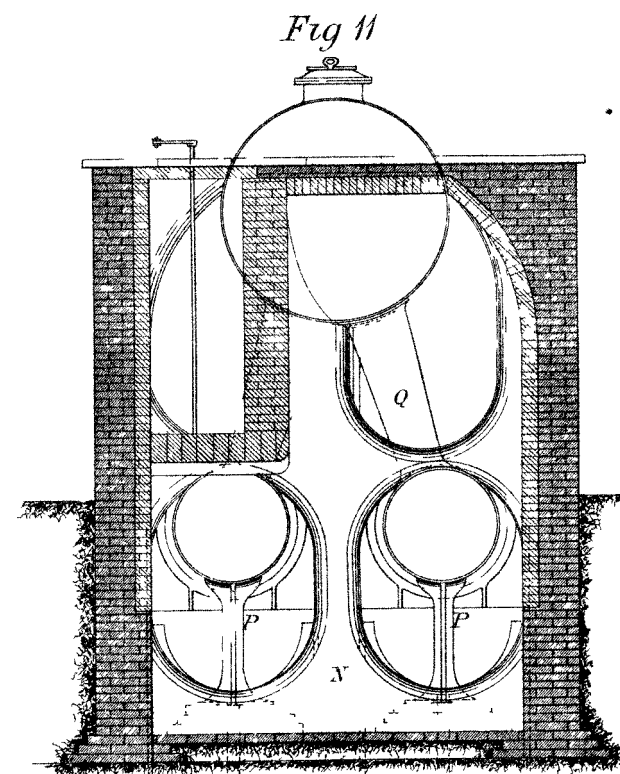
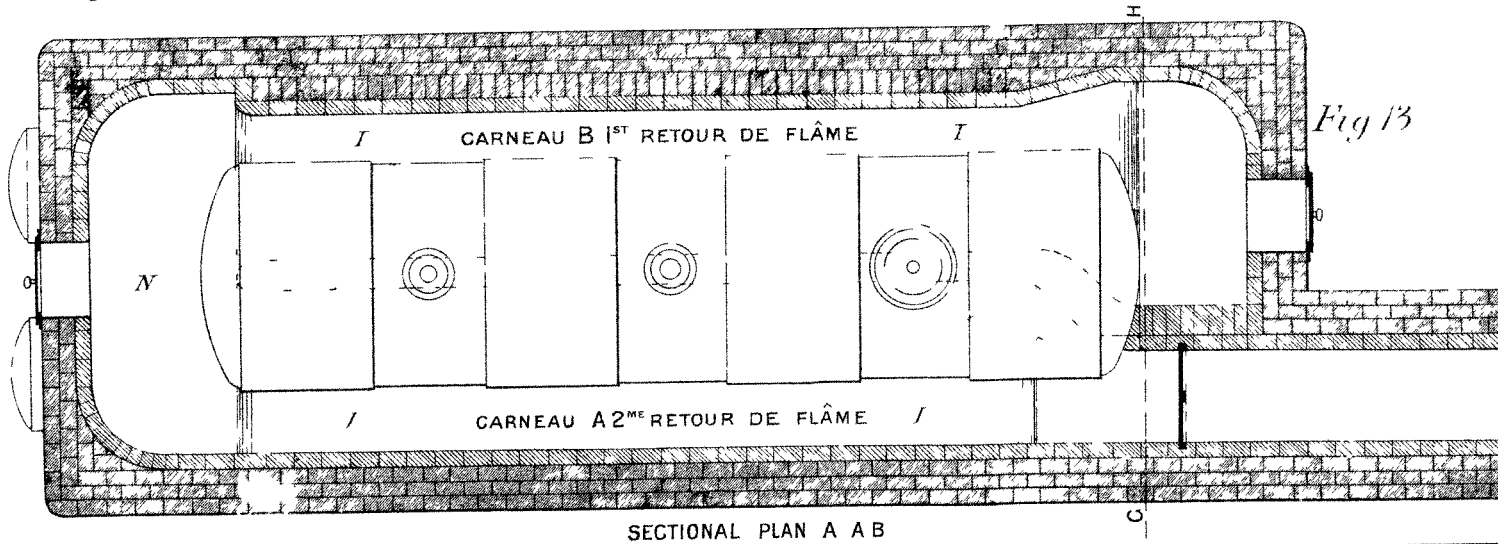
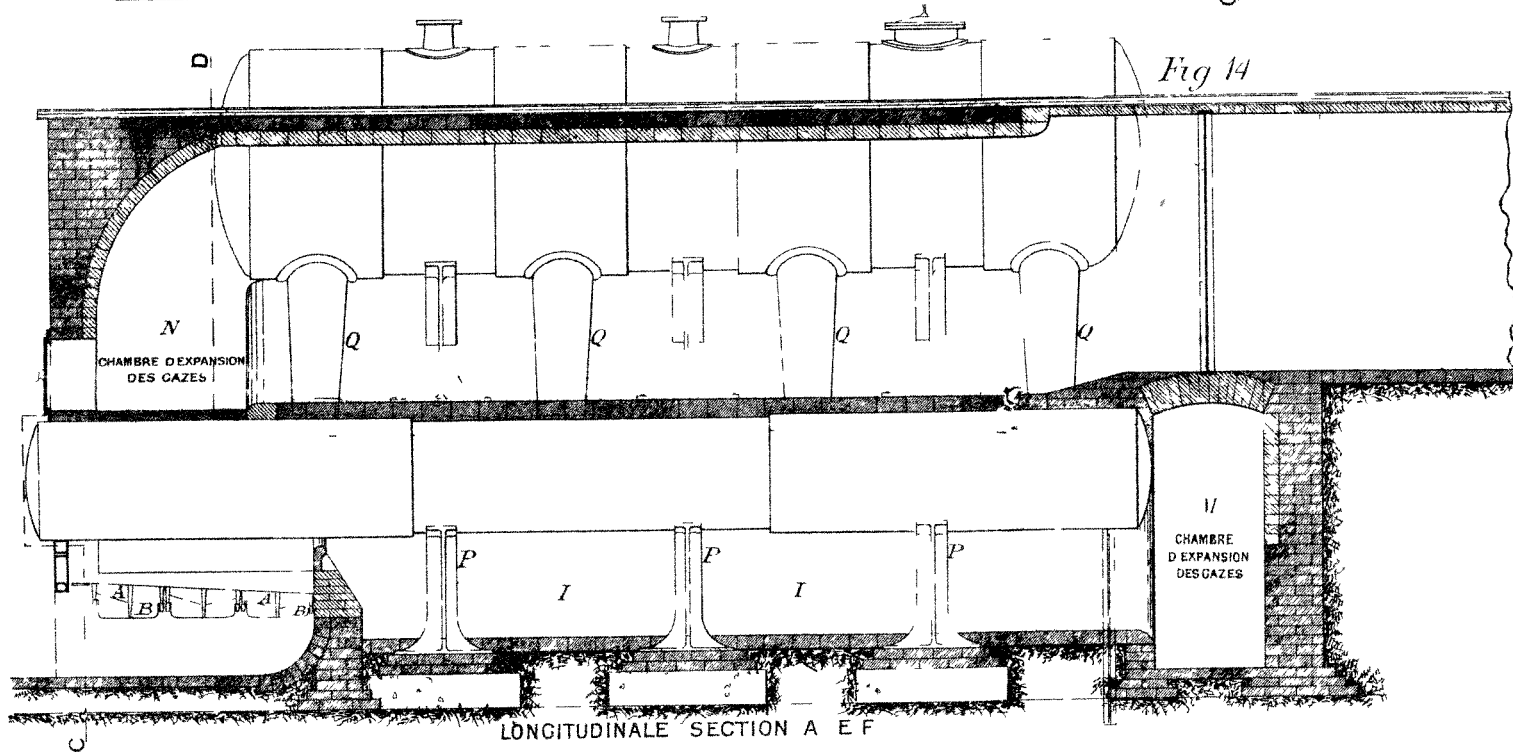
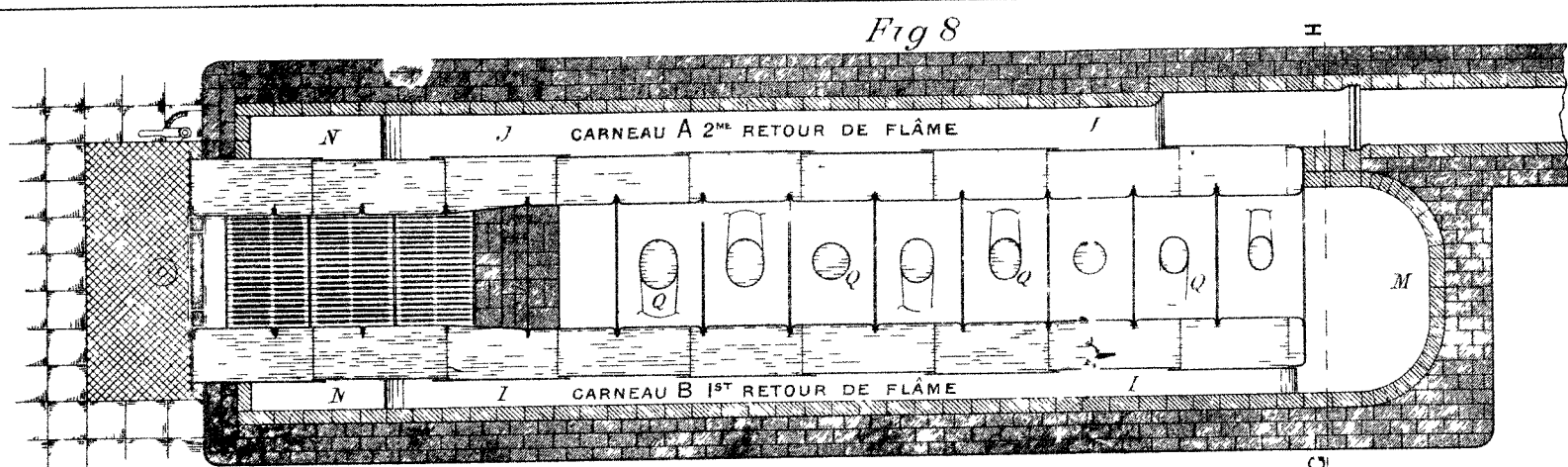
[Drawings—two sheets,]



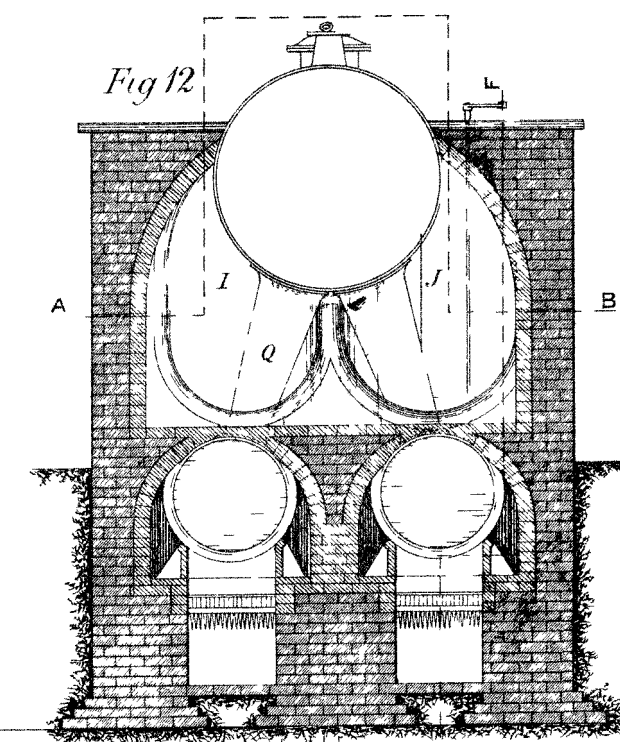
(Sig. 35.) This is the Sheet of Drawings marked B. referred to in the annexed Letters of Registration granted to Pounton Livet, this 4<sup>th</sup> day of October A.D. 1883.

Augustus Loftus.

PHOTO-LITHOGRAPHED AT THE GOVT. PRINTING OFFICE SYDNEY NEW SOUTH WALES



SECTIONALE ELÉVATION A G H



SECTIONALE ELEVATION DE L'ARRIÈRE A C D

(Sig 35-) This is the Sheet of Drawings marked C. referred to in the annexed Letters of Registration granted to Fountain Livet, this 4<sup>th</sup> day of October A. D 1883  
 Augustus Loftus.

PHOTO-LITHOGRAPHED AT THE GOVT. PRINTING OFFICE  
 SYDNEY NEW SOUTH WALES



A.D. 1883, 4th October. No. 1320.

IMPROVEMENTS IN MECHANISM USED FOR TRANSPORTING GOODS AND  
PASSENGERS BY THE AID OF ELECTRICITY.

LETTERS OF REGISTRATION to Fleeming Jenkin for Improvements in  
Mechanism used for Transporting Goods and Passengers by the aid of  
Electricity.

[Registered on the 6th day of October, 1883, in pursuance of the Act 16 Vic. No. 24.]

BY HIS EXCELLENCY THE RIGHT HONORABLE SIR AUGUSTUS WILLIAM FREDERICK SPENCER LOFTUS  
(commonly called LORD AUGUSTUS LOFTUS), Knight Grand Cross of the Most Honorable Order of  
the Bath, a Member of Her Majesty's Most Honorable Privy Council, Governor and Commander-in-  
Chief of the Colony of New South Wales and its Dependencies.

TO ALL TO WHOM THESE PRESENTS SHALL COME, greeting:

WHEREAS FLEEMING JENKIN, of 3, Great Stuart-street, Edinburgh, Scotland, hath by his Petition humbly represented to me that he is the author or designer of a certain invention or improvement in manufactures, that is to say, of an invention entitled "Improvements in Mechanism used for Transporting Goods and Passengers by the aid of Electricity," which is more particularly described in the specification which is hereunto annexed, marked A, and the four sheets of drawings, marked B, C, D, and E respectively; and that he, the said Petitioner, hath deposited with the Honorable the Treasurer of the said Colony of New South Wales the sum of Twenty Pounds sterling, for defraying the expense of granting these Letters of Registration, as required by the Act of Council, sixteenth Victoria, number twenty-four, and hath humbly prayed that I would be pleased to grant Letters of Registration, whereby the exclusive enjoyment and advantage of the said invention or improvement might be secured to him for a period of fourteen years: And I, being willing to give encouragement to all inventions and improvements in the arts or manufactures which may be for the public good, and having received a report favourable to the prayer of the said Petition, from competent persons appointed by me to examine and consider the matters stated therein and to report thereon for my information, am pleased, with the advice of the Executive Council, and in exercise of the power and authority given to me by the said Act of Council, to grant, and do by these Letters of Registration grant unto the said Fleeming Jenkin, his executors, administrators, and assigns, the exclusive enjoyment and advantage of the said invention or improvement, for and during the term of fourteen years from the date hereof; to have, hold, and exercise unto the said Fleeming Jenkin, his executors, administrators, and assigns, the exclusive enjoyment and advantage thereof, for and during and unto the full end and term of fourteen years from the date of these presents next and immediately ensuing, and fully to be complete and ended: Provided always, that if the said Fleeming Jenkin shall not, within three days after the granting of these Letters of Registration, register the same in the proper office in the Supreme Court, at Sydney, in the said Colony of New South Wales, then these Letters of Registration, and all advantages whatsoever hereby granted, shall cease and become void.

In witness whereof, I have hereunto set my sign manual, and have caused the present Letters of Registration to be sealed with the seal of the said Colony of New South Wales, at Government House, Sydney, in New South Wales, this fourth day of October, in the year of our Lord one thousand eight hundred and eighty-three.

[L.S.]

AUGUSTUS LOFTUS.



*Improvements in Mechanism used for Transporting Goods, &c., by Electricity.*

A.

[DUPLICATE.]

SPECIFICATION of FLEEMING JENKIN, of 3, Great Stuart-street, Edinburgh, Scotland, for an invention entitled "Improvements in Mechanism used for Transporting Goods and Passengers by the aid of Electricity."

THE object of my invention is the transmission of vehicles by electricity to a distance independently of any control exercised from the vehicle. I have given the name "Telpherage" to this system of transmission. "Telpherage" will be especially useful in the transmission of goods which can be readily subdivided into comparatively small parcels, inasmuch as my invention allows a light and cheap form of substructure to convey an almost continuous stream of vehicles at uniform speed and small cost.

The source of power is a fixed steam-engine, or other prime mover, driving a dynamo-electric machine. Any other adequate means of obtaining electric energy may be employed. The current produced is conveyed along the rope or rail supporting the vehicles, and drives the electro-motors which move the vehicles or trains of vehicles. The electro-motors are or may be governed so as to run at an approximately constant speed, and self-acting devices called blocking arrangements are or may be employed as a further precaution against collision. These blocking arrangements secure the condition that no train following another can approach within a given fixed distance without being deprived of its motive power, and, if necessary, stopped by the application of a brake. The vehicles, or trains of vehicles, are stopped, started, and shunted by persons who remain at the stations.

My invention may be conveniently described under four heads—

- A. The *propulsion*, or methods by which the current is supplied to the motor at all points on the line.
  - B. The *road and train*, or the way in which the vehicles are supported and guided, and the current conveyed.
  - C. The *governors* employed to regulate the speed automatically.
  - D. The *blocking* arrangements.
- A. There are two known systems by which a number of motors may be driven by an electric current derived from any source:—

1. The motors may be arranged in series.
2. The motors may be arranged in parallel arc.

I employ both these systems, which have each especial advantages, in special cases.

1. *The Series System.*—To carry this out, I divide the conductor (see diagram 1) into a series of equal insulated sections, numbered 1, 2, 3, 4, 5, &c. The conductor serves also to support the vehicles coupled as trains. A and B represent trains, of which only the leading and trailing wheels are shown. These trains are a little longer than each section of the conductor, or they may be made equal. Between the sections 1, 2, 3, 4, 5, switches or keys,  $s_1, s_2, s_3, s_4$ , &c., are placed. The object of these keys is to make and break contact between the sections. As a train proceeds, say in the direction of the arrow, a cam or other suitable mechanical device near the leading wheel moves each switch in succession so as to break contact between the sections, and another cam or other suitable mechanical device near the trailing end moves back each switch in succession, so as again to make contact. Electrical devices may be used instead of mechanical switches. Thus, in the diagram the contact is broken at  $s_1$  and  $s_3$ , but made at  $s_2$  and  $s_4$ . The electrical current runs continuously along the line through the closed switches until it reaches a train; here it leaves the main conductor; being stopped by the break at the switch, the current passes by a brush or wheel into the train, along the train through a motor propelling the train, and back into the main conductor on the other side of the switch. In this way a train can be propelled along a single rope or rail, and this is in itself novel. It is, further, clear that any number of trains with their motors coupled in series can be propelled along this single rope or rail.

2. A modification of this system is shown in diagram 2. It is adapted to the driving of motors coupled in series, when it would be inconvenient to have the train as long as the insulated section.

A motor and vehicle, A, makes electrical connection between two ropes or rails divided into sections 1, 2, 3, 4, 5, 6, 7, &c. Switches  $s_1, s_2, s_3$ , &c., are provided. These switches make and break contact between the sections of the main conductor, which are opposite one another. As the vehicle proceeds in the direction of the arrow it breaks the connection by the switch which it passes, and at the same time closes the connection by the switch which it last opened. This latter operation it effects by a supplementary electrical arrangement such as the following:—Each switch, when opened, makes a contact, which sends a derived current back by a supplementary wire,  $a$ , to an electro-magnet,  $b$ , working an armature by which the previous switch is closed. This mode of driving is also novel.

3. *Parallel Arc System.*—Diagram 3 represents an arrangement by which I can drive one or any number of trains with their motors coupled as respects the main conductors in parallel arc along a single rope or rail. I may point out that there may be more than one motor in each train, and these might be in series.

The diagram shows an up-line and a down-line, each consisting of one rope or rail. They are divided into equal sections, each insulated from the ground and from the neighbouring sections, but cross-connections are provided, as shown by the dotted lines, so that 4 is joined to 6, and 5 to 3, &c. The arrangement of the trains and motors is similar to that required in the first system. The distance between the rubbers making contact between the road and the train being equal to the length of the insulated sections, a powerful electro-motive force is maintained by the dynamo or other source of electric energy, X, so as to render 4, 6, 2, 8, positive, while 1, 7, 3, 5, are negative. When a train bridges the insulating gap between two sections, a current, driving the motor, flows through the train from a positive to a negative section, as from 2 to 1 through A. In this arrangement there are no switches. This mode of propulsion is novel. One of the two conductors may be used as a stay, connecting the posts when an up and down line are not required.

4. I may also employ in Telpherage the ordinary two-conductor system, and I then prefer to let the trains run on a single rope, and use the second rope as a stay between the posts. This is shown by diagram 3<sup>a</sup>. B

*Improvements in Mechanism used for Transporting Goods, &c., by Electricity.*

B. *The Road and Train.*—I employ, by preference, as my road, a single strained and insulated metal rope, rod, or rail, supported on posts. Each insulated section of the main conductor is a length of metal rope, rod, or rail, which may be secured to a ring of insulating material, as shown in figure 4.

In figures 5 to 9 more perfect modes of supporting and insulating the road are shown in some detail.

I employ two types of insulator, which I will term the abutment insulator and the rocking insulator. The abutment insulator is employed wherever there is discontinuity of stress in the strained rope or rod. The rocking insulator is employed when the successive spans of rope or rod are so joined that the stress from one span is continued to the next.

In figure 5 two pairs of abutment insulators are shown on the top of a post. Each insulator takes the whole stress of the rope. The peculiarities of the insulator are—The employment of a tension member, *b*, and a compression member, *a*, with feet spread a considerable distance apart; the arrangement of these members so that their axis intersects at *c* in or near the line of the rope; the narrow insulating cap, *d*, embracing those members; the metallic cover or bonnet, which at the same time forms the horn-piece *e*, supporting the rope, curved in one or in two places as the line is straight or curved.

In the drawing the two abutment insulators are fixed to a saddle, *f*, rocking on the pin *g*; but abutment insulators may be used, attached to a rigid support.

Figure 6 shows one form of rocking insulator. The rope is here shown continuous, but the same form of insulator is applicable when the two sections of the rope are more or less perfectly insulated from one another, as will be presently described. In figure 6 the rocking-pin *a* is itself insulated by the cap *d*, and the horn-piece *e*, curved in one or two planes, rocks on this pin. With this insulator a small cross strain will come on the supporting pillow *f*, when the span on one side is loaded and the other span unloaded.

In figure 7 the rocking pin *a* is not insulated, but supports the pillar *f*, which, in its turn, supports the insulating cap *d*, and this cap supports the metallic cap *e*, with the horn-piece curved in one or two planes. As has been already pointed out, the mechanical continuity of the rope shown in figures 6 and 7 does not imply electrical continuity, and in figures 8 the last-described insulator is shown in combination with electrical insulation of the section *m* from the section *n*. The horn-piece *e* now acts as a stretcher or connecting link between *m* and *n*, which are insulated by rings *o* and *p*. The insulation of *m* from *n* is of a much lower order than the insulation of the rope as a whole, all that is required being that a sufficient resistance should be interposed between them to send the bulk of the current through the motor when the switch used in my series system breaks the metallic contact between *m* and *n*.

A mechanically less perfect, but nevertheless useful, insulation may be made, as shown in figure 9, by omitting the rocking pin *a* of figure 7, and making the pillar *f* as in figure 6, but stronger. The horn-piece *e* would still be curved in one or in two planes. The rope would slip over the saddle or horn-piece *e*, and the stress on *f* would be limited to the force transmitted by friction. A slipping saddle or shoe, rolling as in suspension bridges, would still further diminish the cross strain on *f*. The horn-pieces are curved in a vertical plane to facilitate the passage of vehicles without a jump or sudden shock. They are curved on a horizontal plane to facilitate the passing of angles, and the rocking, slipping, or rolling equalizes the stress on the ropes. These are important features in Telpherage roads, irrespective of the other parts of my invention.

On the metal ropes, rods, or rails the carriages and vehicles may run, as shown in figure 10, which shows an up and down line on one post. There is nothing new in this arrangement of the vehicles, and I may employ other well-known arrangements of the load and supporting wheels. The electro-motor may propel itself by the adhesion due to the weight on the driving wheels, or by special gripping pulleys.

One form of suitable locomotive is shown in figures 11, 12, and 13:—

11 is a view in vertical cross-section on a plane perpendicular to the rope.

12 is a side elevation.

13 a plan.

M shows the motor with its centre of gravity under the rope R. This motor M, by what I will call right-angle nest-gearing, N, drives the wheel O. This wheel, by right-angle nest-gearing, drives the pulleys, P Q, which grip the rope and propel the train. The gripping action is peculiar and novel, being designed to avoid all unnecessary friction. Two rollers or pulleys, S T, which revolve together, press against the periphery of P and Q, being pressed together by the spring U. The roller S slides on a feather longitudinally, while the pulleys P and Q are so hung that they can approach and grip the rope. The force of the spring U causes no pressure on any of the four axles. The action by which M drives O will be understood by observing that the gearing has the same letters as those employed for the gripping action. The axes of *p* and *q*, like those of P and Q, are kept in a line parallel to that of the driving axis, but are free to approach and nip the rim of O. The inclination of M is not essential. If it were horizontal, the rollers *p* and *q* should have curved rims and bear at a point.

The weight of the locomotive is taken by two flat rollers, A and B, with a short wheel base. The merits of the special locomotive are:—1. The frictionless nipping. 2. The frictionless gearing. 3. The facilities given for turning. 4. The spring arrangement, by which small variations in the width of the road would not injure the parts. 5. The perfect action, no matter what the swing may be. 6. Prevention of fore and aft swing. 7. The guiding which the nip gives with no flanges. 8. The facility for the adjustment of the position of the centre of gravity. Habitually A and B would be insulated.

Two other varieties of locomotive are shown diagrammatically in figures 14 and figures 14<sup>a</sup>. The gripping arrangements are those already described. The motor M is placed vertically. The motor drives the pulley Q by a special gearing, which I call concentric nest-gearing. The small pulley C, fast on the motor shaft, is pinched between a large ring, *f*, fast on the shaft of Q, and a loose pulley, *d*. This loose pulley is held up by *f*, and a pair of pulleys, *e*<sup>1</sup>, *e*<sup>2</sup>. These pulleys run in bearings. It will be seen that if sufficient pressure is in any way caused between the peripheries of these pulleys, C will drive *f*, and thus Q and P. The necessary pressure may be given in various ways, but that which I prefer is to put *d* slightly eccentrically to *f*, and provide means for varying the triangle made by the centres of *e*<sub>1</sub>, *e*<sub>2</sub>, and *c*, so as to grip the loose pulley *d* by abutting against *f*. The centres of *e*<sub>1</sub>, *e*<sub>2</sub>, and *c* should be free to move in and out from the centre of *f*, so that the pressure on their rims shall produce no pressure on their bearings.

In

*Improvements in Mechanism used for Transporting Goods, &c., by Electricity.*

In figure 14<sup>a</sup> a somewhat similar concentric nest-gearing is shown, but in this case the outer ring *f* is the loose ring *d*, *c*, *e*<sup>1</sup>, and *e*<sup>2</sup> are supported. The second form is suited for more rapid running.

In figures 15 a special and suitable carriage is shown. The weight is distributed between one bearing-roller, A, with flanges and two guiding-rollers, B, C, with inclined axes, the greater part being, by preference, thrown on the roller A. In this carriage, fore and aft swinging is prevented. The guiding is effected by an arrangement causing less friction than the ordinary V pulley, and the risk of leaving the rails is diminished. I do not limit myself to this form of carriage, but describe it as an improvement on the ordinary form.

As already stated, instead of the wire ropes, a series of flexible rods or bands, or a series of stiff girders may be employed, insulated from each other. Stiff girders are suitable for higher speeds than the flexible ropes, rods, or bands. In passing round rapid curves, bent girders or rails are preferable to ropes, and may be used in combination with them. Short, bent, stiff supports, curved to a moderate radius, called horn-pieces above, are habitually employed to ease the motion of the train, where two spans of rope meet at an angle. Metal stays between successive posts are useful, and, as has been stated, these stays may be used as supplementary electrical conductors. The roads described are novel, and the special electric locomotives, with gripping pulleys and two forms of nest-gearing, are novel, and the arrangements described under head B are suitable for carrying out the systems described under head A.

C.—*Governors employed to regulate the speed automatically.*—The simplest form of governor which might conceivably be employed to regulate the speed of the locomotives on a parallel arc system, would be one in which the divergence of weights from a rotating axis was employed to break a contact which should deprive the motor of current. I consider this plan impracticable, because, when running at about the required speed the contacts would chatter and cause an almost continuous blaze of sparks, wasting power and destroying the contacts. A great improvement is effected when the centrifugal governor is employed to make and break contacts across which only a small derived current passes. This current, by means of an electro-magnet and armature, or by means of a small relay electro-motor, works a switch which deprives the motor of its current, and, in the series system, completes the main circuit. This plan is a great improvement on the first suggested, because the switch can be worked with considerable force through an arc of half an inch or more, across which the voltaic arc will not be formed.

Figure 16 shows a diagram of the electrical connections required to work the first system described under head A.

A is the main circuit wire passing to and from a dynamo-electric machine. B is an electro-motor on this circuit. It has a centrifugal governor. The slider of the governor is marked C. D is a lever moved by the slider, and carrying two metal pieces, *d*<sup>1</sup>, *d*<sup>2</sup>, insulated from the lever and from each other, but connected, the one with the incoming and the other with the outgoing circuit wire A. E is a small auxiliary electro-motor controlling the main motor B. It is of such construction as to reverse its direction of rotation when the current through it is reversed. The simplest method of effecting this reversal is to employ a magneto-motor; but other methods can be used. F is a lever, moved by the motor E, and making contact with pieces *f*<sup>1</sup> and *f*<sup>2</sup>. The main circuit is through the lever F to one or other of the pieces *f*<sup>1</sup> or *f*<sup>2</sup>. When contact is made at *f*<sup>1</sup> the current passes on through the motor B; but when contact is made at *f*<sup>2</sup>, and not at *f*<sup>1</sup>, the current in the main circuit does not reach the motor B. The contacts *f*<sup>1</sup> *f*<sup>2</sup> are so arranged that the main circuit is never opened.

The auxiliary motor E remains at rest, except when the governor brings the lever D to such a position that the pieces *d*<sup>1</sup> *d*<sup>2</sup> upon it make contact with *d*<sup>3</sup> and *d*<sup>4</sup> on the one side, or with *d*<sup>5</sup> and *d*<sup>6</sup> on the other side.

When this takes place a portion of the current from the distant source flows through the auxiliary motor E, and a re-adjustment of the contacts at *f*<sup>1</sup> *f*<sup>2</sup> is effected, the lever F being moved one way or the other, according as it is by *d*<sup>3</sup> *d*<sup>4</sup> or by *d*<sup>5</sup> *d*<sup>6</sup> that the current passes.

By the addition of a simple slot in the part of the governor which actuates the primary contact piece the perpetual interference of the governor may be avoided and a certain latitude of speed given. Thus, in figure 17, let M be the actuating piece of the governor, with a slot, N, in which works the pin O of the primary contact-piece P. This contact-piece, P, is hinged with a little friction, so as to remain where it is placed; then, if brought by the governor to the stop *s*, in consequence of a superior limit of speed being passed, it will not be brought back to *t* until an inferior limit of speed is passed, which may differ by any desirable amount from the superior limit.

I prefer to employ a form of governor which will produce a more absolutely constant speed.

In the form of governor last described the effect produced by the governor is undone when the speed of the machine falls back to the normal speed or a little below it; but cases arise in which this is undesirable, as some permanent change may occur in the driving current or in the mechanical resistance to the train, as when the gradient changes. This renders a permanent re-adjustment of the electrical mechanism desirable, and I effect this automatically in the following way:—

I arrange a train of wheels, A, B, C, in such a manner that A drives B and B drives C, or, *vice versa*, C may drive B and B will then drive A. When B is turned in one direction it produces an electrical change, tending to increase the speed of the motor. When B is turned in the reverse direction this change is undone. One arrangement of this kind is shown in figure 18. The centrifugal governor is so arranged that when the speed is below a certain point an arm, D, presses against a smooth pulley or surface, *a*, connected with A. When the speed is above a certain point this arm presses against a smooth pulley or surface, *c*, connected with C. A and C are loose upon their axles. When the speed is intermediate between the two limits the arm D is clear of both surfaces and the three wheels stand still. An increase of speed turns B in one direction; a decrease turns it in the other.

B may then be employed to shunt or cut out a motor, to throw in or out electrical resistance, or to adjust brushes, or to adjust a magnetic or electric field, or to apply a mechanical or electrical brake, or, in fine, to produce any change, mechanical or electrical, which regulates the speed; and in this manner a permanent change may be effected which will not be undone when the motor is brought back to the desired speed.

An



*Improvements in Mechanism used for Transporting Goods, &c., by Electricity.*

An alternative arrangement is shown in figure 19, where the two wheels, A and C, are moved in and out of rubbing gear with B by the action of the centrifugal governor. The surfaces of the wheels are smooth and play the part of the rubbing surfaces, *a* and *c* in figure 11, but they also fulfil the function of the pitch surface of the wheels A and C.

The arm M is worked by a screw connected with B, and makes any desired electrical change.

It is clear that when such a piece as M is screwed to one limit of its range by an increase of speed it can be made to press against a contact-piece or a simple mechanical arm and apply a resistance to the motion of the motor; thus, resistance may be any known form of brake.

In other cases, when it may be necessary to apply a mechanical or electrical brake for a considerable length of time and then to remove it for a long period, as where great changes of gradient occur, I employ a moving piece, actuated as M is actuated in figure 19, to apply the brake only after the limit of speed has been exceeded for a given interval of time, which may be regulated. I effect this as follows:—

In figures 20, let the piece M be actuated by the governor so as to move downwards when the speed increase. When this motion has reached the limit at which the speed can be controlled, as already described, by cutting off the current entirely, a wedge, Q, actuates a catch, N, so as to release the cross-head O. The cross-head is pulled downward by springs S<sub>1</sub> S<sub>2</sub>, and its motion is resisted by a dashpot, P, or other contrivance, delaying the motion for the desired time. After the lapse of this time the cross-head O will fall down nearly to Q and make contact at T, so as to apply an electrical brake. The time between the release of the catch and the arrival of O at its limiting position may be, for instance, 30', yet, when the speed falls, the stop Q, attached to M, will, as soon as M begins to move back again, break the contact at T, and so take off the electrical brake. As M rises it will again set the catch N. The contact at T may be employed in many obvious ways to arrest the train, and, indeed, the mere mechanical pressure of the springs, S<sub>1</sub> S<sub>2</sub>, on a quick running wheel, instead of T, would in most cases be a sufficient brake. The dashpot, P, should not resist the upward movement of O. If a fan were employed instead of the dashpot, it should be driven by the descent of O, and not by its ascent.

All the new governing arrangements described are suitable for Telpherage, and they all require that the fixed dynamo shall supply current in excess of that which is required on the steepest gradient, since the function of the governor is to check the motor.

These electrical governing arrangements might be applied to other uses than Telpherage.

D.—*Blocking Systems.*—It is obvious that different blocking arrangements will be required for each arrangement of the road, as described under head A.

1. The block for the series system described under paragraph 1, head A, is shown by figure 21. In this arrangement, when the switch *s*<sub>3</sub> is moved so as to break contact between two sections, 3 and 4, it also makes a contact by which an electro-magnet, *e*, near the previous switch is actuated, and when so actuated the magnet maintains electrical connection between the sections 4 and 5 independently of the switch *s*<sub>4</sub>. Thus, in figure 21 the train B is blocked by the train A. Any number of sections behind the train may, in a similar way, be blocked.

From each magnet, *e*, an insulated wire, *f*, passes forward along the line to the end of the section and to a contact in connection with the switch there situate. Then the same movement which opens the interval between the sections connects the wire *f* with the main circuit, and causes it to divert a small portion of the current to its electro-magnet *e*. The magnet attracts its armature, closes the connection which it controls, and keeps it closed so long as the current passes in the magnet, notwithstanding the advance of a following train.

2. Block for modified system, also described under head A, paragraph 2.

In this arrangement the electro-magnets, *b*, *b*, &c., form a blocking system; for if, in diagram 2, a second train, A<sub>1</sub>, follows the train A, and momentarily opens the switch *s*<sup>3</sup>, this switch is instantly closed again by the action of *b*, and this cuts the current away from A. This plan of blocking, however, leaves the second train permanently blocked, and I prefer to employ a supplementary wire for the purpose of blocking, by a method similar to that already described. This method is shown in figure 22.

Let switches *s*<sup>1</sup>, *s*<sup>2</sup>, *s*<sup>3</sup>, &c., be ordinarily closed by a momentary current sent to the electro-magnets, *b*, *b*, &c., when the preceding switch passes over the contacts, *m*, *m*, &c., during the process of opening, and let the switches, as finally placed mechanically by train A, make contact at the stops *f*<sup>1</sup>, *f*<sup>2</sup>, *f*<sup>3</sup>, working electro-magnets K<sup>1</sup>, K<sup>2</sup>, K<sup>3</sup>. K has nothing further to do with the switch, but a short circuit, *h*, is established by K cutting out the blocked train, A<sub>1</sub>, until A has reached another section and restored *s*<sup>1</sup> to its normal position.

3. Both of these block systems require acting electro-magnets at each post or switch. In populous places, where the lines could be often inspected, these plans may be adopted; but where frequent inspection is difficult, I prefer the following alternative block systems, which may indeed be found preferable in all cases. I fix insulated lengths of wire, which I term block wires, alongside the main conductor or road.

I make two contacts between the train and the block wires—the one I call a trailing contact, near the end of the train; the other a leading contact, near the beginning of the train. The leading and trailing contacts of one train are never made with the same block wire. When a current passes through the leading contact it produces some effect calculated to stop the train. A current passing through the trailing contact produces no effect on that train; but passing along the block wire to a following train produces an effect calculated to stop any train, the leading contact of which is on that block wire, which thus acts as a sort of long feeler guarding the train. This system may be worked out in several ways, according to the perfection of blocking required. Figure 23 shows its very simplest application to system 1, head A.

1, 2, 3, 4 are sections of the main conductor.

*a*<sup>1</sup> *a*<sup>2</sup> *a*<sup>3</sup> *a*<sup>4</sup> are block wires of equal length. L and T are the leading and trailing connections. The train B has approached too near train A, and a derived current flows through T *a*<sup>2</sup> L<sub>B</sub>, and by an electro-magnet in L<sub>B</sub> short circuits the motor of B.

*Improvements in Mechanism used for Transporting Goods, &c., by Electricity.*

4. If A were itself to be blocked, or otherwise be stopped, near the beginning of a section, plan 3 would afford very little protection. I extend the protection to the next section by a second block-wire, as represented in figure 24. The block-wires are then arranged on a cross-over plan. It must be noted that these block-wires may be light and cheap.

The trailing connection makes contact with both the upper and the lower wires in the diagram, the leading connection with the upper wire only. The effect is to stop B one section further back than by plan 3. The same system may be adapted to protect a train two, three, or any number of sections back, fresh wires being added. The application of this system to system 2 head A is obvious.

5. I show, in figure 25, the application of the block-wire arrangement to the parallel arc system, as described under head A, paragraph 3.

This arrangement of block-wires is identical with that of the preceding section.

6. Telpherage might be carried out by driving the motors arranged in parallel arc between two continuous conductors, in the manner already used for electrical railways. In that case my blocking system will still be applicable, and is applied as follows:—In figure 26, P and N are the main conductors. The block-wires are a series of equally insulated conductors, which may be of any length,  $a^1 a^2 a^3 a^4 a^5$ . Each block-wire overlaps those which follow, and precede it to the extent of half their length, as shown in the diagram. A is a train free to proceed. B is a train which is blocked by A.

Each motor has two cross connections, T and L, which, by suitable rubbers, put the main conductors, P and N, in connection—one with the first half, the other with the second half of the block. In the leading cross connection L an electro-magnet is inserted, by which the motor is cut out, or any other desired change effected.

When a following train reaches a block wire which is still in contact with the trailing contact of a preceding train, a current will flow through the block-wire, and the leading cross connection of the following train, and so arrest it. In this case, as in the preceding method, carbon or some analogous substance must be employed for a part of the block-wire or cross connection, in order to give such resistance as to prevent an excessive current from flowing.

This simple method is applicable to Telpherage, but would not form a perfect guard to the preceding train, for if the following train overshot one half of a block-wire, the block would be removed and a collision might occur. The block-wires might be made so long as to render this highly improbable, but the block may be rendered more efficient by increasing the number of the block-wires. As an example, let there be three overlapping block-wires instead of two, each block-wire will then consist of three parts, called the first, second, and third. The leading cross connection, L, will then join a main conductor through a block electro-magnet to the third part of each successive block-wire. The trailing rubber of the train will join the other main conductor to the first part of one block-wire and to the second part of the next, as in diagram 27.

A following train will then be blocked by a preceding one, so long as the second train is passing over two-thirds of the length of a block-wire, and will only be released when within one-third of that length.

7. *General Remarks on the Blocking Systems.*—These systems are all novel. The block-wires, with the rubbers and cross connections, could be made to act in various ways analogous to those described, more especially by using polarized electro-magnets in place of simple electro-magnets; but I do not describe all the possible varieties, but only so much as will enable the designer of a line readily to select a suitable method. The use of any kind of block-wires with no mechanism on the line automatically to check and release a train driven by an electro-motor is novel. In both the parallel arc and series system the block is independent of the direction in which the preceding train has been moving, but if the preceding train has been moving back on the following train it will not itself be stopped. In Telpherage this backing is never required. A backing train can be automatically prevented from running back into a following one by arranging the mechanism so that when any train runs backwards a block electro-magnet is automatically inserted in what is properly the trailing cross connections.

I claim,—

First—Telpherage, carried out by any of the means herein described.

Second—The novel methods of electric propulsion described under head A.

Third—The novel constructions of road and locomotive carriage for electric transport described under head B.

Fourth—The novel electrical governors described under head C.

Fifth—The novel methods of blocking trains described under head D.

Sixth—The nest-gearing employed in electric transport.

Seventh—The novel construction of insulators, substantially as herein described, and as illustrated in figures 5 to 9 of the drawings.

Eighth—The horn-pieces, curved in two planes, for any form of electric transport.

The complete system of propulsion, road, motor, train, block, and governor constitute my complete invention, and each part in some form is necessary to carry it out completely, but it is obvious that, under special circumstances, certain parts may be left out, and also that certain parts are useful for other purposes than Telpherage.

In witness whereof, I, the said Fleeming Jenkin, have hereunto set my hand and seal this 20th day of April, 1883.

FLEEMING JENKIN.

This is the specification marked A, referred to in the annexed Letters of Registration granted to Fleeming Jenkin, this fourth day of October, A.D. 1883.

AUGUSTUS LOFTUS.

---

*Improvements in Mechanism used for Transporting Goods, &c., by Electricity.*

---

## REPORTS

Sir,

We do ourselves the honor to report, in reply to your blank cover of the 6th instant, No. 6,768, that we are of opinion Letters of Registration may be granted in favour of Fleeming Jenkin for "Improvements in Mechanism used for Transporting Goods and Passengers by aid of Electricity," with the exception of so much of his first claim as set forth in the words following the word "described," and with the exception of the 7th and 9th clauses.

We have, &amp;c.,

E. C. CRACKNELL.  
GOTHER K. MANN.

The Under Secretary of Justice.

Sydney, 22 June, 1883.

Sir,

We do ourselves the honor to report, in reply to your blank cover of 28th June, No. 7,903, *re* Mr. Fleeming Jenkin's application for Letters of Registration, that we are of opinion the prayer of the Petitioner may now be granted, in accordance with his revised claims.

We have, &amp;c.,

E. C. CRACKNELL.  
GOTHER K. MANN.

The Under Secretary of Justice.

Sydney, 16 August, 1883.

---

[Drawings—four sheets.]

Fig<sup>s</sup> 5.

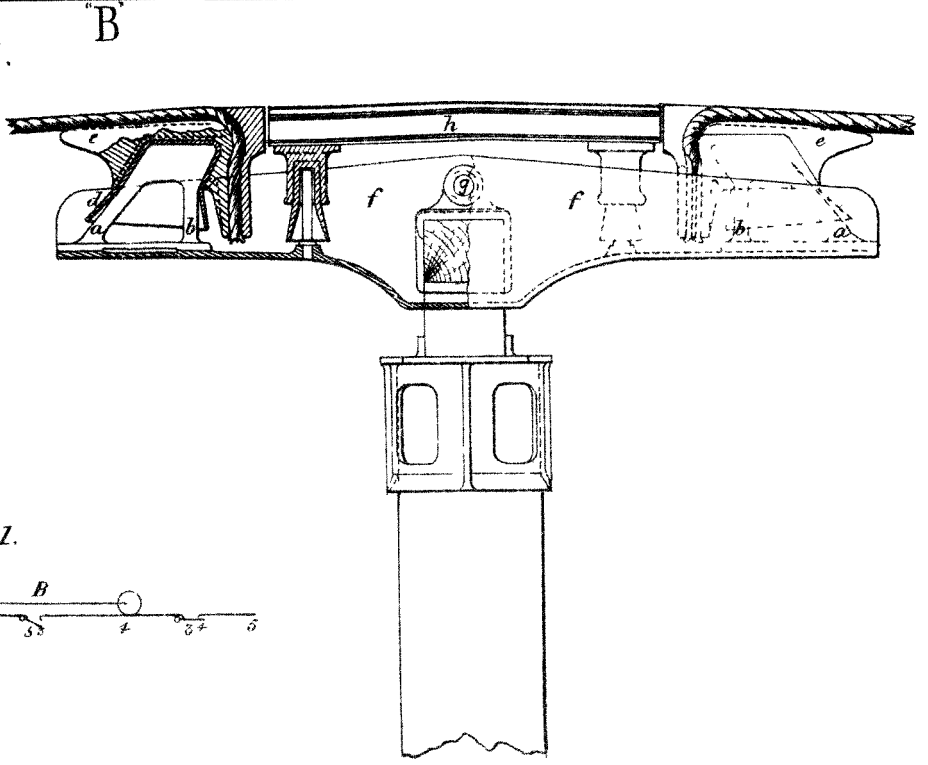
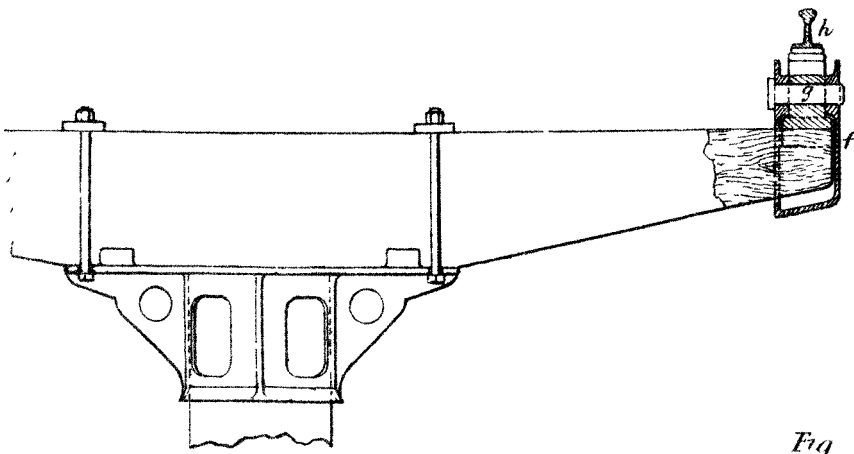


Fig 1.

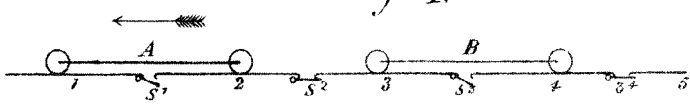


Fig. 2.

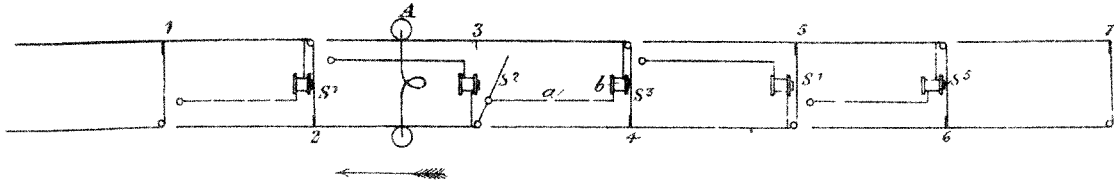


Fig. 3.

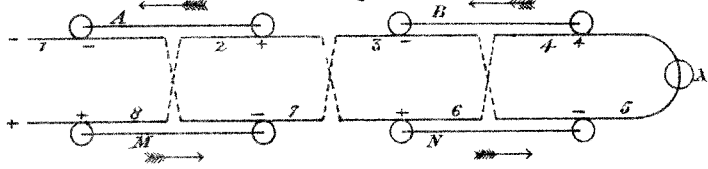


Fig. 4.

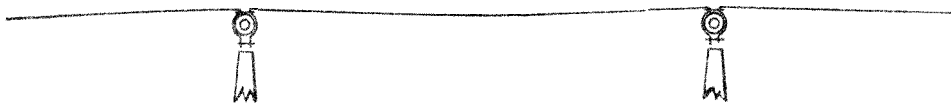


Fig. 6.

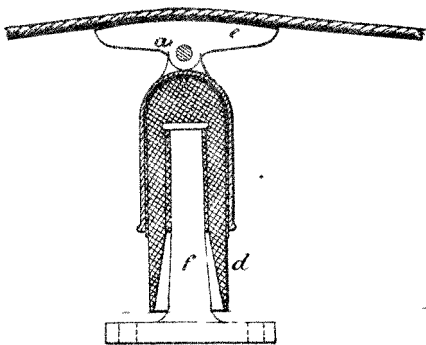
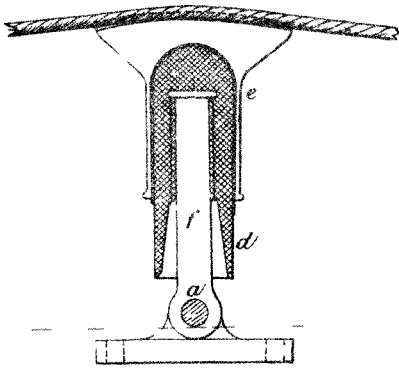


Fig. 7.



Fig<sup>s</sup> 8

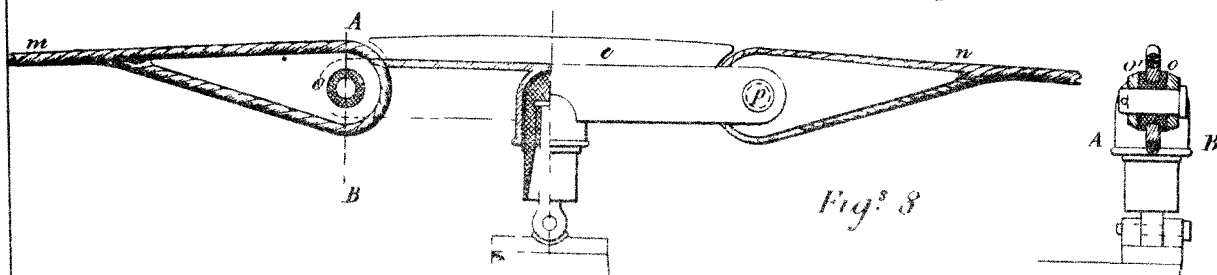


Fig. 9.

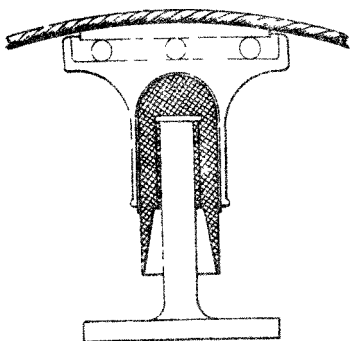


Fig. 10.

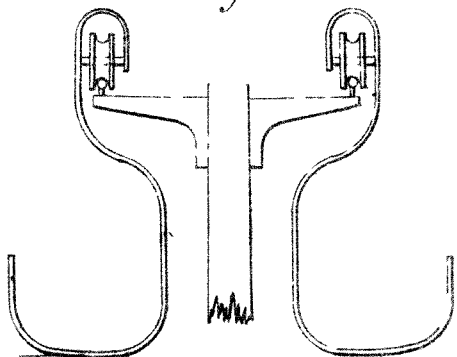
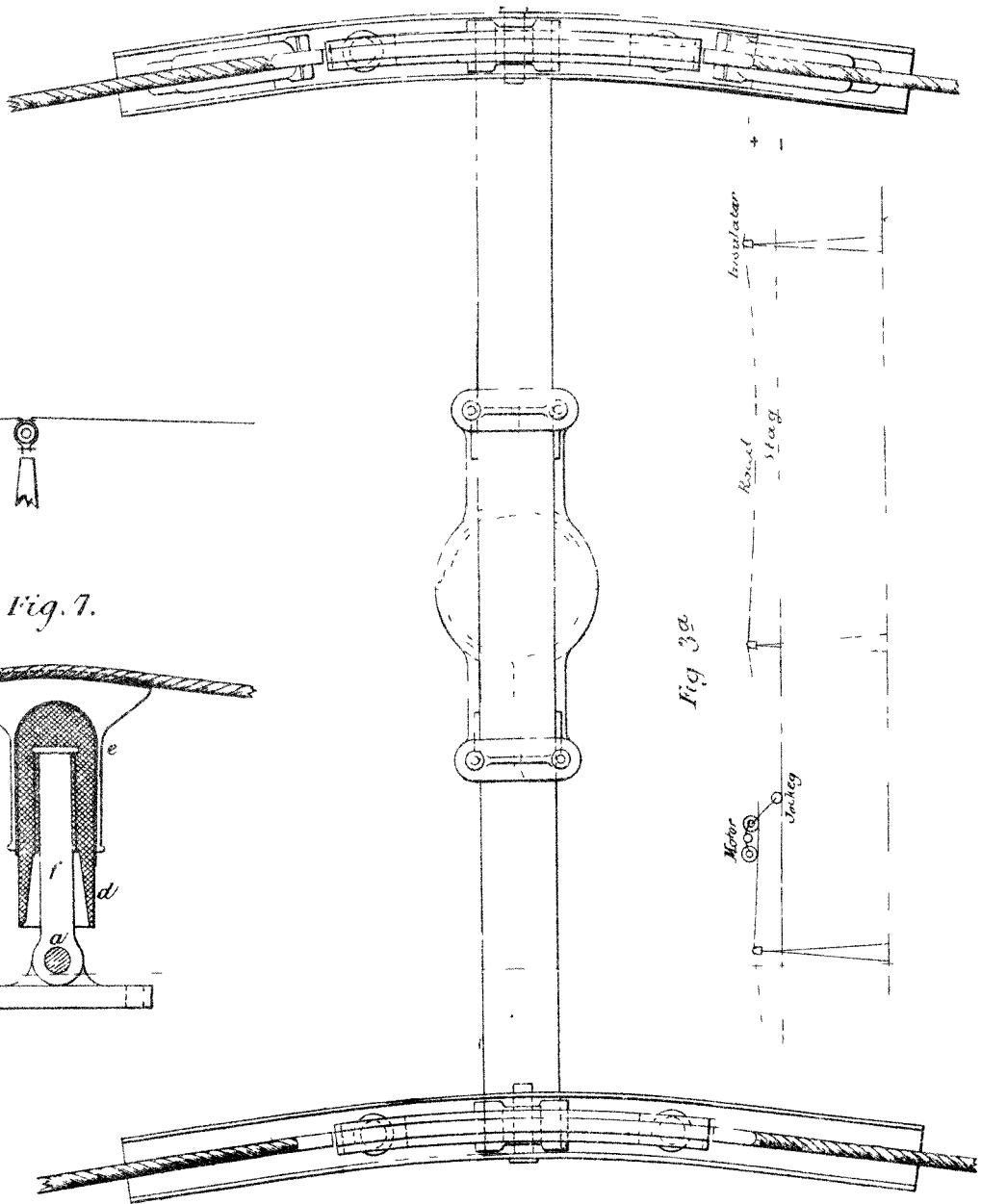


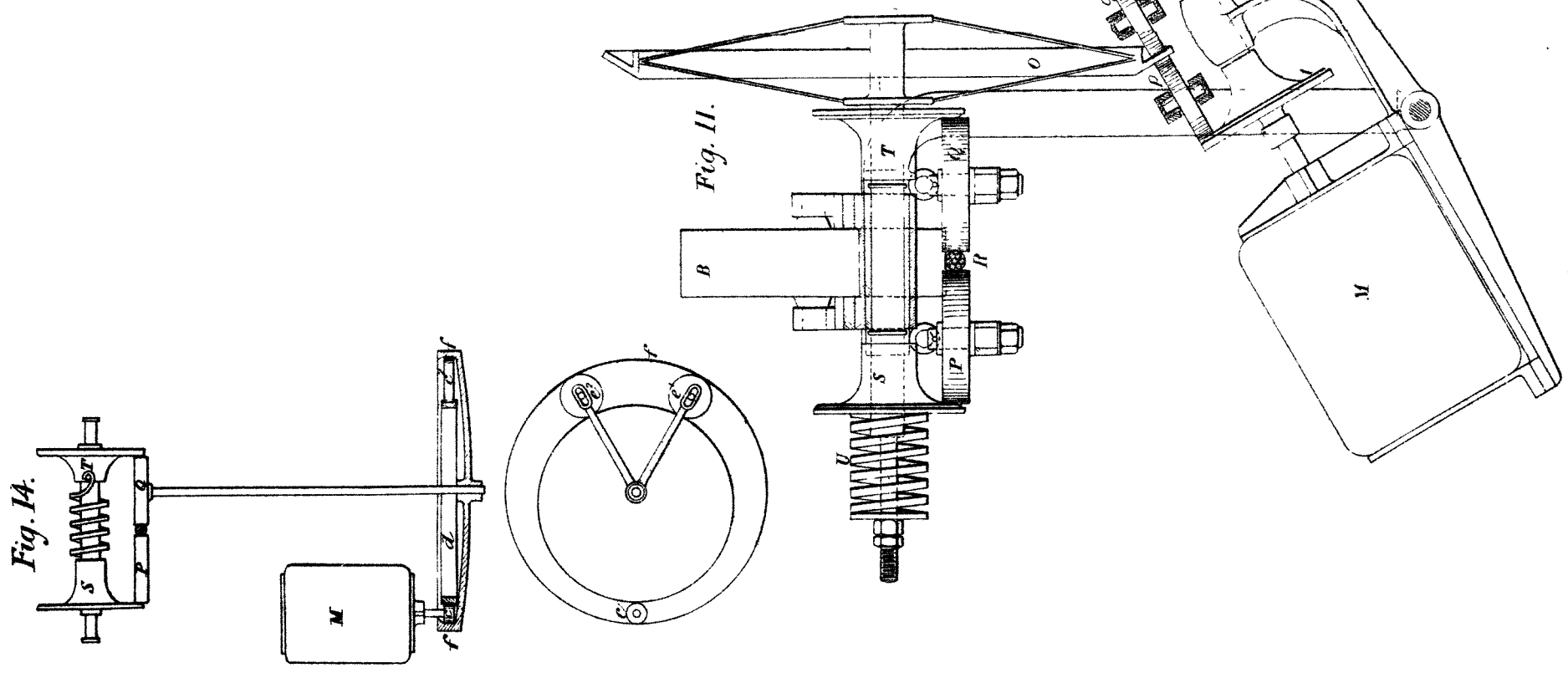
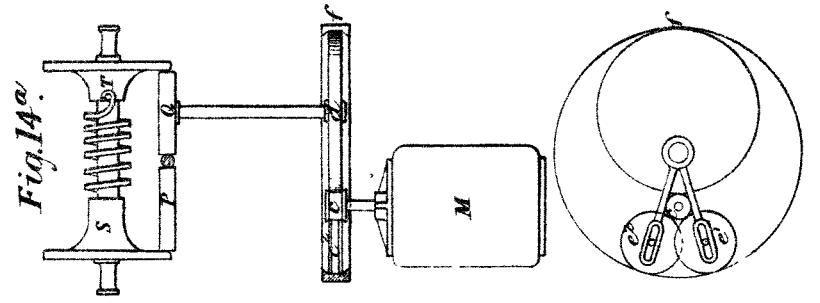
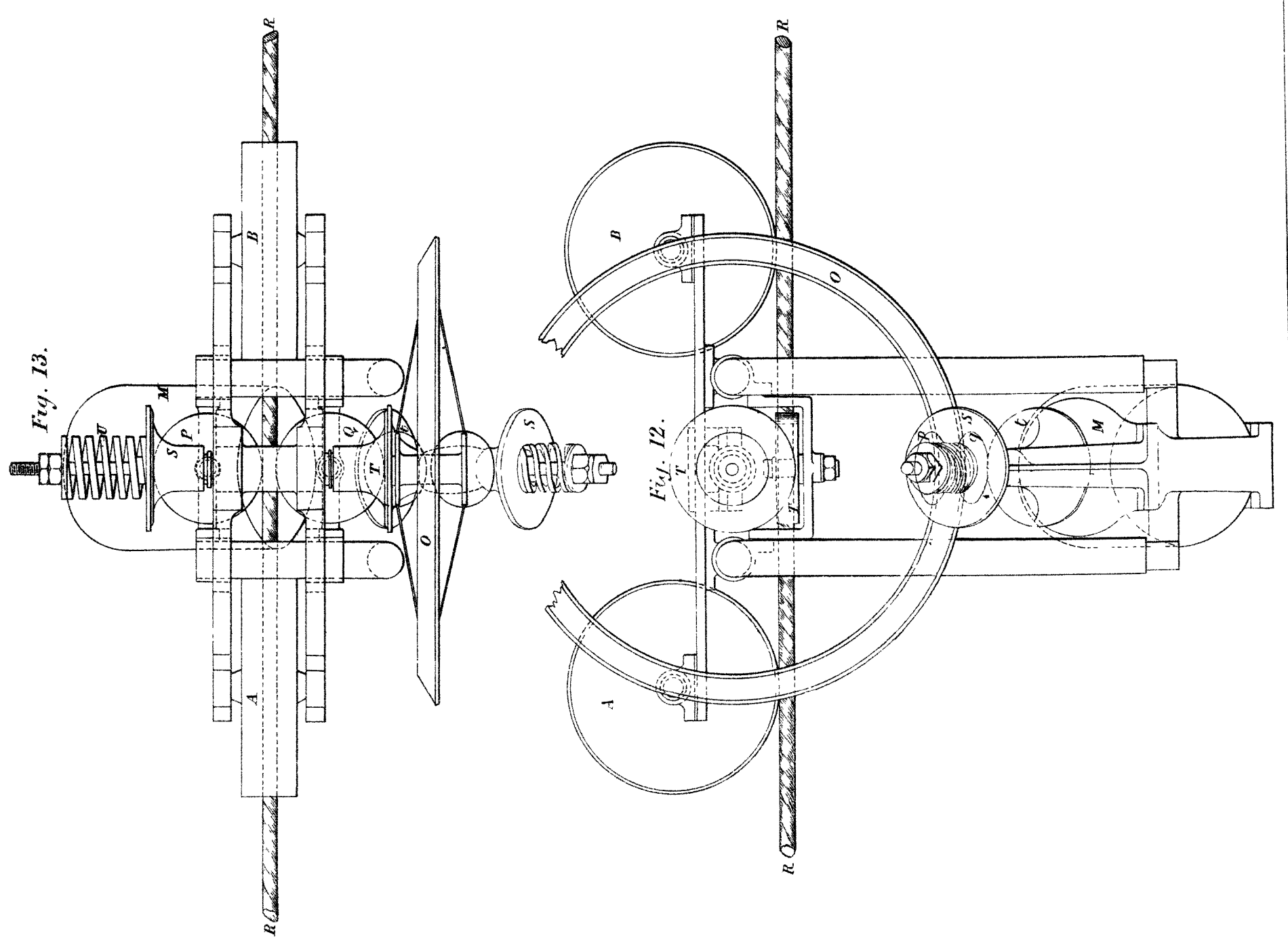
Fig 3a



This is the Sheet of Drawings marked B referred to in the annexed Letters of Registration granted to Fleming Jenkin, this fourth day of October A.D. 1885.

Augustus Loftus.

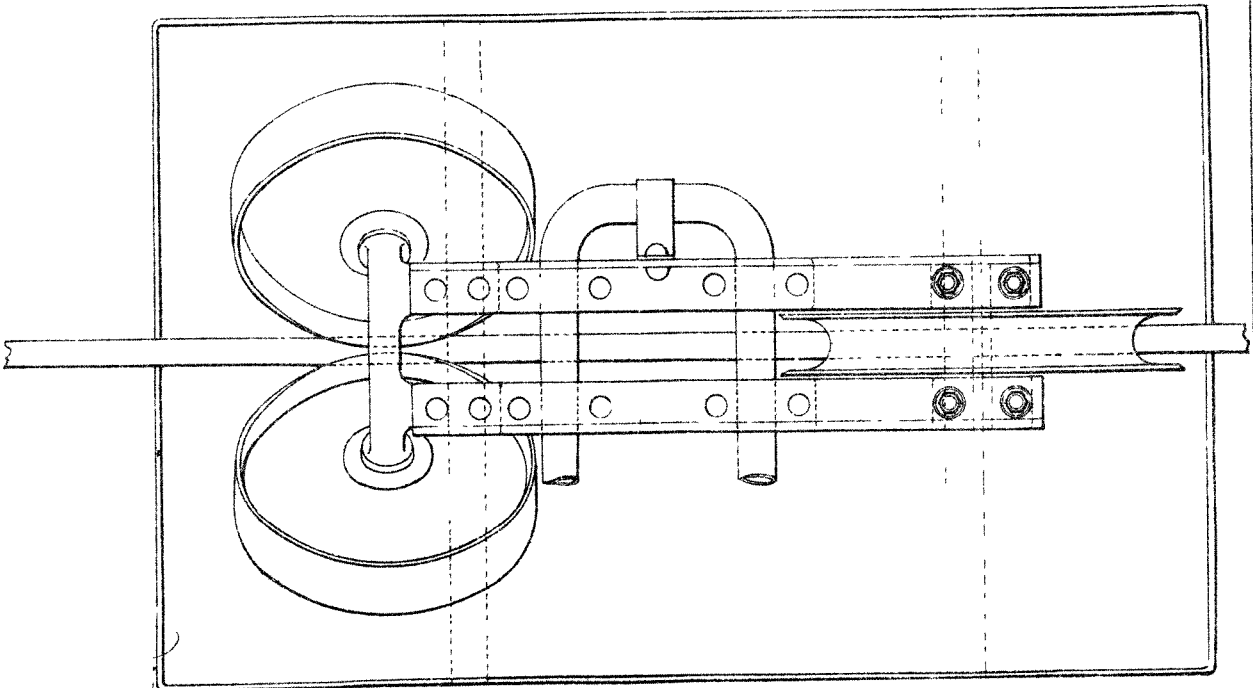
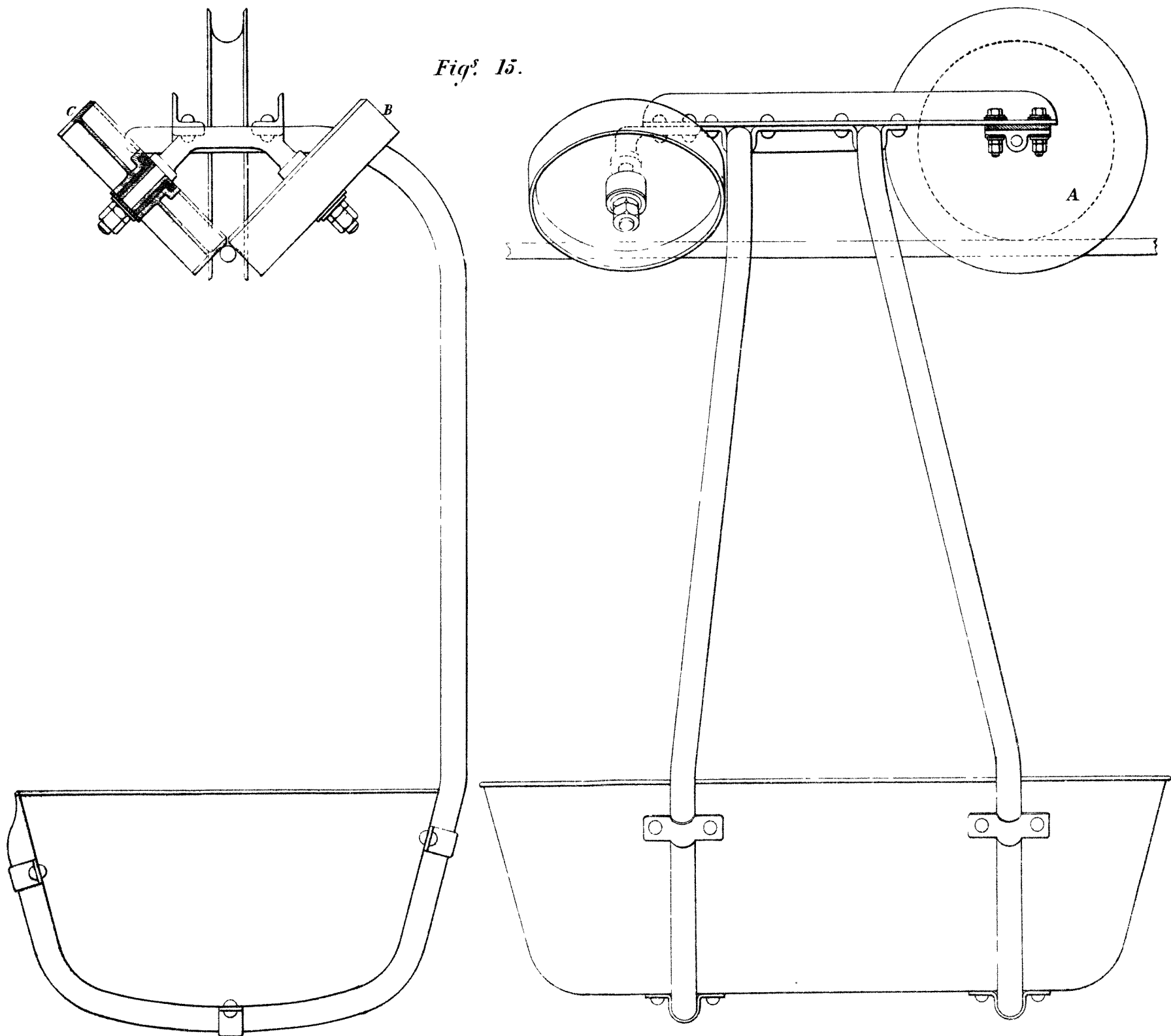
C



*This is the Sheet of Drawings marked C referred to in the annexed Letters of Registration granted to Fleming Jenkin, this fourth day of October A.D. 1885.*

*Augustus Loftus.*

D



*This is the Sheet of Drawings marked D referred to in the annexed  
 Letters of Registration granted to Fleming Jenkin, this fourth day  
 of October A.D. 1883.*

*Augustus Loftus.*

This is the Sheet of Drawings marked B referred to in the annexed Letters of Request, granted to Fleming Jenkin, this fourth day of October, A.D. 1883.  
Augustus Loftis.

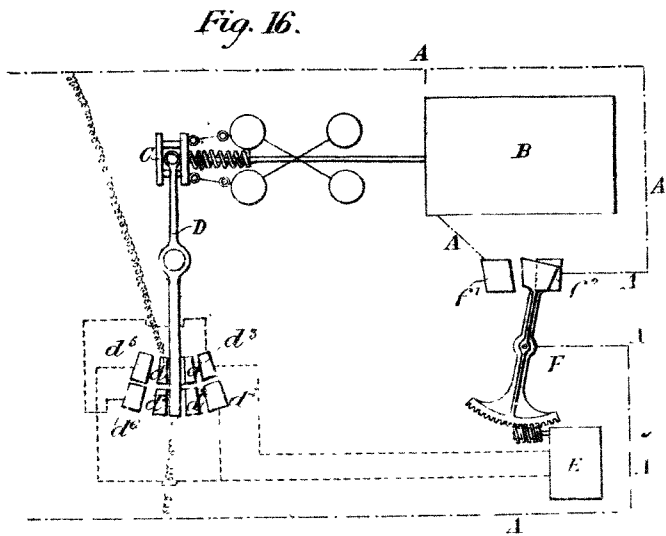


Fig. 16.

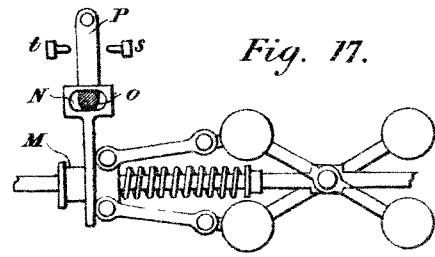


Fig. 17.

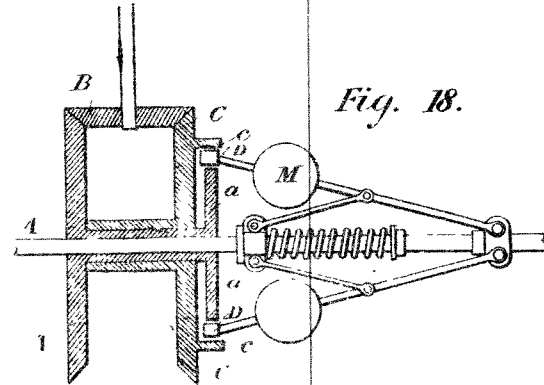


Fig. 18.

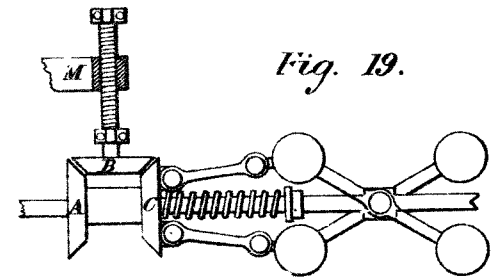


Fig. 19.

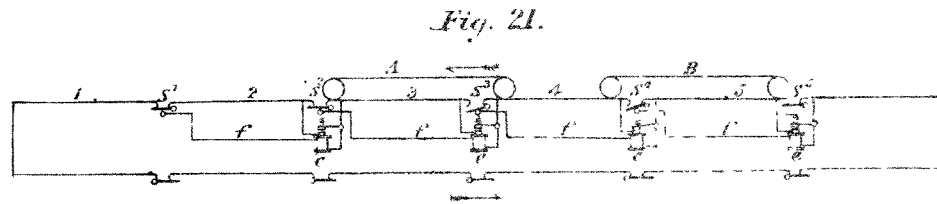


Fig. 21.

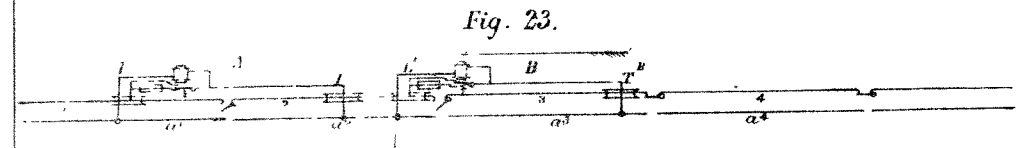


Fig. 23.

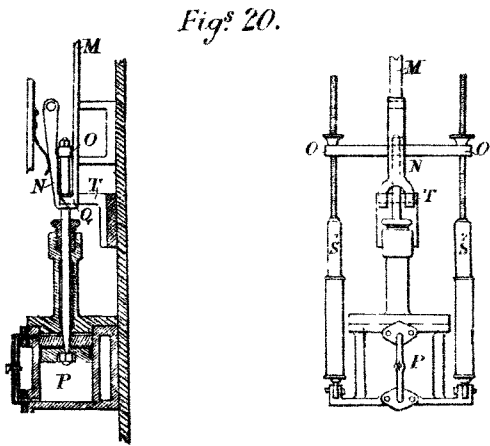


Fig. 20.

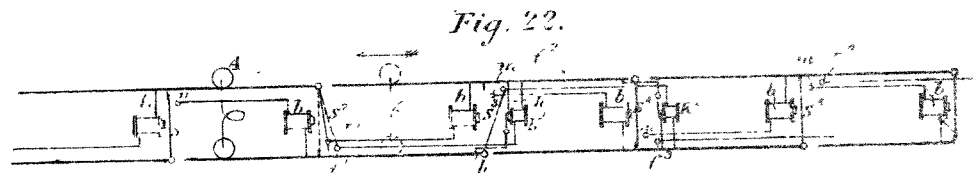


Fig. 22.

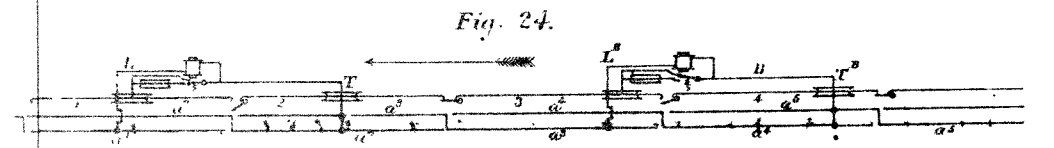


Fig. 24.

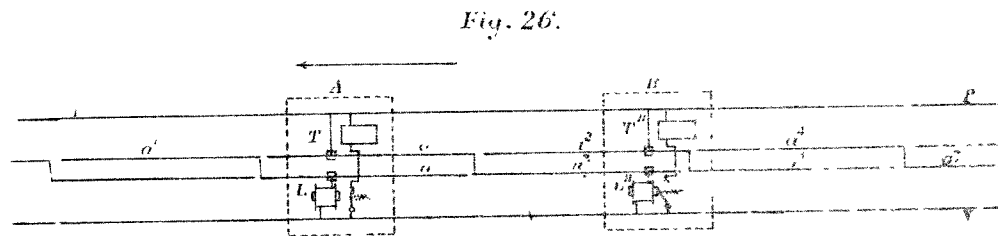


Fig. 26.

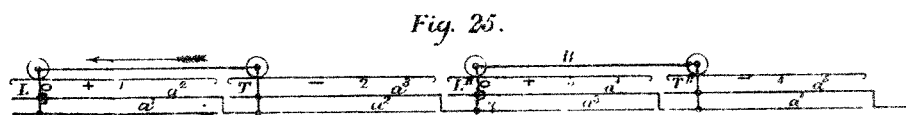


Fig. 25.

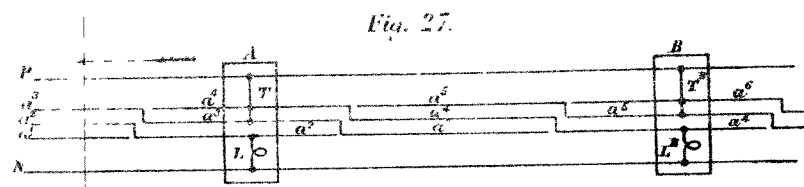


Fig. 27.



A.D. 1883, 11th October. No. 1321.

**AN INVENTION OR APPLICATION OF POLISHED METALLIC SUBSTANCES FOR  
THE EXCLUSION OF RADIANT HEAT.**

**LETTERS OF REGISTRATION** to Thomas Henry Feilding and Albert Nathan Jonsen, for an invention or application of Polished Metallic Substances for the Exclusion of Radiant Heat.

[Registered on the 13th day of October, 1883, in pursuance of the Act 16 Vic. No. 24.]

BY HIS EXCELLENCY THE RIGHT HONORABLE SIR AUGUSTUS WILLIAM FREDERICK SPENCER LOFTUS (commonly called LORD AUGUSTUS LOFTUS), Knight Grand Cross of the Most Honorable Order of the Bath, a Member of Her Majesty's Most Honorable Privy Council, Governor and Commander-in-Chief of the Colony of New South Wales and its Dependencies.

TO ALL TO WHOM THESE PRESENTS SHALL COME, greeting :

WHEREAS THOMAS HENRY FEILDING, of 15, Upper William-street, Sydney, artist, and ALBERT NATHAN JONSEN, of Haviland, Glebe Point, gentleman, have by their Petition humbly represented to me that they are the authors or designers of a certain invention or improvement in manufactures, that is to say, of an invention entitled "An Invention or Application of Polished Metallic Substances for the Exclusion of Radiant Heat," which is more particularly described in the specification which is hereunto annexed; and that they, the said Petitioners, have deposited with the Honorable the Treasurer of the said Colony of New South Wales the sum of Twenty Pounds sterling, for defraying the expense of granting these Letters of Registration, as required by the Act of Council, sixteenth Victoria, number twenty-four; and have humbly prayed that I would be pleased to grant Letters of Registration, whereby the exclusive enjoyment and advantage of the said invention or improvement might be secured to them for a period of fourteen years: And I, being willing to give encouragement to all inventions and improvements in the arts or manufactures which may be for the public good, and having received a report favourable to the prayer of the said Petition, from competent persons appointed by me to examine and consider the matters stated therein and to report thereon for my information, am pleased, with the advice of the Executive Council, and in exercise of the power and authority given to me by the said Act of Council, to grant, and do by these Letters of Registration grant unto the said Thomas Henry Feilding and Albert Nathan Jonsen, their executors, administrators, and assigns, the exclusive enjoyment and advantage of the said invention or improvement, for and during the term of fourteen years from the date hereof; to have, hold, and exercise unto the said Thomas Henry Feilding and Albert Nathan Jonsen, their executors, administrators, and assigns, the exclusive enjoyment and advantage thereof, for and during and unto the full end and term of fourteen years from the date of these presents next and immediately ensuing, and fully to be complete and ended: Provided always, that if the said Thomas Henry Feilding and Albert Nathan Jonsen shall not, within three days after the granting of these Letters of Registration, register the same in the proper office in the Supreme Court, at Sydney, in the said Colony of New South Wales, then these Letters of Registration, and all advantages whatsoever hereby granted, shall cease and become void.

In witness whereof, I have hereunto set my sign manual, and have caused the present Letters of Registration to be sealed with the seal of the said Colony of New South Wales, at Government House, Sydney, in New South Wales, this eleventh day of October, in the year of our Lord one thousand eight hundred and eighty-three.

[L.S.]

AUGUSTUS LOFTUS.



---

*An Invention or Application of Polished Metallic Substances, &c.*

---

TO ALL TO WHOM THESE PRESENTS SHALL COME: THOMAS HENRY FEILDING, of 15, Upper William-street, artist, and ALBERT NATHAN JONSEN, of Haviland, Glebe Point, gentleman, send greeting:

WHEREAS we are desirous of obtaining Letters of Registration for securing unto us Her Majesty's Special License that we, our executors, administrators, and assigns, and such other as we or they shall at any time agree with, and no other, shall and lawfully may from time to time, and at all times during the term of fourteen years, to be computed from the day on which this instrument shall be left at the office of the Minister of Justice, Sydney, make, use, offer, and vend within the Colony of New South Wales "An Invention or Application of Polished Metallic Substances for the Exclusion of Radiant Heat," as more particularly described in the following specification:—

SPECIFICATION.

THIS invention has been designed for the purpose of protecting houses, buildings, sheds, and every kind of premises, and also the human body and animals, as applied to clothing and coverings, from radiant heat, and for the protection of ships' bottoms from fouling, and the protection of timber against the ravages of the white ant (so called).

The invention of this new application consists of thin polished or bright metallic foil, or metallic leaf coatings or coverings, such as tinfoil, brought either into immediate contact with the surface to which it is desired that it should be applied, or fastened thereto by the means of any adhesive mixture, or deposited thereon from a solution which afterwards could be brightened by burnishing or otherwise.

The metallic substance or solution which we claim to use may be made of any metal, or of any alloy of or combination of metals.

The advantages are obvious from what is above stated, viz., perfect protection from radiant heat in every case in which the invention is applied sufficiently, preservation of timber from the ravages of the white ant, and prevention of fouling of ships' bottoms.

And we claim as our invention the use of such polished metallic coating applied and used in the manner substantially described and set forth in the above specification.

THOS. HY. FEILDING.  
ALBERT N. JONSEN.

2, Wentworth Court, Sydney, 21st August, 1883.

---

This is the specification referred to in the annexed Letters of Registration granted to Thomas Henry Feilding and Albert Nathan Jonsen, this 11th day of October, A.D. 1883.

AUGUSTUS LOFTUS.

---

REPORT.

---

Sir,

In the matter of the application of Messrs. Feilding and Jonsen for Letters of Registration for an invention consisting in the "Application of polished metallic substances for the exclusion of radiant heat," we have the honor to report that as the specification did not seem to us to be sufficiently explicit and guarded, we have conferred with the applicants, and obtained from them an amended specification, on which we think that Letters of Registration may be granted.

The cancelled and amended specifications are enclosed herewith.

The Under Secretary of Justice.

Sydney, 30 August, 1883.

We have, &c.,  
J. SMITH.  
CHAS. WATT.

---



A.D. 1883, 11th October. No. 1322.

IMPROVEMENTS IN THE MANUFACTURE OF INCANDESCENT ELECTRIC  
LAMPS, &c.

LETTERS OF REGISTRATION to Alfred Swan, for Improvements in the  
Manufacture or Construction of Incandescent Electric Lamps, and in Machinery  
and Apparatus employed therein, and in Holders for the said Lamps.

[Registered on the 13th day of October, 1883, in pursuance of Act 16 Vic. No. 24.]

BY HIS EXCELLENCY THE RIGHT HONORABLE SIR AUGUSTUS WILLIAM FREDERICK SPENCER LOFTUS  
(commonly called LORD AUGUSTUS LOFTUS), Knight Grand Cross of the Most Honorable Order of  
the Bath, a Member of Her Majesty's Most Honorable Privy Council, Governor and Commander-in-  
Chief of the Colony of New South Wales and its Dependencies.

TO ALL TO WHOM THESE PRESENTS SHALL COME, greeting :

WHEREAS ALFRED SWAN, of the borough of Gateshead, in the county of Durham and kingdom  
of England, engineer, hath by his Petition humbly represented to me that he is the author or designer of  
a certain invention or improvement in manufactures, that is to say, of an invention entitled "Improvements  
in the manufacture or construction of Incandescent Electric Lamps and in machinery or apparatus  
employed therein, and in Holders for the said Lamps," which is more particularly described in the  
specification hereunto annexed, marked A, and the four sheets of drawings relating thereto, marked B, C,  
D, and E respectively, and which are also hereunto annexed; and that he, the said Petitioner, hath  
deposited with the Honorable the Treasurer of the said Colony of New South Wales the sum of Twenty  
Pounds sterling, for defraying the expense of granting these Letters of Registration, as required by the  
Act of Council, sixteenth Victoria, number twenty-four; and hath humbly prayed that I would be pleased  
to grant Letters of Registration, whereby the exclusive enjoyment and advantage of the said invention or  
improvement might be secured to him for a period of fourteen years: And I, being willing to give encourage-  
ment to all inventions and improvements in the arts or manufactures which may be for the public good,  
and having received a report favourable to the prayer of the said Petition from competent persons appointed by  
me to examine and consider the matters stated therein and to report thereon for my information, am pleased,  
with the advice of the Executive Council, and in exercise of the power and authority given to me by the said Act of  
Council, to grant, and do by these Letters of Registration grant unto the said Alfred Swan, his executors,  
administrators, and assigns, the exclusive enjoyment and advantage of the said invention or improvement,  
for and during the term of fourteen years from the date hereof; to have, hold, and exercise unto the said  
Alfred Swan, his executors, administrators, and assigns, the exclusive enjoyment and advantage thereof,  
for and during and unto the full end and term of fourteen years from the date of these presents next and  
immediately ensuing, and fully to be complete and ended: Provided always, that if the said Alfred  
Swan shall not, within three days after the granting of these Letters of Registration, register the same  
in the proper office in the Supreme Court, at Sydney, in the said Colony of New South Wales, then  
these Letters of Registration, and all advantages whatsoever hereby granted, shall cease and become void.

In witness whereof, I have hereunto set my sign manual, and have caused the present Letters of  
Registration to be sealed with the seal of the said Colony of New South Wales, at Govern-  
ment House, Sydney, in New South Wales, this eleventh day of October, in the year of our  
Lord one thousand eight hundred and eighty-three.

[L.s.]

AUGUSTUS LOFTUS.

*Improvements in the Manufacture of Incandescent Electric Lamps, &c.*

A.

SPECIFICATION of ALFRED SWAN, of the borough of Gateshead, in the county of Durham and kingdom of England, engineer, for "Improvements in the manufacture or construction of Incandescent Electric Lamps, and in Machinery or Apparatus employed therein, and in Holders for the said Lamps."

MY invention has for its object the improvement and simplification of the means whereby the glass and wire portions of incandescent electric lamps are produced or combined. According to my said invention, I form the bulb by blowing and rotating the molten glass in a mould, or the mould may be rotated around the glass, or both the mould and the glass may be rotated. Such mould may be made of any suitable material, such, for example, as a compound of finely pulverized coke and plumbago mixed with tar into a paste, compacted into a solid mass by pressure, and by baking in a furnace to give it the desired hardness and stability. The desired shape is given to the mould either before or after baking. Or the mould may be made in a similar manner of plumbago, coke, or other suitable form of carbon, mixed with moist clay, or with such clay and tar combined, or with other suitable cementing material. Two parts of pulverized coke to one part of pulverized plumbago or graphite, with just sufficient tar, or moist clay, or both, to bring the mass to the consistency of a stiff paste, answer well in practice, but I do not limit myself thereto. Or it may be formed from steatite or soapstone, formed to a shape corresponding to the article to be produced. The moulds are preferably formed in halves, enclosed in hinged wooden boxes or other protecting cases, and are provided with a "get" or aperture through which the molten glass on the blow-pipe or blowing iron is introduced. The said blow-pipe, or the mould, or both the blow-pipe and the mould, are rotated (by any suitable means) whereby the glass is blown very truly and free from mould marks. I do not limit myself to any particular construction of mould, nor to the material of which it is made, provided that it has the form and qualities necessary to produce the bulbs of incandescent electric lamps.

This mould may be formed so as to produce the bulbs without mould marks, or with but little mould marks, as follows:—Figure 01 is a side elevation of a mould in its closed portion, constructed according to this part of my invention. Figure 02 is an elevation of the said mould, showing one of the top parts opened out and the bottom part in section. Figure 03 is a plan showing the top parts fully open and clear of the bottom part.

The mould is made in three parts,  $A^2 A^3$ , the bottom part  $A$  being in one piece, and the top parts  $A^2 A^3$  are connected thereto by a hinge-pin,  $B$ , passing through lugs,  $a$ , formed on the said top parts, which are each provided with a handle,  $C$ , so as to facilitate their being closed over the lower part,  $A$ , and opened out therefrom. The outer part or casing  $D$  of the mould may be of metal or wood, whilst the inner part  $E$ , for imparting to the article to be moulded the desired form, may consist of any suitable material, but it is preferred to employ plumbago, or carbon agglomerate, or steatite, or soapstone for the purpose.

The upper surface of the lower portion  $A$  of the mould has an inclined surface, as shown, and the under surface of each of the top parts  $A^2 A^3$  are similarly inclined, so that when the mould is closed, as shown in figure 01, the line of division between the bottom part  $A$  and the two top parts  $A^2 A^3$  will be at an angle to the base of the mould, and at an angle other than a right angle to the axis of rotation of the article being moulded. The article to be moulded is produced by blowing the glass into the mould in its closed position and rotating it at the same time in the mould, which may be effected in the usual manner; but by constructing the mould in the manner described it is obvious that by reason of the bottom part of the mould being in one piece, and the junction of the mould being inclined to the axis of rotation, the moulded article will be free, or nearly free, from mould marks. The bulbs thus formed are intended to be exhausted of air through an opening left for the purpose in the stem or filling piece which contains the terminal wires.

Figure 1 of the accompanying drawings represents in plan, and figure 2 in front elevation, an apparatus, constructed according to my invention, for bending into a U shape the terminal wires by which the carbon filament is to be held in the lamp. The said apparatus consists of a bed-plate,  $a$ , having at one end a stop,  $b$ , and at the other end a cutter lever,  $c$ , affixed to a spindle,  $d$ , as a centre, the said spindle extending along the side of the bed-plate  $a$ , and turning on lugs,  $e$ , thereon. Affixed to the said spindle  $d$ , half-way between the cutter lever  $c$  and the stop  $b$ , is a cylindrical rod,  $f$ , whose length is situated at right angles to the spindle  $d$ . The bed-plate  $a$  is furnished with rests  $g$ , into which the wire (figure 3), to be cut and bent, is placed, when the cutter lever  $c$  is in the raised position, represented in figure 2, one end of the wire abutting against the stop  $b$  and the other end passing beneath the cutter lever  $c$ . On depressing the said cutter lever  $c$ , the said wire is cut to the proper length, and the cylindrical piece  $f$  at the same time descends into the semi-cylindrical recess  $a^2$  in the bed-plate  $a$ , and thereby bends the wire at its centre and forms it into a U shape, as indicated in dotted lines in figure 2. Figure 4 shows the bent wire removed from the apparatus.

The apparatus may be formed to act and bend wire of but one thickness and length, or wires of two or more different thicknesses and lengths, or to form loops of different widths and shapes. The drawing represents an apparatus adapted for cutting and bending wires of three different thicknesses, the cylindrical piece  $f$  being made with portions of three different diameters, with corresponding rests,  $g$ , to accommodate the three different thicknesses of wire. The cutter and the stop may be made to slide on a spindle, and thus be adapted to cut various lengths of wire.

Figure 5 represents in plan, and figure 6 in side elevation, an apparatus, constructed according to my invention, for coiling the ends of the terminal wires into eyes or loops for fixing the bulb of the lamp to its holder. Figure 7 is an enlarged plan of a part of the same. Upon a bed-plate,  $h$ , I fix a stop-piece,  $h^2$ , of the form shown, and a button,  $h^3$ , which may be provided with a head or a spring catch, as shown at  $h^4$ , to retain the wire loop in position. In a framing,  $i$ , beneath the bed-plate  $h$ , are carried spindles,  $i^1 i^2 i^3 i^4$ , furnished with gearing wheels for transmitting motion to both of the spindles  $i^2 i^3$ , when the button in the spindle  $i^1$  is rotated. The spindles  $i^2$  and  $i^3$  project above the bed-plate  $h$ , as shown on either side of the end of the stop-piece  $h^2$ , the distance between the axis of the said spindles being equal to that required between the centres of the loops to be made in the wire. The projecting ends of the spindles

*Improvements in the Manufacture of Incandescent Electric Lamps, &c.*

spindles  $i^2$   $i^3$  are formed with slits or recesses, which may be made either by cutting them in the substance of the projecting ends of the spindles, or by pins,  $i^1$ , attached to the spindles and placed near to the said projecting ends thereof, as shown. The wire bent into the U form, shown in figure 4, is placed around the button  $h^3$ , with its legs or side pieces lying along the sides of the stop  $h^2$ , and the two ends of the said wire are placed in the slits or recesses in the projecting ends of the spindles  $i^2$   $i^3$ , as shown in full lines in figure 7. On partially rotating the spindle  $i^1$  by means of the button thereon the gearing wheels cause also the spindles  $i^2$   $i^3$  to partially rotate until prevented from further rotating by the stop  $h^2$ , so that the spindles  $i^2$   $i^3$  are brought into the position shown in dotted lines in figure 7, and by this partial rotation (as the ends of the wire are confined in the slits or recesses in the ends of the said spindles) the said ends of the wire are bent into a loop form, as shown in dotted lines in figure 7, and also in figure 9, which represents a bent wire removed from the apparatus, short tags or ends being formed as at  $j^1$ , which tags or ends serve to effect the secure attachment of the loops to the glass when they are subsequently embedded therein. It will be seen that the button  $h^3$  and stop  $h^2$  may be in one place, if desired, or may be arranged to slide and to be capable of adjustment to different lengths of wire.

I form the stem of the lamp by placing molten glass enamel, or other suitable material, in a mould in which the conducting wires, with or without loops already formed thereon, are placed and held in their proper position; and I so arrange the wires that on pressing the two portions of the mould together, and forcing molten glass thereinto under pressure, the wires are firmly embedded in the glass. This mould is so constructed that a flange or cup of glass is formed on the stem near the terminal loops or protruding wires, the size and shape of which flange or cup exactly correspond to that of an aperture left in the neck of the bulb. The edges of the two parts, that is the neck of the bulb and the flange or cup of the stem, are joined by fusion. Figure 10 represents opened out a mould, constructed according to my invention, for casting the stems, as hereinbefore described, and figure 11 is a plan of the same closed. The said mould is formed in halves,  $k$   $k^1$ , hinged together, each half being provided with handles for opening and closing the same. The said mould is formed with an opening or "get,"  $l$ , leading into a portion of the mould at  $l^1$ , in which the flange of the stem is formed; this portion,  $l^1$ , of the mould opening into the portion  $l^2$ , in which the stem proper is formed. At  $m$  are two projections for receiving the eyes of the terminal wires to be embedded in the stem during the process of casting the said stem, the said projections, when the mould is closed, fitting into corresponding recesses in the other half of the mould. In figure 10 a loop of wire is shown in position, pieces at  $l^3$  forming a filling for the bottom of the portion  $l^2$  of the mould. The terminal wire being placed in position, as in figure 10, the mould is closed and molten glass (or enamel or other material of which the stem is to be formed) is introduced into the mould by the "get"  $l$ , and is pressed by means of a plug, worked by a lever or otherwise, into the portions  $l^1$  and  $l^2$ , the wires being enveloped or embedded in the said stem, the tags  $j^1$  of the wires giving a very firm hold of the wires in the glass or material of the stem. Figure 12 represents a stem cast in this mould. Figure 13 represents a mould for casting cup-like flanges upon the stem, as shown in figure 14. The mould is formed in hinged parts and with a "get"  $l$ , as in the mould hereinbefore described, but the portion  $l^1$  is cup-shaped, and the portion  $l^2$  is formed as a core-piece,  $l^4$ , capable of being slid into and from the mould, the inner end of the core-piece  $l^4$  and the portion  $l^1$  of the mould giving between them the necessary shape to the cupped flange of the stem. To enable the wire to be inserted the core-piece  $l^4$  may be made in halves. The terminal wires pass through a slit between the closing pieces  $l^3$ , as shown in figure 13. It will readily be seen that when the mould is closed, and the molten glass or other material is introduced into the "get"  $l$ , the said glass or material will flow, under pressure, into the cup-shaped recess at  $l^1$  and thence into the portion  $l^2$  in the core-piece  $l^4$ , the wires becoming embedded in the said material. By means of the lever  $n$  the core-piece  $l^4$  is raised from the mould immediately after casting to prevent risk of fracture of the stem. Figure 14 represents a cup-flanged stem produced in this mould.

In order to give a more complete adhesion between the glass or the like and the terminal wires, which pass through the said glass, or the like to the carbon filament, and prevent the formation of air bubbles along the track of the wires, I pass an electric current through the wires at the same time that the glass or the like is being pressed around them. I may insulate portions of the metal of the said mould so as to lead the current wires up to and through the wires which are to be embedded in the stem.

Figure 14<sup>A</sup> represents an opened-out mould, constructed with an insulating portion for the purpose of carrying my invention into effect, and figure 14<sup>B</sup> is a transverse section on the line 1 2, figure 14<sup>A</sup>. The part marked  $a$  (in which the recesses in which the glass is cast are made) is of a non-conducting material or comparatively non-conducting material;  $b$  are studs, pins, or pegs, on one half of the mould over which the loops of the terminal wire pass, the said wire being also passed over a stud-pin or peg,  $c$ , formed upon a plate,  $c^2$ , secured or otherwise secured to the material  $a$ . The pegs  $b$  are carried to the exterior of the casing of the mould, being surrounded by the material  $a$ , as shown in figure 14<sup>B</sup>, and there terminating in contact-plates  $b^2$ . When the wire is placed in position, as shown in figure 14<sup>A</sup>, the pegs  $b$  are brought into contact with a battery or other source of electricity, which may conveniently be effected by causing the contact-plates  $b^2$  to come into contact with other plates in the "press" or receiver in which the mould is held during the casting of the glass therein, the last-named plates being in metallic connection with the positive and negative wires of the source of electricity.

Thus when the mould is put in place a current of electricity is passed through the terminal wire at the same time that the glass is pressed around it, whereby a very complete adhesion of the glass to the wires is obtained;  $d$  are pegs for retaining the wires in proper position. Figure 14<sup>C</sup> represents an opened out mould wherein the pegs  $b$ , in the one half of the mould, and the recesses  $b^2$ , in the other half, into which the said pegs fit when the mould is closed, are surrounded by insulating material, as shown at  $a^2$ . Figures 14<sup>D</sup> is a section on the line 3 4, figure 14<sup>C</sup>. The pegs  $b$  are continued to the exterior of the mould for connection to the source of electricity, as hereinbefore described. I do not limit myself to any particular form of the moulds, nor of the recesses therein for the reception of the glass, and the said moulds may be constructed of any suitable material, provided that insulation is provided for the purpose of directing an electrical current through the wire during the casting of the glass. The mould here shown is one to produce a stem or filling-piece, having a hole in it through which the exhaustion of the bulb is to be effected.

It

*Improvements in the Manufacture of Incandescent Electric Lamps, &c.*

It will be understood that the wires may be cast in the stem before the eyes are formed in the said wires; but I prefer to cast them after the said eyes have been formed, as then the tags  $j^1$  are firmly embedded in the glass or the like, and a secure attachment is thus made.

I form the ends of the terminal wires into sockets, for the reception of the carbons, by flattening the said ends, and then coiling the flattened ends into the required sockets.

Figure 15 is a front view, and figure 16 is an elevation, of the press for flattening out the ends of the wires to be afterwards coiled.

The cam-like rollers  $p p$  are mounted in a framing,  $p^1$ , and are geared together by toothed gearing at  $p^2$ , and one of them is provided with a handle,  $p^3$ , for turning the rollers. The opposed pressing faces of the said cam rollers  $p p$  are cut away to allow of the introduction to their full extent and thickness of the portions of wire projecting beyond the stem of glass or the like. The said cam rollers  $p p$ , owing to their shape at the parts extending from the point at which they begin to act upon the wire (the position shown in figure 16) to the part at which the flattening takes place, gradually grip upon and gradually flatten out the ends of the wires inserted between them, thus avoiding the weakness resulting from a sudden transition from thick to thin. The looped form of the wire embedded in the glass after leaving the mould is represented on an enlarged scale at figure 17, while figure 17<sup>A</sup> shows the wire loop cut or severed ready for being passed between the before-described cam-pressing rollers. The ends of the flattened-out blades (which are shown in figure 18) are then cut off by means of a cutting press of any convenient form to an angle which determines or is determined by the pitch of the spiral to be produced. Figure 19 represents a wire end thus flattened out and cut, and also bent outwards.

Figure 20 represents, in sectional elevation, an apparatus, constructed according to my invention, for coiling the flattened-out ends of the wires into sockets for the reception of the carbon filament, and figure 21 is an end view of the same. In a tubular piece,  $q$ , carried by the standard  $q^2$ , is mounted a spindle or mandrel,  $r$ , capable of being rotated in the said tubular piece  $q$  by means of the handle  $r^2$ . The said spindle  $r$  has projecting from its end a needle  $r^3$ , of the size and shape (tubular, flat or other shape) of the carbon to be inserted in the coiled ends of the terminal wires. A clip-piece,  $s$ , is centred at  $s^2$  to the spindle  $r$ , being furnished with a tail-piece,  $s^3$ , engaging behind the flange  $q^3$  of the tubular-piece  $q$ , the spindle  $r$  being forced back by the spring  $t$ , the end of the said catch-piece  $s$  presses upon the root end of the needle  $r^3$ . By pressing forward the spindle  $r$  against the spring  $t$  the catch  $s$  is lifted off the needle  $r^3$ , owing to its tail-piece  $s^3$  being retained behind the flange  $q^3$ , and the tip of the end of the wire to be coiled (flattened and cut as hereinbefore described) is placed upon the needle  $r^3$ , so that when the spindle  $r$  is released and again forced back by the spring  $t$  the clip-piece  $f$  pinches the said tip of the flattened end of the wire down upon the needle. On rotating the spindle  $r$  by the handle  $r^2$ , and keeping the flattened end of the wire at the requisite angle to the said needle, the said flattened end is coiled upon the needle into a tubular or other form suitable for the reception of the ends of the carbon filament. I may attach to the stand of the apparatus an adjustable arm upon an upright support, and with a slot in it which, when the arm is in its proper position, acts as a guide to the wire whilst it is being coiled round the needle.

I prefer to act upon the wires in this apparatus when they are embedded in the glass stem, as shown in figure 22 (which represents the wires as having been coiled by the apparatus). The apparatus may be provided with a surface upon which to rest the said stem whilst the apparatus is operating.

Figure 23 shows a modification wherein the spring  $t$  is dispensed with, and the catch  $s$  is provided with a thumb-piece  $s^4$  to be depressed against the spring  $s^5$  for raising the tip of the catch-piece  $s$  from the needle  $r^3$ . In this modification I have also shown the spindle  $r$  as being provided with a screw thread,  $v$ , working in a screw in the tubular piece  $q$ , the number of turns of the screw corresponding with the number of coils to be given to the ends of the wires so as to prevent overwinding. In this modification I have also shown the fore end of the spindle  $r$  as being tapped to receive a stock-piece or nipple in which the needle is mounted. Needles when broken can then be readily replaced, or a fresh stock-piece carrying a needle of any desired size or shape can be introduced.

The junction of the wires and carbons may be completed by deposition of carbon in the ordinary manner.

My invention further relates to a holder for incandescent electric lamps, which will give a firm support for the same and allow of the ready detachment of either the bulb from the part which directly holds it, or of both the bulb and the said part together, from the bracket support or electrolier. At the same time also, if desired, the said holder will answer the purpose of a tap for the lamp. Figure 24 represents a holder constructed according to my invention and affixed to a bracket. Figure 25 is a vertical section of the same. The part A, which directly holds the bulb, is carried by a part, B, affixed to the end of the bracket or the like. The bulb is separable from the part A, or the said bulb and the part A can be removed from the part B together, without removing the bulb from the part A, as hereinafter described. Figures 26 and 27 are views of the part A taken at right angles to each other. Figure 28 is a plan of under side, the part A, with the cap-piece  $a^6$  removed, and figure 29 is a section on the line 1 2, figure 2, showing the part B in plan of under side and the part A in section engaged therewith. Figure 30 is a modification of the part A, as hereinafter described. The part A is made of non-conducting material, and contains two pairs of jaws,  $a a^2$ . The parts  $a$  of the said jaws are led through the part A, and are in metallic connection (through the springs  $b$  in the part B) with the current wires  $c$ , as shown clearly in figure 25. The other parts  $a^2$  are capable of being pressed away from the parts  $a$  by means of a pusher,  $d$ , the springs  $e$  causing the jaws  $a a^2$ , when pressure is released from the pusher  $d$ , to close firmly upon each other. One of the parts of each pair of jaws is preferably furnished with a pin,  $a^3$ , which enters a recess in the other part of the jaw. The cup part  $a^4$  of the part A is formed (as shown, for example, in figure 25) to correspond with and fit the end of the bulb. The attachment of the bulb to the part A is effected by pressing the pusher  $d$  so as to cause the jaws  $a a^2$  to open when the loops of the terminal wires are passed over the pins  $a^3$ , and on releasing the pusher  $d$  the jaws are acted upon by the springs  $e$  so that they close together and grasp the terminal loops between them and firmly retain the bulb in place in the said holder. By pressing upon the pusher  $d$  the jaws are opened, and the bulb can readily be removed from the part A. Figure 30 shows a modification (with the jaws open) wherein the thumb-piece  $d$ , to which is attached the back parts  $a$  of the jaws, bears against the piece  $e^3$ , which in its turn

*Improvements in the Manufacture of Incandescent Electric Lamps, &c.*

turn bears upon a spring,  $e^2$ , in the form of a blade, which may be held in its position by a projection at the middle, fitting into a corresponding depression in the bed-piece. The attachment of the part A to the part B is effected by means of the springs  $b$ , which are undercut or formed with projecting parts  $b^2$  at their ends, as shown in figures 25 and 29, and the said springs are also formed with recesses for containing the metallic-conducting parts of the part A, which conducting parts may be formed by continuations of the parts  $a$  of the jaws, as shown in figures 25 and 29. The upper portion of the part A is formed, as shown in figure 29, with shoulders or ledges  $a^5$  at opposite sides, and the part B is formed with a recess to receive this upper portion of the part A, the projections  $b^2$  of the springs  $b$  projecting into the said recess. The part A, when in position, at right angles to that shown in figures 25 and 29, is passed into the recess in the part B, and then by turning the said part A through a portion of a rotation the shoulders  $a^5$  engage with the projections  $b^2$  of the springs  $b$ , the upper parts of the pins  $a$  engaging with the recesses in the said projections of the springs  $b$ , thus making a metallic circuit between the conducting wires to and from the lamp. By giving the part A a motion of partial rotation the pins  $a$  will pass from contact with the projections of the springs  $b$ , and when brought to a position at right angles to that shown in figures 25 and 29 the said part A, together with the bulb, can be readily removed from the part B. If an intermediate position be given to the part A in the part B, the pins  $a$  may be brought out of contact with the projections  $b^2$  of the springs  $b$ , and thus the lamp be extinguished whilst the ledges  $a^5$  are still engaged with the said projections of the springs and the part A and the bulb are still held to the bracket. The non-conducting parts of the parts A and B may be made by moulding in glass or other material, and the conducting or metal parts may be produced by stamping, whereby the entire apparatus may be produced at a small cost, but I do not limit myself to any particular material or process of manufacture, provided that the conducting parts are properly insulated. It will be evident that the lamp-holder can also be used to support the lamp in the reverse or any other position from that shown in the drawing.

## CLAIMS.

- First—Producing bulbs or globes for incandescent electric lamps by blowing in moulds with rotation, as hereinbefore described.
- Second—The mould for moulding or shaping bulbs or globes for incandescent electric lamps or other articles of glass, the said mould being constructed with a bottom part in one piece, and with an inclined upper surface and with separate top parts similarly inclined on their under surface; substantially as hereinbefore described and illustrated in figures 01, 02, and 03 of the accompanying drawings.
- Third—In moulds for moulding or shaping bulbs for incandescent electric lamps or other articles of glass, the combination of a bottom part in one piece with divided top parts capable of being closed over the bottom part to complete the mould, and opened out therefrom to release the moulded article, substantially as hereinbefore described with reference to figures 01, 02, and 03 of the accompanying drawings.
- Fourth—In apparatus for bending wires for incandescent electric lamps, the combination of the recessed bed-plate  $a$  and bending-piece  $f$ , adapted for bending wire of one thickness and length, or wires of different thicknesses and different lengths, and forming loops of the same or different widths or shapes, substantially as described and illustrated in figures 1 and 2 of the accompanying drawings.
- Fifth—In apparatus for bending wires for incandescent electric lamps, the combination of a cutter-lever  $c$  and bending-piece  $f$ , suited for bending wire of one thickness or length, or wires of different thicknesses and different lengths, and forming loops of the same, or different widths or shapes, the said parts operating together upon a recessed bed-plate,  $a$ , substantially as described and illustrated in figures 1 and 2 of the accompanying drawings.
- Sixth—In apparatus for bending wires for incandescent electric lamps, the combination of the cutter-lever  $c$  and bending-piece  $f$  with a recessed bed-plate and a stop,  $b$ , to effect the cutting and bending of wire of one thickness and length or wires of different thicknesses and different lengths and forming loops of the same or different widths or shapes, substantially as described and illustrated in the said figures 1 and 2.
- Seventh—In apparatus for bending wires for incandescent electric lamps, the combination of the cutter-lever  $c$ , bending-piece  $f$ , spindle  $d$ , recessed bed-plate  $a$ , rests  $g$ , and stop  $b$ , for cutting and bending wire of one thickness and length, or wires of different thicknesses and different lengths, and forming loops of the same or different width or shapes, substantially as described and illustrated in the said figures 1 and 2.
- Eighth—The hereinbefore described apparatus for forming loops or eyes in the terminal wires for incandescent electric lamps, the essential feature of which apparatus is the combination of the rotating spindles  $i^2$   $i^3$  (recessed or slotted or otherwise formed for the reception of the ends of the wire to be bent into loops or eyes) with the stop  $h^2$  (or stops  $h^2$   $h^3$ ), substantially as hereinbefore described and illustrated in figures 5, 6, and 7 of the accompanying drawings.
- Ninth—Forming stems for the bulbs or globes of incandescent electric lamps, and embedding wires (with or without terminal loops formed thereon) in them by pressure in a mould, substantially as hereinbefore described.
- Tenth—The moulds for forming stems for the bulbs or globes of incandescent electric lamps, and securing the terminal wires therein, substantially as described and illustrated in figures 10, 11, and 13 of the accompanying drawings.
- Eleventh—The improvements in incandescent electric lamps, consisting in passing an electric current through the wire whilst the glass or the like is being pressed or formed around it, substantially as hereinbefore described.

Twelfth

*Improvements in the Manufacture of Incandescent Electric Lamps, &c.*

Twelfth—In the manufacture of incandescent electric lamps, the employment of a mould for forming the glass portions through which the terminal wires pass, the said moulds being formed or provided with insulating material to direct an electrical current through the wires whilst the glass is being pressed or formed around them, substantially as hereinbefore described with reference to figures 14<sup>A</sup> to 14<sup>P</sup> of the accompanying drawings.

Thirteenth—The apparatus for flattening the terminal wires of incandescent electric lamps, consisting of the combination of the cam rollers *p p*, formed as described with means for actuating them, substantially as and for the purpose described and illustrated in figures 15 and 16 of the accompanying drawings.

Fourteenth—Forming the ends of wires into sockets for the reception of the carbon filament of incandescent electric lamps by coiling or twisting the flattened ends of the wire, as hereinbefore described.

Fifteenth—The apparatus for coiling or twisting the ends of wires of incandescent electric lamps into flat cylindrical or other sockets for the reception of the carbon filament, the said apparatus consisting in the combination of the spindle *r* carried in a support and provided with means for rotating it, and also with a catch-piece, *s*, for retaining and releasing the wire, substantially as described and illustrated in figures 20, 21, and 23 of the accompanying drawings.

Sixteenth—The holder for incandescent electric lamps, consisting of a part, A, which directly holds the bulb together with a part, B, which holds the part, A, the said parts A and B being provided with fastening devices so that the bulb can be removed from the part A, or the part A and the bulb be removed together from the part B, substantially as hereinbefore described and illustrated in figures 24 to 30 of the accompanying drawings.

Seventeenth—In incandescent electric lamp-holders, the combinations of the jaws *a a*<sup>2</sup>, push-piece *d*, and springs or spring (*e* or *e*<sup>2</sup>) for attaching the bulb to and releasing it from the holder, substantially as hereinbefore described and illustrated in figures 24 to 30 of the accompanying drawings.

Eighteenth—In incandescent electric lamp-holders, the combination of a recessed part, B, springs *b*, and the part A with shoulders or ledges *a*<sup>2</sup> for attaching the part A to the part B, and for readily detaching the same, substantially as hereinbefore described and illustrated in figures 24 to 30 of the accompanying drawings.

In witness whereof, I, the said Alfred Swan, have hereunto set my hand and seal, this fourteenth day of June, 1883.

ALFRED SWAN.

Signed and sealed at Newcastle-upon-Tyne, in the presence of—

ROBERT SPENCE WATSON,

Solicitor, Newcastle-upon-Tyne.

JAMES MASON LATHAEN,

Clerk to Messieurs Watson and Dendy, Solicitors, Newcastle-upon-Tyne.

This is the specification marked A referred to in the annexed Letters of Registration granted to Alfred Swan, this eleventh day of October, A.D. 1883.

AUGUSTUS LOFTUS.

## REPORT.

Sir,

We do ourselves the honor to report, in reply to your blank cover of the 24th August, No. 10,760, that we are of opinion Letters of Registration may be granted in favour of Mr. Alfred Swan for an invention described as "Improvements in the manufacture or construction of Incandescent Electric Lamps, and in machinery or apparatus employed therein, and Holders for Lamps," in terms of his Petition, specification, drawings, and claim.

The Under Secretary of Justice.

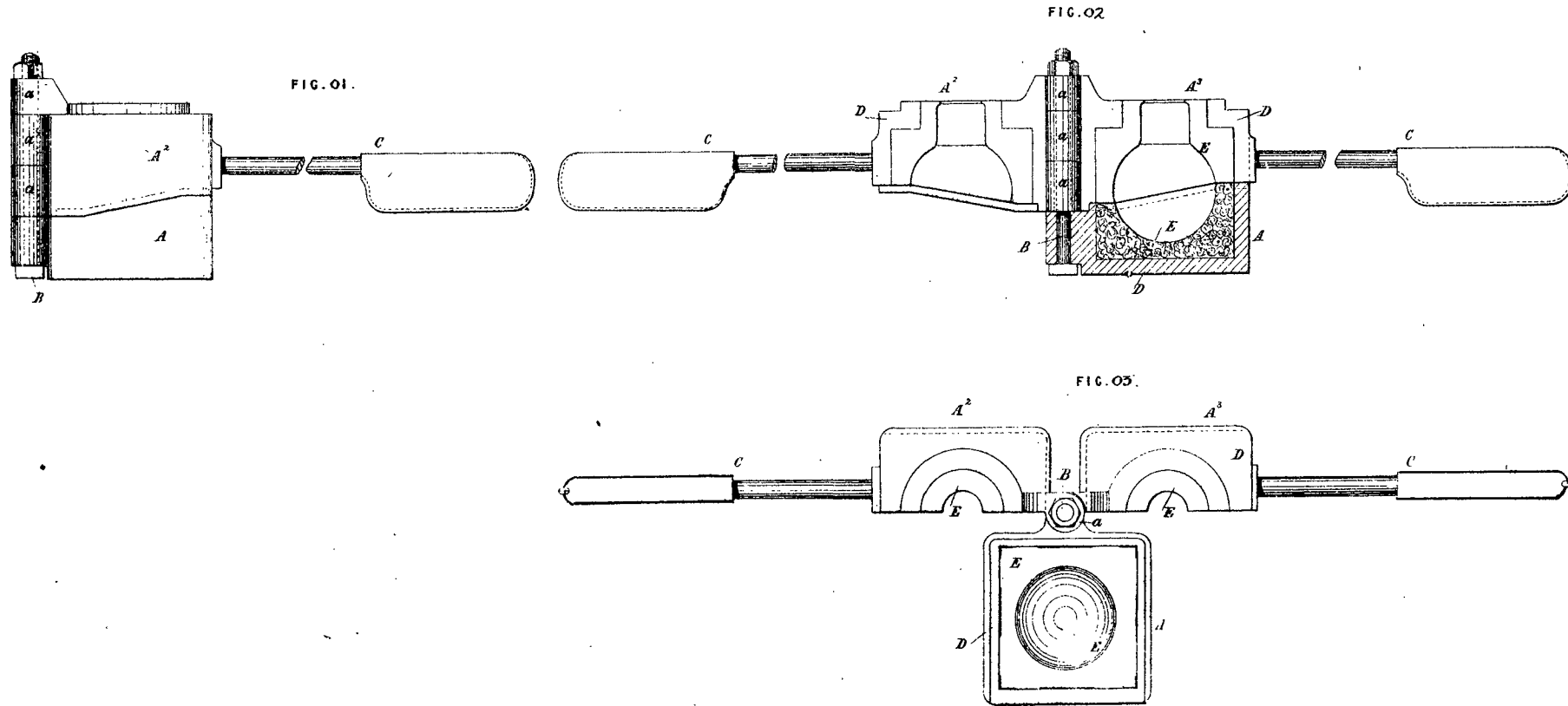
Sydney, 4 September, 1883.

We have, &c.,

E. C. CRACKNELL.

G. K. MANN.

[Drawings—four sheets.]

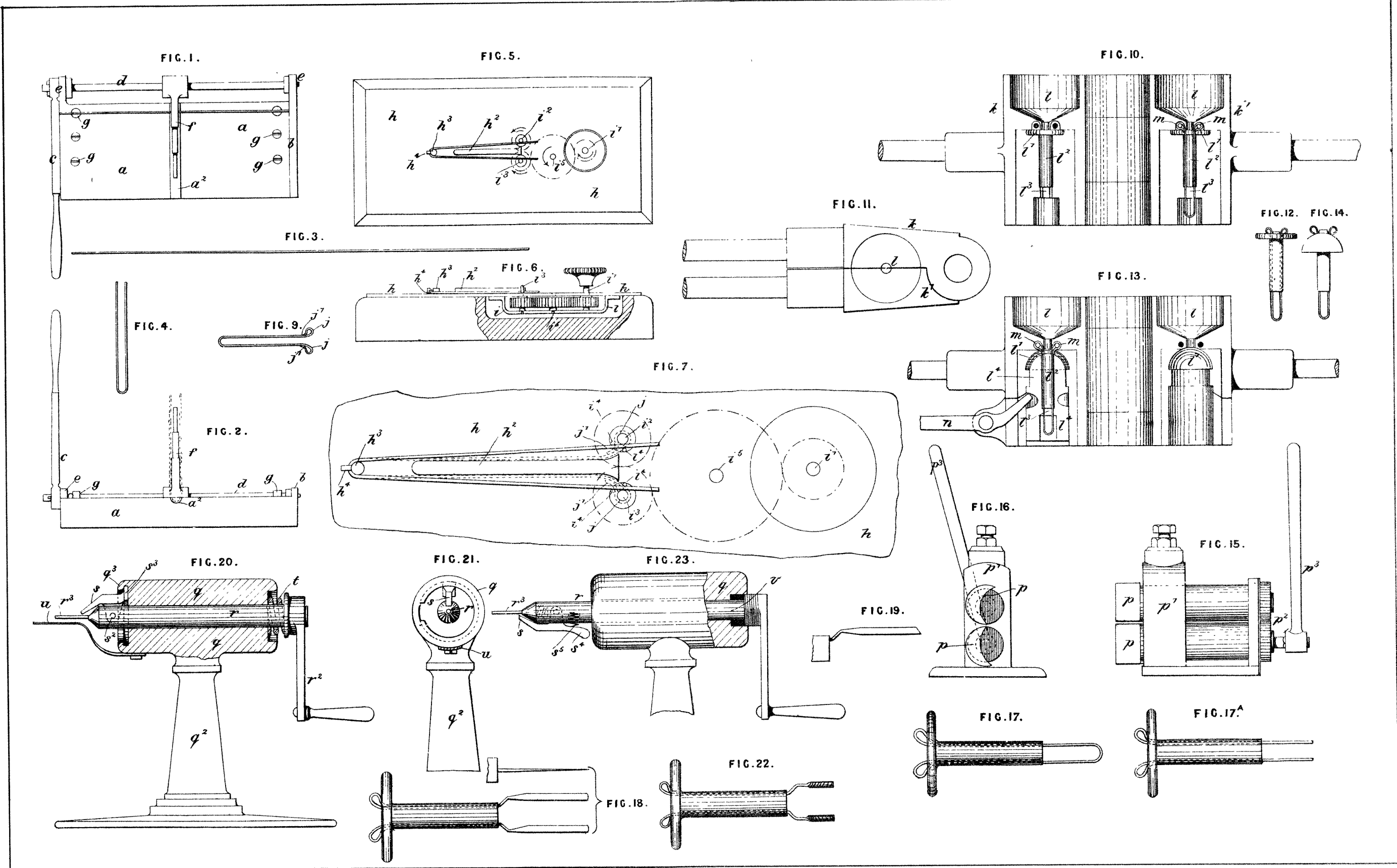


*This is the Sheet of Drawings marked 'B' referred to in the annexed Letters of Registration granted to Alfred Swan, this Eleventh day of October A.D. 1885.*

*(Sig. 35)*

*Augustus Loftus,*





This is the Sheet of Drawings marked 'C' referred to in the annexed  
 Letters of Registration granted to Alfred Swan, this eleventh day  
 (Sig. 35-) of October A.D. 1883.

Augustus Loftus.

PHOTO-LITHOGRAPHED AT THE GOVT. PRINTING OFFICE,  
 SYDNEY, NEW SOUTH WALES.

FIG. 14<sup>A</sup>

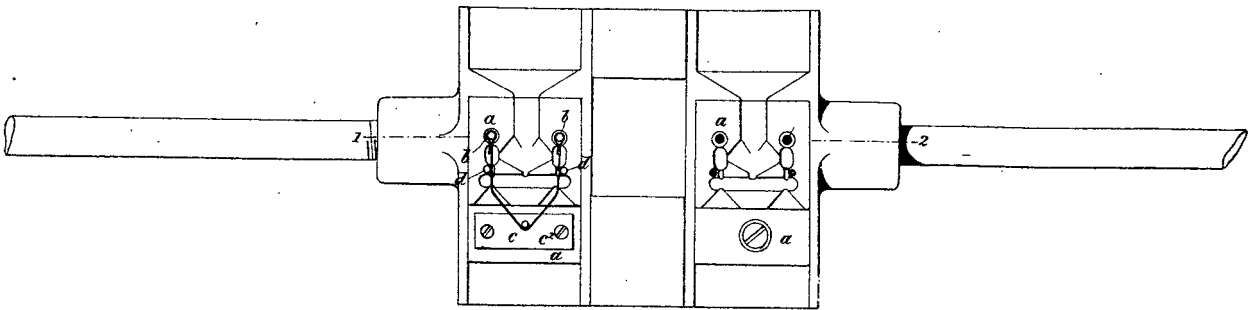


FIG. 14<sup>B</sup>

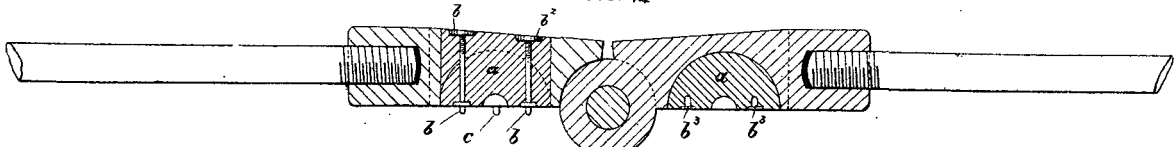


FIG. 14<sup>C</sup>

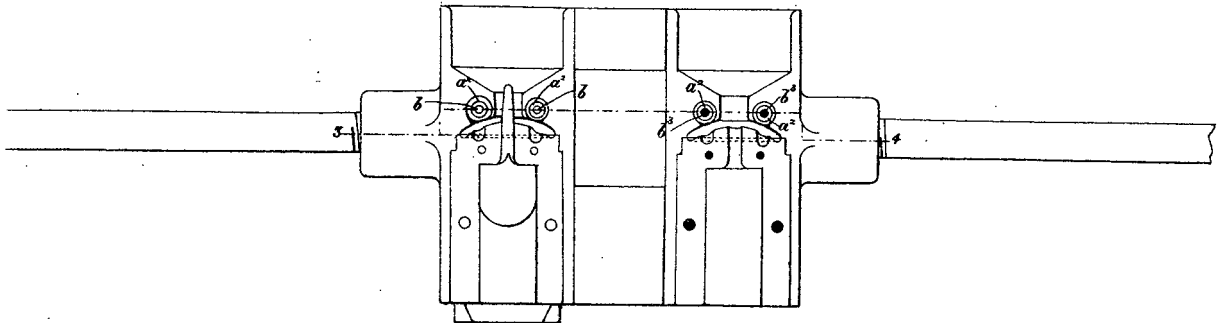
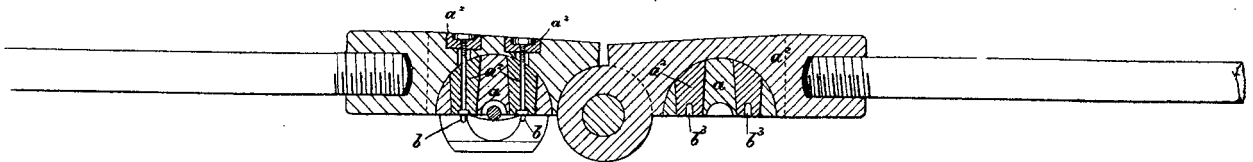


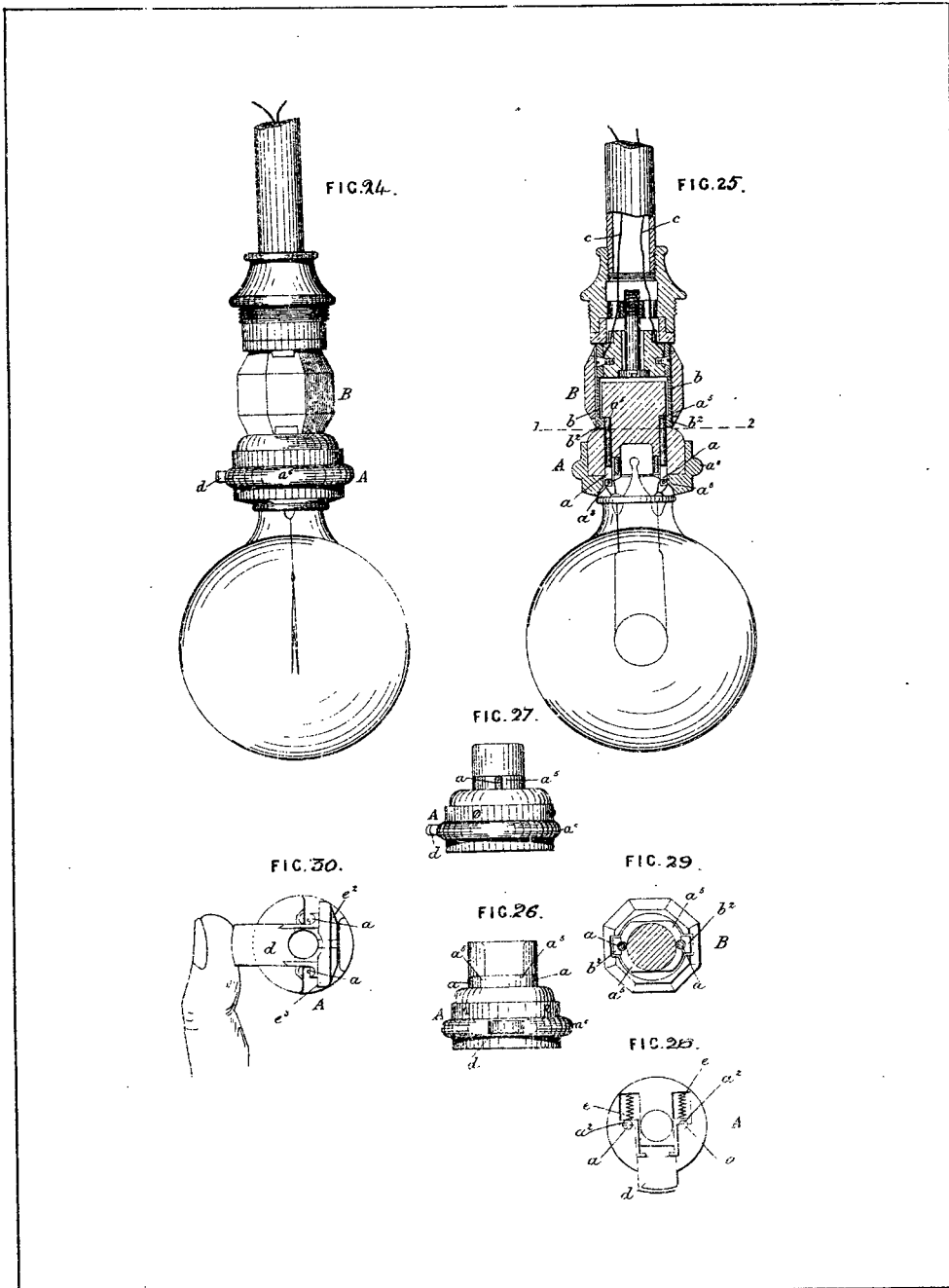
FIG. 14<sup>D</sup>



*This is the Sheet of Drawings marked 'D' referred to in the annexed  
Letters of Registration granted to Alfred Swan, this eleventh day of  
October A.D. 1883.*

(35-)

*Augustus Loftus.*



*This is the Sheet of Drawings marked 'B' referred to in the annexed Letters of Registration granted to Alfred Swan, this eleventh day of October A.D. 1883.*

*(Sig. 33.)*

*Augustus Loftus.*



A.D. 1883, 11th October. No. 1323.

**IMPROVEMENTS IN STOPPERING BOTTLES FOR CONTAINING AERATED OR GASEOUS LIQUIDS.**

**LETTERS OF REGISTRATION** to Richard John Sankey, for Improvements in Stoppering Bottles for containing Aërated or Gaseous Liquids.

[Registered on the 13th day of October, 1883, in pursuance of the Act 16 Vic. No. 24.]

BY HIS EXCELLENCY THE RIGHT HONORABLE SIR AUGUSTUS WILLIAM FREDERICK SPENCER LOFTUS (commonly called LORD AUGUSTUS LOFTUS), Knight Grand Cross of the Most Honorable Order of the Bath, a Member of Her Majesty's Most Honorable Privy Council, Governor and Commander-in-Chief of the Colony of New South Wales and its Dependencies.

TO ALL TO WHOM THESE PRESENTS SHALL COME, greeting :

WHEREAS RICHARD JOHN SANKEY, of London, England, farmer, hath by his Petition humbly represented to me that he is the author or designer of a certain invention or improvement in manufactures, that is to say, of an invention entitled "Improvements in Stoppering Bottles for containing Aërated or Gaseous Liquids," which is more particularly described in the specification and the sheet of drawings which are hereunto annexed; and that he, the said Petitioner, hath deposited with the Honorable the Treasurer of the said Colony of New South Wales the sum of Twenty Pounds sterling, for defraying the expense of granting these Letters of Registration, as required by the Act of Council, sixteenth Victoria, number twenty-four; and hath humbly prayed that I would be pleased to grant Letters of Registration, whereby the exclusive enjoyment and advantage of the said invention or improvement might be secured to him for a period of fourteen years: And I, being willing to give encouragement to all inventions and improvements in the arts or manufactures which may be for the public good, and having received a report favourable to the prayer of the said Petition from competent persons appointed by me to examine and consider the matters stated therein and to report thereon for my information, am pleased, with the advice of the Executive Council, and in exercise of the power and authority given to me by the said Act of Council, to grant, and do by these Letters of Registration grant unto the said Richard John Sankey, his executors, administrators, and assigns, the exclusive enjoyment and advantage of the said invention or improvement, for and during the term of fourteen years from the date hereof; to have, hold, and exercise unto the said Richard John Sankey, his executors, administrators, and assigns, the exclusive enjoyment and advantage thereof, for and during and unto the full end and term of fourteen years from the date of these presents next and immediately ensuing, and fully to be complete and ended: Provided always that if the said Richard John Sankey shall not, within three days after the granting of these Letters of Registration, register the same in the proper office in the Supreme Court, at Sydney, in the said Colony of New South Wales, then these Letters of Registration, and all advantages whatsoever hereby granted, shall cease and become void.

In witness whereof, I have hereunto set my sign manual, and have caused the present Letters of Registration to be sealed with the seal of the said Colony of New South Wales, at Government House, Sydney, in New South Wales, this eleventh day of October, in the year of our Lord one thousand eight hundred and eighty-three.

[L.S.]

AUGUSTUS LOFTUS.

*Improvements in Stoppering Bottles for containing Aërated or Gaseous Liquids.*

SPECIFICATION of RICHARD JOHN SANKEY, of London, England, farmer, for an invention entitled "Improvements in Stoppering Bottles for containing Aërated or Gaseous Liquids."

THIS invention relates to improvements in stoppering bottles for containing aërated or gaseous liquids when such bottles are closed by internal stoppers, and the improvements consist in improved methods of fitting and fixing in the neck of the bottle the india-rubber ring which forms the seat for the stopper to bear against, also to an improved internal stopper.

In one method of carrying out the first part of my invention I utilize the known property of hard india-rubber, usually called vulcanite or ebonite, by which such material, after having been expanded or contracted, will retain such expanded or contracted shape, until it be heated, when it will recover its original shape.

I employ a bottle having a shoulder or step in the neck thereof; the opening of the neck, either above or below the said step or shoulder, being somewhat of a conical shape, narrowing as it recedes from the shoulder or step. Over or under the shoulder or step, and resting thereon (the stopper having been previously inserted in the bottle) I place an india-rubber ring, such as is usually employed for use with internal stoppers; for fixing this india-rubber against the said shoulder or step I employ a ring of ebonite, made in the first instance of about the same size as the abovenamed india-rubber ring—that is to say, with a hole in the centre somewhat smaller than the diameter of the stopper. I then, by means of a suitable tool, compress the outside diameter of the ebonite ring to such a size that it can be passed into the bottle, and when the ring has been placed flat-wise upon the said rubber ring, heat is applied in a suitable manner to the ebonite ring, and in a short time the ebonite ring will expand until it tightly fits against the surface of the neck of the bottle, above or below the india-rubber ring, as the case may be, and will thus firmly hold the same against the hereinbefore described step or shoulder in the bottle-neck, so that it cannot be removed without first removing the ebonite ring.

Instead of employing a bottle with a shoulder or step in the neck, the interior of the neck of the bottle may be formed of a suitably double curved shape, and the india-rubber ring be secured between two ebonite rings.

I sometimes employ a cut ring of flexible material for the fixing ring, the said ring being sprung into the neck of the bottle; or a metal ring, which is expanded after being placed in the neck of the bottle.

The stopper which I find it advantageous to employ in combination with a seating constructed and fitted as hereinbefore described, consists of a hollow oval or double-cone shaped stopper of glass, porcelain, or other suitable sinkable material; the object of making the stopper hollow being to lighten it, so that in sinking to the bottom of the bottle when the bottle is opened, the stopper shall not break or injure the bottle, or be itself broken or injured.

Other suitable stoppers may, however, be used with my improved seating, and the hereinbefore described stopper may be used with the ordinary seating.

In order to enable my invention to be fully understood, I will proceed to describe the same by reference to the accompanying drawing, in which figure 1 shows a section of the mouth of a bottle provided with a seating according to one modification of my invention; figure 2, a similar view, but showing the internal stopper in the position it occupies when pressed against the seating; figure 3, an elevation of a complete bottle; figure 4, a section of the bottle neck without seating; figure 5, a detached plan of the india-rubber seating before being placed in the bottle; figure 6, plan of the vulcanite fixing ring before compression; and figure 7, a plan of the same after compression; figure 8, a view similar to figure 1, but showing the vulcanite ring before being expanded against the bottle neck; figure 9, a section of my improved hollow stopper; figure 10, section of a bottle neck, showing the elastic seating placed under a step or shoulder in the neck; and figure 11, a section of a bottle neck showing the elastic seating fixed in position by two vulcanite rings; figure 12 is a section of a bottle neck showing the elastic seating fixed therein by means of a cut flexible ring; figures 13 and 14, plans of the fixing ring. Similar letters in all the figures represent similar or corresponding parts.

I will first describe my improvements by reference to figures 1 to 9 inclusive.

*a* is the bottle, and *b* the step or shoulder in the neck thereof, the opening of the neck narrowing as it recedes from the shoulder *b*, so as to be somewhat of a conical shape. *c* is the improved stopper, formed hollow and of a double cone shape, as shown in the detached sectional view at figure 9, and made of suitable sinkable material. A stopper of this construction (or any other suitable known stopper) is placed in the bottle; I then place upon the step or shoulder, *b*, an ordinary vulcanized india-rubber ring, *d*, such as that shown in detached plan at figure 5, or a ring or seating of other suitable elastic material; to fix this seating in position I employ a ring of vulcanite, *e*, made in the first instance of about the diameter shown in the detached view at figure 6. I then compress this ring *e*, by suitable means, until it is reduced to such a diameter (as shown in figure 7) that it can be passed into the bottle *a*; the ring *e* is then laid flatwise upon the seating *d*, as shown in figure 8, and heat is applied to the vulcanite ring *e*, and in a short time it will expand until it tightly fits against the interior of the neck, as shown in figure 1, so as to firmly hold the seating *d* against the step or shoulder *b*, the conical shape of the mouth of the bottle preventing the ring *e* from rising.

The arrangement shown in figure 10 is substantially the same as that shown in figure 1, except that the seating *d* is fixed against the under-side of the shoulder *b*.

Figure 11 shows the bottle neck formed of an oval or double curved shape in the interior, the seating *d* being fixed between two vulcanite rings, *e e*<sup>1</sup>.

It is obvious that various methods equivalent to those above referred to may be employed for fixing the expanded ebonite or vulcanite ring (when used as proposed by me) firmly in its seat as required; for instance, suitable projections or recesses may be formed in the neck of the bottle, against or into which the ebonite ring or parts of it may be pressed, but the means I have hereinbefore shown seem to me to be most convenient, on the whole.

When I employ a cut flexible ring for fixing the elastic seating in position I proceed as follows:—

I employ a length of suitable flexible material, preferably circular in section, which is bent into the form of a ring *e*, as shown in figure 13, the diameter of the ring being such that it will tightly fit the interior of the neck of the bottle just above the seating *d*.

*Improvements in Stoppering Bottles for containing Aërated or Gaseous Liquids.*

To apply the said ring *e*, it is contracted by passing one end over the other, as shown in figure 14, and is then passed into the neck of the bottle so as to rest on the seating *d*, when it will spring out and become tightly fitted in the interior of the bottle neck, and will securely hold the seating *d* in its place as shown in figure 12.

In practice I have found vulcanite to answer well for the fixing-ring, but it will be evident that other suitable flexible material or metal may be employed for the fixing-ring.

The method of fixing the india-rubber seating in the neck of the bottle by means of a flexible ring, as hereinbefore described, allows of the seating being removed and replaced without having to break the fixing-ring, as the same can be easily removed when required.

It will be obvious that the fixing-ring need not be in one piece, but may be subdivided, each part being introduced separately so as to form a complete ring.

Instead of employing a ring of flexible material as hereinbefore described, I sometimes employ a complete ring of metal, of a diameter which will allow it to be passed into the bottle neck, and it is then expanded by a suitable tool until it tightly fits the neck of the bottle above the seating.

Having thus described my said invention, and the best means I am acquainted with for carrying the same into effect, I wish it to be understood that what I claim is—

Firstly—The method herein described of fixing an elastic seating in the necks of bottles by the employment of a ring or rings of hard india-rubber, usually called vulcanite or ebonite; the said vulcanite ring or rings being first reduced in diameter so that it or they may be passed into the neck of the bottle and then subjected to heat, so that the said ring or rings will expand and become tightly fitted in the interior of the bottle neck, as hereinbefore described.

Secondly—A bottle for internal stoppers, having a seating fixed against a shoulder in the neck thereof by means of a ring of vulcanite, substantially in the manner hereinbefore described, and represented in figures 1, 2, 3, and 10 of the accompanying drawing.

Thirdly—A bottle for internal stoppers, having a seating fixed in the neck thereof by means of two vulcanite rings, substantially in the manner hereinbefore described, and represented in figure 11 of the accompanying drawing.

Fourthly—The method herein described of fixing an elastic seating in the necks of bottles by the employment of a cut ring of suitable material, as hereinbefore described.

Fifthly—The method herein described of fixing an elastic seating in the necks of bottles by the employment of a metal ring, introduced into the bottle neck and then expanded, as hereinbefore described.

Sixthly—A bottle for internal stoppers, having a seating fixed against a shoulder in the neck thereof by means of a cut ring of suitable flexible material, or of an expanded ring of metal, substantially in the manner hereinbefore described, and illustrated in figures 12, 13, and 14 of the accompanying drawing.

In witness whereof, I, the said Richard John Sankey, have hereto set my hand and seal, this twenty-eighth day of June, one thousand eight hundred and eighty-three.

R. J. SANKEY.

Witness—

A. ALBUTT, 4, South-street, Finsbury, London.

This is the specification referred to in the annexed Letters of Registration granted to Richard John Sankey, this eleventh day of October, A.D. 1883.

AUGUSTUS LOFTUS.

## REPORT.

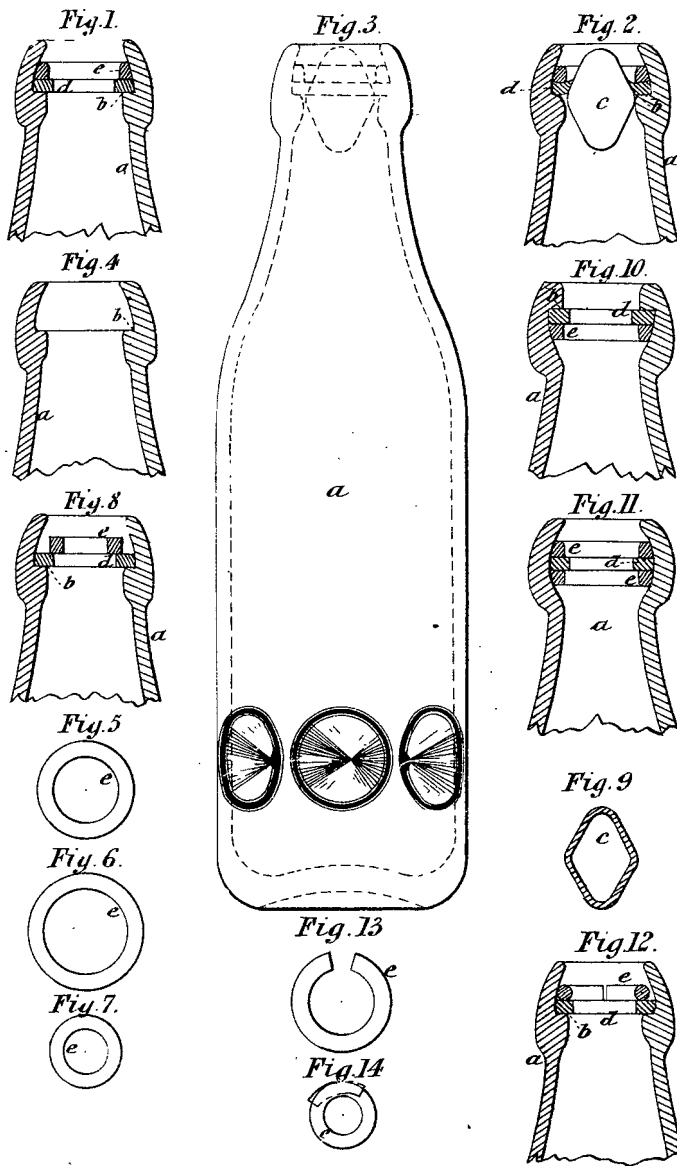
Sir,

The application of Richard John Sankey for Letters of Registration for an invention entitled "Improvements in Stoppering Bottles for containing Aërated and Gaseous Liquids," having been referred to us for report, we have examined the specification and plans accompanying the same, and have now the honor to report that we see no objection to the issue of Letters of Registration as applied for.

We have, &c.,

ARCH. FRASER.  
THOS. RICHARDS.

The Under Secretary of Justice.



*This is the Sheet of Drawings referred to in the annexed  
 Letters of Registration granted to Richard John Saubey  
 this eleventh day of October A.D. 1883.*

*Augustus Loftus.*



A.D. 1883, 11th October. No. 1324.

**AN IMPROVED MACHINE TO BE USED IN THE MANUFACTURE OF CARTRIDGES FROM DYNAMITE, &c.**

LETTERS OF REGISTRATION to Thomas Tolley Jones, for an Improved Machine to be used in the Manufacture of Cartridges from Dynamite and other Nitro-glycerine compounds, for Mining, Blasting, and kindred purposes.

[Registered on the 13th day of October, 1883, in pursuance of the Act 16 Vic. No. 24.]

BY HIS EXCELLENCY THE RIGHT HONORABLE SIR AUGUSTUS WILLIAM FREDERICK SPENCER LOFTUS (commonly called LORD AUGUSTUS LOFTUS), Knight Grand Cross of the Most Honorable Order of the Bath, a Member of Her Majesty's Most Honorable Privy Council, Governor and Commander-in-Chief of the Colony of New South Wales and its Dependencies.

TO ALL TO WHOM THESE PRESENTS SHALL COME, greeting :

WHEREAS THOMAS TOLLEY JONES, of No. 31, Little Collins-street East, in the City of Melbourne, and Colony of Victoria, merchant, hath by his Petition humbly represented to me that he is the author or designer of a certain invention or improvement in manufactures, that is to say, of an invention entitled "An Improved Machine to be used in the Manufacture of Cartridges from Dynamite and other Nitro-glycerine compounds, for Mining, Blasting, and kindred purposes," which is more particularly described in the specification and the sheet of drawings which are hereunto annexed; and that he, the said Petitioner, hath deposited with the Honorable the Treasurer of the said Colony of New South Wales the sum of Twenty Pounds sterling, for defraying the expense of granting these Letters of Registration, as required by the Act of Council, sixteenth Victoria, number twenty-four; and hath humbly prayed that I would be pleased to grant Letters of Registration, whereby the exclusive enjoyment and advantage of the said invention or improvement might be secured to him for a period of fourteen years: And I, being willing to give encouragement to all inventions and improvements in the arts or manufactures which may be for the public good, and having received a report favourable to the prayer of the said Petition from competent persons appointed by me to examine and consider the matters stated therein and to report thereon for my information, am pleased, with the advice of the Executive Council, and in exercise of the power and authority given to me by the said Act of Council, to grant, and do by these Letters of Registration grant unto the said Thomas Tolley Jones, his executors, administrators, and assigns, the exclusive enjoyment and advantage of the said invention or improvement for and during the term of fourteen years from the date hereof; to have, hold, and exercise unto the said Thomas Tolley Jones, his executors administrators, and assigns, the exclusive enjoyment and advantage thereof, for and during and unto the full end and term of fourteen years from the date of these presents next and immediately ensuing, and fully to be complete and ended: Provided always, that if the said Thomas Tolley Jones shall not, within three days after the granting of these Letters of Registration, register the same in the proper office of the Supreme Court, at Sydney, in the said Colony of New South Wales, then these Letters of Registration, and all advantages whatsoever hereby granted, shall cease and become void.

In witness whereof, I have hereunto set my sign manual, and have caused the present Letters of Registration to be sealed with the seal of the said Colony of New South Wales, at Government House, Sydney, in New South Wales, this eleventh day of October, in the year of our Lord one thousand eight hundred and eighty-three.

[L.s.]

AUGUSTUS LOFTUS.



*Improved Machine to be used in the Manufacture of Dynamite Cartridges.*

SPECIFICATION of THOMAS TOLLEY JONES, of No. 31, Little Collins-street East, in the City of Melbourne, and Colony of Victoria, merchant, for an invention entitled "An Improved Machine to be used in the Manufacture of Cartridges from Dynamite and other Nitro-glycerine compounds, for Mining, Blasting, and kindred purposes."

CARTRIDGES of nitro-glycerine compounds have hitherto been shaped by hand because of the tendency of such compounds to explode with a small amount of pressure or friction. This is a costly method, and the nitro-glycerine they contain has a tendency to exude. Now, I have ascertained by careful experiment that these cartridges may be shaped without danger to the operator by a certain description of machine, and that when so shaped the nitro-glycerine therein has a less tendency to exude than before, and consequently that cartridges so made are safer for use and transport.

I find that by ramming small quantities of nitro-glycerine compounds at a time into and through a tube that such compounds attain a certain evenness of composition and regularity of shape that is unattainable by hand, and that the density of the composition is entirely determinable by the length of tube through which such compounds are forced—the longer the tube the greater the density. I have, therefore, devised a machine which carries this principle into effect, and at the same time carefully avoids any friction and undue pressure to the compound. This machine constitutes the invention for which I now seek Letters of Registration.

Figure 1 shows side view of my machine, with the feed-box, rammer, and tube in section; figure 2 shows plan of same. A is the tube made of, say, bell-metal, and having its mouth, A<sup>1</sup>, flared outwards, as shown, for the more ready reception of the compound. This tube is fitted into the end B<sup>1</sup> of the feed-box B. The bottom of this box is curved or hollowed, and is made sufficiently deep to allow of the wooden rammers C moving to and from the tube without causing any friction. The front end B<sup>2</sup> of the feed-box is made of flexible material (such as engineer's "insertion"), and fits tightly around the rammers with which it is carried backward and forward like a flexible diaphragm. This wooden rammer extends backward as far as B<sup>3</sup> (see figure 2), and fits in a metal tube, B<sup>4</sup>. This tube is connected to the stem B<sup>5</sup> of the rammer, which may be made hollow or solid, but which I prefer to make hollow, and of metal. It works in guides D D, and is moved to and fro by connecting rod E, attached to eccentric E<sup>1</sup>, on revolving shaft E<sup>2</sup>, as is well understood.

In operation the nitro-glycerine compound is supplied in small quantities to the feed-box B, and by the motion of the rammers C driven at, say, one hundred strokes per minute, is gradually forced into and through the tubes A, being cut off by the attendant in convenient lengths as it is discharged therefrom, and encased in the usual material.

It will be noticed that the rammers are made slightly smaller than the inside measurement of the tubes they are to fill, and that they only enter the flared mouth, say one-eighth of an inch, thereby avoiding any friction and any undue pressure.

It is evident that any number of rammers may be used in one machine, and that the motion thereto may be given by a variety of mechanical contrivances. I do not, therefore, confine myself to such details so long as the nature and essence of my invention be retained, but what I claim as novel in my improved machine to be used in the manufacture of cartridges from dynamite and other nitro-glycerine compounds is:—

First—So constructing such machines as that the material with which they are fed is rammed into and through tubes of the size of the cartridges required.

Second—So constructing such machines as that the rammers do not touch either the tubes or the feed-box, and with a flexible front end to such box fitting tightly on the rammers.

In witness whereof, I, the said Thomas Tolley Jones, have hereto set my hand and seal, this twenty-fifth day of July, one thousand eight hundred and eighty-three.

Witness—

W. S. BAYSTON,

Clerk to Edwd. Waters, Patent Agent, Melbourne.

T. TOLLEY JONES.

This is the specification referred to in the annexed Letters of Registration granted to Thomas Tolley Jones, this 11th day of October, A.D. 1883.

AUGUSTUS LOFTUS.

## REPORT.

Sir,

The application of Mr. Thomas Tolley Jones for Letters of Registration for an "Improved Machine to be used in the Manufacture of Cartridges from Dynamite and other Nitro-glycerine compounds, for Mining, Blasting, and kindred purposes," having been referred to us, we have examined the specification and drawings accompanying the same, and have now the honor to report that we see no objection to the issue of Letters of Registration as prayed for.

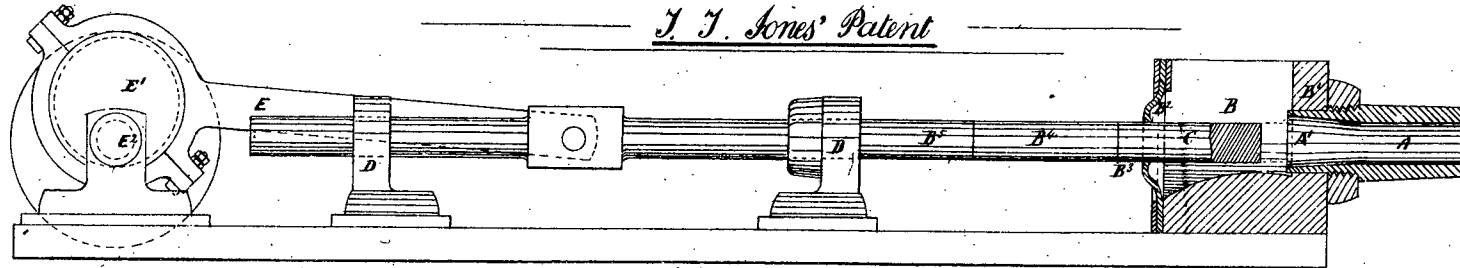
The Under Secretary of Justice

We have, &c.,

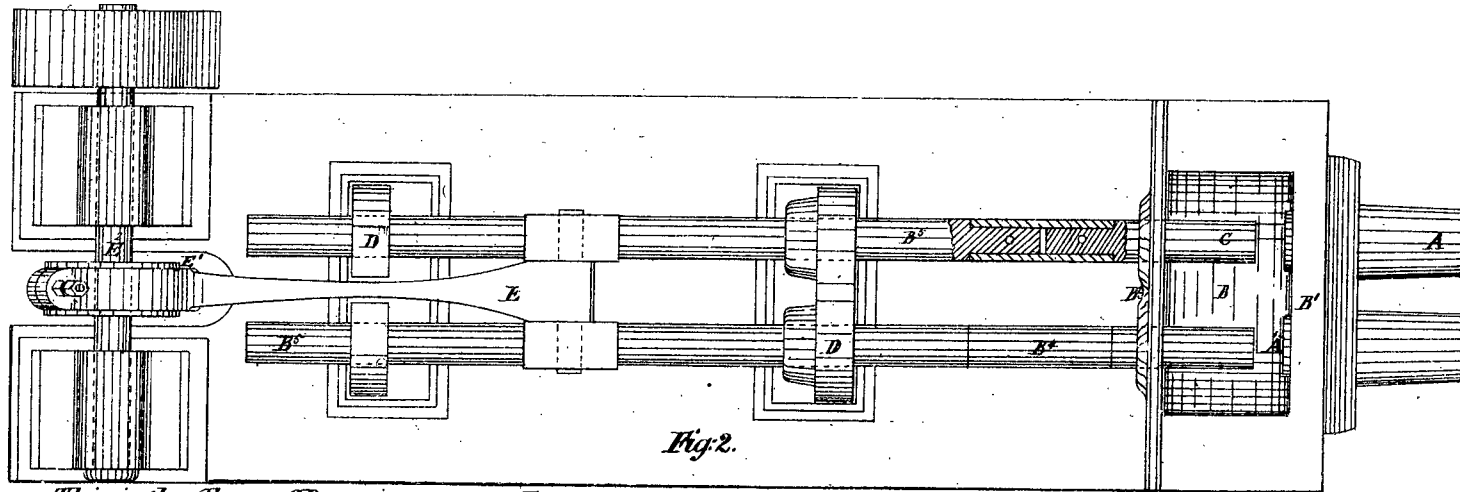
CHAS. WATT.

EDMUND FOSBERY.

*J. J. Jones' Patent*



*Fig. 1.*



*Fig. 2.*

*This is the Sheet of Drawings referred to in the annexed  
Letters of Registration granted to Thomas Tolley Jones, this  
Eleventh day of October A.D. 1883.*

*Augustus Loftus.*



A.D. 1883, 11th October. No. 1325.

**IMPROVEMENTS IN MACHINERY FOR TURNING OR SHAPING SOLID MATERIAL  
TO AN IRREGULAR OR REGULAR PATTERN.**

**LETTERS OF REGISTRATION** to James Brookhouse Preston and James Shepherd for Improvements in Machinery for turning or shaping Solid Material to an irregular or regular pattern.

[Registered on the 13th day of October, 1883, in pursuance of the Act 16 Vic. No. 24.]

BY HIS EXCELLENCY THE RIGHT HONORABLE SIR AUGUSTUS WILLIAM FREDERICK SPENCER LOFTUS (commonly called LORD AUGUSTUS LOFTUS), Knight Grand Cross of the Most Honorable Order of the Bath, a Member of Her Majesty's Most Honorable Privy Council, Governor and Commander-in-Chief of the Colony of New South Wales and its Dependencies.

TO ALL TO WHOM THESE PRESENTS SHALL COME, greeting:—

WHEREAS JAMES BROOKHOUSE PRESTON, engineer, and JAMES SHEPHERD, builder, both of Sydney, in the Colony of New South Wales, have by their Petition humbly represented to me that they are the authors, or designers, and the assignees of a certain invention or improvement in manufactures, that is to say, of an invention entitled "Improvements in Machinery for turning or shaping Solid Material to an irregular or regular pattern," which is more particularly described in the specification and the sheet of drawings which are hereunto annexed; and that they, the said Petitioners, have deposited with the Honorable the Treasurer of the said Colony of New South Wales the sum of Twenty Pounds sterling for defraying the expense of granting these Letters of Registration, as required by the Act of Council, sixteenth Victoria, number twenty-four; and have humbly prayed that I would be pleased to grant Letters of Registration, whereby the exclusive enjoyment and advantage of the said invention or improvement might be secured to them for a period of fourteen years: And I, being willing to give encouragement to all inventions and improvements in the arts or manufactures which may be for the public good, and having received a report favourable to the prayer of the said Petition, from competent persons appointed by me to examine and consider the matters stated therein and to report thereon for my information, am pleased, with the advice of the Executive Council, and in exercise of the power and authority given to me by the said Act of Council, to grant, and do by these Letters of Registration grant unto the said James Brookhouse Preston and James Shepherd, their executors, administrators, and assigns, the exclusive enjoyment and advantage of the said invention or improvement for and during the term of fourteen years from the date hereof; to have, hold, and exercise unto the said James Brookhouse Preston and James Shepherd, their executors, administrators, and assigns, the exclusive enjoyment and advantage thereof for and during and unto the full end and term of fourteen years from the date of these presents next and immediately ensuing, and fully to be complete and ended: Provided always, that if the said James Brookhouse Preston and James Shepherd shall not, within three days after the granting of these Letters of Registration, register the same in the proper office in the Supreme Court, at Sydney, in the said Colony of New South Wales, then these Letters of Registration, and all advantages whatsoever hereby granted, shall cease and become void.

In witness whereof, I have hereunto set my sign manual, and have caused the present Letters of Registration to be sealed with the seal of the said Colony of New South Wales, at Government House, Sydney, in New South Wales, this eleventh day of October, in the year of our Lord one thousand eight hundred and eighty-three.

[L.s.]

AUGUSTUS LOFTUS.

*Improvements in Machinery for turning or shaping Solid Material.*

SPECIFICATION of JAMES BROOKHOUSE PRESTON, engineer, and JAMES SHEPHERD, builder, both of Sydney, in the Colony of New South Wales, for an invention entitled "Improvements in Machinery for turning or shaping Solid Material to an irregular or regular pattern."

OUR invention has been specially designed to produce an efficient and economical machine for the purpose of turning spokes of wheels, pick-handles, axe-handles, and such like irregular shaped articles; but it may also be used for turning regular or tapered articles.

Our improvements in machinery for turning or shaping solid material to an irregular or regular pattern, consists first and essentially in travelling a balanced carriage or frame, carrying a pattern revolving between two centres, and an undressed piece of material, revolving between two other centres, to and fro between a stationary loose roller disc, and a revolving—but also stationary—cutting implement or tool, so that when either the pattern is pressed to said disc or the undressed block to said cutting implement the block will be cut away until it becomes the exact counterpart of the pattern.

Our improvements consist further in use of a circular saw preferably set at an angle to the line of travel of the material, as the cutting implement of such machinery, and in the particular combination and arrangement of parts, forming a complete machine for such purpose.

Our improved machine consists of an ordinary trestle frame carrying the bearings of a spindle or shaft which we call the "main shaft." One end of this shaft to its middle or thereabouts is screwed or has a thread, while the other part has a groove or key-way cut in it. It is provided with gearing or pulleys, as is well understood, for revolving it in either direction. The travelling balanced carriage or frame rides upon said main shaft by means of a fixed nut or female screw at one end, and a double bearing at the other, and it has ordinary lathe centres with tightening screws on either side of the main shaft. Between the double bearings of said carriage is a sliding toothed wheel whose key fits and travels in the groove in the main shaft, and geared with said wheel are toothed wheels on the head stocks of the lathe centres. On one side of the main shaft about the centre and above the trestle frame, an adjustable bracket or arm from said frame carries a loose revolving roller disc, and upon the other side, but below the frame, another arm or bracket carries the bearings for the spindle of a circular saw and its driving pulleys.

But in order that our invention may be clearly understood, reference will now be had to the drawings forming part of this specification; in which figure 1 is a side elevation of a machine constructed according to our invention for shaping or turning timber to a pattern; and figure 2 a plan of the same; while figure 3 is a section through line  $a^* b^*$  in figure 2.

$a b$  is the main shaft, end  $a$  being screwed, and end  $b$  having a key-way or groove, and having driving pulleys  $l$ , as is well understood;  $e$  is the balanced frame or carriage;  $e^1$  and  $e^2$  are one pair of lathe centres, and  $e^3$  and  $e^4$  are a second pair;  $f$  is a nut or female screw fixed to frame  $e$ , and  $f^1$  the bearing of said frame at its other end;  $c$  is a spur or toothed wheel which has a key fitting in the groove of main shaft  $a b$ ;  $d^1$  and  $d^2$  are toothed wheels on headstocks  $e^3$  and  $e^4$  respectively;  $g$  is a loose roller disc, carried upon adjustable arm  $g^1$ ;  $k$  is a circular saw,  $k^1$  its bearings, and  $k^2$  its pulleys;  $m$  is the trestle frame of the whole.

The mode of operation is as follows:—A pattern,  $h$ , say of a wheel spoke, is placed between centres  $e^1 c^3$ , and an undressed block of timber,  $i$ , between centres  $e^2 e^4$ , and a slight pressure brought to bear on the latter side of the frame  $e$ , just sufficient to bring it into contact with the revolving saw  $k$ . The main shaft  $a b$  is set in motion and revolves the pattern  $h$  and block  $i$  by means of wheels  $c$ ,  $d^1$  and  $d^2$ , and travels in the frame  $e$  as well, by means of nut  $f$ . The block  $i$ , is thus cut away by saw  $k$ , until the disc  $g$  touches the pattern  $h$ , which now guides the block  $i$  to and from the saw  $g$ , as said block passes backward and forward, and an exact counterpart of said pattern is produced. It is only necessary to give the slight pressure on the side of the frame above the saw, and to give attention so as to reverse the main shaft when necessary by means of pulleys  $l$ . By lowering or raising the disc  $g$ , by means of adjustable arm  $g^1$ , an article larger or smaller respectively than the pattern will be produced.

We prefer that the roller disc  $g$ , and the circular saw  $k$ , should be of the same diameter, and exactly the same distance from the centre of the main shaft, and the lathe centres also at equal distances from such main shaft; but it is clearly to be seen that so long as these parts are made in the proper proportion, and proportional distances, that it is not absolutely necessary for such to be the case. We are aware that other cutting implements might be used instead of the revolving saw, but we have found that said circular saw set at an angle performs the work required more speedily and with better results as to finish. For metal work we would use ordinary turning tools.

Having thus fully described and explained our said invention, and the manner in which the same is to be performed, what we believe to be new, and therefore claim as our invention in machinery for turning or shaping material to an irregular or regular pattern, is—

First—Travelling a balanced carriage frame provided with lathe centres—carrying the pattern and the material—to and fro between a stationary roller disc, and a stationary cutting implement, substantially as herein described and explained.

Secondly—The combination with said travelling frame and stationary roller disc of a revolving circular saw (whether or not set at an angle) as the cutting implement.

Thirdly—The combination and arrangement of parts forming a complete machine, substantially as herein described and explained, and as illustrated in the drawings.

In witness whereof, we, the said James Brookhouse Preston and James Shepherd, have hereto set our hands and seals, this seventeenth day of August, one thousand eight hundred and eighty-three.

Witness—

FRED. WALSH,  
Manager, Edwd. Waters' Patent Office, Sydney.

JAMES B. PRESTON.  
JAMES SHEPHERD.

This is the specification referred to in the annexed Letters of Registration granted to James Brookhouse Preston and James Shepherd, this eleventh day of October, A.D. 1883.

AUGUSTUS LOFTUS.

REPORT.

---

*Improvements in Machinery for turning or shaping Solid Material.*

---

REPORT.

---

Sir,

We do ourselves the honor to report, in reply to your blank cover of the 18th instant, No. 10,527, transmitting Messrs. James Brookhouse Preston and James Shepherd's Petition for the registration of "Improvements in Machinery for turning or shaping Solid Material to an irregular or regular pattern," that we are of opinion the prayer of the Petitioners may be granted in terms of their specification, drawings, or claim.

Sydney, 30 August, 1883.

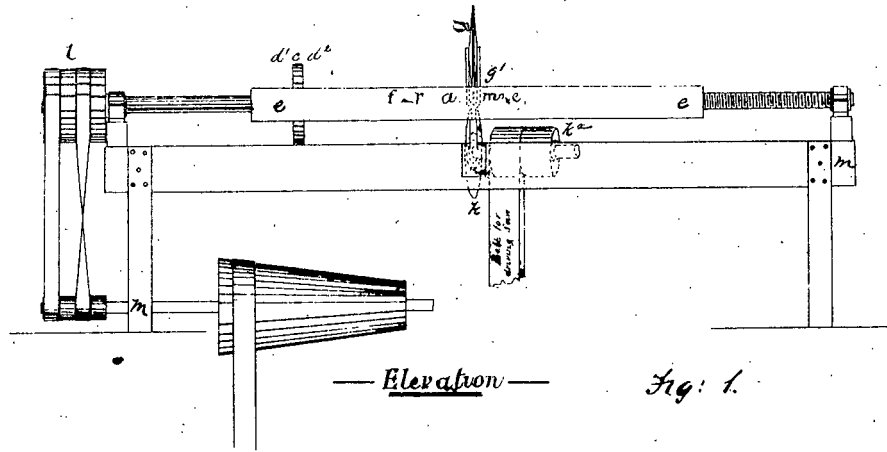
We have, &c.,

JAMES BARNET.  
GOTHER K. MANN.

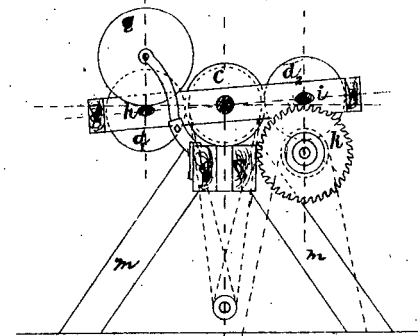
The Under Secretary of Justice.

---

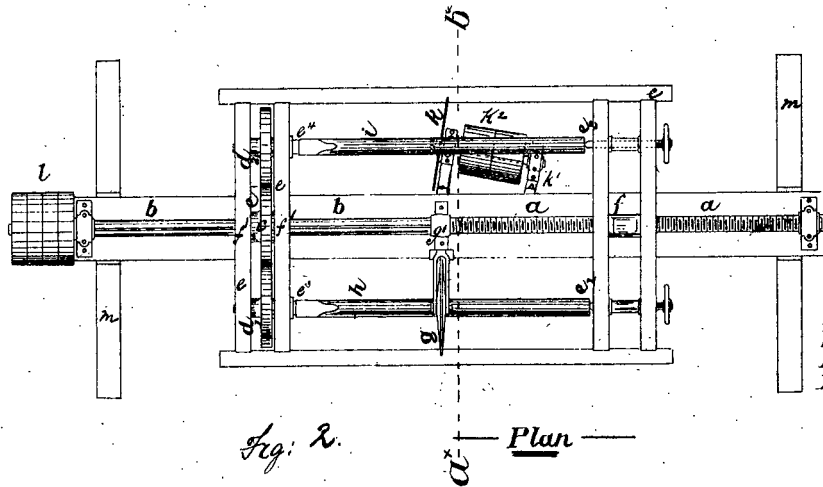
[Drawings—one sheet.]



— Elevation — *Fig: 1.*



— Section through A.B. —  
*Fig: 3.*



*Fig: 2.* — Plan —

*This is the Sheet of Drawings referred to in the annexed  
Letters of Registration granted to James Brookhouse  
Preston and James Shepherd, this Eleventh day of October,  
A. D. 1883.*

*Augustus Loftus*



A.D. 1883, 11th October. No. 1326.

**IMPROVEMENTS IN THE MANUFACTURE OF SILICIOUS COPPER AND SILICIOUS BRONZE.**

**LETTERS OF REGISTRATION** to Lazare Weiller, for Improvements in the Manufacture of Silicious Copper and Silicious Bronze, and the preparation of certain compounds suitable to be employed in such manufacture.

[Registered on the 13th day of October, 1883, in pursuance of the Act 16 Vic. No. 24.]

BY HIS EXCELLENCY THE RIGHT HONORABLE SIR AUGUSTUS WILLIAM FREDERICK SPENCER LOFTUS (commonly called LORD AUGUSTUS LOFTUS), Knight Grand Cross of the Most Honorable Order of the Bath, a Member of Her Majesty's Most Honorable Privy Council, Governor and Commander-in-Chief of the Colony of New South Wales and its Dependencies.

TO ALL TO WHOM THESE PRESENTS SHALL COME, greeting :

WHEREAS LAZARE WEILLER, of Angoulême, in the Republic of France, chemist, hath by his Petition humbly represented to me that he is the author or designer of a certain invention or improvement in manufactures, that is to say, of an invention entitled "Improvements in the Manufacture of Silicious Copper and Silicious Bronze, and the preparation of certain compounds suitable to be employed in such manufacture," which is more particularly described in the specification which is hereunto annexed; and that he, the said Petitioner, hath deposited with the Honorable the Treasurer of the said Colony of New South Wales the sum of Twenty Pounds sterling, for defraying the expense of granting these Letters of Registration as required by the Act of Council, sixteenth Victoria, number twenty-four; and hath humbly prayed that I would be pleased to grant Letters of Registration, whereby the exclusive enjoyment and advantage of the said invention or improvement might be secured to him for a period of fourteen years: And I, being willing to give encouragement to all inventions and improvements in the arts or manufactures which may be for the public good, and having received a report favourable to the prayer of the said Petition, from competent persons appointed by me to examine and consider the matters stated therein and to report thereon for my information, am pleased with the advice of the Executive Council, and in exercise of the power and authority given to me by the said Act of Council to grant, and do by these Letters of Registration grant unto the said Lazare Weiller, his executors, administrators, and assigns, the exclusive enjoyment and advantage of the said invention or improvement, for and during the term of fourteen years from the date hereof; to have, hold, and exercise unto the said Lazare Weiller, his executors, administrators, and assigns, the exclusive enjoyment and advantage thereof, for and during and unto the full end and term of fourteen years from the date of these presents next and immediately ensuing, and fully to be complete and ended: Provided always, that if the said Lazare Weiller shall not, within three days after the granting of these Letters of Registration, register the same in the proper office in the Supreme Court, at Sydney, in the said Colony of New South Wales, then these Letters of Registration, and all advantages whatsoever hereby granted, shall cease and become void.

In witness whereof, I have hereunto set my sign manual, and have caused the present Letters of Registration to be sealed with the seal of the said Colony of New South Wales, at Government House, Sydney, in New South Wales, this eleventh day of October, in the year of our Lord one thousand eight hundred and eighty-three.

[L.S.]

AUGUSTUS LOFTUS.

*Improvements in the Manufacture of Silicious Copper and Silicious Bronze.*

SPECIFICATION of LAZARE WEILLER, of Angoulême, in the Republic of France, chemist, for an invention entitled "Improvements in the Manufacture of Silicious Copper and Silicious Bronze, and the preparation of certain compounds suitable to be employed in such manufacture."

THIS invention relates to the manufacture of silicious copper, or silicious bronze, or silicious alloys of copper, which are particularly suited for making electric conducting wires, as well as wires for other purposes, machinery, parts of machinery, and guns.

In the specification of former Letters of Registration granted to me, 27th June, 1883, I describe an economical process of manufacturing silicious copper and silicious bronze on a commercial scale. The said process has been found to give good results. The present invention relates, however, to substituting in certain cases, for the materials used in that process for producing the sodium necessary during the operation, an amount of sodium, meaning thereby the metallic base of soda combined with tin, or with tin and copper, when it is required to make silicious bronze. In this way there can be obtained on a commercial scale as much as 12 per cent. of silicium in an alloy, by causing one part of sodium combined with tin or with tin and copper to act upon from  $2\frac{1}{2}$  to 4 parts of fluosilicate of potass, introduced directly into the alloy. In the new process of making silicious bronze a previous combination of tin with sodium is made, and this combination I call "sodium-tin," and when I wish to add copper I mix sodium-tin therewith, and the compound thus formed I call "sodium-bronze."

The present invention thus comprises the manufacture of these compounds for the purpose of subsequently forming a combination of silicium with them or one of them, in the presence of or by means of fluosilicate of potass when melted with copper or bronze to form the required silicious alloy.

The said compound, sodium-tin, is made by first melting the tin in a crucible and stirring the molten metal while the sodium is very gradually added thereto; the compound thus made may then be allowed to cool and may be kept for use as required. In order to make sodium-bronze I add to melted copper the desired proportion of sodium-tin.

Instead of forming these compounds previously, the process of manufacturing silicious bronze may be modified by making a direct mixture of the metals which would form the silicious bronze; tin and sodium with the desired amount of fluosilicate of potass would then be introduced into the melted copper or bronze; or if the bronze already contained sufficient tin, only the sodium and fluosilicate would be introduced. In like manner, if it is desired to make silicious copper, the sodium is introduced with fluosilicate of potass into the melted copper. In all cases where sodium is used uncombined with tin it must be introduced very gradually into the melted metal. The fluosilicate should be introduced first, then the sodium, and lastly the tin when this is to be added.

When a larger amount of sodium is required than can be conveniently combined with the tin to be employed in the alloy, sodium in an uncombined state can be used in conjunction with the sodium-tin or sodium-bronze, the sodium and the sodium-tin or sodium-bronze being introduced with fluosilicate of potass into the melted copper or bronze.

The new process is therefore complementary to the process described in my said former specification. It enables me to obtain not only wires adapted for use in connection with telegraphs, telephones, and the conduction of electricity generally, but also wire for other purposes, and also to manufacture machinery, or parts of machinery, and guns which will offer great resistance to friction, blows, strain and other molecular disturbance.

For the manufacture of the new compound, sodium-tin, I generally employ from 5 to 30 parts of sodium to 100 parts of tin; for the manufacture of sodium-bronze, I generally use an amount of sodium-tin which will give an amount of tin equal to about 0.10 to 15 per cent. of the copper.

For the manufacture of silicious copper or silicious bronze the quantity of fluosilicate of potass which should be used to cause the combination of the silicium with the sodium is about  $2\frac{1}{2}$  to 4 times the weight of sodium employed, whether such sodium be introduced into the melted copper or bronze in a separate state, or (for the manufacture of silicious bronze) it be combined with tin in the form which I call sodium tin, or with tin and copper in the form of sodium-bronze.

The materials thus added to the melted copper or bronze react in the midst of the mass during the fusion of the alloy, and by this process it is easy to get a considerable quantity of silicium alloyed or mixed with the metal.

For the manufacture of silicious bronze the proportion of the tin may be considerably varied from, say, about 0.10 to 15 per cent. of the copper, and for the manufacture of silicious copper and bronze the proportion of silicium added thereto may be varied from, say, about 0.05 to 12 per cent. In order to obtain 12 per cent. of silicium in the alloy, I employ about 3 parts of fluosilicate of potass to 10 parts of copper; a smaller quantity of the fluosilicate will give a proportionately smaller percentage of silicium in the alloy.

The sodium compounds hereinbefore described, and which I call sodium-tin and sodium-bronze, although specially intended for use in the manufacture of silicious bronze in the manner explained, may also be used for other purposes.

Having now described the nature of my said invention, and in what manner the same is to be performed, I declare that I claim:—

First—The manufacture, substantially as herein set forth, of the new compounds which I have herein called sodium-tin and sodium-bronze.

Second—The manufacture of silicious-bronze substantially as herein set forth, by introducing one of the compounds which I have herein called respectively sodium-tin and sodium-bronze and fluosilicate of potass, with or without an amount of uncombined sodium, into melted copper or bronze.

Third—The manufacture of silicious-bronze, substantially as herein set forth, by introducing the metal sodium and fluosilicate of potass, with or without an amount of tin, into melted bronze, or with tin into melted copper.

Fourth—The manufacture of silicious copper, substantially as herein set forth, by introducing the metal sodium and fluosilicate of potass into melted copper.



---

*Improvements in the Manufacture of Silicious Copper and Silicious Bronze.*

---

In witness whereof, I, the said Lazare Weiller, have hereunto set my hand and seal, this fourth day of July, one thousand eight hundred and eighty-three.

L. WEILLER.

This is the specification referred to in the annexed Letters of Registration granted to Lazare Weiller, this eleventh day of October, A.D. 1883.

AUGUSTUS LOFTUS.

---

**REPORT.**

---

Sir,

Sydney, 4 September, 1883.

We do ourselves the honor to report, in reply to your blank cover of the 24th ultimo, No. 10,755, transmitting the Petition of Lazare Weiller for the registration of an invention entitled "Improvements in the Manufacture of Silicious Copper and Silicious Bronze, and the preparation of certain compounds suitable to be employed in such manufacture," that we are of opinion the prayer of the Petitioner may be granted in terms of specification and claim.

We have, &c.,

E. C. CRACKNELL.

GOTHER K. MANN.

The Under Secretary of Justice.

---

**No. 1327.**

[Assignment of No. 652. See Letters of Registration for 1878, page 1.]

---

**No. 1328.**

[Assignment of No. 652. See Letters of Registration for 1878, page 1.]



A.D. 1883, 24th October. No. 1329.

IMPROVEMENTS IN THE MANUFACTURE AND LAYING OF COMPOSITE  
PAVEMENTS, &c.

LETTERS OF REGISTRATION to Peter Stuart, for Improvements in the  
Manufacture and Laying of Composite Pavements, Floors, Platforms, Land-  
ings, Stair-steps, and the like, and in Composition therefor.

[Registered on the 26th day of October, 1883, in pursuance of the Act 16 Vic. No. 24.]

BY HIS EXCELLENCY THE RIGHT HONORABLE SIR AUGUSTUS WILLIAM FREDERICK SPENCER LOFTUS  
(commonly called LORD AUGUSTUS LOFTUS), Knight Grand Cross of the Most Honorable Order of  
the Bath, a Member of Her Majesty's Most Honorable Privy Council, Governor and Commander-in-  
Chief of the Colony of New South Wales and its Dependencies.

TO ALL TO WHOM THESE PRESENTS SHALL COME, greeting:—

WHEREAS PETER STUART, of Edinburgh, in the county of Midlothian, North Britain, composite pavement manufacturer, hath by his Petition humbly represented to me that he is the author or designer of a certain invention or improvement in manufactures, that is to say, of an invention entitled "Improvements in the Manufacture and Laying of Composite Pavements, Floors, Platforms, Landings, Stair-steps, and the like, and in Composition therefor," which is more particularly described in the specification and the sheet of drawings which are hereunto annexed; and that he, the said Petitioner, hath deposited with the Honorable the Treasurer of the said Colony of New South Wales the sum of Twenty Pounds sterling for defraying the expense of granting these Letters of Registration, as required by the Act of Council, sixteenth Victoria, number twenty-four; and hath humbly prayed that I would be pleased to grant Letters of Registration, whereby the exclusive enjoyment and advantage of the said invention or improvement might be secured to him for a period of fourteen years: And I, being willing to give encouragement to all inventions and improvements in the arts or manufactures which may be for the public good, and having received a report favourable to the prayer of the said Petition, from competent persons appointed by me to examine and consider the matters stated therein, and to report thereon for my information, am pleased, with the advice of the Executive Council, and in exercise of the power and authority given to me by the said Act of Council, to grant, and do by these Letters of Registration grant unto the said Peter Stuart, his executors, administrators, and assigns, the exclusive enjoyment and advantage of the said invention or improvement, for and during the term of fourteen years from the date hereof; to have, hold, and exercise unto the said Peter Stuart, his executors, administrators, and assigns, the exclusive enjoyment and advantage thereof, for and during and unto the full end and term of fourteen years from the date of these presents next and immediately ensuing, and fully to be complete and ended: Provided always, that if the said Peter Stuart shall not, within three days after the granting of these Letters of Registration, register the same in the proper office in the Supreme Court, at Sydney, in the said Colony of New South Wales, then these Letters of Registration, and all advantages whatsoever hereby granted, shall cease and become void.

In witness whereof, I have hereunto set my sign manual, and have caused the present Letters of Registration to be sealed with the seal of the said Colony of New South Wales, at Government House, Sydney, in New South Wales, this twenty-fourth day of October, in the year of our Lord one thousand eight hundred and eighty-three.

[L.s.]

AUGUSTUS LOFTUS.

*Improvements in the Manufacture and Laying of Composite Pavements, &c.*

SPECIFICATION of PETER STUART, of Edinburgh, in the county of Midlothian, North Britain, composite pavement manufacturer, for an invention entitled "Improvements in the Manufacture and Laying of Composite Pavements, Floors, Platforms, Landings, Stair-steps, and the like, and in Composition therefor."

THIS invention relates to the manufacture and laying of composite street pavements, floors, platforms, landings, stair-steps, and the like.

In the manufacture of composite pavements, containing a proportion of cement and of broken or granulated rock, it has hitherto been customary to use the ordinary Portland, Roman, or similar cement of commerce, in combination with whatever stones were available in the locality, and to finish off with a wearing surface composition of sand and cement. Owing to the unreliable character of the materials used, it has been found that the pavements have been rendered subject to expansion and contraction, and have cracked or fissured, and otherwise been seriously affected by atmospheric influences, and have worn unevenly on the surface.

Under this invention, to obviate these defects, and to produce a pavement which will stand a much higher breaking strain, and be more solid and durable, as well as wear more evenly on the upper or wearing surface, I specially select the materials I employ; and first, I preferably employ a cement of the first quality, obtained by carefully selecting and grinding only such of the admixed clay and chalk as has been thoroughly calcined, and rejecting such as has not been so completely incinerated in the process of manufacture. Second—With the cement I mix crushed granite, because I find that there is a particular affinity between granite and cement, due to the absorbent and binding action of the mica present in the granite; and with the object of clearing the faces of the crystals, and exposing the laminae of the mica to the action of the cement, I carefully remove the fine dust or flour resulting from the crushing operation, either by sifting, washing, or otherwise. As previously stated, I thereby find that the breaking and crushing strain and the durability of the pavement is greatly increased.

In the improved pavement this composition constitutes the wearing surface, and I apply it on the top of the layer of ordinary concrete usually employed in laying composite pavements, instead of the composition of cement and sand, smoothed, floated, or trowelled into the surface, as hitherto practised.

In laying a pavement according to this invention, the ground is first excavated to a depth of 7 inches, or other depth, according to the strength required, or nature of the ground. A layer of stone or other equivalent material, broken or sized to pass through a 2½-in. ring, and free from sand or other earthy matter, is spread level in the excavation to a depth of 4 inches or thereby, and the bed of stones is then divided or measured off into squares according to the size of slabs it is desired to produce, every alternate square being laid as hereinafter described. A layer of ordinary concrete is laid to a depth of 2 inches, or other depth, according to the strength required, on alternate squares of stones, both as regards the length and breadth of the pavement. The concrete is then levelled with a straight-edge, and thereafter it is rolled or beat flat, and compressed by a heavy roller or beater of ordinary construction.

Bars or rods of wood are then laid on the top of the concrete around the four sides of each square, and, if the paving is for outside purposes, V or other shaped grooves are made on the surface, parallel to the wooden rods, at two sides of the square, by means of a flat metal plate having a projection on its under surface corresponding to the shape of the groove, or the groove may be formed by hand or otherwise. By preference, I make these grooves from 4 to 6 inches from the side of the square.

In each groove an iron rod, preferably rectangular, is laid with its upper edge level with the surface of the concrete, and other iron rods are laid on the surface of the concrete at right angles to the rods first mentioned. At the points of intersection the two sets of rods are secured together with wire, or equivalent means, and the ends of the rods project beyond the points of intersection. When kerbs are formed the rods in the grooves extend into them, and an iron rod is laid along the centre of the kerb and fastened to the other rods, as before set forth. Galvanized iron or other wires placed at suitable distances apart are, or may also be, stretched across the squares formed by the two sets of rods, to afford additional strength.

In the space enclosed by the rods, and on the surface of the concrete, the hereinbefore specified improved composition of granite and cement is laid to a thickness of 2 inches, or other thickness corresponding to the strength of pavement required.

The composition is spread so as to embed the iron rods, and it is then levelled with a straight-edge bearing on the wooden rods hereinbefore referred to, and thereafter tapped solid in the usual manner, after which it is polished on the surface, and, if desired, indented by means of a roller, and afterwards crossed by a sharp-pointed tool into diamond or other shaped slabs.

When the alternate squares have set sufficiently hard the wooden bars or rods are removed from around them, and the projecting under layer of concrete is then cut straight down flush with the granite composition, and the other alternate or intermediate squares of stones are then covered first with ordinary concrete and then with improved granite composition, as hereinbefore described. When the whole pavement has set, the surface is, or may be, painted over with a coating of silicate of soda or clear water; and if it is desired to colour the surface, ground or pulverised hematite or other iron ore or colouring matter may be mixed with the silicate of soda. By this method of laying each square sets separately, and the joint between each square enables the squares to expand or contract under atmospheric influences without risk of cracking the slabs.

In making the improved paving composition hereinbefore described, and which I call "Granolithic," the granite is cubed by ordinary crushing machinery to a size of ½ in. and under, and freed from the flour or dust resulting from the granulating process. It is next mixed with the Portland or other cement, and the mixture is then sifted through a ⅓-in. sieve, after which the components are thoroughly amalgamated in a steam or hand pug-mill or by hand labour, a sufficient quantity of water being added to the mixture to render the whole plastic. The constituents may be amalgamated in various proportions. I have obtained good results with two parts of granite to from one to one and a quarter parts of cement, and with three parts of granite to one of cement.

On

*Improvements in the Manufacture and Laying of Composite Pavements, &c.*

On the accompanying drawings, figure 1 is a diagram plan, and figure 2 a vertical section showing the method of laying the pavement in accordance with my said invention.

*b* are the wooden battens or rods laid around the alternate squares of concrete, *a*. *c* are the V-shaped grooves cut in the surface of the concrete, and in each groove an iron bar or rod, *d*, preferably rectangular, is laid with its upper edge level with the surface of the concrete. Other rectangular rods, *e*, are laid on the surface of the concrete at right angles to the rods *d*, and where the rods *d* and *e* cross they are tied together by wire or other equivalent means.

When the paving is for inside purposes the grooves *c* and rods *d* and *e* are or may be dispensed with.

When kerbs and water channels are to be formed along with the pavement, wooden boarding is fixed to the line of the kerb before laying the concrete, and the rods, *d*, situated in the grooves extend into the kerb, whilst another rod, fastened on top of the rods *d* by wire or its equivalent, extends along the centre of the kerb. These rods constitute binding and strengthening beams or stays for the pavement. Instead of embedding one set of them in grooves, as before set forth, both sets may be laid on the surface of the concrete, and additional strength may further be given to the pavement by extending a series of galvanized or ordinary iron wires from one side to the other of the squares formed by the rods on each slab.

Instead of laying the improved "granolithic" composition in a plastic state *in situ*, as hereinbefore described, it may be moulded into flags or slabs in separate moulds, with the iron bars or rods embedded or not in such flags or slabs as desired, and, when hardened or set, removed from the moulds and placed in position after the manner of laying ordinary stone paving. The improved composition, besides being used in laying pavements, floors, and platforms, may also be employed in the manufacture of stair-steps, landings, and like structures, by also moulding it in moulds suitably shaped for the purpose. In this way glass may be inserted in the paving when the slabs are to be used for covering cellars or other underground structures. The moulds for the slabs are placed on a table, which is vibrated or shaken so as to pack the granolithic in the moulds, such vibration being effected by any suitable mechanical means.

Having now described the nature of my said invention, what I desire to claim and secure by Letters of Registration is—

First—Combining *carefully selected cement* with crushed or cubed *granite* from which all flour or dust has been removed, to form "Granolithic" or a wearing surface for composite pavements, substantially in the proportions and as herein described and explained.

Second—A composite pavement formed by a layer or bed of stones and a layer of concrete, upon which the "Granolithic," or wearing surface composition, is laid *in situ* in a plastic or moulded state, and with or without strengthening iron rods or wires within or above the concrete, substantially as herein described and explained.

In witness whereof, I, the said Peter Stuart, have hereto set my hand.

P. STUART,  
(By his Agent, EDWD. WATERS).

This is the specification referred to in the annexed Letters of Registration granted to Peter Stuart, this twenty-fourth day of October, A.D. 1883.

AUGUSTUS LOFTUS.

## REPORTS.

Sir,

Sydney, 26 February, 1883.  
With reference to your communication of the 9th instant, instructing us to report on an application of Peter Stuart, of Edinburgh, for protection of an invention entitled "Improvements in the Manufacture and Laying of Composite Pavements, Floors, Platforms, Landings, and Stair-steps," we are of opinion that Letters of Registration should not be issued, as the invention is not sufficiently novel.

We have, &c.,

JAMES BARNET.  
W. C. BENNETT.

The Under Secretary of Justice.

Sir,

Sydney, 18 April, 1883.  
With reference to your B.C. minute of the 16th March, enclosing Mr. Walsh's letter of the 10th March, with respect to Mr. Stuart's application for Letters of Registration for "Improvements in the Laying of Composite Pavements," we have given the question full consideration, and are still of opinion that the application should not be granted.

We have, &c.,

JAMES BARNET.  
W. C. BENNETT.

The Under Secretary of Justice.

Sir,

Sydney, 25 June, 1883.  
In reply to your B.C. minute of the 23rd ultimo, relative to Mr. Stuart's application for protection for "Improvements in Concrete Pavements, &c., and methods of laying same," we have to report that after receiving explanations from applicant, and seeing illustrative photographs, we think the first claim for protection of composition and making of concrete might be conceded; but as the second claim for method of laying has been in use in the Colony for some time, we cannot recommend that it be granted.

We have, &c.,

JAMES BARNET.  
W. C. BENNETT.

The Under Secretary of Justice.

Sir,

---

*Improvements in the Manufacture and Laying of Composite Pavements, &c.*

---

Sir,

Sydney, 17 July, 1883.

Having again reconsidered the question of Mr. Stuart's claim for protection for improvements in concrete pavements, we cannot recommend any further protection than that set forth in our letter of the 25th June, as we are of opinion that, except in the matter of selection of cement, sifting and removal of dust, and laying-in, the invention is in every respect the same as that for which Letters of Registration were issued in favour of Mr. O'Neill, on the 25th May, 1880.

We have, &amp;c.,

JAMES BARNET.

WILLIAM O. BENNETT.

The Under Secretary of Justice.

---

[Drawings—one sheet.]

Fig. 1.

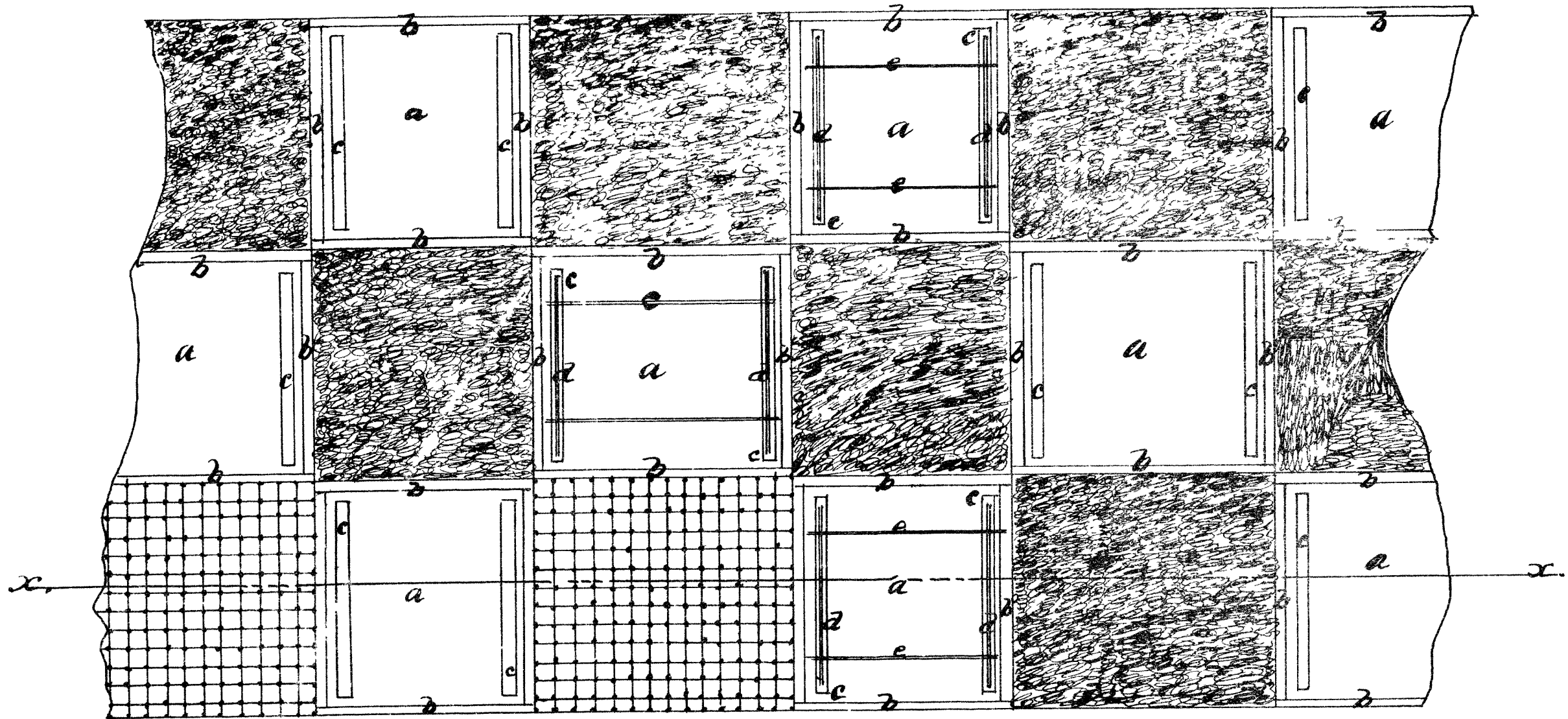
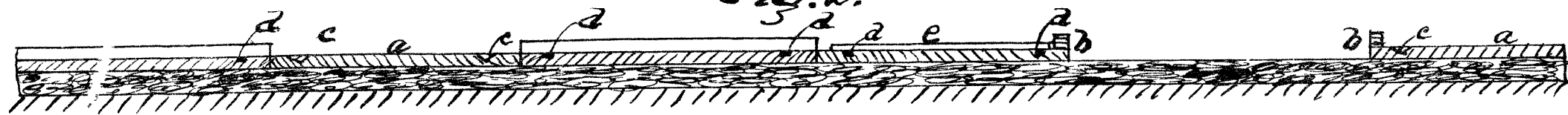


Fig. 2.



Section on line X.X.

This is the Sheet of Drawings referred to in the annexed Letters of  
 Registration granted to Peter Stuart this 24<sup>th</sup> day of October, A.D. 1883.  
 Augustus Loftus.

(sig 35)



A.D. 1883, 25th October. No. 1330.

IMPROVEMENTS IN SEWING MACHINES.

LETTERS OF REGISTRATION to John William Post, for Improvements in Sewing Machines.

[Registered on the 26th day of October, 1883, in pursuance of the Act 16 Vic. No. 24.]

BY HIS EXCELLENCY THE RIGHT HONORABLE SIR AUGUSTUS WILLIAM FREDERICK SPENCER LOFTUS, (commonly called LORD AUGUSTUS LOFTUS), Knight Grand Cross of the Most Honorable Order of the Bath, a Member of Her Majesty's Most Honorable Privy Council, Governor and Commander-in-Chief of the Colony of New South Wales and its Dependencies.

TO ALL TO WHOM THESE PRESENTS SHALL COME, greeting:

WHEREAS JOHN WILLIAM POST, of the city, county, and State of New York, in the United States of America, gentleman, hath by his Petition humbly represented to me that he is the author or designer of a certain invention or improvement in manufactures, that is to say, of an invention entitled "Improvements in Sewing Machines," which is more particularly described in the specification, marked A, and the two sheets of drawings, marked B and C respectively, and which are hereunto annexed; and that he, the said Petitioner, hath deposited with the Honorable the Treasurer of the said Colony of New South Wales the sum of Twenty Pounds sterling, for defraying the expense of granting these Letters of Registration, as required by the Act of Council, sixteenth Victoria, number twenty-four; and hath humbly prayed that I would be pleased to grant Letters of Registration, whereby the exclusive enjoyment and advantage of the said invention or improvement might be secured to him for a period of fourteen years: And I, being willing to give encouragement to all inventions and improvements in the arts or manufactures which may be for the public good, and having received a report favourable to the prayer of the said Petition, from competent persons appointed by me to examine and consider the matters stated therein and to report thereon for my information, am pleased, with the advice of the Executive Council, and in exercise of the power and authority given to me by the said Act of Council, to grant, and do by these Letters of Registration grant unto the said John William Post, his executors, administrators, and assigns, the exclusive enjoyment and advantage of the said invention or improvement, for and during the term of fourteen years from the date hereof; to have, hold, and exercise unto the said John William Post, his executors, administrators, and assigns, the exclusive enjoyment and advantage thereof, for and during and unto the full end and term of fourteen years from the date of these presents next and immediately ensuing, and fully to be complete and ended: Provided always, that if the said John William Post shall not, within three days after the granting of these Letters of Registration, register the same in the proper office in the Supreme Court, at Sydney, in the said Colony of New South Wales, then these Letters of Registration, and all advantages whatsoever hereby granted, shall cease and become void.

In witness whereof, I have hereunto set my sign manual, and have caused the present Letters of Registration to be sealed with the seal of the said Colony of New South Wales, at Government House, Sydney, in New South Wales, this twenty-fifth day of October, in the year of our Lord one thousand eight hundred and eighty-three.

[L.S.]

AUGUSTUS LOFTUS.

*Improvements in Sewing Machines.*

## A.

TO ALL TO WHOM IT MAY CONCERN: BE it known that I, John William Post, of the city, county, and State of New York, in the United States of America, am in possession of an invention for Improvements in Sewing Machines; and I, the said John William Post, do hereby declare the nature of the said invention, and in what manner the same is to be performed, to be particularly described and ascertained in and by the following statement thereof, that is to say:—

THE object of this invention is to produce a sewing machine which shall be free from irregular motions, and which shall be capable of forming a lock-stitch or the chain-stitch, and the number of parts of which the machine is composed is greatly lessened, and which is easily operated and substantially noiseless in its functions.

The invention consists essentially in the improvements which I shall hereinafter fully describe, and which are shown in the accompanying drawings, in which figure 1 is a side elevation, and figure 2 a bottom plan view of a machine provided with my improvements; figure 3 is a longitudinal section of the same; figure 4 is a cross-section on an enlarged scale in line  $x x$ , figure 2, with the looper removed; figure 5 is a partly sectional front elevation of the feed-plate and connecting parts; figures 6 and 7 are cross-sections in lines  $x x$  and  $y y$ , figure 4, respectively; figure 8 is a partly sectional front elevation; figure 9 is a vertical cross-section in line  $y y$ , figure 3, looking forward; figure 10 is a front elevation of the face-plate at the head of the machine; figure 11 is a horizontal section on an enlarged scale in line  $x x$ , figure 8; figure 12 is a top plan view of the upper end of the guide of the needle-bar; figures 13 and 14 are horizontal sections in lines  $x x$  and  $y y$ , figure 1, respectively; figure 15 is a side elevation of the needle guard; figure 16 is a longitudinal section of the lock-stitch mechanism on an enlarged scale; figure 17 is a front elevation of the needle-bar and lock-stitch mechanism, showing the parts in the position in which the hook of the revolving looper seizes the loop; figure 18 is a front elevation of the same parts, showing the same in the position in which the needle thread is drawn off to its greatest length; figure 19 is a similar front elevation, showing the loop drawn off the hook of the looper; figures 20, 21, and 22 are vertical longitudinal sections of the upper portion of the needle-bar and guide, corresponding respectively with figures 17, 18, and 19; figure 23 is a partly sectional top plan view of the lock-stitch mechanism and connecting parts on an enlarged scale; figure 24 is a horizontal section of the same parts; figure 25 is a front elevation of the revolving looper; figure 26 is a side elevation of the same; figure 27 is a front elevation of the spool-holder; figures 28 and 29 are vertical sections of the spool-holder, at right angles to each other; figure 30 is a rear elevation of the arm bearing against the front side of the spool-holder.

Like letters of reference refer to like parts in the several figures.

A is the bed or base plate of the machine, A<sup>1</sup> the standard, A<sup>2</sup> the arm extending forwardly from the upper end of the standard, and A<sup>3</sup> the head-block, arranged in a well-known manner, with the exception that the body of the standard A<sup>1</sup> and the arm A<sup>2</sup> are made round in cross-section, so that it can be readily turned off and prepared for the operation of plating, thereby doing away with the great amount of manual labour otherwise required for finishing these parts.

$a$  is the horizontal driving shaft in the arm A<sup>2</sup>, and provided at its front end with a crank disc,  $a^1$ , by which the needle-bar  $a^2$  is operated.  $a^3$  is a connecting-rod connected to the crank-pin of the disc  $a^1$ , and to a cross-head and sleeve,  $a^4$ , respectively. The sleeve is secured to the needle-bar  $a^2$  by set screws (see figures 3 and 8), or in any other manner. The needle-bar  $a^2$  is guided at the upper end of the head A<sup>3</sup> in a cylindrical bearing,  $a^5$ , and at the lower end thereof in a similar bearing,  $a^6$ .

$a^8$  and  $a^7$  represent the presser-foot and its bar or rod respectively. The bar  $a^7$  is also guided in the top and bottom of the head-block A<sup>3</sup>. The cross-head  $a^4$  surrounds the needle-bar  $a^2$ , and is provided at the side adjacent to the presser-foot bar  $a^7$  with a semi-cylindrical bearing surface which bears against the inner side of said bar  $a^7$ , and serves to guide the cross-head on the same, thereby giving the needle bar a bearing intermediate between the top and bottom portions of the head-block A<sup>3</sup>.

The cross-head  $a^4$  is readily constructed by forming a cross-head twice as long as necessary, and drilling three holes through the same at equal distances apart, and then driving the cross-head centrally through the middle opening, whereby two cross-heads of similar form will be formed.

A<sup>4</sup> is the face-plate of the head-block A<sup>3</sup>. This face-plate is provided with an opening,  $a^9$ , which is covered by a glass,  $a^{10}$ , placed opposite the crank disc  $a^1$ , so that the head motion can be observed through this glass, thus facilitating the application of oil and the taking up of lost motion through an opening in one of the side walls of the head-block A<sup>3</sup>.

$b$  is the needle secured to the lower end of the needle-bar  $a^2$  in any well-known or desired manner.  $b^1$  represents a shield or guard which is arranged in front of the needle so as to hide the needle-bar from the view of the operator, to relieve the eyes from the unpleasant sensation and dazzling effect caused by the rapid reciprocation of said bar. The shield may be secured to the head-block A<sup>3</sup> by a shank,  $b^2$ , inserted in an opening in the head-frame, and secured therein by a set screw,  $b^3$ , the shield being pivoted to the shank  $b^2$ , by a hinge,  $b^4$ , so that the shield can be swung out of the way to expose the needle when necessary to thread it, or for other purposes. The shield  $b^1$  also protects the needle against breakage by preventing obstructions from coming in contact therewith from the side on which the guard is arranged, the other side being protected by the presser-foot.

$c$  is the spool-post secured to the standard A<sup>1</sup>, and  $c^1$  is the spool thereon.  $d$  is the tension disc arranged on one side of the needle-bar guide D, at the upper end of the head-block A<sup>3</sup>, and  $a^1$  is a spring that presses the disc  $d$  against the flat side of the needle-bar guide D. The spring  $a^1$  is preferably a long flat spring, secured at its lower end to the inner side of one of the side walls of the head-block A<sup>3</sup>, and made adjustable near its upper end by a set screw,  $a^2$  (see figure 8). The great length of the spring permits of a very fine adjustment of the pressure against the tension disc  $d$ .

$e$  is a vertical slot or mortise formed in the needle-bar guide D on its front side, and extending preferably from the top plate of the head-block A<sup>3</sup> to the upper end of the needle-bar guide.  $f$  is a projection formed on the front side of the needle-bar  $a^2$ , near its upper end, and playing in the mortise  $e$ . The projection  $f$  has in its upper surface a depression or groove,  $f^1$ , in which the thread rests when the needle



*Improvements in Sewing Machines.*

needle-bar rises and completes the stitch in sewing the chain-stitch. The front side of the projection is made inclined forwardly, and the front side of the needle-bar guide D is also inclined forwardly, as shown at  $f^2$  on both sides of the mortise  $e$ . The inclined front portion of the needle-bar guide D projects further forward than the projection  $f$  on the needle-bar, so that as the projection ascends between the inclined portions of the guide D the latter will draw forward the thread which rests against the under side of the projection  $f$  in sewing the lock-stitch, and will finally withdraw the thread from under said projection, and release it therefrom.

The needle-bar guide D has a collar,  $g$ , above the tension disc  $d$  that extends beyond the mortise  $e$ , which latter extends through this collar.  $g^1$  and  $g^2$  are notches formed in the collar  $g$  on opposite sides of the mortise  $e$ . The notch  $g^2$  has a tension bolt,  $g^3$ , arranged in a socket in the collar  $g$ , and provided with a tension spring,  $g^4$ , which can be adjusted by means of a screw,  $g^5$ , whereby the thread is steadied or held against any flopping movement.

In sewing the chain-stitch the thread runs from the spool  $c^1$  to the tension disc  $d$ , thence upwards through the notch  $g^1$ , thence across the upper side of the collar  $g$  and the notch in front of the needle-bar to the notch  $g^2$ , thence downward and through a guide eye,  $h$ , on the front side of the needle-bar guide D, and thence downward through the eye of the needle, as shown in figures 1 and 8.

In sewing the lock-stitch the thread runs from the tension disc  $d$  over a horizontal loop,  $h^1$ , arranged on the front side of the needle-bar guide D, below the collar  $g$ , and thence downward to the guide  $h$  and the eye of the needle, as shown in figures 17, 18, and 19.

The looper and feed mechanism are actuated by a horizontal shaft,  $i$ , supported in suitable bearings,  $i^1$ , formed on the under side of the bed-plate A. Motion is imparted to the shaft  $i$  from the driving shaft  $a$  by an eccentric,  $i^2$ , on shaft  $a$ , and an eccentric rod,  $i^3$ , connected at its lower end to a crank disc,  $i^4$ , mounted on the end of the shaft  $i$ . The eccentric rod  $i^3$  rocks on a fulcrum pin,  $i^5$ , secured to the standard A<sup>1</sup>.

$j$  is an opening formed in the front wall of the upper portion of the standard, provided with a removable cover,  $j^1$ , which can be taken off for oiling and adjusting the eccentric  $i^2$  and the eccentric rod attached thereto.

K is the rotating looper employed for forming the chain-stitch. The looper K has a shank,  $k$ , which is inserted in a socket,  $k^1$ , formed in the shaft  $i$  and secured thereto by a set screw,  $k^2$ , having a suitable handle, and engaging in a groove or against the flattened side of the inner portion of the shank  $k$ , so that the looper can be readily secured in place and removed as may be required.

$l$  represents an eccentric neck formed at the front end of the shaft  $i$  for actuating the feed-bar L. The eccentric  $l$  is made smaller in diameter than the shaft  $i$ , and engages in an elongated opening,  $l^1$ , formed in the feed-bar L. The latter is provided with the usual serrated surface,  $l^2$ , which projects upward through an opening,  $l^3$ , in the bed-plate A.

In the rear end of the feed-bar is formed a notch,  $l^4$ , and  $l^5$  is a horizontal bolt in a casting,  $m$ , formed on the under side of the bed-plate A. The bolt  $l^5$  extends through the notch  $l^4$  in the feed-bar, and supports the rear end thereof. The opening  $l^1$  in which the eccentric  $l$  works is bushed with a metallic split ring,  $l^6$ , conforming to the contour of opening  $l^1$ , and one or more screws,  $l^7$ , pass through the feed-bar L, and impinge against the bushing  $l^6$ , as shown at figure 5, whereby any wear of the eccentric or bushing may be taken up or compensated for by the contraction of the bushing through the medium of the screws  $l^7$  in an obvious manner.

An adjustable wedge, M, is arranged on the under side of the bed-plate A, between the rear end of the feed-bar L and the depending side flanges  $m^1$  on the bed-plate A. When the feed-bar L has been retracted it rests with its rear end against the wedge M, as shown on figure 5. By adjusting the wedge M in one or the other direction the feed-bar can be moved forward or backward, thereby changing the starting point, and reducing or increasing the throw of said bar and the length of the stitch.

A spiral or other suitable spring,  $m^2$ , is interposed between a shoulder on the casting  $m$  and a shoulder near the rear end of the feed-bar, so as to press the feed-bar backward. The rotation of the eccentric  $l$  effects the forward movement of the feed-bar, during which the spring  $m^2$  is compressed, and the reaction of the spring effects the return movement of the feed-bar.

The wedge M is provided with a rod,  $m^3$ , extending along the lower side of the bed-plate A, said rod having at its rear end a bolt,  $m^4$ , which extends through a slot,  $m^5$ , in the bed-plate, the bolt being clamped in any desired position by a thumb-nut,  $m^6$ . The wedge M is adjusted by moving the bolt  $m^4$  in one or the other direction in the slot  $m^5$ .

On the under side of the bed-plate A, in front of the looper K, is arranged a plate, N, that serves to confine the outer portion of the loop of the needle thread, causing it to be thrown off on the inner side of said needle, where it can be seized by the hook of the looper K.

The plate N is mounted upon the end of a lever,  $n$ , which is pivoted at  $n^1$  to the under side of the bed-plate A, and is provided at its opposite end with a thumb-piece,  $n^2$ , for conveniently taking hold of it. The lever  $n$  is made sufficiently elastic to permit it to be locked in position by the engagement of a small stud or protuberance,  $n^3$ , on the under side of the bed-plate in corresponding openings in the end of the lever  $n$ . The plate N can be readily swung away from the looper K when the latter is to be removed from the shaft  $i$ .

O represents the disc of the looper which is employed in sewing the lock-stitch, and which is provided with a shank,  $o^1$ , constructed in all respects like the shank  $k$  hereinbefore described, which is formed on the looper K, and whereby the disc O is secured to the shaft  $i$ . The disc O is provided on its face side with a concave depression,  $o^2$ , in which the convex rear side of the spool-holder P is seated.

A hook,  $o^3$ , formed on the face of the disc O, takes the loop from the needle, and a curved arm,  $o^4$ , is secured to the face side of the disc O, and arranged in front of the hook  $o^3$ , with its face end near the point of said hook  $o^3$ , as clearly represented in figures 25 and 26. The spool-holder P is constructed with a convex rear side, and a V-shaped annular edge surrounding its open front. The spool  $p$  is constructed with convex inner and outer sides or discs,  $p^1$   $p^2$ , and turning on a hollow arbor,  $p^3$ , which is secured to the rear wall of the spool-holder P.

An annular frame, Q, bears against the front side of the spool-holder P, and confines the latter in the concave depression of the disc O. The holder P has a lip or projection,  $p^4$ , which engages in a notch,  $q$ , formed in the annular frame Q, whereby the spool-holder is prevented from turning in the disc O.

Through

*Improvements in Sewing Machines.*

Through an opening or recess,  $p^5$ , in the peripheral wall of the spool-holder, the thread is drawn, and a wire or bar,  $p^6$ , is arranged in said opening or recess, to give tension to the thread by winding the thread around said bar, as represented in figure 28. A spring,  $q^2$ , or yielding arm is secured to the shank  $q^3$  of the frame Q, and bears against the front side of the spool with sufficient force to retain the spool in its proper position, and at the same time permit it to turn as the thread is drawn off. The shank  $q^3$  of the frame Q is attached to a bracket, R, depending from the base plate A of the machine by a bolt,  $r$ , which is seated in a socket in the bracket R, and has at its inner end a notch forming a hook,  $r^1$ , which can be engaged behind a transverse bolt,  $r^2$ , secured in said bracket, and intersecting the socket in which the bolt  $r$  is seated, so that by giving the bolt  $r$  a quarter turn in one or the other direction by means of the handle  $r^3$  the bolt is locked or unlocked, and the annular frame Q attached or released, as may be desired.

While I have shown a desirable means of securing the frame or holder in place, as just described, it will be apparent that changes may be made in this particular without departing from the spirit of my invention, so long as the idea is preserved of securing the frame or holder in place by a partial rotation only of the locking device, such for instance as that known as a "bayonet joint."

Upon removing the annular frame Q, the spool-holder P and the disc O can be removed from the shaft  $z$ , and the looper K substituted for the same. It will be observed that the shanks  $k$  and  $o^1$  of the loopers K and O respectively are each formed with a flattened side, which is so arranged that when the screw  $k^2$  projects slightly within the socket  $k^1$ , said shanks can only be inserted when their flattened sides are turned towards said screw. These flattened sides are so arranged axially relative to the hooks of the loopers as to insure the setting of said loopers in their proper operative positions without any special care on the part of the operator.

In sewing the lock-stitch the looper spool-holder P and annular frame Q are arranged in position, as represented in figure 17. The loop thrown off by the needle is seized by the hook  $o^3$  of the looper, and during the rotation of the latter in the direction of the arrow in figure 17 the loop is gradually enlarged and carried onward, the outer portion of the loop passing between the front side of the spool-holder P and the frame Q, and the rear side of the loop passing between the rear side of the spool-holder P and the disc O, until the parts reach the position represented in figure 18.

When the descending movement of the needle-bar begins the projection  $f$  at the upper end of the needle-bar begins to depress that portion of the thread which extends across the loop  $h^1$ , and the continuation of this movement of the projection  $f$  draws the loop from the hook  $o^3$  of the looper, as represented in figure 19. In this manner the needle thread is looped around the thread coming from the spool in the spool-holder P.

The curved arm  $o^4$  is located in close proximity to the front side of the needle, and prevents the loop of the needle thread from being thrown off on the front side of the needle, but compels it to be formed on the rear side in the path of the hook  $o^3$ . Said arm  $o^4$  also serves to keep the loop of the needle thread which has been drawn from the hook  $o^3$  out of the way of said hook until it has been drawn up and tightened by the formation and enlargement of the next succeeding loop.

The front plate of the spool  $p$  is provided with one or more openings,  $s$ , through which the amount of thread contained on the spool can be observed without removing any part of the mechanism.

My improved machine is free from irregular motions, and is therefore easily operated with very little effort at a high rate of speed, and its operative parts move with very little noise. The machine can be readily adapted to sew either a chain or lock stitch without requiring the use of either a screw-driver or a wrench for this purpose.

By avoiding the use of an independent take-up for taking up slack loops, and by paying the thread for each successive stitch directly from the spool, and drawing it tight only at the point of finishing each stitch, the friction on the thread is greatly reduced, and the liability of the thread being broken considerably lessened.

As a very light tension is sufficient, the wear on the thread is avoided, and the seam accordingly strengthened.

It will be observed that instead of using the rotary looper described for making the lock-stitch, a rotary shuttle could be employed by making only such changes as would be apparent to any one skilled in the art, the gist of my invention in this particular consisting in the generic idea of employing interchangeable rotary devices for forming the two kinds of stitches.

It will be understood that what is meant by the interchangeability of the devices designed to be secured to the end of the rotary shaft beneath the bed-plate is, that both are so organized and constructed as to be attached to, and removed from, the end of the shaft, and that each is removed to make place for the other in converting the machine from a lock-stitch to a chain-stitch, and *vice versa*.

What I claim as new is,—

First—The combination in a sewing machine, with a needle and its operating mechanism, of interchangeable rotary devices co-operating with said needle to form different kinds of stitches, substantially as set forth.

Second—The combination in a sewing machine, with a needle and its operating mechanism, of interchangeable rotary devices co-operating with said needle in forming different kinds of stitches, said interchangeable rotary devices being both constructed to operate on the same side of the needle, substantially as set forth.

Third—The combination in a sewing machine of a needle and its operating mechanism, a revolving shaft, provided at its front end with suitable means of attachment, and interchangeable rotary devices for forming different kinds of stitches adapted to be secured to said shaft, the said interchangeable devices being so constructed that when seated on the end of the shaft their proper adjustment relatively to the needle is secured, substantially as set forth.

Fourth—

*Improvements in Sewing Machines.*

- Fourth—The combination in a sewing machine, with a needle and its operating mechanism, of interchangeable rotary advices, adapted to co-operate with said needle in forming different kinds of stitches, and a thread-controlling mechanism adapted to co-act with either of said interchangeable devices in forming said different kinds of stitches, substantially as set forth.
- Fifth—The combination in a sewing machine of interchangeable rotary lock- and chain-stitch loopers and a thread-controlling mechanism adapted to draw the thread from the hook of the lock-stitch looper at the proper moment, or to serve as a take-up in connection with the chain-stitch looper accordingly, as one or the other of the loopers is used, substantially as set forth.
- Sixth—The combination in a sewing machine of a needle-operating mechanism arranged above the bed-plate, a rotary shaft arranged beneath the bed-plate, and rotary devices, adapted to be interchangeably secured to, or carried by, said shaft for co-operating with the needle in forming either lock or chain stitches, substantially as set forth.
- Seventh—The combination with a reciprocating needle bar and a revolving shaft, provided at its front end with suitable means of attachment, of the lock- and chain-stitch loopers, adapted to be interchangeably secured to said revolving shaft, substantially as and for the purposes set forth.
- Eighth—In a convertible sewing machine adapted for use, with either a revolving chain-stitch looper or a revolving lock-stitch looper, the rotary shaft provided with an axial slot or socket, K<sup>1</sup>, and a set screw, K<sup>2</sup>, the latter projecting slightly within said socket, in combination with the looper shanks, provided at their ends with a grooved or flattened surface, whereby the proper adjustment of said loopers with reference to the needle is secured, as hereinbefore set forth.
- Ninth—The combination in a sewing machine of a rotary driving shaft arranged above the bed-plate, a needle-bar connected with and operated by said driving shaft, a counter rotary shaft arranged beneath the bed-plate mechanism for operating said counter shaft from said driving shaft, and interchangeable rotary devices adapted to be carried by or secured to said counter shaft for co-operating with the needle in forming either lock or chain stitches at the will of the operator, substantially as set forth.
- Tenth—The combination in a sewing machine, with a needle and its operating mechanism, of a rotary device adapted to press slightly against the side of said needle when it descends below the work plate, to insure the formation of loops of needle thread, and a rotary device co-operating with said needle in forming the stitches for seizing and expanding said loops, substantially as set forth.
- Eleventh—The combination, with the revolving chain-stitch looper, of a reciprocating needle-bar, provided with a projection which raises the thread and draws it tight in finishing the stitch, and a mortised needle-bar guide in which the needle-bar projection plays, as set forth.
- Twelfth—The combination, with a revolving lock-stitch looper and spool-holder, of a reciprocating needle-bar, constructed with a projection which depresses the thread and draws the loop from the hook of the looper, as set forth.
- Thirteenth—The construction and arrangement of the mechanism for operating the needle-bar from the main driving shaft and their combination with the presser-foot to produce the results described, as specified.
- Fourteenth—A screen or shield to cover the needle-bar from view or expose the same to view, and its combination with the head-block to which it is removably connected, in the manner substantially as specified.
- Fifteenth—The mortised needle-bar guide, in combination with a needle-bar having a front projection operating in the mortise of the guide, constructed as described, for the purposes set forth.
- Sixteenth—The combination, with the mortised needle-bar guide and a collar having thread notches as described, of a needle-bar provided with a projection having a depression in its upper side, substantially as set forth.
- Seventeenth—The combination, with a mortised needle-bar guide, of a tension disc, a guide, a loop extending across said mortise, and a needle-bar provided with a front projection, for the purposes set forth.
- Eighteenth—The means for steadying the thread, consisting of a spring bolt in combination with the notched collar, as described.
- Nineteenth—The means, substantially as shown and described, for regulating the tension of the thread, consisting of a leaf-spring and its arrangement on and combination with the head-block and tension disc, as described.
- Twentieth—The peculiar construction and combination of operating mechanism for the feed-bar, and the means provided for compensating the wear of said part by means of the split bushing, as described and shown.
- Twenty-first—The combination, with the lower driving shaft, of the lock-stitch looper secured thereto, and constructed with a hook and curved arms, a spool-holder seated in the front side of the looper, and an annular frame bearing against the front side of the spool-holder, for the purposes set forth.
- Twenty-second—The combination, with the lock-stitch looper, spool-holder, and spool, of an annular frame attached to a depending bracket by a bolt having a hook end, and adapted to engage behind a transverse bolt, and provided with an operating handle, for the purposes as shown and described.
- Twenty-third—The combination, with a removable holder for sustaining the bobbin that carries the lower thread, of mechanism constructed to secure said holder to its support, or detach it therefrom by a partial rotation only, substantially as set forth.
- Twenty-fourth—

*Improvements in Sewing Machines.*

- Twenty-fourth—The mechanism for confining the spool-holder in place, in combination with a rotary bolt adapted to be locked and unlocked by a quarter turn of said bolt, as shown and described.
- Twenty-fifth—A spool-holder, provided with a spool and an opening or recess through which the thread passes from the spool, and a bar arranged in said opening or recess, around which the thread is wound for giving tension to the same, substantially as set forth.
- Twenty-sixth—In a sewing machine, a head-block constructed with a transparent face-plate, through which the head motion can be observed, substantially as set forth.
- Twenty-seventh—The combination, with the revolving chain-stitch looper, of a removable plate arranged in front of the looper, whereby the thread is confined, and the loop prevented from being thrown out on the front side of the needle, substantially as set forth.
- Twenty-eighth—The revolving lock-stitch looper, provided with a curved arm, constructed as described and arranged relatively, as set forth, to the hook, and the plane in which the needle moved, whereby the loop drawn from the hook is kept out of the way of the same, and the succeeding loop formed by the needle is prevented from being thrown out or formed on the front side, substantially as shown and described.

Signed this 16th day of July, 1883.

This is the specification marked A referred to in the annexed Letters of Registration granted to John William Post, the 25th day of October, A.D. 1883.

AUGUSTUS LOFTUS.

---

REPORT.

---

Sir,

We do ourselves the honor to report, in reply to your blank cover of 31st ultimo, No. 10,988, transmitting Mr. John William Post's Petition for the registration of "Improvements in Sewing Machines," that we are of opinion the prayer of the Petitioner may be granted, in terms of his specification, drawings, and claim.

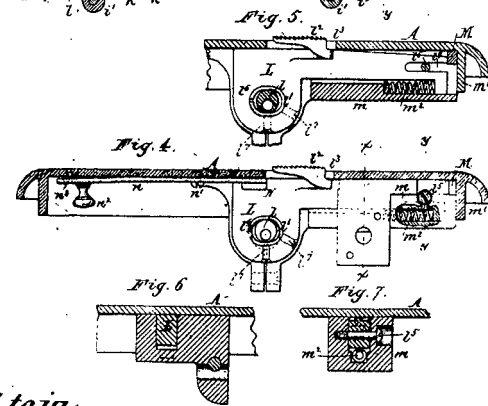
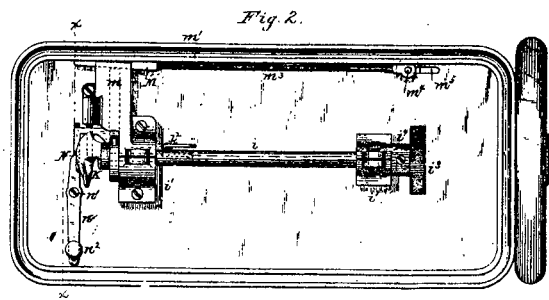
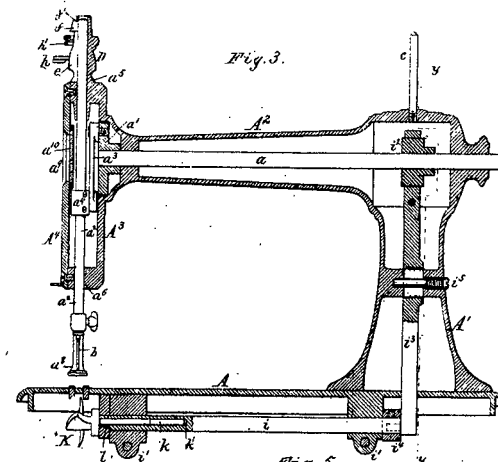
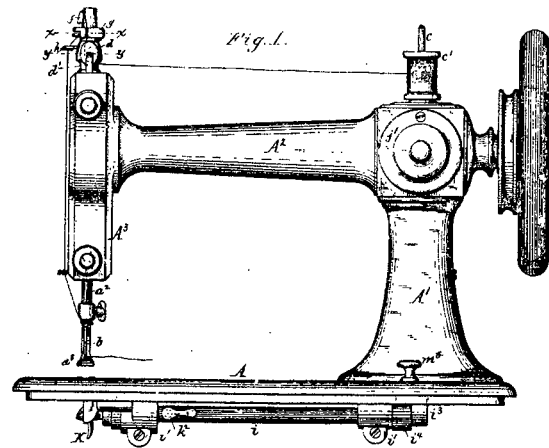
Sydney, 10 September, 1883.  
We have, &c.,

EDMUND FOSBERY.  
GOTHER K. MANN.

The Under Secretary of Justice.

---

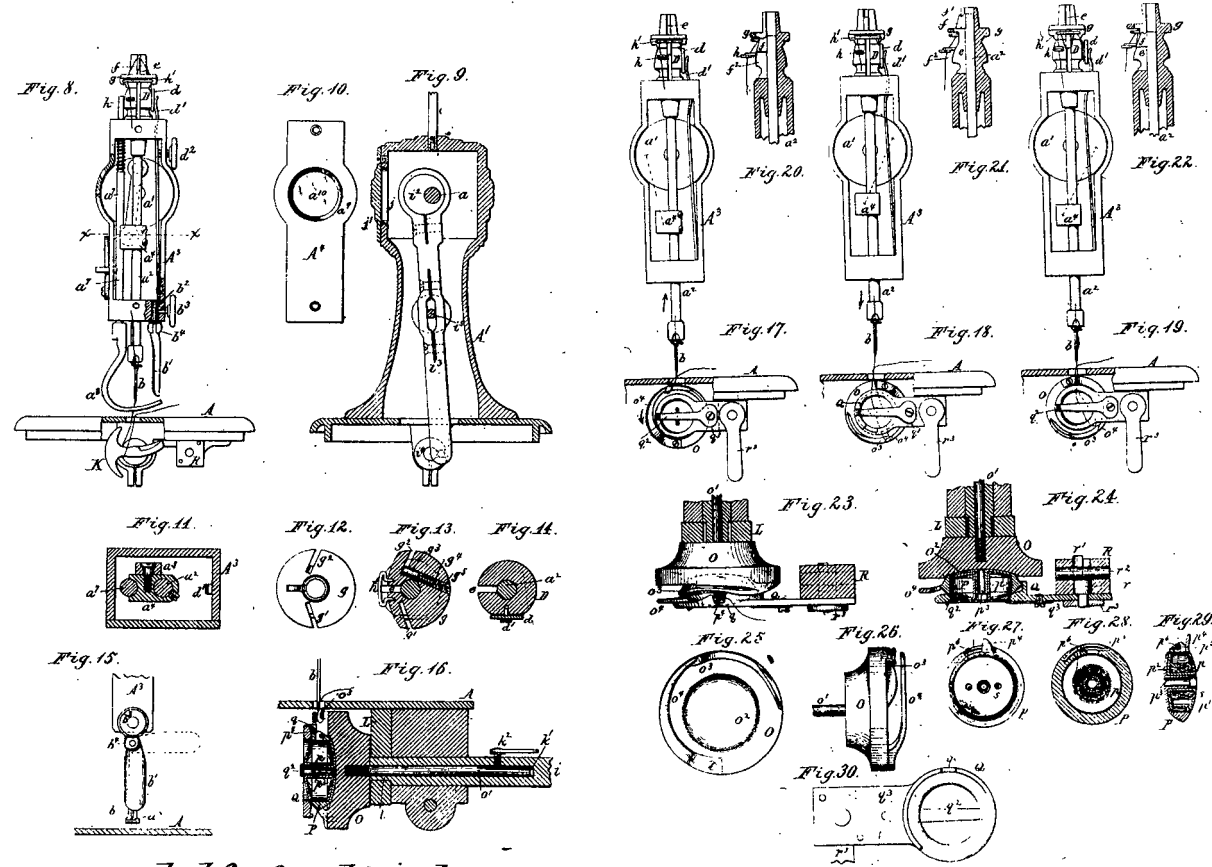
[Drawings—two sheets.]



*This is the Sheet of Drawings marked Preferred to in  
 the annexed Letters of Registration granted to John  
 William Post, this 25<sup>th</sup> day of October A.D. 1883.*

*Sig 35.*

*Augustus I. oftus.*



*This is the Sheet of Drawings marked C referred to in the annexed Letters of Registration granted to John William Post, this 25<sup>th</sup> day of October A. D. 1883.*

*Augustus Loftus*

*Fig. 35.*

PHOTO-LITHOGRAPHED AT THE GOVT. PRINTING OFFICE, SYDNEY, NEW SOUTH WALES.




---

A.D. 1883, 26th October. No. 1331.

---

IMPROVEMENTS IN DYNAMO-ELECTRIC MACHINES.

LETTERS OF REGISTRATION to Sir William Thomson, Sebastian Liani de Ferranti, and Alfred Thompson, for an Improvement in Dynamo-electric Machines.

[Registered on the 27th day of October, 1883, in pursuance of the Act 16 Vic. No. 24.]

BY HIS EXCELLENCY THE RIGHT HONORABLE SIR AUGUSTUS WILLIAM FREDERICK SPENCER LOFTUS (commonly called LORD AUGUSTUS LOFTUS), Knight Grand Cross of the Most Honorable Order of the Bath, a Member of Her Majesty's Most Honorable Privy Council, Governor and Commander-in-Chief of the Colony of New South Wales and its Dependencies.

TO ALL TO WHOM THESE PRESENTS SHALL COME, greeting:

WHEREAS SIR WILLIAM THOMSON, of Glasgow, county of Lanark, North Britain, Knight, Doctor of Laws, and Professor of Natural Philosophy, University of Glasgow, SEBASTIAN LIANI DE FERRANTI, of Richmond Gardens, Shepherd's Bush, and ALFRED THOMPSON, of Guildford Place, Russell Square, both in the county of Middlesex, in England, electricians, have by their Petition humbly represented to me that they are the authors or designers of a certain invention or improvement in manufactures, that is to say, of an invention entitled "Improvements in Dynamo-electric Machines," which is more particularly described in the specification, marked A, which is hereunto annexed, and the two sheets of drawings, marked B and C respectively, which are also hereunto annexed; and that they, the said Petitioners, have deposited with the Honorable the Treasurer of the said Colony of New South Wales the sum of Twenty Pounds sterling, for defraying the expense of granting these Letters of Registration, as required by the Act of Council, sixteenth Victoria, number twenty-four; and have humbly prayed that I would be pleased to grant Letters of Registration whereby the exclusive enjoyment and advantage of the said invention or improvement might be secured to them for a period of fourteen years: And I, being willing to give encouragement to all inventions and improvements in the arts or manufactures which may be for the public good, and having received a report favourable to the prayer of the said Petition from competent persons appointed by me to examine and consider the matters stated therein and to report thereon for my information, am pleased, with the advice of the Executive Council, and in exercise of the power and authority given to me by the said Act of Council, to grant, and do by these Letters of Registration grant unto the said Sir William Thomson, Sebastian Liani de Ferranti, and Alfred Thompson, their executors, administrators, and assigns, the exclusive enjoyment and advantage of the said invention or improvement for and during the term of fourteen years from the date hereof; to have, hold, and exercise unto the said Sir William Thomson, Sebastian Liani de Ferranti, and Alfred Thompson, their executors, administrators, and assigns, the exclusive enjoyment and advantage thereof, for and during and unto the full end and term of fourteen years from the date of these presents next and immediately ensuing, and fully to be complete and ended: Provided always, that if the said Sir William Thomson, Sebastian Liani de Ferranti, and Alfred Thompson shall not, within three days after the granting of these Letters of Registration, register the same in the proper office in the Supreme Court, at Sydney, in the said Colony of New South Wales, then these Letters of Registration, and all advantages whatsoever hereby granted, shall cease and become void.

In witness whereof, I have hereunto set my sign manual, and have caused the present Letters of Registration to be sealed with the seal of the said Colony of New South Wales, at Government House, Sydney, in New South Wales, this twenty-sixth day of October, in the year of our Lord one thousand eight hundred and eighty-three.

[L.S.]

AUGUSTUS LOFTUS.

*Improvements in Dynamo-electric Machines.*

## A.

IMPROVEMENTS in Dynamo-electric Machines, and in apparatus for generating, regulating, and measuring electric currents used for working the same, and for other purposes.

A WELL-KNOWN method for the production of alternating currents is by means of bobbins of insulated wire set around the periphery wheel, which is caused rapidly to rotate and to carry the bobbins between the poles alternately north and south of electro magnets ranged around the wheel, and on either side of it, with the poles alternately north and south. When, as each bobbin approaches the pole of any magnet, a current is set up in the coils of the bobbin, and as the bobbin leaves the pole a current is set up in the opposite direction. By suitable means these currents are led into a main or outside circuit.

Now, in place of using bobbins, it has lately been proposed by Sir William Thomson to substitute one single conductor of copper or such like metal passing with very numerous corrugations in an undulating form around the wheel, and bound down to it by a banding passing round the wheel and outside a series of pins which lie in the hollows or undulations of the zigzag conductor.

It has been proposed by Dr. John Hopkinson to use single conductors wound in a zigzag manner between iron studs or pole-pieces projecting out from the side of the revolving disc or wheel. We use no iron pole-pieces, but we employ one single conductor passing in an undulating form from around the wheel, and according to our invention we so form it that there shall be as many radial portions of the zigzag conductor as there are magnets on either side of the revolving wheel, so that if the wheel were at rest this conductor might be traced in a zigzag direction, first outwards from the centre of the wheel between two adjacent poles of the fixed or field magnets on one side of the wheel, then returning inwards towards the centre between one of these poles and the pole of a third magnet, and so on until the circuit is completed.

The field magnets are so arranged that the poles of the several field magnets on one side of the wheel are alternately north and south, and so that a north pole of a magnet of one side of the wheel faces a south pole of a magnet on the opposite side of the wheel. On revolving the wheel each radial portion of the zigzag copper conductor will, as it is carried from the pairs of opposite magnets, north south to south north, have electricity generated therein centrifugally and centripetally from the pairs of magnets south north to north south, and so produce a continuous alternating current, all the radial arms of the conductor being at all time uniformly acted upon, and the maximum effect so obtained.

Also, according to our invention, we firmly bolt or fix the zigzag conductor to the wheel in such manner that the centrifugal strain which is set up when the machine is driven, and which tends to separate the conductor from the wheel, is not supported by a circumferential binding, but is transmitted to it and is sustained by the body of the wheel.

Or in place of this single zigzag conductor we may employ a coil of insulated wire or other conductor taking a like zigzag course, but passing many times around the wheel before the end is brought out to be connected with the outside circuit. The insulated conductor may be first wound in the form of a hoop, and then bent by suitable tools into the zigzag form.

In the winding of the field magnets also we cause the conductor to take a zigzag course amongst the cores arranged in a circle, and to pass alternately on the inner and outer side of each core. The conductor thus forms a double zigzag or wicker-work, in which the cores are enclosed. This method of winding, whilst completely enveloping the cores, leaves interstices which facilitate the dissipation of heat.

Figure 1 of the drawing hereunto annexed is a side elevation of a portion of the wheel and zigzag conductor of our Dynamo-electric Machines.

Figure 2 is a transverse section, and this view indicates the position of the stationary field magnets. A is the axis and B is the wheel consisting of two rings of bronze keyed or firmly fixed upon it. The rings are adapted, as the drawing shows, to embrace projections or feet formed upon the zigzag bar conductor. The conductor C is of copper, and to prevent metallic contact between the feet and the rings B, the feet are enveloped in wrappers or vulcanised fibre or other insulating material. Bolts D D pass through lugs upon the rings and through feet of the zigzag conductor and ensure the parts being securely held. The holes by which the bolts passed are lined with insulating material to prevent metallic contact between them and the conductor C.

The position of the field magnets E in respect to the moving parts is indicated in figure 2. In the machine represented there are 64 such magnets, 32 on either side. They are shown as being wound in the ordinary manner, or they may be wound according to our improved method, hereinafter more fully described.

These field magnets may be excited by a continuous current machine of any known type. In figure 3, F represents an insulated ring of phosphur bronze, which is fixed upon the axis. A and G is a lever which is caused to bear upon the ring by the coiled spring H; the lever also is insulated from the frame of the machine; it is connected with a bounding screw which forms one of the terminals of the machine, and the other terminal is upon the frame. The block at the end of the lever which bears against the ring E is preferably of copper, has numerous holes bored into its face which are filled with plumbago compressed with heavy pressure. This way of taking off a current from the revolving part of a dynamo machine by a perforated block of copper, filled in with plumbago made to bear against a ring of phosphur bronze, is applicable not only to this machine shown in the drawing, but also to other dynamo machines.

One of the ends of the zigzag conductor is made fast to the body of the wheel in such a manner as to establish a good electrical connection so that the current may pass from it to the wheel and to the frame of the machine. The other end of the zigzag conductor is kept out of contact with the wheel, and is secured to the insulating ring.

A convenient arrangement is to employ two insulated rings, F, one on either side of the wheel, and to fork or divide the end of a zigzag conductor, and carry it down on either side of the wheel to its attachment with the insulated rings.

Figures 4 and 5 show a modification according to which the feet of the zigzag conductor are dovetailed and adapted to slide laterally into corresponding grooves in the face of the wheel. The insulation of the feet is secured, as before, by enveloping them in covers of vulcanised fibre or other insulators; rings on either side attached to the wheel by screws prevent the feet escaping from the grooves.

Figures



*Improvements in Dynamo-electric Machines.*

Figures 6 and 7 illustrate our arrangement when employing a zigzag conductor passing several times around the wheel. The conductor in this case may be a flat band of copper; it is wound round and round into a circular hoop, one convolution being separated from another by ribbons of silk. The conducting ring is then bent to the zigzag form and secured to the wheel.

In this case we make the body of the wheel of brass or other suitable metal, and between this and the zigzag conductor we place a ring of wood, and we recess the wood to receive the undulations of the conductors. The attachment of the conductor is made by means of metal lugs on either side of the zigzag, firmly bolted to the metal wheel and by metal pins pressing through these lugs and lying within the undulations, as the drawing indicates. The ends of the copper band may be led down grooves in the wooden wheel and attached the one to the axis and the other to an insulated ring therein.

Figure 8 is a side elevation of one-half of a circle of field magnets having the insulated wire or conductor wound upon them according to our invention in a double zigzag or wicker position.

Figure 9 is a plan of part of one of the magnets on a larger scale. An advantage of this method of winding is that whilst such magnet is completely enveloped in the winding interstices are nevertheless left which are favourable to the dissipation of heat generated in the coils.

By a modification of the above machine we change it from a machine for producing an alternating current into a machine for producing a continuous current.

To effect this the radical portions of the zigzag conductor do not have their inner and outer ends permanently connected together, but in place thereof we arrange a series of metallic rubbers or conductors to connect the outer ends of the radial bar, and also their inner ends, so as to make up between them a zigzag circuit.

The breaks between the several rubbers of the outer set of rubbers are made to come opposite the centre of every other radial space between the magnet and the breaks between the under rubbers to come opposite the centre of the intermediate spaces. The rubbers are kept stationary in their places, and in this way cause the electricity as the copper bars revolve to be continuously going onward in one and the same direction; thus the current would only travel in a zigzag direction, partly through the revolving metal, and partly through the stationary rubbers. In order to take the current from the machine one of the rubbers will be cut at its centre, and the ends thus presented will constitute the terminals for the external circuit.

In order to excite the field magnets of the machine the whole current may be passed round them, or, as a shunt to the main circuit, a portion of the current may be passed round them. The machine may be separately excited from another source, or permanent magnets may be used.

Figure 10 of the drawings annexed shows a side elevation of one-half of a wheel with copper bars radiating out from it, and with contact plates bearing against them, as above described; the position of the field magnets is also therein.

Figure 11 is a transverse section of the same.

Figure 12 shows a side elevation of same of the bars on a larger scale.

Figure 13 shows another elevation of one of the bars, the side shown in this figure being one of the sides at right angles to the side shown at figure 12.

Figure 14 shows on a larger scale the way in which the metallic contact pieces are carried and held up to the radial copper bars—and

Figure 15 a face view of a portion of one of the rings carrying the contact pieces.

In these figures A is a revolving axis carrying the wheel B formed in two halves bolted together, and clamping between them the inner ends of a number of radial metallic bars, C, preferably of copper. The radial bars might, however, be otherwise carried from the wheel, and if desired their outer ends might be secured to a metallic tyre, but insulated therefrom. Between the outer ends of the radial bars are placed distance pieces, D, of non-conducting material when the bars C have been ranged in a circle around the shaft, and the distance pieces have been put into place between their outer ends, the two halves of the wheel are drawn together so as to make them grasp the inner end of the bar; the bars are then all drawn inwards towards the shaft by the action of inclines on the two parts of the wheel against inclines on the inner ends of the bars. EE are the field magnets; their poles are made to be alternately north and south; as above explained, they are carried by fixed supporting rings F. One of the rings F has rods, G, standing out from it at intervals, one set of rods outside the magnets, the other set on the inner side of the magnets. HI are two rings, each having lugs projecting out from them; the lugs of the large ring, H, are free to slide to and fro along the outer set of rods G, and the lugs of the smaller ring I upon the inner set of rods, G; around the rods are spiral springs which keep the rings H and I pressed towards the bars C, which radiate out from the revolving wheel.

The face of each ring, which is towards the radial bar C, carries a number of metallic contact plates, K, which are insulated from the rings and from one another. By the action of the spiral springs they are kept against the radial bars.

The breaks between the contact plates or rubbers carried by the outer ring are as shown opposite the centre of every other space between the field magnets, whilst the breaks between the contact plates or rubbers carried by the inner ring are opposite the intermediate spaces. The radial bars, with the two sets of contact plates or rubbers, thus make a continuous zigzag metallic circuit.

If a single current only is to be taken from the machine one only of the rubbers or contact plates will be cut through at its centre, as shown at L, figure 10, and an insulated conducting wire will be led from one half of the contact plates to an insulated ring on the axle, and so to the line wire of the circuit, and, similarly, the other half of the ring will be coupled to the axle or another contact ring upon it for the return current to complete the circuit: or, if a greater number of circuits is to be taken from the machine, a greater number of the contact plates or rubbers will be cut through, and the currents will then be taken off at once half of each contact plate and returned through the half of the next succeeding contact plate which by the zigzag metallic connections above described is in electrical contact therewith.

In place of metallic contact plates or rubbers being used to complete a continuous zigzag circuit through the radial bars of the revolving wheel, other ways of completing a like continuous zigzag circuit through the bars might be employed.

---

*Improvements in Dynamo-electric Machines.*

---

In each of the above-described machines the armature might be stationary and the circles of magnets revolved. The magnets also might be situated centrally, and two sets of conductors be used, one on either side of the circle of magnets.

For measuring the quantity of an alternating current passing through an electric conductor the current is passed through the primary wire of an induction coil; the terminals of the secondary coil are connected to two electrodes immersed in water slightly acidulated. The secondary induced current is directly proportional to the primary current, and the gas generated by the decomposition of water by the two electrodes is proportional to the current passing through the secondary coil.

The amount of gas generated is to be measured in any suitable apparatus such as now used for measuring gas, but preferably we employ for this purpose a small gas-measuring chamber, which is open at the bottom, and at the top is carried by a central horizontal axis on which it can rock.

The horizontal axis is placed vertically above the electrodes, and a partition is carried downwards from it to divide the measuring chamber into two compartments. An arm also extends vertically upwards above the axis; its weight causes it to incline over to one side or the other, and so to incline the measuring chamber.

The extent to which it can be so inclined is controlled by fixed steps against which the arm strikes. When the measuring chamber is inclined in one or other position both electrodes are below the lower compartment, and the gas rising up from them collects in this compartment.

When sufficient gas is collected in the compartment to cause it to rise the chamber rocks on its axis until the compartment comes into a position in which it empties itself of gas, whilst, at the same time, the other compartment comes into position above the electrodes, this latter compartment now in turn gets filled with gas, and so the generation goes on continuously. The rocking chamber, by a pawl, is made to give a step-by-step revolving motion to a ratchet wheel on the first spindle of a recording train of wheels, and so the number of oscillations of the measuring chamber are recorded.

For regulating an electric current where the current is produced by dynamo machine, we transmit from the axis of the dynamo machine, or from the motor engine which drives it, continuous revolving motion in opposite directions to two wheels which are mounted loosely upon a spindle; between the wheels, and capable of sliding upon the spindle, we place a clutch which can be slidden endwise along the spindle, and which is drawn continuously in one direction by a spring. The spring draws the clutch against one of the wheels and locks the spindle to this wheel when no current or too weak a current is passing. When the current is of sufficient strength the clutch is drawn in the opposite direction in the following manner:—

The clutch is connected by a link to a movable coil acted upon by two stationary coils through which the electric current whose quantity it is desired to regulate is caused to pass. The coils are each of an oblong form, and the movable coil is mounted in such a way that it can pivot around a central axis parallel with its two longer sides.

The two fixed coils are side by side at a distance apart parallel with one another; the movable coil is of a smaller length than the fixed coils, and is at right angles to them, so that its two opposite sides may enter into the hollow spaces in the centre of the two fixed coils.

The spring above mentioned draws the movable coil into a position somewhat inclined to the fixed coils. As the current increases in strength the action of the coils tends more and more to turn the movable coil in the opposite direction to that in which it is drawn by the spring, and when of sufficient strength it predominates over the spring; when it does so, and the movable coil approaches a position at right angles to the fixed coils, it draws the clutch away from the wheel it was previously locking to the spindle, and the spindle will then no longer be driven. A still further increase in the strength of the current moves the clutch far enough to lock the other wheel to the spindle; the spindle will then be made to revolve in the opposite direction to that in which it was revolved previously.

The motion given to the spindle may be caused to vary the expansion by acting on the link motion, or to otherwise control the speed of the engine; or it may be made to traverse to and fro a contact bar for throwing in and out resistances; or for cutting out a portion of the wire around the field magnets of the dynamo machine.

We claim,—

First—Our improved dynamo-electric machine with no iron armature pole-pieces, but with a zigzag conductor so formed that the radial parts of the zigzag are at the same distance apart as the field magnet poles on either side of it, substantially as described.

Second—Our improved dynamo-electric machine in which the armature or revolving part consists of a wheel connected by a zigzag conductor bolted or attached to the wheel in such manner as to transmit to the body of the wheel the centrifugal strain which arises from the rotation of the zigzag conductor, and which tends to separate it from the wheel.

Third—Our improved dynamo-electric machine in which the armature or revolving part consists of a wheel encircled by a zigzag conductor formed by winding a wire or metal band with suitable insulation round and round into a hoop, and then binding the hoop to a zigzag form and attaching it to the periphery of the wheel.

Fourth—Our improved double zigzag method of winding the field magnets of dynamo electric machine.

Fifth—The construction of dynamo-electric machines or electric generators for producing continuous currents with the armature made up into a zigzag conductor, composed partly of radial conducting bars in a magnetic field and partly of contact bars or equivalent mechanism for making the required contacts between the outer ends of the bars and between the inner ends of the bars, substantially as hereinbefore described.

Sixth—The means substantially as described and shown at figure 11, of securing the radial conducting bars to the wheel. Seventh

*Improvements in Dynamo-electric Machines.*

Seventh—The employment for carrying off an electric current from the revolving axle or other part of a dynamo machine of a perforated block of copper, with the perforations filled in with compressed plumbago, to act against a ring of phosphor bronze surrounding the revolving axle.

WILLIAM THOMSON.  
SEBASTIAN DE FERRANTI.  
ALFRED THOMPSON.

(*Per* THOS. J. SOUTHERN, Clerk to Messrs. Want, Johnson, & Scarvell, Attorneys for the Applicants.)

This is the specification marked A referred to in the annexed Letters of Registration granted to Sir William Thomson, Sebastian Liani de Ferranti, and Alfred Thompson, this twenty-sixth day of October, A.D. 1883.

AUGUSTUS LOFTUS.

---

REPORT.

Sir,

We do ourselves the honor to report, in reply to your blank cover of the 28th ultimo, No. 10,857, transmitting Sir William Thomson, Sebastian Liani de Ferranti, and Alfred Thompson's Petition for the registration of an invention entitled "Improvements in apparatus for generating and regulating Electric Currents used in working Dynamo Machines, and for other purposes," that we are of opinion the prayer of the Petitioners may now be granted, in terms of their specification, drawings, and claim.

We have, &c.,

E. C. CRACKNELL.  
GOTHER K. MANN.

The Under Secretary of Justice.

---

[Drawings—two sheets.]

B.

1331.

Fig.1.

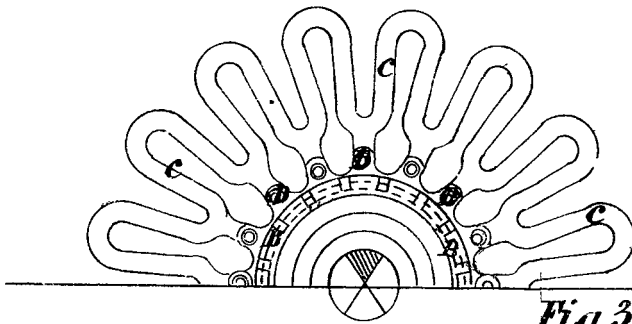


Fig.2.

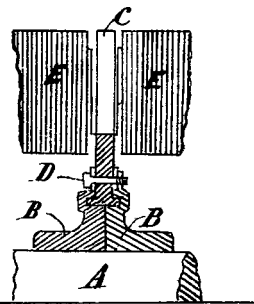


Fig 3.

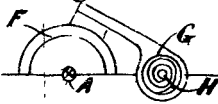


Fig.4.

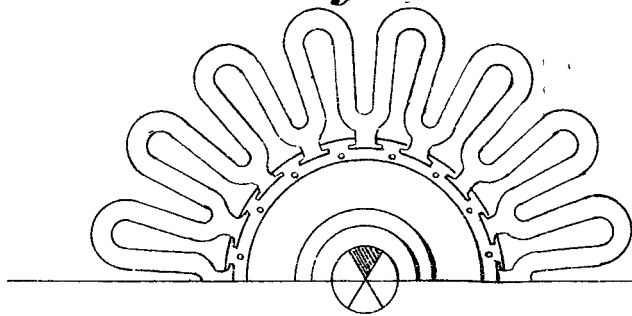


Fig.5

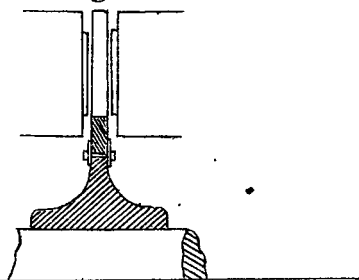


Fig. 6.

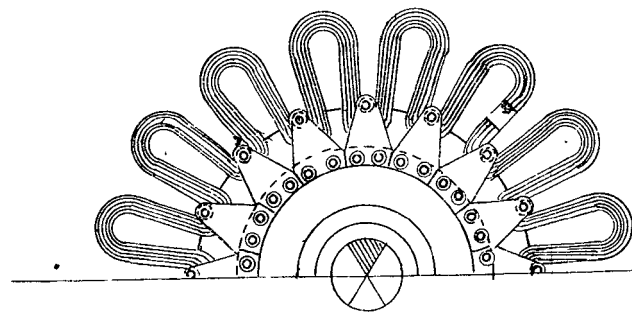
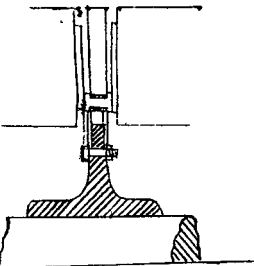


Fig.7.



*This is the Drawing referred to in the annexed Specification containing Figures 1 to 7 inclusive*

*This is the Sheet of Drawings marked "B" referred to in the annexed Letters of Registration granted to Sir William Thomson Sebastian Liani de Ferranti and Alfred Thompson, this 26<sup>th</sup> day of October, AD. 1883.*

*(Sig: 35)*

*Augustus Loftus.*

"C"

1331.

Fig 8.

Fig 9.

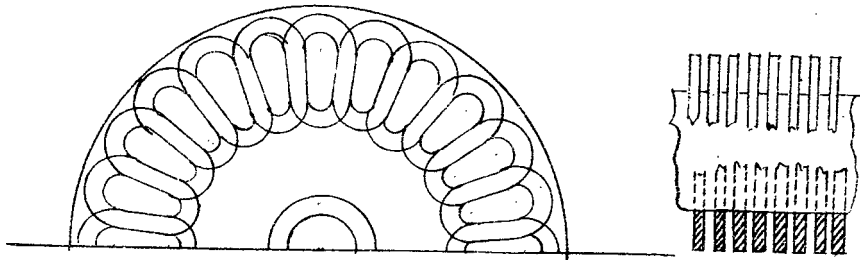


Fig 10.

Fig 11

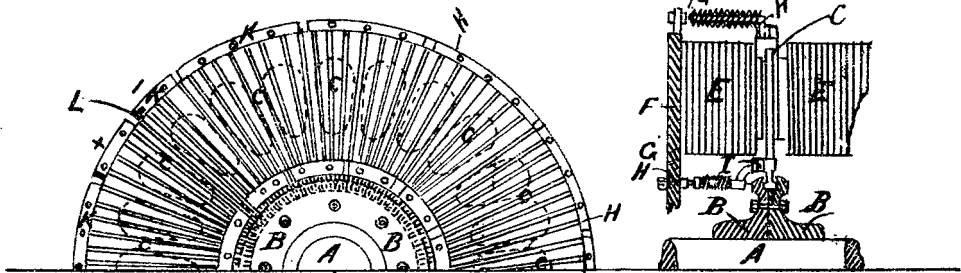
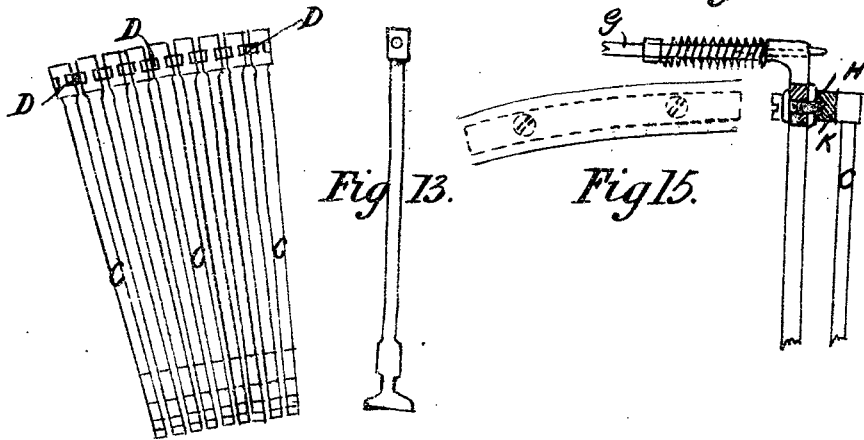


Fig. 12.

Fig. 14



*This is the Drawing referred to in the annexed Specification, containing Figures 8 to 15 inclusive*

*This is the Sheet of Drawings marked C. referred to in the annexed Letters of Registration granted to Sir William Thomson, Sebastian Liani de Ferranti, and Alfred Thompson this 26<sup>th</sup> day of October, A.D. 1883.*

*Augustus Loftus.*

(Sig 35.)



A.D. 1883, 26th October. No. 1332.

**IMPROVEMENTS IN APPARATUS FOR GENERATING AND REGULATING ELECTRIC CURRENTS USED IN WORKING DYNAMO MACHINES, &c.**

LETTERS OF REGISTRATION to Sir William Thomson, Sebastian Liani de Ferranti, and Alfred Thompson, for Improvements in apparatus for generating and regulating Electric Currents used in working Dynamo Machines, and for other purposes.

[Registered on the 27th day of October, 1883, in pursuance of the Act 16 Vic. No. 24.]

BY HIS EXCELLENCY THE RIGHT HONORABLE SIR AUGUSTUS WILLIAM FREDERICK SPENCER LOFTUS (commonly called LORD AUGUSTUS LOFTUS), Knight Grand Cross of the Most Honorable Order of the Bath, a Member of Her Majesty's Most Honorable Privy Council, Governor and Commander-in-Chief of the Colony of New South Wales and its Dependencies.

TO ALL TO WHOM THESE PRESENTS SHALL COME, greeting :

WHEREAS SIR WILLIAM THOMSON, of Glasgow, county of Lanark, North Britain, Knight, Doctor of Laws and Professor of Natural Philosophy, University of Glasgow, SEBASTIAN LIANI DE FERRANTI, of Richmond Gardens, Shepherd's Bush, and ALFRED THOMPSON, of Guildford Place, Russel Square, both in the county of Middlesex, in England, electricians, have by their Petition humbly represented to me that they are the authors or designers of a certain invention or improvement in manufactures, that is to say, of an invention entitled "Improvements in apparatus for generating and regulating Electric Currents used in working Dynamo Machines, and for other purposes," which is more particularly described in the specification, marked A, and the two sheets of drawings, marked B and C respectively, and hereunto annexed; and that they, the said Petitioners, have deposited with the Honorable the Treasurer of the said Colony of New South Wales the sum of Twenty Pounds sterling, for defraying the expense of granting these Letters of Registration, as required by the Act of Council, sixteenth Victoria, number twenty-four; and hath humbly prayed that I would be pleased to grant Letters of Registration, whereby the exclusive enjoyment and advantage of the said invention or improvement might be secured to them for a period of fourteen years: And I, being willing to give encouragement to all inventions and improvements in the arts or manufactures which may be for the public good, and having received a report favourable to the prayer of the said Petition, from competent persons appointed by me to examine and consider the matters stated therein and to report thereon for my information, am pleased, with the advice of the Executive Council, and in exercise of the power and authority given to me by the said Act of Council, to grant, and do by these Letters of Registration grant unto the said Sir William Thomson, Sebastian Liani de Ferranti, and Alfred Thompson, their executors, administrators, and assigns, the exclusive enjoyment and advantage of the said invention or improvement for and during the term of fourteen years from the date hereof; to have, hold, and exercise unto the said Sir William Thomson, Sebastian Liani de Ferranti, and Alfred Thompson, their executors, administrators, and assigns, the exclusive enjoyment and advantage thereof, for and during and until the full end and term of fourteen years from the date of these presents next and immediately ensuing, and fully to be complete and ended: Provided always, that if the said Sir William Thomson, Sebastian Liani de Ferranti, and Alfred Thompson shall not, within three days after the granting of these Letters of Registration, register the same in the proper office in the Supreme Court, at Sydney, in the said Colony of New South Wales, then these Letters of Registration, and all advantages whatsoever hereby granted, shall cease and become void.

In witness whereof, I have hereunto set my sign manual, and have caused the present Letters of Registration to be sealed with the seal of the said Colony of New South Wales, at Government House, Sydney, in New South Wales, this twenty-sixth day of October, in the year of our Lord one thousand eight hundred and eighty-three.

[L.S.]

AUGUSTUS LOFTUS.

*Improved Apparatus for working Dynamo Machines.*

A.

SPECIFICATION of "An Improved Apparatus for Generating and Regulating Electric Currents used in working Dynamo Machines, and for other purposes."

FIGURE 18 shows a vertical section, and figure 19 a horizontal section, of a regulating apparatus constructed as described.

In these figures, A B are two wheels loose on a spindle, C, and each driven in opposite directions from a wheel D, driven continuously from the dynamo machine on the motor engine; or, in place of the wheel D, other ways of driving the wheels A B in opposite directions from the dynamo machine or its motor engine might be adopted.

E is a clutch capable of sliding to and fro along the spindle, but not of turning around it. It is a lever turning on a fulcrum at F, by which the clutch can be slidden to and fro, and capable of locking either wheel to the spindle, according to which wheel it is made to engage with.

G is a spring by which the lever is drawn in one direction; the strength of the spring can be controlled by the regulating screw G'. It is a correcting rod, by which the lever F can be drawn in the opposite direction. It is coupled to a coil, I, mounted as shown, so that it can turn on its central longitudinal axis. The coupling of the rod to the coil is on one side of the central axis, so that when the coil turns on its axis the rod is moved endwise.

J J are two fixed coils at right angles to the central position of the coil I, and of larger diameter than this coil, so that the sides of the coil I may enter into the central spaces of the coils J, as shown. The current to be regulated, or a shunt circuit of a portion of this current, is passed through all three coils of the apparatus; then acts as above explained to revolve the spindle C in one or other direction, according as the current is too weak or too strong. The spindle is shown in the drawings as giving motion to a second spindle, K, which, in turn, gives a slower revolving motion to a third spindle by worm and worm-wheel gear, and the movement of this third spindle may be made to control the speed of the motor engine, or otherwise control the strength of the current, as explained.

If the action of the swinging coil is not strong enough or sensitive enough to move the clutch arrangement of the coil might be used to operate contacts, to throw in or out of action electro magnets, to draw the clutch in one or other direction.

In our electric-arc lamp we actuate the carbon-holders by means of right- and left-handed screws, which we cause to rotate at the proper times, to approach or to separate the carbons by means of a pair of electric motors. Each of these electric motors may consist of an electro magnet operating an armature connected with a pawl, which turns a ratchet wheel. So long as the motor is in action the armature oscillates as in an electric bell, and is caused to do so by like means.

When an alternating current is used the armatures are caused to vibrate by the alternation of the current, and polarised magnets may then be used.

The electro magnet of the motor which approaches the carbons has its coils shunting the arc, and the electro magnet of the motor which separates the carbons has its coils shunting a portion of the main circuit; or these coils may be in the main circuit, in which case the approach of the armature to the pole of the magnet short circuits its coils.

The contacts for this pair of motors, which bring one or other of them into action, are made by means of a rocking lever. The way in which this lever is controlled will vary according to the sort of regulation which is desired. Thus, a single lamp may be regulated by a solenoid in the main circuit operating upon an iron core attached to one arm of the lever, and resisted by a spring attached to the other arm. When the solenoid preponderates the contact is established for the motor which separates the carbons; when the spring preponderates then the contact is established for the motor which approaches the carbons. Or the solenoid, in place of being in the main circuit, may shunt the arc, and this arrangement may be employed where there is more than one lamp in circuit. But where there are several lamps in circuit a differential arrangement with two solenoids is preferable—one solenoid in the main circuit, and another shunting the arc with cores on opposite sides of the fulcrum of the lever.

For a motor having its coils in the main circuit the regulating lever shunts the motor until the time comes for the motor to operate, and then the lever opens the shunt.

By like means we can maintain a constant electro-motive force upon a circuit of incandescent lamps, the influence of a solenoid in the circuit being in this case balanced against a spring. The screws shift sliding contacts, increasing or diminishing the resistance in circuit. Other gear may be substituted for screws.

Figures 20 and 21 of the drawings hereunto annexed show two constructions of electric-arc lamps, arranged as above described.

In figure 20, A B are two electro magnets, each operating an armature carried by one arm of levers, C, the other arms of which carry pawls. D E' shows one of two ratchet wheels, which are side by side on an axis, E. One pawl can be made to act against the teeth of one wheel, the other pawl to act against the teeth of the other wheel. The pawls do not remain in contact with the teeth of the ratchet wheels. Springs F press back the levers, and keep the pawls clear of the wheels; but when either one or the other of the magnet armatures is attracted by its magnet, and so made to rock the lever which carries it, the pawl at the end of that lever acts against its ratchet wheel, and gives a partial turn to the axis E in one or other direction, according to which ratchet it is that comes into action. When the armatures are not attracted by their magnets contact points on the ends of the levers which carry the armatures rest against contact pieces—one marked G, the other H. The contact piece G is connected to another contact piece G', and H to H'. The contact pieces G' H' are in proximity to the ends of a rocking lever, I. One end of the lever carries the iron core of a solenoid; K, the other, has a coiled spring, J, attached to it. The lever is always in connection through the standard which carries it with one pole of the battery, a slight resistance, L, being interposed between this standard and the terminal X. A shunt circuit from this terminal leads through the coil of the magnet A, and the contact G to G'. When the spring preponderates over the action of the solenoid K the lever is drawn by the spring against G'; the shunt circuit is then completed through the lever, and the armature of the magnet A is made to vibrate to and fro, and the axis E is by this movement turned in a direction to separate the carbons, and

continues

*Improved Apparatus for working Dynamo Machines.*

continues to do so as long as the lever I remains in contact with G<sup>1</sup>. A shunt circuit is, as shown, always passing through the coil of the solenoid to the terminal Y. As the carbons arc separated, and the resistance of the arc gets greater and greater, more and more of the current traverses the shunt circuit through the solenoid, until the iron core is attracted sufficiently to overcome the action of the spring J, and lift the lever from the contact G<sup>1</sup>. A further increase of resistance in the arc will cause the iron core of the solenoid to bring the lever I into contact with H<sup>1</sup>. A shunt circuit will then, as shown, be completed through H, and through the coil of the electro magnet B; the armature of this magnet will therefore be vibrated to and fro, and the axis E will be turned in a direction to approach the carbons.

In the drawing, the axis E is represented as having upon it two pinions gearing upon opposite sides with two racks—one in connection with the holder of one carbon, the other with the holder of the other carbon; but other mechanism might be used for conveying motion from the axis E to the carbon-holders.

Figure 21 shows a diagram view of a regulator for an electric-arc lamp, in which the regulation is effected by a differential arrangement with two solenoids. In the figure the same letter indicates like parts to those shown at figure 20.

The main current passes from terminal X through the solenoid J to the standard carrying the axis of rocking lever I, and a shunt circuit of greater resistance through the coil of the solenoid K to the other terminal, Y. When the action of the solenoid K preponderates over the action of the solenoid J the lever is brought against the contact piece H<sup>1</sup>, and a shunt circuit is opened through the coils of the electro magnet B, as in arrangement shown in figure 20, and the axis E is consequently turned in a direction to cause the carbons to approach one another. During this time the current has passed to the lower carbons through a spring, I<sup>1</sup>, carried by the lever I to the contact piece G<sup>1</sup>, and through G direct to the carbon-holders, as shown. When, however, the solenoid J preponderates over the solenoid K the spring I<sup>1</sup> is carried away from the contact piece G<sup>1</sup>, and the current then passes through the coils of the magnet A. The armature of this magnet being then attracted, draws a contact point on the lower end of the lever which carries it against the contact G, and so again opens a direct passage for the current to the lower carbon, and the magnet being no longer sufficiently excited to attract its armature the armature is withdrawn from it, and is so kept vibrating to and fro, and the axis E is revolved in a direction to separate the carbons.

In place of electro magnets, a vibrating coil made to vibrate by a fixed coil or coils, or a rotating coil acted upon by a stationary coil or other appliance for obtaining movement by electricity, might be employed, instead of using a fixed electro magnet and vibrating armature, for giving motion to the carbons, as above described.

Other forms of solenoid than the one shown might also be used for putting into action the electric-motor apparatus used for giving motion to the carbons.

The mechanism above described might also be used for controlling the strength of electric currents, the electric-motor apparatus being for this purpose caused to give a to-and-fro motion to a bar to shut out or bring in resistances, or cause to act, as hereinbefore more fully described, upon the expansion gear or cut off valve apparatus of a steam-engine used for driving the dynamo machine employed for generating the electric current.

We claim—

The combination of mechanism for regulating currents of electricity, substantially as hereinbefore described with reference to figures 18 and 19 of the drawings annexed.

The combination of a solenoid operated by a shunt circuit from the main circuit acting against a spring for controlling contact apparatus for setting into action either one or other of two electro motors for moving the carbons of an electric-arc lamp, either towards or away from one another, or for regulating the strength of an electric current, substantially as hereinbefore described with reference to figure 20.

The combination of two solenoids operated by the main circuit, the other by a shunt circuit of greater resistance, acting in opposition to one another, for controlling the action of contact apparatus for moving the carbons of an electric-arc lamp either towards or away from one another, or for regulating the strength of an electric current, substantially as described with reference to figure 21.

This is the specification marked A referred to in the annexed Letters of Registration granted to Sir William Thomson, Sebastian Liani de Ferranti, and Alfred Thompson, this twenty-sixth day of October, A.D. 1883.

AUGUSTUS LOFTUS.

### REPORT.

Sir,

We do ourselves the honor to reply to your blank cover of the 28th August, No. 10,858, transmitting Sir William Thomson, Sebastian Liani de Ferranti, and Alfred Thompson's Petition for the registration of an invention entitled "Improvements in apparatus for measuring Electric Currents used in working Dynamo Machines, and for other purposes," that we are of opinion the prayer of the Petitioners may now be granted, in terms of their specification, drawing, and claim.

We have, &c.,  
E. C. CRACKNELL.  
GOTHER K. MANN.

The Under Secretary of Justice.

[Drawings—two sheets.]



"B"

1332.

Fig. 18

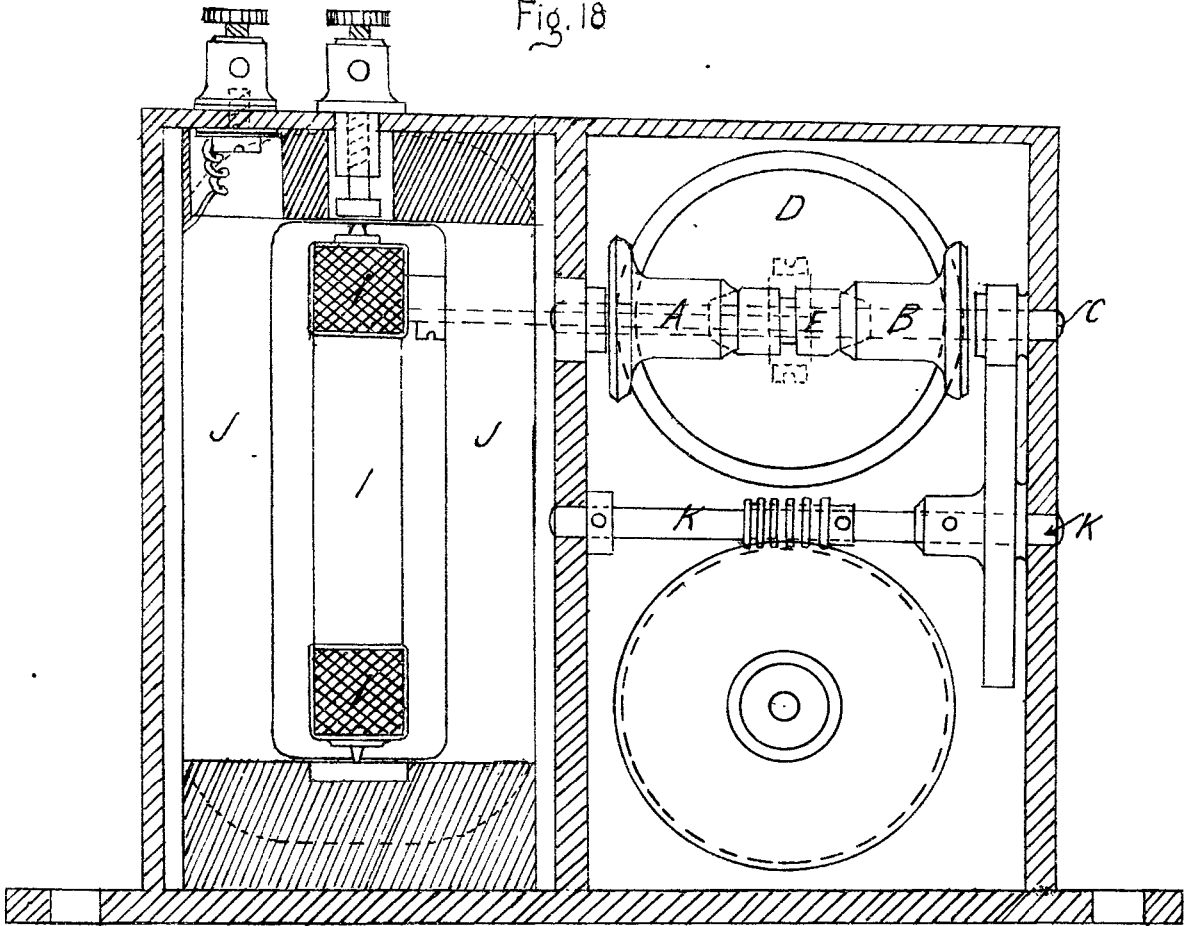
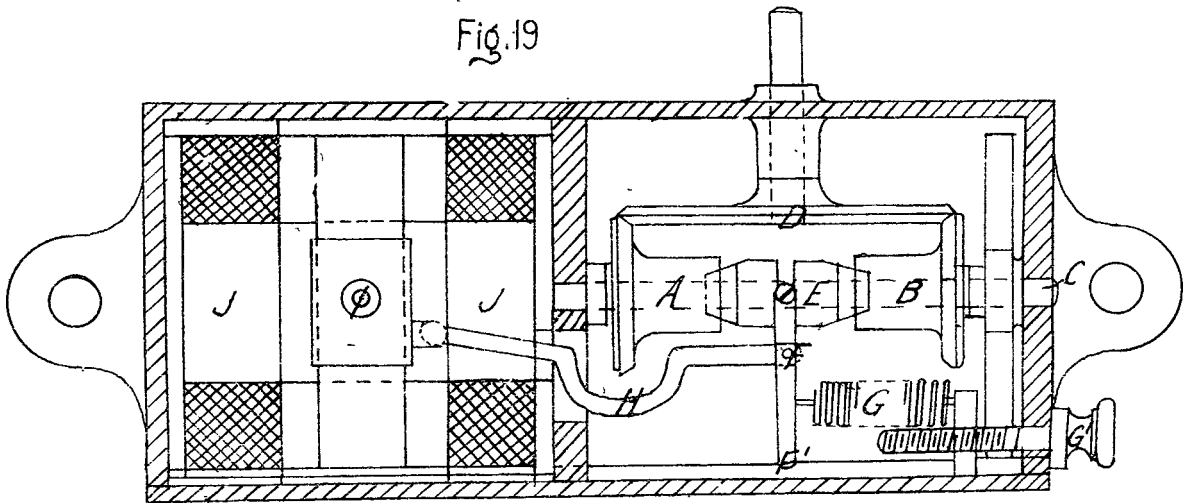


Fig. 19



*This is the Drawing referred to in the annexed Specification containing Figures 18 & 19.*

*This is the Sheet of Drawings marked "B" referred to in the annexed Letters of Registration granted to Sir William Thomson, Sebastian Liani de Ferranti, and Alfred Thompson, this twenty sixth day of October, A.D. 1883.*

*Augustus Loftus.*

*(Sig 35-)*

"C"

1332.

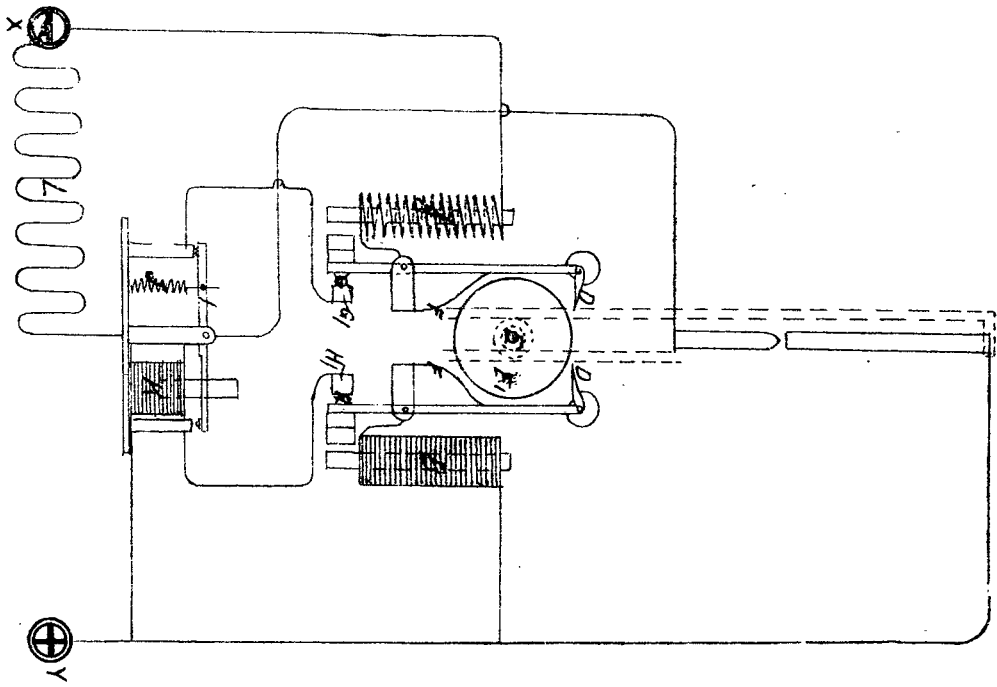


Fig. 20.

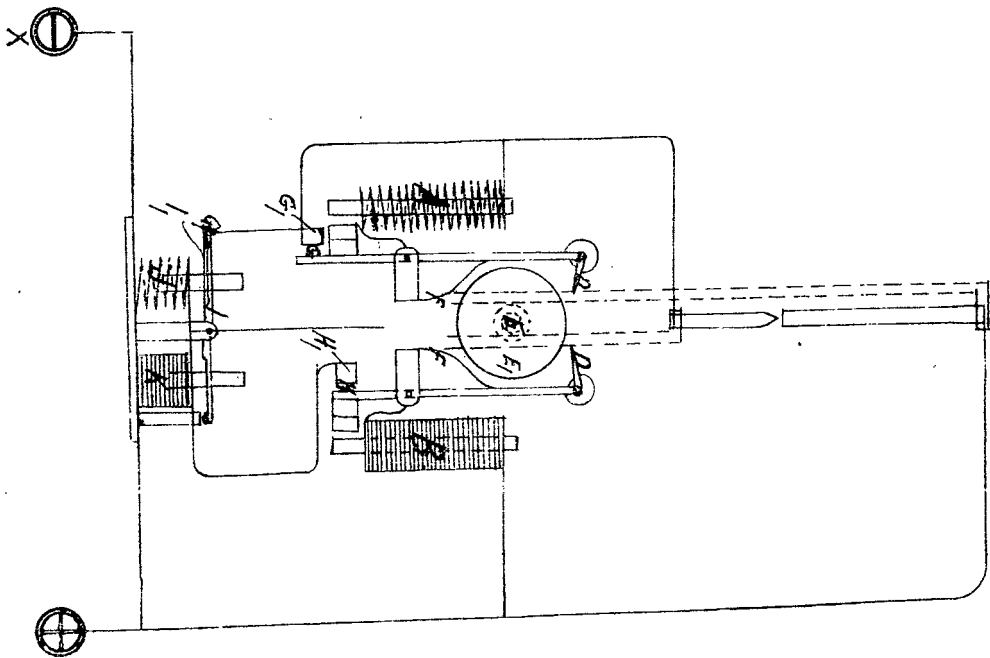


Fig. 21.

*This is the Drawing referred to in the annexed Specification containing Figures 20 & 21.*

*This is the Sheet of Drawings marked "C" referred to in the annexed Letters of Registration granted to Sir William Thomson, Sebastian Liara de Ferranti, and Alfred Thompson, this twenty sixth day of October, A. D. 1883.*

*Augustus Loftus.*

*(Sig 35-)*



A.D. 1883, 26th October. No. 1333.

**IMPROVEMENTS IN APPARATUS FOR MEASURING ELECTRIC CURRENTS USED  
IN WORKING DYNAMO MACHINES AND FOR OTHER PURPOSES.**

**LETTERS OF REGISTRATION** to Sir William Thomson, Sebastian Liani de Ferranti, and Alfred Thompson, for Improvements in Apparatus for Measuring Electric Currents used in working Dynamo Machines and for other purposes.

[Registered on the 27th day of October, 1883, in pursuance of the Act 16 Vic. No. 24.]

BY HIS EXCELLENCY THE RIGHT HONORABLE SIR AUGUSTUS WILLIAM FREDERICK SPENCER LOFTUS (commonly called LORD AUGUSTUS LOFTUS), Knight Grand Cross of the Most Honorable Order of the Bath, a Member of Her Majesty's Most Honorable Privy Council, Governor and Commander-in-Chief of the Colony of New South Wales and its Dependencies.

TO ALL TO WHOM THESE PRESENTS SHALL COME, greeting :

WHEREAS SIR WILLIAM THOMSON, of Glasgow, county of Lanark, North Britain, Knight, Doctor of Laws, and Professor of Natural Philosophy, University of Glasgow, SEBASTIAN LIANI DE FERRANTI, of Richmond Gardens, Shepherd's Bush, and ALFRED THOMPSON, of Guildford Place, Russell Square, both in the county of Middlesex, in England, electricians, have by their Petition humbly represented to me that they are the authors or designers of a certain invention or improvement in manufactures, that is to say, of an invention entitled "Improvements in Apparatus for Measuring Electric Currents used in working Dynamo Machines and for other purposes," which is more particularly described in the specification, marked A, and the sheet of drawings, marked B, hereunto annexed; and that they, the said Petitioners, have deposited with the Honorable the Treasurer of the said Colony of New South Wales the sum of Twenty Pounds sterling, for defraying the expense of granting these Letters of Registration, as required by the Act of Council, sixteenth Victoria, number twenty-four; and have humbly prayed that I would be pleased to grant Letters of Registration, whereby the exclusive enjoyment and advantage of the said invention or improvement might be secured to them for a period of fourteen years: And I, being willing to give encouragement to all inventions and improvements in the arts or manufactures which may be for the public good, and having received a report favourable to the prayer of the said Petition, from competent persons appointed by me to examine and consider the matters stated therein and to report thereon for my information, am pleased, with the advice of the Executive Council, and in exercise of the power and authority given to me by the said Act of Council, to grant, and do by these Letters of Registration grant unto the said Sir William Thomson, Sebastian Liani de Ferranti, and Alfred Thompson, their executors, administrators, and assigns, the exclusive enjoyment and advantage of the said invention or improvement, for and during the term of fourteen years from the date hereof; to have, hold, and exercise unto the said Sir William Thomson, Sebastian Liani de Ferranti, and Alfred Thompson, their executors, administrators, and assigns, the exclusive enjoyment and advantage thereof, for and during and unto the full end and term of fourteen years from the date of these presents next and immediately ensuing, and fully to be complete and ended: Provided always, that if the said Sir William Thomson, Sebastian Liani de Ferranti, and Alfred Thompson shall not, within three days after the granting of these Letters of Registration, register the same in the proper office in the Supreme Court, at Sydney, in the said Colony of New South Wales, then these Letters of Registration, and all advantages whatsoever hereby granted, shall cease and become void.

In witness whereof, I have hereunto set my sign manual, and have caused the present Letters of Registration to be sealed with the seal of the said Colony of New South Wales, at Government House, Sydney, in New South Wales, this twenty-sixth day of October, in the year of our Lord one thousand eight hundred and eighty-three.

[L.S.]

AUGUSTUS LOFTUS.

*An Improved Apparatus for Measuring Electric Currents.*

A.

SPECIFICATION of an Invention of an "Improved Apparatus for Measuring Electric Currents used in working Dynamo Machines and for other purposes."

FIGURE 16 shows a vertical section of measuring apparatus constructed as above described.

A B are two terminals of the primary coil of an induction coil. The primary coil is formed of a square bar, C, of copper, wound spirally around a core, D, of wood or other non-conducting material, interposed between the coils of the bar. C F is the secondary coil of insulated wire, wound around the primary coil. Its two ends are connected to two platinum plates or other electrodes standing up from the bottom of a small tank, G, containing water slightly acidulated. Above these electrodes is the vessel, H, for measuring the amount of gas rising up from the electrodes. It is, as shown by the dotted line, H', divided into two compartments. The vessel H is carried by the axis I. Standing up from the axis I is an arm, J, the upper end of which can play to and fro to a certain extent in a slot in the top or cover of the tank. It carries a pawl, K, which, as the arm vibrates to and fro along the slot, gives a step-by-step motion to a ratchet wheel, L, on the first spindle of a train of revolving wheels, such as shown at figure 17; and as each compartment is in turn filled and emptied of gas, the number of times they are filled and emptied is recorded by the train of wheels, and so records the quantity of current passed through the primary coil of the induction coil.

We claim:—

The combination of mechanism for measuring alternating currents of electricity, substantially as hereinbefore described, with reference to figures 16 and 17 of the drawings annexed.

WILLIAM THOMSON.

SEBASTIAN LIANI DE FERRANTI.

ALFRED THOMPSON.

(By their Attorney, JAMES W. JOHNSON).

This is the specification marked A referred to in the annexed Letters of Registration granted to Sir William Thomson, Sebastian Liani de Ferranti, and Alfred Thompson, this twenty-sixth day of October, A.D. 1883.

AUGUSTUS LOFTUS.

## REPORTS.

Sir,

Sydney, 15 March, 1883.

We do ourselves the honor to report, in reply to your blank cover of the 21st ultimo, No. 2,689, transmitting Messrs. Sebastian Liani de Ferranti, Alfred Thompson, and William Thomson's Petition for the registration of an invention having for its object "Improvements in Electric Arc Lamps, and in Apparatus for generating, regulating, and measuring Electric Currents used for working the same, and other purposes," that we are of opinion so much of the prayer of the Petitioners as relates to the Dynamo-Electric Machine, and as set forth in the specification in claims 1 to 7 inclusive, may be granted, but that it is necessary claim No. 9 and the remaining claims, 8, 10, and 11 should form two distinct registrations, and that separate specifications and petitions are requisite before these particular claims can be definitely reported upon.

We have, &c.,

E. C. CRACKNELL.

GOTHER K. MANN.

The Under Secretary of Justice.

Sir,

Sydney, 6 September, 1883.

We do ourselves the honor to report, in reply to your blank cover of the 28th ultimo, No. 10,856, which has reference to Sir William Thomson, Sebastian Liani de Ferranti, and Alfred Thompson's Petition for the registration of "Improvements in Dynamo-Electric Machines," that we are of opinion the prayer of the Petitioners may now be granted, in terms of the specification and claim as now corrected, in accordance with our report of the 15th March last.

We have, &c.,

E. C. CRACKNELL.

GOTHER K. MANN.

The Under Secretary of Justice.

[Drawings—one sheet.]

## No. 1334.

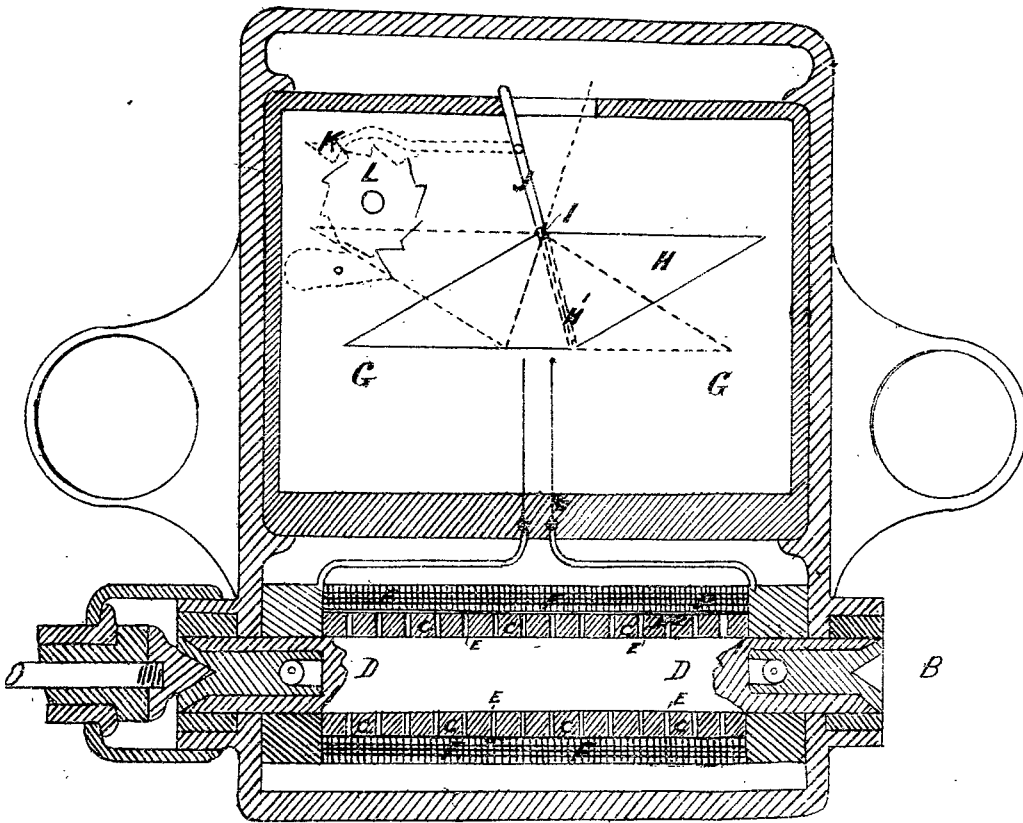
[Assignment of No. 1104. See Letters of Registration for 1882, page 277.]

## No. 1335.

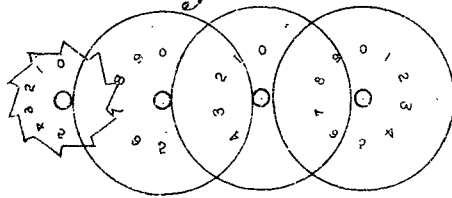
[Assignment of No. 1166. See Letters of Registration for 1882, page 449.]

*B*

*Fig. 16.*



*Fig. 17.*



*This is the Drawing referred to in the annexed Specification containing Figures 16. and 17.*

*This is the Plan or Drawing marked "B" referred to in the annexed Letters of Registration granted to William Thomson, Sebastian Iiani, de Ferranti and Alfred Thompson this 26<sup>th</sup> day of October AD. 1883.*

*(Sig. 35)*

*Augustus Loftus.*



A.D. 1883, 17th November. No. 1336.

IMPROVEMENTS IN GRAIN-STRIPPING AND WINNOWING MACHINES.

LETTERS OF REGISTRATION to William Bowman, for Improvements in Grain-stripping and Winnowing Machines.

[Registered on the 19th day of November, 1883, in pursuance of the Act 16 Vic. No. 24.]

BY HIS EXCELLENCY THE RIGHT HONORABLE SIR AUGUSTUS WILLIAM FREDERICK SPENCER LOFTUS (commonly called LORD AUGUSTUS LOFTUS), Knight Grand Cross of the Most Honorable Order of the Bath, a Member of Her Majesty's Most Honorable Privy Council, Governor and Commander-in-Chief of the Colony of New South Wales and its Dependencies.

TO ALL TO WHOM THESE PRESENTS SHALL COME, greeting :

WHEREAS WILLIAM BOWMAN, of Middleton, in the province of South Australia, miller, hath by his Petition humbly represented to me that he is the author or designer of a certain invention or improvement in manufactures, that is to say, of an invention entitled "Improvements in Grain-stripping and Winnowing Machines," which is more particularly described in the specification and the sheet of drawings which are hereunto annexed; and that he, the said Petitioner, hath deposited with the Honorable the Treasurer of the said Colony of New South Wales the sum of Twenty Pounds sterling, for defraying the expense of granting these Letters of Registration, as required by the Act of Council, sixteenth Victoria, number twenty-four; and hath humbly prayed that I would be pleased to grant Letters of Registration, whereby the exclusive enjoyment and advantage of the said invention or improvement might be secured to him for a period of fourteen years: And I, being willing to give encouragement to all inventions and improvements in the arts or manufactures which may be for the public good, and having received a report favourable to the prayer of the said Petition, from competent persons appointed by me to examine and consider the matters stated therein and to report thereon for my information, am pleased, with the advice of the Executive Council, and in exercise of the power and authority given to me by the said Act of Council, to grant, and do by these Letters of Registration grant unto the said William Bowman, his executors, administrators, and assigns, the exclusive enjoyment and advantage of the said invention or improvement, for and during the term of fourteen years from the date hereof; to have, hold, and exercise unto the said William Bowman, his executors, administrators, and assigns, the exclusive enjoyment and advantage thereof, for and during and unto the full end and term of fourteen years from the date of these presents next and immediately ensuing, and fully to be complete and ended: Provided always, that if the said William Bowman shall not, within three days after the granting of these Letters of Registration, register the same in the proper office in the Supreme Court, at Sydney, in the said Colony of New South Wales, then these Letters of Registration, and all advantages whatsoever hereby granted, shall cease and become void.

In witness whereof, I have hereunto set my sign manual, and have caused the present Letters of Registration to be sealed with the seal of the said Colony of New South Wales, at Government House, Sydney, in New South Wales, this seventeenth day of November, in the year of our Lord one thousand eight hundred and eighty-three.

[L.S.]

AUGUSTUS LOFTUS.

---

*Improvements in Grain-stripping and Winnowing Machines.*

---

SPECIFICATION of WILLIAM BOWMAN, of Middleton, in the province of South Australia, miller, for an invention entitled "Improvements in Grain-stripping and Winnowing Machines."

My invention has been designed in order that the stripping of the grain from standing crops and the winnowing of such grain may be efficiently and effectually performed in the field by the one machine.

My improvements consist, first, in the combination and arrangement of a combined separator and beater or fan, reaching from side to side, at the top of the inclined apron or slide from the stripping concave or "drum," as it is commonly called, and which separator and beater or fan revolve within a concave in a contrary direction to that of the beater in the drum, so as to winnow and separate in a great measure the chaff from the grain. They consist, secondly, in interposing a perforated concave in which revolves a perforated cylinder (both reaching from side to side) between the stripping concave or drum and the winnower, and preferably immediately behind and below my first-mentioned improvement, for the purpose of rethreshing any heads of the crop which may have inadvertently passed up the apron from the drum. They further consist in the combination and arrangement of a revolving screen reaching from side to side at the top of the air-passage from the winnower or fan, through which screen the grain must pass on the journey to its receptacle, and which throws or carries the chaff clear of the machine.

But in order that my invention may be clearly understood, I will now describe the same with reference to the drawings, in which figure 1 shows a diagrammatic view of a stripping and winnowing machine with my improvements attached. Figure 2 is a perspective view of my improved separator and beater or fan; and figure 3 is a similar view of the perforated cylinder within the perforated concave. A is the beater within the drum, and B the apron therefrom, as is well understood. C is my improved separator and beater, D is my perforated cylinder, and K the concave; G is the revolving screen, E the fan or winnower; F and H are slides, and J the grain receptacle.

My improved separator and beater C is constructed preferably in the manner shown by riveting wire netting (say seven to the inch) to a light frame, so that wire fans are formed radiating from a wire drum or cylinder of small diameter. My perforated cylinder D is formed preferably of smut-wire or punched iron, and its concave of like material. The revolving screen G is covered with wire netting, say five or six to the inch. Motion is given to these devices by belts and pulleys, the spindle of cylinder D receiving its motion from the nave of the off-bearing wheel, and imparting motion by means of belts to both the separator C and screen G, that of the former being reverse to that of the drum-beaters A, and that of the latter rather slower than that of the cylinder D.

The mode of operation of these improvements is as follows:—The grain is thrown from the beaters A up the inclined apron B, and is directed into the combined separator and beater or fan C, the wind from the beater separating in a great measure the grain from the chaff. The grain thus partly cleaned falls thence into the perforated concave K, where the perforated cylinder D threshes any heads or portions of heads that may have passed through the separator. After leaving the concave K the grain and chaff travel over slide F to the revolving screen G, where, while the grain drops through into the hopper below, the wind from the fan E and the motion of said screen G carries the chaff backward either clear of the machine or throws it upon slide H, from off which it falls to the ground.

Having thus particularly described and ascertained the nature of my said invention, and the manner in which the same is to be performed, I would have it understood that I do not claim to be the inventor of machines which strip and winnow grain in the field, but what I believe to be new, and therefore claim as my improvements in grain-stripping and winnowing machines, is—

First—The combination and arrangement of a revolving separator and beater or fan, reaching from side to side at the top of the inclined apron from the drum, substantially as herein described and explained.

Second—Interposing a perforated concave in which revolves a perforated cylinder between the drum and the winnower, substantially as herein described and explained.

Third—The combination and arrangement of a revolving screen at the top of the air-passage from the winnower, substantially as herein described and explained.

Fourth—The particular combination and arrangement of parts forming my improved grain-stripping and winnowing machine, substantially as herein described and explained, and as illustrated in the drawings.

In witness whereof, I, the said William Bowman, have hereto set my hand and seal.

WILLIAM BOWMAN,  
(By his Agent, FRED. WALSH).

This is the specification referred to in the annexed Letters of Registration granted to William Bowman, this 17th day of November, A.D. 1883.

AUGUSTUS LOFTUS.

---

*Improvements in Grain-stripping and Winnowing Machines.*

---

**REPORTS.**

---

Sir,

Sydney, 16 June, 1883.

In reply to your B.C. minute of the 23rd May, forwarding the application of William Bowman for Letters of Registration for an invention entitled "Improvements in Grain-stripping and Winnowing Machines," we are of opinion that such letters should not be issued, as the description is too vague and indefinite, and as far as we can see the invention does not possess sufficient novelty to warrant the issue of such letters.

We have, &amp;c.,

JAMES BARNET.

WILLIAM C. BENNETT.

The Under Secretary of Justice.

Sir,

Sydney, 28 July, 1883.

In accordance with your B.C. minute of 25th instant, forwarding further letter from Mr. Walsh *re* William Bowman's application for Letters of Registration for an invention styled "Improvements in Grain-stripping and Winnowing Machines," accompanied by amended specification, we are of opinion that such letters should not be granted, as protection for similar improvements has been granted to others.

We have, &amp;c.,

JAMES BARNET.

WILLIAM C. BENNETT.

The Under Secretary of Justice.

Sir,

Sydney, 31 August, 1883.

With reference to the further letter from Mr. Walsh, dated 11th August, pressing his application for the issue of Letters of Registration to William Bowman for an invention styled "Improvements in Grain-stripping and Winnowing Machines," we have to report that we have again examined the inventions referred to as already patented, and find that there is some difference in detail and arrangement, and therefore withdraw our objection to the issue of such letters in favour of Mr. Bowman's invention.

We have, &amp;c.,

JAMES BARNET.

WILLIAM C. BENNETT.

The Under Secretary of Justice.

---

[Drawings—one sheet.]



Figure 2.

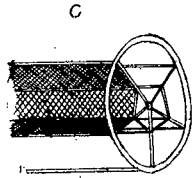


Figure 1.

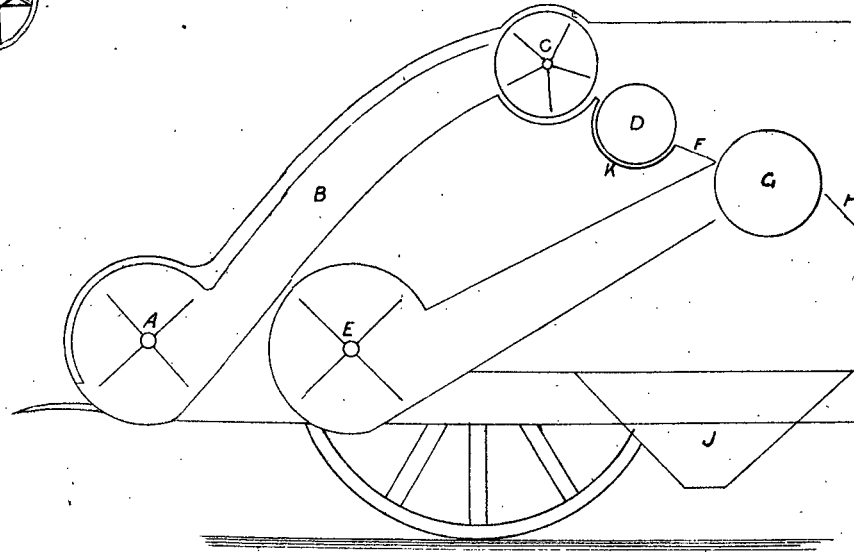
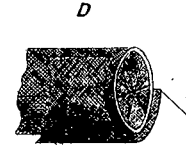


Figure 3.



*Witness*  
*W. Bowman*

*Augustus Loftus*

*This is the Sheet of Drawings referred to in the annexed  
Letters of Registration granted to William Bowman, this  
17<sup>th</sup> day of November A. D. 1883.  
Augustus Loftus.*



A.D. 1883, 17th November. No. 1337.

IMPROVEMENTS IN WINDMILLS.

LETTERS OF REGISTRATION to Josiah Earl, for Improvements in Windmills.

[Registered on the 19th day of November, 1883, in pursuance of the Act 16 Vic. No. 24.]

BY HIS EXCELLENCY THE RIGHT HONORABLE SIR AUGUSTUS WILLIAM FREDERICK SPENCER LOFTUS (commonly called LORD AUGUSTUS LOFTUS), Knight Grand Cross of the Most Honorable Order of the Bath, a Member of Her Majesty's Most Honorable Privy Council, Governor and Commander-in-Chief of the Colony of New South Wales and its Dependencies.

TO ALL TO WHOM THESE PRESENTS SHALL COME, greeting:

WHEREAS JOSIAH EARL, of San Francisco, California, one of the United States of America, at present residing at Sydney, in the Colony of New South Wales, has by his Petition humbly represented to me that he is the author or designer of a certain invention or improvement in manufactures, that is to say, of an invention entitled "Improvements in Windmills," which is more particularly described in the specification and sheet of drawings which are hereunto annexed, and marked A and B respectively; and that he, the said Petitioner, has deposited with the Honorable the Treasurer of the said Colony of New South Wales the sum of Twenty Pounds sterling, for defraying the expense of granting these Letters of Registration, as required by the Act of Council, sixteenth Victoria, number twenty-four; and has humbly prayed that I would be pleased to grant Letters of Registration, whereby the exclusive enjoyment and advantage of the said invention or improvement might be secured to him for a period of fourteen years: And I, being willing to give encouragement to all inventions and improvements in the arts or manufactures which may be for the public good, and having received a report favourable to the prayer of the said Petition, from competent persons appointed by me to examine and consider the matters stated therein and to report thereon for my information, am pleased, with the advice of the Executive Council, and in exercise of the power and authority given to me by the said Act of Council, to grant, and do by these Letters of Registration grant unto the said Josiah Earl, his executors, administrators, and assigns, the exclusive enjoyment and advantage of the said invention or improvement for and during the term of fourteen years from the date hereof; to have, hold, and exercise unto the said Josiah Earl, his executors, administrators, and assigns, the exclusive enjoyment and advantage thereof for and during and unto the full end and term of fourteen years from the date of these presents next and immediately ensuing, and fully to be complete and ended: Provided always, that if the said Josiah Earl shall not, within three days after the granting of these Letters of Registration, register the same in the proper office in the Supreme Court, at Sydney, in the said Colony of New South Wales, then these Letters of Registration, and all advantages whatsoever hereby granted, shall cease and become void.

In witness whereof, I have hereunto set my sign manual, and have caused the present Letters of Registration to be sealed with the seal of the said Colony of New South Wales, at Government House, Sydney, in New South Wales, this seventeenth day of November, in the year of our Lord one thousand eight hundred and eighty-three.

[L.S.]

AUGUSTUS LOFTUS.

*Improvements in Windmills.*

A.

SPECIFICATION of JOSIAH EARL, of San Francisco, California, one of the United States of America, at present residing at Sydney, in the Colony of New South Wales, for an invention entitled "Improvements in Windmills."

My invention relates to that class of windmills in which the wind-wheel is made up of sails proceeding radially from the hub, and which have a hinged vane to force said wind-wheel into the wind, and to fold up when the wind gets too boisterous. It consists in certain improvements by which such windmills may be more economically and conveniently constructed, and by which the adjustable parts adjust themselves more readily and certainly when so required. These improvements relate to the wind-wheel, to the supports of such wheel, and to the hinged regulating vane.

First—As to the wind-wheel: This is made up of a series of radiating wind-sails which widen as they radiate—that is to say, they are wider at their outer ends than at their inner ends. These wind-sails are each bolted in two places to a radial arm, and each such arm is bolted to a disc or flange, which, together with a second disc or flange placed on the opposite side of the radial arms and bolted to the first disc, forms the hub of the wind-wheel. These arms reach about two-thirds of the length of the sail, which is bolted to it anglewise. One of these bolts is the inner end of the sail, and the other at the outer end of the radial arm. Each bolt passes quite through the radial arm and the sail, and also through two connecting bars or arms. One of these arms connects the sail with the next one in front of it, and the other with the next one behind it. The discs which form the hub of my wind-wheel are keyed on to the wind-wheel spindle at or near its end, said spindle being cranked at the point where the pump or other rod is intended to be connected with it.

Second—As to the supports of my wind-wheel: Its spindle is supported in bearings between and formed by the upper and lower halves of a box or framing, both of which halves are bolted to the upper flanges of a central vertical tapering hollow or ribbed casting, which rests on the top of two wooden standards, between which it descends, terminating in a foot resting in a foot-step securely fastened to such standards.

Third—As to the hinged regulating vane: This is hinged at two points—first, from a bracket projecting from the vertical hollow casting just referred to; and second, from a strap or stay projecting from the upper part of the box or framing, also just referred to; but its special feature lies in the use of a spring which tends to throw the vane back to its outward position after it has been folded towards the wind-wheel by the force of the wind.

But in order that my invention may be clearly understood, I will now describe the same with reference to the drawing, in which figure 1 shows an elevation of a windmill constructed with my improvements attached, figure 2 a plan of the same, and figure 3 a back elevation partly in section. Figure 4 is a partial plan showing the vane in its most extended relative position when the mill is ready for action. Figure 5 shows detail views of a sail and its arm, figure 6 details of the inner disc or flange of the wind-wheel, and figure 7 details of the outer disc or flange. Figure 8 is a sectional view of both flanges fixed together, showing also an arm and its sail in section.

A A are the sails of the wind-wheel B the radial arms, C and C<sup>1</sup> the discs or flanges, and D the crank-shaft; A<sup>1</sup> are connecting stays. Bolts A<sup>2</sup> secure stays A<sup>1</sup>, arms B, and sails A together, while bolts A<sup>2</sup> secure inner end of sails to the arms B, bolts C<sup>2</sup> fasten arms B to flange C, and bolts C<sup>3</sup> unite the discs or flanges so as to form the hub of the wheel; said hub is keyed to the outer tapered end of crank-shaft D, and nut D<sup>2</sup> secures the whole. The arms B are formed by chamfering a square off front and back to the angle required by the sail, as shown.

E E are cheeks constituting the mill-head, the box, or the framing. F is the central casting, G the frame or standard, and H a lever pivoted in bearings at H<sup>1</sup>. D<sup>1</sup> are crank-shaft bearings. H<sup>2</sup> connecting rod jointed by a bolt to radius-bar or beam H, at either H<sup>3</sup> or H<sup>4</sup>. H<sup>3</sup> is down-rod to a pump, and H<sup>6</sup> a guide roller for it. E<sup>1</sup> are bolts securing the upper and lower halves of the cheeks together, and the whole to the central casting F. F<sup>1</sup> is foot in step F<sup>2</sup> secured to frame or standard G.

I is the vane fixed in frame I<sup>1</sup>, which has projecting arms hinged by bolts I<sup>2</sup> between the bracket E<sup>3</sup> at bottom, and an extended strap E<sup>2</sup> bolted to the cheeks at top. J is a flat spring, assuming when looked at edgewise the shape of a volute, the inner end of which is firmly fixed to an arm or bracket, E<sup>4</sup>. J<sup>1</sup> is a chain or cord joining outer end of spring J and vane frame I<sup>1</sup>. J<sup>2</sup> is cord joining vane frame I<sup>1</sup> and mill-head E. J<sup>3</sup> are stays or straps, between which is pulley J<sup>4</sup>. J<sup>5</sup> is cord from frame I<sup>1</sup>, passing around pulley J<sup>4</sup> over guide roller H<sup>6</sup> to the ground. J<sup>6</sup> are stays from lower to upper part of cheeks E.

In order that this wind-wheel may be revolved by the wind, it is necessary that the vane I should be moved from the relative position shown in figure 4 to that shown in figures 1, 2, and 3, or to some relative position between the two; this is done by loosening cord J<sup>5</sup> on the ground, and allowing the vane to take the desired angle. The vane and the wheel take positions according to the wind, the latter being nearly or approximately at right angles to the direction in which it is blowing, as the vane is allowed to be drawn over less or more by spring J. Any sudden gust or too boisterous wind will now alter the relative positions by folding the vane and wheel together, and forcing the latter towards a position in which it will present its edge to the wind. When the wind ceases or abates spring J will positively return both wheel and vane to their normal relative positions with regard to the force of the wind.

As the wheel revolves, its motion, taken by crank D, is communicated by connecting rod H<sup>2</sup> to radius rod or lever H, which moves down rod H<sup>5</sup>. The stroke of said rod H<sup>5</sup> may be altered by affixing the forked end of the connecting rod H<sup>2</sup> to either of the bearings H<sup>3</sup> or H<sup>4</sup> provided in the lever H. To shorten said stroke the forked end of said connecting rod E is disconnected from radius bar H by taking out pin in bearing H<sup>4</sup> and replacing it through said forked end in bearing H<sup>3</sup> in lever H.

It is to be noticed that should any one or more of the sails A or arms B be damaged and require replacing, it may readily and easily be accomplished with only just such stoppage of the mill as is necessary to release respective bolts A<sup>2</sup> and A<sup>3</sup>, or bolts A<sup>2</sup>, C<sup>2</sup>, and C<sup>3</sup>, and again to replace them; in the meantime such damaged parts can be constructed by any ordinary rough carpenter, and the mill will be working nearly as efficiently as before while he is doing so.

Having

*Improvements in Windmills.*

Having thus described the nature of my invention, and the manner of performing same, I would have it understood that I only claim as my improvements in windmills,—

First—The combination and arrangement with the crank-shaft D of the discs or flanges C and C<sup>1</sup>, the arms B, sails A, and connecting stays A<sup>1</sup>, substantially as herein described and explained, and as illustrated in the drawings.

Second—The combination and arrangement with the central casting F of the cheeks E (in two halves, between which are bearings D<sup>1</sup>) and the bolts E<sup>1</sup>, substantially as herein described and explained, and as illustrated in the drawings.

Third—Providing two or more bearings, such as H<sup>2</sup> and H<sup>4</sup> in the radius bar or lever H, for varying the stroke of the down-rod, substantially as herein described and explained, and as illustrated in the drawings.

Fourth—The combination and arrangement with a mill-head and a folding vane of a spring for returning the vane to its normal position.

In witness whereof, I, the said Josiah Earl, have hereto set my hand and seal, this twenty-seventh day of August, one thousand eight hundred and eighty-three.

EDWD. WATERS, 6, Bridge-street, Sydney,  
Agent for Applicant.

JOSIAH EARL,  
(By his Agent, FRED. WALSH).

This is the specification marked A referred to in the annexed Letters of Registration granted to Josiah Earl, this seventeenth day of November, A.D. 1883.

AUGUSTUS LOFTUS.

---

REPORT.

Sir,

In reply to your B.C. minute of the 29th August, enclosing application from Mr. Josiah Earl for Letters of Registration for "Improvements in Windmills," we have to report that we are of opinion that the prayer of such Petition might be complied with.

Sydney, 15 September, 1883.  
We have, &c.,  
JAMES BARNET.  
WILLIAM C. BENNETT.

The Under Secretary of Justice.

---

[Drawings—one sheet.]

J. EARL'S PATENT.

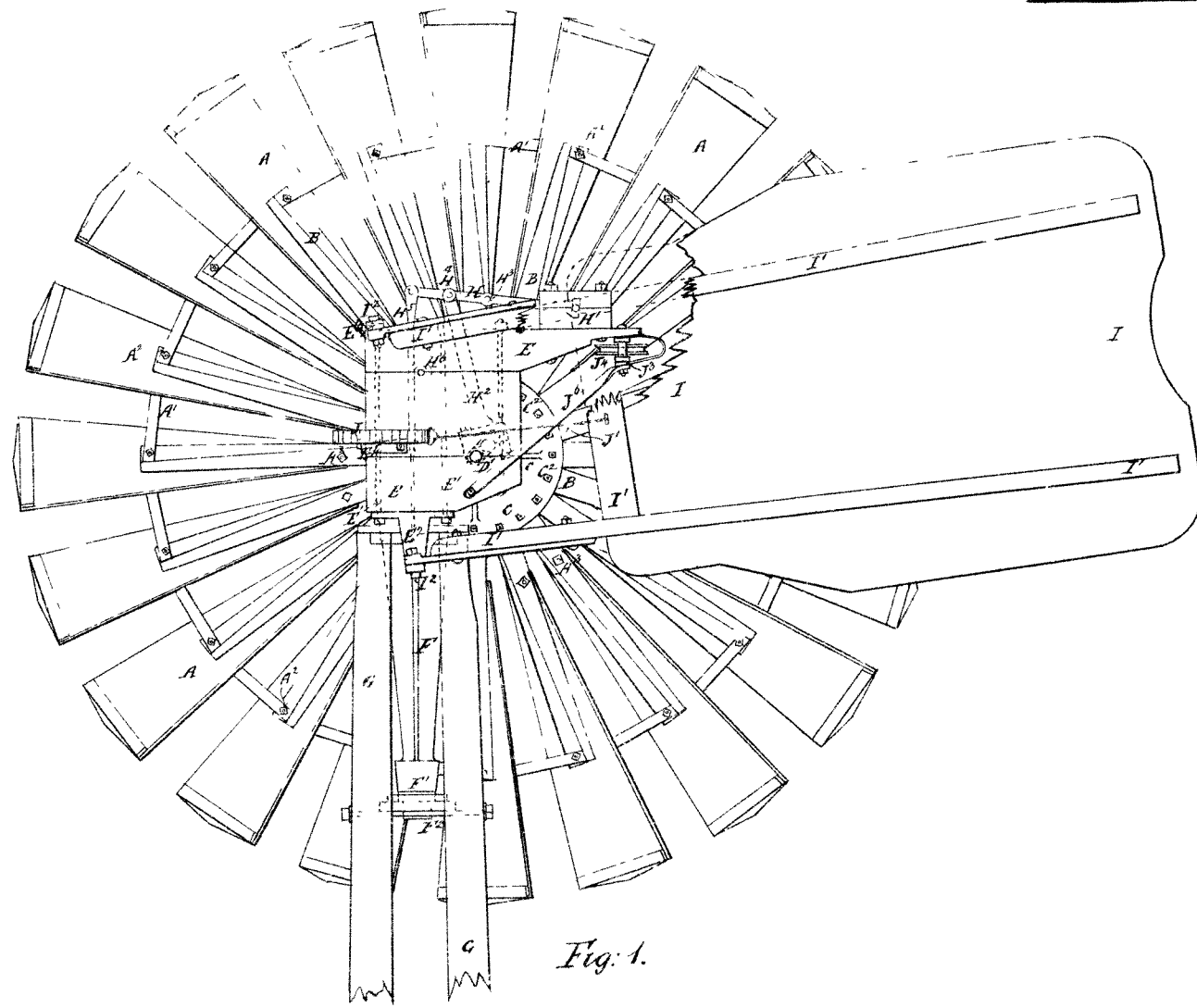


Fig. 1.

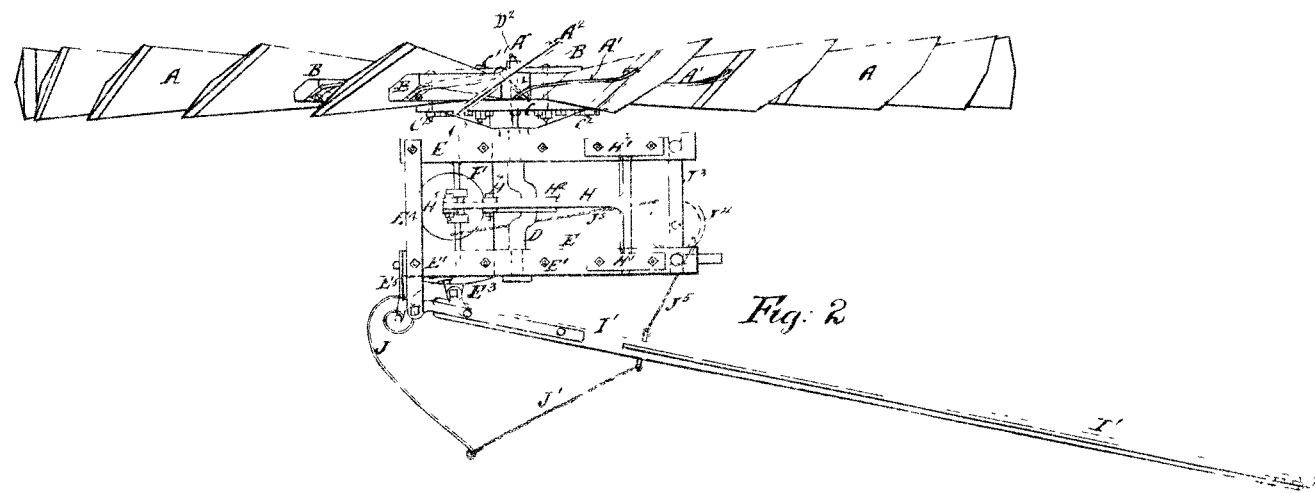


Fig. 2.

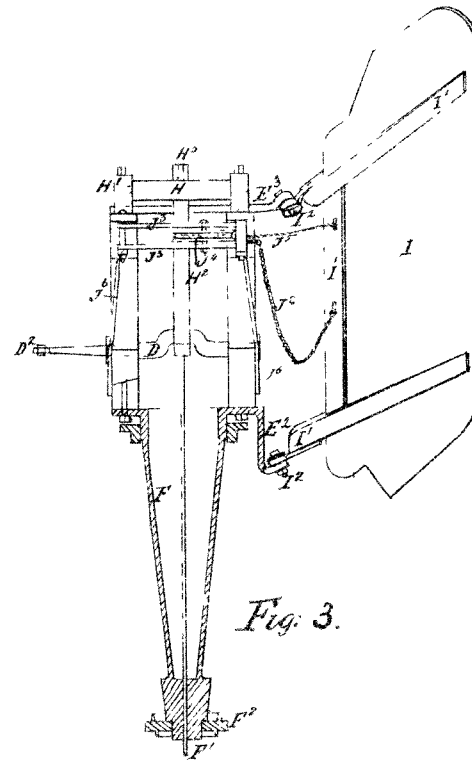


Fig. 3.

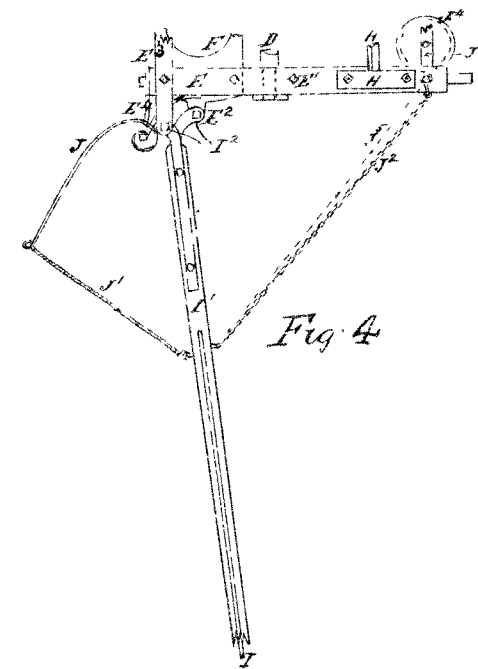


Fig. 4.

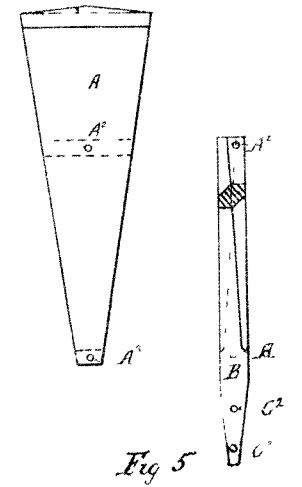


Fig. 5.

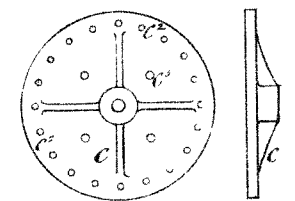


Fig. 6.

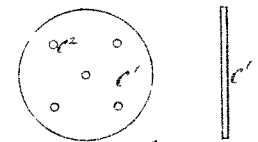


Fig. 7.

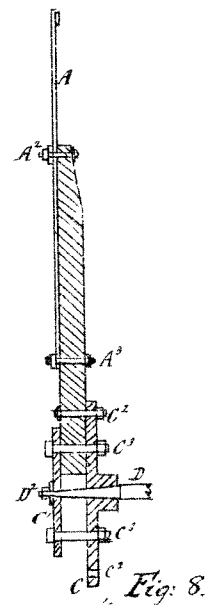


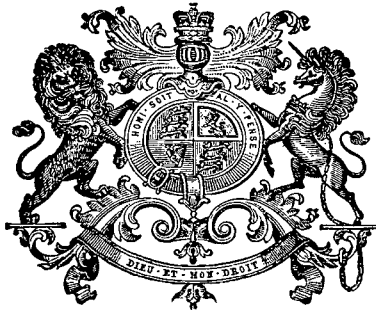
Fig. 8.

(Sig. 35.)

This is the Sheet of Drawings marked *Preferred* in the annexed Letters of Registration, granted to Josiah Earl this 11<sup>th</sup> day of November A.D. 1883.

Augustus Loftus.

PHOTO-LITHOGRAPHED AT THE GOVT. PRINTING OFFICE SYDNEY NEW SOUTH WALES



A.D. 1883, 17th November. No. 1338.

A NEW OR IMPROVED COMPOUND FOR LUBRICATING MACHINERY.

LETTERS OF REGISTRATION to William Adam Dixon and Robert Saddington,  
for a New or Improved Compound for Lubricating Machinery.

[Registered on the 19th day of November, 1883, in pursuance of the Act 16 Vic. No. 24.]

BY HIS EXCELLENCY THE RIGHT HONORABLE SIR AUGUSTUS WILLIAM FREDERICK SPENCER LOFTUS (commonly called LORD AUGUSTUS LOFTUS), Knight Grand Cross of the Most Honorable Order of the Bath, a Member of Her Majesty's Most Honorable Privy Council, Governor and Commander-in-Chief of the Colony of New South Wales and its Dependencies.

TO ALL TO WHOM THESE PRESENTS SHALL COME, greeting :

WHEREAS WILLIAM ADAM DIXON, of Pitt-street, Sydney, chemist, and ROBERT SADDINGTON, of Barrack-street, Sydney, Chairman of the Kerosene Oil and Mineral Company of New South Wales (Limited), have by their Petition humbly represented to me that they are the authors or designers of a certain invention or improvement in manufactures, that is to say, of an invention entitled "A New or Improved Compound for Lubricating Machinery," which is more particularly described in the specification which is hereunto annexed ; and that they, the said Petitioners, have deposited with the Honorable the Treasurer of the said Colony of New South Wales the sum of Twenty Pounds sterling, for defraying the expense of granting these Letters of Registration, as required by the Act of Council, sixteenth Victoria, number twenty-four, and have humbly prayed that I would be pleased to grant Letters of Registration whereby the exclusive enjoyment and advantage of the said invention or improvement might be secured to them for a period of fourteen years : And I, being willing to give encouragement to all inventions and improvements in the arts or manufactures which may be for the public good, and having received a report favourable to the prayer of the said Petition from competent persons appointed by me to examine and consider the matters stated therein and to report thereon for my information, am pleased, with the advice of the Executive Council, and in exercise of the power and authority given to me by the said Act of Council to grant, and do by these Letters of Registration grant unto the said William Adam Dixon and Robert Saddington, their executors, administrators, and assigns, the exclusive enjoyment and advantage of the said invention or improvement for and during the term of fourteen years from the date hereof ; to have, hold, and exercise unto the said William Adam Dixon and Robert Saddington, their executors, administrators, and assigns, the exclusive enjoyment and advantage thereof, for and during and unto the full end and term of fourteen years from the date of these presents next and immediately ensuing, and fully to be complete and ended Provided always, that if the said William Adam Dixon and Robert Saddington shall not, within three days after the granting of these Letters of Registration, register the same in the proper office in the Supreme Court, at Sydney, in the said Colony of New South Wales, then these Letters of Registration, and all advantages whatsoever hereby granted, shall cease and become void.

In witness whereof, I have hereunto set my sign manual, and have caused the present Letters of Registration to be sealed with the seal of the said Colony of New South Wales, at Government House, Sydney, in New South Wales, this seventeenth day of November, in the year of our Lord one thousand eight hundred and eighty-three.

[L.s.]

AUGUSTUS LOFTUS.

*A New or Improved Compound for Lubricating Machinery.*

WE, WILLIAM ADAM DIXON and ROBERT SADDINGTON, of Sydney, do hereby declare the nature of our invention for the manufacture of lubricating oils from mineral oils by the solution in them of ordinary colophony or resin, and for making grease from such mixture by the addition of milk of lime. The use of the oil so manufactured is for the lubrication of machinery of every description, and of woollen stuff in process of manufacture. The use of the grease is for the lubrication of axles or parts of machinery running at low speed, and is especially applicable to machinery working under water or in wet places.

In carrying out our invention we use any mineral oil or oil distilled from shale or coal, either in the crude state or refined, but we prefer the heavier oil obtained as a residue in the manufacture of kerosene, either crude or refined, and hereafter designated along with the others mineral oil. We dissolve in the mineral oil ordinary colophony or resin, either in the cold or by the application of a gentle heat, such a proportion of resin as will communicate the requisite viscosity to the product being used.

In actual practice we find it most convenient to make only one such solution of resin containing 50 per cent., as a thicker oil is seldom required, and this may be thinned to any extent by the addition of mineral oil.

In carrying out the manufacture we place 100 gallons of mineral oil in a suitable vessel provided with paddles worked by hand or machinery, and heat it to a temperature of 150° Fahrenheit or thereabouts, and stir into it 1,000 pounds weight of resin in coarse powder, continuing the stirring until the resin is dissolved. The exact temperature is not of much importance, so that it is so low as to prevent decomposition of the resin. On cooling, the solution forms a thick oil, which we use on such bearings as are usually supplied with castor oil; we therefore call it castor oil substitute. We find that this combination possesses the advantage over mineral oil alone that it will mix not only with mineral oil but with any vegetable or animal oil or fat in any proportion, including castor oil, which does not mix with mineral oil. It will also mix with soap or semi-saponified fats and water, to form axle grease similar to that usually made from palm oil. We use such mixtures as the following:—

One part of castor oil substitute mixed with one part of mineral oil forms a good lubricant for light machinery.

One part of castor oil substitute mixed with two parts of mineral oil forms a lubricant for light spindles, and can be applied to woollen goods during their manufacture in place of olive or other expensive oils. It can readily be removed from such goods by soap and water, and is not liable to spontaneous combustion, as is the case with vegetable and animal oils.

We make a superior axle grease by mixing in a copper or suitable vessel, to which heat can be applied by steam or fire, one part of tallow, one part of castor oil substitute, two parts of mineral oil, two parts of water, and one-half part of caustic soda in powder, or the same proportion dissolved in the water. The mixture is heated till it boils, when the source of heat is withdrawn, and the mixture is stirred from time to time till it cools.

To manufacture ordinary cart-grease, we place (say) 30 gallons of castor oil substitute in a vessel provided with a stirring apparatus, and mix with it 70 gallons of mineral oil, and then add, with continued stirring, a milk of lime made by suspending 155 pounds weight of finely divided lime in 90 gallons of water, and continue the agitation until the whole is converted into a butter-like mass. The use of a large proportion of castor oil substitute and lime will form a harder grease whilst the above may be thinned with mineral oil, if required. We prefer to use lime that has been freed from gritty particles by elutriation in water.

Having now declared the nature of our invention, we wish it to be understood that we do not claim any particular proportions of materials or temperature, or any particular apparatus. Our claims are—

- 1st. For the manufacture of lubricating oils by dissolving ordinary colophony or resin in mineral oils.
- 2nd. For the combination of vegetable or animal oils or fats, or of soap or semi-saponified fats or oils, with mineral oil, through the intervention of resin.
- 3rd. For the manufacture of cart-grease by the addition of milk of lime to a solution of resin in mineral oil.
- 4th. For the use of these compounds for lubricating machinery.

WILL. A. DIXON.  
ROBT. SADDINGTON.

This is the specification referred to in the annexed Letters of Registration granted to William Adam Dixon and Robert Saddington, this 17th day of November, 1883.

AUGUSTUS LOFTUS.

---

REPORT.

---

Sir,

In reply to your B.C. minute of the 8th instant, enclosing application from Messrs. Dixon and Saddington for Letters of Registration for "An improved compound for lubricating machinery, to be called 'Castor Oil Substitute,'" we have to report that we are of opinion that the prayer of such Petition might be complied with.

We have, &c.,

JAMES BARNET.  
WILLIAM C. BENNETT.

The Under Secretary of Justice.

---



A.D. 1883, 17th November. No. 1339.

ROBERT A. CHESNEY'S DUNLOP EARTH-SCOOP.

LETTERS OF REGISTRATION to Robert A. Chesney, for Robert A. Chesney's Dunlop Earth-scoop.

[Registered on the 19th day of November, A.D. 1883, in pursuance of the Act 16 Vic. No. 24.]

BY HIS EXCELLENCY THE RIGHT HONORABLE SIR AUGUSTUS WILLIAM FREDERICK SPENGER LOFTUS (commonly called LORD AUGUSTUS LOFTUS), Knight Grand Cross of the Most Honorable Order of the Bath, a Member of Her Majesty's Most Honorable Privy Council, Governor and Commander-in-Chief of the Colony of New South Wales and its Dependencies.

TO ALL TO WHOM THESE PRESENTS SHALL COME, greeting :

WHEREAS ROBERT A. CHESNEY, of Dunlop Station, River Darling, in the Colony of New South Wales, hath by his Petition humbly represented to me that he is the author or designer of a certain invention or improvement in manufactures, that is to say, of an invention entitled "Robert A. Chesney's Dunlop Earth-scoop," which is more particularly described in the specification, marked A, and the three sheets of drawings, marked B, C, and D respectively, which are hereto annexed; and that he, the said Petitioner, hath deposited with the Honorable the Treasurer of the said Colony of New South Wales the sum of Twenty Pounds sterling, for defraying the expense of granting these Letters of Registration, as required by the Act of Council, sixteenth Victoria, number twenty-four; and hath humbly prayed that I would be pleased to grant Letters of Registration, whereby the exclusive enjoyment and advantage of the said invention or improvement might be secured to him for a period of fourteen years: And I, being willing to give encouragement to all inventions and improvements in the arts or manufactures which may be for the public good, and having received a report favourable to the prayer of the said Petition, from competent persons appointed by me to examine and consider the matters stated therein and to report thereon for my information, am pleased, with the advice of the Executive Council, and in exercise of the power and authority given to me by the said Act of Council, to grant, and do by these Letters of Registration grant unto the said Robert A. Chesney, his executors, administrators, and assigns, the exclusive enjoyment and advantage of the said invention or improvement, for and during the term of fourteen years from the date hereof; to have, hold, and exercise unto the said Robert A. Chesney, his executors, administrators, and assigns, the exclusive enjoyment and advantage thereof, for and during and unto the full end and term of fourteen years from the date of these presents next and immediately ensuing, and fully to be complete and ended: Provided always, that if the said Robert A. Chesney shall not, within three days after the granting of these Letters of Registration, register the same in the proper office in the Supreme Court, at Sydney, in the said Colony of New South Wales, then these Letters of Registration, and all advantages whatsoever hereby granted, shall cease and become void.

In witness whereof, I have hereunto set my sign manual, and have caused the present Letters of Registration to be sealed with the seal of the said Colony of New South Wales, at Government House, Sydney, in New South Wales, this seventeenth day of November, in the year of our Lord one thousand eight hundred and eighty-three.

[L.S.]

AUGUSTUS LOFTUS.



*Robert A. Chesney's Dunlop Earth-scoop.*

## A.

TO ALL TO WHOM THESE PRESENTS SHALL COME: I, ROBERT A. CHESNEY, of Dunlop Station, River Darling, New South Wales, send greeting:—

WHEREAS I am desirous of obtaining Letters of Registration for securing unto me Her Majesty Special License that I, my executors, administrators, and assigns, and such others as I or they shall at any time agree with, and no others, shall and lawfully may, from time to time and at all times, during the period of fourteen years, to be computed from the day on which this instrument shall be left at the office of the Minister for Justice, Sydney, make, use, exercise, and vend within the Colony of New South Wales, an invention of an Improved Earth-scoop by means of which earth and other like materials are excavated, as more fully and particularly described in the following specification and set forth in the accompanying drawings.

## SPECIFICATION.

THE object of my invention is the excavation by horse-power of earth, sand, and like materials when required in the formation of dams, waterholes, reservoirs, cuttings, and embankments for roads, railways, and other similar works, in an expeditious and efficient manner, and at less cost than can be accomplished by other known means.

The make of the scoop is as follows:—It consists of a strong frame of angle iron with the spaces filled up of light iron, so as to form panels combining strength and lightness, instead of being, as all other scoops now in use are, made of iron of one thickness throughout.

## DESCRIPTION.

Figure 1 represents a side view of the machine; the two front wheels and the hind wheel, which are wooden, and of ordinary make, are fitted with boxes; the hind wheel is so arranged that it can turn upon its own vertical axle, thereby allowing the machine to turn at right angles if necessary. All the rest of the machine is constructed of iron.

## MODUS OPERANDI.

*Raising the Scoop.*—This is done by bringing two clutch castings (*a*, figures II and III) together—one casting being a fixture to the wheel, the other being keyed longitudinally to the axle (*b*, figures II and III), so that it can be moved along the axle either into or out of gear.

*Putting it into gear* makes it a fixture to the wheel for the time being, which when moved turns the axle round; the revolution of the wheel therefore by the draft of the horses, the motive-power, sets the whole machine in operation. Attached to the axle are two chains, which are fixed on to each axle of the scoop (*c*, figure I) so that the scoop is raised by the axle (*b*, figures II and III) being turned; when the scoop is high enough, a small arm (which is a fixture to the axle) is caught by a steel bolt, acted on by a spring, which makes the axle a fixture until the spring may be withdrawn; meantime the clutch castings, on account of their shape, throw themselves out of gear (arm and steel bolt and foot lever, as shown as *e* and *d*, figure III). The arms of figure I keep the scoop in position, and by altering rack (*h*, figure I) the dip of the scoop can be regulated. In these arms are shown the slots, to allow longitudinal play room for the two fixed points of the scoop, viz:—For car (*j*, figure I) and the axle of scoop (*c*, figure I). *ff*, figure I, are the guides that keep the scoop in position and allow of its vertical motion. *K*, figure I, is an arrangement for regulating the depth of the scoop by shifting it either up or down, as the case may be. *L*, figure I, representing door, which is self-acting, as when the scoop falls being attached by a wire rope (going over the large axle) to the back of the scoop, the door is thereby raised, and, *vice versa*, the door falls again; attached to the door are two racks, into which fit two cog-wheels joined by one axle, so that this door falls evenly, that is, one side cannot come down faster than the other, as shown in figures I and II.

*Lowering of the Scoop.*—This is done by putting the left foot on the lever (*d*, figure III), and withdrawing the bolt from the fixed arm, so that the axle is free to revolve, which thereby allows the scoop to descend until the axles of the scoop rest on *K*, figure I. Unloading: To accomplish this there are three doors—one behind (*o*, figure III) and two in the bottom (*M* and *N*, figure IV); the hind one is on hinges, and is constantly kept shut by an indiarubber spring, *P* (figures I, III, & IV), and can be opened by rod attached to lever at *P*. A small catch keeps up door *M*, which in its turn keeps up door *N*, and when back door is drawn out the bottom doors drop, and the contents of the scoop are deposited. Doors *M* and *N* are each on an axle, the bearings of which are inside the scoop.

*Raising the Doors.*—This is done by two chains attached to a lever (*R*, figure I), while the other ends of the chains are attached to two small levers joined to the axles of the bottom doors on the outside. When lever *R* is lifted, door *N* rises first, then *M* next, which latter hits against a little hammer, represented by dotted line (figures I and IV), which allows back door to spring into its original position and sustain door *M* by means of its catches.

## ADVANTAGES.

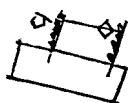
Although the advantage and novelty of the arrangements and devices are really sufficiently clear from the description already given in the specification showing the manner of the operation of the invention, I proceed now more specifically to state the advantage of my invention.

First—The scoop is the only three-wheeled one having one wheel behind, by which it can operate at right angles, and on this account the scoop is brought as close as possible to the motive power, the horses thereby saving power.

Second—There is no tumbling over, which jars and is severe on machinery, as well as on the horses having to roll it over. This is the only scoop in which the unloading is done by the bottom dropping out, a method which always keeps the embankment level, as the earth is distributed in layers instead of being deposited in heaps; this also makes the work easier for the horses.

Third—The self-acting door is different from any yet made, in being a straight drop instead of working on a hinge (as all other scoops with doors do) it falls more rapidly there by saving more loose earth.

Fourth



*Robert A. Chesney's Dunlop Earth-scoop.*

Fourth—On the point of the pole is a self-acting hook, by which extra horses can be attached for filling the scoop, and when once the scoop is filled and the strain of the extra horses taken off the chains drop off automatically, thus

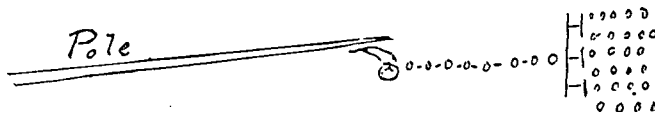


Figure 1 here represents the hook, and figure 2 the chain; when the large link is put on the hook it will remain on so long as a fair strain is kept on it, but immediately that the strain is taken off and the chain "sags" it drops on the little wheel, which turns round and allows the chain to drop to the ground.

Having now described my invention and detailed its *modus operandi* and its advantages, with the features of novelty therein, I claim generally the whole of the machine in combination and its several parts, but more especially I claim,—

First—The arrangement by which the doors discharge automatically the load, and the avoidance thereby of the ordinary "tumbling over," which jars severely, both machinery and horses, with the distribution also of the load in layers instead of heaps.

Second—The pole arrangement with self-acting hook, for increasing the motive power on emergency, and the automatic release thereof.

These advantages and novelties of invention I claim as substantially described and set forth herein and as illustrated in the accompanying drawings.

ROBERT A. CHESNEY,  
(*Per* HENRY HALLORAN, Patent Agent).

2, Wentworth Court, 21st March, 1883.

This is the specification marked A referred to in the annexed Letters of Registration granted to Robert A. Chesney, this seventeenth day of November, A.D. 1883.

AUGUSTUS LOFTUS.

### REPORTS.

Sir,

Sydney, 7 May, 1883.

In accordance with your B.C. minute of the 22nd March, forwarding application of R. A. Chesney for Letters of Registration for an invention entitled "The Dunlop Earth-scoop," we have to report that we are of opinion that Letters of Registration might be issued protecting the general arrangement and the improvement described in the second claim for the special sort of automatic door therein described.

We have, &c.,

JAMES BARNET.  
WILLIAM C. BENNETT.

The Under Secretary of Justice.

Sir,

Sydney, 25 June, 1883.

With reference to the letter of Mr. R. A. Chesney, of 5 June, requesting reconsideration of our report on his invention entitled "The Dunlop Earth-scoop," the first claim now given up by him is simply the arrangement which has for years been in use as the ordinary Dobbin cart of excavators.

The third claim, for a self-acting hook, which is an obvious application of the well-known friction roller, and of no importance to the success of the scoop, as there are numerous self-acting contrivances to answer the same purpose without infringing that claim, which we consider may be conceded, as applicant seems to think it so important a part of his invention.

We have, &c.,

JAMES BARNET.  
WILLIAM C. BENNETT.

The Under Secretary of Justice.

Sir,

Sydney, 14 August, 1883.

With reference to the application from Mr. Halloran, on behalf of Mr. R. A. Chesney, for the granting of his petition for registration of the "Dunlop Earth-scoop" in its entirety, as we have already recommended all but the first claim for protection, we are still of opinion that protection should not be given, as the wheel in question, in addition to its general similarity to the Dobbin wheel, is not by any means new.

We have, &c.,

JAMES BARNET.  
WILLIAM C. BENNETT.

The Under Secretary of Justice.

21 September, 1883.

MEMO.—We now recommend that Letters of Registration be issued in accordance with our letter of 14th August, 1883.

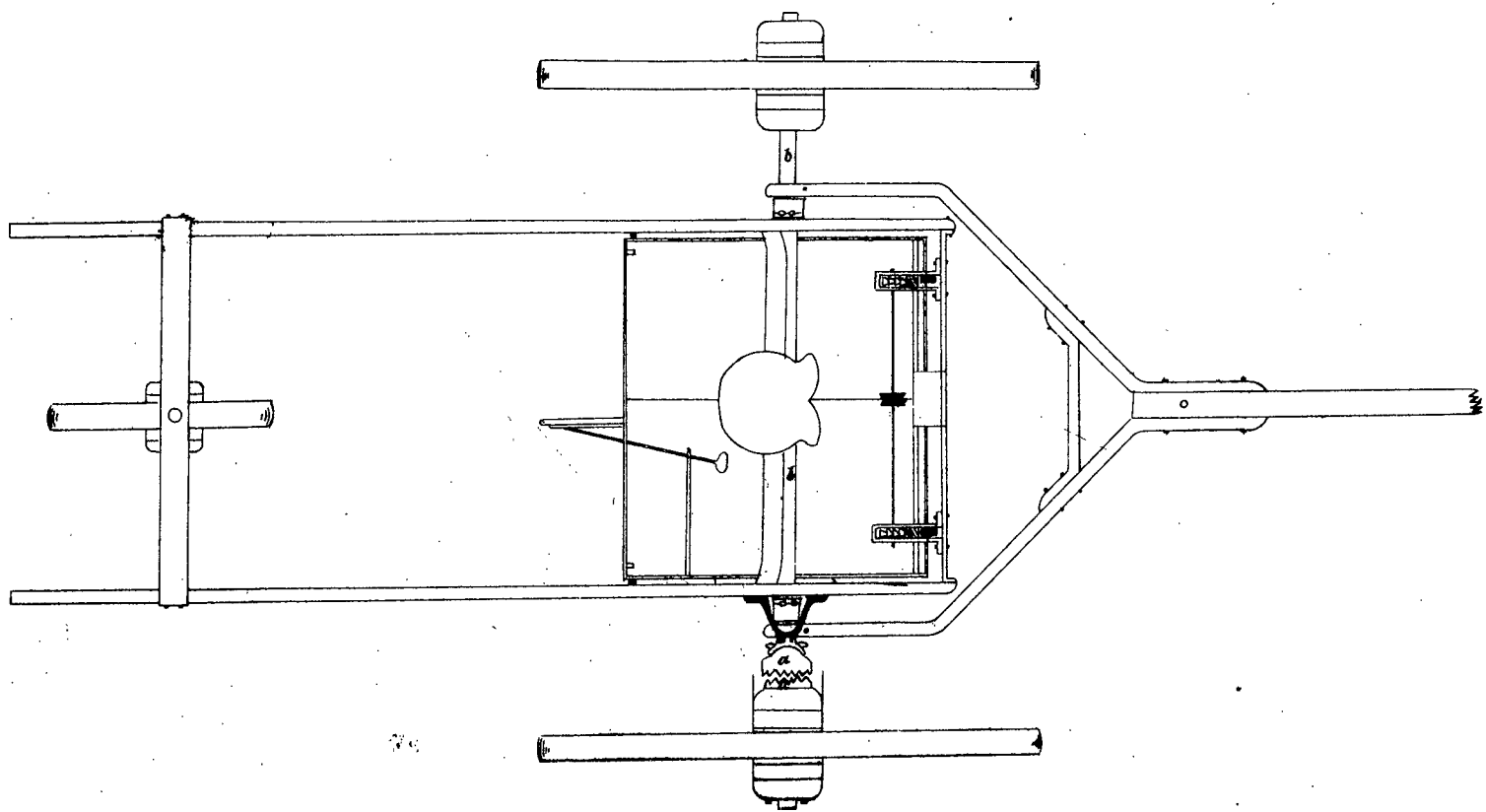
JAMES BARNET.  
WILLIAM C. BENNETT.

The Under Secretary of Justice.

B.

1339.

"B"



VIEW

*This is the Sheet of Drawings marked B. referred to in  
 the annexed Letters of Registration granted to Robert  
 A. Chesney this 17<sup>th</sup> day of November A.D. 1883.*

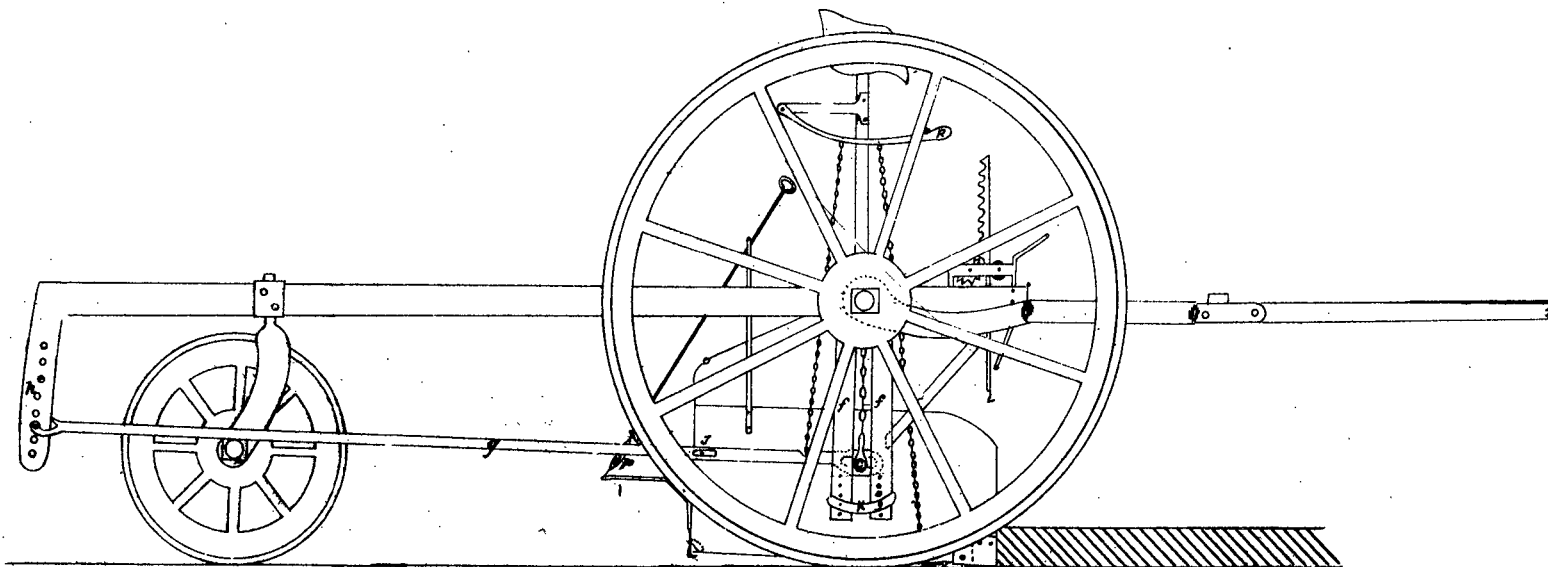
*Augustus Loftus.*

PHOTO-LITHOGRAPHED AT THE GOVT. PRINTING OFFICE,  
 SYDNEY, NEW SOUTH WALES.

*Fig. 35*

C.

1339.

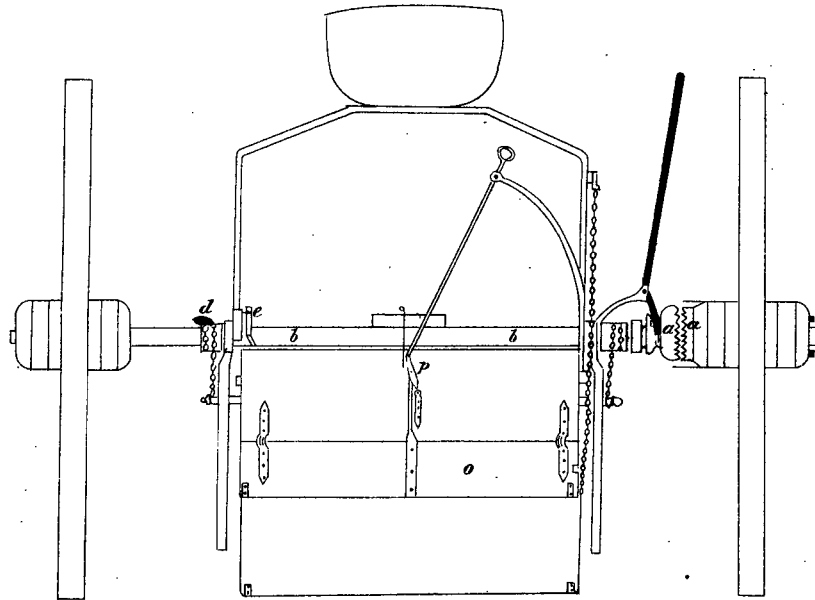


SIDE VIEW

Fig 1

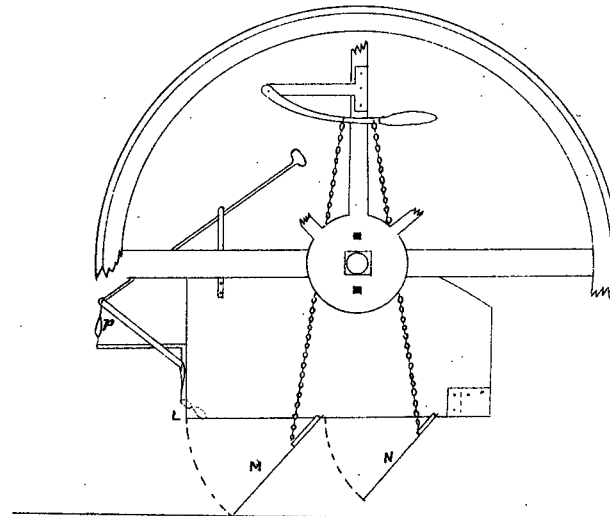
*This is the Sheet of Drawings marked C. referred to in the  
annexed Letters of Registration granted to Robert A  
Chesney, this 17<sup>th</sup> day of November, A. D. 1883.  
Augustus Loftus.*

Fig 35



B A C K V I E W

Fig III



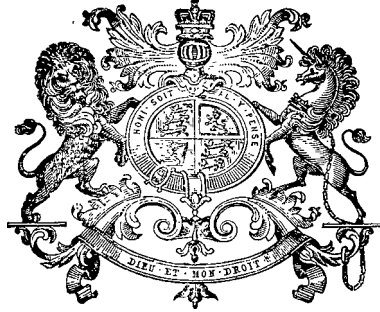
S I D E V I E W

Fig IV

*Illustrating the Unloading*

*This is the Sheet of Drawings marked D. referred to in the annexed Letters of Registration granted to Robert A Chesney, this 17<sup>th</sup> day of November A.D. 1883.*

*Augustus Loftus.*



A.D. 1883, 3rd December. No. 1340.

WHITE OR RAW-HIDE COMPOSITE MILL BAND OR BELTING.

LETTERS OF REGISTRATION to John Handley Knibbs, Frank Joseph Knibbs, and Alfred Edwin Knibbs for White or Raw-hide Composite Mill Band or Belting.

[Registered on the 6th day of December, 1883, in pursuance of the Act 16 Vic. No. 24.]

BY HIS EXCELLENCY THE RIGHT HONORABLE SIR AUGUSTUS WILLIAM FREDERICK SPENCER LOFTUS (commonly called LORD AUGUSTUS LOFTUS), Knight Grand Cross of the Most Honorable Order of the Bath, a Member of Her Majesty's Most Honorable Privy Council, Governor and Commander-in-Chief of the Colony of New South Wales and its Dependencies.

TO ALL TO WHOM THESE PRESENTS SHALL COME, greeting:

WHEREAS JOHN HANDLEY KNIBBS, FRANK JOSEPH KNIBBS, and ALFRED EDWIN KNIBBS, trading as J. H. Knibbs & Sons, of 9, Wharf-street, Market Wharf, Sydney, in the Colony of New South Wales, have by their Petition humbly represented to me that they are the authors or designers of a certain invention or improvement in manufactures, that is to say, of an invention entitled "White or Raw-hide Composite Mill Bands or Belting," which is more particularly described in the specification with plan hereunto annexed; and that they, the said Petitioners, have deposited with the Honorable the Treasurer of the said Colony of New South Wales the sum of Twenty Pounds sterling, for defraying the expense of granting these Letters of Registration, as required by the Act of Council, sixteenth Victoria, number twenty-four; and have humbly prayed that I would be pleased to grant Letters of Registration, whereby the exclusive enjoyment and advantage of the said invention or improvement might be secured to them for a period of fourteen years: And I, being willing to give encouragement to all inventions and improvements in the arts or manufactures which may be for the public good, and having received a report favourable to the prayer of the said Petition, from competent persons appointed by me to examine and consider the matters stated therein and to report thereon for my information, am pleased, with the advice of the Executive Council, and in exercise of the power and authority given to me by the said Act of Council, to grant, and do by these Letters of Registration grant unto the said John Handley Knibbs, Frank Joseph Knibbs, and Alfred Edwin Knibbs, their executors, administrators, and assigns, the exclusive enjoyment and advantage of the said invention or improvement, for and during the term of fourteen years from the date hereof; to have, hold, and exercise unto the said John Handley Knibbs, Frank Joseph Knibbs, and Alfred Edwin Knibbs, their executors, administrators, and assigns, the exclusive enjoyment and advantage thereof, for and during and unto the full end and term of fourteen years from the date of these presents next and immediately ensuing, and fully to be complete and ended: Provided always, that if the said John Handley Knibbs, Frank Joseph Knibbs, and Alfred Edwin Knibbs shall not, within three days after the granting of these Letters of Registration, register the same in the proper office in the Supreme Court, at Sydney, in the said Colony of New South Wales, then these Letters of Registration, and all advantages whatsoever hereby granted, shall cease and become void.

In witness whereof, I have hereunto set my sign manual, and have caused the present Letters of Registration to be sealed with the seal of the said Colony of New South Wales, at Government House, Sydney, in New South Wales, this third day of December, in the year of our Lord one thousand eight hundred and eighty-three.

[L.S.]

[AUGUSTUS LOFTUS.]

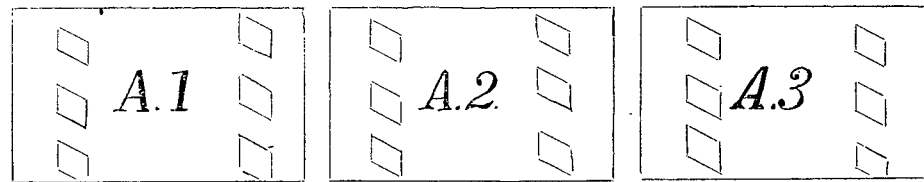
*White or Raw-hide Composite Mill Bands or Belting.*

SPECIFICATION and Drawing of a White or Raw-hide Composite Mill Band or Belting for which Letters of Registration are applied by JOHN HANDLEY KNIBBS, FRANK JOSEPH KNIBBS, and ALFRED EDWIN KNIBBS, trading as J. H. Knibbs & Sons, of 9, Wharf-street, Sydney, New South Wales.

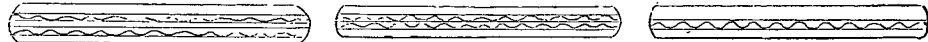
THE said bands are manufactured with one or more plies or layers of best canvas and two or more plies or layers of white or raw-hide leather. The said leather is specially prepared and undergoes a process of "stuffing" in the course of manufacture. These bands are in all cases cemented and thong sewn, which unite the whole of the parts, making one compact and solid strap, as shown in drawing at bottom and samples accompanying.

We claim for this make originality in its composition and construction, being stronger than all other kinds of mill-belting. The material and manner of make give it great strength, equal softness and pliability, and greater gripping power on the pulleys than all other kinds.

## PLAN.



## SECTION.



A1.—Three plies of leather and two of canvas.

A2.—Two plies of leather and two of canvas.

A3.—Two plies of leather and one of canvas.

JOHN HANDLEY KNIBBS.  
FRANK JOSEPH KNIBBS.  
ALFRED EDWIN KNIBBS.

Sydney, 12th September, 1883.

This is the specification with plan referred to in the annexed Letters of Registration, granted to John Handley Knibbs, Frank Joseph Knibbs, and Alfred Edwin Knibbs, this third day of December, A.D. 1883.

AUGUSTUS LOFTUS.

## REPORT.

Sir, . . . The application of Messrs. J. H. Knibbs and Sons for Letters of Registration for an invention of "A new make of Mill-belts" having been referred to us, we have examined the specification, drawing, and samples accompanying the same, and have now the honor to report that we see no objection to the issue of Letters of Registration as prayed for.

The Under Secretary of Justice.

Sydney, 25 September, 1883.

We have, &c.,

JAMES BARNET.  
EDMUND FOSBERY.



A.D. 1883, 3rd December. No. 1341.

IMPROVEMENTS IN APPLYING ZINC FOR PREVENTING CORROSION IN  
STEAM-BOILERS.

LETTERS OF REGISTRATION to James Ballantyne Hannay, for Improvements  
in applying Zinc for preventing Corrosion in Steam-boilers.”

[Registered on the 6th day of December, 1883, in pursuance of the Act 16 Vic. No. 24.]

BY HIS EXCELLENCY THE RIGHT HONORABLE SIR AUGUSTUS WILLIAM FREDERICK SPENCER LOFTUS  
(commonly called LORD AUGUSTUS LOFTUS), Knight Grand Cross of the Most Honorable Order of  
the Bath, a Member of Her Majesty's Most Honorable Privy Council, Governor and Commander-in-  
Chief of the Colony of New South Wales and its Dependencies.

TO ALL TO WHOM THESE PRESENTS SHALL COME, greeting :

WHEREAS JAMES BALLANTYNE HANNAY, of Glasgow, in the county of Larnak, Scotland, has by his Petition humbly represented to me that he is the author or designer of a certain invention or improvement in manufactures, that is to say, of an invention entitled “Improvements in applying Zinc for preventing Corrosion in Steam-boilers,” which is more particularly described in the specification and the sheet of drawings which are hereunto annexed, and marked A and B respectively; and that he, the said Petitioner, has deposited with the Honorable the Treasurer of the said Colony of New South Wales the sum of Twenty Pounds sterling for defraying the expense of granting these Letters of Registration as required by the Act of Council sixteenth Victoria, number twenty-four, and hath humbly prayed that I would be pleased to grant Letters of Registration whereby the exclusive enjoyment and advantage of the said invention or improvement might be secured to him for a period of fourteen years. And I, being willing to give encouragement to all inventions and improvements in the arts or manufactures which may be for the public good, and having received a report favourable to the prayer of the said Petition, from competent persons appointed by me to examine and consider the matters stated therein and to report thereon for my information, am pleased, with the advice of the Executive Council, and in exercise of the power and authority given to me by the said Act of Council, to grant, and do, by these letters of Registration, grant unto the said James Ballantyne Hannay, his executors, administrators, and assigns, the exclusive enjoyment and advantage of the said invention or improvement for and during the term of fourteen years from the date hereof; to have, hold, and exercise unto the said James Ballantyne Hannay, his executors, administrators, and assigns, the exclusive enjoyment and advantage thereof for and during and unto the full end and term of fourteen years from the date of these presents next and immediately ensuing, and fully to be complete and ended: Provided always, that if the said James Ballantyne Hannay shall not, within three days after the granting of these Letters of Registration, register the same in the proper office in the Supreme Court, at Sydney, in the said Colony of New South Wales, then these Letters of Registration, and all advantages whatsoever hereby granted, shall cease and become void.

In witness whereof, I have hereunto set my sign manual, and have caused the present Letters of Registration to be sealed with the seal of the said Colony of New South Wales, at Government House, Sydney, in New South Wales, this third day of December, in the year of our Lord one thousand eight hundred and eighty-three.

[L.S.]

AUGUSTUS LOFTUS.



*Improvements in applying Zinc for preventing Corrosion in Steam-boilers.*

A.

TO ALL TO WHOM THESE PRESENTS SHALL COME: I, JAMES BALLANTYNE HANNAY, of Glasgow, in the county of Lanark, Scotland, send greeting:

WHEREAS I am desirous of obtaining Letters of Registration for the Colony of New South Wales, securing unto me Her Majesty's special license that I, my executors, administrators, and assigns, and such others as I or they should at any time agree with, and no others, should and lawfully might from time to time, and at all times during the term of fourteen years next and immediately after the date of the said Letters of Registration, make, use, exercise, and vend within the said Colony of New South Wales, an invention for "Improvements in applying Zinc for preventing Corrosion in Steam-boilers"; and whereas, in order to obtain such Letters of Registration, I must, by an instrument or specification in writing, under my hand and seal, particularly describe and ascertain the nature of the said invention, and in what manner the same is to be performed. Now know ye that the nature of the said invention, and the manner in which the same is to be performed, is particularly described and ascertained in and by the following statement in writing, reference being had to the accompanying drawings, that is to say:—

My said invention relates to the prevention of corrosion in steam-boilers, and consists in applying zinc for that purpose in an improved manner, the object being to obtain a more efficient and reliable anti-corrosive action than heretofore without waste of zinc.

When zinc is used in steam-boilers as an anti-corrosive agent it becomes itself corroded through its mass, and when employed in the form of plates or other comparatively thin extended form it rapidly disintegrates, and portions become detached from the main body. I believe that the maintenance of a proper and sufficient metallic connection between the zinc and the shell or other part of the boiler is essential, or at any rate of great importance, for the obtainment of the desired anti-corrosive or protective action; and to secure this result the zinc is, by my invention, applied in blocks or masses, which are of a spherical, or spheroidal, or polyhedral, or cubical form, or other form, having but small difference of thickness in different directions, preference being given to the simple spherical form. Each sphere or block is by preference 3 inches or more in diameter, and has a wire metallically united to it, so as to extend to or beyond its centre, the union being effected by casting the block upon the wire, or in some other sufficient manner. The wire, which may be of copper, or of other suitable metal or alloy which is a good conductor of electricity, has its other end attached, by soldering or brazing, or other equivalent means, to the shell or tubes, or other part of the boiler which it is wished to protect from corrosion. The spheres or blocks are placed in the water in the boiler in any convenient situation, and are suspended or supported in any convenient way, but by preference not by means of the conducting wires. The blocks or masses of zinc are cast, but in order to render them more durable and efficient they are subsequently brought into the condition known as malleable. For this purpose the masses are hammered, or forcibly pressed or rolled, the operation being by preference effected suddenly. Thus a convenient and satisfactory means for the purpose consists of a powerful screw-press, fitted with a heavy fly-wheel or heavily weighted arms, and provided with suitably shaped dies. The blocks or masses are by preference submitted to the hammering or compressing operation when heated to a temperature between 120 and 160 degrees centigrade. By a further improvement the zinc is made more susceptible of being rendered malleable by being alloyed with a small portion, say not more than 10 per centum, of lead, tin, or copper.

Figures 1 and 2 on the accompanying sheet of drawings are front and side elevations of a spherical block of zinc, as suspended in a boiler, and figure 3 is a horizontal section. In these drawings the same reference numerals are used to mark the same or like parts wherever they are repeated.

The sphere or ball, 4, of zinc is cast upon a brass core, 5, formed by preference, as shown, with projections, 6, radiating from the centre. To one end of this core, 5, there is soldered or brazed a copper wire, 7, the other end of which is soldered to the shell of the boiler. The ball 4 is suspended by means of an iron strap, 8, from one of the boiler stays, 9, the ball being held or clipped between the lower ends of the strap 8, by means of screw bolts 10, and by means of cross-pieces 11, riveted to the strap ends.

Another very convenient mode of holding the zinc ball is shown in figure 4. According to this modification the ball 4 is simply placed in a ladle, 12, having a handle, 13, which is attached to some of the tubes, 14, of the boiler by a clamping bar, 15, and screw bolts.

Having thus particularly described my said invention, and the manner of performing the same, I have to state that I do not restrict myself to the precise details herein described or delineated, but that what I believe to be novel and original, and claim as the invention which I desire to secure by Letters of Registration, is:—

The mode of applying zinc for preventing corrosion in steam-boilers in the form of blocks or masses of a spherical, or spheroidal, or polyhedral, or cubical form, or other form having small difference of thickness in different directions, and substantially as hereinbefore described.

In witness whereof, I, the said James Ballantyne Hannay, have herunto set my hand and seal, this seventeenth day of August, in the year of our Lord one thousand eight hundred and eighty-three.

Signed and sealed in the presence of,—

T. WATSON DUNCAN.  
EDMUND HUNT.

J. B. HANNAY.

This is the specification marked A referred to in the annexed Letters of Registration granted to James Ballantyne Hannay, this third day of December, A.D. 1883.

AUGUSTUS LOFTUS.

## REPORT.

Sir,

Sydney, 12 October, 1883.

In reply to your letter of the 9th instant, we have the honor to report that we have examined Mr. J. B. Hannay's application for Letters of Registration for an invention entitled "Improvements in applying Zinc for preventing Corrosion in Steam-boilers," also the specification and drawing therewith, and see no reason why his application should not be granted.

We have, &c.,

FRANCIS HIXSON.  
H. BRODERICK.

The Under Secretary of Justice.

[Drawings—one sheet.]

FIG. 1.

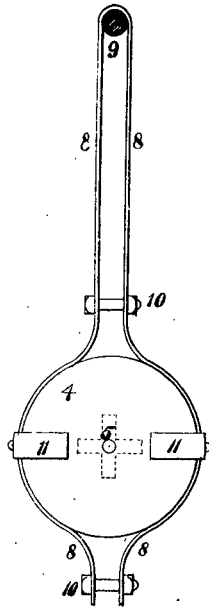


FIG. 2.

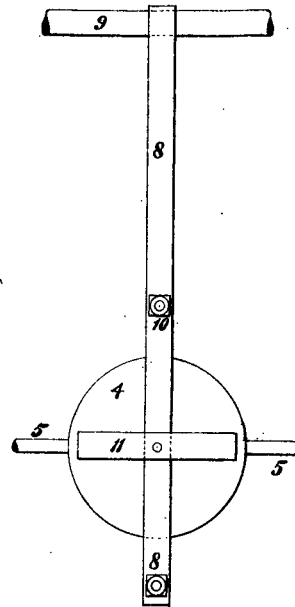


FIG. 4.

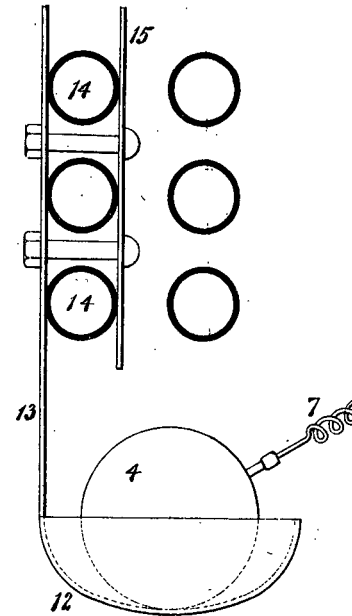
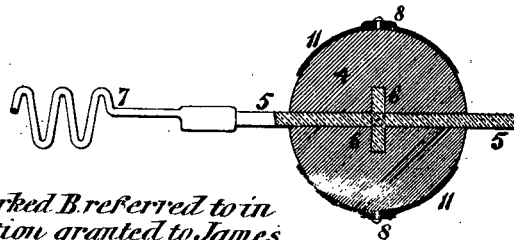
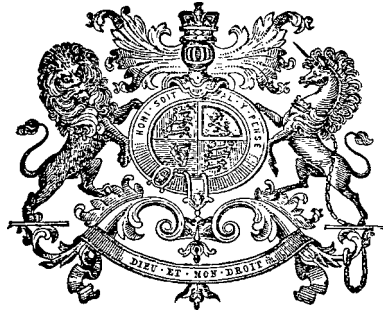


FIG. 3.



*This is the Sheet of Drawings marked B. referred to in  
 the annexed Letters of Registration granted to James  
 Ballantyne Hannay, this third day of December A.D. 1883.  
 Augustus Loftus.*

*J. Hannay*



A.D. 1883, 3rd December. No. 1342.

IMPROVEMENTS IN BARBED WIRE.

LETTERS OF REGISTRATION to Colin Mackay, Henry Walden, and Henry North, for Improvements in Barbed Wire.

[Registered on the 6th day of December, 1883, in pursuance of the Act 16 Vic. No. 24.]

BY HIS EXCELLENCY THE RIGHT HONORABLE SIR AUGUSTUS WILLIAM FREDERICK SPENCER LOFTUS (commonly called LORD AUGUSTUS LOFTUS), Knight Grand Cross of the Most Honorable Order of the Bath, a Member of Her Majesty's Most Honorable Privy Council, Governor and Commander-in-Chief of the Colony of New South Wales and its Dependencies.

TO ALL TO WHOM THESE PRESENTS SHALL COME, greeting:

WHEREAS COLIN MACKAY, engineer, HENRY WALDEN, merchant, and HENRY NORTH, gentleman, all of Dunedin, in the provincial district of Otago, in the Colony of New Zealand, have by their Petition humbly represented to me that they are the authors or designers of a certain invention or improvement in manufactures, that is to say, of an invention entitled "Improvements in Barbed Wire," which is more particularly described in the specification and the sheet of drawings which are hereunto annexed; and that they, the said Petitioners, have deposited with the Honorable the Treasurer of the said Colony of New South Wales the sum of Twenty Pounds sterling, for defraying the expense of granting these Letters of Registration, as required by the Act of Council, sixteenth Victoria, number twenty-four; and have humbly prayed that I would be pleased to grant Letters of Registration, whereby the exclusive enjoyment and advantage of the said invention or improvement might be secured to them for a period of fourteen years: And I, being willing to give encouragement to all inventions and improvements in the arts or manufactures which may be for the public good, and having received a report favourable to the prayer of the said Petition, from competent persons appointed by me to examine and consider the matters stated therein and to report thereon for my information, am pleased, with the advice of the Executive Council, and in exercise of the power and authority given to me by the said Act of Council, to grant, and do by these Letters of Registration grant unto the said Colin Mackay, Henry Walden, and Henry North, their executors, administrators, and assigns, the exclusive enjoyment and advantage of the said invention or improvement for and during the term of fourteen years from the date hereof; to have, hold, and exercise unto the said Colin Mackay, Henry Walden, and Henry North, their executors, administrators, and assigns, the exclusive enjoyment and advantage thereof for and during and unto the full end and term of fourteen years from the date of these presents next and immediately ensuing, and fully to be complete and ended: Provided always, that if the said Colin Mackay, Henry Walden, and Henry North, shall not, within three days after the granting of these Letters of Registration, register the same in the proper office in the Supreme Court, at Sydney, in the said Colony of New South Wales, then these Letters of Registration, and all advantages whatsoever hereby granted, shall cease and become void.

In witness whereof, I have hereunto set my sign manual, and have caused the present Letters of Registration to be sealed with the seal of the said Colony of New South Wales, at Government House, Sydney, in New South Wales, this third day of December, in the year of our Lord one thousand eight hundred and eighty-three.

[L.S.]

AUGUSTUS LOFTUS.

*Improvements in Barbed Wire.*

SPECIFICATON of COLIN MACKAY, engineer, HENRY WALDEN, merchant, and HENRY NORTH, gentleman, all of Dunedin, in the provincial district of Otago, in the Colony of New Zealand, for an invention entitled "Improvements in Barbed Wire."

Our invention of improvements in barbed wire consists in twisting together two longitudinal or main wires on each of which two pointed wire barbs have been previously coiled at equal and regular intervals, so that when the two longitudinal wires are twisted together the barbs on the one will come into juxtaposition with and butt up against the barbs on the other, whilst the points of the barbs on the one wire will point in an opposite direction to those on the other, and thus form a cross; and it also consists in so twisting said longitudinal wires as that the one shall pass between the points of each of the barbs on the other wire so as to lock them in position and prevent their untwisting.

Referring to our drawings, A and B are the longitudinal or main wires, on each of which are coiled two pointed wire barbs, having points marked respectively, A<sup>1</sup> and A<sup>2</sup>, and B<sup>1</sup> and B<sup>2</sup>. From these it will be seen that the first thing to do is to twist or coil the barbs on the longitudinal wires at regular distances apart, and in this coiling of barbs on longitudinal wires we admit there is nothing new. It is new, however, so to direct the points of these barbs as that those on one wire point in an opposite, or in an approximately opposite, direction to those on the other wire so as to form a cross, and to fix them in such a position as that the barbs come into juxtaposition with and butt up against those on the other wire; and it is also new to twist two main or longitudinal wires so barbed as aforesaid in such a manner as that they each pass between the points of the barbs on the other wire; thus, wire A passes between points B<sup>1</sup> and B<sup>2</sup> of the barbs on wire B, whilst wire B passes between points A<sup>1</sup> and A<sup>2</sup> of the barbs on wire A.

Having thus described the nature of our invention, and the manner of performing same, we would have it understood that we do not claim to be the inventors of barbed wire of either a single or double strand, or longitudinal, twisted, or otherwise, but what we believe to be new, and therefore claim as of our invention, is—

First—So fixing the barbs (in barbed wire consisting of two twisted separately barbed longitudinal wires) as that the points of those on one wire point in an opposite direction, or in an approximately opposite direction, to those on the other wire, so as to form a cross, substantially as described.

Second—So fixing the barbs described in the preceding claim as that when the two longitudinal wires are twisted together as shown in the drawing the barbs on one wire will come into juxtaposition with and butt up against those on the other wire.

Third—So twisting said longitudinal wires barbed as described in the preceding claims as that they each pass between the points of the barbs on the other wire, and so prevent their untwisting, substantially as described and as shown in our drawing.

Dated this fourth day of September, 1883.

COLIN MACKAY,  
HENRY WALDEN,  
HENRY NORTH,

(By their Attorney, EDWD. WATERS).

Witness—

W. S. BAYSTON,  
Patent Law Clerk, Melbourne.

This is the specification referred to in the annexed Letters of Registration granted to Colin Mackay, Henry Walden, and Henry North, this third day of December, A.D. 1883.

AUGUSTUS LOFTUS.

---

REPORT.

---

Sir,  
In reply to your B.C. minute of the 10th instant, enclosing application from Messrs. Mackay, Walden, and North, for Letters of Registration for an invention entitled "Improvements in Barbed Wire," we have the honor to report that we are of opinion that the prayer of such Petition might be complied with.

Sydney, 15 September, 1883.  
We have, &c.,

JAMES BARNET.  
WILLIAM C. BENNETT.

The Under Secretary of Justice.

---

[Drawings—one sheet.]

---

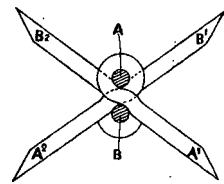
No. 1343.

[Assignment of all interest in "The Australian Combination Railway and Train Truck for Goods Cattle, or Sheep."]

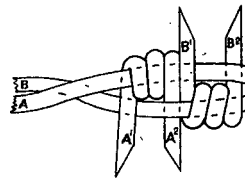
---

No. 1344.

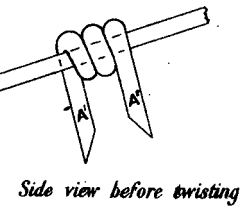
[Assignment of No. 652. See Letters of Registration for 1878, page 1.]



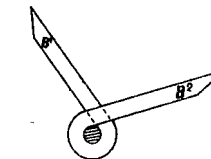
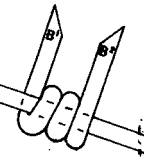
*End view of both barbs  
in position on wires*



*Side view when twisted*



*Side view before twisting*



*End view of single barb*

*This is the Sheet of Drawings referred to in the annexed  
Letters of Registration granted to John Mackay, Henry  
Walden, and Henry North, this third day of Dec<sup>r</sup> 1883.*

*Augustus Loftus.*



A.D. 1883, 21st December. No. 1345.

**MACHINE FOR ROLLING (WITH OR WITHOUT WIRE), CLOSING, AND FASTENING  
BOTTOMS IN ALL KIND OF HOLLOWWARE.**

LETTERS OF REGISTRATION to Charles Benjamin Taylor, for Improvements in a Machine for Rolling (with or without wire), Closing, and Fastening Bottoms in all kind of Hollowware made from Sheet Metals, either in tin, brass, copper, iron, or zinc.

[Registered on the 21st day of December, 1883, in pursuance of the Act 16 Vic. No. 24.]

BY HIS EXCELLENCY THE RIGHT HONORABLE SIR AUGUSTUS WILLIAM FREDERICK SPENCER LOFTUS (commonly called LORD AUGUSTUS LOFTUS), Knight Grand Cross of the Most Honorable Order of the Bath, a Member of Her Majesty's Most Honorable Privy Council, Governor and Commander-in-Chief of the Colony of New South Wales and its Dependencies.

TO ALL TO WHOM THESE PRESENTS SHALL COME, greeting :

WHEREAS CHARLES BENJAMIN TAYLOR, of Christchurch, New Zealand, merchant, hath by his Petition humbly represented to me that he is the assignee of Clement Kind, of Addington, near Christchurch aforesaid, who is the author or designer of a certain invention or improvement in manufactures, that is to say, of an invention entitled "Machine for Rolling (with or without wire), Closing, and Fastening Bottoms in all kind of Hollowware made from Sheet Metals, either tin, brass, copper, iron, or zinc," which is more particularly described in the specification and the sheet of drawings which are hereunto annexed; and that he, the said Petitioner, hath deposited with the Honorable the Treasurer of the said Colony of New South Wales the sum of Twenty Pounds sterling, for defraying the expense of granting these Letters of Registration, as required by the Act of Council, sixteenth Victoria, number twenty-four; and hath humbly prayed that I would be pleased to grant Letters of Registration, whereby the exclusive enjoyment and advantage of the said invention or improvement might be secured to him for a period of fourteen years: And I, being willing to give encouragement to all inventions and improvements in the arts or manufactures which may be for the public good, and having received a report favourable to the prayer of the said Petition from competent persons appointed by me to examine and consider the matters stated therein and to report thereon for my information, am pleased, with the advice of the Executive Council, and in exercise of the power and authority given to me by the said Act of Council, to grant, and do by these Letters of Registration grant unto the said Charles Benjamin Taylor, his executors, administrators, and assigns, the exclusive enjoyment and advantage of the said invention or improvement, for and during the term of fourteen years from the date hereof; to have, hold, and exercise unto the said Charles Benjamin Taylor, his executors, administrators, and assigns, the exclusive enjoyment and advantage thereof, for and during and unto the full end and term of fourteen years from the date of these presents next and immediately ensuing, and fully to be complete and ended: Provided always, that if the said Charles Benjamin Taylor shall not, within three days after the granting of these Letters of Registration, register the same in the proper office in the Supreme Court, at Sydney, in the said Colony of New South Wales, then these Letters of Registration, and all advantages whatsoever hereby granted, shall cease and become void.

In witness whereof, I have hereunto set my sign manual, and have caused the present Letters of Registration to be sealed with the seal of the said Colony of New South Wales, at Government House, Sydney, in New South Wales, this twenty-first day of December, in the year of our Lord one thousand eight hundred and eighty-three.

[L.S.]

AUGUSTUS LOFTUS.

*Machine for Rolling (with or without wire), Closing, and Fastening Hollowware &c.*

C.

## COMPLETE SPECIFICATION.

I, CLEMENT KIND, of Selwyn-street, Addington, near the city of Christchurch, in the provincial district of Canterbury, in the Colony of New Zealand, a tool-maker and die-sinker, do hereby declare the nature of the said invention for rolling (with or without wire), closing, and fastening bottoms in all kinds of hollowware made from sheet metals, either tin, brass, copper, iron, or zinc, to be as follows:—

THE invention claimed consists of top and bottom tools, with groove inserted at bottom of each, either half-round or oval, to give any sized bead or tube required.

The bodies of the articles to be operated on are first made into a cylinder of the required size for tools (either by soldering or grooving).

Should the bead or tube be required at one end only the bottom tool only will be used.

Should the bead or tube be required top and bottom of cylinder then the top and bottom tools or dies must be used; or should a bottom be required only in cylinder the bottom must be made into a disc and placed inside cylinder with edges placed outwards. The top tool or die only is then required, with a block inside to fit cylinder, and bead or tube rolled inwards over edge of bottom, thus fastening bottom and cylinder together.

Should the cylinder require a bead formed on top as well as bottoming then both tools or dies must be used, as shown in drawing.

Given under my hand and seal, at Christchurch, in the said Colony of New Zealand, this thirty first day of October, in the year of our Lord one thousand eight hundred and eighty-three.

CLEMENT KIND.

Signed by the said Clement Kind, in the presence of,—

C. T. NEWTON,  
Articled Law Clerk,  
Christchurch, New Zealand.

This is the specification marked C referred to in the annexed declaration of Charles Tazewell Newton, declared this first day of November, 1883.

Before me,  
LEONARD HARPER,  
Notary Public.

This is the specification referred to in the annexed Letters of Registration granted to Charles Benjamin Taylor, this twenty-first day of December, A.D. 1883.

AUGUSTUS LOFTUS.

## REPORT.

Sir,

Sydney, 29 November, 1883.

Referring to your B.C. memo. No. 83/13,636, of the 16th instant, forwarding a Petition for Letters of Registration for an invention entitled "Machine for rolling (with or without wire), closing, and fastening bottoms on all kinds of hollowware made from sheet metals, either tin, brass, iron, or zinc," on behalf of Mr. C. B. Taylor, as assignee of Clement Kind, of New Zealand, inventor, we have the honor to inform you that having examined the specification and plan accompanying the Petition, we are of opinion that Letters of Registration should be granted to the Petitioner for the invention referred to.

We have, &amp;c.,

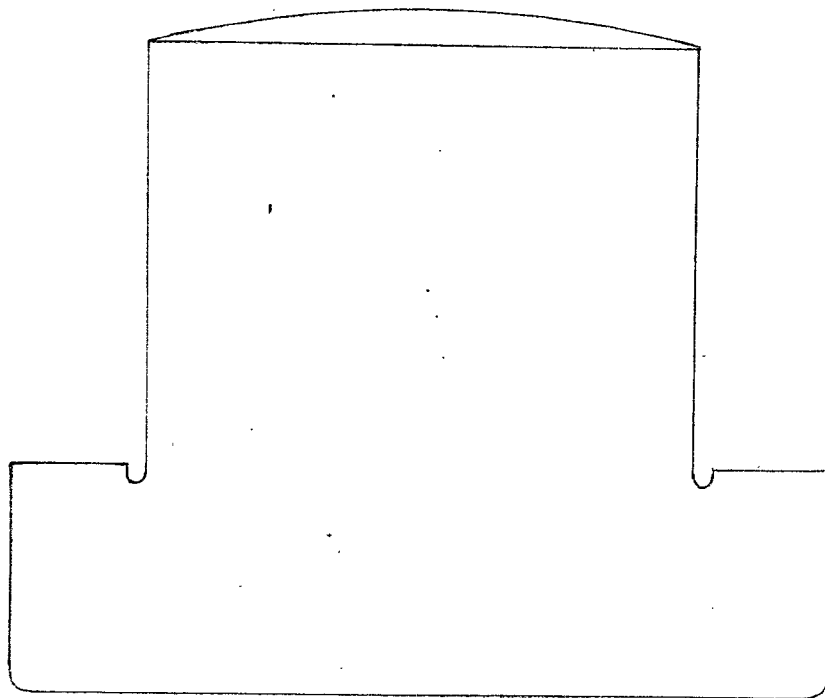
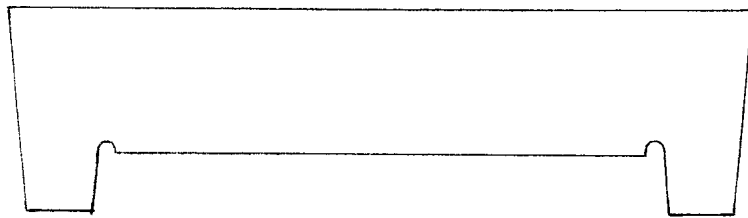
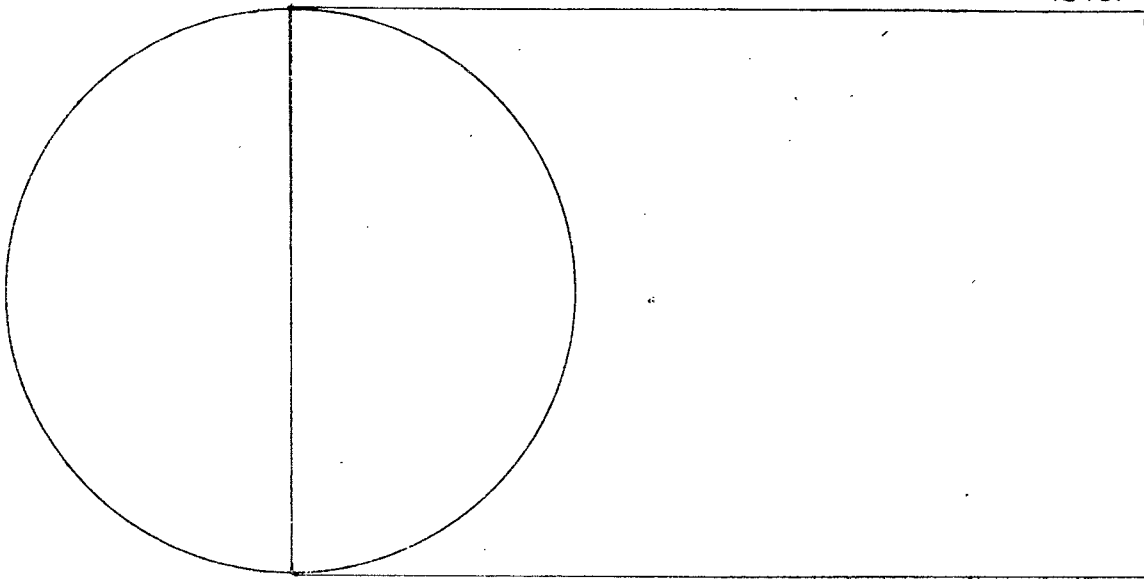
JOHN WHITTON.  
E. O. MORIARTY

The Under Secretary of Justice.

[Drawings—one sheet.]

"C"

1345.



(Signed) *Clement Kind.*

*Witness to the signature of Clement Kind*

*C.T. Newton,*

*Articled Law Clerk*

*Christchurch, New Zealand.*

*These are the Drawings marked "C" referred to in the annexed Declaration of Charles Tuzewell Newton, Declared this first day of November, 1883, Before me, Leonard Harper:*

*Notary Public.*

*This is the Sheet of Drawings referred to in the annexed Letters of Registration granted to Charles Benjamin Taylor, this twenty first day of December, A.D., 1883.*

*Augustus Loftus.*





A.D. 1883, 27th December. No. 1346.

IMPROVEMENTS IN THE CONSTRUCTION OF DYNAMO-ELECTRIC MACHINES.

LETTERS OF REGISTRATION to William Buller Fullerton Elphinstone (Baron Elphinstone) and Charles Wilson Vincent, for Improvements in the Construction of Dynamo-Electric Machines.

[Registered on the 28th day of December, 1883, in pursuance of the Act 16 Vic. No. 24.]

By HIS EXCELLENCY THE RIGHT HONORABLE SIR AUGUSTUS WILLIAM FREDERICK SPENCER LOFTUS (commonly called LORD AUGUSTUS LOFTUS), Knight Grand Cross of the Most Honorable Order of the Bath, a Member of Her Majesty's Most Honorable Privy Council, Governor and Commander-in-Chief of the Colony of New South Wales and its Dependencies.

TO ALL TO WHOM THESE PRESENTS SHALL COME, greeting :

WHEREAS WILLIAM BULLER FULLERTON ELPHINSTONE (BARON ELPHINSTONE), of Carberry Tower, Musselburgh, North Britain, and CHARLES WILSON VINCENT, of Holloway, in the county of Middlesex, England, electrician, have by their Petition humbly represented to me that they are the authors or designers of a certain invention or improvement in manufactures, that is to say, of an invention entitled "Improvements in the Construction of Dynamo-Electric Machines," which is more particularly described in the specification, marked A, and the nine sheets of drawings, marked B, C, D, E, F, G, H, I, and J, which are hereunto annexed; and that they the said Petitioners have deposited with the Honorable the Treasurer of the said Colony of New South Wales the sum of Twenty Pounds sterling, for defraying the expense of granting these Letters of Registration, as required by the Act of Council, sixteenth Victoria, number twenty-four; and have humbly prayed that I would be pleased to grant Letters of Registration, whereby the exclusive enjoyment and advantage of the said invention or improvement might be secured to them for a period of fourteen years: And I, being willing to give encouragement to all inventions and improvements in the arts or manufactures which may be for the public good, and having received a report favourable to the prayer of the said Petition, from competent persons appointed by me to examine and consider the matters stated therein and to report thereon for my information, am pleased, with the advice of the Executive Council, and in exercise of the power and authority given to me by the said Act of Council, to grant, and do by these Letters of Registration grant unto the said William Buller Fullerton Elphinstone (Baron Elphinstone) and Charles Wilson Vincent, their executors, administrators, and assigns, the exclusive enjoyment and advantage of the said invention or improvement for and during the term of fourteen years from the date hereof; to have, hold, and exercise unto the said William Buller Fullerton Elphinstone (Baron Elphinstone), and Charles Wilson Vincent, their executors, administrators, and assigns, the exclusive enjoyment and advantage thereof, for and during and unto the full end and term of fourteen years from the date of these presents next and immediately ensuing, and fully to be complete and ended: Provided always, that if the said William Buller Fullerton Elphinstone (Baron Elphinstone) and Charles Wilson Vincent shall not, within three days after the granting of these Letters of Registration, register the same in the proper office in the Supreme Court, at Sydney, in the said Colony of New South Wales, then these Letters of Registration, and all advantages whatsoever hereby granted, shall cease and become void.

In witness whereof, I have hereunto set my sign manual, and have caused the present Letters of Registration to be sealed with the seal of the said Colony of New South Wales, at Government House, Sydney, in New South Wales, this twenty-seventh day of December, in the year of our Lord one thousand eight hundred and eighty-three.

[L.S.]

AUGUSTUS LOFTUS.

*Improvements in the Construction of Dynamo-Electric Machines.*

A.

TO ALL TO WHOM THESE PRESENTS SHALL COME: We, WILLIAM BULLER FULLERTON ELPHINSTONE (BARON ELPHINSTONE), of Carberry Tower, Musselburgh, North Britain, and CHARLES WILSON VINCENT, of Holloway, in the county of Middlesex, England, electrician, send greeting :

WHEREAS we are desirous of obtaining Letters of Registration under the sign manual and seal of the Colony of New South Wales, for the exclusive enjoyment and advantage, for a period of fourteen years, of an invention for "Improvements in the Construction of Dynamo-Electric Machines," of which we are the first and true inventors: Now, know ye that the nature of the said invention, and the manner in which the same is to be performed, is particularly described and ascertained in and by the following statement, that is to say:—

The chief object of this invention is to obtain electric currents with a less expenditure of motive force than has heretofore been required in working dynamo-electric and magneto-electric machines. Our invention also includes certain improvements in the mode of constructing dynamo-electric and magneto-electric machines.

In attaining the first-named object we employ a novel arrangement of coils mounted on a diamagnetic rotary drum, which, as it is driven, causes the coils to cut the lines of magnetic force, and thereby induce in the coils more copious currents of electricity than have heretofore been obtained by a like expenditure of power, which currents may be used either as intensity or as quantity currents, according to the requirements of the work in hand.

We also provide for the supply from the armature coils to the coils of the field magnets of a determinate quantity of electricity for exciting those magnets, and the resistance to this exciting current we make adjustable to suit the work in hand.

In the accompanying drawings, fig. 1 shows our improved machine in end elevation; fig. 2 is a front view of the same; fig. 3 is a transverse vertical section taken in the line  $xx$  of figs. 2 and 4; and fig. 4 is a longitudinal vertical section taken through the axis of the machine.

AA are standards bolted to the bed-plate B and carrying a fixed shaft, C.

To this shaft are fitted radial plates of soft iron, DD, constituting stationary internal magnets. Mounted loosely upon the shaft C, and surrounding the magnets D, is an armature drum, E. The heads of this drum consist of open discs formed with elongated hubs or sleeves fitting on to journals on the shaft C. The heads are connected to the barrel of the drum (which is made of some diamagnetic material such as millboard) by screws inserted in its periphery, or in any other convenient manner.

Surrounding the drum are hanks of insulated wire  $e$  laid longitudinally thereon. The way of arranging these hanks and of bringing down the terminals of the hanks is clearly shown in figs. 4 and 5, which latter figure shows the commutator end of the armature drum.

The armature drum is situated between a pair of side frames, F F, which are bolted to the bed-plate B. The use of these side frames is to carry the magnets G G, which surround the armature drum and constitute the outside field magnets.

These magnets G are V shaped in cross-section, and are composed of plates of soft iron rebated at their connected edges and secured together by bolts. This mode of construction facilitates the winding on of the insulated wire.

The magnets G are set radially and concentrically around the armature drum, and are secured to the side frames by transverse brass or gun-metal bolts  $G^1$ , which extend from one side frame to the other.

H is the commutator keyed on a sleeve of the armature drum, and I is a band pulley keyed on the other sleeve of the drum. Through this pulley rotary motion is imparted to the armature drum for the purpose of setting the machine in action.

K is an annular frame carried by and capable of rotation upon the fixed shaft C. This frame carries the commutator brush-holders, and may be fixed in any required position by means of the screw clips  $k$ .

The magnets D (see fig. 3) are so coiled as to constitute them alternately north and south poles, as indicated by the letters N and S in fig. 3. Similarly the magnets G are so arranged as to present opposing poles to the magnets D, as is also indicated by the letters N S. Both the internal and external magnets are provided with broad pole-pieces for the purpose of presenting broad magnetic fields to the coils or hanks of the rotating armature, and the ends of the coils of these two sets of magnets are led to a grouping tablet, L, as will be hereafter more particularly described.

In the drawings figs. 3 and 5 show that the armature drum is provided with eighteen hanks of insulated wire, and these hanks we so proportion with respect to the opposite poles of each field magnet as to enable them each to reach from one pole to the next adjacent pole of the field magnets. The hanks are composed each of two wires, so as to produce two distinct currents, or the number of hanks may be doubled, each hank being formed of a single wire. Thus, the eighteen or thirty-six hanks will in either case present a total of seventy-two terminals, which are permanently connected in pairs, each pair with a bar of the commutator H, or each of the eighteen hanks may be composed of a single wire, in which case the hanks are so arranged as to form three layers, each layer containing six hanks. The construction of the commutator is best illustrated by the detached views, figs. 6 and 7, which represent it on an enlarged scale, fig. 6 being an end elevation partly in section, and fig. 7 a longitudinal vertical section of the commutator.

It consists of a brass tube,  $h$ , upon which is fitted a cylinder of vulcanite,  $h^1$ , grooved longitudinally to receive a series of brass bars,  $h^2$ —in this case thirty-six in number, two for each double coil on the armature. These bars are V shaped in cross-section, and they are severally formed with a bevelled recess at each end.

The brass tube  $h$  is provided at one end with a bevelled flange to receive one of the recessed ends of the bars  $h^2$ , but is insulated therefrom by means of a vulcanite cone,  $h^3$ . An annular plate,  $h^4$ , similarly bevelled to fit the opposite ends of the bars  $h^2$ , and insulated therefrom, is secured to the other end of the tube  $h$  by bolts  $h^5$ . By screwing up these bolts the bars  $h^2$  will be drawn down into the grooves in the vulcanite cylinder  $h^1$ , and securely held therein.

We

*Improvements in the Construction of Dynamo-Electric Machines.*

We have found, in working the above-described machine, that when the maximum amount of work which it is calculated to perform is put upon it in the external circuit, the greatest economy, in respect of the expenditure of power, is observable. This is due to the small percentage of internal resistance which exists, in comparison with the external resistance. But on reducing the amount of work in the external circuit the proportion of the total power employed in overcoming the internal resistance of the machine was increased, and this in the reverse proportion to the reduction of the efficient work performed.

This effect is due to the internal resistance of the machine being a constant quantity, although the efficient work outside is caused to vary.

With the object of securing economical working dynamo machines have hitherto been constructed specially for the work required to be performed, the prevalent belief being that to secure this result it was necessary to work them near to or up to their highest capacity.

In order, however, to render these machines, like motive-power engines, capable of working economically under varying circumstances, for example, to maintain indifferently lamps connected in series or single parallels, or one hundred or five hundred lamps in a series, in single groups or parallels, as circumstances may require, we divide up the field, and send separate and distinct currents through groups of coils or through each coil, as circumstances may require, in place of connecting all the coils of the field magnets together, as heretofore, whereby one unalterable course of the exciting current was provided, and by this means to modify the resistance so as to suit the work in hand.

It is for this purpose that we bring the terminals of each coil of the internal and external field magnets to the grouping tablet L, which is situated for convenience in front of one of the standards A of the machine. To this tablet also we connect the ends of the wires that serve to convey the exciting current to the field.

We will now explain in detail how the results which this part of our invention is intended to secure are obtained, reference being had to the diagram fig. 8, where the outer field magnets are marked with the letters *a, b, c, d, e, f*, and the inner field magnets *a\*, b\*, c\*, d\*, e\*, f\**.

The grouping tablet may be described as consisting of a slab of insulating material carrying on its face a number of pairs of brass plates corresponding to the number of magnets forming the fields.

These plates are arranged in two sets—the one set being coupled up with the external and the other set with the internal field magnets.

The connection of these plates with their respective magnets we have indicated by giving to them similar letters of reference, distinguishing by numbers which pole of each magnet is connected with its respective plate. Thus, the pole 1 of the magnet *a* will be connected with the plate *a*<sup>1</sup>, and the pole 2 of the same magnet will be connected with the plate *a*<sup>2</sup>. Similarly, the pole 1 of the magnet *a\** is connected with the plate *a\**<sup>1</sup>, and the pole 2 of the magnet *a\** is connected with the plate *a\**<sup>2</sup>, and so on throughout the two series.

These series of plates, all insulated the one from the other, are divided by a brass strip, *g*, and they are surrounded on three sides by an insulated brass strip *g*<sup>1</sup>. This strip is connected by a shunt wire with one of the brushes H<sup>1</sup>, and the insulated strip *g* is similarly connected with the other brush, H<sup>1</sup>. Thus, when the machine is set to work the induced exciting current intended for the field will be conducted by a shunt wire to the grouping tablet L, whence it may be delivered to the field magnet coils in the order best suited for the work in hand, and returned to the tablet, and thence through the second shunt wire to complete the derived circuit. The diagram fig. 8 shows a number of holes made in the insulating slab, between the pairs of plates and the strips *g* and *g*<sup>1</sup>, which lie parallel thereto.

These holes are intended to receive metal plugs to establish metallic contact where desired.

Supposing now it is desired to obtain a current of maximum intensity, we couple up the magnet coils as indicated in the diagram fig. 8, where the white spots indicate the inserted plugs—the black spots serving to show the vacant holes.

When the plates and strips are put into metallic communication as in fig. 8 the course of the current will be as follows:—

The current entering by the strip *g* will pass to the plate *a*<sup>2</sup>, thence through the coil of the magnet *a*, and back to the plate *a*<sup>1</sup>, from this plate it will pass to the plate *b*<sup>1</sup>, thence around the magnet *b*, back to the plate *b*<sup>2</sup>.

From this plate it will pass by the contact plug to the plate *c*<sup>2</sup> around the magnet *c*, back to the plate *c*<sup>1</sup>, and so on through the series of plates and magnet coils until the current reaches the last plate, *f*<sup>2</sup>, of the outside series, which plate is made V shaped to extend past the plate *a*<sup>2</sup>.

Here it meets an extension of the plate *a\**<sup>2</sup> of the inner series of electro-magnets, and being coupled to that plate by a metallic plug the current passes to that plate, and thence through the coil of the electro-magnet *a\**. From this magnet the current passes to the plate *a\**<sup>1</sup>, and thence, in consecutive order through the coils of all the internal magnets until it passes from the coil of the magnet *f\** to the plate *f\**<sup>2</sup>.

As this plate is connected by a metallic plug with the strip *g*<sup>1</sup> the current will pass to that strip, and thence through the wire which connects it with a brush, H<sup>1</sup>, thus completing the circuit.

This mode of coupling up permits of the exciting current passing in the ordinary manner through the field, and will ensure the full efficiency of the machine when the maximum resistance in the field magnets is required.

Supposing now it is desired to reduce the resistance in the field magnets to meet a varied condition of the work to be performed, we couple up our metallic plates and strips, as illustrated at diagram fig. 9, where it will be seen that each pair of plates is in direct communication with the strips *g* and *g*<sup>1</sup>; thus, the current entering at *g* will pass simultaneously by the plates *b*<sup>1</sup> *c*<sup>2</sup> *d*<sup>1</sup> *e*<sup>2</sup> *f*<sup>1</sup> *a*<sup>2</sup> to their respective magnets, thence back to the plates *a*<sup>1</sup> *b*<sup>2</sup> *c*<sup>1</sup> *d*<sup>2</sup> *e*<sup>1</sup> *f*<sup>2</sup> to the strip *g*<sup>1</sup>, and so to the brush by which the circuit is completed.

Similarly the current from the strip *g* will be divided up among the plates *a\**<sup>1</sup> to *f\**<sup>2</sup> of the inner field magnets.

By

*Improvements in the Construction of Dynamo-Electric Machines.*

By thus coupling up the terminals on the grouping tablet *L* the resistance of the field magnets will be reduced to a minimum, and the motive force employed for driving the machine will be proportionately efficiently employed in producing currents for external work.

A further and most important advantage consequent on this mode of reducing the resistance is that when half or three-fourths of the number of lamps in a circuit are thrown out of use the ratio of the internal resistance of the machine to the work performed will remain the same, and consequently the motive power required to drive the machine may be reduced as the external work of the machine is reduced.

The diagram fig. 10 illustrates a mode of coupling whereby the exciting current is sent through the group of external magnets in series and through the group of internal magnets in series; thus the resistance is very greatly increased as compared with diagram 9, and is reduced to one-fourth as compared with diagram 8.

Comparing diagram 10 with diagram 8, it will be seen that this change in the working of the machine is effected by simply withdrawing the metallic plug which couples the plate  $f^2$  with the plate  $a^{*2}$ , and connecting these two plates by metallic plugs, the one  $a^{*2}$  with the strip  $g$ , and the other  $f^2$  with the strip  $g^1$ .

The other brushes,  $H^1$  and  $H^2$ , which are to be used for the external circuits, may conveniently be connected with a second grouping tablet, *M*, figs. 1 and 8, which, being provided with metallic plugs, will facilitate the coupling up of the brush wires for intensity or quantity to suit the work in hand.

In explaining this part of our invention we have referred to a machine in which the exciting current is obtained from a shunt in the well-known manner; we may, however, use one of the main circuits as the exciting current, or we may obtain it from a special series of coils or hanks on the armature, collecting the same on an independent commutator, or we may obtain the current from a source distinct from the machine to be excited, but the current, however derived, will be conducted to the grouping tablet *L* or its equivalent, and distributed through the magnetic field in the manner above explained to suit the work in hand.

From the foregoing it will be understood that the application of this part of our invention is not limited to the form of dynamo-electric machine shown in the drawings, but may be applied wherever the field contains two or more magnets.

The form of the coils or hanks used on the armature drum is that of a broad link, composed, as above stated, of one or more wires; and we propose, as another feature of our invention, instead of winding these hanks upon the armature *in situ*, to wind each one upon a mould or "former," making it of suitable length to fit the armature drum.

Fig. 11 shows a coil or hank of the form which we employ; fig. 12 is a side view, and fig. 13 an edge view of the "former" on which the hank is wound.

It consists of a base board, *a*, which is to be mounted on a mandrel, and of a moulding block, *b*, which is made fast by screws and fly nuts *c c* to the base boards.

This moulding block is composed of three loose pieces (see fig. 12), the middle piece lying diagonally and being slightly chamfered inwards at its contact edges to facilitate by its removal the withdrawal of the hank from the moulding block when that block is detached from the base board.

The wire to be formed into the coil or hank is first coated with cotton-yarn in the usual way; it is then passed through a bath of insulating material, such as asphalt dissolved in liquid hydro-carbon or any approved insulating compound, and while still wet from the bath the wire is slowly coiled upon the "former," short lengths of tape having been first placed transversely around the "former" to receive the wire. When the requisite length of wire has been coiled into the hank the hank is bound by the tapes to keep the coils together, and the "former" is removed from the mandrel and placed in a drying chamber to evaporate the solvent therefrom.

When the insulating material has set or hardened the hank is removed from the "former," and it then presents the appearance of fig. 11. In fitting it to the armature drum it will, however, be necessary to bend up the ends of the hank in order that they may overlie each other, and may be securely held on to the drum by suitable metal bands or clips.

To facilitate this bending of the hanks, a current of electricity may be passed through each hank in order to heat and thereby soften it, and, while in this soft state, the hanks may be moulded on the drum by pressure to the form required.

The hanks are laid upon the armature drum in such a way as to cover the whole periphery of the drum, the sides of the hanks being kept at a uniform level, while the ends, by overlapping, form irregular ridges. These ridges are, however, as will be seen by reference to figs. 2 and 4, external of the plane occupied by the field magnets *G*.

A binding cord is laid around the covered drum for a breadth somewhat exceeding the length of the field magnets, in order to secure the hanks in position; and, as a further security, cap rings *e* are placed over the ends of the hanks and made fast by screws to the armature drum-heads.

By providing the armature drum with two layers of hanks arranged as described, and by connecting their ends to the commutator bars in the manner shown and explained by the consecutive numbers in fig. 5, we obtain the advantage of causing two currents of the same name running in opposite directions to meet at each collecting brush, in the same manner as when we couple the ends of the double wire hanks. By connecting the terminals of the eighteen hanks of single wires disposed in three layers as above described, so that the end of one hank is on the same commutator bar with the beginning of the hank next but one following, the meeting under the collecting brush of two currents of the same name running in opposite directions will also take place. We have described the machine as fitted with a commutator and provided with six collecting brushes. It is found desirable, however, for some purposes, to connect these brushes together in two groups.

We now propose, instead of connecting the brushes together, to use but one pair of brushes, and to connect the bars, strips, or plates of the commutator in groups of three by means of removable metal grouping pieces insulated the one from the other.

Fig. 14 is an end view of the commutator with the grouping plates applied thereto, fig. 15 a side elevation, and fig. 16 a partial sectional elevation of the same.

In

*Improvements in the Construction of Dynamo-Electric Machines.*

In these figures  $h^2$  are the bars of the commutator H, coupled up, as already explained, with the hanks of the armature. The exposed ends of these bars have sockets formed in them to receive contact pins projecting from the inner face of a series of grouping plates,  $h^6$ . These plates consist of thin pieces of sheet brass fitted upon the armature sleeve, but insulated therefrom and from each other. They are packed closely together, and are set in front of the exposed end of the commutator.

To each of these plates,  $h^6$ , three contact pins are fitted at equal distances from each other, and at such a length of radius as to reach the sockets in the exposed ends of the commutator bars.

The length of these contact pins will vary for each plate, the pins of the outermost plate having to reach over the grouping plates, which lie between it and the commutator.

It will now be understood that when these grouping plates are brought up into position as shown in the drawing they will connect the bars  $h^2$  in groups of three, thus making virtually a series of twelve terminal plates for the armature, arranged as above described.

By this means, not only is the friction on the commutator reduced, but the "sparking" due to extra currents is considerably diminished, as is also loss of current from frequent making and breaking contact.

This construction of current grouper, it will be obvious, is applicable to other forms of commutator than that above described.

Having now explained the nature of our invention, we wish it to be understood that we claim:—

First—In dynamo-electric machines in which the field magnets are set around and concentrated with a diamagnetic drum arranging the hanks of such drum so that they shall overlie or underlie the one the other on its periphery in the manner described with reference to the drawings, whereby access to the interior of the drum for the adjustment or removal of the internal field magnet is facilitated.

Second—The construction of rotating commutator, as described with reference to figs. 6 and 7 of the drawings, consisting of a series of parallel bars set radially around an insulating cylinder, and held in place by a flange and cap-plate bearing on their ends.

Third—The mode of connecting the commutator with the terminals of the armature hanks, as explained with reference to fig. 5, whereby two currents running in opposite directions are caused to meet at each collecting brush.

Fourth—In a dynamo-electric machine a field or fields composed of separate magnet or magnets wound with distinct wires and independent of the main circuit or circuits, such magnets providing for the exciting current being passed around them singly or in groups directly from a common source without affecting the outside circuits, for the purpose above set forth.

Fifth—In electrical connection with the source of the exciting current for the field magnets of a dynamo-electric machine, and independent of the main circuit or circuits, a grouping tablet or its equivalent, in which the coils of the several field magnets have their terminals, such terminals being so arranged as to permit of their being connected separately with the source of supply or coupled up in series or groups for the purpose of adjusting the resistance to the exciting current to suit the work in hand, as described with reference to figs. 2, 8, 9, and 10.

Sixth—The manufacture of armature hanks of dynamo-electric machines by winding them upon a rotating "former," and moulding the same by heat and pressure, in the manner and for the purpose above set forth.

Seventh—The means above described with reference to figs. 14, 15, and 16, for grouping the currents derived from armature coils, consisting of removable grouping pieces fitted to one end of the commutator, and serving to minimize the "sparking" and the friction put upon the commutator by the brushes or rubbers.

In witness whereof, we, the said William Buller Fullerton Elphinstone (Baron Elphinstone) and Charles Wilson Vincent, have hereunto set our hands and seals, the seventh day of July, one thousand eight hundred and eighty-three.

ELPHINSTONE.  
CHAS. W. VINCENT.

This is the specification marked A referred to in the annexed Letters of Registration granted to William Buller Fullerton Elphinstone (Baron Elphinstone) and Charles Wilson Vincent, the twenty-seventh day of December, A.D. 1883.

AUGUSTUS LOFTUS.

### REPORT.

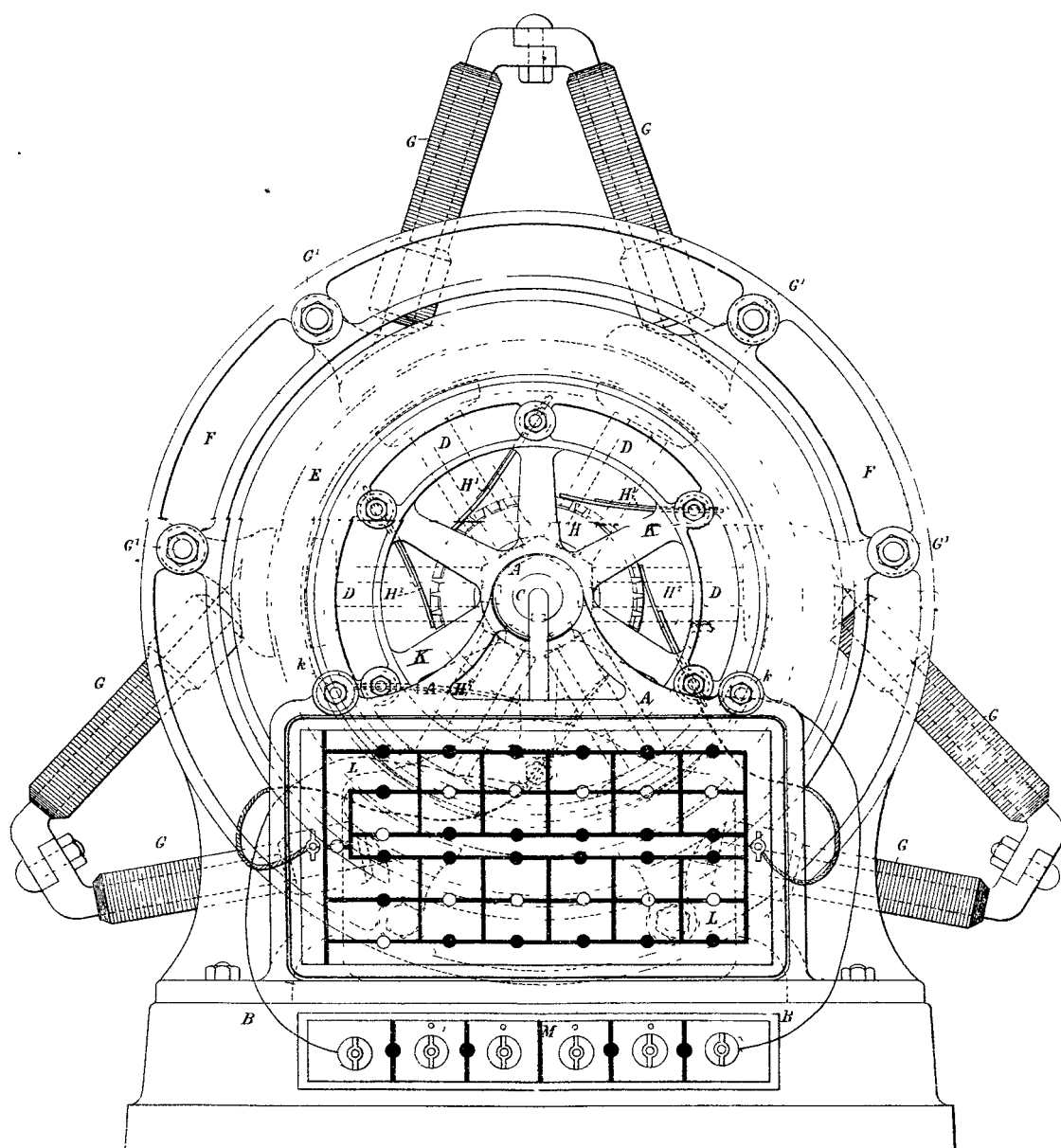
Sir,

We do ourselves the honor to report, in reply to your B.C. of the 25th ultimo, No. 11,873, transmitting the Petition of William Buller Fullerton Elphinstone (Baron Elphinstone) and Charles Wilson Vincent, for the registration of "Improvements in the construction of Dynamo-Electric Machines," that we are of opinion the prayer of the Petitioners may be granted, in terms of their specification, drawings, and claim.

Sydney, 9 October, 1883.  
We have, &c.,  
E. C. CRACKNELL.  
GOTHER K. MANN.

The Under Secretary of Justice.

FIG. I.

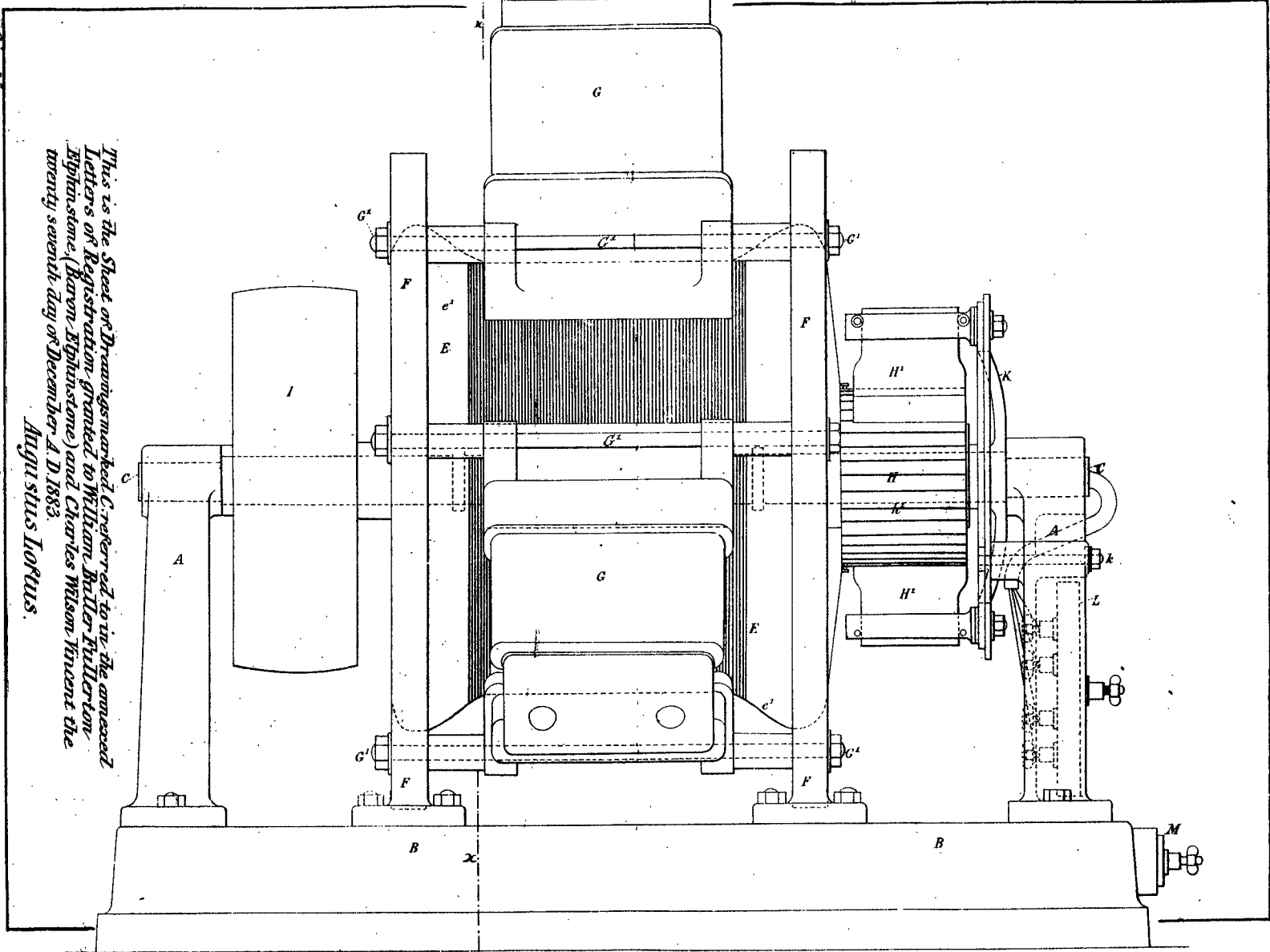


*This is the Sheet of Drawings marked B referred to in the annexed Letters of Registration granted to William Buller Fullerton Elphinstone (Baron Elphinstone) and Charles Wilson Vincent the twenty seventh day of December A. D. 1883.*

*Augustus Loftus.*

*Sig. 35.*

FIG. 2.



*This is the Sheet of Drawings marked C referred to in the annexed  
 Letters of Requestation granted to William Butler Hillorton  
 Ephraimstone (Baron Ephraimstone) and Charles Wilson Incent the  
 twenty seventh day of December A. D. 1883.*

*Angustus Iohannis.*

PHOTO-LITHOGRAPHED AT THE GOVT. PRINTING OFFICE,  
 STONE, NEW SOUTH WALES.

529.36

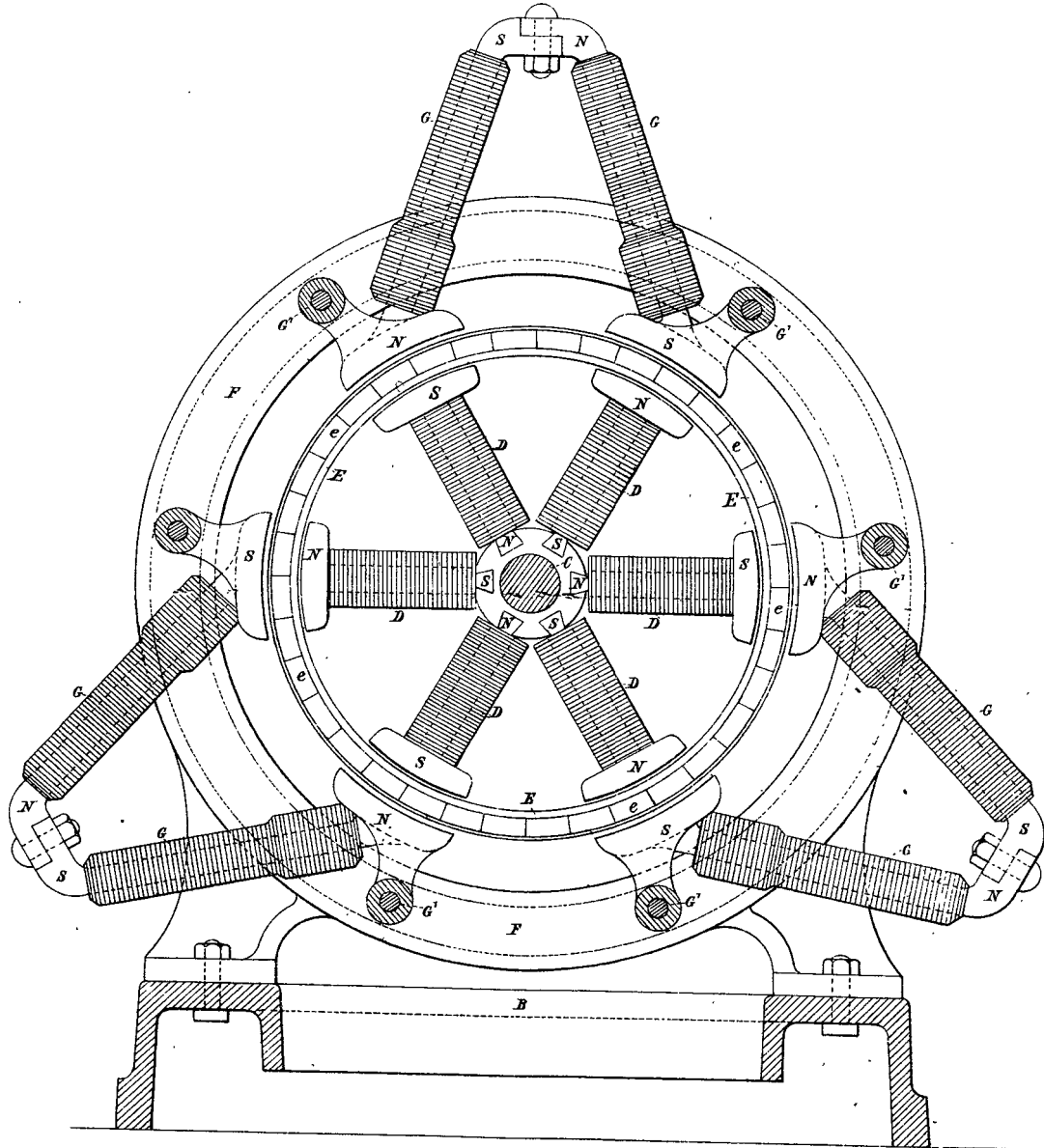
C

1346

D.

1346

FIG. 3.



*This is the Sheet of Drawings marked D referred to in the annexed  
Letters of Registration granted to William Butler Fullerton  
Elphinstone, (Baron Elphinstone) and Charles Wilson Vincent,  
the twenty seventh day of December A. D. 1883.  
Augustus Loftus.*

Fig 35.

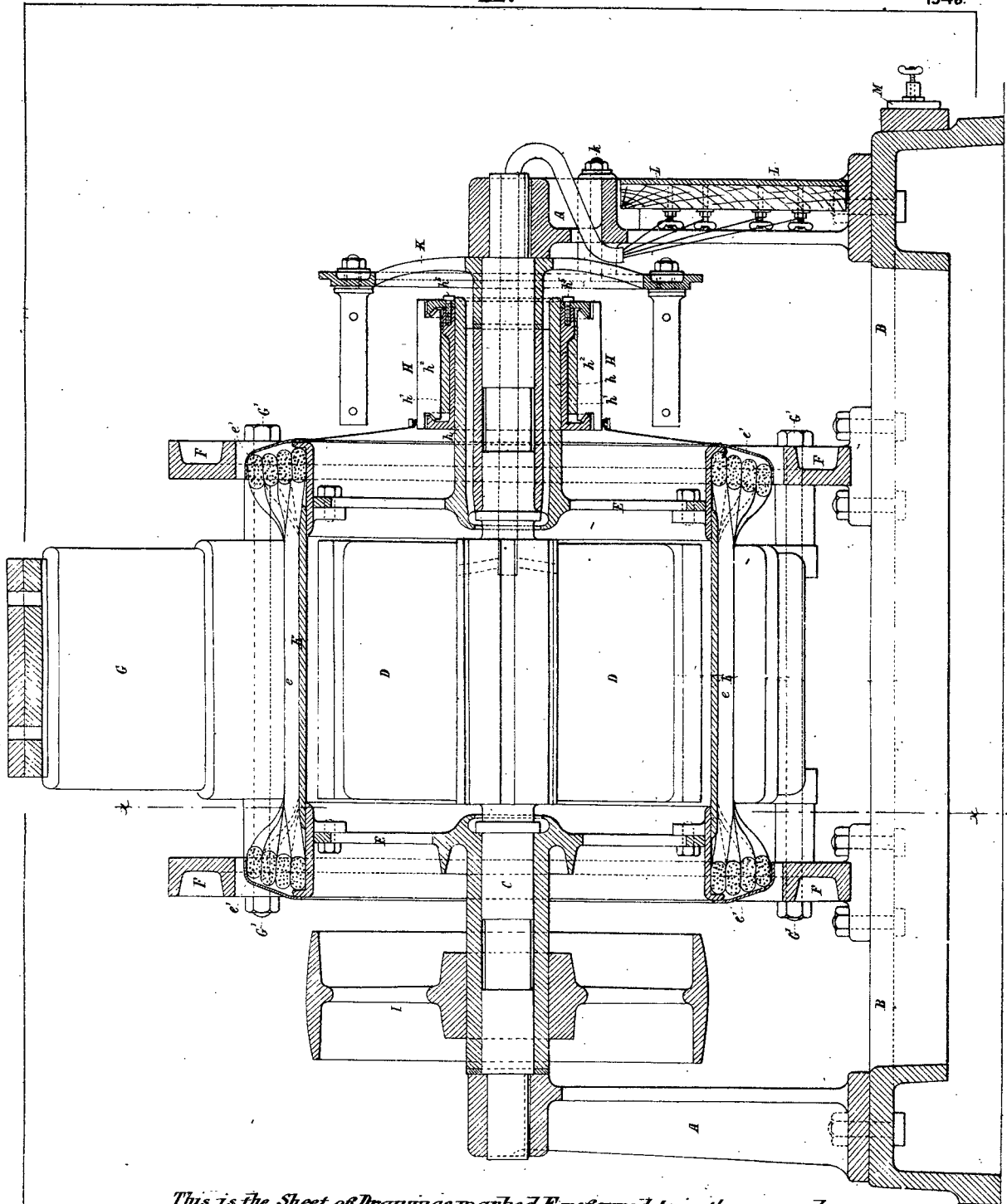
PHOTO-LITHOGRAPHED AT THE GOVT. PRINTING OFFICE,  
SYDNEY, NEW SOUTH WALES



E.

1346.

FIG. 4.



*This is the Sheet of Drawings marked E. referred to in the annexed  
Letters of Registration granted to William Butler Fullerton Elphinstone,  
(Baron Elphinstone) and Charles Wilson Vincent the twenty seventh day  
of December A.D. 1883.*

*Augustus Loftus.*

FIG. 5.

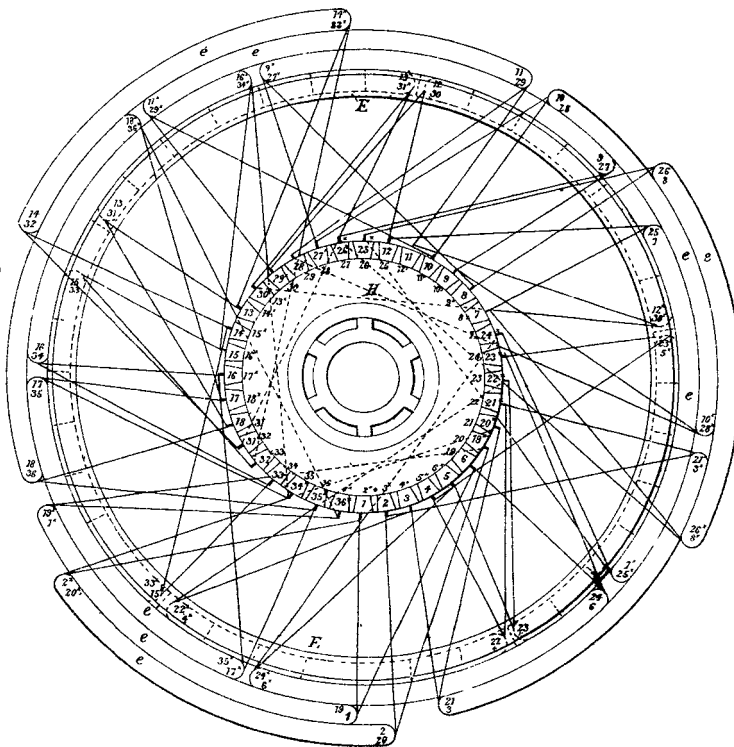


FIG. 6.

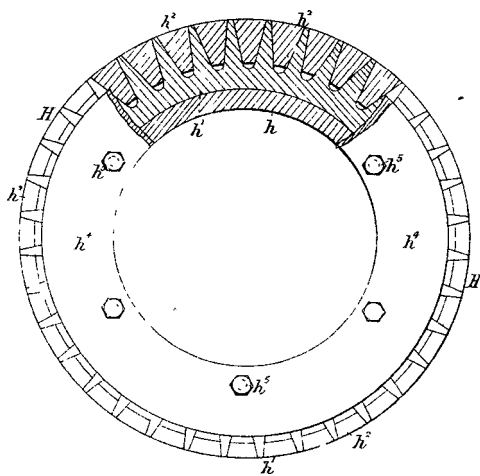
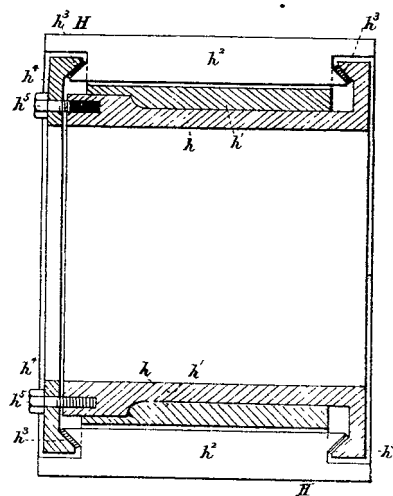


FIG. 7.

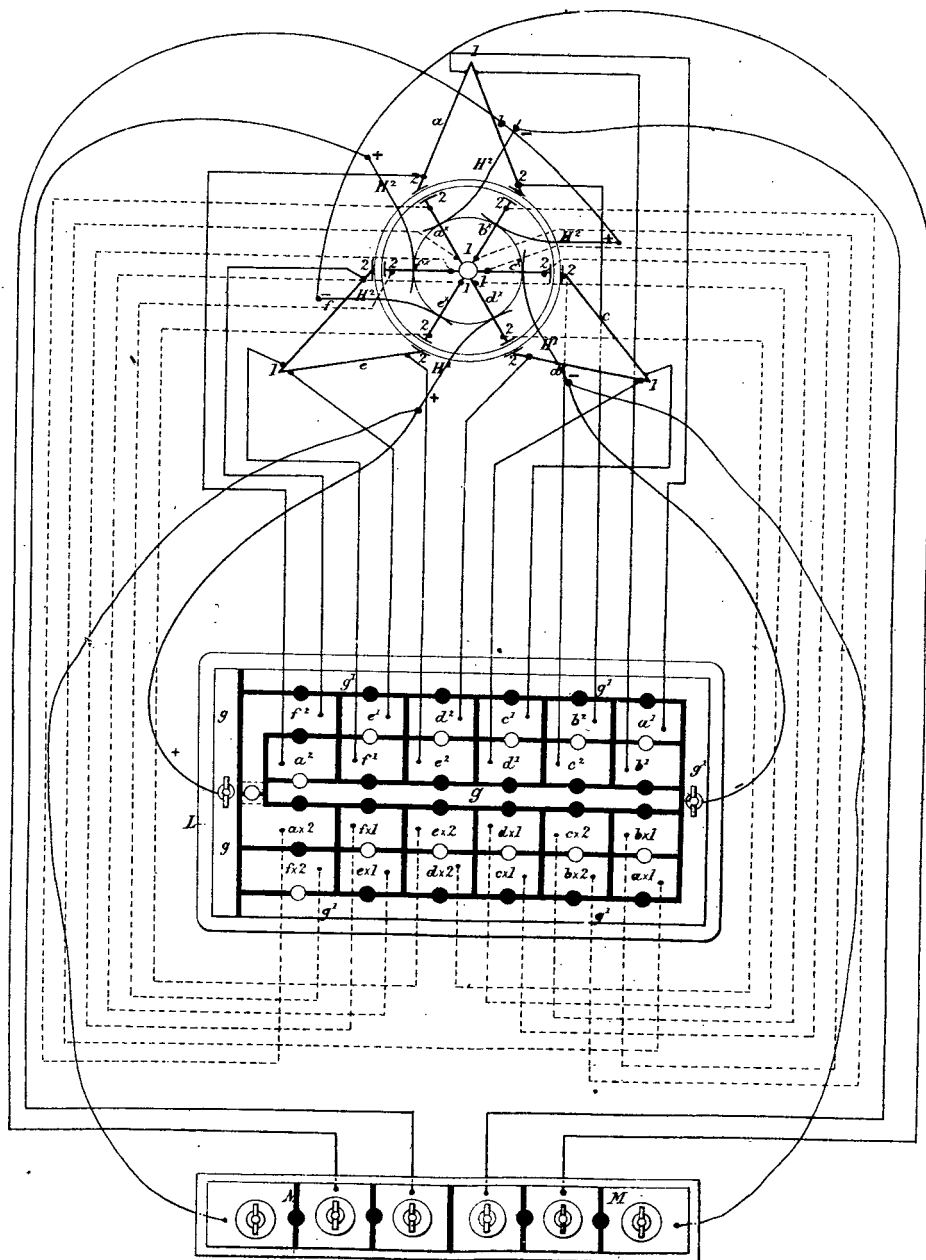


*Sig. 35.*

*This is the Sheet of Drawings marked *F* referred to in the annexed Letters of Registration granted to William Buller Fullerton Elphinstone, (Baron Elphinstone) and Charles Wilson Vincent, the twenty seventh day of December A.D. 1883.*

*Augustus Loftus.*

FIG. 8.



*This is the Sheet of Drawings marked G referred to in the annexed Letters of Registration granted to William Buller Fullerton Elphinstone, (Baron Elphinstone) and Charles Wilson Vincent, the twenty seventh day of December A. D. 1883.*

*Augustus Loftus.*

*Sig. 35*

FIG. 9.

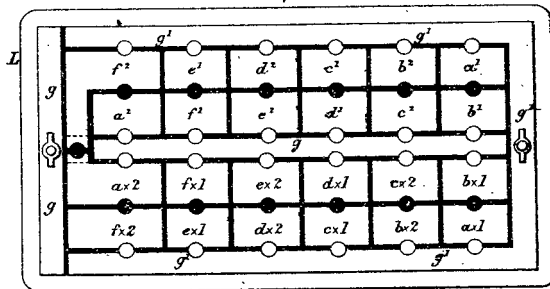
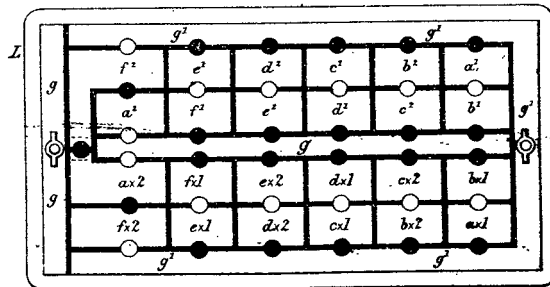


FIG. 10.



*This is the Sheet of Drawing marked H, referred to in the annexed Letters of Registration, granted to William Buller Fullerton Elphinstone, (Baron Elphinstone) and Charles Wilson Vincent, the twenty seventh day of December A. D. 1883.*

*Augustus Loftus.*

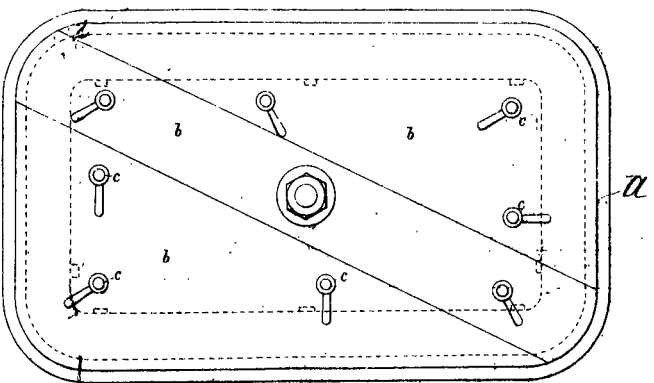


FIG. 12.

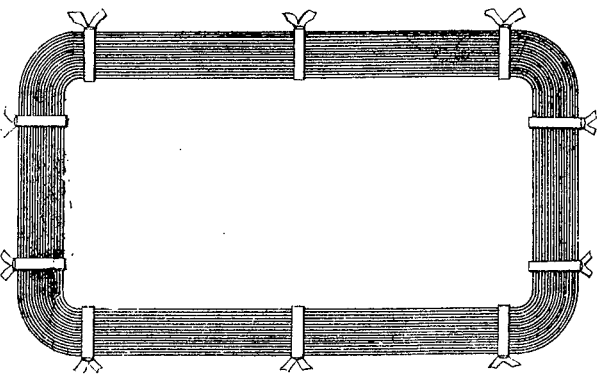


FIG. 11.

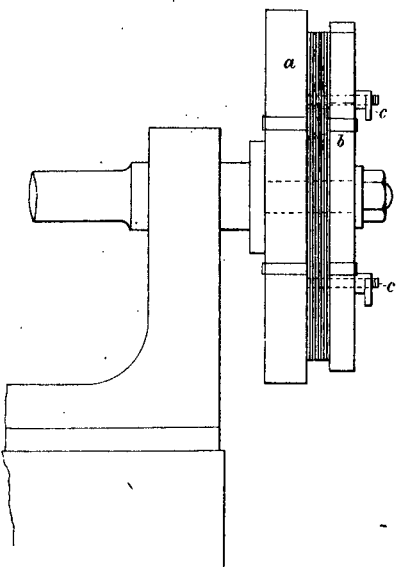
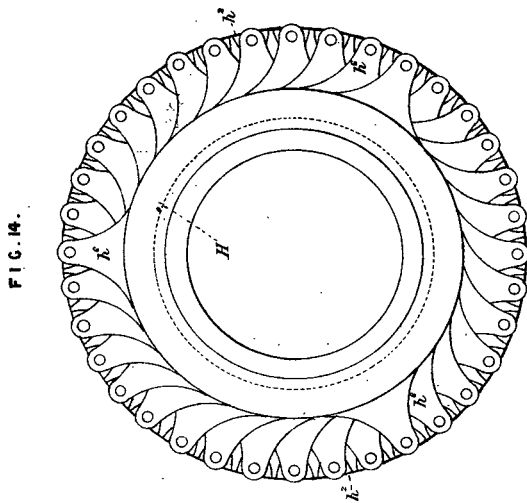
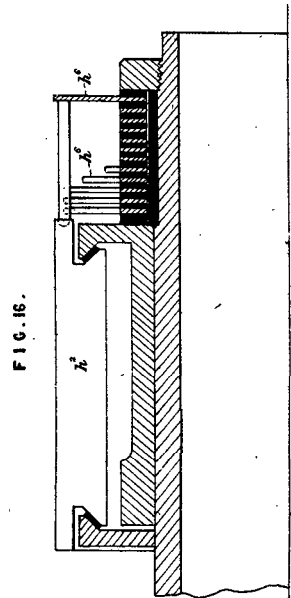
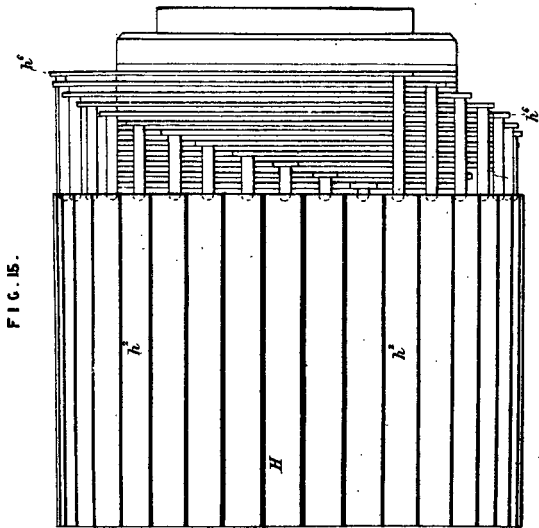


FIG. 13.

*This is the sheet of Drawings marked I referred to in the annexed Letters of Registration granted to William Butler Pittloring Diphonstone, Baron Diphonstone and Charles Wilson Incent, the twenty seventh day of December A.D. 1883.*

*Augustus Loftus*



*This is the Sheet of Drawings marked J. referred to in the annexed Letters of Registration granted to William Baller Fullerton Elphinstone, (Baron Elphinstone) and Charles Wilson Vincent the twenty seventh day of December A. D. 1883.*

*Augustus Loftus.*



A.D. 1883, 27th December. No. 1347.

AN IMPROVED PORTABLE GAS MACHINE.

LETTERS OF REGISTRATION to David Murray and Arthur Wellesley Parkinson for an Improved Portable Gas Machine.

[Registered on the 28th day of December, 1883, in pursuance of the Act 16 Vic. No. 24.]

BY HIS EXCELLENCY THE RIGHT HONORABLE SIR AUGUSTUS WILLIAM FREDERICK SPENCER LOFTUS (commonly called LORD AUGUSTUS LOFTUS), Knight Grand Cross of the Most Honorable Order of the Bath, a Member of Her Majesty's Most Honorable Privy Council, Governor and Commander-in-Chief of the Colony of New South Wales and its Dependencies.

TO ALL TO WHOM THESE PRESENTS SHALL COME, greeting :

WHEREAS DAVID MURRAY, merchant, and ARTHUR WELLESLEY PARKINSON, engineer, both of Sydney, in the Colony of New South Wales, have by their Petition humbly represented to me that they are the authors or designers of a certain invention or improvement in manufactures, that is to say, of an invention entitled "An Improved Portable Gas Machine," which is more particularly described in the specification and the sheet of drawings which are hereunto annexed ; and that they, the said Petitioners, have deposited with the Honorable the Treasurer of the said Colony of New South Wales the sum of Twenty Pounds sterling, for defraying the expense of granting these Letters of Registration, as required by the Act of Council, sixteenth Victoria, number twenty-four ; and have humbly prayed that I would be pleased to grant Letters of Registration, whereby the exclusive enjoyment and advantage of the said invention or improvement might be secured to them for a period of fourteen years : And I, being willing to give encouragement to all inventions and improvements in the arts or manufactures which may be for the public good, and having received a report favourable to the prayer of the said Petition from competent persons appointed by me to examine and consider the matters stated therein and to report thereon for my information, am pleased, with the advice of the Executive Council, and in exercise of the power and authority given to me by the said Act of Council, to grant, and do by these Letters of Registration grant unto the said David Murray and Arthur Wellesley Parkinson, their executors, administrators, and assigns, the exclusive enjoyment and advantage of the said invention or improvement for and during the term of fourteen years from the date hereof ; to have, hold, and exercise unto the said David Murray and Arthur Wellesley Parkinson, their executors, administrators, and assigns, the exclusive enjoyment and advantage thereof, for and during and unto the full end and term of fourteen years from the date of these presents next and immediately ensuing, and fully to be complete and ended : Provided always, that if the said David Murray and Arthur Wellesley Parkinson shall not, within three days after the granting of these Letters of Registration, register the same in the proper office of the Supreme Court, at Sydney, in the said Colony of New South Wales, then these Letters of Registration and all advantages whatsoever hereby granted, shall cease and become void.

In witness whereof, I have hereunto set my sign manual, and have caused the present Letters of Registration to be sealed with the seal of the said Colony of New South Wales, at Government House, Sydney, in New South Wales, this twenty-seventh day of December, in the year of our Lord one thousand eight hundred and eighty-three.

[L.S.]

AUGUSTUS LOFTUS.

*Improved Portable Gas Machine.*

SPECIFICATION of DAVID MURRAY, merchant, and ARTHUR WELLESLEY PARKINSON, engineer, both of Sydney, in the Colony of New South Wales, for an invention entitled "An Improved Portable Gas Machine."

THIS invention consists of a box, figures 1, 2, 3, 4, made of cast-iron or other material, and properly fitted with a cover, figures 1, 3, 4, secured to the box with bolts or other suitable fastenings; the box is made with internal divisions, as shown on drawing, figure 2, and numbered 1, 2, 3, 4.

The action is as follows:—Before the cover is fastened on the divisions are filled lightly with asbestos, fibre, cotton, wadding, or other porous material, K, and the cover is then closed up and does not again require to be removed; the reservoir or cistern A, figures 1 and 2, is then fixed on its place and filled with the hydrocarbonaceous liquid through a screw cap, B, figure 1, on top of the cistern; the box can then be charged by opening the valve E, communicating from cistern to the divisions in the interior of the box, and thus saturating the porous material. A small tap or valve is placed on the side of the box to show when sufficient liquid has been allowed to pass into it, F, figures 2 and 3.

The shape of this box can be made to suit requirements, and can be designed to suit or work in any position.

The gas is made by using an air-ometer, and forcing air from said omer through the inlet tap or valve, C, figures 1, 2, and 4, which has to pass round the divisions, as shown by the arrows, thus passing through all the porous material in the box before reaching the outlet tap or valve H, figures 1, 2, and 4, from which it may be burned with ordinary burners as hydrocarbon gas.

We claim:—

- 1st. The box; such box being fitted with internal divisions, causing the air to pass through a great length of porous material, ensuring its thorough carbonization, where a small box is used.
- 2nd. The application to this apparatus of an air-ometer for regulating the pressure to any number of lights, which does away with all pumps, fans, or other intricate machinery, thus simplifying the apparatus.
- 3rd. Its great portability and inexpensiveness, combined with its general simplicity and non-liability to get out of repair.

In witness whereof, we, David Murray and Arthur Wellesley Parkinson, have to this specification set our hands and seals, this eighth day of September, 1883.

D. MURRAY.

A. W. PARKINSON.

This is the specification referred to in the annexed Letters of Registration granted to David Murray and Arthur Wellesley Parkinson, the twenty-seventh day of December, A.D. 1883.

AUGUSTUS LOFTUS.

---

REPORT.

Sir,

The application of Messrs. Murray and Parkinson for Letters of Registration for "An Improved Portable Gas Machine," having been referred to us, we have examined the plans and specification accompanying the same, and have now the honor to report that we see no objection to the issue of Letters of Registration, as prayed for.

Sydney, 24 September, 1883.

We have, &c.,

JAMES BARNET.

EDMUND FOSBERY.

The Under Secretary of Justice.

---

Drawings—one sheet.

No. 1348.

[Assignment of No. 1345.]



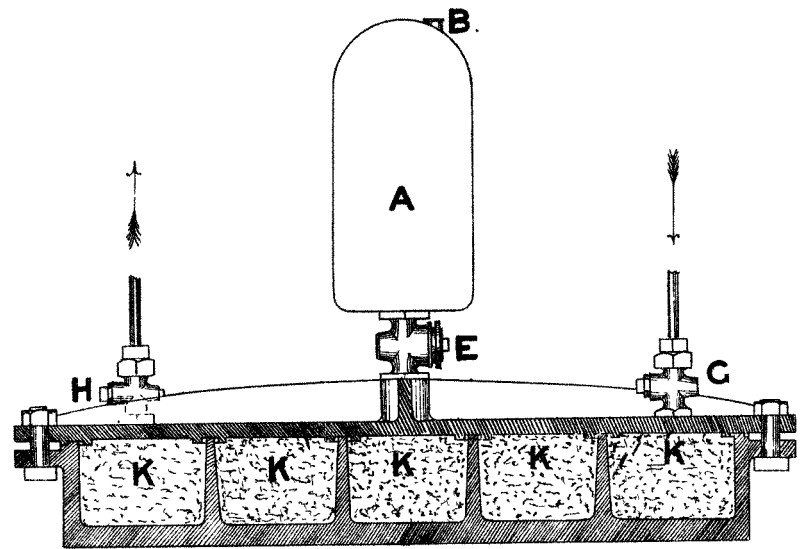


FIG. 1

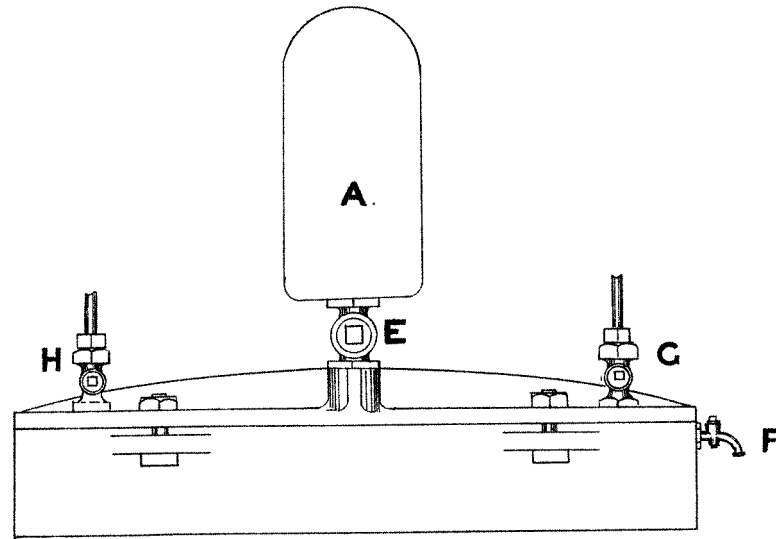


FIG. 3

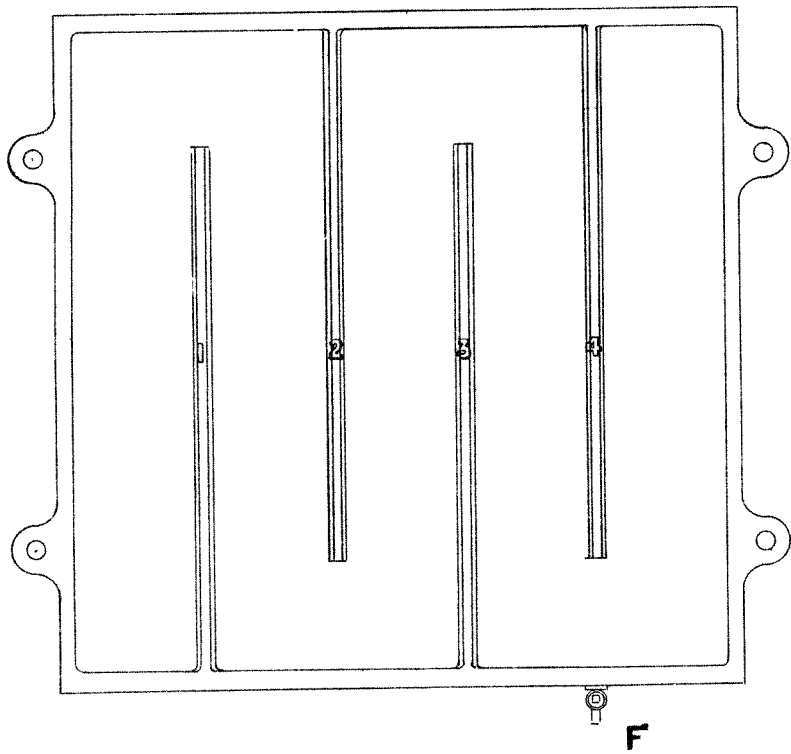


FIG. 2

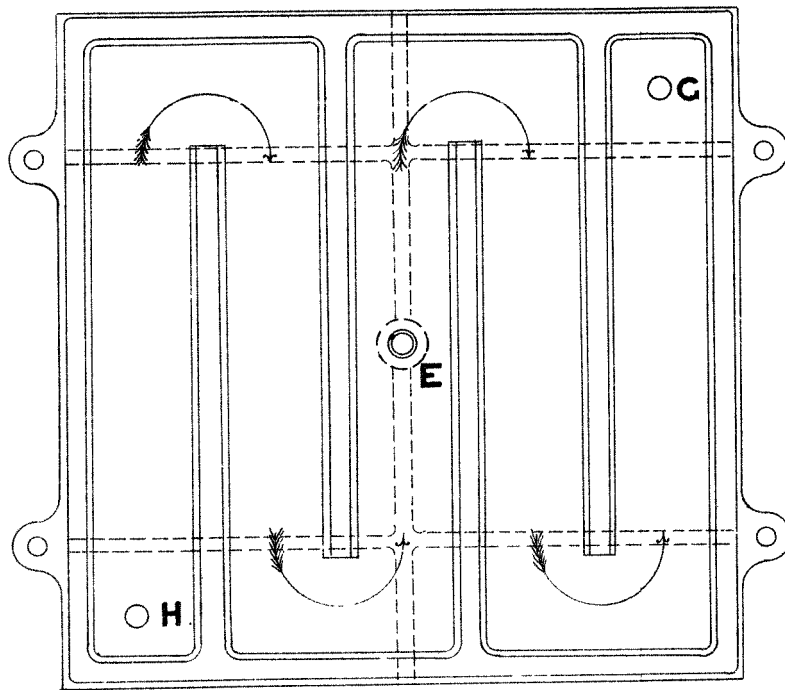


FIG. 4.

*This is the Sheet of Drawings referred to in the annexed  
Letters of Registration, granted to David Murray and  
Arthur Wellesley Parkinson, the twenty seventh day of  
December A. D. 1883.*

*Augustus Loftus.*

*D. Murray.  
A. W. Parkinson.*