

1887-8.

NEW SOUTH WALES.

VOTES

AND

PROCEEDINGS

OF THE

LEGISLATIVE ASSEMBLY

DURING THE SESSION

OF

1887-8,

WITH THE VARIOUS DOCUMENTS CONNECTED THEREWITH.

IN TEN VOLUMES.
VOL. X.

SYDNEY :

CHARLES POTTER, GOVERNMENT PRINTER, PHILLIP-STREET.

1888.

121087

1887-8.

LEGISLATIVE ASSEMBLY.
NEW SOUTH WALES.

VOTES AND PROCEEDINGS.

SESSION 1887-8.

IN TEN VOLUMES.

TABLE OF CONTENTS.

VOL. X.

Title Page.

Table of Contents.

Index.

PATENTS—

Letters of Registrations of Inventions for 1884 1

1887-8.

LEGISLATIVE ASSEMBLY.
NEW SOUTH WALES.

INDEX

TO THE
VOTES AND PROCEEDINGS

AND
PAPERS LAID UPON THE TABLE

DURING THE SESSION

OF

1887-8.

Opened 20 September, 1887, prorogued 24 July, 1888.

REFERENCES TO THE VOTES AND PROCEEDINGS, VOL. I—13TH PARLIAMENT—SESSION, 1887-8.		PAPERS	
	VOL.	PAGE.	
A			
ABATTOIRS, GLEBE ISLAND :— Petition from Municipal District Council of Leichhardt for abolition of, presented, 16	8	669	
ABBOTT, JOSEPH, ESQ. :— Return of Writ for Newtown, certifying to return of, reported, sworn, 249.			
ABBOTT, MR. J. P., M.P. :— Motion made (<i>Mr. Abbott</i>) to remove name from Select Committee on "Mineral Conditional Purchase, Parish of Metz," 462. Name of Sir Henry Parkes substituted for, on Committee on "Teralba Coal-mining Reserve," 585.			
ABBOTT, MR. T. K., STIPENDIARY MAGISTRATE— Return showing number and nature of complaints against Stipendiary Magistrates, laid on Table (not printed), 378.			
ABORIGINES OF THE COLONY :— Motion made (<i>Mr. Dowel</i>) for Committee of the Whole for Address to Governor for £10,000 for supplying rations, clothing, and shelter to, and withdrawn, 129. Annual Report of Board for Protection of, for 1887, laid on Table, 475	4	687	
ABSENCE (See "LEAVE OF ABSENCE").			
ACCIDENT (See "RAILWAYS").			
ACCOMPLICES EVIDENCE AMENDING BILL :— Motion made (<i>Mr. Hassall</i>) for Committee of the Whole, 215; Order of the Day postponed, 253, 325, 508; discharged, 608.			
ACCOUNTS (See "FINANCE").			
ACQUISITION OF LAND (See "PUBLIC WORKS BILL").			
ADDISON, MR., STIPENDIARY MAGISTRATE :— Motion made (<i>Mr. O'Sullivan</i>) for a Select Committee to inquire into charges of misconduct alleged against, by a meeting of licensed cabmen and drivers, and debate adjourned, 130; Order of the Day postponed, 147; debate resumed and motion negatived, 234. Return of cases heard at Water Police Court by, on 17th November, 1887, laid on Table (not printed), 174. Petition from C. Prince, Chairman of meeting of licensed drivers, expressing dissatisfaction with, when adjudicating in cases in which they were concerned, and praying the appointment of a Select Committee, 185	2	625	
Return showing number and nature of complaints against Stipendiary Magistrates, laid on Table not printed, 378.			
ADDITIONAL SITTING DAYS (See also "ASSEMBLY") :— Friday made a sitting day, meet at 3 o'clock, and Government business to take precedence of general business after 7 o'clock, p.m., 103; rescinded, 325. Monday made a sitting day, meet at 3 o'clock, and Government business to take precedence, 585.			

REFERENCES TO THE VOTES AND PROCEEDINGS, VOL. I—13TH PARLIAMENT—SESSION, 1887-8.	PAPERS.	
A	VOL.	PAGE.
ADDITIONAL STANDING ORDER (See "STANDING ORDERS").		
ADDRESS :—		
IN REPLY TO GOVERNOR'S OPENING SPEECH :—		
Brought up, 3; motion made (<i>Mr. Carruthers</i>) for adoption of, 4; presented, and His Excellency's answer reported, 5.		
CONGRATULATORY, TO HER MAJESTY THE QUEEN ON THE COMPLETION OF THE JUBILEE YEAR OF HER REIGN :—		
Mr. Speaker informed the House of the receipt of telegram conveying the special thanks of Her Majesty for the Address, 2.		
CONDOLENCE TO HER MAJESTY THE QUEEN ON THE DEATH OF THE EMPEROR OF GERMANY :—		
Motion made (<i>Sir Henry Parkes</i>) for, 530.		
Letter from His Excellency the Governor conveying reply of Secretary of State to, 556		
CONDOLENCE TO HER IMPERIAL MAJESTY THE EMPRESS VICTORIA :—		
Motion made (<i>Sir Henry Parkes</i>) for, 530.		
ADDRESSES AND ORDERS :—		
Motion made (<i>Mr. O'Sullivan</i>) for a return showing what Resolutions for the production of departmental papers, returns, correspondence, &c., have not been attended to, 118; Returns (<i>in part</i>) to Order, laid on Table, 191, 223, 257	1	839, 841, 843
Motion made (<i>Mr. Wall</i>) for a return showing the number of Orders made for production of papers and returns since 1st January, 1886, which have not been complied with, 210; Returns (<i>in part</i>) to Order laid on Table, 257, 334	1	845, 847
Alphabetical Registers of	1	821
ADELAIDE JUBILEE INTERNATIONAL EXHIBITION :—		
Motion made (<i>Mr. Neild</i>) for adjournment of the House in reference to, 543.		
EXECUTIVE COMMISSIONER FOR :—		
Motion made (<i>Mr. Hassall</i>) for a return showing the amount paid by the Treasurer to Mr. J. C. Neild, M.P., since his appointment as, 30; Return to Order, laid on Table, 75	8	1,013
NEW SOUTH WALES COMMISSION :—		
Report of the President, 565	8	985
ADJOURNMENT :—		
SPECIAL, 1, 128, 216, 246, 282, 314, 353 (Easter), 456, 467 (Queen's Birthday).		
OF HOUSE :—		
Before commencement of business, 203, 465.		
For want of Quorum, before commencement of business, 297.		
Do after commencement of business, 108, 321, 599.		
Motion made for, and passed, 12, 17, 30, 36, 53, 65, 77, 82, 85, 91, 99, 119, 123, 137, 140, 203, 211, 222, 248, 268, 288, 304, 309, 328, 329, 354, 357, 362, 366, 374, 381, 386, 391, 404, 410, 422, 426, 434, 437, 446, 452, 464, 465, 476, 481, 487, 494, 496, 502, 509, 515, 520, 526, 538, 544, 549, 554, 561, 567, 580, 587, 603, 610, 615, 628.		
Motion made for, and withdrawn, 53, 246, 370, 587.		
Motion made for, and House counted out, 108.		
Motion made for, under Additional Standing Order No. 1, on the subjects stated below, and negatived,—		
Publication of Book called "The Introduction of Parliamentary Government in New South Wales," 30.		
Increased prevalence of gambling in shops occupied by Chinese, 35.		
Payment of £16,000 for Evans's Truck Patent, and withdrawn, 53.		
Answer given to a question (Major Parrott's Military Report), 64.		
Replies in reference to paragraphs in newspapers commenting on a compromise alleged therein to have been recently effected by Sir Henry Parkes with his creditors, some of whom are his colleagues in the present Government, 70.		
Gross misrepresentation of Members of the Opposition by the Minister of Public Instruction at Tuena, 88.		
Language used by Minister of Public Instruction in referring to the Opposition, 103.		
Unsatisfactory answer of Minister for Mines <i>re</i> deputation from Newcastle <i>re</i> Sand-drift, 119.		
Statement of the Colonial Secretary as to dealing with measures before Parliament and other matters relating to the government of the Colony, 123.		
Neglect of Lands Department in not providing roads to give access to railway stations, towns, and to main roads, 135.		
Condition of Public Business, 140.		
Facts disclosed in papers laid on Table in case <i>Regina v. Pruen</i> , 151.		
Action taken by the Police in the prosecution of persons for selling the paper known as <i>The Sunday Times</i> , 186.		
Safety of Harbour Steamers and the laws for the management of steamers which are declared by the Chief Justice to be monstrous, 192.		
Answer given by Secretary for Public Works on the question of survey of railway route to Inverell, 197.		
Statements of Examiner of Coal-fields, in papers laid upon the Table, and reflecting upon Commissioners Report, <i>re</i> Bulli Explosion, 200.		
Unworthy appointments to the Commission of the Peace, made by the Ministry now in power, 208.		
Non-production of certain Schedules, 215.		
Arrest of Members, 224.		
Report on the prevalence of leprosy at Honolulu, and other matters affecting public health, 228.		
Proposed expenditure on the State House, and withdrawn, 246.		
Papers laid on Table relating to purchase of a "Gulcher" and plant by Telegraph Department, &c., 246.		
Unsatisfactory administration of the Land Laws by the Minister for Lands, 263.		
Decision of the Privy Council in <i>Tearle v. Edols</i> , and the reservation of forfeited selections within the geographical boundaries of the pastoral holdings, 287.		
Condition of railway labourers on the Blayney and Cowra line, and matters of public importance connected therewith, 325.		
Removal of a large number of men from railway workshops and sheds at Bathurst, and to the fact that the answers given in this Chamber by the Minister were inaccurate and misleading, 328.		
Attack made in an article in the <i>Sydney Morning Herald</i> on the Honorable Member for Northumberland, Mr. Melville, 335.		
Action of the Home Government in reference to the Divorce Extension Bill, 342.		
Certain parties, M's.L.A., and others occupying a number of compartments in railway carriages, where only one or two persons occupy the compartments without the number of tickets, 378.		
Statements made in the public Press reflecting upon the Administration of Justice, 429.		

REFERENCES TO THE VOTES AND PROCEEDINGS, VOL. I—13TH PARLIAMENT—SESSION, 1887-8.	PAPERS.	
	VOL.	PAGE.
A		
ADJOURNMENT—(continued) :—		
OF HOUSE—(continued) :—		
Motion made for, and negatived— <i>continued</i> .		
Decision of the Supreme Court, and the intention of the Government in regard thereto, in the matter of the illegal detention of certain Chinese, 463.		
Mineral Conditional Purchases made by the Lane Family and Mr. Withers on the Teralba Coal-mining Reserve, 493.		
Railway Policy of the Government, 513.		
Remission of £900 of a fine £1,000 inflicted on the Captain of the S.S. "Chelydra" for carrying more than the legal number of Chinese, 525.		
Adelaide Jubilee International Exhibition, 543.		
Statement of Treasurer in reference to state of the Public Accounts, 561.		
Necessity of immediate legislation in reference to the fencing clauses of the existing Land Law, 565.		
Refund of abatements in rents in cases where Crown Lessees have appealed and the rent has been reduced, 586.		
Certain actions of the present Government; and Point of Order raised that "a definite matter" of urgent public importance had not been stated in the notice, and Mr. Speaker pointed out that, by a previous decision of the House, he had been relieved of the responsibility of deciding the point which should have been taken before the motion was stated, 635.		
OF DEBATE :—		
Motion made for, and passed, 35-6, 77, 99, 104, 115, 130, 140, 145, 225, 259, 296, 309, 315, 326, 335, 338, 525, 547.		
Motion made for, and passed, to take precedence, 169, 181, 208, 210, 216.		
Do and negatived, 4, 186, 221, 253.		
ADMINISTRATION OF JUSTICE (See also "ATTORNEY-GENERAL") :—		
EMERY v. BARCLAY :—		
Motion made (<i>Mr. Martin</i>) for all papers and plans retained at the Supreme Court, 352.		
REGINA v. PRUEN :—		
Motion made (<i>Mr. O'Mara</i>) for all depositions, letters, &c., relating to case of, trial at Quarter Sessions, Bathurst, 30; Return to Address laid on Table, 88	2	681
Motion made that this House do now adjourn to call attention to fact disclosed in Papers, and negatived, 151.		
DISTRICT COURT BAILIFFS :—		
Motion made (<i>Mr. Gould</i>) for a return showing names, and amount of fees received by each, distinguishing the several services for which the fees were paid, during 1886 and to 30th June, 1887, 48; Return to Order laid on Table, 492	2	635
PENAL ADMINISTRATION :—		
Report respecting proposed changes in, laid on Table, 52	4	1213
JUVENILE OFFENDERS :—		
Motion made (<i>Mr. Thompson</i>) for return in continuation of a previous one, up to 30th June, 1887, 97; Return to Order laid on Table, 165	2	707
ROBERT COYLE :—		
Motion made (<i>Mr. Walker</i>) for a Select Committee to inquire into the treatment of, whilst a prisoner in Berrima and other gaols, and debate interrupted by Government Business, 123; Order of the Day postponed, 131; Order of the Day discharged 252.		
CASE OF W. A. HOPKINS :—		
Motion made (<i>Mr. Hassall</i>) for all papers in connection with, who was sentenced to six weeks imprisonment for assault, 128; Return to Order laid on Table (not printed), 181.		
MR. ADDISON, STIPENDIARY MAGISTRATE :—		
Motion made (<i>Mr. O'Sullivan</i>) for a Select Committee to inquire into charges of misconduct alleged against, by a meeting of licensed cabmen and drivers, and debate adjourned, 130; Order of the Day, postponed, 147; debate resumed and motion negatived, 234.		
Return of cases heard at the Water Police Court by, on 17th November, 1887, laid on Table (not printed), 174.		
Petition from C. Prince, Chairman of meeting of licensed drivers expressing dissatisfaction with, when adjudicating in cases in which they were concerned, and praying the appointment of a Select Committee, 185	2	625
THE REV. H. H. BRITTON, OF RYDE :—		
Motion made (<i>Mr. J. S. Farnell</i>) for all documents, depositions, &c., in the case of alleged arson against, and any letters respecting the conduct of Mr. Manning, Coroner, at Ryde, 136; Return to Address laid on Table, 326	2	639
Motion made (<i>Mr. Frank Farnell</i>) for letters written to the Minister of Justice by Mr. J. E. Manning, on 2nd December, 1886, and 20th January, 1887, in reference to the alleged arson case at Ryde, 344; Return to Address laid on Table, 415	2	679
LATE ACTING POLICE MAGISTRATE AT COROWA :—		
Returns to Order (<i>Second Session</i> , 1887), laid on Table (not printed), 144, 389; ordered to be printed, 454	2	631
SUPREME COURT :—		
Rules of, laid on Table, 257, 267, 635	2	709, 711, 727
CLAIM OF CHARLES STEVENS :—		
Report of Select Committee adopted, 268.		
JUDGE DOCKER :—		
Motion made (<i>Mr. J. P. Abbott</i>) for papers, &c., relating to claim for travelling expenses by, 287; Return to Address laid on Table, 451	2	617
SHEPHERD v. LEONARD :—		
Motion made (<i>Mr. Dawson</i>) for papers in case of, 303; Return to Order laid on Table (not printed), 341.		
CASE AGAINST MR. T. W. CHAMBERS, AT TIBOOBURRA :—		
Motion made (<i>Mr. J. P. Abbott</i>) for papers relative to, 320. Return to Address laid on Table (not printed), 524.		
CASE OF QUEEN v. BOWLER :—		
Motion made (<i>Mr. Stokes</i>) for address to the Governor for papers, &c., 403; Return to Address laid on Table, 429	2	703
PRISONS :—		
Annual Report on, for 1887, laid on Table, 420	4	1223
POLICE MAGISTRATE FOR PARRAMATTA :—		
Return to Order (<i>Session</i> 1885) laid on Table, 425	2	627
Motion made (<i>Mr. Frank Farnell</i>) for all papers in reference to appointment of, 429; Returns to Addresses laid on Table, 451, 635	2	629
Motion made (<i>Mr. Vaughn</i>) for adjournment of the House in order to call attention to statements made in the public Press reflecting on, 429.		

REFERENCES TO THE VOTES AND PROCEEDINGS, VOL. I—13TH PARLIAMENT—SESSION, 1887-8.	PAPERS.
	VOL. PAGE.
A	
ADMINISTRATION OF JUSTICE—(continued):—	
COMMISSIONS TO PROSECUTE FOR THE CROWN:—	
Motion made (<i>Mr. McElhone</i>) for return showing particulars of, 437; Return to Order laid on Table, 462.....	2 623
PUBLIC INSTRUCTION ACT:—	
Information respecting prosecutions under the compulsory clause laid on Table, 437.....	4 501
CROWN v. WALLSEND COAL COMPANY:—	
Correspondence respecting laid on Table, 524.....	8 259
DISTRICT COURTS ACT OF 1858:—	
Annual returns under 163 section, laid on Table, 524.....	2 735
MAXWELL ANNE, ASSAULT WITH INTENT ON:—	
Motion made (<i>Mr. Buchanan</i>) for Address to Governor for copies of all papers in reference to case of, tried at Lismore Quarter Sessions, 560; Return to Address laid on Table, 635.....	2 689
REGINA v. CHRISTENSON:—	
Motion made (<i>Mr. Kelly</i>) for Address for papers in case of, 619.	
ADMINISTRATION OF LAND LAWS (See "CROWN LANDS").	
"AFGHAN S.S.":—	
Return respecting Chinese passengers by, laid on Table, 454.....	2 211
AGRICULTURAL COLLEGE:—	
Motion made (<i>Mr. Kethel</i>) for address to the Governor for establishment of, and by leave withdrawn, 370.	
AGRICULTURAL COLLEGE AND EXPERIMENTAL FARMS BILL:—	
Motion made (<i>Sir Henry Parkes</i>) for Committee of the Whole, 416.	
AGRICULTURAL PRODUCTS:—	
IMPORT DUTIES:—	
Motion made (<i>Mr. Copeland</i>) that it is desirable to encourage the agricultural interests, by imposing import duties on grain, pulse, beans, peas, hay, barley, oats, chaff, flour, meal, bran, pollard, sharps, and potatoes, and debate adjourned, 169; negatived, 233.	
Petition presented (<i>Mr. Copeland</i>) from residents of New England representing that the farming industry is in a deplorable condition, and praying the House to grant relief &c., and read by the clerk, 492.....	3 873
Petition presented (<i>Mr. Copeland</i>) from farmers, Inverell District in favour of a specific duty on grain, 492.....	3 871
Motion made (<i>Mr. Copeland</i>) for moderate import duties on agricultural productions grown in the Colony on all articles that can be manufactured in the Colony, and the question not being put at 7 o'clock, Government business takes precedence, 493; Order of the Day postponed, 506; Debate resumed and question negatived, 509.	
Petition presented (<i>Mr. Crouch</i>) from Casino Political League in favour of, and praying the House to pass <i>Mr. Copeland's</i> resolutions, 496.....	3 869
Petition presented (<i>Mr. Copeland</i>) from farmers, agriculturalists and labourers of Central New England, praying for import duties on agricultural productions that can be grown in the Colony, and read by the Clerk, 505.....	3 877
Petition presented (<i>Mr. Ewing</i>) from Public Meeting at Tatham in favour of, 519.....	3 875
AGRICULTURAL SOCIETIES:—	
Motion made (<i>Mr. Gormly</i>) for Committee of the Whole, to consider whether a sum equal to their annual income be granted in aid of, 238; Order of the Day postponed, 252, 329; House in Committee, and resolution agreed to, 386.	
ALBURY:—	
PUBLIC PARK:—	
Notification, under the Lands for Public Purposes Acquisition Act, of the resumption of land for, laid on Table, 6.....	5 827
AND WAGGA WAGGA LAND OFFICES:—	
Motion made (<i>Mr. Day</i>) for all papers, reports, &c., sent in by the Board appointed to inquire into the working of, 23.	
REMOVAL OF SURVEY OFFICES FROM, TO WAGGA WAGGA:—	
Motion made (<i>Mr. Day</i>) for all papers, reports, telegrams, and recommendations respecting, 41; Return to Order laid on Table, 476.....	5 161
ALBURY CATTLE SALE-YARDS BILL:—	
Petition presented (<i>Mr. Day</i>) to proceed with Bill under 65th Standing Order, presented and read 1 ^o , 17; <i>Point of Order</i> that Bill was improperly before the House overruled, 42; read 2 ^o , committed, reported with amendments, and report adopted, 43; read 3 ^o , passed, and sent to Council, 49; returned with amendments, 113; Order of the Day postponed, 122; amendments agreed to with amendments, 192; Message to Council, 197; Council agrees to amendments upon their amendments, 200; Assent reported, 219.	
ALLEN, JOHN (See "CROWN LANDS PURCHASES VALIDATION BILL.")	
ALLEN, WILLIAM JOHNSTON, ESQUIRE (See also "ELECTORAL"):	
Return of Writ for Paddington, certifying to election of, 249; sworn, 253; Petition laid on Table to refer Seat to Elections and Qualifications Committee, Petition referred to Elections and Qualifications Committee, 269; Report brought up, 296.....	1 891
ALPHABETICAL REGISTERS:—	
Addresses and Orders passed during the Session, &c.....	1 821
Bills dealt with during the Session.....	1 819
AMMUNITION MANUFACTORY:—	
Correspondence respecting proposed establishment of, laid on Table, 479.....	2 41
ANDERSON'S COMBINATION TRUCKS (See "RAILWAYS").	
ANGLEDPOOL (See "TELEGRAPHS").	
ANIMALS (See "DISEASED ANIMALS AND MEAT BILL").	
ANIMALS INFECTIOUS DISEASES BILL:—	
Message from Governor, 314; Standing Orders suspended, Motion made (<i>Mr. Garrett</i>) for Committee of the Whole, 326; House in Committee, Resolution reported and agreed to, presented and read 1 ^o , read 2 ^o and committed, reported, report adopted, read 3 ^o , passed and sent to Council, 335; Returned without amendment, 338; Assent reported, 378.	8 665
ANNIVERSARY (See "CENTENARY OF THE COLONY").	
ANSWERS AND QUESTIONS:—	
Sessional Order passed, 10.	
APPEALS (See "CROWN LANDS").	
APPEALS ACT (See "SUPREME COURT APPEALS ACT AMENDMENT BILL").	
APPLICATIONS (See "MINING").	
TMENTS (See "CIVIL SERVICE").	

INDEX.

REFERENCES TO THE VOTES AND PROCEEDINGS, VOL. I—13TH PARLIAMENT—SESSION, 1887-8.	PAPERS.	
	VOL.	PAGE.
A		
APPROPRIATION BILL:—		
Ordered (<i>Mr. Burns</i>) founded on Resolutions of Ways and Means, Nos. 10 and 11, presented and read 1 ^o , 627; read 2 ^o ; committed, reported without amendment; report adopted; read 3 ^o , passed and sent to Council, 639; returned without amendment, 642; assented to in Council Chamber, 642.		
ARBITRATION (See "TRADES CONCILIATION BILL").		
ARDILL, MR. JOHN ROCHE:—		
Petition from, that owing to the action of the Surveyor-General, he is aggrieved, and has suffered loss, and praying relief, presented 43	2	139
Motion made (<i>Dr. Ross</i>) for correspondence, petitions, claims, &c., for compensation for work done by, as a licensed surveyor, 155; Return to Order laid on Table (not printed), 429.		
ARTILLERY, PERMANENT (See "MILITARY"; also "ELECTORAL").		
ASSEMBLY (See also "ADJOURNMENT"; also "CHAIRMAN OF COMMITTEES"; also "CLERK OF ASSEMBLY"; also "CLOSURE OF DEBATE"; also "DISORDER"; also "PARLIAMENT"; also "PRIVILEGE;" also "SPEAKER;" also "PARLIAMENTARY REPRESENTATIVES ALLOWANCE BILL"):		
Opening of Session, 1.		
Prorogation Speech, 643.		
Usher of Black Rod delivers Message, 1.		
Vacant Seats, 1, 73, 222, 269, 419.		
Issue and Return of Writ reported, 1, 73, 87, 249 ⁽³⁾ , 303, 339, 463.		
Members sworn, 76, 87, 249, 253 ⁽²⁾ , 303, 342, 463.		
Members named, 156 ⁽²⁾ , 184.		
Members declared guilty of persistent disorder and removed from the Chamber by the Sergeant-at-Arms, 220 ⁽¹⁾ , 221 ⁽⁷⁾ .		
Member committed to custody of Sergeant-at-Arms, 480.		
Member in custody of Sergeant-at-Arms, 483.		
Member discharged from custody of Sergeant-at-Arms, 485.		
Member's name discharged from Select Committee, 432, 462.		
Member's name added to Select Committee, 89, 280.		
Member's name substituted for another on Select Committee, 585.		
Leave of Absence to Member, 17, 112, 308, 361, 437.		
Leave of Absence to Chairman of Committees, 397, 424.		
Disorder reported from Committee of the Whole and Member removed by Sergeant-at-Arms and suspended for the remainder of the sitting, 345.		
Disorderly words reported from Committee of Supply, 452.		
Disorder reported from Committee of the Whole, 479.		
Words of heat used by Member and withdrawn and apologised for, 374.		
Irregularities in Election and Proclamation curing same, reported, 73.		
<i>Pro forma</i> Bill read 1 ^o , 2.		
Governor's opening Speech, 2; Address-in-Reply, 3, 4; Answer to Address-in-Reply, 5.		
Sittings after midnight, 4, 30, 53, 65, 77, 90, 99, 115, 119, 123, 136, 140, 146, 152, 162, 169, 186, 198, 210, 220, 242, 248, 264, 288, 296, 304, 329, 345, 361, 374, 381, 390, 422, 425, 430, 434, 442, 452, 455, 469, 476, 480, 487, 494, 496, 501, 509, 514, 520, 526, 538, 544, 548, 554, 574, 580, 587, 603, 615, 619, 628, 639.		
Continuous Sitting, 619, 628.		
Elections and Qualifications Committee, 17, 37, 53 ⁽²⁾ , 55 ⁽²⁾ , 145, 269, 287, 296, 548.		
Deputy Speaker's Commission to administer the Oath of Allegiance, 46.		
Standing Order (Right of Reply)—Additional—passed, 23; Speaker authorized to present to Governor for approval, 28; approval reported, 31.		
Standing Order—Additional—No. 5, 128.		
Standing Orders suspended, 191, 241, 294, 295, 326, 361, 344, 385, 409, 455, 479, 553, 578.		
Standing Orders referred to Standing Orders Committee, 353; Report brought up, 476; ordered to be considered in Committee, 479; Order of the Day postponed, 529, 566, 592.		
Sessional Orders passed, 9, 10 ⁽⁶⁾ , 11 ⁽⁹⁾ , 12 ⁽²⁾ , 89 ⁽³⁾ , 103, 408.		
Sessional Order rescinded, 325.		
Additional Sitting Day passed, 103, 585 ⁽²⁾ .		
Hour of meeting of the House, 224, 303.		
Government Business takes precedence at 7 o'clock, 103, 123, 140, 166, 234, 408, 422, 433, 452, 476, 493, 508, 525, 543, 560, 561, 580, 609.		
Business fixed for a future day to take precedence, 169, 181, 208, 210, 216.		
Interruption to Proceedings, 76, 296.		
Select Committee appointed by ballot, 30.		
Standing Committee appointed by ballot, 508.		
Records of the House removed from custody of the Clerk, 51; motion of <i>privilege</i> moved respecting, Records returned, and motion by leave withdrawn, 53.		
Speaker retires, Deputy Speaker takes Chair, Speaker resumes Chair, 579.		
Report from Select Committee referred back to Committee, 200.		
Order of the Day discharged, 77, 107, 137, 145, 146, 185, 192, 233, 241, 246, 252 ⁽²⁾ , 309, 325, 506 ⁽²⁾ , 507, 508 ⁽²⁾ , 608 ⁽²⁾ .		
Bill withdrawn, 107, 137, 145, 146, 192, 233, 241, 246, 349, 389, 506, 508, 585, 608.		
Bill recommitted, 98, 152, 201, 373, 507, 547, 586.		
Recommittal of Bill negatived, 98, 507, 586, 595.		
Notices of Motions of General Business postponed in a bunch, 162, 208, 242, 248, 487, 628.		
Notice of Motion of General Business postponed, 502.		
Orders of the Day of General Business postponed in a bunch, 248, 430, 487.		
Orders of the Day of Government Business postponed in a bunch, 417, 430, 463, 468, 487, 502, 509, 628.		
No Tellers in Division, 59, 140.		
Apology from Mr. Thos. Robertson, for having interrupted proceedings of the House, read by Mr. Speaker, and accepted, 79.		
Entry in Votes and Proceedings expunged by Order, 90, 91.		
Ministerial Statement made by Sir Henry Parkes, 123, 252, 264, 361, 364, 404, 451, 501, 613, 641.		
Motion made adjudging Member guilty of contempt, 156 ⁽²⁾ .		
Previous Question moved and negatived, 165.		
Death of Member of, reported, 249.		
Retirement of Mr. Jones, Clerk of, 250.		
Commission appointing Mr. Frederick William Webb to be Clerk produced, and Mr. Webb sworn, 285.		

REFERENCES TO THE VOTES AND PROCEEDINGS, VOL. I—13TH PARLIAMENT—SESSION, 1887-8.		PAPERS.	
		VOL.	PAGE.
A			
ASSEMBLY—(continued):—			
Motion made for Member to be heard, 302 ⁽²⁾ .			
Notice of Motion to take precedence of all other business, 328.			
Resolutions, fixing Business for other than a sitting day, rescinded, 585.			
General Orders to take precedence of Motions on Fridays, 593.			
Votes and Proceedings, 1 to 121	1	1	
Business undisposed of at close of Session	1	645	
Attendance of Members in Divisions and Counts-out during the Session ..	1	653	
Business of the Session	1	655	
Weekly Reports of Divisions in Committee of the Whole, Nos. 1 to 22.....	1	657	
Weekly Abstracts of Petitions received, Nos. 1 to 37	1	745	
Alphabetical Registers of Bills	1	819	
Alphabetical Registers of Addresses and Orders.....	1	821	
Standing and Select Committees appointed during Session	1	831	
Explanatory Abstracts of Sums estimated and voted	3	851	
FREE RAILWAY PASSES TO EX-MEMBERS OF:—			
Motion made (<i>Mr. Haynes</i>) that Resolution affirming that Members returned to three Parliaments on ceasing to be Members shall be entitled to a permanent free railway pass, be rescinded, and debate adjourned, 129; Order of the Day postponed, 433; Order of the Day discharged, 506			
FRANKING MEMBERS' CORRESPONDENCE ON PUBLIC BUSINESS:—			
Motion made (<i>Mr. Ewing</i>) that all letters on public business incidental upon the representation in Parliament of an Electorate shall be carried free by post, 24; and negatived, 25.			
PAYMENT OF MEMBERS (See also "PARLIAMENTARY REPRESENTATIVES ALLOWANCE BILL") :—			
Motion made (<i>Mr. Fletcher</i>) for Committee of the Whole to consider the necessary steps to be taken to make provision in the Estimates for, 28; House in Committee, and Resolution agreed to, 42.			
POSTAGE ON CORRESPONDENCE RE-DIRECTED FOR MEMBERS:—			
Motion made (<i>Mr. Chanter</i>) for no further charge for, and motion not having been put at 7 o'clock, Government business took precedence, 433.			
LIGHTING BUILDINGS WITH ELECTRIC LIGHT:—			
Motion made (<i>Mr. Thompson</i>) for all recommendations, tenders, correspondence, &c., in connection with, 103.			
ADDRESSES AND ORDERS:—			
Motion made (<i>Mr. O'Sullivan</i>) for a return showing what Resolutions for the production of departmental papers, returns, correspondence, &c., have not been attended to, 118; Returns (<i>in part</i>) to Order laid on Table, 191, 223, 257	1	839, 841, 843	
Motion made (<i>Mr. Wall</i>) for a return showing the number of orders made, for production of papers and returns since 1 January, 1886, which have not been complied with, 210; Returns (<i>in part</i>) to an Order, laid on Table, 257, 334	1	845, 847	
CENTENNIAL INTERNATIONAL EXHIBITION, MELBOURNE:—			
Telegram from Speaker of Legislative Assembly, Victoria, conveying invitation to, read by Mr. Speaker, 563.			
SELECT COMMITTEES ON PRIVATE BILLS:—			
Motion made (<i>Mr. Barbour</i>), for Committee of the Whole to consider the question of remuneration of Members attending on, 608.			
ASSENT TO BILLS (See "MESSAGES").			
ASSISTANT-EXAMINER OF ACCOUNTS, TREASURY:—			
Return respecting applications for position of, laid on Table, 524.....	2	111	
ASSOCIATION CRICKET GROUND:—			
Motion made (<i>Mr. McElhone</i>) for a return showing all moneys received, and amount expended by the Trustees, giving particulars, 215; Return to Order, laid on Table, 408	8	1021	
Return respecting Trustees of, laid on Table, 519	8	1023	
TRUSTEES' ACCOUNTS:—			
Motion made (<i>Mr. McElhone</i>), for audit and report on; and the Question not having been put at 7 o'clock, Government Business took precedence, 609.			
ASYLUMS:—			
GOVERNMENT:—			
Reports, &c., from the Manager, Matrons, Superintendents, and others, on the Report from the Board appointed to inquire into, laid on Table, 82.....	4	617	
INFIRM AND DESTITUTE:—			
Correspondence as to accommodation and treatment of ophthalmic patients, laid on Table, 82.....	4	607	
ATTENDANCES OF MEMBERS IN DIVISIONS AND COUNTS OUT:—			
Sessional paper	1	653	
ATTENDANCE OFFICERS (See "EDUCATION").			
ATTORNEY-GENERAL:—			
Return, showing names of gentlemen who have held the office under Responsible Government, with the amount of Patent Fees received by each, laid on Table, 144	2	615	
Motion made (<i>Mr. Dibbs</i>) that the practice of Government paying Counsel's fees to, in addition to his salary, is fraught with danger, and ought to be discontinued forthwith, and debate adjourned, 140; Order of the day postponed, 232; discharged, 586.			
Resignation of office of, by Mr. Wise, 252.			
Acceptance of office of, by Mr. Simpson, 264.			
Opinion of Mr. Dalley on Section 4 of Crown Lands Alienation Act of 1861, laid on Table, 500....	5	109	
ATTORNEYS BILLS OF COSTS AND PRACTICE OF CONVEYANCING AMENDMENT BILL:—			
Motion made (<i>Mr. Frank Farnell</i>) for leave to bring in, presented and read 1 ^o , 191; Order of the Day postponed, 224, 252; read 2 ^o and committed 320; Order of the Day postponed, 341, 386, 433, 493, 579, 593.			
Petition from certificated conveyancers of the Supreme Court of New South Wales, praying for an amendment of the first clause, presented, 277	8	1025	
AUBURN PARK ROAD TRUST:—			
Motion made (<i>Mr. Frank Farnell</i>) for all papers and minutes in connection with, 196; Return to Order laid on Table, 341.	5	967	
AUDITOR-GENERAL:—			
Report of, on Statement of Receipts and Expenditure for the Year 1886, laid on Table, 2	3	509	
Report of, on Statement of Receipts and Expenditure for 1887, laid on Table, 563.....	3	657	
AUSTRALIA (See "COLONY OF AUSTRALIA BILL").			

REFERENCES TO THE VOTES AND PROCEEDINGS, VOL. I—13TH PARLIAMENT—SESSION, 1887-8.	PAPERS.	
	VOL.	PAGE.
A		
AUSTRALASIAN NAVAL FORCE BILL :—		
Motion made (<i>Sir Henry Parkes</i>) for Committee of the Whole—motion made, “That Question be now put?”— <i>Disorder</i> in division, and Member named, and motion of contempt moved, bars opened, another Member named, and motion of contempt moved, 156; and withdrawn, and motion That Question be now put, withdrawn,—original question carried, 157; Message from Governor, 157; House in Committee, Resolution agreed to, presented and read 1 ^o , 166; motion made for 2 ^o , amendment “This day six months” moved and debate adjourned, 181; debate resumed, amendment negatived, 186; read 2 ^o and committed, 187; further considered in Committee, 197; reported without amendment and report adopted, 198; read 3 ^o , passed, and sent to Council, 210; returned without amendment, 230; assent reported, 237.	2	67
AUSTRALASIAN STEAM NAVIGATION COMPANY'S WHARF :—		
PURCHASE BY THE GOVERNMENT OF LAND ADJOINING :—		
Motion made (<i>Mr. Melville</i>) for a Select Committee to inquire into, Committee appointed by ballot, 30; Report brought up, 305.....	3	917
Motion made (<i>Mr. Dibbs</i>) for an Address to the Governor that the evidence of the Select Committee discloses injudicious and unsatisfactory administration by the Government, and that the amount paid was in excess of its value, and negatived, 329.		
Correspondence respecting, laid on Table, and referred to Select Committee, 52	3	1011
PURCHASE BY THE GOVERNMENT OF :—		
Motion made (<i>Mr. Trickett</i>) for all claims, correspondence, valuations, &c., connected with, 136 Return to Order laid on Table, 191	3	1013
AUSTRALIAN MUTUAL PROVIDENT SOCIETY'S ACTS AMENDMENT BILL :—		
Received from Legislative Council and on motion (<i>Mr. Day</i>) read 1 ^o , 326; Order of the Day postponed, 365; Question proposed, That this Bill be now read 2 ^o , and the motion not having been put at 7 o'clock, Government business took precedence, 452; Order of the Day postponed, 476; read 2 ^o , committed, reported without amendment, report adopted, 506; read 3 ^o , passed, returned to Council without amendment, 512; assent reported, 524.		
AUTOMATIC ELECTRIC CARS :—		
Correspondence respecting, laid on Table, 373	6	1125
B		
BAILIFFS (Sec “ADMINISTRATION OF JUSTICE”).		
BALLOT :—		
For Select Committee, 30.		
For Parliamentary Standing Committee on Public Works, 508.		
BALLOTING FOR SELECT COMMITTEES :—		
Sessional Order passed, 11.		
BALMAIN (See “BOROUGH OF BALMAIN WHARVES BILL;” also “WHARVES”).		
BALRANALD :—		
WATER SUPPLY :—		
Notification under Country Towns Water and Sewerage Act, authorizing the construction of works for, laid on Table, 6	5	881
BANK LIABILITIES AND ASSETS :—		
For quarter ended 30th June, 1887, laid on Table, 5	3	843
For quarter ended 30th September, 1887, laid on Table, 135	3	845
For quarter ended 31st March, 1888, laid on Table, 475	3	847
BANKING, LAND, BUILDING, AND INVESTMENT COMPANIES :—		
General Summary of Liabilities and Assets for quarter ended 31 March, 1888, laid on Table, 475..	3	849
BANKRUPT (See “PRIVILEGE”).		
BANKRUPTCY ACT OF 1887 :—		
General Rules under, laid on Table, 257, 267, 635	2	709, 711, 727
Regulations for 1887, 451	2	731
BANKRUPTCY ACT AMENDMENT BILL :—		
Motion made (<i>Mr. William Clarke</i>) for leave to bring in, presented, and read 1 ^o , 586; read 2 ^o , committed, reported with an amendment, report adopted, 594; read 3 ^o , passed, sent to Council, 598; returned with an amendment, 614; amendment agreed to, 627; assent reported, 629.		
BANKRUPTCY BILL :—		
Motion made (<i>Mr. Wise</i>) for leave to bring in, 16; House in Committee, Resolution agreed to, presented and read 1 ^o , Message from Governor, 29; motion made for 2 ^o and debate adjourned, 35; resumed, 49; read 2 ^o and committed, 50; further considered in Committee, 53, 65, 71, 82, 85; reported with amendments and report adopted, 85; recommitted reported 2 ^o , 97, 98; report 2 ^o adopted, 104; read 3 ^o and passed, 106; sent to Council, 107, returned with amendments, 158; amendments agreed to and disagreed to, 166; Message to Council, 174; Council does not insist on its amendments disagreed to, 185; assent reported, 219.	2	729
BARCELONA :—		
Despatches respecting trade in wheat with Australia, laid on Table, 335, 475	8	1309, 1311
BARCLAY, ISAAC (See also “CROWN LANDS”) :—		
Motion made (<i>Mr. Martin</i>) for a Select Committee to inquire into Claim of, for compensation for losses sustained in defending his title to land held under Crown Grant, 165; report brought up, 609	5	487
BARLING, MR. JOSEPH (See “CIVIL SERVICE”).		
BARMAIDS :—		
EMPLOYMENT OF, IN PUBLIC-HOUSES :—		
Petition from Women's Christian Temperance Union and others, that Licensing Law may be amended so as to prohibit, presented, 22.....	7	711
BARRIER RANGES (See “RAILWAYS”).		
BARRISTERS BILL :—		
Motion made (<i>Mr. J. P. Abbott</i>) for leave to bring in, 123.		
BATH, CHARLES :—		
Petition to be heard by counsel, attorney, or agent, before the Select Committee on Silverton Tramway Act Amending Bill, presented, 341.....	2	1097
BATHGATE, MESSRS. LEONARD AND (See “ROADS”).		
BATHURST TO BOURKE (See “RAILWAYS”).		
BEATY, MR. J. M. :—		
Petition from, in reference to public services, and praying for consideration of his case, 463.....	2	141

REFERENCES TO THE VOTES AND PROCEEDINGS, VOL. I—13TH PARLIAMENT—SESSION, 1887-8.		PAPERS.	
		VOL.	PAGE.
B			
BEER (See "SPIRITS").			
BEER DUTY ACT:—			
Regulations under, laid on Table, 35		3	883
BEHAN, DANIEL:—			
LATE SERGEANT IN NEW SOUTH WALES ARTILLERY:—			
Motion made (<i>Mr. Alfred Allen</i>) for a Select Committee to inquire into discharge of, 71; name added to Committee, 89.			
BENN, ZACHARY, CONDITIONAL PURCHASE OF (See "CROWN LANDS").			
BENNETT, MR. C. E.:—			
Report of, on Prospect Dam, laid on Table, 529		5	840
BEXLEY (See "RAILWAYS").			
BILLS OF COSTS (See "ATTORNEYS BILLS OF COSTS AND PRACTICE OF CONVEYANCING AMENDMENT BILL").			
BILLS:—			
Recommitted, 98, 152, 201, 373, 507, 547, 583.			
Recommittal negatived, 507, 586, 595.			
Withdrawn, 107, 137, 145, 146, 192, 233, 241, 246, 349, 389, 506, 508, 585, 603.			
Brought in on order of leave of former Bill, 246, 349.			
Alphabetical Registers of		1	819
BILLS OF SALE ACT AMENDING BILL:—			
Motion made (<i>Mr. Day</i>) for leave to bring in, 408; presented and read 1 ^o , 420; Order of the Day postponed, 476; read 2 ^o , committed, reported without amendment, report adopted, 507; read 3 ^o , passed, sent to Council, 513.			
BILOELA (See "COCKATOO ISLAND").			
BINGERA DISTRICT (See "MINING").			
BISHOP, MR. C. E.:—			
Report of, on Prospect Dam, laid on Table, 529		5	849
BLACK ROD:—			
Delivers Message, from Governor, 1, 642.			
BLAYNEY (See "RAILWAYS").			
BLUE BOOK:—			
For 1887 laid on Table, 479		7	713
BLUE METAL CONTRACT (See "RAILWAYS").			
BLUFF RIVER (See "RAILWAYS").			
BOARDS (See "PASTURES AND STOCK PROTECTION BOARDS"; also "CIVIL SERVICE"; also "ABORIGINALS OF THE COLONY.")			
BOMBALA (See "ROADS"; also "RAILWAYS").			
BONDI ROYAL AQUARIUM:—			
Return respecting occupation of the 100-foot reservation at Dixon's Bay, laid on Table, 553		5	799
BORENORE (See "RAILWAYS").			
BORING OPERATIONS (See "MINING"; also "STOCK").			
BOROUGH OF BALMAIN WHARVES BILL:—			
Petition presented (<i>Mr. Garrard</i>) for leave to proceed with under the 65th Standing Order, presented and read 1 ^o , 9; read 2 ^o , 41; committed, reported with amendments, and Report adopted, 42; read 3 ^o , passed, and sent to Council, 64; returned with amendments, 151; amendments agreed to and Message to Council, 162; assent reported, 171.			
BOTANY BAY:—			
NUISANCE ON NORTH SHORE OF:—			
Motion made (<i>Mr. Stephen</i>) for Committee of the Whole for Address to Governor for provision to be made on the Estimates for the abatement of, and withdrawn, 128.			
PARK RESERVE AT KURNELL:—			
Motion made (<i>Mr. Carruthers</i>) that immediate steps be taken to secure, adjacent to the place where Captain Cook first landed in Australia, and withdrawn, 232.			
BOTANY WEST (See "ROCKDALE MUNICIPALITY RE-NAMING BILL").			
BOTTRELL, DR.:—			
CLAIM OF, TO FORESHORES OF SYDNEY HARBOUR:—			
Motion made (<i>Mr. Lyne</i>) for all papers connected with, 40; Return to Order, laid on Table, 185.		3	885
BOURKE (See also "RAILWAYS").			
Notification under the Country Towns Water and Sewerage Act, completion of Water Supply Works for, 475		5	883
BOWRAL (See "RAILWAYS").			
BOWLER, THE QUEEN v. (See "ADMINISTRATION OF JUSTICE").			
BOYS REFORMATORY (See "REFORMATORY FOR BOYS").			
BRAKE CONTINUOUS (See "RAILWAYS").			
BRAZENOR AND VALENTINE (See "RAILWAYS").			
BREACH OF PRIVILEGE (See "PRIVILEGE").			
BRENNING, CHARLOTTE:—			
Petition from, that she served for three years as a Teacher under the Public Instruction Department, and through being sent to places where great hardships had to be endured, her health was greatly affected, and having applied for removal, her resignation was accepted, and praying the appointment of a Select Committee, presented, 135		4	515
BREWARRINA (See "CUSTOMS"; also "RAILWAYS").			
BRIDGES (See also "ROADS"; also "PARLIAMENTARY STANDING COMMITTEE ON PUBLIC WORKS):—			
HIGH-LEVEL OVER RIVER DARLING:—			
Motion made (<i>Mr. J. P. Abbott</i>) that necessary steps should be taken to inquire into necessity for, at Wilcannia, at Menindie, and Wentworth, 43.			
OVER RIVER MURRAY AT MULWALA:—			
Motion made (<i>Mr. Lyne</i>) for all correspondence, plans, &c., relating to proposed, 64; Return to Order, laid on Table, 277		5	1025
PARRAMATTA RIVER AND IRON COVE:—			
Motion made (<i>Mr. Frank Farnell</i>) for all papers in connection with construction of, 118.			
UPPER MURRAY:—			
Motion made (<i>Mr. Lyne</i>) for papers in reference to erection of, 303.			
VOTE OF £55,000 ON ESTIMATES FOR 1888:—			
Schedule showing proposed distribution, laid on Table, 224		5	1021
CONTRACT FOR OVER THE PATERSON RIVER:—			
Motion made (<i>Mr. Hurley</i>) for Select Committee, 404.			
IRON, BETWEEN PARRAMATTA AND PENRITH:—			
Copy of instructions issued to Professor Warren to inquire and report upon, laid on Table, 429		6	1025

REFERENCES TO THE VOTES AND PROCEEDINGS, VOL. I—13TH PARLIAMENT—SESSION, 1887-8.	PAPERS.	
	VOL.	PAGE.
B		
BRIDGES—(continued) :—		
IRON COVE AND PARRAMATTA RIVER :—		
Return to Order (Second Session 1887, in completion) laid on Table, 432.....	5	823
DUPPLICATED LINE BETWEEN PARRAMATTA AND PENRITH :—		
Motion made (<i>Mr. J. P. Abbott</i>) for papers, plans, &c., in reference to, 519.		
Motion made (<i>Mr. J. P. Abbott</i>) for copy of Professor Warren's report and correspondence relative thereto, 519.		
BRIGADE OFFICE (See "MILITARY").		
BRISBANE TO SYDNEY (See "RAILWAYS").		
BRITTEN, THE Rev. H H., OF RYDE :—		
Motion made (<i>Mr. J. S. Farnell</i>) for all documents, depositions, &c., in case of alleged arson preferred against, and any letters on the subject of the conduct of Mr. Manning, Coroner at Ryde, 136; Return to Address laid on Table, 326	2	639
Motion made (<i>Mr. Frank Farnell</i>) for letters written to the Minister of Justice by Mr. J. E. Manning, on 2nd December, 1886, and 20th January, 1887, in reference to the alleged Arson Case at Ryde, 344; Return to Address, laid on Table, 415	2	679
BROKEN HILL (See "RAILWAYS").		
BROKEN HILL AND SUBURBAN GAS COMPANY'S BILL :—		
Standing Order suspended to admit of presentation of Petition to introduce; Petition presented (<i>Mr. Day</i>), 361; leave given, presented and read 1°, 365; referred to Select Committee, 369; Report brought up, 429; Order of the Day postponed, 476; read 2°, committed, reported with an amendment, report adopted, 507; read 3°, passed, sent to Council, 513.	2	817
BROKEN HILL TRAMWAY BILL :—		
Petition presented (<i>Mr. O'Connor</i>) for leave to bring in, 81; leave given, presented, and read 1°, 147; referred to Select Committee, 155; report brought up, and referred back to Select Committee to take further evidence, 200; report brought up, 2°, 302; Order of the Day postponed, 508.	2	825
Petition from W. P. Macgregor, W. R. Wilson, and W. Jamieson, that their interests will be seriously affected and prejudiced if the Bill be passed, and praying to be heard before the Select Committee, presented, 192.....	2	859
Petition from Inhabitants of Broken Hill and Silverton, praying the House to refuse to sanction the construction of the said Tramway, presented, 295.	2	861
BROKEN HILL WATER SUPPLY BILL :—		
Petition presented (<i>Mr. Brunner</i>) for leave to bring in 344, leave given 348, presented and read 1°, 353; referred to Select Committee, 361; Report brought up, 537.....	2	863
BROKERS (See "MERCANTILE BROKERS").		
BROUGHAM, JAMES KENNEDY (See "MINING").		
BROWNE, THOMAS FREDERIC DE COURCY, ESQUIRE :—		
Return of writ for Wentworth, certifying to election of, reported, 73; sworn, 76.		
BUCHANAN, DAVID, BARRISTER-AT-LAW :—		
Petition in favour of Cremation Bill, presented, 272.....	8	1049
Return of Writ for Central Cumberland, certifying to election of, reported, sworn, 463.		
BULLI COLLIERY :—		
EXPLOSION :—		
Copy of the Attorney-General's opinion respecting, laid on Table, 35.....	8	435
Motion made (<i>Mr. Melville</i>) for all replies, letters, &c., by Mr. Mackenzie respecting Commission's Report on, 185; Return to Order, laid on Table, 196	8	437
Motion made (<i>Mr. Melville</i>) that this House do now adjourn to consider statements of Examiner of Coal-fields in papers laid on Table, and reflecting upon Commissioners report on, and negatived, 200.		
BULLI COLLIERY DISASTER FUND BILL :—		
Received from Legislative Council, and on motion (<i>Mr. Gould</i>), read 1°, 398; Order of the Day postponed, 454; motion made for 2°, and, the Question not having been put at 7 o'clock, Government Business took precedence, 543; Order of the Day postponed, 546, 593, 628.		
BULK SAMPLES OF ORE (See "MINING").		
BUNABA NORTH (See "CROWN LANDS").		
BURNS, THE HONORABLE JOHN FITZGERALD :—		
Ministerial statement made by in reference to revenue receipts and expenditure during quarter ended 31st March, 1888, 361.		
BUSHRANGERS (See "HUSBAND, JAMES H., CLAIM OF").		
BUSINESS DAYS :—		
Sessional Orders passed, 9.		
BUSINESS OF THE HOUSE :—		
Sessional Order passed, 11.		
Precedence of Government Business, Sessional Order passed, 10.		
Do do on Friday, (additional sitting day,) after 7 o'clock, 103, 123, 140, 166, 234.		
Precedence of Government Business, General Business, Sessional Order passed, 10.		
Fixed for a future day to take precedence of all other business, 169, 181, 208, 210, 216.		
Precedence of Government Business on Tuesday at 7 o'clock, 408, 422, 433, 452, 476, 493, 508, 523, 525, 543, 561, 580, 609.		
Friday made a Sitting Day, with General Business to take precedence, 585.		
Monday made a Sitting Day, with Government Business to take precedence, 585.		
Orders of the Day of General Business to take precedence of Motions on Friday, 593.		
PRIVILEGE :—		
Motion made (<i>Mr. Garvan</i>) that Sir Henry Parkes, Colonial Secretary and Premier, having tendered his resignation as a Member, and said resignation having been accepted, this House declines to transact any further business till the Premier occupies his Seat as an elected Member of this House, and negatived, 76.		
BUSINESS OF THE SESSION :—		
Sessional Paper	1	655
BUTCHER, DR. (See "RABBIT PEST").		
BUTTERLEY, MRS. :—		
CLAIM OF :—		
Motion made (<i>Mr. Shey</i>) for Select Committee, and that Return to Order (<i>Second Session, 1887</i>) be referred, 12; Report brought up, 140.	6	647
BY-LAWS :—		
LAI D ON TABLE :—		
University of Sydney, 6, 257 (2)	4	557, 569, 571
Free Public Library, Gunnedah, 257	4	597

INDEX.

REFERENCES TO THE VOTES AND PROCEEDINGS, VOL. I—13TH PARLIAMENT—SESSION, 1887-8.		PAPERS.	
		VOL.	PAGE.
B			
BY-LAWS—(continued) :—			
Laid on Table—(continued) :—			
Municipalities Act :—			
Borough of Gosford, 6, 475,		2	347, 349
Do Alexandria, 6		2	309
Do Newcastle, 6, 257, 273		2	379, 381, 383
Do Armidale, 52		2	441
Do East St. Leonards, 52		2	477
Do West Maitland, 63		2	425
Do Kempsey, 63		2	355
Do Goulburn, 97		2	513
Do Bourke, 97		2	319
Do Marrickville, 128		2	371
Do Narrandera, 174, 403		2	375, 377
Do East Maitland, 191.		2	339
Do Burwood, 223, 257		2	325, 327
Do Waverley, 334		2	421
Do Cootamundra, 369		2	333
Do North Willoughby, 369		2	387
Do Balmain, 403		2	311
Do Mudgee, 484		2	373
Do Bathurst, 543, 619		2	313, 317
Do Cudgegong, 578		2	337
Municipal District of Silvertown, 6		2	397
Do Wentworth, 6, 484		2	423
Do Parkes, 6		2	389
Do Dubbo, 6		2	463
Do Balranald, 6		2	457
Do Glen Innes, 6, 543		2	345
Do Broughton Creek and Bomaderry, 128		2	323
Do Hay, 174.		2	351
Do Gunnedah, 191		2	525
Do Lismore, 257		2	369
Do Coonamble, 257		2	331
Do Cobar, 257		2	329
Do Bowral, 257		2	461
Do Adamstown, 273		2	293
Do Taree, 273		2	405
Do Five Dock, 273		2	489
Do North Illawarra, 369		2	385
Do Waratah, 403		2	551
Do Prospect and Sherwood, 429		2	395
Do Inverell, 429		2	353
Do Port Macquarie, 475		2	391
Do Ulladulla, 475, 501		2	417, 419
Do Tenterfield, 484		2	407
Do Glen Innes, 6		2	499
Do Tumut, 543		2	539
Do St. Peters, 543		2	403
Nuisances Prevention Act :—			
Borough of Woollahra, 6		2	439
Do Newcastle, 97		2	433
Do Gunnedah, 191, 525		2	525
Do North Willoughby, 634		2	437
Municipal District of St. Peters, 6		2	435
Do Dubbo, 6		2	463
Do Balranald, 6		2	457
Do Glen Innes, 6		2	499
Do Armidale, 52		2	441
Do East St. Leonards, 52		2	477
Do Goulburn, 97		2	513
Do Bega, 257		2	427
Do Hamilton, 257		2	429
Do Bowral, 257		2	461
Do Five Dock, 273		2	489
Do Lismore, 302		2	431
Do Waratah, 403		2	551
Do Tumut, 543		2	539
Country Towns Water and Sewerage Act :—			
Borough of Wagga Wagga, 6		5	887
Do Bathurst, 6		5	789
Municipal District of Forbes, 352		5	891
BYROCK (See "RAILWAYS").			
C			
CABLE (See "TELEGRAPHS"; also "TELEPHONES").			
CAMERON, ANGUS, Esq., M.P. :—			
Elected as Chairman of Committees, 9.			
Commission to, as Deputy Speaker, to Administer the Oath of Allegiance, 19.			
Absence of, through illness reported, 70, 383.			
Leave of absence granted to Chairman of Committees on account of serious illness, 397, 424.			
CAREENING COVE (See "RECLAMATION OF NEUTRAL BAY AND CAREENING COVE.")			
CARRIAGE OF WOOD AND OTHER PRODUCE :—			
Original Tenders for, from Railway Station, Redfern, and Darling Harbour, laid on Table (as Exhibits only), 454.			
CASSILIS :—(See "RAILWAYS").			

REFERENCES TO THE VOTES AND PROCEEDINGS, VOL. I—13TH PARLIAMENT—SESSION, 1887-8.	PAPERS.	
	VOL.	PAGE.
C		
CASTINGS FOR HUNTER RIVER DISTRICT :— Tenders for supply of, laid on Table, 308	3	913
CASTLEREAGH AND ELIZABETH STREETS PROPERTY (See "EDUCATION.")		
CASUAL LABOUR BUREAU :— Return respecting, laid on Table, 35	8	1027
CATTLE SALE YARDS (See "WEST MAITLAND CATTLE SALE YARDS BILL.")		
CEMETERIES BILL :— Motion made (<i>Mr. J. P. Abbott</i>) for leave to bring in, presented and read 1 ^o , 397; Order of the Day postponed, 543; discharged and Bill withdrawn, 585.		
CEMETERY :— PRESBYTERIAN, AT MACLEAN :— Motion made (<i>Mr. McFarlane</i>) for a Select Committee to inquire into claims of Messrs. J. Macdonald, F. Mackenzie, and D. Shearer, to be reinstated as Trustees, 71; petition presented on 11th May, 1887, referred, 122; Petition from Moderator of the General Assembly for leave to be represented before the Select Committee, presented, 123	8	1255
ROOKWOOD AND WAVERLEY :— Information respecting the Church of England Chaplains at, laid on Table, 144	8	1263
LAND FOR PUBLIC PURPOSES ACQUISITION ACT :— Resumption of land for Public Cemetery at Singleton, notification laid on Table, 252	8	1223
DEVONSHIRE-STREET :— Return of names of Trustees of, laid on Table, 263. Motion made (<i>Mr. Day</i>) to close, and motion withdrawn, 268.	8	1055
CENSURE (See "VOTE OF CENSURE").		
CENSUS :— Return showing estimated population on 31st December, 1877, of New South Wales and Victoria respectively, laid on Table, 352	7	1393
CENTENARY CELEBRATION ACT AMENDMENT BILL :— Motion made (<i>Mr. Dibbs</i>) for leave to bring in, presented and read 1 ^o , 59; Order of the Day postponed, 103, 192; Order of the Day discharged and Bill withdrawn, 246.		
CENTENARY CELEBRATION ACT AMENDMENT BILL (No. 2) :— Motion made (<i>Mr. Dibbs</i>) that Order of Leave be read, entry in Votes and Proceedings read by Clerk, presented and read 1 ^o , 246; Order of the Day postponed, 252; motion made for 2 ^o , and Debate adjourned, 285; resumed and negatived, 288.		
CENTENARY OF THE COLONY :— Motion made (<i>Sir Henry Parkes</i>) for Committee of the Whole to consider Resolutions to mark in a fitting manner, House in Committee, Resolutions reported and agreed to, 114. Motion made (<i>Mr. Garvan</i>) for Committee of the Whole to consider Resolution offering prizes in connection with the Celebration, 136; Order of the Day postponed, 147; Order of the Day discharged, 185. Statement of amounts paid, or passed for payment, on account of the Celebration, up to 30 April 1888, laid on Table, 437	8	1020
RELIEF TO POOR OF SYDNEY :— Information respecting, laid on Table, 302	8	1031
CENTENNIAL INTERNATIONAL EXHIBITION, MELBOURNE :— INVITATION TO LEGISLATIVE ASSEMBLY :— Telegram from Speaker of the Legislative Assembly, Victoria, conveying, read by Mr. Speaker, 563.		
PORTRAIT OF WILLIAM CHARLES WENTWORTH :— Letter from Executive Commissioner asking for loan of, and Resolution passed against sending, 569.		
CENTENNIAL PARK :— Motion made (<i>Mr. O'Sullivan</i>) for all papers, &c., in connection with scheme of, 208. Motion made (<i>Mr. Dibbs</i>), for papers relating to construction and dedication, 308. Statement of Payments made on account of, from 1st August, 1887, to 21st March, 1888, laid on Table, 352	5	813
PETITION OF RESIDENTS OF WOLLAHRA :— Praying for a gate to be placed at the top of Moncur-street, 505	5	815
CENTRAL CUMBERLAND (See "ELECTORAL").		
CENTRAL POLICE COURT (See "PARLIAMENTARY STANDING COMMITTEE ON PUBLIC WORKS.")		
CHAIRMAN OF COMMITTEES :— Mr. Cameron elected, 9; Deputy Speaker's Commission to administer the Oath, 17. House informed of Mr. Cameron's absence through illness, 70, 383. Mr. Cameron granted leave of absence on account of serious illness, 397, 424. Mr. Slattery appointed for day only, 70, 342, 344, 348. Deputy reports disorder from Committee of the Whole, 345, 479. Mr. Garrard appointed for day only, 359, 363, 385. Motion made (<i>Sir Henry Parkes</i>) as a matter of urgency to suspend Standing Orders, to allow appointment of, for this day only, 385. Deputies appointed to act temporarily in absence of Chairman, 389. Mr. Speaker calls on Ninian Melville, Esq., to act as Deputy for the day only, 397, 416, 429, 442, 451, 463, 479, 496, 506, 532, 543, 547, 560. Mr. Speaker calls on Jacob Garrard, Esq., to act as Deputy for the day only, 403, 425, 432, 468, 484, 493, 500, 513, 538, 543, 573. Mr. Speaker calls on Thomas Michael Slattery, Esq., to act as Deputy for the day only, 408, 524. Mr. Speaker calls on Albert John Gould, Esq., to act for the day only, 420, 437, 454, 476, 519, 565.		
CHAMBERS, MR. T. W. (See "ADMINISTRATION OF JUSTICE").		
CHANTER, MR. :— A MEMBER FOR THE MURRAY :— Declared guilty of persistent disorder and removed by Sergeant-at-Arms from the Chamber, 220.		
CHAPLAINS :— Information respecting the Church of England, at Rookwood and Waverley Cemeteries, laid on Table, 144	8	1263
CHARGES (See "LUCAS, SURVEYOR").		
CHARITIES (See also "STATISTICS"). Report of the Inspector of Public, for 1886, laid on Table, 52	4	691
"CHELYDRA" S.S. (See "CHINESE.")		

REFERENCES TO THE VOTES AND PROCEEDINGS, VOL. I.—13TH PARLIAMENT—SESSION, 1887-8.	PAPERS.	
	VOL.	PAGE.
C		
CHINESE (See also "ADJOURNMENT"; also "CHINESE RESTRICTION AND REGULATION BILL," 455') :—		
INFLUX OF :—		
Information respecting alleged, from New Caledonia, laid on Table, 174	2	207
Correspondence respecting, laid on Table, 196	2	201
Motion made (<i>Sir Henry Parkes</i>) for Committee of the Whole, 196; House in Committee, and resolution agreed to, 201.		
Motion made (<i>Mr. Thompson</i>) for a Select Committee to inquire into the influx of, their habits, employments, terms on which the Coolie class have immigrated here, and all matters connected therewith, 237; leave given to sit during adjournment and inspect premises, 302.		
Motion made (<i>Mr. Thompson</i>) for return showing number who paid poll-tax and number who exhibited letters of naturalization for 1886 and 1887, 307; Return to Order, laid on Table, 335.	2	209
Petition presented (<i>Mr. Street</i>) Chinese merchants of Sydney in reference to their existing rights, under the Treaty of Peking, read by the Clerk, 519	2	223
IN HER MAJESTY'S COLONIES :—		
Despatch respecting, laid on Table, 344	2	221
IMMIGRATION :—		
Ministerial Statement made by <i>Sir Henry Parkes</i> , 364, 451.		
Further Correspondence respecting, laid on Table, 369	2	203
Petition presented from Chinese residents upon the subject, and read by the Clerk, 454	2	225
Return respecting passengers by steamships "Afghan," "Tsinan," "Guthrie," and "Menmuir," laid on Table, 454	2	211
Motion made (<i>Mr. Dibbs</i>) for adjournment of the House to bring under the notice of the Government the decision of the Supreme Court, and the intention of the Government in regard thereto, in the matter of the illegal detention of certain Chinese, 463.		
Motion made (<i>Mr. Slattery</i>) for adjournment of the House in reference to the remission of £900 of a fine of £1,000 inflicted on the captain of the s.s. "Chelydra" for carrying more than the legal number of Chinese, 525; papers relating to, laid on Table, 538	2	213
Despatch respecting treaty between the Governments of China and the United States on the subject, laid on Table, 529	2	217
VOLE OF CENSURE :—		
Motion made (<i>Mr. Dibbs</i>), condemning the acts of the Government in reference thereto, and amendment moved and negatived, 468.		
CONFERENCE :—		
Correspondence respecting, laid on Table, 479	2	189
Copy of Papers, being telegrams and Draft Bill agreed upon, laid on Table, and read by the Clerk, 520	2	195
Proceedings of, laid on Table, 524	2	171
CHINESE RESTRICTION AND REGULATION BILL :—		
Message from Governor, 454; Standing Orders suspended, House in Committee, Resolution agreed to, presented, read 1°, read 2°; Point of Order, that Bill was beyond order of leave ruled against by <i>Mr. Speaker</i> ; committed, reported with amendments, report adopted, 455; read 3°, passed, and sent to Council, 456; returned with amendments, 514; motion made (<i>Sir Henry Parkes</i>) to consider amendments in Committee, and <i>Mr. Speaker</i> called attention to the nature of one of the amendments, 525; House in Committee, and amendments agreed to, disagreed to, including the amendment in the title, and amended others, 526; message to Council, 531; Council insists on some amendments and does not insist on others, 566; Assembly does not insist on its disagreements, nor on Assembly's amendments to which the Council disagreed, 573; assent reported, 585.	2	227
CHLOROFORM, DEATHS UNDER :—		
Motion made (<i>Mr. Withers</i>) for return of particulars of, 404; Return to Order, laid on Table, 578.	8	1051
CHRISTENSON, REGINA v. (See "ADMINISTRATION OF JUSTICE").		
CHRISTIAN CHAPEL LANDS SALE BILL :—		
Petition presented (<i>Mr. Alfred Allen</i>) for leave to bring in, 168; leave given, presented and read 1°, 174; referred to Select Committee, 185; Report brought up, 224; Order of the Day postponed, 325; read 2°, committed, reported with amendment, Report adopted, 386; read 3°, passed, and sent to Council, 389; returned without amendment, 426; assent reported, 461.	2	883
CHURCH AND SCHOOL LANDS MINING BILL :—		
Motion made (<i>Mr. Inglis</i>) for Committee of the Whole to consider introduction of Bill to make better provision for, 161; House in Committee, resolution agreed to, Message from Governor, 166; presented and read 1°, 573; read 2°, committed, reported with amendments, report adopted, 580; read 3°, passed, and sent to Council, 585; returned with an amendment, 615; amendment agreed to, 627; assent reported, 629.		
CHURCH AND PERKINS STREETS, NEWCASTLE, BILL :—		
Petition presented (<i>Mr. Fletcher</i>) for leave to bring in, 48; leave given, presented and read 1°, 52; referred to Select Committee, 60; Report brought up, 76; read 2°, committed, reported without amendment and report adopted, 107; read 3°, passed, and sent to Council, 112; returned without amendment, 152; assent reported, 171.	2	891
CHURCH OF ENGLAND PROPERTY BILL :—		
Received from Legislative Council, and, on motion of <i>Mr. Abigail</i> , read 1°, 455; Order of the Day postponed, 593; motion made for 2°; <i>Speaker</i> ruled that although it was introduced in the Council as a Private Bill, it should be treated in this House under the 69th Standing Order as a Public Bill; motion for adjournment of Debate moved, and House counted out, 599.		
Petition presented from <i>Captain Rossi</i> , praying to be heard in opposition to the Bill before the Bar of the House or the Select Committee, 538	2	897
Petition presented from <i>Daniel P. M. Halbert, M.A., &c.</i> , against, 560	2	899
CHURCH-STREET, PARRAMATTA (See "PARRAMATTA CHURCH-STREET AMENDED ALIGNMENT BILL").		
CIRCULAR QUAY, PURCHASE OF LAND ADJOINING (See "GOVERNMENT"; also, "PARLIAMENTARY STANDING COMMITTEE ON PUBLIC WORKS").		
CIRCULAR QUAY LAND SALE AND DEDICATION BILL :—		
Message from Governor, 420; motion made (<i>Mr. Burns</i>) for Committee of the Whole, 425; House in Committee, resolution agreed, presented and read 1°, 494; read 2°, committed, 544; reported with amendments, 549; report adopted, 561; read 3°, passed, and sent to Council, 567; returned with an amendment, 613; amendment agreed to, 626; assent reported, 629.	3	1019
CITIES, TOWNS, AND VILLAGES (See "CROWN LANDS").		
CITY OF SYDNEY IMPROVEMENT BOARD :—		
Annual Report of, for year ended August, 1887, laid on Table, 112	2	269
CITY OF SYDNEY MAYORAL ELECTION BILL :—		
Motion made (<i>Mr. O'Connor</i>) for leave to bring in, presented and read 1°, 236; Order of the Day postponed, 349, 508.		

REFERENCES TO THE VOTES AND PROCEEDINGS, VOL. I—13TH PARLIAMENT—SESSION, 1887-8.	PAPERS.	
	VOL.	PAGE.
C		
CIVIL SERVICE (See also "VOTE OF CENSURE") :—		
ACT :—		
Motion made (<i>Mr. Frank Farnell</i>) for a statement showing retirements under clauses 43, 44, 46, and 47, gratuities to officers whose services have been dispensed with under clauses 48, 49, and 50, amount chargeable to Superannuation Account, giving each officer's gratuity, with particulars of all cases where officer's services have been dispensed with, 22; Return to Order, laid on Table, 112.	2	79
Motion made (<i>Mr. Waddell</i>) for alteration of provisions in reference to allowances and gratuities, and by leave withdrawn, 433.		
APPOINTMENTS TO :—		
Return (<i>in part</i>) to Order (<i>Second Session, 1887</i>) laid on Table, 6.	2	85
DEPARTMENT OF PUBLIC WORKS :—		
Information respecting officers in, and Permanent-way men on the Railways, laid on Table, 28.	8	1053
Papers in connection with appointment of Mr. Joseph Barling to the position of Chief Clerk in the Ministerial Branch of, laid on Table, 144.	2	99
APPOINTMENTS MADE IN THE RAILWAY DEPARTMENT :—		
Motion made (<i>Mr. Lyne</i>) for a return showing permanent and temporary since 1st January, 1887, 40; Return to Order, laid on Table, 231.	2	97
SALARIES OF CIVIL SERVANTS :—		
Motion made (<i>Mr. McElhone</i>), that the payment of increases in the salaries proposed by the Stuart Government and sanctioned by Parliament, and continued to the present time, ought to cease, and the salaries revert to the rate paid prior to the granting of the increases, and that effect be given to this resolution in the Estimates for 1888 and negatived, 58.		
EXAMINERS OF TITLES AND REGISTRAR-GENERAL :—		
Particulars respecting the office-hours, &c., of, laid on Table, 63.	2	115
EXAMINERS OF TITLES UNDER REAL PROPERTY ACT :—		
Motion made (<i>Mr. J. P. Abbott</i>) for return showing work done by Mr. Burton and the others, 70; Return to Order, laid on Table, 112.	2	117
GRATUITIES AND RETIRING ALLOWANCES :—		
Motion made (<i>Mr. Frank Farnell</i>) for a comparative return showing amounts voted and paid each year out of Consolidated Revenue Fund for ten years prior to the passing and since the passing of the Act of 1884, 106.		
FEES RECEIVED BY CIVIL SERVANTS :—		
Return (<i>in part</i>) to Order (<i>Second Session, 1887</i>) laid on Table, 191.	2	103
Further Return to Order, laid on Table, 257.	2	109
MR. G. H. EMERY, LATE LAND AGENT AT QUEANBEYAN :—		
Motion made (<i>Mr. O'Sullivan</i>) for all papers, &c., in connection with recent removal of, 215; Return to Order, laid on Table (not printed), 304.		
CHARGES MADE AGAINST EXAMINER OF COAL-FIELDS :—		
Report laid on Table, 273.	8	217
OVERTIME TO OFFICERS :—		
Statement showing amounts in Department of Lands during 1887, laid on Table, 277.	5	97
CORRESPONDENCE, RECORD, AND MAIL BRANCHES, GENERAL POST OFFICE :—		
Return showing names and length of service of Officers employed in, laid on Table, 324.	4	979
MR. LEOPOLD YATES, ACTING STIPENDIARY MAGISTRATE :—		
Information respecting, laid on Table (not printed), 378.		
MESSERS. ADDISON, O'MALLEY CLARKE, AND MR. T. K. ABBOTT, STIPENDIARY MAGISTRATES :—		
Return showing Number and Nature of Complaint against, laid on Table (not printed), 378.		
MR. J. M. BEATTY :—		
Petition from, submitting statement of his public services and praying for consideration of his case, 468.	2	141
BOARD :—		
Annual Report for 1887, laid on Table.	2	69
HARBOURS AND RIVERS DEPARTMENT :—		
Motion made (<i>Mr. Frank Farnell</i>) for a return of officers, their length of service and rate of pay, and the number of articulated pupils and their rates of pay, 500.		
ASSISTANT EXAMINER OF ACCOUNTS, TREASURY :—		
Return respecting applications for position of, laid on Table, 524.	2	111
DEPARTMENT OF PUBLIC INSTRUCTION :—		
Information respecting persons employed in, who have attained the age of sixty years, laid on Table, 635.	4	487
CLARENCE TOWN :—		
CLARENCE, THE (See "ELECTORAL").		
CLARENCE RIVER (See also "PARLIAMENTARY STANDING COMMITTEE ON PUBLIC WORKS") :—		
Report by Sir John Coode on the Entrance to, laid on Table, 475.	3	899
CLARENCE TOWN :—		
REMOVAL OF TIMBER FROM CROWN LANDS :—		
Motion made (<i>Mr. Creer</i>) for papers, 335; Return to Order laid on Table, 385.	5	499
CLARKE, MR. O'MALLEY, STIPENDIARY MAGISTRATE :—		
Return showing number and nature of complaints made against Stipendiary Magistrates, laid on Table, 378.		
CLASSIFICATION OF TEACHERS (See "EDUCATION").		
CLERK OF ASSEMBLY :—		
Reads Proclamation convening Parliament, 1.		
Reads Address in Reply, 3.		
Reads Petition, 76, 84, 88, 127, 145, 218, 246, 252, 294, 303, 345, 352, 421, 437, 454, 492, 496, 505, 519, 543, 565, 579, 635.		
Reads Documents, 520.		
Reads Report from Committee of Elections and Qualifications, 55, 296.		
Reads Deputy Speaker's Commission to administer the Oath of Allegiance, 19.		
Reads letter from Mr. P. J. Hourigan, requesting name of Solicitor who will accept service on behalf of Mr. Speaker, of writ issued at instance of T. M. Slattery, Esq., M.P., 228.		
Reads entry in Votes and Proceedings of Order of Leave for the introduction of a Bill, 246, 349.		
Reads Statement in Speech made by Mr. Haynes, M.P., reported in the <i>Australian Star</i> , 364.		
Summoned to produce records, 89, 351.		
Swears Members of Elections and Qualifications Committee, 37 (1), 287.		
Lays on Table Minutes of Proceedings and Evidence taken before Select Committee of a previous Session, 71, 115, 140.		
Obtains leave to return documents handed in before Select Committee, 88, 468.		

REFERENCES TO THE VOTES AND PROCEEDINGS, VOL. I—13TH PARLIAMENT—SESSION, 1887-8.	PAPERS.	
	VOL.	PAGE.
C		
CLERK OF ASSEMBLY—(<i>continued</i>):—		
Reports non-return to his custody of Records of the House, by a Member who had had the use of them, 51; motion of <i>Privilege</i> moved in reference to—Records returned—and motion by leave withdrawn, 53.		
Retirement of Mr. Jones from position of, 250.		
Commission appointing Mr. Frederick William Webb to be Clerk of the Assembly produced, and Mr. Webb sworn, 285.		
CLOSURE OF DEBATE:—		
Motion made "That Question be now put," and passed, 24 (?), 156, 220, 221, 222, 468, 485.		
Do do do and withdrawn, 156-7.		
Do do do and negated, 493, 530.		
Do do do and Tellers Lists showing less than forty Members in favour of, 468.		
Ruling of Mr. Speaker that when there are no voices for the Noes, and he is satisfied that forty Members are present, it is not necessary to take a Division, 24; dissent from ruling moved (<i>Mr. Dibbs</i>) and negated, 25.		
COAL-FIELDS (See "MINING").		
COAL-FIELDS REGULATION ACT:—		
Correspondence relating to alleged Breaches of, at Duckenfield Colliery, laid on Table, 252	8	343
COAL SUPPLY:—		
GREAT NORTHERN RAILWAY:—		
Motion made (<i>Mr. McElhone</i>) for papers &c. in reference to contracts of Messrs. Reid and Longworth and offer of Mr. Nowland at lower price, 352. Return to Order, laid on Table, 505	6	673
COAST DEFENCES (See "DEFENCES").		
COAST HOSPITAL, LITTLE BAY:—		
Report for 1887 laid on Table, 479	4	599
Report of Board of Health on Treatment of Typhoid Fever at, laid on Table, 608	2	235
COBAR (See "RAILWAYS").		
COCHRAN, CAPTAIN JOHN FOSTER:—		
Motion made (<i>Mr. Neild</i>) for all papers, &c., in reference to estate of the late, 506; Return to Order, laid on Table, 543	8	1065
COCKATOO ISLAND:—		
Correspondence respecting the sanitary condition of, laid on Table, 6	2	243
COINAGE:—		
JUBILEE:—		
Despatch respecting, laid on Table, 5, 356	2	1219, 1221
COLLEGE (See "AGRICULTURAL COLLEGE").		
COLLIERIES (See "MINING").		
COLONIAL CONFERENCE IN LONDON, 1887:—		
Proceedings of,—Vol. 1, laid on Table (not printed), 6.		
Do Vol. 2 (Appendix), Papers laid before the Conference, laid on Table (not printed), 6.		
Proceedings of,—Papers laid before the Conference, laid on Table (not printed), 6.		
COLONY OF AUSTRALIA BILL:—		
Motion made (<i>Sir Henry Parkes</i>) for leave to bring in, 175; presented and read 1 ^o , 176.		
COLONY OF NEW SOUTH WALES:—		
Statistical view of progress of since separation of Queensland in 1859 to 1887, laid on Table, 462...	7	1395
COLO VALLEY RAILWAY SURVEY:—		
Motion made (<i>Mr. Frank Farnell</i>) for papers, &c., 303; Returns (<i>in part</i>) to Order, laid on Table, 348, 352	6	1047, 1067
COMBINATION TRUCKS (See "RAILWAYS").		
COMMERCE AND TRADE (See "STATISTICS").		
COMMISSION (See also "ADELAIDE JUBILEE INTERNATIONAL EXHIBITION").		
Deputy Speaker's (<i>Mr. Cameron</i>) to administer the Oath, 19.		
Appointing Frederick William Webb, Clerk of Assembly, 285.		
INTOXICATING DRINK INQUIRY:—		
Report (<i>First Part</i>), with Minutes of Evidence and Appendices, laid on Table, 6	7	1
APPOINTMENT OF, TO OPEN FOREIGN MARKETS FOR WOOL AND MEAT:—		
Motion made (<i>Mr. Waddell</i>) for, 129, and negated, 130.		
WATER CONSERVATION:—		
Motion made (<i>Dr. Ross</i>) for all correspondence, vouchers, &c., relating to expenditure by the recently expired, 155; Return (<i>in part</i>) to Order, laid on Table, 565	5	829
COMMISSIONS TO PROSECUTE FOR THE CROWN:—		
Motion made (<i>Mr. McElhone</i>) for return showing particulars respecting, 437; Return to Order, laid on Table, 462	2	623
COMMITTEE OF ELECTIONS AND QUALIFICATIONS (See "ELECTORAL").		
COMMON LODGING-HOUSES BILL:—		
Motion made (<i>Mr. Cameron</i>) for Committee of the Whole, 64; Order of the Day postponed, 113; discharged, 325.		
COMMONS:—		
FIELD OF MARS:—		
Return to Order (<i>Second Session of 1887</i>) laid on Table, 103	5	823
MUSWELLBROOK:—		
Motion made (<i>Mr. J. P. Abbott</i>) for papers in reference to dedication of land for, 500.		
COMMONS ACTS:—		
Regulations under, laid on Table, 6	5	825
COMPANIES BILL:—		
Motion made (<i>Mr. J. P. Abbott</i>) for leave to bring in, 378; presented and read 1 ^o , 385; read 2 ^o , committed, reported without amendment, report adopted, 506; read 3 ^o , passed, sent to Council, 512; returned with an amendment, 594; amendment agreed to, 628; Assent reported, 630.		
CONCILIATION (See "TRADES CONCILIATION BILL").		
CONDITIONAL PURCHASES (See "CROWN LANDS"; also "MINING"; also "CONVERSION TO MINING CONDITIONAL PURCHASES VALIDATING BILL"; also "CROWN LANDS PURCHASES VALIDATION BILL").		
CONDOLENCE (See "ADDRESS").		
CONFERENCE (See "POSTAL"; also "CHINESE").		
CONNOLLY, MR. J. F.:—		
APPLICATION TO MINE IN PARISH OF CURRAJONG:—		
Motion made (<i>Mr Stokes</i>) for all correspondence in reference to, between 1884 and 1887, 118; Return to Order, laid on Table, 294	8	349

REFERENCES TO THE VOTES AND PROCEEDINGS, VOL. I—13TH PARLIAMENT—SESSION, 1887-8.	PAPERS.	
	VOL.	PAGE.
C		
CONSERVATION OF WATER :—		
LAKE CUDGELLICO AND THE LOWER LACHLAN RIVER :—		
Motion made (<i>Mr. Gormly</i>) for Construction of Works, 560.		
COMMISSION :—		
Motion made (<i>Dr. Ross</i>) for all correspondence, vouchers, &c., relating to expenditure by, 155;		
Return (<i>in part</i>) to Order, laid on Table, 565	5	829
CONSOLIDATED REVENUE (See also "FINANCE").		
Statement of the Fund for 1888, laid on Table, 219	3	497
CONSOLIDATED REVENUE FUND BILL :—		
Motion made (<i>Mr. Burns</i>) that suspension of certain Standing Orders is of urgent and pressing necessity; Standing Orders suspended; Messages from Governor, 241; ordered, presented, read 1 ^o , 2 ^o , committed, reported without amendment, report adopted, read 3 ^o , passed and sent to Council, 242; returned without amendment, 247; Assent reported, 250.	3	821-823
CONSOLIDATED REVENUE FUND BILL (No. 2) :—		
Message (Vote of Credit), 285; Standing Orders suspended, ordered, presented, and read 1, 295; read 2 ^o , committed, reported without amendment, report adopted, read 3 ^o , passed and sent to Council, 296; returned without amendment, 309; Assent reported, 311.	3	825
CONSOLIDATED REVENUE FUND BILL (No. 3) :—		
Motion made (<i>Mr. Burns</i>) for suspension of Standing Orders, 344; Message from Governor 345; ordered, presented, and read 1 ^o , 2 ^o , committed, reported without amendment, report adopted, read 3 ^o , passed and sent to Council, 346; returned without amendment, 349; Assent reported 351.	3	827
CONSOLIDATED REVENUE FUND BILL (No. 4) :—		
Message (Vote of Credit), 404; Standing Orders suspended, ordered, presented, and read 1 ^o , 2 ^o committed, reported without amendment, report adopted, read 3 ^o , passed and sent to Council, 409; returned without amendment, 416; Assent reported, 419.	3	829
CONSOLIDATED REVENUE FUND BILL (No. 5) :—		
Message (Vote of Credit) 477; Standing Orders suspended, 479; ordered, presented, read 1 ^o , 2 ^o , committed, reported without amendment, report adopted, read 3 ^o , passed and sent to Council, 481; returned without amendment, 486; Assent reported, 491.	3	831
CONSOLIDATED REVENUE FUND BILL (No. 6) :—		
Motion made (<i>Mr. Burns</i>) for suspension of Standing Orders, Message from Governor, 553; ordered, presented, read 1 ^o , 2 ^o ; committed, reported without amendment, report adopted, read 3 ^o , passed and sent to Council, returned without amendment, 554; Assent reported, 555.	3	833
CONSTITUTION ACT AMENDMENT (See "MINISTERIAL ELECTION BILL").		
CONTAGIOUS DISEASES PREVENTION BILL :—		
Motion made (<i>Mr. Frank Farnell</i>) for Committee of the Whole, 64; Order of the Day postponed, 107, 145, Discharged; 252.		
CONTEMPT :—		
Motion made adjudging a member guilty of, 156 (?).		
CONTRACTORS (See "RAILWAYS").		
CONTRACTORS DEBTS ACT EXTENSION BILL :—		
Motion made (<i>Mr. Carruthers</i>) for Committee of the Whole, 52; Order of the Day postponed, 65, 107, 131, 288; House in Committee; resolution agreed to, 321; presented and read 1 ^o 342; Order of the Day postponed, 416; read 2 ^o , committed, reported without amendment, report adopted, 507; read 3 ^o , passed and sent to Council, 513; returned without amendment, 547; Assent reported, 555.		
CONTRACTS FOR LOCOMOTIVES (See "RAILWAYS").		
CONTRACTS OF CHARLES KIDMAN AND SONS AND JAMES KIDMAN :—		
Statement of Amount of Money paid under, from 1876 to 1887, laid on Table (not printed), 403		
CONVERSION INTO MINING CONDITIONAL PURCHASES VALIDATION BILL :—		
Motion made (<i>Mr. Garrett</i>) for leave to bring in, 231; presented and read 1 ^o , 236; read 2 ^o , committed, reported with amendments, report adopted, 258; read 3 ^o , passed, and sent to Council, 263; returned with an amendment, 281; amendment agreed to, 309; Assent reported, 317.		
CONVEYANCERS (See "ATTORNEYS BILLS OF COSTS AND PRACTICE OF CONVEYANCING AMENDMENT BILL").		
CONVICTIONS UNDER THE LICENSING ACT :—		
Motion made (<i>Mr. Henson</i>) for additional information respecting, 506.		
SPIRITS, WINES, AND BEER :—		
Annual Return to Order laid on Table, 560	7	681
CONWAY, C. J. :—		
CLAIM OF :—		
Motion made (<i>Mr. Waddell</i>) for Select Committee to inquire into and report upon, and withdrawn, 237.		
COODE, SIR JOHN, K.C.M.G., M.I.C.E. :—		
Report (with plans) upon Lake Macquarie Harbour Works, laid on Table, 324	3	895
Report on Entrance to Richmond River, laid on Table, 462	3	905
Report on the Entrance to Clarence River, laid on Table, 475	3	899
COOLA CREEK (See "EDUCATION").		
COOLE, TICKET-COLLECTOR EDWARD (See "RAILWAYS").		
COOMA (See "ROADS"; also "RAILWAYS").		
COOMA CHURCH OF ENGLAND LANDS SALE BILL :—		
Petition presented (<i>Mr. Day</i>) for leave to bring in, 523; leave given; presented and read 1 ^o , 529; referred to Select Committee, 537; Report brought up, 547; Order of the Day postponed, 585; read 2 ^o , committed, reported with amendments, report adopted, 599; read 3 ^o , passed, and sent to Council, 602; returned with amendments, 639; amendments agreed to, 641; assented to in Council Chamber, 642.	2	901
COOMBING (See "RAILWAYS").		
COPELAND ATS. NASH (See "RAILWAYS").		
COPYRIGHT LAWS OF GREAT BRITAIN :—		
Correspondence respecting infringement of, laid on Table, 181	8	1047
CORK, ROBERT, CASE OF (See "CROWN LANDS PURCHASES VALIDATION BILL").		
CORKERY, DANIEL (See "RAILWAYS").		
COROWA :—		
LATE ACTING POLICE MAGISTRATE :—		
Return to Order (<i>Second Session</i> 1887) laid on Table (not printed), 144.		
Further Return to Order (<i>Second Session</i> 1887) laid on Table, 389; Ordered to be printed, 454...	2	631
CORPORATION ACT AMENDMENT BILL (See "SYDNEY CORPORATION ACT AMENDMENT BILL").		

REFERENCES TO THE VOTES AND PROCEEDINGS, VOL. I—13TH PARLIAMENT—SESSION, 1887—8.	PAPERS.	
	VOL.	PAGE.
C		
CORPORATION OF THE CITY OF SYDNEY :— Statement of Receipts and Expenditure for 1885, 1886, and 1887 respectively, laid on Table, 429...	2	255
CORRESPONDENCE (See "POSTAL") :—		
COUNCIL (See "LEGISLATIVE COUNCIL").		
COUNSEL'S FEES (See "ATTORNEY-GENERAL").		
COUNTRY-OUT (See "NO QUORUM").		
COUNTRY TOWNS WATER AND SEWERAGE ACT (See also "BY-LAWS"), :— NOTIFICATIONS UNDER, LAID UPON THE TABLE :—		
Authorizing the construction of Water Supply Works for the town of Balranald, 6	5	881
Completion of the Water Supply Works for the town of Wentworth, 475	5	885
Completion of the Water Supply Works for the town of Bourke, 475	5	883
COUNTRY TOWNS WATER AND SEWERAGE ACT EXTENSION BILL :— Motion made (<i>Sir Henry Parkes</i>) for Committee of the Whole, 64; House in Committee, Resolution agreed to, presented and read 1 ^o , 70; read 2 ^o , committed, reported without amendment, and report adopted, 104; read 3 ^o , passed, and sent to Council, 112; returned without amendment, 177; assent reported, 219.		
COWRA (See "RAILWAYS").		
COYLE, ROBERT :— Motion made (<i>Mr. Walker</i>) for Select Committee to inquire into treatment of, whilst a prisoner in Berrima and other gaols, and debate interrupted by Government Business, 123; Order of the Day postponed, 131; Order of the Day discharged, 252.		
CRAWFORD, RAILWAY TRAFFIC INSPECTOR (See "RAILWAYS").		
CREDITORS REMEDIES (See "JUDGMENT CREDITORS REMEDIES EXTENSION BILL")		
CREER, MR. A MEMBER FOR NORTHUMBERLAND :— Declared guilty of persistent disorder and removed, by the Sergeant-at-Arms, from the Chamber, 221.		
CREMATION BILL :— Motion made (<i>Mr. Trickett</i>) for Committee of the Whole, 53; Order of the Day discharged, 77. Motion made (<i>Mr. Trickett</i>) for leave to bring in, presented and read 1 ^o , 185. Petition in favour of, from David Buchanan, Barrister-at-Law, presented, 272	8	1049
CRICKET GROUND (See "ASSOCIATION CRICKET GROUND").		
CRIME AND CIVIL JUSTICE (See "STATISTICS").		
CRIMINALS (See "FUGITIVE CRIMINALS").		
CRIMINAL LAW AMENDMENT BILL :— Received from Legislative Council, and on motion of (<i>Mr. William Clarke</i>) read 1 ^o , 430; read 2 ^o , committed, reported without amendment, report adopted, 596; read 3 ^o , passed, returned to Council, 598; Assent reported, 626.		
CROWN LANDS (See also "CROWN LANDS PURCHASES VALIDATION BILL"; also "CROWN LANDS BILL"; also "RESERVES") :— ALTERATIONS OF DESIGNS OF CITIES, TOWNS, AND VILLAGES :— Abstract of, laid on Table, 5, 97, 150, 210, 263, 326, 360, 442, 547, 634	5	629 to 647
SITES FOR CITIES, TOWNS, AND VILLAGES :— Abstract of, laid on Table, 5, 97, 150, 210, 263, 326, 360, 442, 484, 547, 634	5	743 to 763
RESERVED FOR PRESERVATION OF WATER SUPPLY :— Abstract of, laid on Table, 5, 97, 151, 209, 263, 326, 360, 442, 484, 547, 634	5	701 to 741
DEDICATED TO PUBLIC PURPOSES :— Abstract of, laid on Table, 5, 97, 112, 151, 209, 263, 326, 360, 442, 484, 547, 634	5	649 to 671
DEDICATED TO RELIGIOUS PURPOSES :— Abstract of, laid on Table, 5	5	673
DEDICATION OF CERTAIN LANDS UNDER 105 SEC. :— Gazette Notices respecting, laid on Table, 5, 97, 210, 326, 344, 360, 441, 484, 547, 634	5	675 to 699
REGULATIONS :— Under Act of 1884, laid on Table, 40 (?), 155, 199, 267, 302, 360, 429, 613 ..	5	581 to 597
Under Act of 1884, notifications of cancellation, laid on Table, 360	5	595
DEPARTMENT :— Report for 1886 laid on table, 257	5	1
Statement showing overtime to officers for 1887, laid on Table, 277	5	97
VOLUNTEER LAND ORDERS :— Motion made (<i>Mr. Crouch</i>) for a return showing number issued, number made use of, specifying the number used in each Land District, 12; Return to Order, laid on Table, 168	2	31
RENTS ON CROWN LEASES :— Motion made (<i>Mr. Lee</i>) for a return showing rents recommended by Local Land Boards on each pastoral, homestead, and conditional lease, and occupation license, the minimum rental on same, and rental fixed by Minister, 22; Return (<i>in part</i>) to Order, laid on Table, 84	5	171
ALBURY AND WAGGA WAGGA OFFICES :— Motion made (<i>Mr. Day</i>) for all papers, reports, &c., sent in by the Board appointed to inquire into the working of, 23.		
ALBURY TO WAGGA WAGGA, REMOVAL OF SURVEY OFFICES FROM :— Motion made (<i>Mr. Day</i>) for all papers, reports, telegrams, and recommendations respecting, 41; Return to Order, laid on Table, 476	5	101
EVAN MCINTOSH'S CONDITIONAL PURCHASE AT CURRABUBULA :— Motion made (<i>Mr. Levien</i>) for a Select Committee on, which was afterwards transferred to Daniel Regan, Esq., and that evidence and papers produced before the Select Committee in Session 1885-6 be referred, 36.		
GRAFTON AND THE CLARENCE ELECTORATES :— Motion made (<i>Mr. See</i>) for a return showing entire revenue from all sources since 1861, 128.		
MRS. ANN ROUSE'S CONDITIONAL PURCHASE AT KAHIBAH :— Motion made (<i>Mr. J. P. Abbott</i>) for all papers relating to 80 acres made at Newcastle on 20th July, 1871, also on 4th February, 1875, and all reports on and surveys of the land, with plans and descriptions of any reserves by which the said 80 acres of land was affected, 41; Return to Order, laid on Table, 208; referred to Select Committee, 389	5	277
Motion made (<i>Mr. J. P. Abbott</i>) for Select Committee to inquire into circumstances of, 89; papers referred to Committee, 389; report brought up, 496	5	265
CURRAGUNDI RUN :— Motion made (<i>Mr. Frank Farnell</i>) for all papers, plans, &c., in connection with the pastoral holding of, Gwydir District, 48; Return to Order, laid on Table, 208	5	251
Petition of Mr. George Robert Edward Fergusson, that he entered into possession of a conditional purchase, and an action was brought against him by Mr. G. M. Pitt, by which he incurred serious expense and losses, and praying relief, presented, 277	5	263

REFERENCES TO THE VOTES AND PROCEEDINGS, VOL. I—13TH PARLIAMENT—SESSION, 1887-8.	PAPERS.	
	VOL.	PAGE.
C		
CROWN LANDS—(continued) :—		
G. M. PITT'S, JUNR.—BUNABA NORTH AND CURRAGUNDI STATIONS :—		
Petition from George Matcham Pitt, junior, that in 1834 on the passing of the present Act he was the owner of, and that by the division of the said stations injustice has been done him, and he has suffered pecuniary loss, and praying relief, presented, 144; motion made (<i>Mr. Bowman</i>), for Select Committee, 232; report brought up, 416	5	485
	5	469
THOMAS THOMPSON'S CONDITIONAL PURCHASE, MADE AT MOAMA :—		
Motion made (<i>Mr. Chanter</i>) that a Select Committee be appointed, and that Progress Report, evidence, &c., of last Session be referred, 53; Report brought up, 200; adoption of Report negated, 433	5	207
SALE OF CERTAIN LAND, PARISH OF MOLONG, COUNTY OF ASHBURNHAM :—		
Motion made (<i>Dr. Ross</i>) for Address to Governor, for copies of correspondence, plans, &c., and the Judge's decision and ruling, 479.		
JOHN TIERNEY'S CONDITIONAL PURCHASE :—		
Motion made (<i>Mr. Wall</i>) for Select Committee to inquire into refusal by Mines Department of the application to mine on, under the 7th section of the Act, 59.		
WILLIAM SKENE'S PRE-LEASE AT CONARGO :—		
Motion made (<i>Mr. Chanter</i>) for all papers, correspondence, &c., in relation to, 60, 320; Return to Order, laid on Table, 208; Return to Order, laid on Table, 634.....	5	217, 233
RINGBARKING :—		
Motion made (<i>Dr. Ross</i>) for Return showing area and list of runs on which permission had been granted since 31st March, 1881, 325; Return to Order, laid on Table, 613	5	507
CONDITIONAL PURCHASES OF JAMES C. STEVENSON :—		
Motion made (<i>Mr. J. P. Abbott</i>) for copies of all papers relating to, 325; Return to Order, laid on Table, 432	5	325
REMOVAL OF TIMBER FROM, NEAR CLARENCETOWN :—		
Motion made (<i>Mr. Creer</i>), for papers, 335; Return to Order, laid on Table, 385	5	499
CONDITIONAL PURCHASE OF ZACHARY BENN :—		
Motion made (<i>Mr. Crouch</i>) for papers in the case of, 341; Return to Order, laid on Table, 429.....	5	311
CONDITIONAL PURCHASE CASE—GEORGE MILLGATE v. The Honorable JOHN SMITH :—		
Motion made (<i>Dr. Ross</i>) for further correspondence, reports &c., since that laid on Table in March, 1884, 64; Further Return to Order, laid on Table, 277.....	5	343
THE LAND LAWS :—		
Petition referring to present mode of determining the rents of pastoral leases, presented, 76	5	619
Petition referring to operation of, and praying that certain amendments be made in Bill now before House, presented, 88, 218, 294.....	5	621 to 625
Petition referring to action of Minister for Lands in fixing rents, and stating that the raising of the rents had depreciated the value of pastoral securities, presented, 352.....	5	627
FORFEITED CONDITIONAL PURCHASES WITHIN LEASEHOLD AREAS :—		
Motion made (<i>Mr. J. P. Abbott</i>), for Address to the Governor. That as the Privy Council had in the case <i>Edols v. Tearle</i> affirmed that the land was open to conditional purchase, this House is of opinion that such should at once be thrown open for conditional purchase, 353.		
SELECTIONS BY JOHN HARRISON, OF LISMORE :—		
Motion made (<i>Mr. Ewing</i>), for papers in reference to forfeiture of, 357; Return to Order, laid on Table, 462.....	5	447
CLAIM OF CORNELIUS GRADY :—		
Leave given to Clerk to return to Lands Department papers produced before the Select Committee of last Session on the subject, 88.		
PARRY'S CONDITIONAL PURCHASES ON CURRUGUNDI AND WARREN SOUTH RUNS :—		
Motion made (<i>Mr. Hassall</i>) for a Select Committee to inquire into, 130; Report brought up, 487...	5	239
SECTION 4, CROWN LANDS ALIENATION ACT OF 1861 :—		
Opinion of Mr. Attorney-General Dalley respecting the application of, to the reservation of large areas from sale for mining purposes, laid on Table, 500	5	109
CONDITIONAL PURCHASES MADE BY MR. AND MRS. POOLE, MESSRS PARNELL, AND THE MISSES PARNELL :—		
Motion made (<i>Mr. McElhone</i>) for papers in connection with, 500; Return to Order, laid on Table, 634.....	5	355
COMMON FOR MUSWELLBROOK :—		
Motion made (<i>Mr. J. P. Abbott</i>) for papers relating to dedication, 500.		
CONDITIONAL PURCHASE MADE BY MARY MALONEY AT BURROWA :—		
Motion made (<i>Mr. Vaughn</i>) for papers in connection with, 546.		
SELECTION MADE BY GEORGE FOSTER AT COROWA :—		
Motion made (<i>Mr. J. P. Abbott</i>) for papers in connection with, 546.		
QUIT RENTS :—		
Return to Order (Session 1887), laid on Table, 559	5	195
FENCING PROVISIONS OF THE LAND LAW :—		
Adjournment moved to call attention to necessity of immediate legislation in regard to, 595.		
ROBERT MACKRELL'S CONDITIONAL PURCHASE AT FORBES :—		
Motion made (<i>Mr. Vaughn</i>) for a Select Committee to inquire into, and that Proceedings and Evidence of previous Session, laid on Table to be referred, 130; Proceedings, &c., laid on Table and referred to Select Committee, 140. Report brought up, 342	5	285
Petition from E. H. Moulder of Wardry Station, that he is interested in, and praying to be heard by Counsel or Agent before the Select Committee, presented, and prayer of Petitioner granted, 181.....	5	309
JOACHIM FAMILY :—		
Petition from, that they came to Colony in 1873, and conditionally purchased land near Moama, that on alleged grounds of non-residence and others, they were subjected to severe litigation, and that their title has not been recognised by the Crown, presented, and referred to Select Committee on Crown Lands Purchases Validation Bill, 135	5	559
Papers (Session 1873-4) in reference to Conditional Purchases of, referred to Select Committee on Crown Lands Purchases Validation Bill, 161.		
MEASURED FOR SALE AT FITZROY WATERFALL :—		
Plan of forty-five portions, situate near the village of Yarrunga, laid on Table, 228	5	201
ROBERT MUNFORD'S CONDITIONAL PURCHASES MADE AT MOLONG :—		
Motion made (<i>Dr. Ross</i>) for a Select Committee to inquire into and report upon, 237.		
Motion made (<i>Dr. Ross</i>) to refer Return to Order (Session 1887), 277.		
MR. G. H. EMERY, LATE LAND AGENT AT QUEANBEYAN :—		
Motion made (<i>Mr. O'Sullivan</i>) for all papers, &c., in connection with the recent removal of, 215; Return to Order laid on Table (not printed), 304		
CONDITIONAL PURCHASES :—		
Motion made (<i>Dr. Ross</i>) for a return showing the number made in each District from 1881 to date, the total area, and the number transferred, 150, 416; Return to Order, laid on Table, 429.....	5	199

REFERENCES TO THE VOTES AND PROCEEDINGS, VOL. 1, 13TH PARLIAMENT—SESSION, 1887-8.	PAPERS.	
	VOL.	PAGE.
C		
CROWN LANDS—(continued):—		
CLAIM OF ISAAC BARCLAY:—		
Motion made (<i>Mr. Martin</i>) for a Select Committee to consider, for compensation for losses sustained in defending his title to land held under Crown Grant, 165. Report brought up, 609.	5	487
ADMINISTRATION OF LAND LAWS BY MINISTER FOR LANDS:—		
Motion made (<i>Mr. Stokes</i>) that this House do now adjourn, to call attention to unsatisfactory, put and negatived, 263.		
CLAIM OF CHARLES STEVENS:—		
Report from Select Committee (<i>Session 1887</i>), adopted, 268.		
RENTS FOR CROWN LANDS:—		
Motion made (<i>Mr. O'Sullivan</i>) for a return of rent received for leasehold areas, occupation licenses, and homestead areas, under Land Act of 1884, 258. Return to Order, laid on Table, 320	5	111
TABLE V. EDOLS:—		
Motion made (<i>Mr. J. P. Abbott</i>) for adjournment of the House to discuss decision of the Privy Council, 287.		
RENTS OF PASTORAL LEASES:—		
Return giving particulars of appeals in connection with, not dealt with by Minister, laid on Table, 415	5	191
SELECTION OF JAMES IRVING, SOUTH YATHONG, URANA:—		
Motion made (<i>Mr. Lyne</i>) for papers in connection with, 403.		
RATE OF RENTAL PER ACRE AND LICENSE FEE PER SECTION ON THE WESTERN DIVISION:—		
Return respecting, laid on Table, 408; Return (<i>in substitution</i>), 415	5	113
IMPROVEMENTS EFFECTED ON, IN EASTERN, CENTRAL, AND WESTERN DIVISIONS:—		
Return showing value of, laid on Table, 415	5	205
AREA OF LAND ALIENATED, LEASED, AND RETAINED IN EASTERN DIVISION:—		
Approximate return showing, laid on Table, 415	5	203
RENTS AND LICENSE FEES:—		
Return respecting, recommended by Land Boards and fixed by Minister, 415	5	123
LAND BUSINESS, DISTRICTS OF PARKES, FORBES, AND MOLONG:—		
Return respecting, for years 1885, 1886, and 1887, respectively, laid on Table, 580	5	197
REFUND OF ABATEMENTS IN RENTS OF CROWN LESSEES:—		
Adjournment of the House moved in respect to cases where appeal has been made and rent reduced, 586.		
CROWN LANDS ACT FURTHER AMENDMENT BILL (FENCING):—		
Motion made (<i>Mr. Garrett</i>), for Committee of the Whole, 573; Standing Orders suspended, 578; House in Committee, resolution agreed to, 580; presented (<i>Sir Henry Parkes</i>), read 1 ^o , 586; read 2 ^o , passed, committed, reported, report adopted, 587; 3 ^o reading moved, and amendment proposed to recommit, and negatived, read 3 ^o , passed, motion made for Message to Council, and amendment moved to add words, and negatived, Message to Council passed, 595; returned without amendment, 626; Assent reported, 630.		
CROWN LANDS ALIENATION ACT OF 1861 (See "CROWN LANDS").		
CROWN LANDS ACT OF 1884 (See "CROWN LANDS").		
CROWN LANDS BILL:—		
Motion made (<i>Mr. Garrett</i>) for Committee of the Whole, 35; House in Committee, Resolution agreed to, Message from Governor, 49; presented and read 1 ^o , 65; motion made for 2 ^o and debate adjourned, 99; Order of the Day discharged, and Bill withdrawn, 137	5	599
PETITION PRESENTED:—		
Suggesting certain amendments, 123	5	601
CROWN LANDS BILL (No. 2):—		
Motion made (<i>Mr. Garrett</i>) for Committee of the Whole, 152; House in Committee, 161; Resolution agreed to, Message from Governor, 162; presented and read 1 ^o , 162; motion made for 2 ^o , and debate adjourned, 296, debate resumed, and further adjourned, 308, 315, 326, 335, 338, 349, 357; resumed, read 2 ^o , 361; committed, 362; further considered in Committee, 373, 374, 381, 390, 398, 417, 437, 442.	5	603
PETITION FROM WILLIAM JAMES REID AND THOMAS SHAW:—		
Praying that the 101st clause may be amended, and asking for leave to appear at Bar of the House, presented, 303; and prayer granted, 404	5	607
PETITION OF INHABITANTS OF MOAMA AND SURROUNDING DISTRICTS:—		
Protesting against the Bill and praying that a Bill will be passed enabling the petitioners to obtain portions of land on which to settle, read by the Clerk, 437	5	605
PETITION FROM THE MUNICIPAL COUNCIL OF THE BOROUGH OF ST. LEONARDS:—		
Praying that clauses 84 to 87 be eliminated or amended in the manner indicated, 462	5	609
PETITION SELECTORS OF ADAMINABY AND DISTRICT:—		
Praying the House to consider certain amendments suggested by them, 500	5	611
PETITION OF MUNICIPAL COUNCIL OF MANLY:—		
Praying that clauses 84 to 87 may be eliminated or amended as indicated in the Petition, 505	5	615
PETITION OF RESIDENTS OF THE DISTRICT OF BOGGABRI:—		
Praying that a Court of Appeal should be established, and stating that the present and proposed Courts of Inquiry does not meet with approval, 505	5	613
PETITION OF MAYOR OF BOROUGH OF WEST MAITLAND:—		
Praying the House not to pass the clauses relating to the rescinding reservations of water frontages, 543	5	617
CROWN LANDS PURCHASES VALIDATION BILL:—		
Motion made (<i>Mr. Garrett</i>) for leave to bring in, presented and read 1 ^o , 17; motion made for 2 ^o — amendment carried to refer Bill to a Select Committee, 29; report brought up, 468; motion made for 2 ^o (<i>as amended and agreed to in Select Committee</i>) and debate adjourned, 494; read 2 ^o , committed, reported with amendments, 544; recommitted, 547; reported with a further amendment, 548; read 3 ^o , passed, and sent to Council, 560; returned with an amendment 594; Order of the Day postponed, 609; Council's amendment agreed to, 627; Assent reported 630.	5	500
PETITIONS REFERRED TO SELECT COMMITTEE:—		
From the Joachim family, 135	5	563
Martin Tully, the younger, 161		
Robert Barclay Wallace and James Robert Miller Robertson, 165.	5	561
Matthew O'Shanassy, 208.	5	565
Alexander Rodgers, 215.	5	567
John Allen, 232.	5	569
Edward Grace, 324.	5	573
Stephen Fennell, 328.	5	571
Mary Elizabeth Murphy, 403.	5	575
Patrick Hogan of Randwick, 451.	5	579

REFERENCES TO THE VOTES AND PROCEEDINGS, VOL. I—13TH PARLIAMENT—SESSION, 1887-8.	PAPERS.	
	VOL.	PAGE.
C		
CROWN LANDS PURCHASES VALIDATION BILL—(continued) :—		
SELECT COMMITTEE :—		
Motion made (<i>Mr. Garrett</i>) that the recommendation of the Minister for the validation of certain conditional purchases be referred to the Select Committee on the Bill, 442.		
Applications for validation of Conditional Purchases, referred to Select Committee, 136.		
Papers in reference to Conditional Purchases of the Joachim Family, referred to the Select Committee, 161.		
Motion made (<i>Mr. Garrett</i>) that the applications or recommendations for the validation of the auction purchases enumerated therein be referred to the Select Committee sitting on the Bill, 397.		
Motion made (<i>Mr. Garrett</i>) that the applications or recommendations for the validation of the conditional purchases enumerated therein be referred to Select Committee sitting on the Bill, 397.		
Name of Mr. Thompson added to, 230.		
CASE OF ROBERT CORK AT MILTON :—		
Papers laid on Table, and referred to Select Committee, 403 ; leave given to clerk to return papers, 468.		
SELECTION OF MICHAEL HERREN :—		
Petition presented (<i>Mr. Levien</i>) praying that the case may be referred to the Select Committee, 408.	5	577
CUDGELICO LAKE. (See "CONSERVATION OF WATER").		
CURRAGUNDI RUN (See "CROWN LANDS").		
CUSTOMS :—		
Petition from residents of Broughton Creek, Brogher's Creek, Broughton Vale, and Kangaroo Vale, against the abolition of duties on Farm Produce, presented, 252.	3	881
MR. SWIFT, CUSTOM HOUSE OFFICER, BREWARRINA :—		
Motion made (<i>Mr. Waddell</i>) for papers in connection with dismissal of, 369 ; Return to Order laid on Table, 370	2	133
CUSTOMS REGULATION ACT OF 1879 AND CUSTOMS DUTIES ACT OF 1887 :—		
Amended Regulations under, laid on Table, 203	3	865
D		
DAILY "HANSARD" (See "HANSARD").		
DAMS AND WEIRS REGULATION AND REGISTRATION BILL :—		
Motion made (<i>Mr. J. P. Abbott</i>) for leave to bring in, 378 ; presented and read 1 ^o , 381 ; Order of the Day discharged and Bill withdrawn, 506.		
DARLING RIVER (See "BRIDGES").		
DAWES POINT (See "LAND").		
DAYS DALE TANK :—		
Notification of resumption under Lands for Public Purposes Acquisition Act, of land in Parish of Gordon, County of Hume, laid on Table, 415	8	951
DEAN, MR. THOMAS (See "EDUCATION").		
DEATH OF HONORABLE MEMBER OF THE LEGISLATIVE ASSEMBLY (See "GIBBES, FREDERICK JAMISON, ESQ.")		
DEATHS UNDER CHLOROFORM :—		
Motion made (<i>Mr. Withers</i>) for Return of particulars respecting, 404 ; Return to Order laid on Table, 578.	8	1051
DEBATE (See "ADJOURNMENT").		
DEDICATION OF CERTAIN LANDS (See "CROWN LANDS").		
DEDUCTIONS FROM WAGES OF EMPLOYEES FOR MEDICAL ATTENDANCE :—		
Motion made (<i>Mr. Walker</i>) for Select Committee to inquire into practice of contractors, 353 ; Return to Order, "Patients received into Hospitals from Public Works," referred to Committee, 462.		
DEFENCES :—		
Report of Major-General Schaw on, of New South Wales, laid on Table, 199	2	47
COAST AND HARBOUR :—		
Correspondence respecting Major Parrott's report on, laid on Table, 84	2	63
DEFICIT ACCOUNT (See "FINANCE").		
DENILQUIN :—		
FIRE BRIGADES BOARD :—		
Report for 1887-8, laid on Table, 432.	2	605
Regulations laid on Table, 634	2	607
DENILQUIN TRAMWAY BILL (See "HAY AND DENILQUIN TRAMWAY BILL").		
DEPUTY CHAIRMAN OF COMMITTEES (See "CHAIRMAN OF COMMITTEES").		
DEPUTY SPEAKER :—		
Commission to Angus Cameron, Esquire, to administer the Oath of Allegiance to Members, reported, read by Clerk, 19.		
Takes Chair, 579.		
DESPATCHES :—		
LAI D ON TABLE :—		
Jubilee Coinage, 5, 356	8	1219, 1221
Foreign Deserter's Act, 1852, 135, 356	8	1181, 1183
Surrender of Fugitive Criminals, 285	8	1281
Trade in Wheat between Australia and Barcelona, 335, 475	8	1309, 1311
Divorce Extension Bill of 1887, 344	8	1061
Position of Chinese in Her Majesty's Dominions, 344	2	221
Authentication of Extradition Papers, 352	8	1067
Applications for certificates of competency as masters and mates, 475	8	1015
Employment of officers of the Royal Navy under Colonial Governments, 475	2	23
Treaty between China and the United States in reference to Chinese Immigration, 523	2	217
DESTRUCTION OF RABBITS (See "RABBIT PEST").		
DEVONSHIRE-STREET (See "CEMETERY").		
DIAMOND DRILLS (See "MINING").		

REFERENCES TO THE VOTES AND PROCEEDINGS, VOL. I—13TH PARLIAMENT—SESSION, 1887-8.	PAPERS.	
	VOL.	PAGE.
D		
DIBBS, Mr. :—		
A MEMBER FOR THE MURRUMBIDGEE :—		
Declared guilty of persistent disorder and removed by Sergeant at Arms from the Chamber, 221.		
PRIVILEGE—GARRETT V. DIBBS :—		
Motion made (<i>Mr. Dibbs</i>) That the Crown Solicitor be instructed to defend the action of <i>Garrett v. Dibbs</i> in the interest of the Privileges of this House, 326.		
DIFFERENTIAL RATES (See "RAILWAYS").		
DISCOVERY OF GOLD (See "MINING").		
DISEASES (See "VINE DISEASES ACT AMENDMENT BILL").		
DISEASED ANIMALS AND MEAT BILL :—		
Motion made (<i>Sir Henry Parkes</i>) for Committee of the Whole, 537; Message from Governor, 539; House in Committee, 543; resolution agreed to, presented, and read 1 ^o , 544; motion made for 2 ^o , and debate adjourned, 547; Order of the Day postponed, 566; read 2 ^o , committed, 609; Order of the Day postponed, 627.	8	667
DISEASES IN SHEEP AND IMPORTED STOCK ACTS :—		
Regulations under, laid on Table, 257	8	651
DISORDER :—		
Language used reflecting on the Chief Commissioner of Insolvent Estates, now an acting Judge of the Supreme Court, ruled out of order—motion moved to dissent from Mr. Speaker's ruling and afterwards withdrawn, 49.		
In division—the Honorable Member for Northumberland, Mr. Walker, "named"—motion moved, adjudging him guilty of contempt—bars opened and division lapsed—the Honorable Member for South Sydney, Mr. Toohey, "named," motion made adjudging him guilty of contempt and committing him to the custody of Sergeant-at-Arms, and Speaker having ruled that the motion was in order, motion made to dissent from ruling, 156; and negatived, and Mr. Toohey, having apologized, motion of contempt withdrawn, 157.		
Use of Language by Mr. Melville, one of the Members for Northumberland, not having been apologized for, when called upon by the Chair, Mr. Melville "named"—Mr. Melville withdrew words and apologized, 184.		
Members declared guilty of persistent disorder, and removed from the Chamber by the Sergeant-at-Arms, 220 (?), 221 (?).		
In Committee—Deputy Chairman reported that the Honorable Member for Newcastle had crossed the Chamber and committed an assault on the Honorable Member for Mudgee, Mr. Haynes. Mr. Fletcher removed from Chamber by Sergeant-at-Arms by direction of Mr. Speaker, and motion passed suspending him for the remainder of the sitting, 345.		
In Committee—Deputy Chairman reported that Mr. McElhone had used certain words which he as Deputy Chairman had declared to be disorderly, and required Mr. McElhone to withdraw them. This the Honorable Member had declined to do, remarking, "Now you can do what you like," 479; Mr. McElhone ordered to attend in his place—Sergeant-at-Arms reported that he had failed to find Mr. McElhone—Mr. McElhone committed to the custody of Sergeant, and Speaker's warrant issued, 480; reported as put in execution, 483; motions made in reference to discharge of the Honorable Member from custody—Mr. McElhone admitted to the Bar to make explanation and apology and discharge authorized—Speaker directed Sergeant accordingly, 485, 486.		
DISSENT FROM MR. SPEAKER'S RULING :—		
Motion made for, and withdrawn, 49.		
Motion made for, and negatived, 4, 24, 25, 156-7, 565.		
DISTRESS FOR RENT ABOLITION BILL :—		
Motion made (<i>Mr. Walker</i>) for leave to bring in, 70; presented and read 1 ^o , 88; motion made for 2 ^o , and negatived, Order of the Day discharged, and Bill withdrawn, 107.		
DISTRIBUTION OF FUNDS IN SEMPILL'S ESTATES BILL :—		
Motion made (<i>Mr. William Clarke</i>) for leave to bring in, presented and read 1 ^o , 338; Order of the Day discharged, 349.		
DISTRIBUTION OF FUNDS IN SEMPILL'S ESTATES BILL (No. 2) :—		
Motion made (<i>Mr. William Clarke</i>) that Order of Leave be read, entry in Votes and Proceedings read by Clerk, presented and read 1 ^o , 349; read 2 ^o , committed, reported, report adopted, 366; read 3 ^o , passed, and sent to Council, 373; returned with amendments, 398; amendments agreed to, 429; assent reported, 461.		
DISTRICT COURT BAILIFFS :—		
Motion made (<i>Mr. Gould</i>) for a return showing the names of, and fees received by each during 1886 and to 30 June, 1887, distinguishing the several services for which the fees were paid, 48; Return to Order laid on Table, 492	2	635
DISTRICT COURTS ACT OF 1858 :—		
Annual Returns under 103 section, laid on Table, 524	2	735
DISTRICT GOVERNMENT BILL :—		
Motion made (<i>Sir Henry Parkes</i>) for Committee of the Whole, 16; House in Committee, 28; Resolution agreed to, 29; Message from Governor, 34; presented and read 1 ^o , 65; Order of the Day, postponed, 104, 602.	2	569
DIVISIONS :—		
Attendances of Members in, and Counts-out	1	653
IN THE HOUSE :—		
Interrupted by disorder and bars opened, 156.		
No Tellers for, 59, 140.		
Dissent from Mr. Speaker's Ruling, 25, 157, 565.		
"That the Question be now put," 24 (?), 156, 220, 221, 222, 468, 485.		
Adjournment of Debate, 4, 36, 146, 186.		
Business Days (<i>Sessional Order</i>), 9, 10.		
Hour of Meeting of the House, 224.		
Additional Standing Order (Right of Reply), 23.		
Local Option, 24.		
Franking Members Correspondence on Public Business, 24, 25 (?).		
Bankruptcy Bill, 36, 98.		
Borough of Balmain Wharves Bill, 41;		
Salaries of Civil Servants, 58.		
Sale of Intoxicating Drink in the Parliamentary Buildings, 59.		
Privilege—Transaction of Business while the Premier is not a Member, 76.		
Daily "Hansard," 89.		
Entry in Votes and Proceedings expunged by Order, 90 (?).		
Perpetual Trustee Company, 98.		
Newcastle Sand-drift Reclamation Act Repeal Bill, 113.		
Centenary of the Colony, 114.		

REFERENCES TO THE VOTES AND PROCEEDINGS, VOL. I.—13TH PARLIAMENT—SESSION, 1887-8.	PAPERS.
	VOL. PAGE.
D	
DIVISIONS—(continued) :—	
IN THE HOUSE—(continued) :—	
Additional Standing Order, No. 5, 129.	
Free Railway Passes to Ex-members of the Legislative Assembly, 129.	
Foreign Markets for Wool and Meat—Appointment of a Commission, 130.	
Hay and Deniliquin Tramway Bill, 145.	
Pharmaceutical Society of New South Wales Incorporation Bill, 146, 233.	
Purchase by the Government of Land adjoining the Australasian Steam Navigation Company's Wharf, Vote of Censure, 329.	
Forfeited Conditional Purchases within leasehold areas (<i>Edo's v. Tearle</i>), 353.	
Electoral Act Amendment Bill, 146.	
North Shore, Manly, and Pittwater Tramway and Railway Bill, 146.	
Colony of Australia Bill, 175 (2), 176.	
Australasian Naval Force Bill, 186 (2), 187.	
Import Duties on Agricultural Products, 233.	
Mr. Addison, Stipendiary Magistrate, 234.	
Agricultural Societies, 238.	
Conservation of Water in Lake Cudgellico and the Lower Lachlan River, 560.	
Government Railway Act Amendment Bill, 566.	
Chinese Restriction and Regulation Bill, 573.	
Property Tax Bill, 574 (2).	
The Speaker—Motion in reference to, 579.	
Crown Lands Act Further Amendment Bill, 595.	
Criminal Law Amendment Bill, 595.	
Electoral Act Amendment Bill, 603.	
The Mining Industry (Abolition of Timber Licenses), 608.	
Extension of Telegraph Lines, 609.	
Diseased Animals and Meat Bill, 609.	
Divorce Extension Bill, 451, 638.	
Adjournment of the House, 264.	
Totalizer Legalizing Bill, 273.	
Postage on Newspapers, 303, 304.	
Centenary Celebration Act Amendment Bill No. 2, 283.	
Attorney's Bills of Costs and Practice of Conveyancing Amendment Bill, 320.	
Crown Lands Bill (No. 2), 361.	
Privilege—Speech made by Mr. Haynes, 365.	
Government Railways Bill, 391.	
Postponement of Government Orders of the Day, 410.	
Sydney Hydraulic Power Company's Bill, 421.	
Thomas Thompson's Conditional Purchase made at Moama, 433.	
The Chinese, Vote of Censure, 468, 469 (2).	
Committal of Member to custody of Sergeant-at-Arms, 480.	
Privilege—Discharge of Member from custody of Sergeant-at-Arms, 485 (2), 486.	
Land Tax Bill, 501 (2), 586, 593.	
Import Duties on Agricultural Produce and Manufactures, 493, 509.	
Parliamentary Representatives Allowance Bill, 520, 548.	
Address of Condolence to Her Imperial Majesty the Empress Victoria, 530, 531.	
Privilege—Seat of Joseph Mitchell, Esq., 548.	
IN COMMITTEE OF THE WHOLE :—	
Borough of Balmain Wharves Bill, 657, 658.	
Municipal Roads and Streets Bill, 658.	
Payment of Members of the Legislative Assembly (<i>Resolution</i>), 659.	
Bankruptcy Bill, 661, 663, 665, 666, 667 (2), 668 (2), 669, 670, 671 (3), 672 (2), 673, 674, 683.	
Centenary of the Colony (<i>Resolution</i>), 675, 676 (2).	
Government Railways Bill, 676, 677, 678 (2), 679, 680, 681 (2), 682 (2), 683 (2), 684, 685, 686, 687 (3), 710 (2), 711 (2).	
Inland Waters Fisheries Bill, 689, 690 (2).	
Australasian Naval Force Bill, 691 (2).	
Public Works Bill, 693, 695, 696 (2), 697 (2).	
Eight Hours Bill, 699.	
Crown Lands Bill (No. 2), 701, 703, 705, 714, 715.	
Vine Diseases Act Amendment Bill, 707.	
Sydney Hydraulic Power Company's Bill, 709.	
Chinese Restriction and Regulation Bill, 717, 718, 727.	
Municipalities Act of 1867 Amendment Bill (No. 2), 719.	
Bills of Sale Act Amending Bill, 723.	
Land Tax Bill, 724 (3), 725, 728, 729 (3), 730 (3).	
Crown Lands Purchases Validation Bill, 731.	
Property Tax Bill, 741.	
IN COMMITTEE OF SUPPLY :—	
General Estimates for 1888 :	
Executive Council, 713.	
That Chairman leave Chair to Report <i>Point of Order</i> , 713.	
Board of Health, 720 (3).	
Loan Estimate :	
Fortifications, Warlike material, &c., 743.	
Do Warlike stores, &c., 744.	
IN COMMITTEE OF WAYS AND MEANS :	
Land Tax (<i>Resolution</i>), 711, 712.	
DIVORCE EXTENSION BILL :—	
Motion made (<i>Mr. Neild</i>) for leave to bring in, presented and read 1 ^o , 344 ; Order of the Day postponed, 361 ; read 2 ^o , committed, 451 ; reported with amendments, recommitted, reported 2 ^o with a further amendment, further recommittal negatived and report adopted, 507 ; read 3 ^o , passed, sent to Council, 513 ; returned with amendments, 638 ; motion made to consider amendments forthwith and negatived, 638 ; motion made to consider Council's amendments in Committee and withdrawn, 641.	
Motion made (<i>Mr. Neild</i>) for adjournment of the House in order to comment upon the action of the Home Government in reference to Bill of last Session, 342.	
Despatch respecting, laid on Table, 344	8
Motion made (<i>Mr. Neild</i>) in reference to action of the Home Government in reference to Bill of last Session, and Debate adjourned, 525 ; Order of the Day postponed, 573, 608.	1061

REFERENCES TO THE VOTES AND PROCEEDINGS, VOL. I—13TH PARLIAMENT—SESSION, 1887-8.	PAPERS.	
	VOL.	PAGE.
D		
DIVORCE EXTENSION BILL—(continued):—		
Petition presented (<i>Mr. Gould</i>) from William Macquarie Cowper, M.A., Commissary of the Bishop of Sydney, against the passing of the Bill, 499	8	1057
Petition presented (<i>Mr. Street</i>) by Ministers of Religion against the Bill, 506	8	1059
DOCKER, JUDGE:—		
Motion made (<i>Mr. J. P. Abbott</i>) for an Address to the Governor for papers, &c., relating to claim for travelling expenses by, 287; Return to Address laid on Table, 451	2	617
DOYLE, BRISBANE (See "OAKLEY PARK COAL-MINING COMPANY'S RAILWAY BILL").		
DOYLE, SARAH (See "OAKLEY PARK COAL-MINING COMPANY'S RAILWAY BILL.")		
DRAINAGE (See "SEWERAGE;" also "PARLIAMENTARY STANDING COMMITTEE ON PUBLIC WORKS.")		
DREDGE (See "PARLIAMENTARY STANDING COMMITTEE ON PUBLIC WORKS.")		
DRILLS (See "MINING"; also "STOCK").		
DRINK COMMISSION (See "COMMISSION").		
DRUMMOYNE PARK WHARF:—		
Motion made (<i>Mr. Carruthers</i>) for all leases, tenders, and correspondence relating to leasing of, 122; Return to Order, laid on Table, 199	3	1021
DUBBO (See "RAILWAYS").		
DUCKENFIELD COLLIERY (See "MINING").		
DUTY (See "FINANCE").		
E		
EASTGROVE:—		
RAILWAY CROSSING TO CONNECT GOULBURN:—		
Motion made (<i>Mr. Teece</i>) for papers, 386; Return to Order laid on Table, 454	6	971
EDDY, MR. E. M. G.:—		
Correspondence respecting the appointment of, as Chairman of the Railway Board, laid on Table, 537	6	625
EDUCATION (See also "STATISTICS"):—		
CHARLOTTE BRENNING:—		
Petition from, that she has served as teacher under the Department of Public Instruction for three years, that through being sent to places where great hardships had to be endured, her health was greatly effected, and having applied for removal, her resignation was accepted, and praying the appointment of a Select Committee, presented, 135	4	515
PUBLIC INSTRUCTION ACT:—		
Regulations under, laid on Table, 6 (?)	4	517, 519
Prosecution under Compulsory Clause, Information respecting, laid on Table, 437	4	501
RESUMPTIONS OF LAND FOR PUBLIC SCHOOL PURPOSES:—		
Notifications of, laid on Table, 70, 155, 246, 257, 341, 360, 408, 496, 553, 608	4	525 to 545
RESUMPTION OF LAND FOR SCHOOL PURPOSES, PARISH OF HOLDSWORTHY:—		
Motion made (<i>Mr. Gibbes</i>) for all papers in connection with the, 130; Return to Order laid on Table, 454	4	511
UNIVERSITY OF SYDNEY:—		
Amended By-laws, laid on Table, 6, 257(?)	4	557, 569, 571
Information respecting examination fees, laid on Table, 348	4	555
Report for 1887, laid on Table, 524	4	547
MR. J. A. SMITH, PUBLIC SCHOOL TEACHER AT COOLA CREEK:—		
Return to Order (<i>Second Session, 1887</i>), laid on Table (not printed), 6.		
TECHNICAL:—		
Report by Edward Combes, C.M.G., on, laid on Table, 28	4	229
FREE RAILWAY PASSES TO SCHOOL CHILDREN:—		
Motion made (<i>Mr. J. P. Abbott</i>) for all minutes and other documents, written or sent by any Minister or Officer of the Civil Service, in reference to the Resolution authorizing, passed last Session, 40; Return to Order, laid on Table, 231	6	711
CASE OF THOMAS DEAN:—		
Correspondence relating to, summoned at Balmain under the Public Instruction Act, laid on Table (not printed), 62.		
SCHOOL ATTENDANCE OFFICERS:—		
Copies of minutes, instructions, and circulars respecting, laid on Table, 75	5	493
SYDNEY GRAMMAR SCHOOL:—		
Report for 1886, laid on Table, 285	4	573
Report for 1887, laid on Table, 432	4	581
CLASSIFICATION OF TEACHERS:—		
Motion made (<i>Mr. Frank Farnell</i>) for return of information respecting 1B and 1A certificates, 361; Return to Order laid on Table, 389	4	489
AGRICULTURAL COLLEGE:—		
Motion made (<i>Mr. Kethel</i>) for Address to Governor for establishment of, and, by leave, withdrawn, 370.		
STATE CHILDREN'S RELIEF DEPARTMENT:—		
Report on, for year ended 5th April, 1888, 565	4	753
PUBLIC INSTRUCTION:—		
Report of the Minister on, for the year 1887, laid on the Table, 408; Annex XVII to, 425	4	1
Information respecting persons employed in Department who have attained the age of sixty years, laid on Table, 635	4	487
FOREST VALE SCHOOL:—		
Motion made (<i>Mr. Lyne</i>) for minutes and correspondence in reference to, 429; Return to Order laid on Table, 560	4	503
RESUMPTION OF PROPERTIES FOR SCHOOL PURPOSES, ELIZABETH AND CASTLEREAGH STREETS.		
Motion made (<i>Mr. Withers</i>) for Return showing date, amount of purchase money, &c., 463.		
EIGHT HOURS BILL:—		
Motion made (<i>Mr. Schey</i>) for Committee of the Whole, 36; House in Committee, Resolution agreed to, presented and read 1 ^o , 42; Order of the Day postponed, 77, 145, 252; read 2 ^o , committed; no Report from Committee, 342.		
ELECTIONS AND QUALIFICATIONS COMMITTEE (See "ELECTORAL").		

REFERENCES TO THE VOTES AND PROCEEDINGS, VOL. I—13TH PARLIAMENT—SESSION, 1887-8.	PAPERS.	
	VOL.	PAGE.
E		
ELECTORAL (See also "MINISTERIAL ELECTION BILL"; also "WENTWORTH ELECTORATE SUBDIVISION BILL") :—		
PADDINGTON :—		
Resignation of W. J. Trickett, Esq., and issue of Writ reported—Return of Writ, certifying to the Return of William Johnston Allen, Esq., reported, 249; Mr. Allen sworn, 253.		
NEWTOWN :—		
Death of Frederick Jamison Gibbes, Esq., issue and return of Writ, reported, Mr. Joseph Abbott sworn, 249.		
Resignation of William John Foster, Esq., reported and seat declared vacant, 269; issue and return of Writ, reported, Mr. Joseph Mitchell sworn, 303.		
WENTWORTH :—		
Resignation of W. P. Macgregor, Esq., and issue of writ reported, 1; return of writ certifying to election of T. F. De Courcy Browne, certain irregularities in holding the election, and proclamation curing the same, reported, 73; Mr. Browne sworn, 76.		
ROLLS :—		
For 1887-8, laid on Table, 257		
For 1880 to 1888, showing operation of expansive clauses of Electoral Act of 1884, laid on Table, 369	1	921
ELECTIONS AND QUALIFICATIONS COMMITTEE :—		
Speaker's Warrant laid on Table, 17, 269; maturity reported, 37, 287; Members sworn, 37 (?), 287; first meeting appointed, 53; leave given to adjourn <i>sine die</i> , 55, 296.		
<i>Seat of the Honorable Bernhard Ringrose Wise, Esquire.</i>		
Motion made (<i>Mr. Dibbs</i>) to refer, whether he has since his election accepted an office of emolument in having accepted a fee of fifty-five guineas from the Commissioner for Railways, in contravention of the 28th section of the Constitution Act, 53; Report brought up, 55.....	1	903
<i>Seat of John Haynes, Esquire.</i>		
Motion made (<i>Mr. Melville</i>) to refer, whether it has not and is not now vacant by reason of his becoming a bankrupt or an insolvent debtor, and negatived, 145.		
<i>Seat of Joseph Mitchell, Esquire.</i>		
Motion made (<i>Mr. Copeland</i>) to refer seat to, in consequence of alleged corrupt practices at the last election, and negatived, 548.		
<i>Election Petition—Paddington—Hellmrich v. W. J. Allen.</i>		
Mr. Speaker laid on Table Election Petition from Charles Hellmrich, alleging that at some polling booths votes were declared informal which were not informal and should have been counted for Petitioner, that the ballot papers were wrongly counted at some of the polling booths, that Mr. W. J. Allen was declared duly elected, and praying that Mr. Allen's election be declared null and void, that a scrutiny of the ballot papers be made by the Committee of Elections and Qualifications, and that your Petitioner may be declared duly elected—Petition referred to Committee, 269; Report brought up, 296	1	891
ACT :—		
Motion made (<i>Mr. Sehey</i>) for amendment so as to give the franchise to members of the Police Force, Permanent Artillery, and to all other adult males who shall not be otherwise under disability, and withdrawn, 25.		
NAMOI DISTRICT :—		
Motion made (<i>Mr. Dangar</i>) for a return showing entire revenue from, under Crown Lands, Mining Leases and Licenses, Miners' Rights and Timber Licenses, 41.		
ST. LEONARDS :—		
Resignation of Sir Henry Parkes as a Member for, reported—seat declared vacant, 73; issue and return of writ reported—Sir Henry Parkes sworn, 87.		
CENTRAL CUMBERLAND :—		
Resignation of A. H. McCulloch, jun., Esq., reported,—seat declared vacant, 222, 419; issue and return of Writ reported, 249, 463; Mr. A. H. McCulloch, jun., sworn, 253; David Buchanan sworn, 463.		
Resignation of Varney Parkes, Esq., reported,—seat declared vacant, 311; issue and return of Writ reported, 339; Mr. John Nobbs sworn, 342.		
ELECTORAL ACT AMENDMENT BILL :—		
Motion made (<i>Mr. Haynes</i>) for leave to bring in, 17; presented and read 1 ^o , 35; Order of the Day postponed, 77; motion made for 2 ^o and negatived, Order of the Day discharged and Bill withdrawn, 146.		
Motion made (<i>Sir Henry Parkes</i>) for leave to bring in, presented and read 1 ^o , 592; read 2 ^o , committed, 603.		
ELECTORATES OF THE GWYDIR AND INVERELL BOUNDARIES AMENDMENT BILL :—		
Motion made (<i>Mr. Moore</i>) for leave to bring in, presented and read 1 ^o , 484.		
Petitions from residents of Little Plain, near Inverell, in favour of the passing of the Bill, 585.		
ELECTRIC CARS (See "TRAMWAYS").		
ELECTRIC LIGHT (See also "PARLIAMENT") :—		
THE "GULCHER" MACHINE :—		
Motion made (<i>Mr. Thompson</i>) for all letters, correspondence, &c., relating to, purchased by Telegraph Department, 147; Returns to Order, laid on Table, 231, 273	4	1191, 1197
APPARATUS PURCHASED BY GOVERNMENT :—		
Motion made (<i>Mr. Wall</i>) for return of, giving dates of purchase, time of delivery, and authority of purchase, and whether in use, 267.		
MACQUARIE LIGHTHOUSE :—		
Motion made (<i>Mr. Wall</i>) for correspondence between Colonial Architect and the Superintendent of Telegraphs, 267; Return to Order, laid on Table, 543	4	1199
ELECTRIC LIGHTING BILL (See "SYDNEY AND SUBURBAN ELECTRIC LIGHTING BILL").		
ELIZABETH AND CASTLEREAGH STREETS PROPERTY (See "EDUCATION").		
ELLIS DR. (See "RABBIT PEST").		
EMERY, MR. G. H. (See "CIVIL SERVICE").		
EMERY V. BARCLAY (See "ADMINISTRATION OF JUSTICE").		
EMPLOYERS LIABILITY ACT AMENDMENT BILL :—		
Motion made (<i>Mr. Garrard</i>) for leave to bring in, 40.		
EMPLOYES (See "RAILWAYS"; also "TRAMWAYS").		
EMPRESS VICTORIA OF GERMANY (See "ADDRESS").		
ENDOWMENT TO MUNICIPALITIES :—		
Opinions of Attorneys-General in years 1876 and 1888 on, laid on Table, 642.....	2	273
ENGINES (See "RAILWAYS").		
ENGINE-SHEDS (See "RAILWAYS").		

REFERENCES TO THE VOTES AND PROCEEDINGS, VOL. I—13TH PARLIAMENT—SESSION, 1887-8.	PAPERS.	
	VOL.	PAGE.
E		
ESSEX-STREET ALIGNMENT BILL:—		
Motion made (<i>Mr. Garrett</i>) for leave to bring in, presented and read 1 ^o , 437; read 2 ^o , committed, reported without amendment, report adopted, 561; read 3 ^o , passed and sent to Council, 567.		
ESTIMATES (See "FINANCE").		
EVANS COMBINATION TRUCK (See "RAILWAYS").		
EXAMINATION FEES See ("UNIVERSITY OF SYDNEY").		
EXAMINER OF ACCOUNTS (See "ASSISTANT-EXAMINER OF ACCOUNTS").		
EXAMINER OF COAL-FIELDS:—		
Report of, on charges made against him in the Legislative Assembly, laid on Table, 273	8	217
EXAMINERS OF TITLES (See "CIVIL SERVICE").		
EXCLUSION OF STRANGERS:—		
Sessional Order passed, 12.		
EXHIBITION (See "ADELAIDE JUBILEE INTERNATIONAL EXHIBITION"; also, "CENTENNIAL INTERNATIONAL EXHIBITION, MELBOURNE").		
EXPENDITURE:—		
Statement of, on National and Local Works in the Colony, from 1860 to 1886, laid on Table, 28...	8	1231
Statement of Annual, of Colony during 1881 to 1886, and the actual and estimated during 1887; also population and rate per head, laid on Table, 219	3	495
Statement of Annual, of Colony on account of Loan Services during 1881 to 1886, and the actual and estimated, during 1887, the population and rate per head, laid on Table, 219	3	503
EXPLANATORY TESTRACTS:—		
Of Sums Estimated and Voted.....	3	851
EXPORTS (See "STATISTICS").		
EXPLOSIVE GAS (See "MINING")		
EXPLOSIVES:—		
Amended Rates and Charges for Lightering, Delivering, and Storing laid on Table, 280.....	8	1207
EXPUNGED ENTRY:—		
By Order of Assembly, 90.		
Speaker states course intended to be pursued to record,—motion made to instruct Speaker as to entry in Votes and Proceedings, 91.		
EXTRADITION PAPERS:—		
Despatch respecting authentication of, laid on Table, 352	8	1067
F		
FACTORIES AND WORKSHOPS REGULATION BILL:—		
Received from Legislative Council, read 1 ^o ; printed, 614; Order of the Day postponed, 619.		
FARMS AND FREIGHTS (See "RAILWAYS").		
FARM PRODUCE (See "AGRICULTURAL PRODUCTS").		
FARNELL, MR. J. S., M.P.:—		
Leave of Absence granted to, 437.		
FEES (See "CIVIL SERVICE"; also "UNIVERSITY OF SYDNEY").		
FENCING (See also "CROWN LANDS"; also, "CROWN LANDS ACT FURTHER AMENDMENT BILL"):—		
Notification of further amendment of Section 5 of Schedule of Classes, under the Crown Lands Act, laid on Table, 40, 199, 613	5	585, 587, 589
FENNELL, STEPHEN (See "CROWN LANDS PURCHASES VALIDATION BILL").		
FERGUSON, DAVID A., ESQ., M.P.:—		
Leave of Absence granted to, for four weeks, 17, 112.		
FERGUSON, MR. GEORGE ROBERT EDWARD (See "CROWN LANDS").		
FERRIES:—		
GOVERNMENT:—		
Motion made (<i>Mr. Bowes</i>) for abolition of Tolls and Dues on, 608.		
FEVER, OUTBREAK OF, AT GLENDUART, MORUYA:—		
Motion made (<i>Mr. Lakeman</i>) for all papers relating to, 519; Return to Order, laid on Table, 578.	2	239
FIELD OF MARS COMMONS:—		
Returns to Order (<i>Second Session of 1887</i>), laid on Table, 103, 432	5	827
FINANCE (See also, "PROPERTY TAX BILL," and "LAND TAX BILL"; also "FINANCE"):—		
REVENUE, RECEIPTS, AND EXPENDITURE:—		
Abstracts for Quarter ended 30th June, 1888, laid on Table, 561.		
RECEIPTS AND EXPENDITURE:—		
Statement of, together with the Auditor General's Report thereon for 1886, laid on Table, 2	3	509
Do do do for 1887, laid on Table, 563 ...	3	657
BANK LIABILITIES AND ASSETS:—		
For the Quarter ended 30th June 1887, laid on Table 5	3	843
Do 30th September, 1887, laid on table, 135.....	3	845
Do 31st March, 1888, laid on Table, 475	3	847
BANKING, LAND, BUILDING, AND INVESTMENT COMPANIES:—		
General Summary for Quarter ended 31st March, laid on Table, 475.....	3	849
SUPPLY:—		
Committee of, Sessional Order passed, 11.		
Motion made (<i>Mr. Burns</i>) for House to go into Committee, 174, 295, 345, 409, 433, 452, 476, 480, 544, 548, 553, 554, 610, 613, 619.		
House in Committee, 201, 242, 295, 345, 409, 433, 452, 476, 480, 544, 548, 553, 554, 610, 613, 619.		
Resolutions reported, 201, 242, 295, 345, 409, 480, 553, 619.		
Resolutions agreed to, 201, 242, 295, 345, 409, 480, 553, 625.		
WAYS AND MEANS:—		
Committee of, Sessional Order passed, 11.		
Motion made (<i>Mr. Burns</i>) for House to go into Committee, 174, 295, 346, 409, 430, 481, 501, 554, 561, 627.		
House in Committee, 201 (<i>Financial Statement</i>), 229, 234, 241, 242, 247, 295, 346, 409, 430, 481, 501, 554, 561, 627.		
Resolutions reported, 242, 248, 295, 346, 409, 430, 481, 554, 561, 627.		
Resolutions agreed to, 242, 248, 295, 346, 409, 430, 481, 554, 561, 627.		
Estimates for 1888 (<i>Mr. Burns</i>) laid on Table, 201, 613.		

REFERENCES TO THE VOTES AND PROCEEDINGS, VOL. I—13TH PARLIAMENT—SESSION, 1887-8.	PAPERS.	
	VOL.	PAGE.
F		
FINANCE—(continued) :—		
EXPENDITURE ON NATIONAL AND LOCAL WORKS :—		
Statement of, in the Colony, from 1860 to 1886, laid on Table, 23.	8	1231
IMPORT DUTIES ON AGRICULTURAL PRODUCTS :—		
Motion made (<i>Mr. Copeland</i>) that it is desirable to encourage the agricultural interest by imposing import duties on grain, beans, peas, barley, oats, hay, chaff, flour, meal, bran, pollard, sharps, and potatoes, and Debate adjourned, 169; negatived, 233.		
Petition presented (<i>Mr. Copeland</i>) representing that the farming industry is in a deplorable condition, and praying the House to grant relief, read by the Clerk, 492	3	873
Petition presented (<i>Mr. Copeland</i>) from farmers of Inverell, in favour of specific duty on grain, 492.	3	871
Motion made (<i>Mr. Copeland</i>) for moderate import duties on, and on all articles which can be locally manufactured, and the Question not having been put at 7 o'clock, Government business took precedence, 493; Order of the Day postponed, 506; Debate resumed and Question negatived, 509.		
Petition presented (<i>Mr. Crouch</i>) in favour of, and praying the House to pass <i>Mr. Copeland's</i> Resolutions, 496.	3	869
Petition presented (<i>Mr. Copeland</i>) from farmers, agriculturalists, and labourers of Central New England, praying for the imposition of import duties on agricultural productions that can be grown in the Colony, and read by the Clerk, 505	3	877
Petition presented (<i>Mr. Ewing</i>) from Public Meeting, held at Tatham, in favour of, 519.	3	875
ESTIMATES :—		
Message No. 14 (<i>Mr. Burns</i>) recommending accompanying for 1888, and Supplementary for 1887, and previous years, laid on Table, 200.	3	1
Ways and Means for 1888 (<i>Mr. Burns</i>) laid on Table, 201, 613.	3	371, 461
Schedule to, for 1888, showing total remuneration of all Public Officers, laid on Table, 228	3	153
Mr. Speaker ruled as properly before the House, notwithstanding that the Salaries shown were lower than those provided for by the Civil Service Act, 433.		
Mr. Speaker ruled that Schedules A, B, C, were not open for discussion, as they were already provided for by Act of Parliament, 433.		
Mr. Speaker declined to overrule the decision of Deputy Chairman in reference to words used by <i>Mr. McElhone</i> in Committee of Supply, 452.		
Message No. 56 (<i>Mr. Burns</i>) asking for Return of that portion of the Estimates-in-Chief having reference to the Colonial Secretary's Department, 491	3	259
Message No. 66, recommending accompanying Amended Estimates for Departments under control of Colonial Secretary, 545	3	295
Message No. 73 (<i>Mr. Burns</i>) recommending accompanying Further Supplementary for 1887 and Additional for 1888, laid on Table, 610	3	331
Message No. 74 (<i>Mr. Burns</i>) recommending accompanying Further Additional for 1888, laid on Table, 610	3	353
Message No. 75 (<i>Mr. Burns</i>) recommending accompanying Additional Estimate on Account of Repayment of Loans, laid on Table, 610.	3	359
Message No. 76 (<i>Mr. Burns</i>) recommending accompanying Loan Estimates for 1888, laid on Table, 610.	3	365
EXPLANATORY ABSTRACTS :—		
Of sums estimated and voted	3	851
FINANCIAL STATEMENT :—		
Made by <i>Mr. Burns</i> , 201, 361, 610.		
ACCOUNTS :—		
Deficit for 1886 and previous years, laid on Table, 208	3	501
Annual Expenditure of Colony, during 1881-6, and the actual and estimated Expenditure during 1887, showing population and rate per head, laid on Table, 219	3	405
Annual Expenditure of Colony, during 1881-6, on Loan Services, and the actual and estimated Expenditure during 1887, showing population and rate per head, laid on Table, 219	3	503
Statement of Consolidated Revenue Fund for 1888, laid on Table, 219	3	497
Return showing the Amounts due by the Consolidated Revenue Fund to the Loan Funds and Trust Funds on 30 April, 1888, laid on Table, 538	3	409
Adjournment of the House moved to consider statement of Treasurer in reference to the Public Accounts, 561.		
FINANCIAL POLICY OF THE GOVERNMENT—VOTE OF CENSURE :—		
Motion made (<i>Mr. Dibbs</i>) that Financial Policy of the Government is unsatisfactory, amendment moved confining the question to such of the financial proposals of the Government as refer to the reduction of the Civil Service Salaries, and debate adjourned, 208; debate resumed and further adjourned, 210, 216; debate resumed, disorder arose, and fourteen members removed from the Chamber, 220, 221; amendment and original motion negatived, 222.		
IMPORT DUTY ON TIMBER :—		
Petition from Proprietors of Saw Mills that if the reduction of the duty be carried, the Colonial trade will be crippled, and praying that the reduction be not sanctioned, 240.	3	879
INSCRIBED STOCK ACT OF 1883 :—		
Fifth Report on the Creation Inscription and issue of Stock under, laid on Table, 257.	3	505
PROPOSED NEW TARIFF :—		
Petition from residents of Broughton Creek, Brogher's Creek, Broughton Vale, and Kangaroo Valley, against the abolition of the Customs Duties on Farm Produce, presented and read by the Clerk, 252.	3	881
LOAN OF INSCRIBED STOCK :—		
Correspondence by Cable in reference to floating of, laid on Table, 420	3	815
ROAD TRUSTS ACCOUNTS :—		
Half-year ending 30th June and 31st December, 1887, laid on Table, 505	5	937
ASSISTANT EXAMINER OF ACCOUNTS, TREASURY :—		
Return respecting applications for position of, laid on Table, 524	2	111
FINANCIAL BUSINESS :—		
Ministerial Statement made by <i>Sir Henry Parkes</i> , 405, 501.		
FIRE BRIGADES ACT.		
GOULBURN BOARD :—		
Report for 1887, laid on Table, 302.	2	609
TAMWORTH BOARD :—		
Regulation of, laid on Table, 6, 578.	2	611, 613
METROPOLITAN BOARD :—		
Report for 1887, laid on Table, 378.	2	571
DENILIQUIN BOARD :—		
Report for 1887-8, laid on Table, 462.	2	605
Regulations, laid on Table, 634.	2	607

REFERENCES TO THE VOTES AND PROCEEDINGS, VOL. I—13TH PARLIAMENT—SESSION, 1887-8.	PAPERS.	
	VOL.	PAGE.
F		
FISHERIES (See also "INLAND WATERS FISHERIES BILL") :— Report on, by the Commissioners, up to 31st December, 1886, laid on Table, 223	8	1069
MR. OLIVER, LATE INSPECTOR :— Motion made (<i>Mr. Dawson</i>) for papers connected with removal of, 303; Return to Order, laid on Table, 442	2	123
FITZROY WATERFALLS :— Plan of forty-five portions of Crown Lands situated near the village of Yarrunga at, measured for sale, laid on Table, 228	5	201
FLETCHER, JAMES, ESQ., M.P. :— A MEMBER FOR NEWCASTLE :— Removed from Chamber by Sergeant-at-Arms, by direction of Mr. Speaker, and suspended for the remainder of the Sitting, for assaulting Mr. Haynes, a Member for Mudgee, 345.		
FORBES (See also "RAILWAYS," "MUNICIPAL"; also PUBLIC BUILDINGS"; also CROWN LANDS") :— Motion made (<i>Mr. Stokes</i>) for papers in connection with Special Audit of Municipal Accounts, 325; Return to Order, laid on Table, 334	2	279
FORCES (See "MILITARY").		
FOREIGN DESERTERS ACT, 1852 :— Despatches respecting, laid on Table, 135, 356	8	1181, 1183
FOREIGN MARKETS FOR WOOL AND MEAT :— APPOINTMENT OF A COMMISSION :— Motion made (<i>Mr. Waddell</i>) for, to obtain all possible information to assist in opening up 129 and negatived, 130.		
FORESHORES OF SYDNEY HARBOUR :— DR. BOTTBRELL'S CLAIM TO :— Motion made (<i>Mr. Lyne</i>) for all papers connected with, 40; Return to Order, laid on Table, 185.	3	885
FOREST BRANCH (See "MINING").		
FOREST VALE SCHOOL (See "EDUCATION").		
FORESTS (See "STATE FORESTS AND FOREST RESERVES.")		
FORFEITED CONDITIONAL PURCHASES (See "CROWN LANDS")		
FORMAL BUSINESS :— Sessional Order passed, 10.		
FORMATION OF STREET, NORTH OF THE GENERAL POST OFFICE :— Message from His Excellency the Governor recommending that provision be made for, 383. Motion made (<i>Mr. Roberts</i>) for Committee of the Whole to consider Resolutions, 390; Order of the Day postponed, 410; House in Committee, 416, 479, 484, 487. Motion made (<i>Mr. Dibbs</i>) for plan showing proposed new street, and also <i>Mr. Dibbs's</i> proposed alteration, 454; Return to Order, laid on Table (<i>as an exhibit only</i>), 602. Correspondence and Papers respecting, laid on Table, 434	4	1141
FOSTER, GEORGE (See "CROWN LANDS").	4	1125
FOSTER, WILLIAM JOHN ESQ., M.P. :— Resignation of, as a Member for Newtown, reported, and seat declared vacant, 269.		
FRANKING MEMBERS CORRESPONDENCE (See "POSTAL").		
FRAUD, ALLEGED (See "STAMP DUTIES ACT"; also "RAILWAYS").		
FREDERICKTON :— PUBLIC WHARF AT, MACLEAY RIVER :— Notification of resumption under Lands for Public Purposes Acquisition Act, of land in parish of Kempsey, county of Gordon, laid on Table, 432	3	1049
FREE PASSES (See "RAILWAYS").		
FREE PUBLIC LIBRARY (See "BY-LAWS"; also "SYDNEY FREE PUBLIC LIBRARY").		
FRENCH MILITARY POSITS (See "NEW HEBRIDES").		
FRIDAY (See "ADDITIONAL SITTING DAY").		
FRIEZE WORK (See "TELEPHONES.")		
FRUIT GROWING :— Petition from New South Wales Fruitgrowers Union that they have agreed upon certain principles for the protection of the industry, which they pray should be embodied in an Act, presented, 127.	8	1185
FUEL BILL :— Motion made (<i>Mr. Alfred Allen</i>) for Committee of the Whole, 40; Order of the Day postponed, 58, 107; House in Committee, Resolution agreed to, 253; presented and read 1 ^o , 263; Order of the Day postponed, 353, 425, 476, 598.		
FUGITIVE CRIMINALS :— Despatch in reference to surrender of, laid on Table, 285	8	1281
G		
GAOLS (See also "ADMINISTRATION OF JUSTICE") :— PARRAMATTA :— Notification of resumption, under Lands for Public Purposes Acquisition Act, of land in parish of Field of Mars, required for extension of, laid on Table, 231	4	1227
GARRARD, JACOB, ESQ., M.P. :— Appointed Chairman of Committees for the day only, 359, 363, 385. Appointed with three others to act temporarily as Chairman of Committees in the absence of the Member appointed to that office, 389. Mr. Speaker calls on, to act as Deputy Chairman for the day only, 403, 425, 432, 468, 484, 493, 500, 513, 538, 543, 573.		
GARRETT, THE HON. THOMAS, M.P. (See also "TERALBA COAL MINING RESERVE") :— Resignation of, as Minister for Lands, 613.		
PRIVILEGE— <i>Garrett v. Dibbs</i> :— Motion made (<i>Mr. Dibbs</i>) that the Crown Solicitor be instructed to defend the action <i>Garrett v. Dibbs</i> in the interests of the privileges of this House, and negatived, 326.		
MINERAL LANDS HELD BY :— Return respecting, laid on Table, 578.....	8	263
GARSED MR. JOHN :— Motion made (<i>Mr. Hurley</i>) for letters addressed to the Attorney-General, on 8th June and 21st July, with the reply dated 14th September, 1887, 131; Return to Order, laid on Table, 185...	8	1227
GARVAN, MR. :— A MEMBER FOR EDEN :— Declared guilty of persistent disorder and removed by the Sergeant-at-Arms from the Chamber, 220.		

REFERENCES TO THE VOTES AND PROCEEDINGS, VOL. I—13TH PARLIAMENT—SESSION, 1887-8.	PAPERS.	
	VOL.	PAGE.
G		
GENERAL BUSINESS:—		
Sessional Order passed, as to precedence of, 10.		
Notices of Motions postponed in a bunch, 162, 208, 242, 248, 487.		
Notice of Motion postponed, 502.		
Orders of the Day postponed in a bunch, 248, 487.		
GENERAL POST OFFICE (See "POSTAL").		
GHINNY GHINNY:—		
WHARF OVER MANNING RIVER:—		
Notification of resumption under Lands for Public Purposes Acquisition Act of land in Parish of Cudal, County of Macquarie, laid on Table, 475	3	1051
GIBBES, FREDERICK JAMISON, ESQUIRE:—		
Death of the Honorable Member for Newtown reported, 249.		
GIPPS, MR. F. B.:—		
Letter, dated 5th July, 1888, as an Appendix to Return respecting Kenny Hill and Pott's Hill Reservoir Schemes, laid on Table, 578.....	5	869
GLEBE ISLAND ABATTOIRS:—		
Petition, Municipal District Council of Leichhardt, for the abolition of, presented, 16	8	669
GLENDUART, MORUYA:—		
OUTBREAK OF FEVER:—		
Motion made (<i>Mr. Lakeman</i>) for copies of all papers relating to, 519; Return to Order, laid on Table, 578	2	239
GLENTHORNE:—(See "ROADS").		
GOLD MINING (See "MINING").		
GOULBURN (See also "SAINT SAVIOUR'S GLEBE LAND LEASING BILL"; also "RAILWAYS"):—		
Report of Fire Brigades Board for 1887, laid on Table, 302	2	609
GOULBURN AND TUENA TRAMWAY BILL:—		
Petition presented (<i>Mr. Stevenson</i>) for leave to bring in, 492; leave given, presented and read 1 ^o , 496; referred to Select Committee, 500; Report brought up, 523; Order of the Day postponed, 585; motion made for 2 ^o , and debate adjourned, 599; Order of the Day postponed, 628	2	907
GOULD, ALBERT JOHN, ESQ., M.P.:—		
Speaker's Warrant appointing, as Member of Elections and Qualifications Committee, laid on Table, 269; maturity of Warrant reported and Member sworn, 287.		
Added to Standing Orders Committee, 280.		
Appointed temporarily with three others to act as Chairman of Committees in the absence of the Member appointed to that office, 389.		
Mr. Speaker calls on to act as Deputy Chairman of Committees for the Day only, 420, 437, 454, 476, 519, 565.		
GOVERNMENT (See also "TRAMWAYS"):—		
Motion made (<i>Mr. Garvan</i>) for adjournment of the House in reference to certain actions of, and Point of Order raised, That notice did not state "a definite matter" of public importance. Mr. Speaker pointed out that, by a previous decision of the House, he had been relieved of the responsibility of deciding the point, which should have been taken before the motion was stated, 635; motion negatived, 635.		
ASYLUMS (See "ASYLUMS").		
BUSINESS:—		
Precedence of, Sessional Order passed, 10.		
Do. after 7 o'clock on Friday (additional day), 103, 123, 140, 166, 234.		
Do. after 7 o'clock on Tuesday, 408, 422, 433, 452, 476, 493, 508, 525, 543, 561, 580, 609.		
Orders postponed in a bunch, 417, 430, 463, 468, 487, 502, 509, 628.		
ELECTRIC LIGHT APPARATUS PURCHASED BY:—		
Motion made (<i>Mr. Wall</i>) for return, giving dates of purchase, time of delivery, &c., and authority of purchase, and whether in use, 267.		
PRINTING OFFICE:—		
Annual Return to Order, for 1887 (<i>Session 1883-4</i>), laid on Table, 302.....	8	1187
Motion made (<i>Mr. Frank Smith</i>) for return in reference to private work done at Government Printing Office, 500; Return to Order laid on Table, 515	8	1197
PREMISES RENTED BY:—		
Further Return to Order (<i>Second Session 1887</i>), laid on Table, 191	8	1249
PURCHASE BY, OF LAND ADJOINING THE AUSTRALASIAN STEAM NAVIGATION COMPANY'S WHARF:—		
Motion made (<i>Mr. Melville</i>) for a Select Committee to inquire into and report upon, Committee appointed by ballot, 29; Report brought up, 305	3	917
Motion made (<i>Mr. Dibbs</i>), That the evidence of the Select Committee discloses injudicious and unsatisfactory administration by the Government, and that the amount paid was in excess of its value, 329.		
Correspondence respecting, laid on Table, and referred to Select Committee, 51	3	1011
PURCHASE BY, OF AUSTRALASIAN STEAM NAVIGATION COMPANY'S WHARF:—		
Motion made (<i>Mr. Trickett</i>) for all claims, correspondence, valuations, &c., connected with, 136; Return to Order, laid on Table, 191	3	1013
SAVINGS BANK:—		
Statement of Accounts for 1887, 356	3	819
GOVERNMENT RAILWAYS ACT AMENDMENT BILL:—		
Message from Governor, 539; motion made (<i>Sir Henry Parkes</i>) for Committee of the Whole, 546; House in Committee, resolution agreed to, presented, and read 1 ^o , 561; read 2 ^o , committed, reported without amendment, report adopted, 567; read 3 ^o , passed, 573; sent to Council, 574; returned without amendment, 593; Assent reported, 619.	6	1105
GOVERNMENT RAILWAYS BILL:—		
Motion made (<i>Sir Henry Parkes</i>) for Committee of the Whole, 16; House in Committee, resolution agreed to, 29; Message from Governor, 35; presented and read 1 ^o , 52; motion made for 2 ^o , and debate adjourned, 104; resumed and further adjourned, 115; resumed, read 2 ^o , and committed, 119; further considered in Committee, 123, 136; reported with amendments, 136; recommitted, 152; further considered in Committee, and reported 2 ^o , with further amendments, 162; recommitted and reported 3 ^o , with further amendments, 201; report adopted, 225; Order of the Day postponed, 240; read 3 ^o , passed, and sent to Council, 258; returned with amendments, 378; amendments agreed to, disagreed to, amended and agreed to, Message to Council, 390; Council does not insist on amendment, but proposes one in lieu thereof, agrees to Assembly's amendment on Council's amendment, insists on amendment, and does not insist on amendment, 417; motion made for consideration in Committee of the Whole of Message, and amendment moved (<i>Mr. Dibbs</i>), and negatived, to lay Bill aside, 425; Speaker ruled amendment of Council did not infringe on Assembly's rights, 426; further considered, agrees to amendment, and does not insist upon disagreement to amendment, Message to Council, 425; Assent reported, 461.	6	1107

REFERENCES TO THE VOTES AND PROCEEDINGS, VOL. I.—13TH PARLIAMENT—SESSION, 1887-8.	PAPERS.	
	VOL.	PAGE.
G		
GOVERNOR :—		
Message from, delivered by Usher of the Black Rod, 1, 642.		
Opening Speech, 2; Address in Reply, 3, 4; Answer to Address, 5.		
Prorogation Speech, 643.		
"GRACE, EDWARD" (See "CROWN LANDS PURCHASES VALIDATION BILL").		
"GRADY, CORNELIUS" (See "CROWN LANDS").		
GRAFTON (See "ELECTORAL").		
GRAFTON SCHOOL OF ARTS TRUSTEES ENABLING BILL :—		
Petition presented (<i>Mr. See</i>) for leave to bring in, 174; leave given, presented and read 1 ^o , 181; referred to Select Committee, 185; Report brought up, 224; Order of the Day postponed, 325, 369; read 2 ^o , committed, reported without amendment, report adopted, 507; Order of the Day postponed, 593, 628.	2	919
GRAIN (See "AGRICULTURAL PRODUCTS").		
GRANT, ALEXANDER OGILVIE (See "HUNTER-STREET, NEWCASTLE, EXTENSION BILL").		
GRANTS (See "ORIGINAL GRANTS OF LAND BOUNDARIES BILL;" see also "ROADS").		
GRANVILLE (See "RAILWAYS").		
GRATUITIES (See "CIVIL SERVICE").		
GREAT NORTHERN AND NORTH-WESTERN RAILWAYS (See "RAILWAYS").		
GREVILLE (See "TERALBA COAL-MINING RESERVE").		
"GULCHER" MACHINE (See "ELECTRIC LIGHT").		
GUNNEDAH (See also "ROADS"; also "BY-LAWS") :—		
OSRIC-STREET :—		
Motion made (<i>Mr. Goodwin</i>) for all correspondence respecting the flooding of, by a railway drain, with all reports, plans, &c., relating to same, 22; Return to Order, laid on Table, 122	6	1077
"GUTHRIE," S.S. :—		
Return respecting Chinese passengers by, laid on Table, 454	2	211
GUYRA (See "RAILWAYS").		
GWYDIR ELECTORATE (See "ELECTORATES OF THE GWYDIR AND INVERELL BOUNDARIES AMENDMENT BILL").		
H		
"HANSARD" :—		
DAILY :—		
Motion made (<i>Mr. Carruthers</i>) for adoption of Report from Select Committee of last Session, and negatived, 88.		
SHORTHAND WRITING SERVICES :—		
Motion made (<i>Mr. Walker</i>) for a Return showing amount paid for, in connection with Commissions and Boards of Inquiry since 1st January, 1886, and the number and name of Commissions and Boards of Inquiry attended by staff of, 232.		
HARBOURS (See also "PARLIAMNTARY STANDING COMMITTEE ON PUBLIC WORKS").		
TRUSTS :—		
Motion made (<i>Mr. Martin</i>) that the Government should immediately resume the whole of the wharf and foreshores requisite at Port Jackson and at Port Hunter, Newcastle, with a view to form, with large powers, and by leave withdrawn, 59.		
DEFENCE :—		
Correspondence respecting Major Parrott's Report on Coast and, laid on Table, 84.....	2	63
AND RIVERS DEPARTMENT :—		
Motion made (<i>Mr. Frank Farnell</i>) for return of officers, length of service and pay, and the number of articulated pupils and their rates of pay, 500; Return to Order, laid on Table, 635...	2	119
HARDEN RAILWAY STATION :—		
Motion made (<i>Mr. Gordon</i>) for return of goods and passenger traffic, and revenue and expenditure at, 294; Return to Order laid on Table, 338	6	741
HARRISON JOHN (See "CROWN LANDS").		
HASSALL, MR. :—		
MEMBER FOR THE GWYDIR :—		
Declared guilty of persistent disorder and removed by the Sergeant-at-Arms from the Chamber, 220.		
HAUGHTON AND PALMER (See "MINING").		
HAY AND DENILQUIN TRAMWAY BILL :—		
Petition presented (<i>Mr. R. B. Wilkinson</i>) to proceed with Bill under 65th Standing Order, 21; presented and read 1 ^o , 22; motion made for 2 ^o , and debate adjourned, 77; debate resumed and 2 ^o negatived, 145.		
HAYNES, JOHN, ESQUIRE, M.P. :—		
Motion made (<i>Mr. Melville</i>) to refer to Elections and Qualifications Committee, to report whether the Seat of, as a Member for Mudgee, has not and is not now vacant by reason of his becoming a bankrupt or insolvent debtor, and negatived, 145;		
A MEMBER FOR MUDGEE :—		
Assaulted whilst addressing the Chair by Mr. Fletcher, 345.		
PRIVILEGE :—		
Mr. Melville called attention to speech reported in the <i>Australian Star</i> and moved that the statement be read by the Clerk, 364; Statement read by the Clerk, and motion made (<i>Mr. Melville</i>) censuring the Honorable Member, and negatived, 365.		
HEALTH BOARD (See "RABBIT PEST"; also "TYPHOID FEVER").		
HELLMRICH, MR. CHARLES (See "ELECTORAL").		
HERREN, MICHAEL (See "CROWN LANDS PURCHASES VALIDATION BILL").		
HOGAN, PATRICK (See "CROWN LANDS PURCHASES VALIDATION BILL").		
HOLDSWORTHY (See "EDUCATION").		
HOMEBUSH (See "RAILWAYS").		
HOPKINS, W. A. (See "ADMINISTRATION OF JUSTICE").		
HORSES (See "TELEGRAPHS").		
HOSPITALS :—		
PATIENTS RECEIVED INTO, FROM PUBLIC WORKS :—		
Return to Order (<i>Second Session 1887</i>), laid on Table, 6; referred to Select Committee on "Deductions from wages of employes for medical attendance," 462	4	781
PRINCE ALFRED :—		
Motion made (<i>Mr. Hassall</i>) for all correspondence between the University and W. C. Wilkinson, Esq., M.P., relative to appointment of Pathologist or Physician to, 231; Return to Order, laid on Table, 257	4	775

REFERENCES TO THE VOTES AND PROCEEDINGS, VOL. I—13TH PARLIAMENT—SESSION, 1887-8.	PAPERS.	
	VOL.	PAGE.
H		
HOUR OF MEETING (See "ASSEMBLY").		
HOUSES OF PARLIAMENT (See "PARLIAMENT").		
HULBERT, THE REV. DANIEL P.M. :—		
Petition from, that for 39 years he was in the direct pay of Her Imperial Majesty and for over 30 years occupied the position of Stipendiary Pastor in Goulburn Church District, but has not received the revenues of the office, and praying the appointment of a Select Committee for investigation, presented, 144	8	1299
Petition presented from, in opposition to the Church of England Property Bill, 560	2	899
HUNTER RIVER DISTRICT (See "CASTINGS FOR HUNTER RIVER DISTRICT").		
HUNTER-STREET NEWCASTLE EXTENSION BILL :—		
Petition presented (<i>Mr. Fletcher</i>) for leave to bring in, 287; leave given, presented, and read 1 ^o , 294; referred to Select Committee, 308; report brought up, 429	2	925
Petition presented (<i>Mr. Ellis</i>) Ratepayers of Newcastle in favour of passing, 325	2	943
Petition presented (<i>Mr. Ellis</i>) Rev. Sydney Calvert Jackson Grime, Frances his wife, William Howard Greenway, and Charles Sweetland against the Bill or to restrict the provisions of, 325	2	941
Petition presented (<i>Mr. Hassall</i>) from Alexander Ogilvie Grant, of Parramatta, against the Bill as it stands, 369	2	945
Petition presented (<i>Mr. Hassall</i>) Alexander Ogilvie Grant, of Parramatta, for leave to appear at the Bar of the House, by Counsel or Attorney, against the Bill, 369	2	947
Petition presented (<i>Mr. Levien</i>) from Alexander Ogilvie Grant, of Parramatta, for leave to appear by Counsel or Attorney before the Select Committee on the Bill, 385; leave granted, 417	2	949
HURSTVILLE (See "RAILWAYS").		
HUSBAND, JAMES H., CLAIM OF :—		
Return to Order (<i>Second Session</i> , 1887), laid on Table, 257	8	1033
HYDRAULIC POWER (See "SYDNEY HYDRAULIC POWER COMPANY'S BILL"; also "SYDNEY AND SUBURBAN HYDRAULIC POWER COMPANY'S BILL").		
I		
IMMIGRATION (See also "STATISTICS"; also "CHINESE") :—		
Report for 1887 laid on Table, 352	2	159
Further Returns to Addresses, laid on Table,—Steamship "Oroya," 6; Steamship "Liguria," 144; Steamship "Orient," 257	2	165, 167 169
CHINESE :—		
Further Correspondence respecting, laid on Table, 369	2	203
Ministerial Statement by Sir Henry Parkes, 364, 451.		
Petition presented (<i>Mr. Haynes</i>) from Chinese residents upon the subject, and read by the Clerk, 454	2	225
Motion made (<i>Mr. Dibbs</i>), (Vote of Censure,) condemning acts of Government in reference to, 468, and negatived, 469.		
IMPERIAL CONFERENCE (See "COLONIAL CONFERENCE IN LONDON, 1887").		
IMPORT DUTIES (See "FINANCE").		
IMPORTED STOCK ACTS :—		
Regulation under, laid on Table, 6 (2), 257, 524	8	637, 639, 641, 651
IMPORTS (See "STATISTICS").		
IMPROVEMENT (See "CROWN LANDS").		
INDUSTRIAL SCHOOL FOR GIRLS, PARRAMATTA :—		
Amended Regulations under Industrial Schools Act of 1866, laid on Table, 155	4	521
INFECTIOUS DISEASES (See "ANIMALS INFECTIOUS DISEASES BILL").		
INFIRM AND DESTITUTE (See "ASYLUMS, GOVERNMENT").		
INLAND WATERS FISHERIES BILL :—		
Motion made (<i>Mr. Tonkin</i>) for leave to bring in, 70; presented and read 1 ^o , 84; read 2 ^o , committed, reported with amendments, and report adopted, 192; read 3 ^o , passed, and sent to Council, 196; returned with amendments, 247; amendments agreed to, 248; Assent reported, 249.		
INSANE :—		
Report of the Inspector-General for 1887, laid on Table, 429	4	635
INSCRIBED STOCK ACT OF 1883 :—		
Fifth Report on the Creation, Inscription, and Issue of Stock under, laid on Table, 257	3	505
INSCRIBED STOCK (See "FINANCE").		
INSOLVENT DEBTOR (See "PRIVILEGE").		
INSOLVENCY (See also "BANKRUPTCY BILL"; also "BANKRUPTCY ACT AMENDMENT BILL") :—		
PETITIONS FOR LEAVE TO SURRENDER ESTATES IN :—		
Motion made (<i>Mr. Cameron</i>) for a return showing number presented since the appointment of Alfred M'Farland, Esq., as Deputy Commissioner, with particulars as to mode of dealing with them, 52.		
INSTRUCTION (See "EDUCATION").		
INTERRUPTION :—		
To debate, 76, 253, 303, 308.		
To Proceedings of the House by interjection by Mr. Thomas Robertson, 79.		
To Proceedings, 296, 349.		
INTOXICATING DRINK :—		
INQUIRY COMMISSION :—		
Report (<i>first part</i>), with Minutes of Evidence and Appendices, laid on Table, 6	7	1
SALE OF, IN PARLIAMENTARY BUILDINGS :—		
Motion made (<i>Mr. Thompson</i>) that the practice of, be at once discontinued, and negatived, 59.		
INVENTIONS :—		
Letters of Registration of, for 1883 and 1884, laid on Table, 191, 420	9	1
INVERELL (See "RAILWAYS"; also "ELECTORATES OF THE GWYDIR AND INVERELL BOUNDARIES AMENDMENT BILL").	10	1
INVESTMENT, BANKING, LAND, AND BUILDING COMPANIES :—		
General Summary of Liabilities and Assets for quarter ended 31st March, 1888, laid on Table, 475	3	849
IRBY, EDWARD. (See "RAILWAYS").		
IRON COVE BRIDGE. (See "BRIDGES").		
IRON AND STEEL RAILWAY AND TRAMWAY MATERIALS (See "RAILWAYS"; also "TRAMWAYS").		
IRON TELEGRAPH POLES (See "TELEGRAPHS").		
IRVING, JAMES (See "CROWN LANDS").		

REFERENCES TO THE VOTES AND PROCEEDINGS, VOL. I—13TH PARLIAMENT—SESSION, 1887-8.	PAPERS.	
	VOL.	PAGE.
J		
JENKINS, MR. L. C. (See "RAILWAYS").		
JOACHIM FAMILY (See "CROWN LANDS"; also "CROWN LANDS PURCHASES VALIDATION BILL").		
JONES, STEPHEN W., ESQ. :— Retirement of, from position of Clerk of Legislative Assembly, 250.		
JUBILEE (See also "ADDRESS"; also "ADELAIDE JUBILEE INTERNATIONAL EXHIBITION") :— COINAGE :— Despatch respecting, laid on Table, 5, 356	8	1,219, 1,221
JUDGES ENABLING BILL :— Received from Legislative Council, and on motion (<i>Mr. Wise</i>) read 1 ^o , 185; Standing Orders suspended, 191; read 2 ^o , committed, reported without amendment, report adopted, read 3 ^o , passed, and returned to Council without amendment, 197.		
JUDGES OF LIVE STOCK (See "RAILWAYS").		
JUDGMENT CREDITORS REMEDIES EXTENSION BILL :— Motion made (<i>Mr. Trickett</i>) for leave to bring in, 58; presented and read 1 ^o , 59; Order of the Day postponed, 107, 147, 151, 234, 416; read 2 ^o , committed, reported without amendment, report adopted, 508; read 3 ^o , passed, and sent to Council, 513; returned without amendment, 626; Assent reported, 630.		
JUVENILE OFFENDERS :— Motion made (<i>Mr. Thompson</i>) for a return, in continuation of a previous one, up to 30th June, 1887, 97; Return to Order, laid on Table, 165	2	707
K		
KAHIBAH (See "CROWN LANDS"; also "MINING").		
KENNY HILL (See "WATER SUPPLY").		
KENT-STREET ROMAN CATHOLIC CHURCH LAND SALE BILL :— Received from Legislative Council, and on motion (<i>Mr. Day</i>) read 1 ^o , 152; motion made for 2 ^o amendment moved to refer to Select Committee and withdrawn, read 2 ^o , committed, reported with amendments and report adopted, 193; read 3 ^o , passed, and returned to Council with amendments, 196; amendments agreed to, 200; assent reported, 237.		
KIAMA (See "ELECTORAL").		
KIAMA TRAMWAY ACT AMENDMENT BILL :— Petition presented (<i>Mr. Cameron</i>), 302; leave given, presented, and read 1 ^o , 307; referred to Select Committee, 314; Report brought up, 369, read 2 ^o , committed, reported without amendment, report adopted, 430; read 3 ^o , passed and sent to Council, 432; returned without amendment, 547; Assent reported, 555.	2	951
KIDMAN & SONS AND JAMES KIDMAN :— Statement of Amount of Money paid to, under various Contracts, from 1876 to 1887 inclusive, laid on Table, (not printed) 403.		
KINGSBURY & CO (See "TELEGRAPHS").		
KURNELL :— PARK RESERVE AT BOTANY BAY :— Motion made (<i>Mr. Carruthers</i>) that immediate steps be taken to secure a sufficient area as, adjacent to the place where Captain Cook first landed in Australia, and withdrawn, 232.		
L		
LABOUR BUREAU, CASUAL :— Return respecting, laid on Table, 35	8	1027
LABOUR HOURS (See "EIGHT HOURS BILL").		
LACHLAN RIVER (See "CONSERVATION OF WATER").		
LAKE MACQUARIE HARBOUR WORKS :— Report (with plans) by Sir John Coode, K.C.M.G., M.I.C.E., laid on Table, 324	3	895
LAND (See also "RAILWAYS"; also "GOVERNMENT"; also "CROWN LANDS") :— PURCHASE BY THE GOVERNMENT OF, BETWEEN A.S.N. CO.'S WHARF AND DAWES POINT :— Motion made (<i>Mr. Melville</i>) for Select Committee to inquire into, Committee appointed by ballot, 30; Report brought up, 305	3	917
Correspondence respecting, laid on Table, and referred to Select Committee, 52	3	1011
Motion made (<i>Mr. Dibbs</i>) for an address to the Governor, censuring Government for, and negatived, 329.		
HELD BY THE HON. JOHN SMITH, IN THE DISTRICT OF MOLONG :— Motion made (<i>Dr. Ross</i>), for a Return showing, under Orders in Council, area of each portion and why granted, 155; Return to Order, laid on Table, 219	5	445
SALE OF IN PARISH OF MOLONG, COUNTY OF ASHBURNHAM :— Motion made (<i>Dr. Ross</i>) for address to Governor for correspondence, plans, Judges decision, and ruling, &c., 479.		
LAND TAX BILL :— Message from Governor, 234, Resolution reported from Ways and Means and agreed to, Ordered (<i>Mr. Burns</i>) founded on Resolution of Ways and Means, presented and read 1 ^o , 430; motion made for 2 ^o and debate adjourned, 496; read 2 ^o and committed, 501; further considered in Committee, 520, 532; further considered, and reported with amendment, 538; report adopted, 544; Order of the Day postponed, 561, 573; amendment negatived to reconsider clauses 1, 2, and 15, recommitted to consider clause 59, 586; further amended, reported 2 ^o , Speaker ruled amendment in order, report adopted, 587; read 3 ^o , passed, and sent to Council, 593.	3	835
Petition from J. C. Neild, Mayor of Woollahra, representing that the provisions in regard to lands held in fee simple and lands held under lease are manifestly inequitable, read by the Clerk, 579.		
LAND TITLES. (See "REAL PROPERTY ACT").	3	837

REFERENCES TO THE VOTES AND PROCEEDINGS, VOL. I—13TH PARLIAMENT—SESSION 1887-8.	PAPERS.	
	VOL.	PAGE.
L		
LANDS FOR PUBLIC PURPOSES ACQUISITION ACT:—		
NOTIFICATIONS OF RESUMPTIONS UNDER, LAID ON TABLE:—		
Public Parks, 6	5.	827
Military Road, South Head to Ben Buckler and Bondi, 22	2	65
Road along Main Sewer to Bondi, from Old South Head Road to Forts at Bondi, 22	5	1019
Public School purposes, 70, 155, 246, 257, 341, 360, 408, 496, 553, 603	4	525 to 545
Water Supply purposes, 5, 165, 613.....	5	871 to 875
Extension of Parramatta Gaol, 231.....	4	1227
Public Cemetery at Singleton, 252	8	1223
Gazette Notice setting forth resumption under 6th section, 314.....	5	683
Daysdale Tank, 415	8	951
Public Wharf near Frederickton, Macleay River, 432	3	1049
Public Wharf near Ghinny Ghinny, Manning River, 475	3	1051
Sydney Sewerage Works, 613.....	5	877
LANDS OFFICE, SYDNEY:—		
Return respecting Tenders for completion of, laid on Table, 635.....	5	99
LANE FAMILY (See "TERALBA COAL-MINING RESERVE").		
LEASEHOLD AREAS (See "CROWN LANDS").		
LEAVE OF ABSENCE:—		
Granted to Member of the Legislative Assembly, 17, 112, 308, 361, 437.		
Do Chairman of Committees, 397, 424.		
LEESON, MR. (See "TELEGRAPHS").		
LEGAL PRACTITIONERS BILL:—		
Motion made (<i>Mr. Walker</i>) for leave to bring in, presented, and read 1 ^o , 128; Order of the Day postponed, 252, 288, 365, 506, 579.		
LEGISLATIVE COUNCIL:—		
Motion made (<i>Mr. Walker</i>) that one Chamber is all that is necessary for the proper transaction of Parliamentary Business, that the Legislative Council is useless and dangerous, and ought to be abolished, and withdrawn, 36.		
LEICHHARDT COUNCIL CHAMBERS (MORTGAGE) BILL:—		
Petition presented (<i>Mr. Hawthorne</i>) for leave to bring in, 107; leave given presented and read 1 ^o 122; referred to Select Committee, 128; Report brought up, 145; read 2 ^o , committed, reported without amendment, and report adopted, 233; read 3 ^o , passed, and sent to Council, 236; returned without amendment, 258; assent reported, 311.	2	957
LEONARD AND BATHGATE'S CANCELED CONTRACTS (See "ROADS").		
LEPROSY AT HONOLULU (See "ADJOURNMENT").		
LETTER SORTERS AND CARRIERS (See "POSTAL").		
LEVIEN MR. :—		
A MEMBER FOR TAMWORTH:—		
Declared guilty of persistent disorder and removed by Sergeant-at-Arms from the Chamber, 221.		
LIBRARY COMMITTEE:—		
Sessional Order passed, 11.		
Name added to, 89.		
LICENSED SURVEYORS:—		
Motion made (<i>Mr. McElhone</i>) for returns of uncompleted instructions in hands of, the names and district, the names of those who employ assistants, the number employed, and the total number employed and unemployed, 378.		
LICENSE FEES (See "CROWN LANDS").		
LICENSES (See also "LOCAL OPTION").		
LICENSING ACT:—		
Motion made (<i>Mr. Jones</i>) for a return showing, revenue derived under from rights granted or penalties inflicted, the annual cost of administration, the annual cost of administration of Justice, the annual cost by reason of the existence of the Liquor Traffic, the number of convictions, and of individuals convicted of drunkenness, 23; Return to Order, laid on Table, 476	7	679
EMPLOYMENT OF BARMAIDS IN PUBLIC HOUSES:—		
Petition from Women's Christian Temperance Union and others, to amend the law so as to prohibit, presented, 22.	7	711
PRIVATE BARS IN PUBLIC HOUSES:—		
Motion made (<i>Mr. Henson</i>) that the system of, is an evil, the Government should at once take steps to suppress; Previous Question moved and negatived, 165.		
CONVICTIONS UNDER:—		
Motion made (<i>Mr. Henson</i>) for additional information, 506.		
Spirits, wines, and beer—Annual Return to Order, laid on Table, 560.	7	681
LIENS ON WOOL BILL:—		
Motion made (<i>Mr. J. P. Abbott</i>) for a Committee of the Whole, 40; Order of the Day postponed, 65; House in Committee and Resolution agreed to, 107;		
LIGHTERING, DELIVERING, AND STORING OF EXPLOSIVES:—		
Amended Rates and Charges for, laid on Table, 280.....	8	1207
LIGHTHOUSE (See "MACQUARIE LIGHTHOUSE").		
LIMITED EXPRESS TRAIN (See "RAILWAYS").		
LIQUOR (See "COMMISSION;" also "LICENSING ACT").		
LIQUOR TRAFFIC (LOCAL VETO) BILL:—		
Motion made (<i>Mr. Hutchinson</i>) for leave to bring in, 344; presented and read 1 ^o , 345; Order of the Day discharged, 389.		
PETITIONS PRESENTED, representing that enormous evils everywhere result from the traffic in intoxicating liquors, and praying the House to pass the Bill:—		
From Alexander Gow, Chairman of Local Option League, 386		695
"Light of the Valley" Lodge, Lithgow, 432		
"Excelsior Lodge," No. 279, Jamboeroo, 432		697
"Beacon of Light" Lodge, Wollongong, 432		
"Miners' Friend" Lodge, Fairy Meadow, 432.....		
"Northern Star" Lodge, Lismore, 451		
"Hope to Save" Lodge, Lismore, 451		
"Pride of the Richmond" Lodge, Rous, 451	7	
"Minnehaha" Lodge, Lismore, 451		
"Victoria" Lodge, Armidale, 451		699
"Hope of Saumarez" Lodge, Saumarez Ponds, 451		
"Lachlan" Lodge, Forbes, 451		
"Hopeful" Lodge, Condobolin, 451		

REFERENCES TO THE VOTES AND PROCEEDINGS, VOL. I—13TH PARLIAMENT—SESSION 1887-8.		PAPERS.	
		VOL.	PAGE.
L			
LIQUOR TRAFFIC (LOCAL VETO) BILL—(continued) :—			
PETITIONS PRESENTED—(continued) :—			
From "Guiding Star" Lodge, Wellington, 451		7	699
Public Meeting of Residents in and about Balmain, 451			
"Alexander Hutchison" Lodge, Newcastle, 451			
"W. S. Reay" Lodge, Bredalbane, 454			
"Evening Star" Lodge, Parramatta, 462			
"Rock of Refuge" Lodge, Maclean, Clarence River, 462			
No. 96 Lodge, Milton, 462			
"Pride of Austinmer" Lodge, Austinmer, 462			
"Happy Dawn" Lodge, Araluen, 462			
Certain residents of Tingha, 467			
"Flower of the Forest" Lodge, Kangaloon, 467			
"Enemy of Alcohol" Lodge, Werombi, near Camden, 467			
"Sherwood Rangers" Lodge, Goughtown, 467			
"Temple of Good Hope" Lodge, Tenterfield, 467			
"Princess Beatrice" Lodge, Newtown, 467			
"Rescue" Lodge, Parkes, 467			
"Pride of Rooty Hill" Lodge, Rooty Hill, 467			
"Union is Strength" Lodge, Wiseman's Creek, 467			
"Hearts of Oak" Lodge, Waverley, 467			
"Alexandria" Lodge, St. Mark's, Darling Point, 467			
"Southern Cross" Division, Kiama, 467			
Certain residents of Wagga Wagga and surrounding Districts, 467			
"Try Again" Lodge, Hillston, 467			
"Ark of Refuge" Lodge, Cobar, 467			
"Union of the East" Lodge, Eastgrove, Goulburn, 467			
"Eureka" Lodge, Gunning, 467			
"Hope of Wilcannia" Lodge, Wilcannia, 467			
"Golden Chain" Lodge, Petersham, 467			
"Dawn of Day" Lodge, Goulburn, 467			
"Reunion" Lodge, Upper Botany, 475			
"Star of the South" Lodge, Cooma, 475			
"Hope of Walcha" Lodge, Walcha, 475			
"Hope of Hastings" Lodge, Port Macquarie, 475			
"Haste to the Rescue" Lodge, Balmain, 475			
"Excelsior" Lodge, Clarence Town, 475			
"Pride of Bungawalbyn" Lodge, Bungawalbyn, 475			
"Wardell Hope" Lodge, Wardell, 475			
"Star of Hope" Lodge, Chatsworth, Clarence River, 475			
"Rose of Dryaba" Lodge, Lawrence, Clarence River, 475			
"Pride of Minmi" Lodge, Minmi, 475			
"Perseverance" Lodge, Hay, 475			
"Unity" Lodge, St. Paul's, Redfern, 475			
"Victoria" Lodge, Collector, 478			
"Joseph Livesay" Lodge, Randwick, 478			
"Friendship Division," No. 10, Lismore, 478			
"Centennial" Lodge, Marulan, 478			
"Universal" Lodge, Castle Hill, 478			
"Star of the East" Lodge, Field of Mars, 478			
"Harvest Home" Lodge, Tamworth, 478			
"Hope of Coolangatta" Lodge, Coolangatta, Shoalhaven, 484			
"Star of Moruya" Lodge, Moruya, 484			
"Hope of Molong" Lodge, Molong, 492			
The "W. E. Gladstone" Lodge, Mount Keira, 492			
"Glen Morrison" Lodge, Glen Morrison, 492			
"Star of Young" Lodge, Young, 492			
"Pride of Moss Vale" Lodge, Moss Vale, 492			
"Hope of Bundanoon" Lodge, Bundanoon, 492			
"Gordon" Lodge, Bowral, 492			
"Rose of Marrickville" Lodge, Marrickville, 492			
"Life Buoy" Lodge, Gundurimba, 492			
"Star of Oberon" Lodge, Oberon, 493			
"Want Supplied" Lodge, Bingera, 493			
"Currabubula United" Lodge, Currabubula, 493			
Good Templars, Walgett, 496			
"Olive Branch" Lodge, Kinchela, 500			
"Ark of Safety" Lodge, Orange, 560			
"Star of Peace" Lodge, Spring Terrace, 560			
Public Meeting held in Bathurst, 538			
LISMORE (See also "CROWN LANDS") :—			
WATER SUPPLY :—			
Notification of resumption of certain land, required in connection with the construction of works for, 5		5	871
LISTER J. H. A. (See "MINING").			
LITTLE BAY (See "COAST HOSPITAL, LITTLE BAY.")			
LIVERPOOL CHURCH OF ENGLAND GRAMMAR SCHOOL LAND SALE BILL :—			
Petition presented (<i>Mr. Nobbs</i>) for leave to bring in, 386; leave given, presented, and read 1 ^o , 389; referred to Select Committee, 397; report brought up, 409; Order of the Day postponed, 479, 593, 608, 613, 619.		2	965
LIVERPOOL-ST. PETER'S LINE (See "RAILWAYS").			
LIVE STOCK :—			
Return of, in Australasian Colonies, 1871, 1881, and 1887, laid on Table, 565		8	597
LOAN ESTIMATES (See "FINANCE").			
LOANS (See "FINANCE," also "MUNICIPAL LOANS BILL," also "REPAYMENT OF LOANS BILL," also "PUBLIC WORKS LOAN BILL").			
LOCAL AND NATIONAL WORKS :—			
Statement of Expenditure on, in the Colony, from 1860 to 1886, laid on Table, 28		8	1231
LOCAL GOVERNMENT BILL (See "DISTRICT GOVERNMENT BILL").			

REFERENCES TO THE VOTES AND PROCEEDINGS, VOL. I—13TH PARLIAMENT—SESSION, 1887-8.	PAPERS.	
	VOL.	PAGE.
L		
LOCAL OPTION (See also "LIQUOR TRAFFIC (LOCAL VETO) BILL"). Motion made (<i>Mr. Hutchison</i>) that a legal power of restraining the issue or renewal of licenses should be placed in the hands of those most interested, who are entitled to protection from injurious consequences of the present system by some efficient measure of, 24; Petition that a veto power as to granting new licenses or the renewal of old ones be conceded in any amending Licensing Act, presented, 35	7	693
VOTE IN METROPOLITAN AND SUBURBAN MUNICIPALITIES :— Return showing result of, taken in February, 1888, laid on Table, 524	7	689
LOCOMOTIVE ENGINES (See "RAILWAYS").		
LODGING-HOUSES BILL (See "COMMON LODGING-HOUSES BILL").		
LUCAS, SURVEYOR, CHARGES AGAINST :— Motion made (<i>Mr. McElhone</i>) for papers in connection with, 578.		
LYNE MR. :— A MEMBER FOR THE HUME :— Declared guilty of persistent disorder and removed by Sergeant-at-Arms from the Chamber, 221.		
M		
MACGREGOR, WILLIAM PETER, ESQ., M.P. :— Resignation of, as a Member for Wentworth, reported, 1.		
MACKRELL, ROBERT. CONDITIONAL PURCHASE OF (See "CROWN LANDS").		
MACLEAN (See PRESBYTERIAN CEMETERY AT MACLEAN").		
MACQUARIE LIGHTHOUSE :— ELECTRIC LIGHTING :— Motion made (<i>Mr. Wall</i>) for correspondence between the Colonial Architect and the Superintendent of Telegraphs, 267; Return to Order, laid on Table, 543	4	1199
MAIL COMMUNICATION BETWEEN GREAT BRITAIN AND AUSTRALIA VIA SUEZ (See "POSTAL").		
MALONEY, MARY (See "CROWN LANDS").		
MANLY DRAINAGE WORKS (See "PARLIAMENTARY STANDING COMMITTEE ON PUBLIC WORKS").		
MANLY TRAMWAY BILL (See "NORTH SHORE, MANLY, AND PITFWATER TRAMWAY AND RAILWAY BILL").		
MANNING, MR., CORONER, AT RYDE (See "ADMINISTRATION OF JUSTICE").		
MANSFIELD, JOHN :— Report and evidence in connection with the Fatal Accident to, at the Northumberland colliery, 475	8	249
MANUFACTORIES (See also "STATISTICS"). IMPORT DUTIES ON ARTICLES LOCALLY MANUFACTURED :— Motion made (<i>Mr. Copeland</i>) for, and on agricultural productions grown in the Colony, and the Question not being put at 7 o'clock, Government business takes precedence, 493.		
MARKETS (See "FOREIGN MARKETS FOR WOOL AND MEAT").		
MARKS (See "MERCHANDISE MARKS BILL").		
MASTERS AND MATES :— Despatch respecting Applications for Certificate of Competency, laid on Table, 475	8	1015
MAXWELL ANN (See "ADMINISTRATION OF JUSTICE").		
MAYORAL ELECTION (See "CITY OF SYDNEY MAYORAL ELECTION BILL").		
MCBEAN JOHN (See "MINING").		
MCCARRAN, EDWARD :— Report and evidence in connection with the Fatal Accident to, at the West Wallsend colliery, laid on Table, 475	8	259
MCCULLOCH, ANDREW HARDIE, JUN., ESQ., M.P. :— Resignation of, as a Member for Central Cumberland reported, and seat declared vacant, 222, 419; issue and return of Writ reported, 249, 463; sworn, 253.		
MCDELHONE, JOHN, ESQ., M.P. :— Words of heat used by, withdrawn and apology made, 374. Disorderly words used by, reported from Committee of Supply, 452. Disorderly words used by, reported from Committee of Whole, 479; Ordered to attend in his place, Sergeant reported that after diligent search he had failed to find the Hon. Gentleman on the premises, committed to custody of Sergeant-at-Arms for contempt, and Speaker's warrant issued, 480; reported as in custody of Sergeant-at-Arms, 483; motion made in reference to discharging the Honorable Member from custody, Hon. Member admitted to Bar and made explanation and apology, and discharge authorized, Speaker directed Sergeant accordingly, 485, 496.		
MCINTOSH EVAN, CONDITIONAL PURCHASE OF (See "CROWN LANDS").		
MCIVOR MATTHEW (See "MINING").		
McKINLAY, JOSEPH FRANCIS (See "MINING").		
MCNEILL, MESSRS. HUGH, AND PARTY (See "MINING").		
McSHARRY AND O'ROURKE (See "RAILWAYS").		
MEAT (See DISEASED ANIMALS AND MEAT BILL).		
MEDICAL ATTENDANCE (See "DEDUCTIONS FROM WAGES OF EMPLOYEES FOR MEDICAL ATTENDANCE").		
MEDICAL PRACTITIONERS (See "REGISTERED MEDICAL PRACTITIONERS BILL").		
MEDICINE AND SURGERY :— Motion made (<i>Mr. Melville</i>) for Select Committee to inquire into practice, law, and regulation of, 58.		
MEETING OF THE HOUSE :— Sessional Order passed, 10.		
Hour of :— Motion made (<i>Mr. Seaver</i>) that during remainder of Session, House meet at 4 o'clock instead of 3 o'clock as at present, and negatived, 224.		
MELBOURNE EXHIBITION (See "CENTENNIAL INTERNATIONAL EXHIBITION, MELBOURNE").		
MELVILLE, NINIAN, Esq., M.P. :— A MEMBER FOR NORTHUMBERLAND :— "Named" by Mr. Speaker for refusing to withdraw and apologize for words ruled as out of order, withdrew words and apologized, 184. Declared guilty of persistent disorder and removed by Sergeant-at-Arms from the Chamber, 220. Motion made for adjournment of House to consider attack on, by <i>Sydney Morning Herald</i> , 335. Appointed with three others to act temporarily as Chairman of Committees in the absence of the Member appointed to that office, 389. Mr. Speaker calls on, to act as Deputy Chairman for this day only, 397, 416, 429, 442, 451, 463, 479, 496, 506, 532, 543, 547, 560.		

REFERENCES TO THE VOTES AND PROCEEDINGS, VOL. I—13TH PARLIAMENT—SESSION, 1887-8.	PAPERS.	
	VOL.	PAGE.
M		
MEMBERS (See also "PAYMENT OF MEMBERS OF THE LEGISLATIVE ASSEMBLY"; also "ASSEMBLY"; also "PARLIAMENTARY REPRESENTATIVES ALLOWANCE BILL") :—		
Sworn, 76, 87, 249, 253 ⁽²⁾ , 303, 342, 463.		
Of Elections and Qualifications Committee sworn, 37 ⁽¹⁾ .		
Leave of absence granted to, 17, 112, 308, 361, 437.		
"Named" by Mr. Speaker, 156 ⁽²⁾ , 184.		
Suspended for remainder of Sitting, 345.		
Motion made for, to be heard, 302 ⁽²⁾ .		
Name added to Select Committee, 89, 280.		
Name discharged from Select Committee, 432, 462.		
Declared guilty, of persistent disorder, and removed from Chamber, 220 ⁽¹⁾ , 221 ⁽¹⁾ .		
<i>Words of heat</i> , used by, 374.		
Motion made (<i>Mr. Melville</i>) for adjournment of House to consider an attack made in an article in the <i>Sydney Morning Herald</i> on an Honorable Member for Northumberland, 334.		
Committed to custody of Sergeant-at-Arms by Speaker's warrant, 480.		
In custody of Sergeant-at-Arms, 483.		
Discharged from custody, 486.		
Name substituted for another on Select Committee, 585.		
Attendance of, in Divisions and Counts-out	1	653
MENINDIE (See "BRIDGES").		
MENMUIR, S.S. :—		
Return respecting Chinese passengers by, laid on Table, 454.	2	211
MERCANTILE BROKERS :—		
Petition from Merchants and, praying to be regulated by enactment by issue of licenses, presented, 224.	8	1225
MERCHANDISE MARKS BILL :—		
Motion made (<i>Mr. Wise</i>) for Committee of the Whole, 352. Order of the Day postponed, 508.		
MESSAGES :—		
TRANSMISSION OF, BETWEEN THE TWO HOUSES :—		
Sessional Order passed, 11.		
FROM THE GOVERNOR :—		
Delivered by Usher of the Black Rod, 1, 642.		
1. Assent to Saint James Parsonage Land Leasing Bill (<i>passed in last Session</i>), 2.		
2. Bankruptcy Bill, 2.	2	729
3. District Government Bill, 34.	2	569
4. Government Railways Bill, 35.	6	1105
5. Crown Lands Bill, 49.	5	599
6. Supreme Court Appeals Act Amendment Bill, 135.	2	733
7. Public Works Bill, 135.	8	1259
8. Naval Force (Australasian Naval Force Bill), 157.	2	67
9. Crown Lands Bill (No. 2), 162.	5	603
10. Mining on Church and School Lands, 166.	8	541
11. Assent to Supreme Court Appeals Act Amendment Bill, 168.		
12. Assent to Church and Perkins Streets (Newcastle) Bill, 171.		
13. Assent to Borough of Balmain Wharves Bill, 171.		
14. Estimates of Expenditure for 1888 and Supplementary Estimates for 1887 and previous years, 200.	3	1
15. Assent to Bankruptcy Bill, 219.		
16. Assent to Royalty on Oysters Abolition Bill, 219.		
17. Assent to Municipal Roads and Streets Bill, 219.		
18. Assent to Country Towns Water and Sewerage Act Extension Bill, 219.		
19. Assent to Albury Cattle Sale-yards Bill, 219.		
20. Metropolitan Water and Sewerage Act Amendment Bill, 228.	5	879
21. Land Tax, 234.	3	835
22. Property Tax, 234.	3	839
23. Assent to Australasian Naval Force Bill, 237.		
24. Assent to Kent-street Roman Catholic Church Land Sale Bill, 237.		
25. Assent to Yass Roman Catholic Church Land Sale Bill, 239.		
26. Vote of Credit 241.	3	821
27. do (January), 241.	3	823
28. Assent to Inland Waters Fisheries Bill, 249.		
29. Assent to Consolidated Revenue Fund Bill, 250.		
30. Assent to Sydney Corporation Act Amendment Bill, 250.		
31. Assent to Wentworth Electorate Subdivision Bill, 250.		
32. Rabbit Pest Suppression Bill, 268.	8	981
33. Parliamentary Representatives Allowances Bill, 268.	1	885
34. Vote of Credit, 285.	3	825
35. Assent to Consolidated Revenue Fund Bill, 311.		
36. Assent to Leichhardt Council Chambers (Mortgage) Bill, 311.		
37. Animals Infectious Diseases Bill, 314.	8	665
38. Assent to Metropolitan Water and Sewerage Act Amendment Bill, 317.		
39. Assent to Conversion into Mining Conditional Purchases Validation Bill, 317.		
40. Vote of Credit, 315.	3	827
41. Assent to Consolidated Revenue Fund Bill (No. 3), 351.		
42. Mail Service between Great Britain and Australia, <i>via</i> Suez, 355.	4	1109
43. Assent to Animals Infectious Diseases Bill, 378.		
44. Formation of street north of the General Post Office, 383.	4	1141
45. Vote of Credit, 404.	3	829
46. Assent to Consolidated Revenue Fund Bill (No. 4), 419.		
47. Assent to Victorian Coal-mining Company's Extension Bill, 419.		
48. Circular Quay Land Sale and Dedication Bill, 420.	3	1019
49. Assent to Tattersall's Club Bill, 435.		
50. Chinese Restriction and Regulation Bill, 454.	2	227
51. Assent Government Railways Bill, 461.		
52. Assent to Distribution of Funds in Sempill's Estates Bill (No. 2), 461.		
53. Assent to Christian Chapel Lands Sale Bill, 461.		
54. Assent to Rockdale Municipality Naming Bill, 462.		
55. Vote of Credit, 477.	3	831
56. Amended Estimates for Departments under control of Colonial Secretary, 491.	3	259

REFERENCES TO THE VOTES AND PROCEEDINGS, VOL. I—13TH PARLIAMENT—SESSION 1887-8.	PAPERS.	
M	VOL.	PAGE.
MESSAGES—(continued) :—		
FROM THE GOVERNOR—(continued) :—		
57. Assent to Consolidated Revenue Fund Bill, 491.		
58. Assent to Public Works Bill, 492.		
59. Assent to Readhead Coal Mine Railway Act Extension Bill, 492.		
60. Assent to Australian Mutual Provident Society's Acts Amendment Bill, 524.		
61. Government Railways Act Amendment Bill, 539	6	1107
62. Diseased Animals and Meat Bill, 539	8	667
63. Assent to St. Thomas Church (Enfield) Lands Sale Bill, 539.		
64. Assent to Permanent Trustee Company of New South Wales Bill, 539.		
65. Assent to Vine Diseases Act Amendment, 540.		
66. Amended Estimates for Departments under control of Colonial Secretary, 545	3	295
67. Vote of Credit, 553	3	333
68. Assent to Consolidated Revenue Fund Bill (No. 6), 555.		
69. Assent to Contractors' Debts Act Amendment Bill, 555.		
70. Assent to Kiama Tramway Act Amendment Bill, 555.		
71. Assent to Perpetual Trustee Company Bill, 555.		
72. Assent to Chinese Restriction and Regulation Bill, 585.		
73. Further Supplementary Estimates for 1887, and Additional Estimate for 1888, 610	3	331
74. Further Additional Estimate for 1888, 610	3	353
75. Additional Estimate on Account of Repayment of Loans, 610	3	359
76. Loan Estimate for 1888, 610	3	365
77. Assent to Government Railways Act Amendment Bill, 619.		
78. Assent to Criminal Law Amendment Bill, 626.		
79. Assent to Parramatta Church-street Amended Alignment Bill, 629.		
80. Assent to Circular Quay Land Sale and Dedication Bill, 629.		
81. Assent to Bankruptcy Act Amendment Bill, 629.		
82. Assent to Church and Schools Lands Mining Bill, 629.		
83. Assent to Crown Lands Purchases Validation Bill, 630.		
84. Assent to Companies Bill, 630.		
85. Assent to Municipal Loans Bill, 630.		
86. Assent to Judgment Creditors' Remedies Extension Bill, 630.		
87. Assent to Crown Lands Act Further Amendment Bill, 630.		
FROM ASSEMBLY TO COUNCIL :—		
Transmitting		
Sydney Corporation Act Amendment Bill, 48.		
Municipal Roads and Streets Bill, 49.		
Albury Cattle Sale Yards Bill, 49.		
Borough of Balmain Wharves Bill, 64.		
Bankruptcy Bill, 107.		
Country Towns Water and Sewerage Act Extension Bill, 1		
Church and Perkins Streets (Newcastle) Bill, 112.		
Wentworth Electorate Sub-division Bill, 136.		
Supreme Court Appeals Act Amendment Bill, 145.		
Yass Roman Catholic Church Land Sale Bill, 150.		
Royalty on Oysters Abolition Bill, 169.		
Inland Waters Fisheries Bill, 196.		
Rockdale Municipality Re-naming Bill, 208.		
Australasian Naval Force Bill, 210.		
Transmitting Metropolitan Water and Sewerage Act Amendment Bill, 232.		
Leichhardt Council Chambers (Mortgage Bill), 236.		
North Shore, Manly, and Pittwater Tramway and Railway Bill, 236.		
Victorian Coal-mining Company's Extension Bill, 237.		
Consolidated Revenue Fund Bill, 242.		
Government Railway Bills, 258.		
Conversion into Mining Conditional Purchases Validation Bill, 263.		
Consolidated Revenue Fund Bill (No. 2), 296.		
Redhead Coal-mine Railway Act Extension Bill, 325.		
Animals Infectious Diseases Bill, 335.		
Consolidated Revenue Fund Bill, 346.		
Distribution of Funds in Sempill's Estates Bill, 373.		
Public Works Bill, 380.		
Christian Chapel Lands Sale Bill, 389.		
Consolidated Revenue Fund Bill (No. 4), 409.		
Vine Diseases Act Amendment Bill, 422.		
Silverton Tramway Act Amending Bill, 425.		
Kiama Tramway Act Amendment Bill, 432.		
Chinese Restriction and Regulation Bill, 456.		
Consolidated Revenue Fund Bill (No. 5), 481.		
Companies Bill, 512.		
Divorce Extension Bill, 512.		
Bills of Sale Act Amending Bill, 513.		
Broken Hill and Suburban Gas Company's Bill, 513.		
Contractors Debts Act Extension Bill, 513.		
Judgment Creditors Remedies Extension Bill, 513.		
Parliamentary Representatives Allowance Bill, 549.		
Consolidated Revenue Fund Bill, 554.		
Crown Lands Purchases Validation Bill, 560.		
Circular Quay Land Sale and Dedication Bill, 567.		
Essex-street Alignment Bill, 567.		
Government Railways Act Amendment Bill, 573.		
Church and School Lands Mining Bill, 585.		
Land Tax Bill, 593.		
Crown Lands Act Further Amendment Bill, amendment proposed to add words to and negatived, 595.		
Bankruptcy Act Amendment Bill, 598.		
Parramatta Municipal Quarries Bill, 601.		
Parramatta Church-street Amended Alignment Bill, 602.		
Cooma Church of England Lands Sale Bill, 602.		
Municipal Loans Bill, 602.		
Appropriation Bill, 639.		
Repayment of Loans Bill, 640.		
Public Works Loans Bill, 640.		

REFERENCES TO THE VOTES AND PROCEEDINGS, VOL. I—13TH PARLIAMENT—SESSION, 1887-8.	PAPERS.
M	VOL. PAGE.
MESSAGES (<i>continued</i>):—	
FROM ASSEMBLY TO COUNCIL—(<i>continued</i>):—	
Returning Kent-street Roman Catholic Church Land Sale Bill, with amendments, 196.	
Judges Enabling Bill, without amendment, 197.	
Tattersall's Club Bill, 425.	
Perpetual Trustee Company Bill, with amendments, 505.	
Permanent Trustee Company of New South Wales Bill, without amendment, 524.	
St. Thomas Church (Enfield) Lands Sale Bill, without amendment, 524.	
Australian Mutual Provident Society's Acts Amendment Bill, without amendment, 512.	
Criminal Law Amendment Bill, without amendment, 598.	
Agreeing to amendments in Borough of Balmain Wharves Bill, 162.	
Municipal Roads and Streets Bill, 192.	
Sydney Corporation Act Amendment Bill, 243.	
Wentworth Electorate Subdivision Bill, 243.	
Inland Waters Fisheries Bill, 248.	
Metropolitan Water and Sewerage Act Amendment Bill, 308.	
Conversion into Mining Conditional Purchases Validation Bill, 309.	
Rockdale Municipalities Naming Bill, 417.	
Distribution of Funds in Sempill's Estate Bill (No. 2), 429.	
Public Works Bill, including an amendment in the Title, 463.	
Redhead Coal Mine Railway Act Extension Bill, 464.	
Vine Diseases Act Amendment Bill, 494.	
Circular Quay Land Sale and Dedication Bill, 626	
Bankruptcy Act Amendment Bill, 627.	
Church and School Lands Mining Bill, 627.	
Crown Lands Purchases Validation Bill, 627.	
Companies Bill, 628.	
Silverton Tramway Act Amending Bill, 641.	
Cooma Church of England Lands Sale Bill, 641.	
Agreeing and disagreeing to amendments in Bankruptcy Bill, 174.	
Agreeing to amendments with amendments, in the Albury Cattle Sale Yards Bill, 197.	
Agreeing to, disagreeing to, amending and agreeing to, amendments in Government Railways Bill, 390.	
Agreeing to amendments made in the Victorian Coal-mining Company's Extension Bill, 410.	
Agreeing to amendment and not insisting upon disagreement to amendment in Government Railway Bill, 426.	
Agreeing to some, disagreeing to others, including an amendment in the Title, and amending others of the amendments in the Chinese Restriction and Regulation Bill, 531.	
Not insisting on disagreements from Council's amendments, nor upon Assembly's amendments, in the Chinese Restriction and Regulation Bill, 573.	
FROM COUNCIL TO ASSEMBLY:—	
Transmitting Perpetual Trustee Company Bill, 98.	
Australian Mutual Provident Society's Acts Amendment Bill, 326.	
Tattersall's Club, 346.	
Kent-street Roman Catholic Church Land Sale Bill, 152.	
Judges Enabling Bill, 185.	
Bulli Colliery Disaster Fund Bill, 398.	
Criminal Law Amendment Bill, 430.	
Church of England Property Bill, 455.	
St. Thomas Church, Enfield, Lands Sale Bill, 462.	
Permanent Trustee Company of New South Wales Bill, 462.	
Factories and Workshops Bill, 614.	
Returning Municipal Roads and Streets Bill, with amendments, 71.	
Albury Cattle Sale Yards Bill, with amendments, 113.	
Borough of Balmain Wharves Bill, with amendments, 151.	
Consolidated Revenue Fund Bill (No. 2.) without amendment, 308.	
Animals Infectious Diseases Bill, 338.	
Church and Perkins Streets (Newcastle) Bill, without amendment, 152.	
Supreme Court Appeals Act Amendment Bill, without amendment, 157.	
Bankruptcy Bill, with amendments, 158.	
Country Towns Water and Sewerage Act Extension Bill, without amendment, 177.	
Royalty on Oysters Abolition Bill, without amendment, 197.	
Yass Roman Catholic Church Land Sale Bill, without amendment, 210.	
Wentworth Electorate Subdivision Bill, with amendments, 210.	
Sydney Corporation Act Amendment Bill, with amendments, 229.	
Australasian Naval Force Bill, without amendment, 230.	
Inland Waters Fisheries Bill, with amendments, 247.	
Consolidated Revenue Fund Bill, without amendment, 247.	
Leichhardt Council Chambers (Mortgage) Bill, 258.	
Returning Rockdale Municipality Re-naming Bill, with amendments, 264.	
Metropolitan Water and Sewerage Act Amendment Bill, with amendments, 281.	
Conversion into Mining Conditional Purchases Validation Bill, with amendment, 281.	
Consolidated Revenue Fund Bill (No. 3), 349.	
Government Railways Bill, with amendments, 378.	
Redhead Coal-mine Railway Act Extension Bill, with amendments, 390.	
Distribution of Funds in Sempill's Estates Bill (No. 2), with amendments, 398.	
Consolidated Revenue Fund Bill (No. 4), without amendment, 416.	
Victorian Coal-Mining Company's Extension Bill, with amendments, 410.	
Christian Chapel Lands Sale Bill, without amendment, 426.	
Vine Diseases Act Amendment Bill, with amendments, 442.	
Public Works Bill, with amendments, 442.	
Consolidated Revenue Fund Bill (No. 5), without amendment, 486.	
Chinese Restriction and Regulation Bill, with amendments, 514.	
Kiama Tramway Act Amendment Bill, without amendment, 547.	
Contractors Debts Act Extension Bill, without amendment, 547.	
Consolidated Revenue Fund Bill (No. 6), without amendment, 554.	
Circular Quay Land Sale and Dedication Bill, with an amendment, 613.	
Bankruptcy Act Amendment Bill, with an amendment, 614.	
Church and Schools Lands Mining Bill, with an amendment, 615.	
Crown Lands Act Further Amendment Bill, without amendment, 626.	
Judgment Creditors Remedies Extension Bill, without amendment, 626.	
Government Railways Act Amendment Bill, without amendment, 593.	

REFERENCES TO THE VOTES AND PROCEEDINGS, VOL. I—13TH PARLIAMENT—SESSION, 1887-8.	PAPERS.	
M	VOL.	PAGE.
MESSAGES—(continued) :—		
FROM COUNCIL TO ASSEMBLY—(continued) :—		
Returning Silverton Tramway Act Amending Bill, with amendments, 593.		
Crown Lands Purchases Validation Bill, with an amendment, 594.		
Companies Bill, with an amendment, 594.		
Parramatta Church-street Amended Alignment, Bill, without amendment, 626.		
Municipal Loans Bill, without amendment, 626.		
North Shore, Manly, and Pittwater Tramway and Railway Bill, with amendments, 635.		
Divorce Extension Bill, with amendments, 638.		
Cooma Church of England Lands Sale Bill, with amendments, 639.		
Appropriation Bill, without amendment, 642.		
Repayment of Loans Bill, without amendment, 642.		
Public Works Loan Bill, without amendment, 642.		
Not insisting upon its amendments disagreed to in Bankruptcy Bill, 185.		
Agreeing to amendments upon amendments in Albury Cattle Sale-Yards Bill, 200.		
Agreeing to amendments in Kent-street Roman Catholic Church Land Sale Bill, 200.		
Not insisting on their amendment, but proposing one in lieu thereof, agreeing to amendment made by Assembly on their amendments and insisting on amendment and not insisting on amendment, in Government Railways Bill, 417.		
Agreeing to amendments made in the Perpetual Trustee Company Bill, 538.		
Insisting on some of its amendments, and does not insist on others, in the Chinese Restriction and Regulation Bill, 566.		
METROPOLITAN FIRE BRIGADES ACT OF 1884 :—		
Report of Fire Brigades Board for 1887, laid on Table, 378	2	571
METROPOLITAN TRANSIT COMMISSIONERS :—		
Information respecting, laid on Table, 385	2	291
METROPOLITAN WATER AND SEWERAGE ACT AMENDMENT BILL :—		
Motion made (<i>Sir Henry Parkes</i>) for Committee of the Whole, 196; House in Committee and resolution agreed to, 201; presented and read 1 ^o , 224; Message from Governor, 228; read 2 ^o , committed, reported with an amendment, and report adopted, 228; read 3 ^o , passed and sent to Council, 232; returned with amendments, 281; amendments agreed to, 308; assent reported, 317.	5	879
METZ (See "MINING").		
MIDNIGHT :—		
Sittings after, 4, 30, 53, 65, 77, 90, 99, 115, 119, 123, 136, 140, 146, 152, 162, 169, 186, 198, 210, 220, 242, 248, 264, 288, 296, 304, 329, 345, 361, 374, 381, 390, 422, 425, 430, 434, 442, 452, 452, 455, 469, 476, 480, 487, 494, 496, 501, 509, 514, 520, 526, 538, 544, 548, 554, 574, 580, 587, 603, 615, 619, 628, 639.		
MILITARY :—		
OFFICERS OF PERMANENT AND VOLUNTEER CORPS :—		
Return to Order (<i>Second Session 1887</i>), laid on Table, 6	2	13
ROAD, SOUTH HEAD TO BEN BUCKLER AND FORTS, BONDI :—		
Notification under Lands for Public Purposes Acquisition Act of resumption of land for, laid on Table, 22	2	65
MAJOR PARROTT'S REPORT :—		
Motion made (<i>Mr. Dibbs</i>) that this House do now adjourn to consider answer to a question in reference to, and negatived, 64.		
Correspondence respecting, on Coast and Harbour Defence, laid on Table, 84	2	63
CASE OF DANIEL BEHAN :—		
Motion made (<i>Mr. Alfred Allen</i>) for a Select Committee to inquire into discharge of, late a Sergeant in the New South Wales Artillery, 71; name added to Committee, 89.		
DEFENCES OF NEW SOUTH WALES :—		
Report of Major-General Schaw on, laid on Table, 199	2	47
CAPTAIN A. H. P. SAVAGE, PERMANENT ARTILLERY :—		
Motion made (<i>Mr. Wail</i>) for papers relative to appointment of, as Captain, 320; Return to Address laid on Table, 334	2	11
ORDERLY CLERKS EMPLOYED IN THE BRIGADE OFFICE :—		
Return showing number for last twelve months, laid on Table, 334	2	29
FORCES OF THE COLONY :—		
Annual Report for 1887 laid on Table, 425	2	1
ENGAGEMENT OF IMPERIAL OFFICER :—		
Correspondence respecting, laid on Table, 479	2	7
AMMUNITION :—		
Correspondence respecting Establishment of Manufactory, laid on Table, 479	2	41
FREE RAILWAY PASSES :—		
Return respecting issued by the Staff Office of Volunteers, &c., during quarter ended 30 June, 1888, laid on Table, 524	2	25
FRENCH POSTS IN THE NEW HEBRIDES :—		
Correspondence respecting evacuation of, laid on Table, 529	8	1231
BRIGADE OFFICE ACCOUNTS :—		
Return respecting, laid on Table, 578	2	25
MILLAUR, THOMAS (See "CROWN LANDS PURCHASES VALIDATION BILL").		
MILLGATE, GEORGE (See "CROWN LANDS").		
MILLPARINKA (See "TELEGRAPHS").		
MINERALS (See "MINING").		
MINERS' RIGHTS (See "MINING").		
MINING (See also "CHURCH AND SCHOOLS LANDS MINING BILL") :—		
APPLICATIONS FOR MINERAL CONDITIONAL PURCHASES, PARISH OF METZ :—		
Further Return (<i>in part</i>) to an Order (<i>Second Session 1887</i>), laid on Table, 6; Referred to Select Committee, on same subject, 463	8	459
Motion made (<i>Mr. Levien</i>) for a Select Committee to inquire into and report upon the granting of to John Moore and others and the refusal and granting of other applications, 238; Returns to Order of 7th July and 21st September, respectively referred to Select Committee, 463; Report brought up, 572	8	439
Motion made (<i>Mr. J. P. Abbott</i>) that the name of Mr. J. P. Abbott be removed from Select Committee, 462.		
Petition presented from John Moore and John McBean of Armidale, praying that they may be heard by counsel before the Committee, presented and read by the Clerk, 345; prayer of Petition granted, 348	8	465
Petition presented from Joseph Francis M'Kinlay, of Armidale, praying to be heard before Select Committee, and prayer granted, 468	8	467

REFERENCES TO THE VOTES AND PROCEEDINGS, VOL. I—13TH PARLIAMENT—SESSION, 1887-8.	PAPERS.	
	VOL.	PAGE.
M		
MINING—(continued):—		
APPLICATIONS OF MESSRS. HAUGHTON AND PALMER TO MINE UNDER RESERVES AT KAHIBAH:—		
Motion made (<i>Mr. J. P. Abbott</i>) for all, with all correspondence, surveys, plans, and reports, and any permits issued in respect of, and any application to convert such permit into a lease, 41;		
Return to Order laid on Table, 252	8	369
APPLICATIONS FOR MINERAL LEASES:—		
Return to Order (<i>Second Session, 1887</i>), laid on Table, 223	8	337
APPLICATION OF MR. J. F. CONNOLLY TO MINE IN PARISH OF CURRAJONG:—		
Motion made (<i>Mr. Stokes</i>) for all correspondence in reference to, between 1884 and 1887, 118;		
Return to Order laid on Table, 294	8	349
BULLI COLLIERY EXPLOSION:—		
Copy of the Attorney-General's opinion respecting, laid on Table, 35	8	435
Motion made (<i>Mr. Melville</i>) for all replies, letters, &c., by Mr. Mackenzie respecting Commission's Report, 185; Return to Order, laid on Table, 196	8	437
Motion made (<i>Mr. Melville</i>) that this House do now adjourn to consider statements made by Examiner of Coal-fields in Papers laid on Table, and reflecting upon Commissioners Report on, and negated, 200.		
CHARGES AGAINST EXAMINER OF COAL-FIELDS:—		
Report on, laid on Table, 273	8	217
CLAIM OF MATTHEW M'IVOR TO A TIN-MINE AT PHEASANT'S CREEK:—		
Report of Select Committee of Session 1887 adopted, 273.		
CLAIMS OF WILLIAM TOM, JUNIOR, AND J. H. A. LISTER AS FIRST DISCOVERERS OF GOLD IN THIS COLONY:—		
Motion made (<i>Mr. Dalton</i>) for all petitions, letters, papers, &c., in connection with, 231.		
DIAMOND DRILL, No. A:—		
Motion made (<i>Mr. Hurley</i>) for all correspondence and agreements respecting application for use of, dispatched to Clarence Siding, 232; Return to Order laid on Table, 252	8	411
DIAMOND DRILLS:—		
Return showing outstanding accounts in connection with and Water Augers, laid on Table, 273	8	433
DUCKENFIELD COLLIERY:—		
Correspondence relating to alleged Breaches of the Coal-fields Regulation Act at, laid on Table, 252.	8	343
ENDOWMENT TO MUNICIPALITIES:—		
Opinions of Attorneys-General in the years 1876 and 1888 on, laid on Table, 642	2	273
FATAL ACCIDENT TO JOHN MANSFIELD:—		
Report and Evidence in connection with, at the Northumberland Colliery, laid on Table, 475	8	249
FATAL ACCIDENT TO EDWARD M'CARRAN:—		
Report and Evidence in connection with, at the West Wallsend Colliery, laid on Table, 475	8	259
EXPLOSIVE GAS IN THE SOUTH WARATAH COLLIERY:—		
Papers in connection with the influx of, laid on Table, 475	8	253
GOLD-MINING AND MINERAL LEASES:—		
Motion made (<i>Mr. Wall</i>) for a return of, applied for during five years ending 1st September, 1887, showing the period that intervened between the date of application and the date of issue, 35;		
Return to Order laid on Table, 191	8	473
GOLD-MINING LEASES AT ARMIDALE:—		
Return respecting, laid on Table, 642	8	485
JEREMIAH SHEA:—		
Petition from, representing that he was sent to the Colony in 1818; that he is 88 years of age; that he discovered gold on the Northern Fields in 1852, but has received no acknowledgment for the same; that he is now, through infirmity, unable to earn his living, and praying relief, presented, 112	8	1217
LEASES IN THE BINGERA DISTRICT:—		
Return to Order (Session 1885-86) laid on Table, 352	8	409
LANDS HELD BY MR. GARRETT, MINISTER FOR LANDS:—		
Return respecting, laid on Table, 578	8	263
MESSRS. HUGH McNEILL AND PARTY—MINERAL LEASE AT CAPTAIN'S FLAT:—		
Motion made (<i>Mr. O'Sullivan</i>) for Select Committee, 403; Report brought up, 592	8	491
Petition presented (<i>Mr. Dibbs</i>) from Hugh McNeill and Party, praying to be heard by Counsel before the Select Committee, 491	8	537
MINERAL CONDITIONAL PURCHASE OF JAMES KENNEDY BROUGHM:—		
Motion made (<i>Mr. Chanter</i>) for Papers, 601.		
MINERAL LICENSE TAKEN UP BY MICHAEL CHARLES BENHAM, PARISH OF PICTON:—		
Motion made (<i>Mr. Chanter</i>) for papers in reference to, 635.		
MINING ACT FURTHER AMENDMENT ACT:—		
Regulations relating to, laid on Table, 492	8	539
MINERS' RIGHTS:—		
Petition presented (<i>Mr. Sydney Smith</i>) from miners of Hill End, Sofala, Sunny Corner, Rylstone, Cargo, Gulgong, Silverton, Limestone, Mount McDonald, Bathurst, Wattle Flat, Nymagee, Hargraves, Copeland, Parkes, Mount Brown, Oberon, and Tambaroora, representing that the charge for a Miners' Right is excessive, and that the Miners' Right should remain in force for twelve months, and praying the House to consider the matter and grant relief, 380	8	469
MINES DEPARTMENT:—		
Annual Report of the Stock Branch for 1886, laid on Table, 6; Do. 1887, laid on Table, 408	8	543-573
Annual Report of Forest Branch for 1886, laid on Table, 97	5	765
Annual Report for 1887, laid on Table, 378	8	1
PROSPECTING FOR GOLD AND OTHER MINERALS:—		
Motion made (<i>Mr. Sydney Smith</i>) for Committee of the Whole for Address to Governor that £50,000 be placed on Estimates for 1888 for, 89; House in Committee and Resolution (£20,000), agreed to, 108.		
SMELTING WORKS FOR TREATING BULK SAMPLES OF ORE:—		
Motion made (<i>Mr. Wall</i>) for erection of, by Mines Department, and withdrawn, 354.		
TALBA COAL-MINING RESERVE:—		
Adjournment of the House moved (<i>Mr. McElhone</i>) in reference to Mineral Conditional Purchases made by the Lane Family and Mr. Withers, 493.		
Motion made (<i>Mr. McElhone</i>) for papers in connection with selections of the Lane Family, T. Garrett, Greville, and others, 500; Returns to Order laid on Table, 547, 580; referred to Select Committee, 587; order for printing rescinded, 592.		

REFERENCES TO THE VOTES AND PROCEEDINGS, VOL. I—13TH PARLIAMENT—SESSION, 1887-8.	PAPERS.	
	VOL.	PAGE.
M		
MINING—(continued) :—		
TERALBA COAL-MINING RESERVE—(continued) :—		
Motion made (<i>Mr. McElhone</i>) for Select Committee to inquire into selections of Lane Family, Henry J. Withers, and William Thorne, 502; name of Sir Henry Parkes substituted for name of Mr. J. P. Abbott, 585; papers referred to Select Committee, 587.		
Plan of Reserves Nos. 83 and 60, showing Mineral Conditional Purchases and Mineral Leases held thereon, laid on Table (not printed), 547		
THE MINING INDUSTRY :—		
Motion made (<i>Mr. Waddell</i>) for encouragement to by the abolition of timber licenses for timber used as fuel for smelting, 608.		
MINING ACT FURTHER AMENDMENT ACT (See "MINING").		
MINING CONDITIONAL PURCHASES (See "CONVERSION INTO MINING CONDITIONAL PURCHASES VALIDATION BILL").		
MINING BILL :—		
Motion made (<i>Mr. Abigail</i>) for Committee of the Whole, 592; House in Committee, resolution agreed to, presented, and read 1 ^o , 602.		
MINING ON PRIVATE PROPERTY :—		
Petitions praying that a Bill be passed providing for, 257 (13)	8	471
MINISTER FOR LANDS (See "CROWN LANDS").		
MINISTERIAL ELECTION BILL :—		
Motion made (<i>Mr. O'Mara</i>) for leave to bring in, presented and read 1 ^o , 36; Order of the Day postponed, 107, 147, 234, 252, 285, 321, 508.		
MINISTERIAL STATEMENT :—		
Made by Sir Henry Parkes, 123, 404.		
Made by Sir Henry Parkes—Resignation of Mr. Wise, the Attorney-General, 252.		
Made by Sir Henry Parkes—Resignation of Mr. Garrett, the Minister for Lands, 613.		
Made by Sir Henry Parkes—Acceptance of office as Attorney-General of Mr. G. B. Simpson, 264.		
Made by Mr. Burns—Revenue Receipts and Expenditure during the quarter ended 31 March, 1888, 361.		
Made by Sir Henry Parkes—Chinese Immigration, 364, 451.		
Made by Sir Henry Parkes—Public Business, Public Accounts, Estimates for Military Service, 501.		
Made by Sir Henry Parkes—Railway Policy, 501, 641.		
MITCHELL, JOSEPH, ESQ., M.P. :—		
Election of, as a Member for Newtown, reported, sworn, 303.		
Motion made (<i>Mr. Copeland</i>) to refer seat to Elections and Qualifications Committee, and negatived, 548.		
MOAMA :—		
Report upon Extension of Channel and Improvements to Wharf, 302	3	1039
MOLONG (See "RAILWAYS"; also "CROWN LANDS").		
MONETARY AND FINANCIAL (See "STATISTICS").		
MONTPELIER ESTATE :—		
List of purchasers of leases of portions of, laid on Table (not printed), 8.		
MOORE JOHN (See "MINING").		
MOREE (See "RAILWAYS").		
MORTGAGES OF STOCK (See "LIENS ON WOOL BILL").		
MOSS VALE (See "RAILWAYS").		
MOTIONS :—		
Notice of, to take precedence, 328.		
Notices of General Business postponed in a bunch, 162, 208, 242, 248, 487, 628.		
General Orders to take precedence of, on Fridays, 593.		
Notice of postponed, 502.		
MOULDER, EDWARD HENRY (See "CROWN LANDS").		
MOUNT BROWNE (See "TELEGRAPHS").		
MOUNT VICTORIA (See "RAILWAYS").		
MUDGE LINE (See "RAILWAYS").		
MULTIPLE CABLE :—		
Information respecting, purchased, for Telephonic purposes, laid on Table, 267	4	1185
MULWALA (See "BRIDGES").		
MUNFORD'S CONDITIONAL PURCHASES AT MOLONG (See "CROWN LANDS").		
MUNICIPAL (See also "BY-LAWS"; also "DISTRICT GOVERNMENT BILL"; also "PARRA-MATTA MUNICIPAL QUARRIES BILL") :—		
ASSOCIATIONS :—		
Motion made (<i>Mr. Hawken</i>) that any measure to give effect to the principle of decentralization to confer power over local affairs should provide that the aggregation of districts, councils, shires, or municipalities into irresponsible associations shall be declared illegal, and by leave withdrawn, 29.		
CORPORATION OF THE CITY OF SYDNEY :—		
Statement of Receipts and Expenditure for 1885, 1886, and 1887, respectively, laid on Table, 429.	2	255
FORBES MUNICIPALITY :—		
Motion made (<i>Mr. Stokes</i>) for copies of all papers in connection with the special audit of accounts, 325; Return to Order laid on Table, 334	2	279
SPECIAL GRANTS TO MUNICIPALITIES :—		
Motion made (<i>Mr. Creer</i>) for Committee of the Whole to consider an Address to the Governor for, 404; Order of the Day, discharged, 508.		
LOCAL OPTION VOTE :—		
Return showing result of, taken in Metropolitan and Suburban Municipalities in February, 1888, laid on Table, 524	7	689
MUNICIPALITIES OF FORBES AND PARKES :—		
Return respecting Revenue derived from, laid on Table, 560	2	287
GRANTS FOR ROADS WITHIN MUNICIPAL BOUNDARIES :—		
Return respecting, laid on Table, 635	2	271
ENDOWMENTS TO MUNICIPALITIES :—		
Opinions of Attorneys General, in years 1876 and 1888, laid on Table, 642	2	273
MUNICIPAL LOANS BILL :—		
Motion made (<i>Mr. Day</i>) for leave to bring in, 572; presented and read 1 ^o , 573; Order of the Day postponed, 585; read 2 ^o , committed, reported with amendments, and an amended Title, report adopted, 599; read 3 ^o , passed, and sent to Council, 602; returned without amendment, 626; Assent reported, 630.		

REFERENCES TO THE VOTES AND PROCEEDINGS, VOL. I—13TH PARLIAMENT—SESSION, 1887-8.	VOL.	PAGE.
M		
MUNICIPAL ROADS AND STREETS BILL:—		
Motion made (<i>Mr. Frank Farnell</i>) for leave to bring in, presented and read 1 ^o , 22; read 2 ^o , committed, reported with amendments, and Report adopted, 42; read 3 ^o , passed, and sent to Council, 49; returned with amendments, 71; Order of the Day postponed, 77; amendments agreed to, and Message to Council, 192; Assent reported, 219.		
MUNICIPALITIES ACT OF 1867 AMENDMENT BILL:—		
Motion made (<i>Mr. Davis</i>) for leave to bring in, presented and read 1 ^o , 48; Order of the Day postponed, 65; Order of the Day discharged and Bill withdrawn, 145.		
MUNICIPALITIES ACT OF 1867 AMENDMENT BILL (No. 2):—		
Motion made (<i>Mr. Davis</i>) for Committee of the Whole, 168; House in Committee and resolution agreed to, 193; presented and read 1 ^o , 197; Order of the Day postponed, 325, 365; read 2 ^o , committed, 476.		
MURPHY, MARY ELIZABETH and WILLIAM EDWARD (See "CROWN LANDS PURCHASES VALIDATION BILL").		
MURRAY RIVER (See "BRIDGES").		
MURRAY, THE UPPER (See "BRIDGES").		
MURRUMBURRAH PLATFORM:—		
Motion made (<i>Mr. Gordon</i>) for return of goods and passenger traffic and revenue and expenditure at, 295; Return to Order laid on Table, 338	6	739
MUSIC HALLS (See "PLACES OF PUBLIC AMUSEMENT OR RESORT").		
MUSWELLBROOK (See "COMMONS," also "RAILWAYS").		
N		
NAMOI ELECTORATE:—		
REVENUE DERIVED FROM:—		
Motion made (<i>Mr. Dangar</i>) for a return showing total, from Crown Lands, mining leases and licenses, miners' rights, and timber licenses, 41.		
NARRABRI (See "RAILWAYS").		
NASH v. COPELAND (See "RAILWAYS").		
NATIONAL AND LOCAL WORKS:—		
Statement of expenditure on, in the Colony, from 1860 to 1886, laid on Table, 28	8	1231
NATIONAL PARK:—		
Particulars respecting William Ross late overseer at, laid on Table, 52	5	817
NATURALIZATION, LETTERS OF (See "CHINESE").		
NAUTICAL SCHOOL SHIP "VERNON":—		
Report for 1887, laid on Table, 285	4	683
NAVAL FORCE (See "AUSTRALASIAN NAVAL FORCE BILL," also "OFFICERS, IMPERIAL").		
NEILD, MR. J. C., M.P.:—		
Motion made (<i>Mr. Hassall</i>) for a return showing the amount paid by the Treasurer to, since his appointment as Executive Commissioner for the South Australian Exhibition, 30; Return to Order, laid on Table, 75	8	1013
NEUTRAL BAY (See "RECLAMATION OF NEUTRAL BAY AND CAREENING COVE").		
NEWCASTLE (See "CHURCH AND PERKINS STREETS NEWCASTLE BILL"; also "HUNTER STREET NEWCASTLE EXTENSION BILL"; also "PARLIAMENTARY STANDING COMMITTEE ON PUBLIC WORKS").		
NEWCASTLE SAND-DRIFT RECLAMATION ACT REPEAL BILL:—		
Motion made (<i>Mr. Abigail</i>) for leave to bring in, 112; presented and read 1 ^o , 112; Order of the Day postponed, 296, 309.		
NEW HEBRIDES:—		
Correspondence respecting evacuation of the French military posts in, laid on Table, 529	8	1,239
NEWSPAPER POSTAGE:—		
Motion made (<i>Mr. McElhone</i>) for imposition of, amendment proposed, and negatived, 303; Original Question negatived, 304.		
NEWTOWN (See "ELECTORAL").		
NEW TRIALS LIMITATION BILL:—		
Motion made (<i>Mr. Hassall</i>) for leave to bring in, presented, and read 1 ^o , 122; Order of the Day, postponed, 215, 235, 508; discharged and Bill withdrawn, 608.		
NOBBS, JOHN, ESQ., M.P.:—		
Election of, as a Member for Central Cumberland, reported, 339; sworn, 342.		
NO QUORUM:—		
In House before commencement of business, 297.		
In House after commencement of business, 108, 321, 599.		
Reported from Committee of Ways and Means, 234.		
Attendances of Members in Divisions and Counts-out	1	653
NORTH HEAD:—		
QUARANTINE STATION:—		
Motion made (<i>Mr. Lyne</i>) for all papers, letters, &c., in reference to removal of, 241; Return to Order laid on Table, 263	2	241
Motion made (<i>Mr. See</i>) for correspondence, &c., in reference to removal of, 573.		
NORTH SHORE (See "WHALING ROAD;" also, "PARLIAMENTARY STANDING COMMITTEE ON PUBLIC WORKS").		
NORTH SHORE BOROUGH'S WHARVES BILL:—		
Petition presented (<i>Mr. Trickett</i>) for leave to proceed with, under 65th Standing Order, presented, read 1 ^o , and referred to Select Committee, 23; motion made that Minutes of Proceedings and Evidence of previous Session be laid on Table and referred to Select Committee, documents laid on Table and referred, 115; Report brought up, 463	2	971
PETITIONS PRESENTED FROM:—		
Property-owners and residents of St. Leonards, in favour of, 16	2	1,005
The Captain and Secretary of the North Shore Rowing Club, to be heard by counsel or in person before the House or Select Committee in opposition, and referred to Select Committee on Bill, 40	2	1,009
P. O. Williams, A.G. Milson and others, with similar prayer, and referred to Select Committee on Bill, 40	2	1,007

REFERENCES TO THE VOTES AND PROCEEDINGS, VOL. I—13TH PARLIAMENT—SESSION, 1887-8.	PAPERS.	
	VOL.	PAGE.
N		
NORTH SHORE, MANLY, AND PITTSWATER TRAMWAY AND RAILWAY BILL:—		
Petition presented (<i>Mr. Reid</i>) for leave to bring in, 48; leave given, presented and read 1 ^o , 60; referred to Select Committee, 64; Report brought up, 89; read 2 ^o , and committed, 146; further considered in Committee, reported with amendments and report adopted, 233; read 3 ^o , passed and sent to Council, 236; returned with amendments, 635; Order of the Day postponed, 641.	2	1,011
PETITIONS IN FAVOUR OF, PRESENTED:—		
From Residents at St. Leonards and North Shore, and that provision be made to make the proposed bridge at the Spit, free of Toll, 145	2	1,027
From Residents at Manly with similar prayer, 145	2	1,027
NORTHUMBERLAND COLLIERY (See "MINING").		
NO TELLERS:—		
In Division, 59, 140.		
NOTICES OF MOTIONS:—		
Of General Business postponed in a bunch, 162, 208, 242, 248, 487, 628		
Postponed, 502.		
For motion to take precedence, 328.		
NOTIFICATIONS (See "LANDS FOR PUBLIC PURPOSES ACQUISITION ACT").		
NOWLAND, MR. (See "RAILWAYS")		
NOXIOUS TRADES:—		
Motion made (<i>Mr. Carruthers</i>) that legislation dealing with, in and around Sydney, is urgently required, and withdrawn, 232.		
NOXIOUS WEEDS IN THE DISTRICT OF THE RICHMOND RIVER:—		
Motion made (<i>Mr. Ewing</i>) for report and papers in connection with, 546; Return to Order laid on Table, 578	8	933
NUISANCE ON NORTH SHORES OF BOTANY BAY (See "BOTANY BAY").		
NUISANCES PREVENTION ACT (See "BY-LAWS").		
O		
OAKLEY PARK COAL-MINING COMPANY'S RAILWAY BILL:—		
Petition presented (<i>Mr. Hurley</i>) for leave to bring in, 252; leave given 258; presented and read 1 ^o , 263; referred to Select Committee, 268; Report brought up, 353; motion made for second reading, and amendment moved to refer back to Select Committee, and passed, 487; Report (Second) brought up, 519; Order of the Day postponed, 628	2	1,029
Petition presented from Brisbane Doyle, of Parramatta, stating that the Bill would seriously affect his rights, and praying the House to refer the Bill back to the Select Committee, 389; referred to Select Committee, 487.....	2	1,037
Petition presented from Sarah Doyle, praying that the Bill may be again referred back to the Select Committee, and that she may be heard before the Committee, 608	2	1,045
OATHS (See "CLERK OF ASSEMBLY").	2	1,047
OFFICERS, IMPERIAL:—		
Despatch relative to the employment of officers of Navy under Colonial Governments, laid on Table, 475.	2	23
Correspondence respecting engagement of military, laid on Table, 479.	2	7
OLIVER, MR., LATE INSPECTOR OF FISHERIES (See "FISHERIES").		
O'MARA, MR.:—		
A MEMBER FOR MONARO:—		
Declared guilty of persistent disorder, and removed, by Sergeant-at-Arms, from the Chamber, 220.		
OPENING OF THE SESSION:—		
Proclamation read by Clerk, 1.		
Governor's Opening Speech, 2.		
OPHTHALMIC PATIENTS (See "ASYLUMS").		
ORANGE TO MOLONG (See "RAILWAYS").		
ORDER (See "POINTS OF ORDER").		
ORDERLY CLERKS:—		
Return showing number of, employed in Brigade Office, during last twelve months, laid on Table, 334	2	29
ORDERS FOR PAPERS:—		
Motion made (<i>Mr. O'Sullivan</i>) for a return showing what Resolutions for the production of departmental papers, returns, correspondence, &c., have not been attended to, 118; Returns (<i>in part</i>) to Order, laid on Table, 191, 223, 257.....	1	839, 841, 843
Motion made (<i>Mr. Wall</i>) for a return showing number made since 1 January, 1886, which have not been complied with, 210; Returns (<i>in part</i>) to Order, laid on Table, 257, 334.....	1	845, 847
ORDERS OF THE DAY:—		
Discharged, 77, 107, 137, 145, 146, 185, 192, 233, 241, 246, 252 (2), 309, 325, 506 (2), 507, 508 (2), 608 (2).		
Of General Business postponed in a bunch, 248, 430, 487.		
Of Government Business postponed in a bunch, 417, 430, 463, 468, 487, 502, 509, 628.		
Postponed after debate, 487.		
Motion Rescinding postponement of, to day other than a sitting day, 585.		
General Business to take precedence of Motions on Fridays, 593.		
ORDNANCE LANDS TRANSFER BILL:—		
Presented and read 1 ^o , <i>pro forma</i> , 2.		
ORIGINAL GRANTS OF LAND BOUNDARIES BILL:—		
Motion made (<i>Mr. J. S. Farnell</i>) for leave to bring in, presented and read 1 ^o , 40; Order of the Day postponed, 77, 107, 145, 169, 192, 224; read 2 ^o , and committed, 253; Order of the Day postponed, 285, 321, 341, 386, 433, 493.		
O'ROURKE AND McSHARRY (See "RAILWAYS").		
O'SULLIVAN, MR.:—		
MEMBER FOR QUEANBEYAN:—		
Declared guilty of persistent disorder, and removed, by Sergeant-at-Arms, from the Chamber, 221.		
OVERTIME TO OFFICERS (See "CROWN LANDS").		
OYSTERS (See "ROYALTY ON OYSTERS ABOLITION BILL").		

REFERENCES TO THE VOTES AND PROCEEDINGS, VOL. I—13TH PARLIAMENT—SESSION, 1887-8.	PAPERS.	
	VOL.	PAGE.
P		
PADDINGTON (See "ELECTORAL").		
PARAGUAY, REPUBLIC OF (See "DESPATCHES").		
PARISH ROADS (See "ROADS").		
PARKES (See "RAILWAYS"; also "MUNICIPAL"; also "PUBLIC BUILDINGS"; also "CROWN LANDS").		
PARKES, THE HONORABLE SIR HENRY, G.C.M.G., M.P.:—		
Motion made (<i>Mr. McElhone</i>) that House do now adjourn, to call attention to replies given in reference to paragraphs in certain newspapers, commenting on a compromise alleged to have been made by, with his creditors, some of whom, it is alleged, are his colleagues in the present Government,—and negatived, 70.		
Resignation of, as a Member for St. Leonards, reported, and seat declared vacant, 73; issue and return of writ reported, sworn, 87.		
List of purchasers of leases of portions of the Montpelier Estate, laid on Table (not printed), 85.		
Ministerial Statement made by, 123, 252, 264, 364, 404, 451, 501 (2), 613, 641.		
PRIVILEGE:—		
Motion made (<i>Mr. Garvan</i>) that Sir Henry Parkes, Colonial Secretary and Premier, having tendered his resignation as a Member, and said resignation having been accepted, this House declines to transact any further business till the Premier occupies his Seat as an elected Member of this House, and negatived, 76.		
Name substituted for Mr. J. P. Abbott on Select Committee, "Teralba Coal-mining Reserve," 585		
PARKES, VARNEY, Esq., M.P.:—		
Resignation of, as Member for Central Cumberland, reported, and seat declared vacant, 311.		
PARKS:—		
PUBLIC:—		
Notification under the Lands for Public Purposes Acquisition Act of the resumption of land for, Albury, laid on Table, 6	5	827
Returns showing subsidies, granted for improvement of, for the year 1887, laid on Table, 35	5	805
Return showing subsidies from the year 1880 to 1887 inclusive, laid on Table, 524	5	807
NATIONAL:—		
Particulars respecting William Ross, late overseer at, laid on Table, 52	5	817
CENTENNIAL:—		
Motion made (<i>Mr. O'Sullivan</i>) for all papers, &c., in connection with scheme of, 208.		
Motion made (<i>Mr. Dibbs</i>) for papers relating to construction and dedication, 308.		
RESERVE AT KURNELL, BOTANY BAY:—		
Motion made (<i>Mr. Carruthers</i>) that immediate steps be taken to secure, adjacent to the place where Captain Cook first landed in Australia, and withdrawn, 232.		
PARLIAMENT (See also "HANSARD"; also "PRIVILEGE"):—		
Opening of the Session, 1.		
Prorogued, 642.		
FRANKING MEMBERS CORRESPONDENCE ON PUBLIC BUSINESS:—		
Motion made (<i>Mr. Ewing</i>) that all letters on public business incidental upon the representation in Parliament of an Electorate shall be carried free by post, 24; and negatived, 25.		
THE LEGISLATIVE COUNCIL:—		
Motion made (<i>Mr. Walker</i>) that one Chamber is all that is necessary for the transaction of the Parliamentary Business—that the Legislative Council is useless and dangerous, and ought to be abolished, and withdrawn, 36.		
PAYMENT OF MEMBERS OF THE LEGISLATIVE ASSEMBLY:—		
Motion made (<i>Mr. Fletcher</i>) for Committee of the Whole, to consider the necessary steps to be taken to make provision for, 28; House in Committee, and resolution agreed to, 42.		
SALE OF INTOXICATING DRINK IN THE BUILDINGS:—		
Motion made (<i>Mr. Thompson</i>) that the practice of selling and supplying intoxicating drink within the walls of the building should be at once discontinued, and negatived, 59.		
HOUSES OF—STATE HOUSE:—		
Motion made (<i>Mr. Dibbs</i>) for Committee of the Whole to consider expediency of bringing in a Bill to appropriate £150,000 from sale of portion of Centennial Park for erecting a State House, to be used as Houses of Parliament, in Macquarie-street, 60; Order of the Day, postponed, 103, 192(2), 252, 508; discharged, 586.		
NEW HOUSES OF:—		
Motion made (<i>Mr. R. Burdett Smith</i>) that no further delay take place in the erection of, and by leave withdrawn, 169.		
LIGHTING BUILDINGS WITH ELECTRIC LIGHT:—		
Motion made (<i>Mr. Thompson</i>) for all recommendations, tenders, correspondence, &c., in connection with, 103;		
PORTRAIT OF WILLIAM CHARLES WENTWORTH:—		
Letter reported from Executive Commissioner of the Centennial Exhibition, Melbourne, asking for loan of pictures, and resolution passed against sending them, 569.		
PARLIAMENTARY REPRESENTATIVES ALLOWANCE BILL:—		
Motion made (<i>Mr. Garrett</i>) for Committee of the Whole, 208; House in Committee, 258; Resolution reported and agreed to, 259; Message from the Governor, 268; read 1 ^o , 268; read 2 ^o , committed, reported, and report adopted, 520; read 3 ^o passed 548; sent to Council, 549.	1	885
PARLIAMENTARY STANDING COMMITTEE ON PUBLIC WORKS:—		
Motion made (<i>Mr. Sutherland</i>) for appointment of, as provided for by the Public Works Act of 1883, Committee appointed by Ballot, 508.		
PUBLIC WORKS REFERRED TO:—		
Wharfage accommodation, Woolloomooloo Bay, 640.		
Improvements to the Circular Quay, 640.		
Storage Reservoir at Potts Hill, 640.		
Dredge and plant for Sydney Harbour, 640.		
Second pipe between Potts Hill and Crown-street, 640.		
Improvements to the entrance of the Richmond River, 640.		
Bridge at the Spit, Middle Harbour, 640.		
New Central Police Court, 640.		
Improvements to the entrance of the Clarence River, 641.		
Drainage works, Manly, 641.		
Drainage works, North Shore, 641.		
Drainage works for the Western Suburbs, 641.		
Harbour improvements at Newcastle, 641.		

REFERENCES TO THE VOTES AND PROCEEDINGS, VOL. I—13TH PARLIAMENT—SESSION, 1887-8.		PAPERS.	
		VOL.	PAGE.
P			
PARNELL, MESSRS. AND MISSES (See "CROWN LANDS").			
PARRAMATTA (See also "BRIDGES") :—			
INDUSTRIAL SCHOOL FOR GIRLS :—			
Amended Regulations under the Industrial Schools Act of 1866, laid on Table, 155		4	521
GAOL :—			
Notification of resumption, under Lands for Public Purposes Acquisition Act, of land in parish of Field of Mars, required for extension of, laid on Table, 231		4	1227
POLICE MAGISTRATE FOR :—			
Return to Order (Session 1885), laid on Table, 425		2	627
Motion made (<i>Mr. Frank Farnell</i>) for Address for papers in connection with appointment of, 429; Returns to Addresses laid on Table, 451 (not printed), 635		2	629
PARRAMATTA CHURCH-STREET AMENDED ALIGNMENT BILL :—			
Petition presented (<i>Mr. Hugh Taylor</i>) for leave to bring in, 302; leave given, presented, and read 1 ^o , 308; referred to Select Committee, 314; Report brought up, 348; Order of the Day postponed, 416, 508, 513, 543, 579, 585; read 2 ^o , committed, reported without amendment, report adopted, 599; read 3 ^o , passed, and sent to Council, 602; returned without amendment, 626; Assent reported, 629.		2	1049
PARRAMATTA MUNICIPAL QUARRIES BILL :—			
Petition presented (<i>Mr. Hugh Taylor</i>) for leave to bring in, 302; leave given, presented, and read 1 ^o , 308; referred to Select Committee, 314; Report brought up, 348; Order of the Day postponed, 416, 508, 513, 543, 579, 585; read 2 ^o , committed, reported without amendment, report adopted, 599; read 3 ^o , passed, and sent to Council, 601.		2	1055
PARROTT, MAJOR (See "MILITARY").			
PARRY'S CONDITIONAL PURCHASES (See CROWN LANDS").			
PARTNERSHIP BILL :—			
Motion made (<i>Mr. J. P. Abbott</i>) for Committee of the Whole, 64; Order of the Day postponed, 103, 147, 389; Order of the Day discharged, 507.			
PASSENGER TRAFFIC (See "RAILWAYS").			
PASTORAL LEASES :—			
Return giving particulars of appeals in connection with rents of, not yet dealt with by Minister, laid on Table, 403		5	191
PASTURES AND STOCK PROTECTION ACT AMENDMENT BILL :—			
Motion made (<i>Mr. Garrett</i>) for Committee of the Whole, 240; Order of the Day for Committee discharged, 309.			
PASTURES AND STOCK PROTECTION BOARDS :—			
Motion made (<i>Mr. J. P. Abbott</i>) for copies of balance-sheets, 349; Return (<i>in part</i>) to Order laid on Table, 619; Further Return to Order laid on Table, 635		8	599, 635
PATENT FEES (See "ATTORNEY-GENERAL").			
PATENTS (See "INVENTIONS") :—			
OFFICE :—			
Regulations under Patents Act laid on Table, 257, 378		8	1241, 1245
PATENTS LAW AMENDMENT ACT AMENDMENT BILL :—			
Motion made (<i>Mr. Haynes</i>) for leave to bring in, 585.			
PATERSON RIVER :—			
CONTRACT FOR BRIDGE OVER :—			
Motion made (<i>Mr. Hurley</i>) for Select Committee, 404.			
PATHOLOGIST (See "PRINCE ALFRED HOSPITAL").			
PATIENTS RECEIVED INTO HOSPITALS (See "HOSPITALS").			
PAYMENT OF MEMBERS OF THE LEGISLATIVE ASSEMBLY (See also "PARLIAMENTARY REPRESENTATIVES ALLOWANCE BILL").			
Motion made (<i>Mr. Fletcher</i>) for Committee of the Whole, to consider the necessary steps to be taken to make provision for, 28; House in Committee, and resolution agreed to, 42;			
PEARCE'S CORNER (See "RAILWAYS").			
PEAT'S FERRY ACCIDENT (See "RAILWAYS").			
PENAL ADMINISTRATION :—			
Report respecting the proposed changes in, laid on Table, 52		4	1213
PENRITH (See "RAILWAYS" also "BRIDGES").			
PERMANENT ARTILLERY (See "MILITARY").			
PERMANENT TRUSTEE COMPANY OF NEW SOUTH WALES BILL :—			
Received from Legislative Council, and on motion (<i>Sir Henry Parkes</i>), read 1 ^o 469; read 2 ^o committed, reported without amendment, report adopted 508; read 3 ^o , passed, and returned to Council, 524; Assent reported, 539.			
PERPETUAL TRUSTEE COMPANY BILL :—			
Petition presented (<i>Mr. Trickett</i>) for leave to proceed with, under the 65th Standing Order, 35; received from Legislative Council, read 1 ^o and 2 ^o , 98; Order of the Day postponed, 107, 147, 234, 252, 288; committed, reported with amendments, and report adopted, 342; Order of the Day postponed, 353, 479; read 3 ^o passed and returned to Council with amendments, 505; amendments agreed to 538; Assent reported, 555.			
PERRY'S COMBINATION TRUCK (See "RAILWAYS").			
PEST (See "RABBIT PEST").			
PETERSHAM (See "RAILWAYS").			
PETITIONS (See also "INSOLVENCY") :—			
Sessional Order as to printing of, passed, 12.			
Read by Clerk, 76, 84, 88, 127, 145, 218, 246, 252, 294, 303, 345, 352, 421, 437, 454, 492, 496, 505, 519, 543, 565, 579, 635.			
Referred to Select Committee, 40(2), 122, 135, 165, 192, 215, 232, 324, 328, 403, 491.			
To be heard in person or by Counsel before Select Committee, 144, 150, 161, 181, 192, 208, 341, 294.			
Weekly Abstract of, Nos. 1 to 37		1	745
PHARMACEUTICAL SOCIETY OF NEW SOUTH WALES INCORPORATION BILL :—			
Petition presented (<i>Mr. Sydney Smith</i>) for leave to bring in, 16; leave given, 23; presented and read 1 ^o , 25; referred to Select Committee, 28; Report brought up, 76; motion made for 2 ^o , and debate adjourned, 145; motion for 2 ^o negatived, 233.		2	1061
PHEASANT'S CREEK TIN-MINE See ("MINING").			
PITT, MR. GEORGE MATCHAM, JUNIOR (See "CROWN LANDS").			
PITTWATER TRAMWAY AND RAILWAY (See "NORTH SHORE, MANLY, AND PITTWATER TRAMWAY AND RAILWAY BILL").			

REFERENCES TO THE VOTES AND PROCEEDINGS, VOL. I—13TH PARLIAMENT—SESSION, 1887-8.	PAPERS.	
P	VOL.	PAGE.
PLACES OF PUBLIC AMUSEMENT OR RESORT :—		
Report on Theatres and, laid on Table, 128	8	1209
Motion made (<i>Mr. Dowel</i>) that the Government should bring in a Bill to place under proper control; to provide improved construction, so as to insure greater immunity from risk from fire or panic, 129.		
POINTS OF ORDER (See also "SPEAKER") :—		
Arising in the House, 24, 42, 156, 192, 224, 252, 259, 315, 426, 433, 455, 574, 579, 587, 599, 635.		
Reported from Committee of Supply, 433 ⁽²⁾ , 452.		
POLICE (See also "ELECTORAL") :—		
Correspondence respecting duties of, laid on Table, 82	4	1211
Report of Department for 1887, laid on Table, 257	4	1203
WILLIAM STAFFORD, EX-SERGEANT :—		
Motion made (<i>Mr. O'Sullivan</i>) for Papers respecting dismissal of, 338; Return to Order, laid on Table, 352	4	1215
Petition presented (<i>Dr. Ross</i>), from William Stafford, in reference to dismissal of, 425	4	1221
POLICE MAGISTRATE (See "ADMINISTRATION OF JUSTICE").		
POLICY OF THE GOVERNMENT (See "VOTE OF CENSURE").		
POLL-TAX (See "CHINESE").		
POOLE, MR. AND MRS. (See "CROWN LANDS").		
POOR OF SYDNEY, RELIEF TO (See "CENTENARY OF THE COLONY"; also "SICK POOR OF THE METROPOLIS").		
POPULATION (See also "STATISTICS") :—		
Return showing estimated on 31 December, 1887, of New South Wales and Victoria respectively, laid on Table, 352	7	1393
POSTAL :—		
Thirty-second Annual Report of the Postmaster-General, being for 1886, laid on Table, 6	4	783
Thirty-third Annual Report of the Postmaster-General, being for 1887, laid on Table, 635	4	881
FRANKING MEMBERS' CORRESPONDENCE ON PUBLIC BUSINESS :—		
Motion made (<i>Mr. Ewing</i>) that all letters on public business incidental upon the representation in Parliament of an Electorate shall be carried free by post, 24, and negatived, 25.		
LETTER-SORTERS AND LETTER-CARRIERS :—		
Motion made (<i>Mr. Frank Smith</i>) for a return showing the number of sorters appointed in General Post Office during two years, with names, dates of appointment, and salaries, also number of carriers who have received promotion during same period, 77; Return to Order laid on Table, 128	4	981
FUTURE MAIL SERVICE BETWEEN GREAT BRITAIN AND AUSTRALIA, VIA SUEZ :—		
Further Correspondence respecting, laid on Table, 252, 341	4	1037-1081
Motion made (<i>Mr. Roberts</i>) for Committee of the Whole to consider resolutions, 356; Message from Governor recommending, 355; Order of the Day postponed, 361; House in Committee, Resolutions reported, 365; agreed to, 366.	4	1109
CONFERENCE :—		
Proceedings of, held in Sydney in January, 1888, laid on Table, 252	4	883
POSTAGE ON NEWSPAPERS :—		
Motion made (<i>Mr. McElhone</i>) for imposition of, amendment moved and negatived, 303; Original Question negatived, 304.		
CORRESPONDENCE, RECORD, AND MAIL BRANCHES, GENERAL POST OFFICE :—		
Return showing names and length of service of Clerks employed in, laid on Table, 324	4	979
TRANSIT CHARGES ON MAILED THROUGH FRANCE AND ITALY :—		
Correspondence respecting, laid on Table, 341	4	1111
FORMATION OF STREET NORTH OF THE GENERAL POST OFFICE :—		
Motion made (<i>Mr. Dibbs</i>) for plan showing the proposed new street, with <i>Mr. Dibbs'</i> proposed amendment, 454; Return to Order laid on Table (<i>as an Exhibit only</i>), 602	4	1125
Correspondence and papers laid on Table, 484	4	1141
Message from Governor, 383; Motion made (<i>Mr. Roberts</i>) for Committee of the Whole to consider Resolutions, 390; Order of the Day postponed, 410; House in Committee, 416, 479, 484, 487.		
CORRESPONDENCE RE-DIRECTED FOR MEMBERS :—		
Motion made (<i>Mr. Chanter</i>) for no further charge to be made on, and the motion not having been put at 7 o'clock, Government Business took precedence, 433.		
POSTPONEMENTS RESCINDED :—		
Motion made (<i>Mr. J. P. Abbott</i>) in reference to business fixed for other than a sitting day, 585.		
POTTS' HILL (See "WATER SUPPLY") (See also "PARLIAMENTARY STANDING COMMITTEE ON PUBLIC WORKS").		
PRACTICE OF MEDICINE AND SURGERY (See "MEDICINE AND SURGERY").		
PRECEDENCE OF BUSINESS (See "BUSINESS OF THE HOUSE").		
PREFERENTIAL CLAIMS FOR RENT BILL :—		
Motion made (<i>Mr. Wall</i>) for leave to bring in, 76.		
PRE-LEASE (See "CROWN LANDS").		
PREMISES RENTED BY THE GOVERNMENT :—		
Further Return to Order (<i>Second Session, 1887</i>), laid on Table, 191	8	1249
PRESBYTERIAN CEMETERY AT MACLEAN :—		
Motion made (<i>Mr. McFarlane</i>) for a Select Committee to inquire into claims of Messrs. J. Macdonald, F. Mackenzie, and D. Shearer, to be reinstated as Trustees, 71; Petition presented on 11th May, 1887, referred, 122.		
Petition from Moderator of the General Assembly, for leave to be represented before the Select Committee, presented, 123	8	1255
PRESERVATION OF FISH (See "INLAND WATERS FISHERIES BILL").		
PREVIOUS QUESTION :—		
Moved and negatived, 165.		
PRINCE ALFRED HOSPITAL :—		
Motion made (<i>Mr. Hassall</i>) for all correspondence between the University and W. C. Wilkinson, Esq., M.P., relative to appointment of Pathologist or Physician to, 231; Return to Order laid on Table, 257	4	775
PRINTING OFFICE (See "GOVERNMENT").		
PRISONS (See "ADMINISTRATION OF JUSTICE").		
PRIVATE BARS IN PUBLIC HOUSES :—		
Motion made (<i>Mr. Henson</i>) that the system of, is an evil the Government should at once take steps to suppress; Previous Question moved and negatived, 165.		
PRIVATE BILLS :—		
Vote of Chairman of Select Committee on, Sessional Order passed, 11.		
Motion made (<i>Mr. Barbour</i>) for Committee of the Whole to consider the question of remuneration to Members attending on Select Committees, 608.		

REFERENCES TO THE VOTES AND PROCEEDINGS, VOL. I—13TH PARLIAMENT—SESSION, 1887-8.	PAPERS.	
	VOL.	PAGE.
P		
PRIVILEGE :—		
Motion made (<i>Mr. Garvan</i>) that Sir Henry Parkes, Colonial Secretary and Premier, having tendered his resignation as a Member, and said resignation having been accepted, this House declines to transact any further business till the Premier occupies his Seat as an elected Member of this House, and negatived, 76.		
Letter from Mr. Thomas Robertson, apologising for having interrupted the proceedings of the House by interjection, and apology accepted, 79.		
REMOVAL OF RECORDS FROM CUSTODY OF THE CLERK :—		
Motion made (<i>Mr. Foster</i>) that the Honorable Member for the Hume, Mr. Lyne, has been guilty of contempt in keeping papers laid on Table of the House in his own custody and out of custody of the Clerk, and that he be required to leave them in such custody, as required by Standing Order, documents returned, and motion by leave withdrawn, 53.		
SEAT OF THE HONORABLE BERNHARD RINGROSE WISE, ESQUIRE :—		
Motion made (<i>Mr. Dibbs</i>) to refer to Committee of Elections and Qualifications whether Mr. Wise, one of the Members for South Sydney, has not, since his election, accepted an office of emolument in having accepted a fee of fifty-five guineas from the Commissioner for Railways, in contravention of the 28th section of the Constitution Act, 53; Report brought up, 55	1	903
SEAT OF JOHN HAYNES, ESQUIRE :—		
Motion made (<i>Mr. Melville</i>) that it be referred to the Committee of Elections and Qualifications to report whether, by reason of his becoming a bankrupt or an insolvent debtor, has not and is not now vacant, and negatived, 145.		
SEAT OF JOSEPH MITCHELL, ESQUIRE :—		
Motion made (<i>Mr. Copeland</i>) to refer to Elections and Qualifications Committee the question as to corrupt practices at the last Election, and negatived, 548.		
SLATTERY v. YOUNG :—		
Speaker acquaints House of receipt of letter from Mr. Hourigan, Solicitor, asking him to name a Solicitor to accept on his behalf, service of a Writ issued at the instance of Mr. T. M. Slattery against him for his action in causing Mr. Slattery to be removed from the Chamber; letter read by Clerk, motion made (<i>Sir Henry Parkes</i>) that Mr. Speaker have leave to appear and plead, that Crown Solicitor be instructed to accept service of Writ, and that Attorney-General defend the action, 228.		
NOTICE OF MOTION TO RESCIND APPOINTMENT OF MR. SPEAKER :—		
Mr. Speaker ruled that motion submitted by Sir Henry Parkes, "That notice be not entered on the Votes and Proceedings, could not be moved as, 252.		
GARRETT v. DIBBS :—		
Motion made (<i>Mr. Dibbs</i>) That the Crown Solicitor be instructed to defend the action of, in the interest of the Privileges of this House, and negatived, 326.		
SPEECH MADE BY MR. HAYNES :—		
Mr. Melville brought under notice a statement in a speech reported in the <i>Australian Star</i> , and moved that it be read by Clerk, 364; statement read by the Clerk, and Motion made (<i>Mr. Melville</i>) censuring Mr. Haynes, and negatived, 365.		
DISCHARGE OF MEMBER FROM CUSTODY OF SERGEANT-AT-ARMS :—		
Motions made in reference to Mr. McElhone. Hon. Member admitted to the Bar to make explanation and apologise, and discharge authorized. Speaker directed Sergeant-at-Arms accordingly, 485, 486.		
PRODUCTION (See "STATISTICS").		
PRODUCTION OF WINES (See "WINES").		
PRO FORMA BILL :—		
Ordinance Lands Transfer Bill, presented and read 1 ^o , 2.		
PROGRESS OF THE COLONY (See "STATISTICS").		
PROPERTY TAX BILL :—		
Message from Governor, 234; Resolution reported from Ways and Means and agreed to; Ordered (<i>Mr. Burns</i>), founded on Resolution of Ways and Means presented and read 1 ^o , 561; Point of Order as to whether Bill was properly before the House, ruled against by Mr. Speaker, read 2 ^o , committed, 574; further considered in Committee, 595.	3	839
Petition presented from Banking Companies in opposition to, 586	3	841
PROPOSED NEW STANDING ORDERS (See "STANDING ORDERS").		
PROROGATION SPEECH :—		
Delivered by Governor, 643.		
PROSECUTIONS UNDER THE COMPULSORY CLAUSE OF THE PUBLIC INSTRUCTION ACT :—		
Information respecting, laid on Table, 437	4	501
PROSPECT DAM :—		
Reports of Messrs. Bishop, Whitton, and Bennett, C.Es., on, laid on Table, 529	5	849
PROSPECTING FOR GOLD AND OTHER MINERALS (See "MINING").		
PRUEN, REGINA v. (See "ADMINISTRATION OF JUSTICE").		
PUBLIC AMUSEMENT HALLS (See "PLACES OF PUBLIC AMUSEMENT OR RESORT").		
PUBLIC BUILDINGS :—		
TOWNS OF FORBES AND PARKES :—		
Return showing expenditure on, laid on Table, 578	8	1305
PUBLIC CHARITIES (See "CHARITIES").		
PUBLIC HOUSES (See "LICENSING ACT").		
PUBLIC INSTRUCTION ACT (See "EDUCATION").		
PUBLIC LANDS BILL (See "CROWN LANDS BILL").		
PUBLIC PARKS (See "PARKS").		
PUBLIC PARKS ACT :—		
Proclamation under, extinguishing as a public highway part of the St. Leonards Recreation Reserve, laid on Table, 6	5	811
PUBLIC PURPOSES (See "CROWN LANDS").		
PUBLIC SCHOOL (See "EDUCATION").		
PUBLIC TANKS AND WELLS :—		
CONSTRUCTION AND MAINTENANCE OF :—		
Motion made (<i>Mr. Waddell</i>) that so much of the Return (<i>in part</i>) to Order (<i>Session 1883-4</i>) laid on Table on 19 November, 1884, as relatives to Galathera and Boggy Creek, be printed, 174	8	49
Motion made (<i>Mr. Waddell</i>) for all papers, minutes, and reports in reference to complaints of officers of the Mines Department against Mr. Bennett, Commissioner and Engineer for Roads, respecting, and all correspondence respecting loss and inconvenience through works of, being divided between the Works and Mines Departments, 174; Return to Order, laid on Table, 252	8	671
DAYS DALE :—		
Notification of Resumption of land for, laid on Table, 145	8	951

REFERENCES TO THE VOTES AND PROCEEDINGS, VOL. I—13TH PARLIAMENT—SESSION, 1887-8.	PAPERS.	
	VOL.	PAGE.
P		
PUBLIC VEHICLES REGULATION ACT AMENDMENT BILL:—		
Motion made (<i>Dr. Wilkinson</i>) for leave to bring in, 361.		
PUBLIC WHARF (See "WHARVES").		
PUBLIC WORKS (See also "HOSPITALS"; also "PARLIAMENTARY STANDING COMMITTEE ON PUBLIC WORKS").		
PARLIAMENTARY STANDING COMMITTEE:—		
Motion made (<i>Mr. Sutherland</i>) for appointment of, as provided under Public Works Act of 1888, appointed by Ballot, 508.		
PUBLIC WORKS BILL:—		
Motion made (<i>Sir Henry Parkes</i>) for Committee of the Whole, 52; House in Committee, and Resolution agreed to, 115; Message from Governor, 135; presented and read 1 ^o , 150; Order of the Day, postponed, 229; motion made for 2 ^o , and debate adjourned, 259; resumed, read 2 ^o , and committed, 264; further considered in Committee, 277; further considered in Committee, reported and Report adopted, 281; Order of the Day, postponed, 309, 314, 335, 338, 365; recommitted, reported with further amendments, report adopted, 373; read 3 ^o , passed, sent to Council, 380; returned with amendments, 442; amendments agreed to (including an amendment in the Title) and message to Council, 463; assent reported, 492.	8	1259
PUBLIC WORKS LOAN BILL:—		
Ordered (<i>Mr. Burns</i>), founded on Resolution of Ways and Means, No. 13; presented and read 1 ^o , 628; read 2 ^o , committed, reported with an amendment and report adopted, read 3 ^o , passed, and sent to Council, 640; returned without amendment, 642; assented to in Legislative Council Chamber, 642.		
PUBLIC WORKS DEPARTMENT (See also "CIVIL SERVICE"):—		
TENDERS CALLED FOR, BY:—		
Return to Order (<i>Second Session, 1887</i>), laid on Table, 6	6	707
PURCHASE BY THE GOVERNMENT:—		
OF LAND ADJOINING THE AUSTRALASIAN STEAM NAVIGATION COMPANY'S WHARF:—		
Motion made (<i>Mr. Melville</i>) for a Select Committee to inquire into, Committee appointed by Ballot, 30. Report brought up, 305	3	917
Motion made (<i>Mr. Dibbs</i>) for an Address to the Governor, that the evidence taken discloses injudicious and unsatisfactory administration by the Government, and that the amount paid was in excess of its value, 329.		
Correspondence respecting, laid on Table, and referred to Select Committee, 51	3	1011
AUSTRALASIAN STEAM NAVIGATION COMPANY'S PROPERTY:—		
Motion made (<i>Mr. Trickett</i>) for all claims, correspondence, valuations, &c., connected with, 136;		
Return to Order, laid on Table, 191	3	1013
PRECEDENCE OF NOTICE OF MOTION:—		
Motion made (<i>Mr. Dibbs</i>) for, 328.		
IRON AND STEEL RAILWAY AND TRAMWAY MATERIALS:—		
Motion made (<i>Mr. Fletcher</i>) for return showing particulars of, 479.		
PURFLEET (See "ROADS").		
Q		
QUARANTINE STATION:—		
Motion made (<i>Mr. Lyne</i>) for all papers, letters, &c., in reference to removal of, at North Head, 241;		
Return to Order, laid on Table, 263	2	241
Motion made (<i>Mr. See</i>) for papers, &c., in reference to removal of, 573.		
QUARRIES (See "PARRAMATTA MUNICIPAL QUARRIES BILL"; also "STATE QUARRIES").		
QUEANBEYAN (See "STAMP DUTIES ACT").		
QUEEN, HER MAJESTY THE (See "ADDRESS").		
"QUESTION BE NOW PUT":—		
Motion made, and passed, 24 ⁽²⁾ , 156, 220, 221, 222, 468, 485.		
Do. and withdrawn, 156-7.		
Do. and negatived, 493, 530.		
Do. and Teller's List showing less than forty members in favour of, 468.		
Ruling of Mr. Speaker that when there are no voices for the Noes, having satisfied himself that forty members are present, it is not necessary to take a division, 24; dissent from ruling moved (<i>Mr. Dibbs</i>) and negatived, 25.		
QUESTIONS:—		
AND ANSWERS:—		
Sessional Order passed, 10.		

Q

QUESTIONS AND ANSWERS:—

- ABATTOIRS:—**
Removal of, from Glebe Island, 7, 14.
Leasing of Glebe Island, 206.
Condition and Management of, 213.
Dismissal of Mr. Read from Glebe Island, 333.
- ABERDEEN:—**
Bridge over Hunter at, 559.
- ABIGAIL, THE HON. FRANCIS, M.P.:—**
Ownership of land near Pittwater Tramway, 155.
Sleeping-car for accommodation of, 402.
- ABORIGINES:—**
Occupancy of Moira Forest Reserve by, 122.
River Murray, 285.
La Perouse, 591.
- ACCIDENT:—**
Railway, at Peat's Ferry, 74, 118, 265, 276, 632.
To s.s. "Alhambra," 564.
- ACCOUNTS, PUBLIC (See "FINANCE")**
- ADAMINABY:—**Recreation Reserve, 96.
- ADDISON, MR., STIPENDIARY MAGISTRATE:—**
Complaints against, 167.
Cases dealt with by, at one sitting, 173.
- ADELAIDE:—**Jubilee Exhibition, 94, 133, 134, 190, 262, 495.
- ADMINISTRATION OF JUSTICE:—**
Nominations to the Magistracy, 8(?), 21, 57.
Licensing Magistrates acting on Magisterial Bench, 69, 163.
Stipendiary and Deputy Stipendiary Magistrates, 167, 173, 190, 215, 331.
Regulations for admission to the Bar, 8.
Regina v. Pruen, 8, 79.
Mount Rennie convicts, 28.
District Court Bailiff's, 45.
Sheriff's Bailiffs mileage charges, 209.
Trials in District Courts, 133.
Wilkinson's Australian Magistrate, 45.
Jurors, District Court, Cooma, 68.
Employment by the Government of—
Hon. E. Barton, M.L.C., 80.
Dr. Sly, 101(?), 110.
Sheriff's Officers, 83.
Court of Quarter Sessions, Bombala, 223, 256.
Do. Muswellbrook and Singleton, 218.
Court of Petty Sessions, Manly, 88.
Charge for Subpœnas, 110.
The Attorney-General, 51, 73, 110, 141, 245.
Supreme Court Appeals Act, 117.
Prosecutions before Juries, 139.
Release of Prisoners, Centenary Celebration, 164.
Sentence passed on T. B. Giles, 227.
Fees paid to Mr. John Armstrong, Barrister-at-Law, 255, 262.
Quarter Sessions, Lock-up, and Gaol for Bombala, 256.
Case of J. A. H. Poulton, 265, 377, 384.
Mr. Manning, Coroner at Ryde, 270.
Commission of the Peace, 292.
Alteration in system of summoning Jury List, 312.
Court-house, Lawrence—Court-house, Maclean, 312.
Supersedeas to Bankrupt Justices of the Peace, 319.
Decree *re* Stephen v. Erwin, 332, 511.
Case of Queen v. Bowler, 334.
Furniture for Court-house, Narrabri, 339.
Magistrates, Young District, 341.
Prisoner Holt, 360.
Captain's Flat, Site for Police Court, 367.
Commissioner for Affidavits, Moama, 367.
Court-house, Silverton, 372.
Body, Mr. John E., Cooma, 387.
Court-house, Redfern, 413.
Court of Petty Sessions, Leichhardt, 413.
Police Magistrate at Parramatta, appointment of, 420.
Clerk of Petty Sessions, Murrumburrah, 436.
Case of Dorn v. Dorn, 436.
Visiting Magistrate, Norfolk Island, 436.
Fees of Clerk of Petty Sessions, 449.
Prisoner Healy, 472.
Mr. William Thomas, J.P., of Forbes, 541.
Mr. Giles, P.M., Bombala, 556, 578.
Case tried before Police Magistrate at Lismore, 575.
Court-house, Wilcannia, 577(?).
Cost of Law Suits in which Crown is successful, 598.
Bench of Magistrates, Michelago, 613.
- ADULTERATION OF FOOD AND LIQUORS:—**Bill dealing with, 34.
- ADVERTISING:—**On Tram-motors, 97.
- AGENT-GENERAL:—**Appointment of, 401.

QUESTIONS—(continued):—

- AGRICULTURAL (See also "FARM PRODUCE")**
Show Grounds, Queanbeyan, 56.
Centennial Show, 164.
Resources of various districts, 458.
Societies, 371, 459.
Model Farms, 48, 63.
Schools and Model Farms, 267.
- AHERN, MR. JOHN:—**
Tenders for contract for Cast-iron Syphon, George-street West, 606.
- AIRY, CAPTAIN H. P.:—**Promotion of, to rank of Brevet-Major, 189.
- ALBURY (See also "CROWN LANDS"):—**
Lands Office, 419.
Water Supply Railway Station, 584.
- ALEXANDRIA:—**
Measles and Typhoid Fever in, 111.
Drainage of Borough, 412.
Public School Accommodation, 591.
- "ALHAMBRA" S.S.:—**
Accident to and loss of, 564.
- ALT-STREET, ASHFIELD (See "RAILWAYS")**
- ALLEN, MR. W. J., M.L.A.:—**
Railway Fares of Ladies accompanying to Bourke, 612.
- AMMUNITION (See "MILITARY")**
- ANALYST, GOVERNMENT:—**Appointment of Mr. Hamlet, 34.
- APPEALS:—**Determined under Supreme Court Appeals Act, 117.
- AQUARIUMS:—**Bondi, Cogee, and Manly, 533, 553.
- ARBITRATION CASE:—**
Commissioner for Railways v. The Hon. John Smith, 51, 80, 96, 102.
M'Sharry v. Commissioner for Railways, 37, 96, 319.
The Hon. S. Charles, M.L.C., v. Commissioner for Railways, 101(?), 110.
- ARDILL, MR. JOHN ROCHE:—**Case of, 395.
- ARMIDALE:—**Centennial Celebration, 529.
- ARMOUR PLATE:—**For Defence Works, 205.
- ARMSTRONG, MR. JOHN, BARRISTER-AT-LAW:—**Fees paid to, 255, 262.
- ARNCLIFFE:—**
Public School, 134.
Park, 572.
- ARNHEIM AND MATHESON, MESSRS.:—**Tin Lease of, Silverton, 142.
- ASHFIELD:—**
And Druitt Town Tramway, 57.
Sub-way at Alt-street, 275.
- ASHFIELD STATION:—**Train arrangements, 344.
- ASSAYER:—**Government, and Assistant Assayer, 34.
- ASSAYS (See "MINING")**
- ASSEMBLY:—**
Electric Light in the Chamber, 32, 39, 68.
Hour of Meeting, 207.
Payment of Members of, 256.
- ASSISTANT EXAMINER OF ACCOUNTS, TREASURY:—**Application for position of, 473.
- ASSIGNEES OFFICIAL:—**
Alleged misconduct of, 613.
- ASSOCIATION CRICKET GROUND:—**Trustees of, 447, 518, 541, 569, 589.
- ASSURANCE FUND:—**Real Property Act, 179, 207, 261, 305, 341, 459.
- ASYLUMS:—**
Reports as to management of Government, 7.
Dismissal of Warder Nagle, 21.
Newington, Inquiry, 240, 290.
Newington and Parramatta, 337.
For Insane, Parramatta North, 343, 521.
- ATHENÆUM AT WILCANNIA:—**Subsidy to, 364.
- ATTENDANCE OFFICERS (See "EDUCATION")**
- ATTORNEY-GENERAL:—**
Fees received by, for appearing in Crown Cases, 51, 73, 245.
Patent Fees received by each, since Responsible Government, 110, 141.
Acting Secretary to, 553.
- AUBURN:—**
Crossing at Station, 313.
Park Road Trust, 424.
- AUDIT DEPARTMENT:—**Promotions in, 183.
- AUGER DRILLS:—**Amount due for use of, 261.
- AUSTRALASIAN STEAM NAVIGATION COMPANY:—**
Purchase of Wharf by the Government, 8.
Rumoured purchase of Works, Pymont, by the Government, 8.
Purchase of land between Wharf and Dawes Point, by the Government, 56.

Q

QUESTIONS—(continued)—

AUSTRALIAN AGRICULTURAL COMPANY:—Road through Land at Warrah, 167.
 AUSTRALIAN GASLIGHT COMPANY:—Incorporation of, 106.
 "AUSTRALIAN MAGISTRATE":—Supply of, to Benches, 45.
 BACON DUTY (See "CUSTOMS")
 BAILIFFS:—
 Of District Courts, 45.
 Mileage Rates charged by Sheriff's, 209.
 BALRANALD (See "CROWN LANDS," also "RABBIT PEST")
 BALIS'S SELECTIONS (See "CROWN LANDS")
 BANK PASS BOOKS:—Transmission of, by post, 184.
 BANKERS:—Business of, 400.
 BANKRUPTCY ACT:—Moneys in the hand of Government, 471.
 BANQUET:—Centennial, 256.
 BAR, THE:—Regulations for admission to, 8.
 BARCOM GLEN ESTATE:—Resumption of portion of, 127.
 BARLING MR.:—Length of service of, 142.
 BARRABA (See also "ROADS"):—
 Temporary Common, 167.
 BARRINGUN:—Rabbit-proof Fencing between Bourke and, 218.
 BARTON, Mr. G. B., (See "Official History of New South Wales.")
 BARTON, THE HON. EDMUND, M.L.C.:—Employment of, by the Government, to prosecute, 80.
 BARWON:—Bridge over at Brewarrina, 403.
 BATE'S SELECTION (See "CROWN LANDS")
 BATHURST (See also "RAILWAYS.")
 Railway Station—Over-bridge, 15.
 Do Hay Loading Stage, 81.
 Do Payment of Wages by Stationmaster, 394.
 Railway to Bourke, 535, 564.
 Embankment near Railway Bridge, 81.
 Officers of District Engineer's Staff, 271.
 New Gaol at, 271.
 Burr, Destruction of, 272.
 Employés in Railway Workshops, 290, 428.
 Railway Workshops, 618.
 BEDLAM CREEK (See "BRIDGES")
 BEEB:—Duties paid on, 31.
 BEGA-EDEN RAILWAY:—Plans and books of reference, 332.
 BELABULA (See "ROADS")
 BELAR CREEK:—Road, parish of Deringullen, 168, 340.
 BELL, SUB-INSPECTOR (See "POLICE")
 BELMORE:—Recreation Ground, 292.
 BELMORE PARK:—Tramway crossings, 110.
 BELTBEE'S STATION:—Selections made on, 384.
 BENEVOLENT ASYLUM:—Site for, Parramatta North, 343.
 BETTING SWEEPS:—And "Consultations," 218.
 BILLIARD LICENSE:—
 William Spangenberg's application for, 38 (?).
 District of Marrickville, 270.
 BINGERA:—Crown Lands Sale at, 235.
 BLACKFRIAR'S ESTATE:—Condition of streets and lanes, 427.
 BIRTHS:—District Registrars of, 411.
 BLACK, MR. JOHN:—Property resumed on Homebush-Waratah line, 523.
 BLAYNEY:—Railway Station, 332.
 BLOXSOME, MR. REGINALD:—Appointment of as Secretary Metropolitan Water and Sewerage Board, 368.
 BLUE METAL:—Railway haulage rate, from Emu Plains, 47.
 BOARDS OF INQUIRY:—
 Statistics of, 205.
 Collieries, 489.
 Phylloxera, 490.
 BOARD OF RAILWAY COMMISSIONERS:—Appointment of, 536.
 BOATS:—For Richmond River, 292.
 BODY, MR. JOHN E.:—Appointment of, to Licensing Court, Cooma, 387.
 BOGAN RIVER:—Road from Narramine, 51.
 BOLTON Mr. JOSEPH:—Complaint against Mr. W. H. Margil, 607.
 BOMBALA:—
 Court of Quarter Sessions, 223, 256.
 Lock-up Gaol, 256.
 Mr. Giles, P.M., 556, 578.
 BONDI:—
 Sewer, 126, 154.
 Foreshores of, 134.
 Aquarium, 533, 553.
 BONDED WAREHOUSES:—Kerosene Oil, &c., in, 491.
 BOBE (See "WATER SUPPLY")
 BOREE TO PARKES (See "ROADS")
 BORENORE:—
 Railway Goods Traffic, 559.
 Railway *via*, 597.
 BOBING OPERATIONS:—Clarence Siding, 498.

QUESTIONS—(continued)—

BOTANY:—
 Nuisance of Seaweed at, 32, 70, 333, 412.
 Professor of, and Lectures on, 94.
 Celebration of the Centenary of the Colony at, 117.
 Public Wharves, 411.
 Lighting Road, 412.
 Road, Tram-line, 413.
 Road, 474.
 BOURKE (See also "CROWN LANDS," also "RABBIT PEST"):—
 Prisoners in gaol, 31.
 Customs duties collected at, 38.
 Court-house, 56.
 Disease in Stock in district, 81.
 Railway Goods Charges to Byrock and, 195.
 Post and Telegraph Office, 39, 215, 498.
 Rabbit-proof Fencing between Barringun and, 218.
 Town Common, 284.
 Railway from Bathurst, 564.
 Telegraph to Wanaaring, 541.
 Erection of Wharf, 598.
 BOTCHER AND PARTY (See "MINING")
 BOWLER, QUEEN v. (See "ADMINISTRATION OF JUSTICE")
 BOWRAL:—Railway Station, 472, 558.
 BOXING MATCHES:—Suppression of, 312.
 BOYS REFORMATORY:—Establishment of, 28, 331.
 BRADLEY'S HEAD:—Resumption of Land near, 14.
 BRAIDWOOD:—Post and Telegraph Master at, 473.
 BRAINE, ALFRED:—Timber Inspector, Cooma Railway, 125.
 BRAKES:—Railway, 74, 388, 632.
 BRASS FITTINGS:—For Water Supply purposes, 218.
 BREWARRINA:—
 Customs Duties collected at, 38.
 Bridge over Barwon at, 403.
 BRIDGES:—
 Roads and, in Electorate of The Richmond, 21.
 Iron Cove, 21, 424, 460.
 Middle Harbour, at the Spit, 27.
 River Murray, at Mulwala, 27, 275.
 Over Upper Murray, 34, 275, 301.
 Turon River, at Wallaby Rock, 43.
 Iron for, Roads Department, 62, 213.
 Dilga Creek, Road Cumnock to Baldary, 62.
 Eugowra Creek, 118.
 Moama, over Murray River, 122, 290, 364.
 Mangrove Creek, Hawkesbury River, 149.
 On Road Menindie to Kinchega, 154.
 Wyang Creek, Bedlam Creek, 262.
 Hunter River, at Hillsborough, 275.
 Do at Aberdeen, 559.
 Hawkesbury Railway, 284, 293, 307, 319, 331, 337, 355, 359, 533.
 Duck River, 291.
 Darling at Wilcannia, 311, 528.
 Tarban Creek, 313.
 Over Barwon at Brewarrina, 403.
 Parramatta River, 424.
 Iron, Cost of, 432.
 Narandera, 518.
 Castlereagh River, 611.
 BRIGADE OFFICE (See "MILITARY.")
 BROKEN HILL:—
 Height above sea level, 163.
 Post and Telegraph Offices at, 266, 428.
 BROWN, MR. JOHN (See "CROWN LANDS")
 BROWN, MR. H. H., M.P.:—Horses purchased from by Telegraph Department, 271, 459, 512.
 BROWN, MR. THOMAS (See "CROWN LANDS")
 BRUSH CARBONS:—Supply of, 46.
 BRUSHGROVE:—Trustees for Recreation Reserve at, 121.
 BULGA ROAD:—Alienation of Reserve on Stock Road, 139, 163, 251.
 "BULLETIN, THE":—Alleged prohibition of, in the Barracks, 56.
 BULLI COLLIERY:—
 Report on Disaster at, 7.
 Opinion of Attorney-General, *re* Explosion, 33.
 BUNGAREE NOAH:—Proposed Lighthouse on, 93.
 BUOY:—Off Dobroyd Point, 134.
 BURADOO:—Platform, 518.
 BURGLARIES:—In Western Suburbs, 618.
 BURRABOGIE RUN:—Rent fixed, 84.
 BURRAWONG RUN:—Destruction of Timber on, 52.
 BUTTER DUTY (See "CUSTOMS")
 BUTTERINE:—Sale of, 542.
 BYROCK:—
 Water Supply, 38.
 Town Common, 38, 195.
 Road to Gongolgan, 183, 279.
 Railway Goods Charges to Bourke and, 195.

Q

QUESTIONS—(continued):—

- CABLE COMMUNICATION (See "TELEGRAPHS.")
- CAMPBELL MR. JAMES LANG:—Acting Secretary to Attorney-General, 558.
- CAMPERDOWN:—Application of Municipal Council to borrow, 189, 205.
- CANNELL, MR. E.:—Contract for Road near Stone Quarry Creek Crossing, 105.
- CANLEY VALE PLATFORM:—Officer in charge at, 313.
- CANOWINDRA:—Travelling Stock Reserve on Eugowra Road, 179.
- CAPITATION ALLOWANCE (See "VOLUNTEERS")
- CAPTAIN'S FLAT:—
Village Reserve at, 47, 279.
Purchase of Land at, 154.
Mineral Leases at, 155, 280, 291, 367.
Site for Police Court, 367.
Business Licenses, 607.
- CARCOAR:—Road to Mount Macquarie, 34.
- CARTAGE:—Wool Produce, &c., from Darling Harbour, 546.
- CARELESS USE OF FIRE:—Prosecutions and convictions under, Act, 331.
- CARGO (See also "CROWN LANDS"):—
Land sale at Cheeseman's Creek and, 218.
- CARRINGTON GROUNDS:—Betting and gambling at, 348.
- CARS (See "TRAMWAYS")
- CARVER, MR. NICHOLAS P.:—Railway Surveyor, 96.
- CASINO:—
Payment of the Unemployed by Council, 75.
Prison Labour in Gaol, 490.
Land Board, 497.
- CASSILIS:—
Railway Extension beyond, 79.
Railway Trial Survey from Singleton, *via* Jerry's Plains, 448.
Railway from Muswellbrook, 556, 559.
- CASTINGS (See "HARBOUR AND RIVERS DEPARTMENT NEWCASTLE")
- CASTLEREAGH RIVER:—Bridge over, 611.
- CASUAL LABOUR BOARD:—
Particulars of, 33.
Expenditure of, &c., 125.
- CATTLE:—Regulations respecting, sent from New South Wales to Victoria, 180.
- CATTLE TRUCKS (See "RAILWAYS")
- CAVALRY CORPS:—Uniforms, &c., for Country, 497.
- CAVANOUGH, FREDERICK:—Appointment to the Railway Department, 428.
- CEMETERIES:—
Devonshire-street, 84, 101.
Rookwood and Waverley, C.E. Chaplains, 141.
Presbyterian, Liverpool, 227, 235.
- CENTENARY OF THE COLONY (See also "MELBOURNE EXHIBITION"):—
Celebration at Botany, 117.
Competition in Designs for State House, 155.
Release of Prisoners, 164.
Agricultural Show, 164.
Banquet, 256.
Relief to Poor of Sydney, 291.
Medals for Commissioners, 301.
Authority for payment of cost of State House, 355.
State House, Erection of, 383.
Celebrations, 424.
Railway Return Tickets issued in connection with Exhibition, 448.
Armidale Celebration, 529.
- CENTENNIAL (See "CENTENARY OF THE COLONY")
- CENTENNIAL PARK:—
Land taken from Sydney Common, 300.
Amount paid in connection with, 352.
Gateways to Borough of Waverley, 478.
- CENTRAL POLICE OFFICE:—Officers in, 223.
- CHANGING-PLACES (See "RAILWAYS")
- "CHANGSHA," S.S.:—Illegal landing of Chinese from, 395.
- CHAPLAINS:—Church of England, Rookwood and Waverley Cemeteries, 141.
- CHEESE DUTY (See "CUSTOMS")
- CHEESEMAN'S CREEK:—Land Sale at Cargo and, 218.
- CHICKEN CHOLERA (See "RABBIT PEST")
- CHINESE:—
Employment on Relief Works, 16.
Restriction of Immigration, 20.
Naturalization of, 63.
Visit of Commissioners, 95.
Tram Time-tables in language, 333.
Fine for illegally landing from s.s. "Changsha," 395.
- CHLOROFORM:—Deaths while under influence of, 270.
- CHRISTMAS DAY:—Opening public-houses on, 227.

QUESTIONS—(continued):—

- CHURCH AND SCHOOL LANDS DEDICATION BILL:—Introduction of, 33.
- CHURCH AND SCHOOL LANDS:—
Introduction of Bill for Mining on, 313, 377.
Dedication Bill, 557.
- CIRCULAR QUAY:—
Extension of Railway to, 178.
Quit-rent on Cunninghame's Grant, 184.
Wood-paving, 301.
Mr. Norman Selve, Improvements at, 388.
- CITY:—Railway from Redfern into, 512.
- CIVIL SERVICE:—
Department of Public Works, 13, 142.
Department of Lands, 13.
Department of Mines, 21, 33.
Department of Audit, 183.
Superannuation Fund, 38.
Registrar-General's Department, 63.
Customs Department, 75, 110, 143.
Telegraph Department, 111, 529.
Salaries of Clerks of Petty Sessions, 134, 235, 474.
Regulation fixing Hours of Attendance, 149.
Mr. Thomson, Chief Inspector of Accounts, 153.
Clerks in Roads Department, 168.
Mr. Macarthur, late P.M., Corowa, 180.
Comparative Statement of Salaries and Wages, 207.
Deductions from Salaries of, 223, 324.
Mr. Foskett, Stamp Office, 214, 299.
Officers in Central Police Office, 223.
Police Magistrates appointed Wardens under the Mining Act, 227, 245.
Commission to enquire into, 245, 511.
Vouchers for moneys paid by Public Officials, 251.
Holidays in General Post Office, 272, 356, 489, 556.
Mr. Samuel Hawthorne, employment of, 283.
Salaries paid at same rates as 1887, 293.
Mr. O'Malley Clarke, leave of absence, 299, 351.
Appointment of Locomotive Engineer, 327, 477, 484.
Mr. Yates, leave of absence, 351.
Mr. Dalglish, district surveyor, 352.
Salaries for month of March, 356.
Public Holidays for Classified Officers of Railway Department, 402.
Mr. Charles Cutcliffe, Clerk of Petty Sessions, Murrumburrah, 436.
Fees to Clerks of Petty Sessions, 449.
Annual increase to salaries of certain, 454.
Salaries, Pension Fund, 460.
Assistant Examiner of Accounts, Treasurer, 473.
Removal by Mr. A. Moriarty of pay-sheets from Harbours and Rivers Department, 495.
Mr. G. S. Ridley, 522.
Messrs. G. F. Wise and F. B. Treatt, 534.
Mr. C. Colls, Railway Department, 536.
Mr. James Lang Campbell, 558.
Persons entitled to Pensions, 591.
Appointments of sons of Ms.P. to, 606.
Officers in Public Instruction Department over age of 60 years, 633.
Increments to Salaries of Telegraph Operators, 634.
- CIVIL SERVICE ACT:—
Provision for Officers about retiring in event of repeal of, 94.
Actuaries consulted when framing, 214.
Refund of contributions, 324.
Actuarial investigation into state of Superannuation Account, 324.
Salaries and Pension Fund, 460.
- CLARENCE RIVER:—
Local Land Board, 55.
Seed Potatoes supplied to persons in Electorate, 171.
Improvements at, 324.
- CLARENCE SIDING:—
Diamond Drill at, 102, 190, 207.
Boring operations, 498.
- CLARKE, MR. O'MALLEY:—Leave of absence, 299.
- CLARKE, MR. WILLIAM, M.P.:—Appointment of as Agent-General, 401.
- CLERKS OF PETTY SESSIONS:—
Salaries of, 134, 235, 474.
Fees under Act, 449.
- CLIBBORN, MR.:—Railway Free Pass to, 385, 401, 440.
- CLIFFORD, MR. J. J.:—Appointment of, as J.P., 8.
- CLOAK ROOM:—
Sydney Railway Station, 545.
- COAL (See "RAILWAYS," also "MINING")
- COAL CLIFF COLLIERY COMPANY:—Connection of Mr. Charles Cowper, Sheriff, with, 111.

INDEX.

REFERENCES TO THE VOTES AND PROCEEDINGS, VOL. I.—13TH PARLIAMENT—SESSION, 1887-8.

Q

QUESTIONS—(continued) :—

COAL-FIELDS (See also "COLLIERIES") :—
 Mr. Mackenzie, Examiner of, 7, 14, 20, 33 (2).
 COAL-MINES REGULATION ACT :—Amending Bill, 14.
 COBAR (See also "WATER SUPPLY") :—
 Railway from Nyngan, 215.
 Mineral Leases, District of, 458.
 COBARGO :—Post and Telegraph Office, 96.
 COHEN, Mr. E. N. :—Promotion of, in Central Police Office, 223.
 COLLIERIES :—
 Report on Bulli Disaster, 7, 33.
 Board of Inquiry into, 489.
 COLLS, Mr. C. :—Railway Department, 536.
 COLONIAL AND INDIAN EXHIBITION :—Expenditure on, 126.
 COLONIAL IRON :—Result of tests, 167.
 COLONIAL SECRETARY :—Visit of, to Northumberland, 9.
 COLONY :—Change in name of, 184.
 COLO VALLEY :—Railway Trial Survey by way of, 80, 266, 319.
 COMBINATION TRUCKS (See "RAILWAYS")
 COMMISSIONS :—
 Adelaide Jubilee Exhibition, 133.
 Statistics of Royal, 205.
 To enquire into Civil Service, 245, 511.
 Destruction of Rabbits, 290.
 Melbourne Exhibition, 372.
 Secretary, Rabbit Pest, 406.
 Transit, 457.
 Intoxicating Drink Inquiry, 460.
 COMMISSION :—Of the Peace, 292.
 COMMISSIONERS (See also "TRANSIT COMMISSIONERS," also "RAILWAYS") :—
 Adelaide Jubilee Exhibition, 94, 134, 190, 262, 495.
 COMMISSIONER FOR AFFIDAVITS :—Moama, 369.
 COMMONS :—
 Town, Byrock, 38, 195.
 Do. Bourke, 284.
 Moama, 164.
 Temporary, Barraba, 167.
 Do. Albury, 261.
 Richmond, 214.
 Wallabadah, 337.
 Pillaga, 339.
 COMPENSATION :—Improvements, under Crown Lands Bill (No. 2), 364.
 CONDITIONAL PURCHASES (See "CROWN LANDS")
 Returns respecting, 395.
 CONDOBOLIN :—
 Schools near Railway Line to, 558.
 Post and Telegraph Office, 559.
 Railway Line to, 575, 605, 617.
 Land Board, 592.
 CONFERENCE :—Destruction of Rabbits, 364, 372.
 CONSERVATION OF WATER :—
 Supervision of Construction of Tanks, &c., 61.
 Carrying out proposals of Royal Commission, 172.
 CONSOLIDATED REVENUE FUND (See "FINANCE")
 CONSOLIDATED REVENUES :—Of Great Powers of Europe, America, Canada, and Australasian Colonies, 109.
 CONSTRUCTION OF LOCOMOTIVES :—
 By the Baldwin Company, 327.
 In the Colony, 6, 47, 110, 144, 413, 480, 495.
 "CONSULTATIONS" :—And Betting Sweeps, 218.
 CONTESTS (See "EXHIBITION CONTESTS")
 CONTRACTORS :—Payment of Road, 39.
 CONTRACTS :—
 Given to Messrs. Hudson Bros., without competition, 69.
 Payments under, to Messrs. Kidman, 272.
 Postal, with Pacific Mail Steamship Company, 239, 319.
 Road, Mr. Wells, 448.
 CONVICTS (See "ADMINISTRATION OF JUSTICE")
 COOK'S RIVER :—
 Flooding of Marrickville and Tempe through Railway Bridge over, 179.
 Reclamation Work, 262.
 COODE, SIR JOHN :—
 Improvements at Clarence River, 324, 498.
 Improvements, Richmond River entrance, 458.
 Report on Crookhaven Heads, 572.
 COOGEE BAY :—
 Sea-wall at, 106.
 Aquarium, 533.
 COOKSON, Mr. :—Schoolmaster at Seven Hills, 528.
 COOLE, EDWARD :—Railway Ticket Collector, 293.
 COOMA (See also "RAILWAYS") :—
 Jurors, District Court, 68.
 Recreation Ground, 96.
 COONABARABRAN (See "CROWN LANDS")

QUESTIONS—(continued) :—

COONAMBLE :—Road to Pilliga, 339.
 COOTAMUNDEA :—Post and Telegraph Master at, 473.
 COPYRIGHT :—Correspondence respecting application of Imperial Statute, 173.
 COROWA :—
 Mr. Macarthur, late Acting Police Magistrate at, 180.
 Police Barracks, 395.
 COSTS (See "ADMINISTRATION OF JUSTICE")
 COUNSEL'S FEES :—Paid to Attorney-General, 51, 73.
 COUNTRY DISTRICTS :—Public Expenditure in Sydney and, 7.
 COUNTRY TOWNS :—Stray Cattle in, 33.
 COUNTY RESERVE CORPS (See "MILITARY")
 COURT-HOUSE :—
 Bourke, 56.
 Eastern Suburbs, 96, 168.
 St. Albans, 178.
 Junee, 184.
 Lawrence, 312.
 McLean, 312.
 Narrabri, 339.
 Silverton, 372.
 Redfern, 413.
 Wilcannia, 577 (?).
 COURT OF PETTY SESSIONS :—Manly, 88.
 COURTS OF QUARTER SESSIONS :—
 Muswellbrook and Singleton, 218.
 Bombala, 223.
 COUSINS, Mr. R. :—Land sold by the Government to, 184.
 COWPER, MR. CHARLES, SHERIFF :—Action of, in connection with Coal Cliff Colliery Company, 111.
 COWRA :—
 Licensing Bench, Refusal of license to Mr. Galvin, 396.
 Railway Goods Traffic, 559.
 COX'S RIVER :—Survey of Railway to Oberon, *via*, 343.
 CRACE, E. K. :—Road through Estate of, at Gungahleen, 139, 140, 436.
 CRACKNELL, Mr. :—
 Operating Room, Telegraph Department, 453.
 Cable for Frieze-work, 453.
 CREED, Dr. :—Speech on Defences of the Colony, 522.
 CREMOBNE :—Reservation of Shores of Robertson's Point, 153.
 CRICKET GROUND (See "ASSOCIATION CRICKET GROUND")
 CROOKED CREEK :—Proposed Works at, 618.
 CROOKWELL :—Railway from Goulburn, 88, 450.
 CROSSING AT AUBURN STATION :—Dangerous state of, 313.
 CROWN LANDS (See also "RESERVES") :—
 Department, 13, 270.
 Over-payment of Rent by Pastoral Tenants, 14.
 Rental of Pastoral Leaseholds and Resumed Areas in Central District, 88.
 Pastoral and Homestead Leases, Western Division, 105.
 Pastoral and Homestead Leases, Rent from, 189.
 Arrears of Rent for Runs, 149, 255.
 Arrears due by Pastoral Lessees, 408.
 Runs and homestead leases abandoned and improved land taken up under Act of 1884, 150.
 Transfers of Conditional Purchases, 154, 172.
 Unleased Runs in Western Division, 178.
 Occupation Licenses, 178.
 Pastoral Leases and Occupation Licenses, 207, 472.
 Assessment on Runs in Monaro District, 235.
 Revenue, District of Inverell, 15, 122, 344, 363.
 Do Districts of Warialda, Bingera, and Moree, 102.
 Local Land Board and Survey Office, Wagga Wagga, 28, 261.
 Local Land Boards, 439.
 Dubbo Land Office, 31.
 Clarence River Local Land Board, 55.
 Report Lismore Land Board on working of Act, 83.
 Land Board at Casino, 497.
 Expenses and work of Local Land Boards, 96.
 Local Land Board, Inverell, 376.
 Local Land Board Grafton, 376.
 Land Court, Richmond River, 83.
 Burrabogie Run, 84.
 Reserves in Eastern and Central Districts, 307.
 Resumed Area of Western Division, 189.
 Conditional Purchases, Yarralumla, 154.
 Do Richmond River District, 126, 207.
 Do Denis Morrissey's, 189.
 William Skene's Prelease at Conargo, 143.
 Millgate *v.* the Hon. John Smith, 149, 272.
 Purchase of, Captain's Flat, 154.
 Sale at Cheeseman's Creek and Cargo, 218.
 Sale, Bingera, 235.
 Reserves, Bulga Road, 251.

Q

QUESTIONS—(continued):—

- CROWN LANDS, &c.**—(continued):—
 Crown Lessees, refund of Rents to, 256, 360.
 Forfeited Conditional Purchases re-selected, 256, 290.
 Temporary Common, Albury, sale of lands, 261.
 Maps missing from the Survey Office, 261.
 Land adjoining Racecourse at Cargo, 262.
 Planting Trees on Forest Reserves, 270.
 Reserves made in 1886 and 1887, 284.
 Payment of Interest and Instalments in various Land Districts, 280, 290.
 Ringbarking, 290.
 Application of Mr. Thomas Brown, of Garra, near Molong, 313.
 David Pollack's selection of Forfeited Conditional Purchase, Nangus, 318.
 Runs forfeited since passing of Land Act of 1884, 340.
 Land Revenue, district of Inverell, 344.
 Rents from, Balranald, Wentworth, and Bourke, 347.
 Land for sale at Molong, 348.
 Reserve Maloga, 364.
 O'Riel and Patterson, application for land at Dubbo, 376.
 Application of John Brown for land at Garra, 377.
 Belltrees Station, Selections made on, 384.
 Conditional Purchases, Land Office, Molong, 395.
 Mrs. O'Dwyer's Selection at Burrowa, 399, 401.
 Bates's Selections, on Pullawing Station, Gunnedah, 401.
 Pastoral Rents Eradication of Prickly-Pear, 403.
 Mr. F. G. A. Trollope, 406.
 Forfeited Selection of John Harrison, of Lismore, 431.
 Mortgages of Pastoral and Homestead Leases, 441.
 Lands Office, Albury, 419.
 Statistics, 461.
 Pastoral Holdings on Lines of Railway. Trial Surveys, 461.
 Pastoral Holdings, Eastern Division, 483.
 Conditional Purchases made by Mr. and Mrs. Poole and the Misses Parnell, 517.
 Mr. G. S. Ridley, 522.
 Forfeited Conditional Purchases, Coonabarabran, 545.
 Land Alienated in Forbes District, 558.
 Conditional Purchases taken up in Parkes and Molong, 577.
 Mr. Park, Chief Commissioner at Hay, 578.
 Lease of Protestant Hall, Dubbo, for Lands Office, 590.
 Runs held by the Messrs. White in the Upper Hunter Electorate, 591.
 Moree Land Board, 592.
 Condobolin Land Board, 592.
 Quan's Selection, North Arm Tweed River, 605.
 Refund to Conditional Leaseholders, 607.
 Extension of Lands Office, 633.
CROWN LANDS BILL (No. 2):—Compensation for Improvements, 364.
CROWN LANDS ACT OF 1884:—
 Land exchanged under 75 sec., 405.
 Fencing Clauses, 523.
 Rents, 542 (2).
 Conditional Leases under 52nd clause, 542.
 Extension of time to Pastoral Lessees, 556.
 Permits to mine for Silver and other Minerals, 564.
 Crown Tenants Appeals, 564.
CROWN LESSEES (See "CROWN LANDS")
CROYDON:—
 Railway Station, 106.
 Park, 356.
CUDAL:—Road to Davy's Plains, *via* Tapp's, 81, 280.
CUMBERLAND DISEASE:—M. Pasteur's Investigations, 460.
CUMNOCK:—Public School, 395.
CUNNINGHAM'S GRANT, CIRCULAR QUAY:—Payment of Quit Rent on, 184.
CURRAN:—Dismissal of, from Telegraph Department, 431.
CUSTOMS:—
 Duties on wines, spirits, and beers, 31.
 Duties collected at towns on River Darling, 38.
 Appointment of the Treasurer's son-in-law to, 75.
 Reduction in Staff since abolition of *ad valorem* duties, 110.
 Position and promotion of Mr. Powell, jun., 143.
 Imperial Copyright Statute, 173.
 New Zealand Import Duty on Grapes, 240.
 Duties on Butter, Bacon, Cheese, and Timber, 307.
 Duty on Timber, 347.
 Kerosene, Oil, &c., in Bonded Warehouses, 491.
 Duties, 581, 611.
 Imports and Exports between South Australia and New South Wales, 582.
CUT WOOD:—Railway rates on, 399.
CUTCLIFFE, MR. CHARLES (See "ADMINISTRATION OF JUSTICE")

QUESTIONS—(continued):—

- CYCLING**:—On Sundays at Lithgow, 478.
DALGLISH, MR. DISTRICT-SURVEYOR:—Leave of absence, 352.
DAMS AND TANKS:—Eastern and Western Districts, 461.
DARLING HARBOUR:—
 Storage of meat at, 75.
 Dépôt for Farm Produce, 102, 140, 191, 240, 271.
 Farm Produce received at, 127, 217.
 Railway Sheds, 144.
 Government Meat Market, 285.
 Farm Produce Market, 399.
 Cartage of Wool, Produce, &c., 546.
DARLING POINT:—Drainage from, 127.
DARLING RIVER:—
 Customs Duties collected at towns on, 38.
 Bridge over, at Wilcannia, 311.
DARLING-STREET WHARF (See "TRAMWAYS")
DAVY'S PLAINS:—Road, Cudal to, *via* Tapp's, 81, 280.
DAVES POINT:—Purchase of land adjoining, by the Government, 56.
DEAN, THOMAS:—Summoned under Public Instruction Act, 61.
DEATHS:—While under influence of Chloroform, 270.
DECREE (See "STEPHEN v. ERWIN")
DEDICATION:—Nandi Flat, Castlereagh River, 340.
DEFENCES (See also "MILITARY") :—
 Iron armour plate for works, 141, 205.
 Storage of Gun-cotton, 143.
 Of the Colony, 289, 367, 402.
 Dr. Creed's Speech, 522.
DELOHERY, MR.:—Deputy Stipendiary Magistrate, 331.
DEMURAGE:—Charges for, 564.
DENILIQUIN:—Mr. Scott, Police Magistrate, at, 173.
DEPOSITS (See "SAVINGS BANKS")
DÉPÔT FOR FARM PRODUCE:—Darling Harbour, 102, 140, 191, 240.
DE SAILLY & Co.:—Money due to under Rabbit Act, 557.
DEVONSHIRE-STREET CEMETERY:—
 Closing of—Trustees for, 84.
 Interments in, 101.
DIAMOND DRILLS:—
 In use at Clarence Siding, 102, 190, 207.
 Amounts due to the Mines Department for Augerand, 261.
DIFFERENTIAL RATES (See "RAILWAYS")
DILGA CREEK:—Bridge over, 62.
DISEASED CATTLE:—Sale of, 20.
DISEASE IN STOCK:—
 District of Bourke, 81.
 Throughout Colony, 262.
DISTRICT COURTS:—
 Abolition of offices of Bailiffs, 45.
 Precedence of Trials in, 133.
DISTRICT ENGINEER'S STAFF AT BATHURST:—Officers of, 271.
DOBROD POINT:—
 Buoy fixed near, 134.
 Lives lost at, 134.
DOGS:—
 Number registered, 51.
 Prosecutions for non-registration subsequent to registration, 190.
 Registration of, Maitland, 191.
DOMAIN:—
 Exclusion of the public from, 213.
 Government, 369.
DORN v. DORN:—Case of, 436.
DOUBLE BAY:—Seaweed nuisance, 110.
DRAINAGE:—
 From Darling Point, 127.
 Borough of Alexandria, 412.
 Western Suburbs, 546, 634.
 Marrickville, 633.
DREDGING:—
 In front of Mr. Ellis's property at Pymont, 111, 126.
 Dredge for Shellharbour, 195.
 Dredge for Tweed River, 276, 575.
DRINK INQUIRY COMMISSION:—Second and Final Report, 460.
DRUITT TOWN:—Tramway from Ashfield, 57.
DRUMMOYNE:—Leasing of wharf, 173, 190.
DUBBO:—
 Land Office, 31.
 Railway to Bourke, 420.
 Engine-sheds and changing-places at, 503.
 Protestant Hall, 590.
DUCK RIVER (See "BRIDGES")
DULWICH HILL:—Tramway, Marrickville to, 134, 633.
DUPLICATION OF LINE (See "RAILWAYS")
DUTIES (See "CUSTOMS")

Q

QUESTIONS—(continued):—

- DUXFORD ESTATE, GLENMORE ROAD:—Applications for licenses for public-houses, 407.
- DYNAMITE:—Use of, to destroy Fish, 447.
- EASTER ENCAMPMENT (See "MILITARY," also "VOLUNTEERS")
- EASTERN SUBURBS:—
Court-house for, 96, 168.
Sewerage of, 16, 164.
- EDUCATION:—
Case of Thomas Dean, 61.
Compulsory Clauses of Public Instruction Act, 73.
School Attendance Officers, gratuities to, 74.
Candidates for employment in Provisional Schools, 95.
Public School, Arncliffe, 134.
Do Tibobourra, 177.
Do Cumnock, 395.
Sickness in Public Schools, 214.
Pooncarie School, 317.
Examination Fees, University of Sydney, 347.
Milparinka, Public School at, 364.
Public Schools, Assistant Teachers, 388.
Prosecutions under Public Instruction Act, 406, 435.
Public School Fees, 407.
Veterinary School, 395.
Board of Technical, 423, 503, 577, 606 (?), 607, 630, 631.
Technical, 428, 552, 577, 606, 619, 630, 631.
New School, Pitt Row, Parramatta, Master of, 423.
Resumption of Land, High School, Elizabeth-street, Public School, Castlereagh-street, 424.
Public, 431.
Miss Sutherland, Public School, Cooma, 436.
Rock Flat Public School, 437.
Training School, in connection with Department, 484.
Fuel in Schools, 523.
Mr. Cookson, Schoolmaster at Seven Hills, 528.
Department of Engineering, Sydney University, 497.
Church and School Lands, 313, 377, 557.
Schools near Railway Line to Condobolin, 558.
Public Instruction Act, cleaning Schools, 572.
Training Institution for Teachers, 583.
Polytechnic College, 584.
Public School accommodation, Borough of Alexandria, 591.
Complaint of Mr. Joseph Bolton against Mr. W. H. Margil, 607.
Officers in Department over age of sixty years, 633.
- ELECTORAL:—
Introduction of Bill limiting number of Members, 33.
Revenue derived from the Namoi Electorate, 235, 363.
Rolls for 1887-8, 251.
Rolls, 435, 436, 441.
- ELECTRIC (See also "TORPEDO," also "TELEGRAPHS"):—
Light in Legislative Assembly Chamber, 32, 39, 68.
Motors for Tramways, 56.
"Gulcher" Light Apparatus, 74, 106, 272, 305, 373.
Armoured Cable, 87.
Light Apparatus, 518, 584.
Lighting Macquarie Light-house, 518, 632.
- ELLIS, MR. J. C., M.P.:—Dredging in front of property of, Pyrmont, 111, 126.
- EMMAVILLE:—Railway rates on merchandise, 394.
- EMPLOYEES:—
(See also "RAILWAYS," also "TRAMWAYS," also "TELEGRAPHS")
Re-employment of Dismissed Government, 523.
- ENDOWMENT:—
Pro rata to contributions from non-resident ratepayers, in Municipalities, 173.
Schools of Arts and Mechanics' Institutes, 534.
On contributions for Municipal purposes, 477.
To Municipalities, 570, 634.
- ENGAGED COMPARTMENTS (See "RAILWAYS")
- ENGINEER:—For Railway Trial Surveys, 291.
- ENGINEERING DEPARTMENT:—University of Sydney, 497.
- ENGINES (See "RAILWAYS")
- ENTRANCE TO RICHMOND RIVER:—Improvement of, 276.
- ERWIN, STEPHEN, v.:—Decree, 332, 511.
- ESKBANK:—Station-master, 450.
- ESTIMATES, THE:—Consideration of, 369, 388, 394.
- EUGOWRA:—
Road to Forbes, 57.
Bridge over Creek, 118.
Travelling stock reserve on Canowindra Road, 179.
- EURIOWIE:—Water Supply for, 80.
- EVANS'S COMBINATION TRUCK:—Purchase of patent by the Government, 27, 32, 34, 39, 63.
- EVELEIGH (See "RAILWAYS")
- EXAMINATION FEES (See "UNIVERSITY OF SYDNEY")
- EXAMINERS OF TITLES:—Office hours and leave of absence, 63, 333.

QUESTIONS—(continued):—

- EXHIBITION:—
Adelaide Jubilee, 94, 133, 134, 190, 262.
Indian and Colonial, 126.
Melbourne, 372, 415.
Paris, 581.
- EXHIBITION CONTESTS:—Scenes at, 256.
- EXPENDITURE (See also "FINANCE")
Of Public Money in Sydney and Country Districts, 7.
On local and national works, The Hastings and Manning Electorate, 101.
Authorized and supplementary for 1887, 405.
- EXPORTS (See "CUSTOMS")
- FARES AND FREIGHT (See "RAILWAYS")
- FARM PRODUCE:—
Depôt for, Darling Harbour, 102, 140, 191, 240, 271.
Received by Railway at Darling Harbour, 127, 217.
Market at Darling Harbour, 399.
- FARMS:—Model, 48, 63, 267, 323.
- FEES (See "ATTORNEY-GENERAL," also "ARMSTRONG, MR. JOHN, BARRISTER-AT-LAW," also "UNIVERSITY OF SYDNEY," also "CLERKS OF PETTY SESSIONS")
- FEDERAL REVIEW (See "MILITARY")
- FENCING (See "CROWN LANDS ACTS OF 1884")
- FERRIES:—
Leasing of, at Menindie, 154.
Government, 428, 432.
- FIELD OF MARS:—Tramway, 240, 266, 343, 598.
- FINANCE:—Consolidated Revenues of various countries, 109.
Public Works Loan Act of 1884, 518, 528.
The Estimates, 369, 388, 394.
Public Revenue and Expenditure, 373, 377, 385, 571.
Public Loans, 393, 396.
Railway Loans, 396.
Public Accounts, 396.
Authorized and Supplementary Expenditure for 1887, 405.
Financial Statement, 414.
Assistant Examiner of Accounts, 473.
Consolidated Revenue Fund, 590.
Treasurer's Advance Account, 590.
- FINCHAM, MR.:—Promotion of, in Central Police Office, 223.
- FIRE:—Careless use of, 331.
- FIRE BRIGADES ACT:—Contribution of Insurance Companies towards working, 84.
- FIREWORKS:—Exclusion of the public from the Domain on occasion of, 213.
- FISH:—Use of dynamite to destroy, 447.
- FISHERIES ("See also "NET-FISHING"):
Introduction of Bill to amend Act, 110.
Abolition of Board and reorganization of Department, 206.
- FORBES:—
Railway line to, 521, 611.
Road to Eugowra, 57.
Lands alienated in District of, 558.
Municipal Revenue, 559.
Public Buildings in, 577.
Publican's Licenses, 582.
Deposits, &c., in Savings Bank, 582.
Public Money spent in, 582.
Horses and cattle in District, 582.
Miners' Rights and Business Licenses in District, 583.
Land and Revenue Statistics, 590.
Municipal Chambers at, 611.
- FORESHORES:—Waverley and Bondi, 134.
- FORESTS:—
Destruction of timber on Burrawong Run, 52.
Planting trees on reserves, 270.
Reserve, Terania, 307, 458.
- FOSBERY, MR.:—Seat on Transit Commission, 457.
- FOSKETT, MR.:—Stamp Office, 214, 299.
- FREDERICK, CAPTAIN:—Coast-going Certificate of, 81, 97, 133.
- FREE PASSES:—
Permanent, 16, 453.
To Unemployed, 20.
To Officials of Railway Department, 68, 411.
To Major Taunton, 121.
To Major Staunton, 134.
To Mr. Clibborn, 385, 401, 440.
To Wesleyan Ministers, 457.
To Salvation Army Officer, 461.
- FRIENDLY SOCIETIES ACT:—Annual Returns under, 279.
- FRIEZE-WORK:—
For telephonic system in George-street, 7, 265.
Cable for, 46, 127, 265, 453, 474, 490, 540.
- FUEL IN SCHOOLS:—Supply of, 523.
- FUNDS (See "TRUST FUNDS")

Q

QUESTIONS—(continued):—

FURNITURE :—Court-house, Narrabri, 339.
 GALATHERA AND BOGGY CREEK TANK :—Reserve at, 415.
 GALVIN, MR. :—Refusal of Cowra Bench to grant license to, 396.
 GAOLS :—
 Bourke, 31.
 Bombala, 256.
 New, at Bathurst, 271.
 Casino, Prison Labour, 490.
 GARDEN ISLAND :—Imperial buildings on, 127.
 GARRETT & GREVILLE, MESSRS. :—Mineral Leases held by, 498.
 GARRETT, MR., M.P. :—Mineral lands held by, 540, 575, 592.
 GARSED, MR. JOHN :—Letters addressed to Attorney-General, 63.
 GASLIGHT COMPANY :—Incorporation of Australian, 106.
 GENERAL POST OFFICE (See "POSTAL") :—
 Formation of street north of, 396.
 GERMANS :—In Samoa, 20.
 GERMANTON :—Water supply for, 395.
 GERSBECH, JOSEPH (See "ROADS")
 GIBSON, MR. R. :—Tender for castings for Harbours and Rivers Department, Newcastle, 291, 307.
 GILES, T. B. :—Mitigation of sentence passed on, 227.
 GILES, MR. :—Police Magistrate Bombala, 556, 578.
 GLADESVILLE :—
 Post-office accommodation, 121.
 Lock-up and Quarters at, 267.
 Telegraph Office, 267.
 Mr. Thomas, formerly inmate of Asylum, 402, 473.
 Alignment of streets at, 598.
 GLEBE ISLAND ABATTOIRS :—
 Removal of, 7, 14.
 Leasing of, 206.
 Condition and management of, 213.
 Mr. Read, 333.
 GLEN INNES :—
 Railway rates on merchandise, 394.
 Postmaster at, 612.
 GODDARD, MRS. M., OR BAKER :—Police proceedings against, 447.
 GOLD :—
 Prospecting Vote for, 84, 189, 327.
 Mining and Mineral Leases, 105.
 Fields—Wardens, 227, 245.
 GONGOLGAN :—Road to Byrock, 183, 279.
 GOODS TRAFFIC (See "RAILWAYS")
 GORE'S BAY :—Island at entrance of, 578.
 GOULBURN :—
 Site for Church of St. Saviour, 87.
 Railway to Crookwell, 83, 450.
 Duplication of Railway Line to Cooma Line Junction, 317.
 GOVERNMENT (See also "TRAMWAYS")
 Land purchased by in Parramatta, 8.
 Purchase of A.S.N. Co.'s Wharf and land adjoining by, 8, 56.
 Rumoured purchase of Russell's Wharf, and A.S.N. Co.'s Works, Pymont, by, 8.
 Property resumed in Macquarie-street and Domain, 19.
 Land purchased by, at Macdonaldtown, 32.
 Steam launches, 143.
 Land sold to Mr. R. Cousins, 184.
 Purchase of Statuary, 227, 592.
 Railway Policy, 257, 284, 384.
 Meat Market, 235.
 Domain, 369.
 Ferries, 428, 432.
 Property, Municipal Rates, 473.
 Printing Office, 483, 583, 612.
 Re-employment of dismissed employes, 523.
 GOVERNMENT ASYLUMS :—Reports as to management of, 7.
 GOVERNMENT GAZETTE :—Supply to Schools of Arts, 245.
 GRAIN :—Cost of carrying by Northern Railway, 293.
 GRAFTON :—
 Local Land Board, 376.
 Post and Telegraph Master at, 473.
 GRANTS :—(See "MUNICIPAL," also "ROADS")
 GRANVILLE :—
 Postal accommodation, 102.
 Duplication of line from Penrith, 323.
 Duplication of line from Liverpool, 331.
 Delay of Mail Train, 612.
 GRAPES :—
 New Zealand Import Duty, 240, 251.
 Importation of, into Victoria, 256.
 Board of Inquiry into Phylloxera, 490.
 Phylloxera in County of Cumberland, 582.

QUESTIONS—(continued):—

GRAVEL :—Railway haulage rate from Penrith, 68.
 "GULCHER" ELECTRIC LIGHT APPARATUS :—Purchase of, 74, 106, 272, 305, 373.
 GREVILLE & GARRETT :—Mineral Leases held by, 498.
 GUARDS (See "TRAMWAYS")
 GUN-COTTON :—Storage of, 143.
 GUNNEDAH (See "ROADS")
 GUNPOWDER :—Establishment of a manufactory, 14.
 HALLOBAN, CASE OF JOHN :—At Sydney Hospital, 257.
 HAMLET, MR. :—Government Analyst, 34.
 HANSARD :—
 Reporting Staff, 240.
 Supply of, to Schools of Arts, 245.
 HARBOURS AND RIVERS DEPARTMENT :—
 Castings for Newcastle, 291, 307.
 Pay Sheets taken from, 495.
 HARRIS PARK :—Railway platform, 105
 HARRISON, JOHN :—Forfeited selection at Lismore, 431.
 HASTINGS AND MANNING ELECTORATE :—Expenditure on local and national works in, 101.
 HAWKESBURY RIVER :—
 Net-fishing, 262, 314.
 Railway Bridge, 284, 293, 307, 319, 331, 337, 355, 359, 533, 590.
 Do Medical attendance to employes at, 414.
 HAWTHORNE, MR. SAMUEL :—Appointment of, 283.
 HAY :—Mr. Park, Chief Commissioner, Crown Lands at, 578.
 HEALTH OFFICER :—Watson's Bay, 448.
 HEALY, PRISONER (See "ADMINISTRATION OF JUSTICE")
 HELZINGER, MR. A. :—Suspension of in Railway Department, 32.
 HESSIAN FLY :—Introduction of, 415.
 HILLSBOROUGH (See "BRIDGES")
 HISTORY, OFFICIAL, OF NEW SOUTH WALES :—Publication of new edition, 191, 523, 584.
 HOLIDAYS :—
 In General Post Office, 272, 356, 489.
 For classified officers of Railway Department, 402.
 HOLT, J. J. :—Appointment to the Railway Department, 428.
 HOLT, PRISONER :—Liberation of, 360.
 HOLT-SUTHERLAND ESTATE :—Work of unemployed on, 150.
 HOMEBUSH (See also "RAILWAYS")
 Railway to Waratah, 95, 400.
 Woy Woy platform, railway to Waratah, 407.
 HOMESTEAD LEASES (See "CROWN LANDS")
 HOOPER'S TORPEDO CORPS :—Storage of, 87.
 HORDEEN, MR. ANTHONY :—Typhoid fever at establishment of, 126.
 HORDEEN'S :—Advertising Placards on Tramways, 356.
 HORNSBY (See "RAILWAYS")
 HORSES (See also "TELEGRAPHS")
 Cattle, &c., in Forbes and Molong Districts, 583.
 HOSPITAL (See "SYDNEY HOSPITAL")
 HOUR OF MEETING :—For sittings of Assembly, 207.
 HUDSON BROS. :—Contracts given to, without competition, 69.
 HUNTER RIVER (See "BRIDGES")
 HURSTVILLE :—Passenger traffic at Railway Station, 111.
 HUSBAND, JAMES H. :—Claim of, 155.
 ILLAWARRA (See "RAILWAYS")
 IMMIGRATION :—Mr. G. F. Wise and Mr. F. B. Treatt, 534.
 IMPERIAL INSTITUTE :—Contribution from Australian Colonies, 69.
 IMPORT DUTY (See also "CUSTOMS") :—
 On grapes, New Zealand, 240.
 IMPORTATION OF SPIRITS :—Revenue from, 368.
 IMPROVEMENTS (See "CLARENCE RIVER;" also "CROWN LANDS BILL, No. 2;" also "CIRCULAR QUAY.")
 INDIAN AND COLONIAL EXHIBITION :—Expenditure on, 126.
 INFANTRY (See "MOUNTED INFANTRY")
 INGLIS, THE HONORABLE JAMES :—Sleeping-car for accommodation of, 402.
 INSANE (See "ASYLUMS")
 INSURANCE COMPANIES :—Contribution of, to Fire Brigades Act, 84.
 INTEREST AND INSTALMENTS (See "CROWN LANDS")
 INTOXICATING DRINK INQUIRY COMMISSION :—Second and Final Report, 460.
 INVERELL :—
 Mails to, 7.
 Land Revenue, &c., District of, 15, 122, 344, 363.
 Extension of Railway to, 195, 199.
 Reserve Corps, 307.
 Licensing Board, 371.
 Local Land Board, 376.
 Railway Line to, 557.

Q

QUESTIONS—(continued):—

- IRON:—
 - Testing of, used for Bridges, Roads Department, 62.
 - Do Colonial, 167.
 - Telegraph Poles, 62, 127, 340.
 - Armour Plate for defence works, 141, 205.
 - Supply of ironwork for bridges, 213.
 - Bridges, 432.
- IRON COVE BRIDGE:—
 - Wire netting on side lattice, 21.
 - Return respecting, 424.
 - Protection from Road Traffic, 460.
- ISLAND:—At entrance of Gore's Bay, 578.
- JARDINE SPAR TORPEDO:—Papers respecting, 105, 114.
- JERVIS BAY:—
 - Railway from Kiama, 251.
 - Coaling and Shipping Port, Lighthouse, 324.
- JENOLAN CAVES:—Railway, Tarana to, 56, 167.
- JETTY AT WATSON'S BAY:—Lease of, 564.
- JOADJA:—Mining Reserve, 190, 563.
- JOHNSTON'S BAY:—Old vessels laid up, 207.
- JOHNSTON'S ESTATE:—Street to Railway Station, Peter-sham, 536.
- JUBILEE EXHIBITION (See "EXHIBITION")
- JUNEE:—Court-house, 184.
- JURORS:—District Court, Cooma, 68.
- JURY LIST:—Alteration in System of Summoning, &c., 312.
- JUSTICES OF THE PEACE:—*Supersedeas* to Bankrupt, 319.
- KELSO:—Lock-up, 69.
- KROSENE OIL:—In bonded warehouses, 491.
- KIAMA:—Railway to Jervis Bay, 251.
- KIDMAN, MESSRS.:—Payments to, under contracts, 272.
- KINCHEGA:—Bridge on road to Menindie, 154.
- KINGSBURY H. H. & Co.:—Telegraph material supplied by, 46, 127, 251.
- KOGARAH:—Sans Souci tramway, 56.
- KOONDROOK:—Road to Moulamein, 57, 180, 184, 371.
- KUNNELL:—Land at, Botany Bay, 267.
- LABOUR BOARD:—
 - Particulars of, 33.
 - Expenditure of, &c., 125.
- LAKE ALBERT:—Proposed works at, 618.
- LAND (See also "CROWN LANDS")—
 - Purchase of, in Parramatta, 8.
 - Resumption of, near Bradley's Head, 14.
 - Purchase of, adjoining Dawes Point, 56.
 - Purchase of, Macdonaldtown, 32.
 - Purchase of, on Pennant Hills Road, 491.
 - Resumed for railway and tramway purposes, 74, 265, 271.
 - Sold to Mr. R. Cousins, 184.
 - Resumed, belonging to the Messrs. Ryrie, 217.
 - Kurnell, Botany Bay, 267.
 - Payment of interest and instalments in various districts, 280.
 - For sale, Parish of Molong, 348.
 - Junction of Illawarra and Great Southern Railway, 368.
 - Corner of Oxford and Elizabeth Streets, Paddington, 474.
- LAND BOARDS (See "CROWN LANDS")
- LANDS DEPARTMENT:—
 - Senior Officers in, 13.
 - Overtime Work, 270.
- LANDS OFFICE:—Extension of, 633.
- LANE FAMILY (See "TERALBA COAL-MINING RESERVE")
- LA PEROUSE:—
 - Road near, 412.
 - Aborigines at, 591.
- LAUNCHES:—Employment of Government, 143.
- LAWRENCE:—Court-house, 312.
- LEAVE OF ABSENCE:—
 - Mr. District Court Judge Murray, 69.
 - Mr. O'Malley Clarke, 299, 351.
 - Mr. Yates, 351.
 - Mr. Dalglish, District Surveyor, 352.
- LEESON, MR.:—Telegraph Department, 111, 126.
- LEICHHARDT:—
 - Lock-up, 179.
 - Court of Petty Sessions, 413.
 - Tramway from Darling-street Wharf, Balmain, 543.
- LEONARD, MR.:—Road Contractor, 57.
- LESSEES (See "CROWN LANDS")
- LETTER-CARRIER (See "POSTAL")
- LEWISHAM:—
 - Railway Station, 96, 105.
 - Revenue received at Railway Station, 313.
- LICENSES (See "TIMBER")
- LICENSING ACT:—
 - Introduction of Amending Bill, 21.
 - William Spangenberg's Application for a Billiard License, 38 (2).

QUESTIONS—(continued):—

- LICENSING ACT (continued):—
 - Private Bars in Public Houses, 46.
 - Violations of, 206.
 - Opening public-houses on Christmas Day, 227.
 - Accommodation in City Hotels, 306.
 - Applications for licenses for public-houses, Duxford estate, Glenmore Road, 407.
- LICENSING:—
 - Members of Benches acting as Magistrates, 69, 163.
 - Board:—Inverell, 371.
- LIGHT-HORSE (See "MILITARY")
- LIGHTHOUSE:—Between Broken Bay and Newcastle, 93.
- LIGHTING:—
 - Moama Bridge, 290, 364.
 - Botany Road, 412.
- LISMORE:—
 - Report from Land Board on working of Land Act, 83.
 - Formation of Volunteer Force, 533.
 - Case tried before Police Magistrate, 575.
- LIST (See "JURY LIST")
- LITHGOW:—Cycling on Sundays at, 478.
- LIVERPOOL:—
 - Presbyterian Cemetery, 227, 235.
 - Municipal Council, 319.
 - Duplication of Line from Granville, 331.
- LOANS (See "FINANCE")
- LOCAL LAND BOARDS (See "CROWN LANDS")
- LOCAL OPTION:—Resolution carried in Assembly, 46, 153.
- LOCK-UP:—
 - Moama, 63.
 - Kelso, 69.
 - Leichhardt, 179.
 - Gladesville, 267.
 - Parramatta North, 324.
 - Arncliffe, Rockdale, Kogarah, or Hurstville, 634.
- LOCOMOTIVE (See "RAILWAYS")
- LUCAS, MR. SURVEYOR:—Case of, 522.
- MABEL:—Steam Launch, 275.
- MACARTHUR, MR.:—Late Acting Police Magistrate at Corowa, 180.
- MACDONALDTOWN:—
 - Land purchased at, 32.
 - Revenue received at Railway Station, 313.
- MACKENZIE, MR.:—Examiner of Coal-fields, 7, 14, 20, 33 (2).
- MACLEAN:—
 - Trustees for Recreation Grounds at, 121.
 - Court-house, 312.
- MACQUARIE LIGHTHOUSE:—Electric-lighting, 518, 632.
- MAGISTRATES (See also "STIPENDIARY")
 - Nominations for appointment, 8 (2), 21, 57.
 - Members of Licensing Benches acting as, 69, 163.
 - Young District, 341.
- MAIL CONTRACTS (See "POSTAL")
- MAIL GUARDS:—In mail-vans, 407.
- MAILS (See "POSTAL")
- MAIL TRAIN (See "RAILWAYS")
- MAINTENANCE MEN:—
 - Roads Department, 206.
 - Road, Boree to Parkes, 333.
- MATTLAND:—Registration of dogs in, 191.
- MALOGA:—Reserve at, 364.
- MANGROVE CREEK:—Bridges over, 149.
- MANLY:—
 - Court of Petty Sessions, 88.
 - Aquarium, 533.
- MANNING, MR.:—Coroner at Ryde, 270.
- MAPS:—Missing from the Survey Office, 261.
- MARGIL, MR. W. H.:—Complaint of Mr. Joseph Bolton, 607.
- MARINE BOARD:—
 - Moama, 56, 183.
 - Captain Frederick, 81, 97, 133.
 - Regulations, 414, 597, 632.
 - Suspension of Master Mariner's Certificate, 541.
- MARINE:—Use of cast-iron propellers by steamers, 139.
- "MARIPOSA" s.s. (See "QUARANTINE")
- MARRICKVILLE:—
 - Tramway to Dulwich Hill, 134.
 - Flooding of the Railway Embankment, Cook's River, 179.
 - Billiard Licenses, District of, 270.
 - Drainage of, 633.
- MARTINI-HENRY RIFLES:—Numbers held, issued, and in store, 459, 475, 489.
- MATHESON AND ARNHEIM, MESSRS.:—Tin lease of, Silver-ton, 142.
- McSHARRY v. COMMISSIONER FOR RAILWAYS:—Arbitration Case, 37, 96, 319.
- MEASLES:—And typhoid fever, Alexandria and Waterloo, 111.

QUESTIONS—(continued)—:

- MEAT** :—
Storage of, at Darling Harbour, 75.
Delivery of unwholesome, for consumption, 213.
Government Market, 285.
- MECHANICS' INSTITUTES** :—Endowments, 534.
- MEDALS** :—For Centennial Commissioners, 301.
- MEDICAL** :—Attendance to Employés at Hawkesbury Railway Bridge, 415.
- MEDICAL BILL** :—Introduction of, 39.
- MEDICAL PRACTITIONERS** :—Money due by Government to, 255.
- MELBOURNE EXHIBITION** :—
Commissions, 372.
Appointment of Mr. Oscar Meyer, as Superintendent, 415.
Federal Review of Troops during, 546, 558.
- MEMBERS** (See "PARLIAMENT")
- MENINDIE** :—
Mail Service between Silverton and, 153.
Ferry at, 154.
Bridge on road to Kinchega, 154.
Height above sea level, 163.
- MESSENGERS** (See "TELEGRAPHS")
- METROPOLITAN WATER AND SEWERAGE BOARD** :—
Appointment of Mr. Reginald Bloxsome as Secretary to, 368.
Water Rates charged by, 563, 575.
Applications for position as Secretary to, 423.
- MEYER, MR. OSCAR** :—Appointment, Secretary to Melbourne Exhibition, 415.
- MICHELAGO** :—
Opening of Railway to, 180.
Bench of Magistrates, 613.
- MICROBES** (See "RABBIT PEST")
- MIDELTON, MR.** :—Appointment as Locomotive Engineer, 327, 477, 484.
- MILITARY** (See also "DEFENCES") :—
Examinations for Officers, 57.
Major Parrott's Report, 62.
Storage of Hooper's Torpedo Core, 87.
Armoured Electric Cable, 87.
Jardine Spar Torpedo, 105, 141.
Reserve Corps, 118.
Free Pass to Major Taunton, 121.
Torpedo Corps, 121.
Stores returned from Suakim, 179.
Promotion of Captain H. P. Airey to Brevet-Major, 189.
Defences of the Colony, 289, 367, 402.
Mounted Infantry, 306, 307.
Country Reserve Corps, 307.
Inverell Reserve Corps, 307.
Rifle Clubs, 270, 299.
Supernumeraries—Easter Encampment, 180, 199, 334, 359.
Do Metropolitan and Country Reserves, 318.
Do Payment of the Service, 318.
Orderly Clerks, Brigade Office, 333.
Establishment of Manufactory for Small-arms Ammunition, 414.
Martini-Henry Rifles, 459, 475, 489.
Volunteer Artillery, 541.
Country Cavalry Corps, 497.
Officers' Horses, Servants, and Railway Passes, 521.
Dr. Creed's Speech on Defences of the Colony, 522.
Federal Review of Troops during Melbourne Exhibition, 546, 558.
Brigade Office Accounts, 576.
- MILLGATE v. HON. JOHN SMITH** :—Compliance with Order for Papers, 149, 272.
- MILLS & SHAND** (See "WATER SUPPLY")
- MILPARINKA** :—
Telegraph line to, or Mount Browne, 177.
Public School, 364.
- MINING** (See also "COLLIERIES") :—
Applications for Mineral Leases, 207.
Introduction of Bill, 7.
Gold and Mineral Leases, 14, 105.
Mineral Leases, Captain's Flat, 155, 280, 291, 367.
Business Sites at Captain's Flat, 607.
Department, 21, 33.
Department—Police Magistrates appointed Wardens under, 227, 245.
On Private Property Bill, 33, 377.
Prospecting Vote of £15,000, 34, 189.
Reservations for, Parish of Talbragar, 96.
Diamond Drill in use at Clarence Siding, 102, 190, 207.
Refractory ores, 118.
Messrs. Matheson and Arnheim's tin lease, Silverton, 142.
Joadja Reserve, 190, 563.
Assays made by Department, 276.

Q

QUESTIONS—(continued)—:

- MINING** (continued) :—
On Church and School Lands, 313.
Silver-mining Boom, 341, 371.
Ventilation of Mines, 368.
Shares liable to forfeiture, 372.
Application of Botcher and others for lease at Broken Hill, 377.
Church and School Lands Bill, 377.
Mr. Ridley—South Waratah Coal-mines, 377.
Leases, Cobar District, 458.
Mineral Leases, 471.
Leases held by Messrs. Garrett & Greville, 498.
Teralba Coal-mining Reserve, 498(?), 503, 521, 617.
Boring Operations, Clarence Siding, 498.
Lands held by Mr. Garrett, Minister for Lands, 540, 575, 592.
Permits to Mine for Silver and other Minerals, 564.
Miner's Rights in Districts of Forbes, Parkes, and Molong, 583.
- MINER'S RIGHTS** (See "MINING.")
- MITTAGONG** :—Opening of Regent-street, 529.
- MOAMA** :—
Wharf, 56, 183, 289.
Marine Board, 56, 183.
Lock-up, 63.
Bridge at, 122, 290, 364.
Aborigines at, 122.
Police Buildings at, 143.
Common, 164.
Water Supply, 364.
Commissioner for Affidavits, 367.
- MODEL FARMS** :—Establishment of, 48, 63, 267, 323.
- MOIRA FOREST RESERVE** :—Occupation by Aborigines, 122.
- MOLONG** :—
Traffic on Railway Line, 27.
Volunteer Corps, 280, 337.
Land for Sale at, 348.
Revenue taken at Land Office, 395.
"Pleuro" at Bob's Creek, 414.
Railway Extension to Wilcannia, *via* Parkes, 535.
Railway from Orange, 535, 564, 577.
Post and Telegraph Office, 559.
Railway Goods Traffic, 559.
Railway, 570, 590.
Conditional Purchases taken up in, 577.
Publicans' Licenses, 582.
Deposits, &c., in Savings Bank at, 582.
Horses, Cattle, &c., in District, 582.
Miner's Rights and Business Licenses in District, 583.
Railway Line to Parkes, 583, 617.
Land and Revenue Statistics, 590.
- MONARO** :—Assessment on Runs in, 235.
- MONEY ORDER SYSTEM** :—Amalgamation with Postal and Telegraph, 340.
- MOONEY MOONEY CREEK** :—Snagging of, 262, 324.
- MOORE, MRS.** :—Inquiry into cause of death of, 74.
- MOORE PARK** :—Land taken from Sydney Common, 300.
- MOORE** (See "CROWN LANDS")
- MORIARTY, MR. ALEXANDER** :—Removal of Pay-sheets from Harbours and Rivers Department, 495.
- MORRISSEY, DENIS** :—Conditional Purchases of, Coonabarabran, 189.
- MORTGAGES** (See "CROWN LANDS")
- MOSSMAN'S BAY** :—Reserve fronting, 406.
- MOULAMEIN** :—
Road to Koondrook, 57, 180, 184, 371.
Stock Route, 285.
- MOUNT BROWNE** :—Telegraph line to Milparinka or, 177.
- MOUNT MACQUARIE** :—Road to Carcoar, 34.
- MOUNT MANNING** (See "ROADS")
- MOUNT RENNIE CONVICTS** :—Case of, 28.
- MOUNTED INFANTRY** :—Conversion of Cavalry into, 306.
- MUDGE** :—Railway, Wallerawang to, 79, 395, 535, 564.
- MULLET CREEK** :—Embankments, 533.
- MULTIPLE CABLE** (See "TELEPHONE")
- MULWALA** :—Bridge over Murray River at, 27, 275.
- MUNICIPAL** :—
Roads through Municipalities, 62, 504.
Endowment *pro rata* for contributions from non-resident ratepayers, 173.
Application of Camperdown Council to borrow, 189, 205.
Liverpool Council, 319.
Drainage—Borough of Alexandria, 412.
Number of Municipalities in Colony, 415.
Endowment on Contributions for Municipal purposes, 477.
Rates on Government Property, 473.
Special Grants to, 495, 511.
Revenue, Parkes and Forbes, 559.
Endowment to Municipalities, 570, 634.
Chambers at Forbes and Parkes, 611.
Municipality at Smithfield, 612.

Q

QUESTIONS—(continued)—

- MUNRO DRINKING FOUNTAIN :—Erection of, at Singleton, 448.
- MURGA :—Road to Toogong, 27.
- MURRAY, MR. DISTRICT COURT JUDGE :—Leave of Absence to, 69.
- MURRAY RIVER :—
Control of the Waters of, 28.
Bridge over, at Mulwala, 27, 275.
Bridge over Upper, 34, 275, 301.
Bridge over, at Moama, 122.
Aboriginals, 285.
- MURRUMBURRAH :—Clerk of Petty Sessions at, 436.
- MUSWELLBROOK :—
Abolition of Court of Quarter Sessions at, 218.
Railway to Cassilis, 556, 559.
- NAGLE MICHAEL :—Dismissal of, as Warder, Parramatta Lunatic Asylum, 21.
- NAME OF COLONY :—Cost incidental on proposed change of, 184.
- NAMOI :—Revenue from Electorate, 235, 363.
- NANDI FLAT, CASTLEREAGH RIVER :—Dedication of, 340.
- NANGUS (See "CROWN LANDS")
- NARANDERA :—Bridge at, 518.
- NARBABBI :—
Road to Walgett, 39.
Railway to Walgett, 39, 150.
Railway Station, 163, 227, 284, 340.
Furniture for Court-house, 339.
Racecourse, 352.
- NARRAMINE :—Road to The Bogan, 51, 471.
- NATIONAL PARK :—William Ross, late Overseer, 51.
- NAVAL BRIGADE :—Supply of boats for, 110.
- NAVAL HOME :—Site for, 94.
- NAVIGATION ACT :—Introduction of amending Bill, 21.
- NAVIGATION :—Of Richmond and Tweed Rivers, 291.
- NEILD, MR. J. C., M.P. :—Executive Commissioner, Adelaide Exhibition, 94, 134, 190, 262, 495.
- NEPEAN WATER SUPPLY (See "WATER SUPPLY")
- NET-FISHING :—Hawkesbury River, 262, 314.
- NEWCASTLE (See also "RAILWAYS," also "HARBOURS AND RIVERS DEPARTMENT, NEWCASTLE") :—
Railway and Tramway Employés, 15.
Water Supply, 571.
- NEWINGTON ASYLUM :—
Letter from Ladies of Board of Enquiry, 240.
Letter from Mr. McElhone, M.P., 290.
Management of, 337.
- NEW ZEALAND :—Import duty on grapes, 240, 251.
- NEW SCHOOL, PITT ROW, PARRAMATTA (See "EDUCATION")
- NEW HEBRIDES, THE :—
Monthly Mail Service, 557.
- NEW SOUTH WALES :—
Official History of, 191, 523, 584.
- NORFOLK ISLAND :—
Official connection of Mr. H. T. Wilkinson with, 172.
Visiting Magistrate, 436.
Offer of British Government to hand over to New South Wales, 569.
- NORTH COAST :—(See "RAILWAYS")
- NORTH HEAD :—Removal of Quarantine Station from, 240, 368, 364.
- NORTH SHORE :—
Fares on Tramway, 75.
Whaling Road, 125.
Extension of Railway, 389.
Employees' Cable Tramway, 407.
Railway from Hornsby, 578.
- NORTHERN MAIL :—
Delay of, 293 (?).
Detention of train, 293.
Saturday Train, 408.
- NORTHUMBERLAND :—Visit of Colonial Secretary to, 9.
- NOXIOUS WEEDS :—
Destruction of, 280.
Richmond River District, 533.
- NUISANCE :—
Seaweed, at Botany, 32, 70, 333, 412.
Do Double Bay, 110.
- NYNGAN :—Railway to Cobar, 215.
- OBERON :—Survey of Railway, *vid* Cox's River, 343.
- OCCUPATION LICENSES (See "CROWN LANDS")
- O'DWYER, MRS. (See "CROWN LANDS")
- OFFICERS :—District Engineer's Staff, Bathurst, 271.
- OFFICIAL HISTORY OF NEW SOUTH WALES :—Publication of new edition, 191, 523, 584.
- OPERATORS (See "TELEGRAPHS")
- ORANGE (See also "RAILWAYS") :—
Telegraph Office, 323.
Railway to Molong, 535, 564, 577.

QUESTIONS—(continued)—

- ORDERLY CLERKS (See "MILITARY")
- ORES :—Railway freight on Mineral, 399, 490.
- O'RIEL (See "CROWN LANDS")
- OVER-BRIDGE (See "RAILWAYS")
- OVER-TIME WORK :—In Lands Department, 270.
- OYSTERS :—
Abolition of duty or royalty, 88, 94, 105, 142.
Charge on Spat, 327.
- PACIFIC MAIL STEAMSHIP COMPANY :—
Claim of, respecting San Francisco Mail Contract, 239, 319.
- PADDINGTON :—
Telephone exchange for, 173.
Rifle range, 450, 489.
Land at corner of Oxford and Elizabeth Streets, 474.
- PAIN'S FIREWORKS :—Exclusion of the public from the Domain on occasion of, 213.
- PALMER'S ISLAND :—
Postmaster at, 441.
Stationmaster at, 453.
- PARKS, PUBLIC (See also "CENTENNIAL PARK") :—
Subsidies to, 33.
Electorate of Redfern, 239.
Wee Waa, 272.
Trustees for Pilliga, 339.
Do Richmond, 351.
Do Croydon, 356.
And Recreation reserves—Endowed and handed over to Councils, 384.
- PARIS EXHIBITION :—
Cost to Colony for representation at, 581.
- PARK MR. :—Chief Commissioner of Crown Lands, Hay, 578.
- PARKS :—
Auburn Road Trust, 424.
Arncliffe, 572.
- PARKES (See also "RAILWAYS") :—
Municipal Revenue, 559.
Conditional Purchases taken up in District of, 577.
Public Buildings in, 577.
Publicans Licenses, 582.
Deposits, &c., in Savings Bank, 582.
Public Money spent in, 582.
Miners' Rights and Business Licenses, District of, 583.
Railway Line from Molong, 583, 617.
Municipal Chambers at, 611.
- PARLIAMENT :—
Land resumed in Macquarie-street and Domain for new Houses, 19.
Electric Light in Buildings, 32, 39, 68.
Reporting Staff, 240.
Payment of Members Bill, 256.
- PARLIAMENTARY COMMITTEE ON PUBLIC WORKS :—
Gazetting of, 565.
Appointment of Secretary to, 607.
- PARNELL, THE MISSES (See "CROWN LANDS")
- PARRAMATTA (See also "RAILWAYS") :—
Purchase of Land by the Government, in, 8.
Overbridge at Railway Station, 47.
Purchase of frontage to River by Mr. W. Pritchard, 271.
Deepening the River, 306, 634.
North, Lock-up at, 324.
Asylum, 337, 521.
North, Site for Benevolent Asylum, 343.
Duplication of Railway Line to Penrith, 360, 375 (?), 427, 477, 511.
River Bridge, 424.
Post and Telegraph Master at, 473.
Delay of Mail Train, 612.
Post Office at, 571.
- PARROTT, MAJOR :—Report of, on Military matters, 62.
- PASSES (See "RAILWAYS")
- PASTEUR, MONSIEUR (See "RABBIT PEST")
- PASTORAL (See "CROWN LANDS")
- PASTURES (See "STOCK AND PASTURES BILL")
- PATENT FEES :—Paid to each Attorney-General since Responsible Government, 110.
- PATTERSON (See "CROWN LANDS")
- PAYMENT OF MEMBERS :—
Limiting number of Members, in view of, 33.
Introduction of Bill during Session, 256.
- PAYMENT OF MILITARY SERVICE (See "MILITARY")
- PEARCE'S CORNER (See "RAILWAYS")
- PEAT'S FERRY :—
Railway Accident, 74, 118, 265, 276, 632.
Land resumed at, for Railway purposes, 271.
- PENNANT HILLS' ROAD :—Land purchased by Government on, 491.
- PENNY POSTAL SYSTEM (See "POSTAL")

Q

QUESTIONS—(continued):—

- PENRITH:**—
 Duplication of Line from Granville, 323.
 Duplication of Railway Line from Parramatta, 360, 375 (?), 427, 477, 511.
 Sunday Trains for, 529.
- PERMANENT FREEHOLD LAND AND BUILDING SOCIETY** (See "SYDNEY PERMANENT FREEHOLD LAND AND BUILDING SOCIETY")
- PERSONS EMPLOYED BY SQUATTERS:**—Number of, 313.
- PERTH:**—Telegraphic communication with railway station, 196.
- PETERSHAM:**—
 Railway accident, 190.
 Street between Johnston's Estate and Railway Station, 536.
- "Phylloxera":**—
 Prevention of spread of, 155, 191.
 Board of Inquiry, 490.
 In County of Cumberland, 582.
- PILLIGA:**—
 Post and Telegraph Office, 183.
 Trustees for Park, 339.
 Road from Coonamble, 339.
 Common, 339.
- PITT-STREET SOUTH:**—Wood-paving, 408.
- PLANTING TREES:**—On Forest Reserves, 270.
- PLATFORMS** (See "RAILWAYS")
- "PLEURO":**—Prevalence of, at Bob's Creek, Molong, 414.
- POLES** (See "TELEGRAPHS")
- POLLACK, MR. DAVID:**—Selection of Forfeited Conditional Purchase, Nangus, 318.
- POLICE:**—
 Duties of, under Towns Police Act, 33.
 Interference with Salvation Army, 33.
 Buildings, Moama, 143.
 Quarters, Wellington, 179.
 Do Rylstone, 483.
 Officers in Central Office, 223.
 Suppression of Boxing Matches, 312.
 Barracks, Corowa, 395.
 Sub-Inspector Bell and Detective Tindall, 407, 428.
 Senior Constable Wright, 410.
 Cycling on Sundays.
 Protection of Prisoners in Police Court Cells, 499.
 Stafford, Ex-Sergeant William, 551.
 Lock-up at Arneliffe, Rockdale, Kogarah, or Hurstville, 634.
- POLICE MAGISTRATES:**—
 Mr. Macarthur, late Acting, Corowa, 180.
 Appointed Wardens under Mining Act, 227, 245.
 Parramatta, appointment of, 420.
 Lithgow, 478.
- POLICE OFFICE CELLS** (See "POLICE")
- POLYTECHNIC COLLEGE:**—Establishment of, 584.
- POOL, MR. AND MRS.** (See "CROWN LANDS")
- POONCARIE** (See "EDUCATION")
- POOR OF SYDNEY** (See "CENTENARY OF THE COLONY")
- POSTAL:**—
 Inverell Mails, 7.
 Penny Postage System, 47, 181, 323, 334, 618.
 Post and Telegraph Office, Tumberumba, 57.
 Do. Cobargo, 96.
 Do. Granville, 102.
 Do. Gladesville, 121.
 Do. Pilliga, 183.
 Do. Bourke, 39, 215.
 Do. Broken Hill, 266, 428.
 Do. Stanmore, 276.
 Do. Wollombi, 393.
 Do. Clock for Redfern, 412.
 Do. Bourke, 498.
 Do. Molong and Condobolin, 559.
 Do. Parramatta, 571.
 Mail Service between Menindie and Silverton, 153.
 Transmission of bank pass books, 184.
 Claim of Pacific Steamship Company respecting San Francisco Mail Contract, 239, 319.
 Materials supplied by H. H. Kingsbury and Co., 251.
 Holidays in General Post Office, 272, 356, 489, 556.
 Delay in arrival and delivery of Northern Mails, 293 (?).
 Letter-carrier for Prospect and Sherwood, 301, 388.
 Clerks employed in Secretary's and Mail Branches of the General Post Office, 312.
 Amalgamation of Postal, Money Order, and Telegraph Systems, 340.
 Mail Guards in Mail Vans, 407.
 Redfern Post Office—Supply of Stamps, 413.
 Buildings rented for Post Offices, 424.
 Postmaster at Palmer's Island, 441.
 Post and Telegraph Masters, Parramatta, Grafton, Cootamundra, and Braidwood, 473.

QUESTIONS—(continued):—

- POSTAL** (continued):—
 Monthly Mail Service to New Hebrides, 557.
 Postmaster at Glen Innes, 612.
- POTT'S HILL** (See "WATER SUPPLY")
- POULTON, J. A. H.:**—Case of, 265, 377, 384.
- POWELL, MR., JUN.:**—Appointment and promotion in Customs Department, 143.
- PRICE, MR. W.:**—Appointment of as J.P., 8.
- PRICKLY PEAR:**—Eradication of, 403.
- PRINTING OFFICE** (See "GOVERNMENT PRINTING OFFICE")
- PRISONERS:**—
 In Bourke Gaol, 31.
 Release of, Centenary Celebration, 164.
 Protection of in Police Office Cells, 499.
- PRISON LABOR:**—
 Casino Gaol, 490.
- PRETCHARD, MR. W.:**—Purchase of frontage on Parramatta River, 271.
- PRIVATE BARS:**—In Public Houses, 46.
- PRIVATE PROPERTY:**—Introduction of Bill providing for mining on, 33, 377.
- PRODUCE** (See "FARM PRODUCE;" also "RAILWAYS")
- PROBATIONERS** (See "TELEGRAPHS")
- PROPELLERS:**—Used by steamers, 139.
- PROSECUTIONS BEFORE JURIES:**—Final decision in, 139.
- PROSECUTIONS:**—Under Public Instruction Act, 406, 435.
- PROSPECT:**—
 Letter-carrier for, 301, 388.
 Reservoir, 432, 511, 564.
 Water Supply Works, Messrs. Mills and Shand, 581.
- PROSPECTING VOTE:**—Disposal of £15,000, 84, 189, 327.
- PROTECTION OF PRISONERS** (See "POLICE")
- PROTESTANT HALL, DUBBO:**—Lease of for Lands Office, 584.
- PROVISIONAL SCHOOLS** (See "EDUCATION")
- PRUEN, REGINA v.:**—Depositions, &c., in case of, 8, 79.
- PUBLIC BUILDINGS:**—Forbes and Parkes, 577.
- PUBLIC HOUSES** (See "LICENSING ACT")
- PUBLIC INSTRUCTION ACT** (See "EDUCATION")
- PUBLIC MONEY:**—Spent in Forbes and Parkes, 582.
- PUBLIC OFFICIALS:**—Vouchers for moneys paid by, 251.
- PUBLIC WORKS ACT:**—
 Gazetting of Parliamentary Committee, 565.
 Appointment of Secretary to Parliamentary Committee, 607.
- PUBLIC WORKS DEPARTMENT:**—Recommendations for retrenchment in, 13.
- PUBLIC ACCOUNTS** (See "FINANCE")
- PUBLIC LOANS** (See "FINANCE")
- PUBLICANS LICENSES:**—Districts of Forbes, Parkes, and Molong, 582.
- PUBLIC SCHOOLS** (See "EDUCATION")
- PUBLIC WORKS LOAN ACT OF 1884:**—Amounts borrowed, spent, and balance under, 518, 528.
- PULAMING RUN, GUNNDAH:**—Bates's Selections on, 401.
- PURNAMOOTA:**—Tramway, Silverton to Thackaringa and, 235.
- QUAN:**—Selection of on North arm, Tweed River, 605.
- QUARANTINE:**—Soiled linen landed from s.s. "Mariposa," 301.
- QUARANTINE STATION:**—
 Removal of from North Head, 240, 368, 384.
 Breaking of Quarantine by Officers from, 384.
- QUARTER SESSIONS:**—Bombala, 256.
- QUEANBEYAN:**—Pastoral and Agricultural Show-ground, 56.
- QUEENSLAND BORDER:**—
 Break of Railway Gauge at, 15.
 Railway from Tenterfield to, 15, 183.
 Road from Tumbulgum, 523.
- QUIRINDI** (See "ROADS")
- QUIT RENT:**—
 On Cunninghame's grant, Circular Quay, 184.
 Returns showing, 475.
- QUODLING, MR.:**—Length of service of, 142.
- RABBIT ACT:**—Money due to Messrs. De Saily & Co., 557.
- RABBIT PEST:**—
 Premium for destruction of, 14, 63.
 Inventions for extermination of, 149.
 Fencing between Bourke and Barrigun, 218.
 Commission to inquire into mode of destruction of, 290.
 Subsidy, Balranald, Wentworth, and Bourke, 347.
 Conference for destruction of, 364, 372.
 Introduction of Chicken Cholera, 396.
 Secretary to Commission, 406.
 M. Pasteur's investigations, 460.
 Cost of buildings, Rodd Island, 460.
- RACECOURSES:**—
 Telegraphic Communication between, 332.
 Narrabri, 352.

QUESTIONS—(continued)—

RAILWAYS—

- Department Engineer-in-Chief's, Construction Branch, 214.
- Locomotive engines, 95, 122, 205, 327.
Do manufacture of, in Colony, 6, 47, 110, 144, 413, 405, 495.
Do competitive test of, 47, 69, 122.
- Employés—Newcastle, 15.
Do Drivers and Firemen, 275, 285.
Do Bathurst Workshops, 290, 428.
Do Increase of Wages, 262, 306 (?), 318, 334, 394, 402, 598, 619.
Do and tramways, 441, 540.
Do Existing Lines Branch, 457.
Do services of unregistered Surgeon, 490.
Do Pay to fettle's wives for minding gates, 571.
- Draftsmen dismissed from Office of Engineer-in-Chief, 15
Do Services of Unregistered Surgeon, 490.
- Fares—Peat's Ferry, 271.
Sub-way—Alt-street, Ashfield, 275.
- Illawarra—Loop-line to Wollongong, 276.
Illawarra, 541.
- Hawkesbury River Bridge, 284, 293, 319, 331, 337, 355, 359, 533, 590.
Do do Medical Attendance to Employés, 414.
- Trial Surveys, Engineer for, 291.
- Second-class carriages, 292.
- Sydney to Brisbane, through-tickets, 292.
- Northern Mail trains, 293, 408.
- Cost of carrying grain on Northern, 293.
- Ticket-collector Edward Coole, 293.
- Delays of trains between Sydney and Parramatta, 294.
- Supply of coals for Railway Department, Singleton, 299.
- Differential rates, 300, 313.
- Platforms, Harris Park and Wentworthville, 105.
- Tarana to Jenolan Caves, 56, 167.
- Policy of the Government, 57, 177, 251, 257, 284, 384.
- Refreshment Rooms, 61, 377.
- Trucks, 69.
- Land resumed for, 74.
- Brakes, 74, 388, 632.
- Kiama to Jervis Bay, 251.
- Resumption of land for, 265, 271.
- Platform at Eveleigh, 270.
- Designs for cattle trucks, 63.
- Traffic on Molong lines, 27.
Do at Narrabri Station, 163, 227.
- M'Sharry v. Commissioner, 37, 96, 319.
- Hon. J. Smith v. Commissioner, 51, 80, 96, 102.
- Hon. S. Charles v. Commissioner, 101 (?), 110.
- Narrabri to Walgett, 39, 150.
- Haulage rate on blue metal or gravel from Emu Plains, 47, 68.
- Goods charges, Bourke and Byerock, 195.
- Station, Parramatta, Overbridge at, 47.
Do Bathurst—Hay loading stage, 81.
Do Lewisham, 96, 105.
Do Croydon, 106.
Do Hurstville, 111.
Do Whittingham, 142.
Do Narrabri, 163, 284, 340.
Do Tarago, 368.
Do Blayney, 332.
Do Bathurst, Payment of Wages by Station-master, 394.
Do Eveleigh, 412.
Do Auburn, crossing at, 313.
Do Ashfield, train arrangements, 344.
Do Bowral, 472, 558.
Do Sydney, cloak-room, 545.
Do Albury Water Supply, 584.
Do Rookwood, 607.
Do Strathfield, 582.
- Payment of wages in Department, 20, 81.
- Suspension of Mr. A. Helzinger, 32.
- Fetters, 32.
- Surveyor Nicholas P. Carver, 96.
Alfred Braine, timber inspector, 125.
- And Tramways Time-tables, 15.
- Overbridge, Bathurst, 15.
- Break of Gauge on Queensland Border, 15.
- Tenterfield to Queensland Border (Wallangarra), 15, 183.
- Dubbo to Bourke, 420.
- Earnings and cost of working, 420.
- Appointment of Frederick Cavanaugh and J. J. Holt to Department, 428.
- Mrs. M. Goddard or Baker, 447.
- Trial Survey, Singleton, *via* Jerry's Plains, towards Cassilis, 448.
- Telegraph Probationers connected with, 448.

Q

QUESTIONS—(continued)—

RAILWAYS—(continued)—

- Return Tickets issued in connection with Centennial Exhibition, 448.
- Pastoral holdings on lines of trial surveys, 461.
- St. Leonards to Pearce's Corner (Hornsby), 16.
- Pearce's Corner to Waters of Port Jackson, 84, 97, 402.
- Free Passes—Permanent, 16, 453.
Do to Unemployed, 20.
Do Officials of Department, 68, 411.
Do Major Taunton, 121.
Do Major Staunton, 134.
Do Mr. Clibborn, 385, 401, 440.
Do Wesleyan Ministers, 457.
Do Salvation Army Officer, 461.
- Students at Technical College travelling on, 168.
- Evans's Combination Truck Patent, 27, 32, 34, 39, 63.
- Accident at Peat's Ferry, 74, 118, 265, 276, 632.
Do Petersham, 190.
- Wallerawang to Mudgee, 79, 395.
- Beyond Cassilis, 79.
- Trial Survey, *via* Colo Valley, 80, 266, 319.
- Embankment, Bathurst, 81.
- Goulburn to Crookwell, 88, 450.
Do Cooma, 125.
- Homebush to Waratah, 95.
- Illawarra, 109, 111, 541.
- Sleeping Cars, 118.
- Farm produce received at Darling Harbour, 127, 217.
- Produce Dépôt at Darling Harbour, 102, 140, 191, 240.
- Sheds, Darling Harbour, 144.
- Audit of Accounts, 143.
- Claim of Terry & Co. on Department, 164.
- Communication between officials and passengers on trains while in motion, 172.
- Extension to Circular Quay, 178.
- Bridge over Cook's River, 179.
- Opening to Michelago, 180.
- Extension to Inverell, 195, 199.
- Loop-line near Wollongong, 199.
- Nyngan to Cobar, 215.
- Land belonging to the Messrs. Ryrie resumed for purposes of, 217.
- Officers of District Engineers Staff at Bathurst, 271.
- Suburban Fares, 217.
- Sunday Traffic, 217.
- Officer in charge at Canley Vale Platform 313
- Lewisham, Macdonaldtown, and Stanmore, revenue received at, 313.
- Goulburn to Cooma Junction, Duplication of Line, 317.
- Time-table, delay in issue of, 319.
- Station-master, Eveleigh, 323.
Do Eskbank, 450.
- Granville to Penrith, Duplication of Line, 323.
- Combination Trucks, 327.
- Locomotive Engineers—Mr. Scott and Mr. Midelton, 327, 477, 484.
- Granville to Liverpool, Duplication of Line, 331.
- Bega-Eden, 332.
- Complaints made against employé in Department, 332.
- Trains late in arrival, 334, 372.
- Survey of proposed, to Oberon, *via* Cox's River, 343.
- Special to Windsor, 360.
- Duplication of line between Parramatta and Penrith, 360, 375 (?), 427, 477, 511.
- Through tickets between Sydney and Melbourne, *via* Blayney, 363.
- Land at junction of Illawarra and Great Southern Railways, 368.
- Passenger traffic on Great Northern and North-Western, 372.
- Limited express, engaged compartments, 376.
- Rates of workmen's tools of trade, 376.
- Suburban, System of, 385.
- North Shore, Extension of, 389.
- Rates on merchandise for Glen Innes, Emmaville, &c., 394.
- Orange to Molong, Bathurst to Bourke, and Mudgee Line, 395, 535, 564, 577.
- Molong, 570, 590.
- Molong to Parkes, 583, 617.
- Molong to Wilcannia, *via* Parkes, 535.
- Loans, 396.
- Rates on cut wood, ores, &c., 399.
- Freight on Empty Sacks, Mineral Ores, &c., 490.
- Fares and freight on Homebush to Waratah Line, 400.
- Engaged compartments in railway carriages, 401, 439, 449, 458 (?), 495, 570.
- Sleeping-car for accommodation of the Honorable Messrs. Abigail and Inglis, 402.
- Public holidays for classified officers, 402.
- Woy Woy Platform, Homebush and Waratah Railway, 407.
- Smoking on platforms, 407.

QUESTIONS—(continued):—

RAILWAYS—(continued):—

- Engine-sheds and Changing-places, Dubbo and Welling-
ton, 503.
- Charges for Carriage of Wheat, 504.
- Redfern into the City, 512.
- Buradoo Platform, 518.
- Line to Forbes, 521, 611.
- Resumption of Mr. John Black's Property on Homebush-
Waratah Line, 523.
- Audit Branch, Newcastle, 523.
- To Wilcannia, 527 (*), 536; 540, 571.
- Sunday Train for Penrith, 529.
- Mullet Creek Embankments, 533.
- North Coast, 534.
- Orange to Molong, 577.
- Mr. C. Colls, 536.
- Board of Commissioners, 536, 557.
- Trial Surveys, Parkes to Condobolin, 545.
- Cartage of Wool, Produce, &c., from Darling Harbour,
546.
- Muswellbrook to Cassilis, 556, 559.
- Line to Inverell, 557.
- Goods Traffic, Molong, Borenore, and Cowra Stations, 559.
- Charges for demurrage and storage, 564.
- Locomotive Department, removal of Timekeepers, 572.
- Tunnel at Redfern, 576.
- Line to Codobolin, 576, 605, 617.
- Hornsby to North Shore, 578.
- Silver ore carried on, 581.
- Express Goods Train, 584.
- Via Borenore, 597.
- Return on capital, &c., 605.
- Fares of ladies accompanying Mr. W. J. Allen, M.L.A.,
to Bourke, 612.
- Delay of Mail Train between Granville and Parramatta,
612.
- Workshops at Bathurst, 618.

RANDWICK:—

- Rifle Range, 450, 489.
- Discontinuance of Tolls, on road, 106.

RATES (See "WHARVES")

RATIONS:—For unemployed, National Park, 106.

READ, MR.:—Government Meat Market, 285, 333.

REAL PROPERTY ACT:—Assurance Fund, 179, 207, 261,
305, 341, 459.

RECEIPT STAMPS:—For money paid on Public Service, 331.

RECLAMATION WORK:—Cook's River, 262.

RECREATION RESERVES (See "RESERVES")

RECRUIT MONEY (See "VOLUNTEERS")

REDFERN:—

- Public Parks, Electorate of, 239.
- Sewerage of, 412.
- Clock for Post and Telegraph Office, 412.
- Supply of stamps at Post Office, 413.
- Court-house, 413.
- Tram for Western Mail Train, 343, 534.
- Railway into City from, 512.
- Railway Tunnel at, 576.

REFORMATORY:—

- Establishment of, for Boys, 28, 331.
- Rookwood, 612.

REFRACTORY ORES:—Treatment of, 118.

REFRESHMENT ROOMS (See "RAILWAYS")

REFUNDS (See "CROWN LANDS")

REGENT-STREET:—

- Wood-paving of, 412.
- Mittagong, opening of, 529.

REGISTRAR-GENERAL'S DEPARTMENT:—Office Hours and
Leave of Absence, 63.

REGISTRARS OF BIRTHS:—Fees to District, 411.

REGULATIONS:—

- For admission to the Bar, 8.
- Respecting Cattle sent from New South Wales to
Victoria, 180.
- Marine Board, 414.

RELIEF:—To the Poor of Sydney, 291.

RELIEF WORKS (See "UNEMPLOYED" also "CHINESE")

RELIGION:—State aid to, 143.

RENTS (See "CROWN LANDS" also "QUIT RENTS")

REPORTING STAFF:—Parliamentary, 240.

RESERVES (See also "MILITARY," see also "FORESTS" also
"VOLUNTEERS") :—

- Rushcutter's Bay, 13.
- Village, Captain's Flat, 47, 279.
- Parish of Dunoon, 83.
- Recreation, Adaminaby, 96.
- Do Cooma, 96.
- Do Maclean and Brushgrove, 121.
- Bulga Stock Road, Jerry's Plains to Homebush, 139, 163,
251.
- Travelling stock, on Eugowra and Canowindra, 179.

Q

QUESTIONS—(continued):—

RESERVES—(continued):—

- Joadja Mining, 190, 563.
- Belmore, near Canowindra, 292.
- Made in 1886 and 1887, 284.
- Terania Forest, 307, 458.
- Eastern and Central Districts, 307.
- Maloga, 364.
- Recreation, and parks endowed and handed over to
Councils, 384.
- Fronting Mossman's Bay, 406.
- Galathera and Boggy Creek Tanks, 415.
- Timber, 535.
- Taralba Coal-mining, 498, (2) 503, 521.
- Bondi, Occupation of by Aquarium Company, 553.

RESERVOIR:—

- High-level at Pott's Hill, 356.
- Prospect, 432, 511.

RESUMED AREA (See "CROWN LANDS")

RESUMPTION OF LAND:—

- For Railway Purposes, 265, 271.
 - High School, Elizabeth-street, Public School, Castlereagh-
street, 424.
 - Near Bradley's Head, 14.
 - Macquarie-street and the Domain, 19.
 - Robertson's Point, Cremorne, 153.
- REVENUE AND EXPENDITURE (See "FINANCE")
- REVENUES (See also "CROWN LANDS," also "ELECT-
ORAL") :—
- Of Great Powers of Europe, America, and Australasian
Colonies, 109.

RICHARDSON, MAJOR-GENERAL:—Report on Rifle Clubs,
299.

RICHMOND:—

- Common, 214.
- Park, 351.

RICHMOND, THE:—

- Roads and Bridges in Electorate, 21.
- Land Court, 83.
- Tug for, 93.
- Tug Service, 164.
- Conditional Purchases, in District, 126, 207.
- Improvement to entrance of River, 276, 498.
- Navigation of River, 291.
- Boats for River, 292.
- Snagging operation on, 399.
- Sir John Cooke's report on River entrance, 458.
- Noxious Weeds, 533.

RIDLEY, MR.:—

- Bravery in South Waratah Coal-mine, 377.
- RIDLEY, Mr. G. S.:—Employment of, as Crown Lands
Agent, 522.

RIFLE CLUBS:—

- Establishment of, 270.
- Report of General Richardson, 299.

RIFLE RANGE:—Paddington and Randwick, 450, 489.

RINGBARKING:—

- Effect of, on health and climate, 180, 262.
- Number of acres on which permission granted for, 290.

RINKS SKATING:—

- Construction and Licensing of, 552.

ROADS:—

- Clerks in Department, 168.
- Distribution of Additional Vote of £100,000, 7.
- And Bridges, Electorate of the Richmond, 21.
- Toogong to Murga, 27.
- Mount Macquarie to Carcoar, 34.
- Narrabri to Walgett, 39.
- Payment of Contractors, 39.
- Narramine to the Bogan, 51, 471.
- Moulamein to Koondrook, 57, 180, 184.
- Forbes and Eugowra, 57.
- Mr. Leonard, Road Contractor, 57.
- Department—Iron for Bridges, 62.
- Passing through Municipalities—Vote for, 62, 504.
- Between Cudal and Davy's Plains Run, 81, 280.
- Mr. E. Cannell, contract near Stone-quarry Creek
Crossing, 105.
- Randwick, 106.
- Whaling, East St. Leonards, 125.
- Through E. K. Crace's Estate, Gungahleen, 139, 140, 436.
- Mr. White's purchase of, near Timor and Isis River, 142.
- Menindie to Kinchega, 154.
- Through Australian Agricultural Company's land,
Warrab, 167.
- Belar Creek, Parish of Deringullen, 168, 340.
- Wanaaring to Tibooburra, 177.
- Byrock to Gongolgan, 183, 279.
- Maintenance Men, 206.
- Gunnedah to Barraba, 266, 289.
- Near Mr. Fergusson's Selection, Belabula, 272.
- St. Alban's to Mount Manning, 284.

Q

QUESTIONS—(continued):—

- ROADS—(continued):—
 Maintenance men on, Boree to Parkes, 333.
 Coonamble to Pilliga, 339.
 Compensation to Joseph Gersbeck, Parish of Canoblas, 348.
 Near La Perouse, 412.
 Auburn Park Trust, 424.
 Contracts—Mr. Wells, Engineer, 449.
 Woods-lane, near Quirindi, Yarraman Reserve, 472.
 Botany, 474.
 Turnbulgum to Queensland Border, 523.
 Grants for, 534.
 Vote for Country, 633.
- ROBERTS, MR. H. R.:—Promotion of, in Central Police Office, 223.
- ROCK FLAT:—Public School, 437.
- RODD ISLAND:—Cost of Buildings for M. Pasteur's investigations, 460.
- ROOKWOOD:—
 Church of England Chaplain at Cemetery, 141.
 Reformatory, 612.
 Railway Station, 607.
- ROLLS:—(See "ELECTORAL")
- ROSS, WILLIAM:—Late Overseer at National Park, 51.
- ROYAL NAVAL HOME:—Site for, 94.
- ROYALTY:—On Oysters, 83, 94, 105, 142.
- RUNS (See also "CROWN LANDS")
- RUSHCUTTER'S BAY:—Reserve, 13.
- RUSSELL'S WHARF:—Resumption of, by the Government, 8.
- RYDE:—Mr. Manning, Coroner at, 270.
- RYLSTONE:—Police Quarters, 483.
- RYRIE, MESSRS.:—Land belonging to, resumed for Railway purposes, 217.
- SACKS, EMPTY:—Railway freights on, 490.
- SALARIES (See "CIVIL SERVICE")
- SALVATION ARMY:—Interference with, by Police, 33.
- SAMOA:—Action of the Germans in, 20.
- SAN FRANCISCO MAIL CONTRACT:—Claim of Pacific Mail Steamship Company, 239.
- SAVINGS BANKS:—
 Deposits, &c., in, at Forbes, Parkes, and Molong, 582.
- SCHOOL ATTENDANCE OFFICERS (See "EDUCATION")
- SCHOOLS OF ARTS:—
 Site for, Wee Waa, 239, 299.
 Supply of *Hansard* and *Government Gazette* to, 245.
 Endowments, 534.
- SCOTT, MR.:—Police Magistrate, Deniliquin, 173.
- SCOTT, MR.:—Locomotive Engineer, 327, 477.
- SEA-WALL:—Coogee Bay, 106.
- SEAWEED:—
 Nuisance of, at Botany, 32, 70, 333, 412.
 Do Double Bay, 110.
- SEED POTATOES:—Supplied to persons in Clarence Electorate, 171.
- SELFE, MR. NORMAN:—Improvements at Circular Quay, 388.
- SEWERAGE (See also "METROPOLITAN WATER AND SEWERAGE BOARD")
 Eastern Suburbs, 16, 164.
 Blasting in connection with works, 118.
 Board for control of Bondi Scheme, 126.
 Bondi Sewer, 154.
 Western Suburbs, 267 (?) 546, 558.
 Redfern, 412.
- SHARES:—Liable to forfeiture, 372.
- SHELLHARBOUR:—
 Dredge for, 195.
 Wharf at, 209.
- SHERIFF'S OFFICERS:—
 Recovery of Fees due to, 83.
 Bailiff's mileage charges, 209.
- SHERIDAN, MR. PHILIP:—Trustee of Association Cricket Ground, 447, 518.
- SHERWOOD:—Letter-carrier for, 301, 388.
- SHOALHAVEN:—Entrance to River, 572.
- SHOW-GROUND, WALGETT, 352.
- SIBLEY, DR. J. C.:—Health Officer, Watson's Bay, 448.
- SICKNESS:—In Public Schools, 214.
- SILVER-MINING:—"Boom" in connection with, 341, 371.
- SILVER ORE:—Carried by Railway, 581.
- SILVERTON:—
 Mail service between Menindie and, 153.
 Tramway to Thackaringa and Purnamoota, 235.
 Court-house, 372.
- SINGLETON:—
 Court of Quarter Sessions at, 213.
 Railway trial survey, *via* Jerry's Plains, towards Cassilis, 448.
 Erection of Munro Drinking Fountain, 448.
- SITE FOR VILLAGE:—Parish of Heyden, county of Wellesley, 536.
- SKATING RINKS:—Construction and Licensing of, 552.

QUESTIONS—(continued):—

- SKENE, WILLIAM:—Prelease of, at Conargo, 143.
- SLEEPING CARS:—
 Cost of Railway, 118.
 For accommodation of The Honorable Messrs. Abigail and Inglis, 402.
- SLY, DR.:—Employment of, by Government, 101 (?), 110.
- SMALL ARMS AMMUNITION:—Establishment of Manufactory, 414.
- SMITH, THE HON. J. (See also "CROWN LANDS"):—
 Arbitration Case *v.* Commissioner for Railways, 51, 80, 96, 102.
- SMITH, MR. T. R.:—Alleged appointment of, under Government, 142, 214.
- SMITFIELD:—Municipality of, 612.
- SMOKING:—On Railway Platforms, 407.
- SNAGGING:—
 Mooney Mooney Creek, 324.
 Operations, Richmond River, 399.
- SOCIETIES (See "AGRICULTURAL")
- SOILED LINEN (See "QUARANTINE")
- SOUDAN CONTINGENT:—Stores returned from Suakim, 179.
- SOUTH WARATAH COAL-MINE:—Bravery of Mr. Ridley in, 377.
- SPANGENBERG, WILLIAM:—Application of, for a Billiard License, 38 (?).
- SPAT (See "OYSTERS")
- SPECIAL GRANTS:—To Municipalities, 495, 511.
- SPECIAL TRAINS (See "RAILWAYS")
- SPIRITS:—
 Duties paid on, 31.
 Importation of, 368.
- SPIT:—Bridge over Middle Harbour at, 27.
- SQUATTERS:—Persons employed by, 313.
- ST. ALBANS (See also "ROADS"):—
 Court-house, 178.
- STAFFORD WILLIAM, EX-SERGEANT:—Dismissal of from Police, 557.
- STAMP OFFICE:—Mr. Foskett, 214, 299.
- STAMPS (See also "RECEIPT STAMPS")
 Supply of to Redfern Post Office, 413.
- STANMORE:—
 Post and Telegraph Office, 276.
 Revenue received at Railway Station, 313.
- STATE AID TO RELIGION:—Final abolition of, 143.
- STATE HOUSE:—
 Competition in designs for, 155.
 Plans, specifications, and tenders, 319.
 Authority for expenditure under, 355.
 Erection of, 383.
- STATION-MASTER (See "RAILWAYS")
- STATISTICAL REGISTER:—Handbook to, 75.
- STATISTICS:—Crown Lands, 461.
- STATUARY:—Purchase of, by the Government, 227, 592.
- STAUNTON, MAJOR:—Free pass issued to, 134.
- STEAMERS:—Use of cast-iron propellers by, 139.
- STEAM-LAUNCHES:—Employment of Government, 143.
- STEAM LAUNCH:—Mabel, 275.
- STEPHEN *v.* ERWIN:—Decree, 332, 511.
- STIPENDIARY MAGISTRATES:—
 Complaints against Mr. Addison, 167.
 Do other, 215.
 Number of cases dealt with by Mr. Addison at one sitting, 173.
 And Deputies, 190.
 Mr. Deputy Delohery, 331.
- ST. LEONARDS:—
 Railway from Pearce's Corner (Hornsby), 16.
 Railway from Pearce's Corner to Waters of Port Jackson, 84, 97.
 Whaling Road, 125.
- STOCK:—
 Watering places for travelling, 19.
 Sale of diseased cattle, 20.
 Disease in, District of Bourke, 81.
 Road, Jerry's Plains to Homebush, 139, 163.
 Diseases in, 262.
 Route, Moulamein, 285.
 Reserves for travelling, 179.
 Regulations respecting, passing from New South Wales to Victoria, 180.
 Route, Moulamein to Koondrook, 180, 371.
- STOCK ACT:—Consolidation of, 272.
- STOCK AND PASTURES BILL:—Consideration of, 428.
- STORAGE:—Charge for, 564.
- STORES, MILITARY:—Returned from Suakim, 179.
- STRATHFIELD:—Railway Station, 582.
- STRAY CATTLE:—In country towns, 33.
- STREET:—
 Formation of, North of General Post Office, 396.
 Johnson's estate and Petersham railway station, 536.

Q

QUESTIONS (*continued*):—

- SUAKIM:—Military Stores returned from, 179.
 SUBPENAS:—Charge for, 110.
 SUBSIDY (See "RABBIT-PEST")
 SUBURBS:—
 Sewerage of Eastern, 16.
 Sewerage of Western, 267 (?), 546, 553.
 Drainage of Western, 546.
 Railway Fares to, 217.
 Water Supply, 597, 601.
 SUBURBAN RAILWAYS (See "RAILWAYS")
 SUB-WAY (See "RAILWAYS")
 SUNDAY:—Railway and Tramway Traffic, 217.
 SUPERANNUATION FUND (See "CIVIL SERVICE")
 SUPERINTENDENT OF TELEGRAPHS:—Leave of absence, 340.
Supersedeas (See "ADMINISTRATION OF JUSTICE")
 SUPREME COURT APPEALS ACT:—Cases decided under, 117.
 SURGEON, UNREGISTERED:—Services to Railway employes, 490.
 SURVEY OFFICES (See "CROWN LANDS")
 SUTHERLAND, MISS:—Public School, Cooma, 436.
 SWEEPS:—Betting and "Consultations," 218.
 SYDNEY:—
 Public Expenditure in, and Country Districts, 7.
 Water Supply, 597.
 SYDNEY COMMON:—Land taken from, 300.
 SYDNEY HOSPITAL:—Case of John Halloran, 257.
 SYDNEY (See "RAILWAYS")
 SYDNEY PERMANENT FREEHOLD LAND AND BUILDING SOCIETY:—Chairman of, 441.
 SYPHON:—Tender for laying of, in George-street West, 606.
 TALBRAGAR:—Reservations for Mining purposes, 96.
 TANKS (See also "RESERVES"):—
 In Eastern and Western Districts, 461.
 TARAGO:—Railway Station, 368.
 TARBAN CREEK:—Bridge over, 313.
 TARANA:—Railway to Jenolan Caves, 56, 167.
 TEACHERS (See "EDUCATION")
 TECHNICAL COLLEGE:—Students travelling on Trams or Railways, 168.
 TECHNICAL EDUCATION (See "EDUCATION")
 TELEGRAPHS (See also "POSTAL"):—
 Department—Mr. Leeson, 111, 126.
 Iron Poles, 62, 127, 340.
 Operators, 45.
 Purchase of Wire, 45, 67, 80.
 Brush Carbons, 46.
 Materials supplied by H. H. Kingsbury & Co., 46, 127, 251.
 Line to Milparinka or Mount Browne (Tibooburra), 177.
 Sixpenny telegrams, 181.
 Communication with Perth Railway Station, 196.
 Stations using quadruplex instruments, 206.
 Office at Gladesville, 267.
 Horses purchased by Department, 271, 301, 383, 459, 512.
 The "Gulcher" Electric Machine, 74, 106, 272, 305, 373.
 Office at Stanmore, 276.
 Messengers, 300.
 Office, Orange, 323.
 Communication between various Racecourses, 332.
 Amalgamation with Money Order and Postal Systems, 340.
 Superintendent of, 340.
 Employment and dismissal of line repairers, 387.
 Condemned poles, 387.
 And Post-office, Wollombi, 393.
 Do. Stanmore, 276.
 Do. Bourke, 39, 215, 498.
 Do. Redfern, Public Clock for, 412.
 Do. Molong and Condobolin, 559.
 Department, 405, 431, 453, 474, 490, 540, 583, 589, 591, 634.
 Buildings rented as Telegraph Offices, 424.
 Office, Broken Hill, 428.
 Probationers connected with Railways, 448.
 Station-master, Palmero Island, 453.
 Masters at Parramatta, Grafton, Cootamundra, and Braidwood, 473.
 Line from Tumbulgum to Tweed River, 477.
 Increases to employes, 529.
 Bourke to Wanaaring, 541.
 Cable Communication with Europe, 583.
 TELEPHONE:—
 Exchange for Paddington, 173.
 Frieze in George-street for telephonic system, 7, 265.
 George-street Tunnel for system, 46, 68.
 Cable for Frieze, 46, 127, 265, 453, 490.
 Multiple-cable purchased by Telegraph Department, 266.
 TEMPE:—Flooding of district by Railway embankment, 179.
 TENTERFIELD (See also "RAILWAYS")
 Railway to Queensland Border (Wallangarra) 15, 183.
 TERALBA COAL MINING RESERVE:—
 Mineral Conditional Purchases on, 498 (?) 503, 521, 617.

QUESTIONS (*continued*):—

- TERRY & Co.:—Claim of, on Railway Department, 164.
 TERANIA:—Forest Reserve, 307, 458.
 THACKARINGA:—Tramway from Silverton to, 235.
 THEATRES:—Dangerous condition of, 533.
 THEFTS:—Of Workmen's Tools, 134, 265, 276.
 THOMAS, MR.:—Formerly inmate of Gladesville Asylum, 402, 473.
 THOMAS, MR. WILLIAM, J.P.:—Appointment as Justice of the Peace, 541.
 THOMSON, MR.:—Chief Inspector of Accounts, 153.
 THROUGH TICKETS:—
 Railway, Sydney to Brisbane, 292.
 Sydney to Melbourne, *via* Blayney, 363.
 TIBOOBURRA:—
 Public School for, 177.
 Telegraph line, Milparinka or Mount Browne, 177.
 Road from Wanaaring, 177.
 TIMBER:—
 Destruction of, on Burrawong Run, 52.
 Licenses, 327.
 Reserves, 535.
 TIMBER DUTIES (See "CUSTOMS")
 TIME-TABLES:—
 Printing of Railway and Tramway, 15.
 Delay in issue of Railway, 319.
 In Chinese language, 333.
 TINDALL, DETECTIVE (See "POLICE")
 TOOGONG:—Road, to Murga, 27.
 TORPEDO:—
 Storage of Hooper's Core, 87.
 Armoured Electric Cable, 87.
 Jardine Spar, 105, 141.
 Pay of Corps, 121.
 Cables, 373.
 TRAFFIC (See "RAILWAYS")
 TRAINS (See "RAILWAYS")
 TRAINING SCHOOL:—Education Department, 484.
 TRAINING INSTITUTION (See "EDUCATION")
 TRAINING SHIP (See "VERNON")
 TRAMWAYS:—
 Employes Newcastle, 15, 540.
 Do Drivers and Firemen, 275, 295.
 Time-tables, 15.
 Electric Motors for, 56.
 Kogarah-Sans Souci, 56.
 Ashfield and Druitt Town, 57.
 Free Passes to Officials of Department, 68.
 Land resumed for, 74.
 North Shore, 75.
 Advertising on, 97, 356.
 Bridge-street to Railway Station, 109.
 Belmore Park Crossings, 110.
 Marrickville to Dulwich Hill, 134, 633.
 First-class car, Sydney to Woollahra, 135.
 Watering Routes, 165.
 Students at Technical College travelling on, 168.
 Extensions, 195.
 Sunday traffic, 217.
 Silverton to Thackaringa and Purnamoota, 235.
 Field of Mars, 240, 266, 343, 598.
 Time-tables in Chinese language, 333.
 Tram to meet Western mail train at Redfern, 343, 534.
 Proposals to work with compressed air, 396.
 North Shore cable employes, 407.
 Construction of cars, 413.
 Botany Road line, 413.
 And Railway Employes, 441, 540.
 Guards, 450, 545.
 Total miles and cost of, 498.
 Darling-street Wharf, Balmain, to Leichhardt, 543.
 Construction, 633.
 TRANSIT COMMISSION:—
 Employes, License Fees, Revenue and Expenditure, 383.
 Solicitor, 447.
 Inspector-General of Police, seat on Board, 457, 551.
 Mayor of Sydney, seat on Board, 551.
 TRAVELLING STOCK:—Reserves, 179.
 TREASURER'S ADVANCE ACCOUNT (See "FINANCE")
 TREASURY, THE:—Assistant Examiner of Accounts, applications for position of, 473.
 TREATT, MR. F. B.:—Chief Clerk, Immigration Department, 534.
 TRIAL SURVEYS (See "RAILWAYS")
 TROLLOPE, MR. F. G. A.:—Tumut and Gundagai Land Boards, 406.
 TRUST FUNDS:—Under control of Government, 396, 400.
 TRUSTEES (See "ASSOCIATION CRICKET GROUND")
 TUG:—
 For Richmond River, 93.
 Service, Richmond River, 164.

Q

QUESTIONS (continued):—

- TUMBERUMBA :—Post and Telegraph Office, 57.
- TUMBULGUM :—
 - Telegraph Line to Tweed River, 477.
 - Road to Queensland Border, 523.
- TUNNEL UNDER GEORGE-STREET (See "TELEPHONE")
- TURON RIVER :—Bridge over, at Wallaby Rock, 48.
- TWEED, THE :—
 - Dredge for River, 276, 575.
 - Navigation of River, 291.
 - Telegraph Line from Tumbulgum to Heads, 477.
- TYPHOID FEVER :—
 - Measles and, in Alexandria and Waterloo, 111.
 - At Mr. Anthony Hordern's establishment, 126.
 - M. Pasteur's Investigations, 460.
- ULMARRA :—Light Horse, 363.
- UNEMPLOYED :—
 - Free Railway Passes to, 20.
 - Labour Bureau, 33.
 - Casino Municipal Council, 75.
 - Rations for, National Park, 106, 283.
 - Casual Labour Board, 125.
 - Work on Holt-Sutherland Estate by, 150.
 - Particulars respecting, 172.
 - Engineers, fitters, ironmoulders, and blacksmiths, on relief works, 253, 300.
- UNIVERSITY OF SYDNEY :—
 - Examination Fees, 347.
 - Department of Engineering, 497.
- UNWHOLESOME MEAT :—Delivery of, for consumption, 213.
- VENTILATION OF MINES :—Appointment of Board, 338.
- "VERNON," THE :—
 - Training Ship—Prisoners in Gaols, 420.
 - Numbers of officials, duties, and leave granted, 312.
 - Boys absconded from, 318.
- VESSELS :—Laid up in Johnston's Bay, 207.
- VETERINARY SCHOOL :—Erection of, in connection with University, 395.
- VICTORIA :—
 - Regulations respecting Cattle sent from New South Wales to, 180.
 - Prohibition of importation of Grapes into, 256.
- VILLAGE :—Site for, parish of Heyden, county of Wellesley, 536.
- VILLAGE RESERVE :—Captain's Flat, 47.
- VINEYARDS :—
 - Phylloxera in, 155.
 - Board of Inquiry into Phylloxera, 490.
- VOLUNTEERS :—
 - Molong Corps, 280, 337.
 - Recruit money due to, 301.
 - Easter Encampment, 318, 334, 337, 359.
 - Ulmarra Light Horse, 363.
 - Martini-Henry Rifles, 459, 475, 489.
 - Capitation Allowance, Reserve Corps, 471.
 - Rifle Range, Paddington and Randwick, 450, 489.
 - Country Cavalry Corps, 497.
 - Formation of Force, Lismore, 533.
 - Artillery, 541.
- VOUCHERS :—Furnished by Public Officials for moneys paid, 251.
- WAGGA WAGGA :—Local Land Board and Survey Office, 28, 261.
- WALGETT :—
 - Road from Narrabri, 39.
 - Railway from Narrabri, 39, 150.
 - Show Ground, 352.
- WALLABADAH COMMON :—Dedication of, 337.
- WALLANGARRA :—Railway, Tenterfield to, 183.
- WANAARING :—
 - Road from to Tibooburrah, 177.
 - Bore for water, 292.
 - Telegraph from Bourke, 541.
- WARATAH :—Railway, Homebush to, 95, 400.
- WARDENS UNDER MINING ACT :—Police Magistrates appointed as, 227, 245.
- WAREHOUSES, BONDED :—Kerosene Oil, &c., in, 491.
- WABIALDA (See "CROWN LANDS")
- WARRAH :—Road through the A. A. Company's land, 167.
- WATERING-PLACES :—For travelling stock, 19.
- WATERLOO :—Measles and Typhoid Fever in Alexandria and, 111.
- WATER RATES (See "METROPOLITAN WATER AND SEWERAGE BOARD")
- WATER SUPPLY :—
 - Nepean—Control of, 32, 126.
 - Do Expenditure on, 154.
 - Byrock, 38.
 - Conservation of, in Country, 61.
 - Carrying out proposals of Royal Commission, 172.
 - Euriowie, 80.
 - Brass fittings for Country Towns, 218.

QUESTIONS (continued):—

- WATER SUPPLY—(continued):—
 - Water Reservoir near Cobar, 284.
 - Wanaaring Bore for, 292.
 - Construction of High-level Reservoir at Pott's Hill, 356.
 - Moama, 364.
 - Germanton, 395.
 - Prospect Reservoir, 432, 511.
 - Newcastle, 571.
 - Prospect Works, Messrs. Mills & Shand, 581.
 - Railway Station, Albury, 584.
 - Sydney and Suburbs, 597.
 - Certain Suburbs, 601.
- WATER AND SEWERAGE BOARD (See "METROPOLITAN WATER AND SEWERAGE BOARD")
- WATSON'S BAY :—
 - Jetty at, 564.
- WAVERLEY :—
 - Foreshores of, and Bondi, 134.
 - Church of England Chaplain at Cemetery, 141.
 - Gateways to Centennial Park, 478.
- WELLINGTON :—
 - Police Quarters at, 179.
 - Engine-sheds and changing place at, 503.
- WENTWORTH (See also "CROWN LANDS"; also "RABBIT PEST") :—
 - Customs Duties collected at, 38.
- WENTWORTHVILLE :—Railway platform, 105.
- WEE WAA :—
 - Site for School of Arts, 239, 299.
 - Public Park for, 272.
- WEEDS (See "NOXIOUS WEEDS")
- WELLS, MR. :—Tenders for Road Contracts, 449.
- WESLEYAN MINISTERS :—Free Passes to, 457.
- WESTERN MAIL TRAINS :—Tram to meet, 343, 534.
- WESTERN SUBURBS :—
 - Sewerage of, 267 (2), 546, 558.
 - Drainage of, 546, 634.
 - Burglaries in, 618.
- WHALING ROAD :—Opening of, 125.
- WHARVES :—
 - Shellbarbour, 209.
 - Moama, 289.
 - Public Botany, 411.
 - Rebate of Rates on Public, 535.
 - Erection of, at Bourke, 598.
- WHEAT :—Charge for carriage of, 504.
- WHITE, MR. FREDERICK :—Purchase of Roads near Timor and Isis River by, 142.
- WHITE, THE MESSRS. :—Runs held in Upper Hunter Electorate, 591.
- WHITTINGHAM :—Railway Station, 142.
- WILCANNIA :—
 - Customs Duties collected at, 38.
 - Bridge over the Darling at, 311, 528.
 - Athenæum at, 364.
 - Railway Line to, 527 (4), 536, 540, 571.
 - Court House at, 577 (2).
 - Railway Extension from Molong, via Parkes, 535.
- WILKINSON, MR. H. T. :—Official connection of, with Norfolk Island, 172.
- WILKINSON'S AUSTRALIAN MAGISTRATE :—Supply of, 45.
- WINDSOR (See "RAILWAYS")
- WINES :—Duties paid on, 31.
- WIRE (See "TELEGRAPHS")
- WISE, MR. G. F. :—Immigration Agent, 534.
- WOOD :—Differential Railway rates on carriage of, 313.
- WOODS-LANE (See "ROADS")
- WOOD-PAVING :—
 - Circular Quay, 301.
 - Pitt-street South, 408.
 - Regent-street, 412.
- WOLLOMBI :—Post and Telegraph Office, 393.
- WOLLONGONG (See also "RAILWAYS") :—
 - Railway loop-line near, 199.
- WOOLLAHRA :—First-class tram car running to, 135.
- WOOL :—Cartage of, from Darling Harbour, 546.
- WORKMEN (See also "RAILWAYS") :—
 - Theft of Tools of, 134, 265, 276.
 - Railway rates on tools of trade, 376.
 - Prospect Reservoir, 511, 564.
- WOY WOY PLATFORM (See "RAILWAYS")
- WRIGHT, SENIOR-CONSTABLE :—Case of, 440.
- WYONG CREEK (See "BRIDGES")
- YARRALUMLA :—Conditional Purchases, 154.
- YARRAMAN RESERVE :—Woods-lane, near Quirindi Road, 472.
- YATES, MR. LEOPOLD :—
 - Position of, in Civil Service, 180.
 - Leave of absence, 351.
- YEOMANS, MRS. :—Inquiry into cause of death, 74.
- YOUNG :—Magistrates, 341.

REFERENCES TO THE VOTES AND PROCEEDINGS, VOL. I—13TH PARLIAMENT—SESSION, 1887-8.	PAPERS.	
	VOL.	PAGE.
Q		
QUIT RENTS :—		
Return to Order (<i>Session 1887</i>) laid on Table, 559	5	195
QUORUM (See "NO QUORUM")		
R		
RABBIT NUISANCE ACT AMENDMENT BILL :—		
Motion made (<i>Mr. Abigail</i>) for leave to bring in, presented and read 1 ^o , 200; motion made for 2 ^o and Debate adjourned, 225; Order of the Day discharged, and Bill withdrawn, 241.		
RABBIT PEST :—		
Return to Order (<i>Second Session, 1887</i>), laid on Table, 150	8	973
Motion made (<i>Mr. Wall</i>) for a return showing miles of wire netting now erected by the Government for the prevention of rabbits, with all costs incident thereto, 191; Return to Order laid on Table, 223	8	979
Motion made (<i>Mr. J. P. Abbott</i>) for reports of Mr. Stanley, on disease introduced by Drs. Butcher and Ellis, 287.		
DESTRUCTION OF RABBITS BY MEANS OF DISEASES :—		
Report of Health Board and other papers on proposals for, laid on Table, 335	8	955
RABBIT PEST SUPPRESSION BILL :—		
Motion made (<i>Mr. Garrett</i>) for Committee of the Whole, 263; Message from Governor, 263; House in Committee, Resolution reported and agreed to, 309, presented and read 1 ^o 317.	8	981
RAILWAYS (See also "GOVERNMENT RAILWAYS BILL"; also "NORTH SHORE, MANLY, AND PITWATER TRAMWAY AND RAILWAY BILL"; also "OAKLEY PARK COAL-MINING COMPANY'S RAILWAY BILL"; also "REDHEAD COAL-MINE RAILWAY ACT AMENDMENT BILL"; also "GOVERNMENT RAILWAYS ACT AMENDMENT BILL"; also "YOUNG WALLSEND COAL COMPANY'S RAILWAY BILL") :—		
ACCIDENT AT PETERSHAM BRIDGE :—		
Motion made (<i>Mr. McElhone</i>) for all correspondence, reports, &c, in reference to, 48.		
Report by Mr. Wm. Cruickshank, M.I.C.E., relative to, laid on Table, 103	6	617
ACCIDENT, PEAT'S FERRY :—		
Motion made (<i>Mr. Schey</i>) for all reports, evidence, recommendations, and all attainable information relating to, 128; Return to Order laid on Table, 635	6	467
ALLEGED FRAUDS :—		
Return to Order (<i>Second Session, 1887</i>) laid on Table, 122	6	631
AND TRAMWAYS OF NEW SOUTH WALES :—		
Report for 1886, laid on Table, 6	6	1
Do for 1887, laid on Table, 635	6	225
APPOINTMENTS MADE IN THE DEPARTMENT :—		
Motion made (<i>Mr. Lyne</i>) for a Return showing permanent and temporary, since 1st January, 1887, 40; Return to Order, laid on Table, 231	2	97
BOWRAL STATION :—		
Motion made (<i>Mr. M'Court</i>) for papers in reference to the improvement of, 506; Return to Order laid on Table, 578. (Not printed.)		
BOWRAL OR MOSS VALE TO ROBERTSON :—		
Motion made (<i>Mr. M'Court</i>) for papers in reference to construction of, 519.		
BLUE METAL FOR TRAMWAYS AND :—		
Motion made (<i>Mr. O'Sullivan</i>) for all tenders, minutes, and papers relating to purchase of 3,000 tons, 48; Return to Order, laid on Table, 122	6	1109
BYROCK TO BREWARRINA :—		
Motion made (<i>Mr. Waddell</i>) for construction of light line, and by leave withdrawn 370.		
CARRIAGE OF WOOL AND OTHER PRODUCE :—		
Original tenders for, from the Railway Station, Redfern, and Darling Harbour, laid on Table (<i>as Exhibits only</i>), 454.		
CLAIM OF MRS. BUTTERLEY :—		
Motion made (<i>Mr. Schey</i>) for a Select Committee, and Return to Order (<i>Second Session, 1887</i>) referred, 12; Report brought up, 140	6	647
COBAR :—		
Return to Order (<i>Second Session, 1887</i>), laid on Table, 5	6	997
COLO VALLEY RAILWAY SURVEY :—		
Motion made (<i>Mr. Frank Farnell</i>) for papers, 303; Returns (<i>in part</i>) to Order, laid on Table, 348, 352	6	1047, 1067
COMBINATION TRUCKS :—		
Return respecting service of, in use from 1st January to 30th June, 1886, laid on Table, 6	6	617
Further correspondence respecting Evans patent, laid on Table, 49, 71	6	937, 945
Motion made (<i>Mr. Lyne</i>), that this House do now adjourn to consider the payment of £16,000 by the Government for the Evans patent, and by leave withdrawn, 53.		
Correspondence respecting, designed by Messrs. Wilkinson, Perry, Anderson, and Brazenor and Valentine, laid on Table, 88	6	919
Motion made (<i>Mr. Hassall</i>) for a Select Committee to inquire into, 130; correspondence laid on Table, referred, 151, 302; authorized to make visits of inspection, 155; Report brought up, 626	6	815
Petitions from persons interested praying to be heard in person or by Counsel before the Select Committee, presented, 144, 150	6	913, 915
Further correspondence respecting Wilkinson's and the Evans' trucks, laid on Table, referred to Select Committee on "Combination Trucks," 302	6	953
Further correspondence respecting Wilkinson's patent, laid on Table, 360; referred to Select Committee, 389	6	933
CONSTRUCTION :—		
Motion made (<i>Mr. O'Sullivan</i>) that, like roads, should be constructed more with a view to settle the country and give cheap access to markets than for commercial profit, that light railways should be preferred to roads, that interest on the money borrowed be provided for by a graduated tax on the land enhanced in value by such railways, and withdrawn, 232.		
CONTINUOUS BRAKE :—		
Return respecting, laid on Table, 635	6	959
COOMA TO BOMBALA :—		
Motion made (<i>Mr. Dawson</i>) for all papers and correspondence connected with the trial survey of the extension, 76; Return to Order laid on Table, 277	6	1041
CROSSING TO CONNECT EASTGROVE WITH GOULBURN :—		
Motion made (<i>Mr. Teece</i>) for papers, 386; Return to Order laid on Table, 454	6	907

REFERENCES TO THE VOTES AND PROCEEDINGS, VOL. I—13TH PARLIAMENT—SESSION, 1887-8.	PAPERS.	
	VOL.	PAGE.
R		
RAILWAYS—(continued) :—		
DIFFERENTIAL RATES :—		
Motion made (<i>Mr. Lyne</i>) for all papers, correspondence, &c., in reference to the origin and continuation of, 103.		
EDDY, MR. E. M. G. :—		
Correspondence respecting the appointment of, as Chairman of Railway Board, laid on Table, 537.	6	625
EMPLOYEES :—		
Information respecting the Officers in the Department of Public Works and Permanent-way men, laid on Table, 28	8	1053
EXTENSION TO BROKEN HILL, SILVERTON, AND THE BARRIER RANGES :—		
Motion made (<i>Mr. Garland</i>) that any railway policy submitted to Parliament should include, and withdrawn, 273.		
FREE PASSES :—		
Return respecting, laid on Table, 519	6	721
FREE PASSES TO SCHOOL CHILDREN :—		
Motion made (<i>Mr. Abbott</i>) for all minutes, and other documents, written or sent by any Minister, or officer in their Departments, or by the Commissioner, in reference to the resolution authorizing the free carriage of children who were attending schools, 40; Return to Order, laid on Table, 231	6	711
FREE PASSES TO JUDGES OF LIVE STOCK :—		
Motion made (<i>Mr. Wall</i>) for Committee of the Whole to consider expediency of issuing, journeying to and from Pastoral and Agricultural Shows, and negatived, 59.		
FREE PASSES TO EX-MEMBERS OF THE LEGISLATIVE ASSEMBLY :—		
Motion made (<i>Mr. Haynes</i>) that the Resolution affirming that members returned to three Parliaments, on ceasing to be members, shall be entitled to a permanent free pass,—be rescinded, and debate adjourned, 129; Order of the Day postponed, 433; Order of the Day discharged 506.		
FREE PASSES ISSUED BY THE MILITARY STAFF OFFICE TO VOLUNTEERS :—		
Return respecting, during the quarter ended 30 June, 1888, laid on Table, 524	6	723
FREIGHT OF CONTRACTORS PLANT AND MATERIAL :—		
Return showing, paid to Department by various Contractors during years 1883 to 1886 respectively, laid on Table, 28	6	747
GRANVILLE TO PENRITH :—		
Information respecting Duplication of Line, laid on Table, 360	6	1023
GOULBURN TO THE COOMA LINE JUNCTION :—		
Motion made (<i>Mr. O'Sullivan</i>) for papers in connection with duplication of 314: Return to Order laid on Table, 559	6	979
GREAT NORTHERN AND NORTH-WESTERN RAILWAYS :—		
Return respecting passenger traffic on, laid on Table, 339	6	733
HARDEN STATION :—		
Motion made (<i>Mr. Gordon</i>) for return showing goods and passenger traffic, revenue, and expenditure at, 294; Return to Order, laid on Table, 338	6	741
HOMEBUSH TO WARATAH :—		
Return respecting the construction of, laid on Table, 191	6	1021
Return respecting fares and freights, laid on Table, 512	6	743
INVERELL :—		
Petitions in favour of route from Guyra <i>via</i> Wandsworth and Tingha, presented, 84, 529	6	1033, 1035
IRON AND STEEL RAILWAY AND TRAMWAY MATERIALS :—		
Motion made (<i>Mr. Fletcher</i>) for particulars of purchase of, 479.		
ISAAC WEBBELL, GATEKEEPER, RAILWAY DEPARTMENT :—		
Information respecting compensation to family of, laid on Table, 403	6	645
LAND RESUMED FOR, AND TRAMWAY PURPOSES :—		
Motion made (<i>Mr. Schevy</i>) for return showing amount of compensation paid annually for, during the last seven years, giving particulars, 103; Return to Order laid on Table, 267	6	1115
LAND RESUMED FOR, AT BEXLEY :—		
Motion made (<i>Mr. Hurley</i>) for a Select Committee to inquire into and report upon, 233.		
LIMITED EXPRESS TRAIN :—		
Information respecting compartments engaged in, from 1st November, 1887, to 1st April, 1888, laid on Table, 385	6	727
LOCOMOTIVE ENGINES :—		
Motion made (<i>Mr. Lyne</i>) for all papers, correspondence, and reports, in connection with the late tests of the "Vulcan" and "Mogul," 4C.		
Motion made (<i>Mr. Fletcher</i>) for all tenders and correspondence relating thereto, for manufacture of, required by the Government, 41.		
Motion made (<i>Mr. Wall</i>) for a return showing the number employed during twelve months ending 1st September, 1887, conveying trains between Mount Victoria and Penrith; also the number used in conveying same trains between Penrith and Sydney, 58; Return to Order, laid on Table, 81	6	807
Papers relative to Tenders for, and Tests for suitable Type of, laid on Table, 71	6	757
Further correspondence respecting Tests for suitable Type of Engines, laid on Table, 88	6	805
Motion made (<i>Mr. Fletcher</i>) for a return showing the cost of "Heavy Consolidated," "Mogul," and "Vulcan," in running order, and of the class which the Government have decided to adopt, including all charges, 103; Return to Order, laid on Table, 496	6	811
Motion made (<i>Mr. Copeland</i>) for correspondence, &c., in connection with calling for tenders and recent letting of contracts for, in the Colony, 479.		
Return respecting manufacture of, in Colony, laid on Table, 496	6	809
MR. L. C. JENKINS, LATE DRIVER :—		
Correspondence respecting, laid on Table, 505. (Not printed.)		
MURRUMBURRAH PLATFORM :—		
Motion made (<i>Mr. Gordon</i>) for return showing goods and passenger traffic, revenue, and expenditure at, 295; Return to Order, laid on Table, 338	6	739
MUSWELLBROOK-CASSILIS RAILWAY LINE :—		
Motion made (<i>Mr. Fitzgerald</i>) for plans and papers connected with, 519.		
NARRABRI TO WALGETT :—		
Motion made (<i>Mr. Dangar</i>) for copy of final survey of route, with plan and reports, showing distance, characteristics of country, cost, &c., 41; Return to Order laid on Table, 174	6	993
Motion made (<i>Mr. Dangar</i>) for cheap line of Railway, and by leave withdrawn, 369.		
NARRABRI STATION :—		
Return of Traffic to and from, from 1st January to 31st October, 1887, laid on Table, 231	6	737
Return of Traffic to and from, for 1886 and 1887, showing increase for 1887, laid on Table, 338	6	735

REFERENCES TO THE VOTES AND PROCEEDINGS, VOL. I—13TH PARLIAMENT—SESSION, 1887-8.	PAPERS.	
	VOL.	PAGE.
R		
RAILWAYS—(continued) :—		
NARRABRI TO MOREE :—		
Motion made (<i>Mr. Hassall</i>) that any scheme of railway proposals should include the already proposed line, and withdrawn, 238.		
OCCUPATION OF COMPARTMENTS by Ms.L.A.—		
Motion made (<i>Mr. McElhone</i>) for adjournment of the House in reference to, 378.		
O'ROURKE AND MCSHARRY v. THE COMMISSIONER :—		
Paper in connection with the case, laid on Table, 5).....	6	699
Motion made (<i>Mr. Lyne</i>) for all papers, correspondence, &c., including arbitrators award (exclusive of evidence) in the case of, 130.		
ORANGE TO MOLONG, BATHURST TO BOURKE, AND THE MUDGEE LINE :—		
Motion made (<i>Dr. Ross</i>) for return of the expenditure at, and the number of passengers to and from the various stations, the amount received at each, and the number of men employed, 258 ; Return to Order laid on Table, 603.....	6	755
OSBIC-STREET, GUNNEDAH :—		
Motion made (<i>Mr. Goodwin</i>) for all correspondence, reports, plans, &c., respecting flooding of, by a railway drain, 22 ; Return to Order laid on Table, 122	6	1077
RAILWAY POLICY OF THE GOVERNMENT :—		
Ministerial statement made by Sir Henry Parkes on, 501, 641.		
Adjournment moved (<i>Mr. Moore</i>) for the purpose of discussing, 513.		
RAILWAY LABOURERS ON BLAYNEY AND COWRA LINE :—		
Motion made (<i>Mr. Jeanneret</i>) for adjournment of the House to bring under notice the condition of, and matters of urgent public importance in connection therewith, 325.		
REBATES ALLOWED BY DEPARTMENT :—		
Return of, during years 1883-4-5-6, laid on Table, 22.....	6	751
REFRESHMENT-ROOMS :—		
Return to Order (<i>Session, 1835-6</i>) laid on Table, 403	6	653
REMOVAL OF ENGINE-SHEDS FROM DUBBO TO WELLINGTON :—		
Motion made (<i>Mr. Kelly</i>) for Select Committee to inquire into and report upon, 233.		
RESUMPTION OF EDWARD IRBY'S LAND AT BLUFF RIVER :—		
Motion made (<i>Mr. Lee</i>) for a Select Committee to inquire into all circumstances attending, on the extension from Glen Innes to Tenterfield, 147 ; Return to Order (<i>Second Session, 1887</i>) referred to Select Committee, 424 ; Mr. Thompson's name discharged from Select Committee, 432.		
Petition from Edward Irby to be represented before Select Committee, presented and prayer granted, 476.	6	813
SILVER ORE :—		
Return respecting, carried on, laid on Table, 635	6	749
SLEEPING BERTH—NASH v. COPELAND :—		
Return to Order (<i>Second Session, 1887</i>) laid on Table, 122	6	701
STATIONS BETWEEN SYDNEY AND HURSTVILLE :—		
Return of passenger traffic at each station, to and from, for six months ended 30th September, 1887, laid on Table, 165	6	729
ST. LEONARDS TO PEARCE'S CORNER :—		
Motion made (<i>Mr. Trickett</i>) for all claims, letters, &c., in reference to any claims for compensation in respect of any lands or improvements thereon, on the line, with official reports or valuations, 168.		
ST. PETER'S—LIVERPOOL :—		
Petition praying early construction of, presented, 59, 76.	6	1029, 1031
SUBURBAN TRAFFIC :—		
Return showing for four Sundays, of November, 1887, laid on Table, 311	6	731
SUPPLY OF COAL ON GREAT NORTHERN :—		
Motion made (<i>Mr. McElhone</i>) for papers, &c., in reference to contracts of Messrs Reid and Longworth, and offer of Mr. Nowland at lower price, 352 ; Return to Order, laid on Table, 505 ...	6	673
SYDNEY TO FORBES, VIA MOLONG, BORENORE TO FORBES, COMBING TO FORBES, WOODSTOCK TO FORBES, AND COWRA TO FORBES :—		
Return respecting, laid on Table, 524.....	8	1027
THE CASE OF DANIEL CORKERY :—		
Motion made (<i>Mr. Lyne</i>) for all reports, papers, &c., in connection with the suspension, dismissal, and reinstatement of, as Locomotive Engineer in Department, 147 ; Return to Order laid on Table, 302	6	633
THROUGH TICKETS—SYDNEY TO BRISBANE :—		
Information respecting, laid on Table, 302	6	725
TICKET COLLECTOR EDWARD COOLE :—		
Information respecting, laid on Table, 302	6	643
TRAFFIC INSPECTORS ROBERTS AND CRAWFORD :—		
Motion made (<i>Mr. Lyne</i>) for all papers, applications, &c., in reference to salary and house allowance to, 241 ; Return to Order laid on Table, 277	6	627
WAGGA WAGGA TO TUMBERUMBA AND THE UPPER MURRAY :—		
Motion made (<i>Mr. Lyne</i>) that any scheme of railway proposals should include a line from, and withdrawn, 238.		
WHITTINGHAM PLATFORM :—		
Motion made (<i>Mr. Gould</i>) for all correspondence, petitions, &c., in reference to additional accommodation at, 155 : Return to Order laid on Table, 252.....	6	1093
WORKSHOPS AND SHEDS AT BATHURST :—		
Motion made (<i>Mr. Cortis</i>) for adjournment of the House to consider removal of men from, and answers given by Minister in the House, 328.		
YOUNG TO DUBBO :—		
Petition certain inhabitants of Grenfell in favour of, presented, 476.	6	1037
Do do Parkes do 476.	6	1037
Do do town and district of Young in favour of, presented and read by Clerk, 496.	6	1039
REAL PROPERTY ACT :—		
EXAMINERS OF TITLES UNDER :—		
Motion made (<i>Mr. J. P. Abbott</i>) for a return showing work dealt with by Mr. Burton and the other Examiners, 70 ; Return to Order laid on Table, 112.....	2	1017
Annual Returns under, for 1887, 578.....	8	1261
REBATES (See "RAILWAYS").		
RECLAMATION OF NEUTRAL BAY AND CAREENING COVE :—		
Petition of Residents and Ratepayers on the North Shore, presented, 273.	3	893

REFERENCES TO THE VOTES AND PROCEEDINGS, VOL. I—13TH PARLIAMENT—SESSION, 1887-8.		PAPERS.	
	VOL.	PAGE.	
R			
RECOMMITTAL OF BILLS :—			
Passed, 98, 152, 201, 373, 507, 548, 586.			
Negatived, 507, 586, 595.			
RECORDS OF HOUSE :—			
Retention of, from the custody of the Clerk, reported by Mr. Speaker, 51; motion of <i>privilege</i> moved in reference to, records returned, and motion withdrawn, 53.			
Entry expunged from Votes and Proceedings, 90.			
RECREATION RESERVES (See also "RESERVES") :—			
Return showing subsidies from the year 1880 to 1887 inclusive laid on Table, 524	5	807	
DIXON'S BAY, BONDI :—			
Return respecting occupation of, by the Bondi Aquarium Company, laid on Table, 553.....	5	799	
REDFERN AND DARLING HARBOUR STATIONS (See "RAILWAYS").			
REDHEAD COAL-MINE RAILWAY ACT AMENDMENT BILL :—			
Petition presented (<i>Mr. Day</i>) for leave to bring in, 228; leave given, presented, and read 1 ^o , 231; referred to Select Committee, 236; Report brought up, 277; read 2 ^o , committed, reported, report adopted, 321; read 3 ^o , passed, and sent to Council, 325; returned with amendments, 390; Amendments agreed to, 463; Message to Council, 464; assent reported, 492.	2	1071	
REFORMATORY FOR BOYS :—			
Motion made (<i>Mr. Foster</i>) that the establishment of, is a matter of urgent necessity, 89.			
REFRESHMENT COMMITTEE :—			
Sessional Order passed, 11.			
Name added to, 89.			
Report in reference to removal of notices exhibited in refreshment room, brought up, 505.			
REFRESHMENT-ROOMS (See "RAILWAYS").			
REGAN DANIEL (See "CROWN LANDS").			
REGINA v. CHRISTENSON (See "ADMINISTRATION OF JUSTICE").			
REGINA v. PRUEN (See "ADMINISTRATION OF JUSTICE").			
REGISTERED MEDICAL PRACTITIONERS' BILL :—			
Motion made (<i>Mr. Cortis</i>) for Committee of the Whole, 88; House in Committee, and Resolution agreed to, 107; presented and read 1 ^o , 108; motion made for 2 ^o , and objection taken that Order of Leave is exceeded sustained, and Bill withdrawn, 192.			
REGISTERED MEDICAL PRACTITIONERS BILL (No. 2) :—			
Motion made (<i>Mr. Cortis</i>) for Committee of the Whole, 219: Order of the Day postponed, 252; Motion made for House to go into Committee, and House counted out, 321; Order of the Day restored, 404; motion for 2 ^o negatived, 508.			
REGISTRAR-GENERAL (See "CIVIL SERVICE").			
REGISTRATIONS OF INVENTIONS :—			
Letters of, for 1883, laid on Table, 191, 420	{ 9	1	
	10	1	
REGULATIONS :—			
LAI D ON TABLE :—			
Amendment of Timber State Forest and Quarry, 360	5	595	
Beer Duty Act, 35	3	883	
Commons Acts of 1873 and 1886, 6.....	5	825	
Crown Lands Act of 1884, 40, 155, 267, 429	5	581, 583, 591, 597	
Do do Further amendment of Schedule of Classes of Fencing, 40, 199, 613 ..	5	585, 587, 589	
Do do Notification of cancellation, 360.....	5	595	
Do do Amendment to No. 111, 302	5	593	
Customs Regulation Act of 1879 and Customs Duties Act of 1887, 208.....	3	865	
Electric Telegraph Act, 35, 608	4	1161, 1165	
Fire Brigades Act, 6, 578, 634	2	611, 613, 617	
Imported Stock Acts, 6 (?), 524	8	637, 639, 641	
Industrial School for Girls, Parramatta, 155	4	521	
Public Instruction Act, 6 (?).	4	517, 519	
Volunteer Force Regulation Act, 6, 257	2	37, 39	
Diseases in Sheep and Imported Stock Acts, 257	8	651	
Patents' Office, 257, 378	8	1241, 1245	
Bankruptcy Act of 1887, 451	2	731	
Mining Act Further Amendment Act of 1884, Mining Leases, 492	8	539	
REID AND LONGWORTH (See "RAILWAYS").			
REID, WILLIAM JAMES (See "CROWN LANDS BILL No. 2").			
RELIEF TO POOR OF SYDNEY :—			
Information respecting, during Centennial Week, 302.....	8	1031	
RELIGION (See "STATISTICS").			
RELIGIOUS PURPOSES (See "CROWN LANDS").			
REMOVAL OF TIMBER FROM CROWN LANDS NEAR CLARENCETOWN :—			
Motion made (<i>Mr. Creer</i>) for Papers, 335: Return to Order laid on Table, 385.....	5	499	
RENHAM, MICHAEL CHARLES (See "CROWN LANDS").			
RENTS (See "CROWN LANDS"; also "DISTRESS FOR RENT ABOLITION BILL"; also "PREFERENTIAL CLAIMS FOR RENT BILL").			
REPAYMENT OF LOANS BILL :—			
Ordered (<i>Mr. Burns</i>), founded on Resolution of Ways and Means No. 12, presented and read 1 ^o , 628; read 2 ^o ; committed, reported, report adopted, read 3 ^o ; passed, 639; sent to Council, 640; returned without amendment, 642; assented to in Council Chamber, 642.			
REPLY, RIGHT OF (See "STANDING ORDERS").			
REPORTS :—			
LAI D ON TABLE :—			
Auditor-General's, on Receipts and Expenditure for 1886, 2	3	509	
Do do do for 1887, 563	3	657	
Railways and Tramways of New South Wales for 1886, 6	6	1	
Do do do for 1887, 635	6	225	
Intoxicating Drink Inquiry Commission, with Minutes of Evidence and Appendices (First Part), 6	7	1	
Stock Branch Department of Mines for 1886, 6.....	8	543	
Stock and Brands Branch, Department of Mines, for the year 1887, 408	8	573	
Thirty-second Annual, of Postmaster-General, being for 1886, 6	4	783	
Postmaster-General, Thirty-third Annual, being for 1887, 635	4	881	
Technical Education, by Edward Combes, C.M.G., 28	4	229	
Public Charities for 1886, 52.....	4	691	
Changes in Penal Administration of the Colony, 52	4	1213	
Government Asylums Inquiry Board—Reports, &c., from Manager, Matrons, Superintendents, and others, on, 82	4	617	
Forest Branch, Department of Mines, 97	5	765	

REFERENCES TO THE VOTES AND PROCEEDINGS, VOL. I—13TH PARLIAMENT—SESSION, 1887-8.		PAPERS.	
		VOL.	PAGE.
R			
REPORTS—(continued) :—			
LAI'D ON TABLE (continued) :—			
Railway Accident to Express Goods Train at Petersham Bridge, by Wm. Cruickshank, M.I.C.E., 103.	6	617	
City of Sydney Improvement Board for 1886-7, 112	2	269	
Theatres and other Public Places of Amusement, 128	8	1209	
Board on Competitive Designs for State House, 196	8	1279	
Major-General Schaw on Defences of New South Wales, 199	2	47	
Fisheries of the Colony by the Commissioners, to 31st December, 1886, 223	8	1069	
Police Department for 1887, 257	4	1203	
Creation, Inscription, and Issue of Stock, under Inscribed Stock Act of 1883, 257	3	505	
Department of Lands for 1880, 257	5	1	
Mr. G. H. Stayton, M. Inst. C.E., on Sewerage and Drainage of the Western Suburbs, 267; plan to be appended, 613	5	895	
Examiner of Coal-fields in connection with charges made against him in Legislative Assembly, 273	8	217	
Sydney Grammar School, for 1886, 285	4	573	
Do do 1887, 432	4	581	
Nautical School Ship Vernon, 1887, 285	4	683	
Goulburn Fire Brigade Board, 1887, 302	2	609	
Extension of Channel, and Improvements to Wharf at Moama, 302	3	1039	
Superintendent of Drills on the Boring Operations on the 101½-mile, Bourke to Wanaaring Road, 302	8	953	
Sir John Coode's, on Lake Macquarie Harbour Works, 324	3	895	
Do Entrance to Richmond River, 462	3	905	
Do Entrance to Clarence River, 475	3	899	
Board of Health on Proposals to effect Destruction of Rabbits by means of Diseases, 335	8	955	
Do Typhoid Fever at Coast Hospital, 608	2	235	
Typhoid Fever in Sydney and Suburbs, from 1876 to 1888, 543	2	231	
Immigration Agent, for 1887, 352	2	159	
Metropolitan Fire Brigades Board, for 1887, under the Fire Brigades Act of 1884, 378	2	571	
Trustees of the Sydney Free Public Library, for 1887-8, 378	4	581	
Annual of the Department of Mines, for 1887, 378	8	1	
Minister of Public Instruction on Education, for 1887, laid on Table, 408; Annex XVII to, 425	4	1	
Annual, on Prisons for 1887, 420	4	1223	
Annual, on Military Forces of the Colony for 1887, 425	2	1	
Inspector-General of the Insane for 1887, 429	4	635	
Deniliquin Fire Brigades Board for 1887-8, 462	2	605	
Annual, of the Civil Service Board for 1887, 475	2	69	
Annual, Board for the Protection of the Aborigines, 475	4	687	
Fatal Accident to John Mansfield at the Northumberland Colliery, 475	8	249	
Fatal Accident to Edward M'Carran at the West Wallsend Colliery, 475	8	259	
Coast Hospital, Little Bay, for 1887, 479	4	599	
Vaccination, for 1887, 479	2	229	
University of Sydney for 1887, 524	4	547	
Prospect Dam, Messrs. Bishop, Whitton, and Bennett, C.E.s, 529	5	849	
Board appointed to inquire into Kenny Hill and Pott's Hill Reservoir Scheme, 547	5	853	
President of the New South Wales Commission on the Adelaide Jubilee International Exhibition, 1887, 565	8	985	
State Children's Relief Department, for year ended 5th April, 1888, 565	4	753	
STANDING ORDERS COMMITTEE :—			
Proposed new, 476	1	845	
FROM ELECTIONS AND QUALIFICATIONS COMMITTEE :—			
Seat of the Honorable Bernhard Ringrose Wise, Esquire, South Sydney, 55	1	903	
Election Petition—Hellmrich v. W. J. Allen, Paddington, 296	1	891	
REFRESHMENT COMMITTEE :—			
Removal of Notices, 505	1	887	
FROM SELECT COMMITTEES :—			
Pharmaceutical Society of New South Wales Incorporation Bill, 76	2	1061	
Church and Perkins Streets (Newcastle) Bill, 76	2	891	
North Shore, Manly, and Pittwater Tramway and Railway Bill, 89	2	1011	
Yass Roman Catholic Church Land Sale Bill, 99	2	1215	
Claim of Mrs. Butterley, 140	6	647	
Leichhardt Council Chambers (Mortgage) Bill, 145	2	957	
Broken Hill Tramway Bill, 200, 302	2	825	
Thomas Thompson's conditional purchase, made at Moama, 200	5	207	
Victorian Coal-mining Company's Extension Bill, 201	2	1201	
Grafton School of Arts Trustees Enabling Bill, 224	2	919	
Christian Chapel Lands Sale Bill, 224	2	883	
Claims of Captain Rossi, 263	2	143	
Redhead Coal-mine Railway Act Amending Bill, 277	2	1071	
Purchase by the Government of Land adjoining the Australasian Steam Navigation Company's Wharf, 305	3	917	
St. Saviour's, Glebe, Land Leasing Bill, 314	2	1079	
Robert Mackrell's Conditional Purchase at Forbes, 342	5	285	
Parramatta Municipal Quarries Bill, 343	2	1055	
Parramatta, Church-street, Amended Alignment Bill, 348	2	1049	
Silverton Tramway Act Amending Bill, 348	2	1089	
Sydney Hydraulic Power Company's Bill, 349	2	1129	
Oakey Park Coal-mining Company's Railway Bill, 353	2	1029	
Oakey Park Coal-mining Company's Railway Bill (Second), 519	2	1037	
Kiama Tramway Act Amendment Bill, 369	2	951	
Liverpool Church of England Grammar School Land Sale Bill, 409	2	965	
Petition of George Matcham Pitt, junior, 416	5	485	
Hunter-street, Newcastle, Extension Bill, 429	2	925	
Broken Hill and Suburban Gas Company's Bill, 429	2	817	
Sydney and Suburban Electric Lighting Bill, 454	2	1099	
North Shore Boroughs Wharves Bill, 463	2	971	
Crown Lands Purchases Validation Bill, 468	5	509	
Parry's Conditional Purchases on Currugundi and Warren South Runs, 487	5	239	
Mrs. Ann Rouse's Conditional Purchase at Kahibah, 496	5	265	
Sydney and Suburban Hydraulic Power Company's Bill, 496	2	1185	
West Maitland Cattle Sale Yards Bill, 519	2	1207	

REFERENCES TO THE VOTES AND PROCEEDINGS, VOL. I—13TH PARLIAMENT—SESSION, 1887-8.	PAPERS.	
	VOL.	PAGE.
R		
REPORTS—(continued) :—		
FROM SELECT COMMITTEES—(continued) :—		
Goulburn and Tuena Tramway Bill, 523.....	2	907
Broken Hill Water Supply Bill, 537.....	2	863
Cooma Church of England Lands Sale Bill, 547.....	2	901
Mineral Conditional Purchases, parish of Metz, 572.....	8	439
Messrs. Hugh McNeill and party's Mineral Lease at Captain's Flat, 592.....	8	491
Claim of Isaac Barclay, 609.....	5	487
Combination Trucks, 626.....	6	815
RESERVES (See also "MINING"; also "WATER SUPPLY;" also "RECREATION RESERVES").		
RESOLUTIONS (See also "FINANCE").		
FROM COMMITTEE OF THE WHOLE :—		
Reported, 29 (3), 42 (2), 49, 70, 107 (2), 108, 114, 115, 123, 161, 163 (2), 193, 201 (2), 253, 259, 321 (2), 335, 365, 386, 455, 494, 543, 561, 580, 602.		
Agreed to, 29 (3), 42 (2), 49, 70, 107 (2), 108, 114, 115, 123, 162, 166 (2), 193, 201 (2), 253, 259, 321 (2), 335, 366, 455, 494, 544, 561, 580, 602.		
FROM COMMITTEE OF SUPPLY :—		
Reported, 201, 242, 295, 345, 409, 480, 553, 619.		
Agreed to, 201, 242, 295, 345, 409, 480, 553, 625.		
FROM COMMITTEE OF WAYS AND MEANS :—		
Reported, 242, 248, 295, 346, 409, 430, 554, 627.		
Received, 346, 409, 430, 554, 627.		
Agreed to, 242, 248, 295, 346, 409, 430, 554, 627.		
RESUMPTION OF LAND (See also "EDUCATION"; also "RAILWAYS").		
NOTIFICATIONS OF, LAID ON TABLE :—		
Water Supply purposes, 5, 165, 613.....	5	871, 873, 875
Military Road, South Head to Ben Buckler and Bondi, 22.....	2	65
Road along Main Sewer to Bondi, Old South Head Road to Forts, Bondi, 22.....	5	1019
Public School purposes, 70, 155, 246, 257, 341, 360, 408, 496, 553, 608.....	4	525 to 545
Extension of Parramatta Gaol, 231.....	4	1227
Public Cemetery at Singleton, 252.....	8	1223
Under 6th section of 44 Victoria No. 16, 314.....	5	683
Daysdale Tank, 415.....	8	951
Public wharf near Frederickton, Macleay River, 432.....	3	1049
Wharf, &c., near Ghinny Ghinny, Manning River, 475.....	3	1051
Sydney Sewerage Works, 613.....	5	877
RETIREMENT OF MR. JONES (See "CLERK OF LEGISLATIVE ASSEMBLY").		
RETIRED ALLOWANCES (See "CIVIL SERVICE").		
REVENUE (See also "FINANCE") :—		
FROM ELECTORATES OF GRAFTON AND THE CLARENCE :—		
Motion made (<i>Mr. See</i>) for a Return showing, since 1861, 128.		
REVENUE RECEIPTS AND EXPENDITURE :—		
Abstracts of, for quarter ended 30th June, 1888, laid on Table, 561 (not printed).		
RICHARDSON JOSEPH, CLAIM OF (See "ROADS").		
RICHMOND RIVER (See also "PARLIAMENTARY STANDING COMMITTEE ON PUBLIC WORKS") :—		
EXPENDITURE ON ROADS AND BRIDGES, AND TOTAL REVENUE FROM DISTRICT :—		
Return (<i>in part</i>) to Order (<i>Second Session</i> , 1887) laid on Table, 28.....	5	1023
STEAM TUGS FOR :—		
Conditions respecting the Employment of, laid on Table, 165.....	3	1065
Report by Sir John Coode on the Entrance to, laid on Table, 462.....	3	905
NOXIOUS WEEDS :—		
Motion made (<i>Mr. Ewing</i>) for report and papers in connection with, 546; Return to Order, laid on Table, 578.....	8	983
RINGBARKING ON CROWN LANDS :—		
Motion made (<i>Dr. Ross</i>) for Return showing area and list of runs on which permission has been granted for, 325; Return to Order, laid on Table, 613.....	5	507
ROADS (See also "MUNICIPAL ROADS AND STREETS BILL"; also "WHALING ROAD") :—		
ADDITIONAL VOTE OF £100,000 :—		
Return respecting the Expenditure of, laid on Table, 6.....	5	965
MILITARY, FORTIFICATIONS AT SOUTH HEAD TO BEN BUCKLER AND FORTS NEAR BONDI :—		
Notification under Lands for Public Purposes Acquisition Act for resumption of land for, laid on Table, 22.....	2	65
ALONG MAIN SEWER, BONDI, AND TO CONNECT OLD SOUTH HEAD WITH FORTS AT BONDI :—		
Notification under Lands for Public Purposes Acquisition Act for resumption of land for, laid on Table, 22.....	5	1019
COOMA TO BOMBALA :—		
Motion made (<i>Mr. Dawson</i>) for a return of money expended on, from 1877 to 1887, 22; Return to Order, laid on Table, 58.....	5	993
AND BRIDGES IN THE ELECTORATE OF THE RICHMOND :—		
Return (<i>in part</i>) to Order (<i>Second Session</i> , 1887), laid on Table, 28.....	5	1023
CLAIM OF JOSEPH RICHARDSON AGAINST THE DEPARTMENT :—		
Motion made (<i>Mr. Wall</i>) for a Select Committee to inquire into, 36.		
MESSRS. LEONARD AND BATHGATE'S CANCELLED CONTRACTS :—		
Motion made (<i>Mr. Stokes</i>) for all correspondence, reports, minutes, &c., reference to, 103; Return to Order laid on Table, 231.....	5	995
PARISH :—		
Motion made (<i>Mr. O'Sullivan</i>) for a return showing those which have been asked to be opened which are still kept closed, and where situated, 168.		
AUBURN PARK TRUST :—		
Motion made (<i>Mr. Frank Farnell</i>) for all papers and minutes in connection with, 196; Return to Order, laid on Table, 341.....	5	997
SUBORDINATE :—		
Schedule showing classification and proposed distribution of Vote for 1888, under Officers of the Department, laid on Table, 224.....	5	949
Schedule, showing classification and proposed distribution of Vote for 1888, under Trustees, laid on Table, 224.....	5	943
VOTE OF £25,000 ON ESTIMATES FOR 1888 :—		
Schedule showing distribution, laid on Table, 224.....	5	963

REFERENCES TO THE VOTES AND PROCEEDINGS, VOL. I—13TH PARLIAMENT—SESSION, 1887-8.		PAPERS.	
		VOL.	PAGE.
R			
ROADS—(continued):—			
TULCUMBA TO GUNNEDAH :—			
Motion made (<i>Mr. J. P. Abbott</i>) for papers, &c., 288; Return to Order, laid on Table, 537	5		987
GLENTHORNE AND PURFLEET, MANNING RIVER :—			
Motion made (<i>Mr. Sydney Smith</i>) for papers having reference to, 437; Return to Order, laid on Table, 524.....	5		973
Trust Accounts for the half-year ending 30 June and 31 December, 1887, laid on Table, 505	5		937
GRANTS WITHIN MUNICIPAL BOUNDARIES :—			
Return respecting, laid on Table, 635	2		271
ROBERTSON, MR. THOMAS :—			
Letter from, read by Mr. Speaker, apologizing for having interrupted the Proceedings of the House, and apology accepted, 79.			
ROBERTSON (See "RAILWAYS").			
ROBERTS, RAILWAY TRAFFIC INSPECTOR (See "RAILWAYS").			
ROCKDALE MUNICIPALITY NAMING BILL :—			
Motion made (<i>Mr. Carruthers</i>) for leave to bring in, presented and read, 1 ^o , 103; read 2 ^o , committed, reported without amendment, and report adopted, 192; read 3 ^o , passed and sent to Council, 208; returned with amendments, 264; Council's amendments agreed to, Message to Council, 417; assent reported, 462.			
ROGERS ALEXANDER (See "CROWN LANDS PURCHASES VALIDATION BILL").			
ROLLS (See "ELECTORAL").			
ROSEHILL RACECOURSE (See "TELEGRAPHS").			
ROSS, WILLIAM (See "NATIONAL PARK").			
ROSSI, CAPTAIN :—			
CLAIMS OF :—			
Motion made (<i>Mr. Hurley</i>) for a Select Committee to consider, 36; Return to Address (<i>Session</i> , 1883-4) referred, 184; Report brought up, 263; Motion made (<i>Mr. Hurley</i>) for adoption of Report, and the Question not being put at 7 o'clock, Government Business takes precedence, 560.	2		143
Petition presented from, asking leave to be heard before the Bar of the House or the Select Committee, in opposition to the Church of England Property Bill, 538	2		897
Petition presented in reference to St. Saviour's Glebe Land Leasing Bill, 246.....	2		1087
ROUSE, MRS. ANN (See "CROWN LANDS").			
ROYALTY ON OYSTERS ABOLITION BILL :—			
Motion made (<i>Sir Henry Parkes</i>) for leave to bring in, 140; presented and read 1 ^o , 140; read 2 ^o , committed, reported without amendment, and report adopted, 165; read 3 ^o , passed and sent to Council, 169; returned without amendment, 197; Assent reported, 219.			
RULES :—			
Under Volunteer Force Regulation Act, of 5th Regiment Scottish Rifles, laid on Table, 6.....	2		39
Supreme Court, laid on Table, 257, 635	2		709, 711
Bankruptcy Act, laid on Table, 267.....	2		727
RULINGS OF SPEAKER (See also "SPEAKER") :—			
On Points of Order arising in the House, 4, 24, 42, 49, 156, 192, 224, 252, 259, 315, 426, 433, 455, 574, 587, 599, 635.			
Dissent from, moved and withdrawn 49.			
Do. moved and negatived, 4, 24, 25, 156-7, 565.			
RUSHCUTTERS BAY ACT AMENDMENT BILL :—			
Motion made (<i>Mr. J. P. Abbott</i>) for leave to bring in, 287; presented and read 1 ^o , 356; Order of the Day discharged and Bill withdrawn, 508.			
S			
SAINT JAMES' PARSONAGE LAND LEASING BILL :—			
Assent reported (<i>passed in the last Session</i>), 2.			
SAINT SAVIOUR'S GLEBE LAND LEASING BILL :—			
Petition presented (<i>Mr. Colls</i>) for leave to bring in, 237; leave given, presented, and read 1 ^o , 241; referred to Select Committee, 246; Report brought up, 314	2		1079
Petition from F. R. L. Rossi, Trustee, in opposition to the passing of the Bill, presented, 246	2		1087
SALARIES OF CIVIL SERVANTS (See "CIVIL SERVICE").			
SAND-DRIFT (See "NEWCASTLE SAND-DRIFT RECLAMATION ACT REPEAL BILL").			
SANKEY, PATRICK, THE CASE OF :—			
Return to Order (<i>Session</i> , 1887) laid on Table (not printed), 304.			
SAVAGE, CAPTAIN A. H. P. (See "MILITARY").			
SAVAGE, THE MISSES :—			
Petition presented in reference to claim for services by their late father, and praying the House to take their case into favourable consideration, and read by the Clerk, 565	8		1295
SAVINGS BANK, GOVERNMENT :—			
Statement of accounts for 1887, 356.....	3		819
SCHAW, MAJOR-GENERAL (See "MILITARY").			
SCHEDULE :—			
Showing classification and proposed distribution of Vote for 1888, for subordinate roads under the officers of the Department, laid on Table, 224	5		949
Showing classification and proposed distribution of Vote for 1888, for subordinate roads under Trustees, laid on Table, 224	5		943
Showing proposed distribution of Vote of £55,000 on Estimates for 1888 for Bridges, laid on Table, 224.....	5		965
Showing proposed distribution of Vote of £25,000 for 1888 for Roads, laid on Table, 224	5		963
To Estimates-in-Chief, for 1888, showing the total remuneration received by all Public Officers, laid on Table, 223	3		153
SCHOOL ATTENDANCE OFFICERS (See "EDUCATION").			
SCHOOLS (See "EDUCATION," also "CHURCH AND SCHOOL LANDS MINING BILL").			
SEAVER, JONATHAN C. B. P., Esq., M.P. :—			
Leave of absence granted to, 361.			
SEDUCTION PUNISHMENT BILL :—			
Motion made (<i>Mr. J. S. Farnell</i>) for leave to bring in, presented, and read 1 ^o , 40; Order of the Day postponed, 77, 107, 145, 169, 192, 224; read 2 ^o and committed, 253; Order of the Day postponed, 285; further considered in Committee and reported with amendments, report adopted, 321; Order of the Day postponed, 484.			

REFERENCES TO THE VOTES AND PROCEEDINGS, VOL. I—13TH PARLIAMENT—SESSION, 1887-8.		PAPERS.	
		VOL.	PAGE.
S			
SELECT COMMITTEES (See also "REPORTS") :—			
Appointed by ballot, 30.			
Authorized to make visits of inspection, 155, 287.			
Evidence, &c., of previous Session referred to, 115, 140.			
Leave granted to Clerk to return documents handed in before, 88, 468.			
Members name removed from, 432, 462.			
Do substituted for another on, 585.			
Papers referred to, 52, 161, 184, 424, 463.			
Petitions referred to, 40 (?), 122, 135, 165, 192, 215, 232, 324, 328, 341, 403, 491.			
Prayer of Petition granted to be heard in person or by Counsel before, 144, 150, 161, 181, 192, 208, 294.			
Proceedings and Evidence of (<i>previous Session</i>), laid on Table by Clerk, 71, 115, 140.			
Report from, referred back, 200.			
Sessional Order relative to balloting for, passed, 11.			
Vote of Chairman of, on Private Bills, Sessional Order passed, 11.			
Bill referred back to, 487.			
Motion made (<i>Mr Barbour</i>) for Committee of the Whole to consider the question of remuneration to Members attending on Private Bill Committees, 608.			
Abstract of Standing, appointed during the Session	1		831
SELECTIONS (See "CROWN LANDS")			
SEMPILL (See "DISTRIBUTION OF FUNDS IN SEMPILL'S ESTATES BILL")			
SERGEANT-AT-ARMS :—			
Motion made to commit Member adjudged guilty of contempt to custody of, 156; and withdrawn, 157.			
Removes Members from the Chamber, 220 (?), 221 (?), 345.			
Speaker's Warrant issued committing Member to custody of, 480.			
Member in custody of, 483.			
Member discharged from custody, 486.			
SESSIONAL ORDERS :—			
Passed 9, 10 (?), 11 (?), 12 (?), 89 (?), 103, 408.			
Hour of Meeting of the House, 224.			
Rescinded (Friday's sitting), 325.			
Precedence of Government Business on Tuesdays, 408.			
Friday Sitting Day, General Business to take precedence, 585; Monday Sitting Day, Government Business to take precedence, 585.			
SEWERAGE (See "WATER SUPPLY"; also "METROPOLITAN WATER AND SEWERAGE ACT AMENDMENT BILL"; also "COUNTRY TOWNS WATER AND SEWERAGE ACT EXTENSION BILL")			
Report of Mr. G. H. Stayton, M. Inst. C.E., on Western Suburbs, laid on Table, 267; Plan laid on Table (<i>to be appended to Mr. Stayton's Report</i>), 613; Sections of proposed Sewers (<i>to be appended to Mr. Stayton's Report</i>), laid on Table, 635.	5		895
SYDNEY :—			
Return respecting Contract for laying Cast-iron Syphon, George-street West, Contract No. 35, laid on Table, 608; Notification of resumption of land in connection with Works for, laid on Table, 613	5		933
SHAW, THOMAS (See "CROWN LANDS BILL, No. 2")			
SHEA, JEREMIAH :—			
Petition from, that he was sent to the Colony in 1818, that he is now 88 years of age, that he discovered gold in the Northern Fields in 1852, but has received no acknowledgment for the same, and he is now through age and infirmity unable to earn his living, and praying relief, presented, 112	8		1217
SHEPHERD v. LEONARD (See "ADMINISTRATION OF JUSTICE")			
SHIPPING (See "STATISTICS")			
SHORT-HAND WRITING SERVICES :—			
Motion made (<i>Mr. Walker</i>) for a return showing amount paid for, in connection with each Commission and Board of Inquiry since 1st January, 1886, also the number and name of Commissions and Boards of Inquiry attended by <i>Hansard Staff</i> , 232.			
SICK POOR OF THE METROPOLIS :—			
ADDITIONAL ACCOMMODATION :—			
Motion made (<i>Mr. E. B. Wilkinson</i>) for correspondence respecting, 493.			
SILVER ORE :—			
Return respecting, carried on Railway, laid on Table, 635	6		749
SILVERTON (See "RAILWAYS")			
SILVERTON TRAMWAY ACT AMENDING BILL :—			
Standing Orders suspended, to admit of presentation of Petition to bring in, 294.			
Petition presented (<i>Mr. Day</i>) for leave to bring in, 295; leave given, presented, and read 1 ^o , 303; referred to Select Committee, 308; Report brought up, 348; read 2 ^o , committed, reported without amendment, report adopted, 421; read 3 ^o , passed and sent to Council, 425; returned with amendments, 593; Order of the Day postponed, 619; amendments agreed to, 641; assented to in Legislative Council Chamber, 642.	2		1089
Petition of Charles Bath to be heard by Counsel, Attorney, or Agent, before the Select Committee, presented, 341	2		1097
SIMPSON, THE HONORABLE G. B. :—			
Acceptance of Office of Attorney-General by, 264.			
SINGLETON (See "CEMETERY")			
SIXPENCES, DESIGN FOR COINING (See "COINAGE")			
SKENE, WILLIAM, PRELEASE OF, AT CONARGO (See "CROWN LANDS")			
SLATTERY, THOMAS MICHAEL, ESQUIRE, M.P. :—			
Appointed Chairman of Committees for the day only, 70, 342, 344, 348.			
Declared guilty of persistent disorder and removed by Sergeant-at-Arms from the Chamber, 220.			
Appointed with three others to act temporarily as Chairman of Committees, in the absence of the Member appointed to that office, 389.			
Speaker calls on, to act as Deputy Chairman of Committees, for the day only, 408, 524.			
PRIVILEGE—<i>Slattery v. Young</i> :—			
Speaker reported receipt of letter from Mr. P. J. Hourigan, Solicitor, that, at instance of Mr. Slattery, he had issued a writ against him to recover damages for having caused Mr. Slattery to be removed from the Chamber; motion made (<i>Sir Henry Parkes</i>) that Mr. Speaker have leave to appear and plead, that Crown Solicitor accept service of the Writ, and that Attorney-General defend the action, 228.			
SLEEPING BERTH (See "RAILWAYS")			

REFERENCES TO THE VOTES AND PROCEEDINGS, VOL. I—13TH PARLIAMENT—SESSION, 1887-8.	PAPERS.	
	VOL.	PAGE.
S		
SMELTING WORKS (See "MINING").		
SMITH, MR. J. A., PUBLIC SCHOOL TEACHER AT COOLA CREEK (See "EDUCATION").		
SMITH, THE HONORABLE JOHN (See also "CROWN LANDS") :—		
LANDS HELD BY, IN DISTRICT OF MOLONG :—		
Motion made (<i>Dr. Ross</i>) for a return showing, under Orders in Council, the area of each portion, and why granted, 155; Return to Order laid on Table, 219.....	5	445
SOUTH WARATAH COLLIERY (See "MINING").		
SPEAKER :—		
Names a member for disorderly conduct, 156 (2), 184.		
Declares Members guilty of persistent disorder, and directs the Sergeant-at-Arms to remove them from the Chamber, 220 (?), 221 (?).		
Directs removal of Member by Sergeant-at-Arms, 345.		
Reports resignation of Member, 1, 73, 222, 269, 419.		
Reports issue and return of Writ, 1, 73, 87, 249(3), 303, 339, 463.		
Acquaints House of receipt of telegram conveying special thanks of Her Most Gracious Majesty the Queen for the Address of Congratulation on the completion of the Jubilee Year of Her Reign, 2.		
Acquaints House of receipt of Message from the Governor assenting to Bill passed during previous Session, 2.		
Lays on Table Statement of Receipts and Expenditure for 1886, with Auditor-General's Report, 2	3	509
Lays on Table Statement of Receipts and Expenditure for 1887, with Auditor-General's Report, 563	3	657
Reports attendance of House in Council, and reads Governor's Opening Speech, 2.		
Presents Address in Reply to Governor's Opening Speech, and reports Answer thereto, 5.		
Reports receipt of Deputy Speaker's Commission to administer Oath, 19.		
Lays Warrant appointing Elections and Qualifications Committee upon Table, 17, 269; reports maturity, 37, 287; appoints first meeting of Committee, 53.		
Inform House that Clerk had been summoned, 89, 351.		
Inform House of irregularities at an election and issue of Proclamation curing same, 73.		
Reports letter from Mr. Thomas Robertson, apologising for having interrupted the Proceedings of the House, 79.		
Announces course intended to be followed in carrying out Resolution that Entry be expunged from Votes and Proceedings, 91.		
Instructed by Resolution as to course to be followed in carrying out Resolution that Entry in Votes and Proceedings be expunged, 91.		
Authorized to present Additional Standing Order to Governor for approval, 28.		
Reports Governor's approval of Additional Standing Order, 31.		
Reports receipt of letter from Clerk, reporting that a document laid on the Table had not been returned to his custody by a Member who had had the use of it, 51.		
Reports retirement of Stephen W. Jones, Esq., Clerk of Legislative Assembly, 250.		
Notice of Motion to rescind appointment of Mr. James Henry Young, 252.		
Lays on Table Election Petition, <i>Hellmrich v. W. J. Allen</i> , Paddington, 269.		
Calls on a Deputy Chairman of Committees to act for the day only, 397, 403, 408, 416, 420, 425, 429, 432, 437, 442, 451, 454, 463, 468, 476, 479, 484, 493, 496, 500, 506, 513, 519, 524, 532, 538, 543 (2), 547, 560, 565, 573.		
Issues Warrant committing Member to custody of Sergeant-at-Arms, 480.		
Vacates Chair when motion couched in terms personal to himself is to be discussed; resumes Chair, and motion proceeded with, 579.		
Motion made (<i>Mr. Buchanan</i>) setting forth the qualifications essential to the Chairman or Speaker, that the present occupant of the Chair is deficient in the knowledge essential in anyone holding the office, and that his frequent interference is the cause of much disorder, and negatived, 579.		
RULINGS OF :—		
Motion made to dissent from, and negatived, 4, 24, 49, 156, 565.		
That it is not in order, on the motion for the adoption of the Address in Reply, to speak of any private transactions between a Minister and any person outside, that the matter was not relevant, and that any charges should be made on a specific motion, 4.		
That, on the question "That the question be now put," when there are no voices for the Noes, and when the Chair is satisfied there are forty Members present, it is not necessary to take a division, 24.		
That the Albury Cattle Sale-yards Bill, notwithstanding that the Select Committee to whom it was referred had decided at one sitting against a motion to report the Bill with amendments to the House, was not out of order, 42, 43.		
That language reflecting on the Chief Commissioner of Insolvent Estates, now an Acting Judge of the Supreme Court, infringes the rules of Debate, 49.		
That a motion adjudging a Member ("named" by Mr. Speaker) guilty of contempt can be put from the Chair, notwithstanding that the question "That the Question be now put" has been put from the Chair and is undecided, 156.		
That Registered Medical Practitioners Bill contains provisions not authorized by the Order of Leave, 192.		
That to challenge the action of the Chair under cover of a Motion for Adjournment of the House would be out of order, 224.		
That Notice of Motion to rescind appointment of Speaker was not out of order, and that motion submitted "That no Resolution reflecting upon the Speaker be entered on Votes and Proceedings" could not be put as one of Privilege, 252.		
That the Public Works Bill did not contain provisions beyond the Order of Leave, 259.		
Discussing Bill in detail on second reading, 315.		
That Councils amendments in Government Railways Bill, do not infringe on Rights of Assembly, 426.		
That Estimates were properly before the House, notwithstanding the Salaries therein shown were lower than those provided by the Civil Service Act, 433.		
That Schedules A, B, and C on Estimates are not open to discussion, as they are already provided for by Acts of Parliament, 433.		
Declines to overrule the opinion of the Chairman in reference to words used by Mr. McElhone in Committee of Supply, 452.		
That clause 3, of Chinese Restriction and Regulation Bill was not beyond order of leave, 455.		
That amendment made in Land Tax Bill was in order, 587.		
That Church of England Property Bill, although introduced in the Council as a Private Bill, should, under the 69th Standing Order, be treated as a Public Bill in the Assembly, 599.		
That by a previous decision of the House he had been relieved of the responsibility of determining whether, on a motion of adjournment, the matter stated in the notice was of urgent public importance, and that the objection should have been taken before the question was stated, 635.		

REFERENCES TO THE VOTES AND PROCEEDINGS, VOL. I—13TH PARLIAMENT—SESSION, 1887-8.	PAPERS.	
S	VOL.	PAGE.
SPEAKER—(continued):—		
PRIVILEGE :—		
Acquaints House of receipt of letter from Mr. P. J. Hourigan, Solicitor, that at instance of Mr. Slattery, he had issued a Writ against Mr. Speaker, to recover damages for having caused Mr. Slattery to be removed from the Chamber; motion made (<i>Sir Henry Parkes</i>) that Mr. Speaker have leave to appear and plead, that Crown Solicitor accept service of Writ, and the Attorney-General defend the action, 228.		
SPECIAL ADJOURNMENT :—		
Motion made for, and passed, 1, 128, 216, 246, 232, 314, 353 (<i>Easter</i>), 456, 467 (<i>Queen's Birthday</i>).		
SPECIAL AUDIT (See "MUNICIPAL").		
SPECIAL GRANTS TO MUNICIPALITIES :—		
Motion made (<i>Mr. Creer</i>) for Committee of the Whole to consider an Address to the Governor for, 404; Order of the Day discharged, 508.		
SPIRITS :—		
WINES AND BEER :—		
Annual Return to Order, laid on Table, 560	7	681
SPIT, MIDDLE HARBOUR (See "PARLIAMENTARY STANDING COMMITTEE ON PUBLIC WORKS").		
ST. LEONARDS (See also "NORTH SHORE BOROUGH'S WHARVES BILL"; also "ELECTORAL"; also "RAILWAYS"; also "CROWN LANDS BILL No. 2") :—		
Proclamation, under the Public Parks Act of 1884, extinguishing, as a public highway, part of the Recreation Reserve, laid on Table, 6	5	811
ST. PETER'S-LIVERPOOL LINE (See "RAILWAYS").		
ST. THOMAS CHURCH ENFIELD LANDS SALE BILL :—		
Received from Legislative Council, and on motion (<i>Mr. J. P. Abbott</i>), read 1 ^o , 462; read 2 ^o , committed, reported without amendment, report adopted, 507; read 3 ^o , passed, returned to Council, 524; assent reported, 539.		
STAFFORD WILLIAM, EX-SERGEANT OF POLICE :—		
Motion made (<i>Mr. O'Sullivan</i>) for papers respecting dismissal of, 338; Return to Order laid on Table, 352	4	1215
Petition presented (<i>Dr Ross</i>) in reference to dismissal of 425	4	1221
STAMP DUTIES ACT :—		
ALLEGED FRAUD UNDER :—		
Motion made (<i>Mr. O'Sullivan</i>) for all papers, correspondence, &c., in the recent case of, in connection with certain land at Queanbeyan, 40; Return to Order, laid on Table, 174	8	1265
STANDING ORDERS :—		
65th entertained, to permit a Private Bill being taken up at the stage at which it was left in a previous Session, 9, 17, 22, 23, 35, 98.		
61st suspended, to admit of presentation of Petition for Private Bill, 294, 361.		
Suspension of, to enable Bill to pass through remaining stages in one day, 191.		
Do. do all stages in one day, 241, 295, 326, 314, 409, 455, 479, 553, 578.		
Motion made (<i>Mr. Burns</i>) that the suspension of certain, is a matter of urgent and pressing necessity, 241.		
Motion made (<i>Sir Henry Parkes</i>) to suspend, as a matter of urgency, to appoint a Chairman of Committees for the day only, 385.		
Motion made (<i>Mr. J. P. Abbott</i>) to refer the whole to Standing Orders Committee for consideration, revision, amendment, and report, and that Committee have leave to sit during adjournment or prorogation of the House, and amended (<i>Mr. M'Millan</i>) by omission of words giving leave to sit during adjournment and prorogation, 353; Report brought up, 476; ordered to be considered in Committee, 479; Order of the Day postponed, 529, 566, 592.	1	819
STANDING AND SELECT COMMITTEES :—		
Abstract of, appointed during the Session	1	831
ADDITIONAL (RIGHT OF REPLY) :—		
Motion made (<i>Mr. J. P. Abbott</i>), that, whenever it shall have been decided that any Question shall be put, thereupon, and after it has been so decided, but before such Question be put, the mover of the matter pending shall be permitted to speak in reply under certain restrictions, 23; motion made (<i>Mr. Abbott</i>), authorizing Mr. Speaker to present to the Governor for approval, 28; approval reported, 31.		
ADDITIONAL No. 5 :—		
Motion made (<i>Mr. Moore</i>) that Additional Standing Order No. 5, adopted and approved May, 1887, being in contravention of the 23rd section of the Constitution Act, is <i>ultra vires</i> , 128; and negatived, 129.		
COMMITTEE :—		
Sessional Order, passed, 11.		
Name added to, 89, 280.		
Standing Orders referred to, 353.		
STANLEY, MR. (See "RABBIT PEST").		
STATE CHILDREN'S RELIEF DEPARTMENT :—		
Report on, for year ended 5th April, 1888, laid on Table, 565	4	753
STATE FORESTS AND FOREST RESERVES :—		
Return of trees planted in, laid on Table, 273	5	797
Notification of amendment and cancellation of Regulations laid on Table, 360	5	595
STATE HOUSE (See also "CENTENARY CELEBRATION ACT AMENDMENT BILL") :—		
Motion made (<i>Mr. Dibbs</i>) for Committee of the Whole to consider expediency of bringing in a Bill to appropriate the sum of £150,000, from the proceeds of sale of portion of the Centennial Park, for erection of a State House to be used as Houses of Parliament in Macquarie-street, 60; Order of the Day postponed, 103, 192 (?), 252, 508; discharged, 586.		
Report of Board on Competitive Designs for, laid on Table, 196	8	1279
Motion made (<i>Mr. Copeland</i>) that this House do now adjourn to draw attention to proposed expenditure on, and withdrawn, 246.		
STATE QUARRIES :—		
Notifications of Amendment and cancellation of Regulations under the Crown Lands Act of 1884, laid on Table, 360	5	595
STATISTICS :—		
Statistical Register for: 1887.		
Do Part III. Trade and Commerce, laid on Table, 352		
Do Part I. Population Immigration and Vital, laid on Table, 442		
Do Part IV. "Works and Manufactories", laid on Table, 479		
Do Part II. Crime and Civil Justice, laid on Table, 547		
Do Part VI. Production, laid on Table, 547		
Do Part VII. Education, Religion, and Charities, laid on Table, 547		
Do Part V. Monetary and Financial, laid on Table, 608		
Do Part VIII. Miscellaneous, Laid on Table, 626	7	979

REFERENCES TO THE VOTES AND PROCEEDINGS, VOL. I—13TH PARLIAMENT—SESSION, 1887-8.		PAPERS.
S		
	VOL.	PAGE.
STATISTICS (continued) :—		
CENSUS :—		
Return showing estimated population on 31 December, 1887, of New South Wales and Victoria respectively, 352	7	1393
LIVE STOCK :—		
Return of, in the Australasian Colonies, 1871, 1881, 1887, laid on Table, 565	8	597
PROGRESS OF THE COLONY OF NEW SOUTH WALES :—		
Statistical View of—since separation of Queensland, laid on Table, 462.	7	1395
SHIPPING AND IMPORTS AND EXPORTS :—		
Australasian, during the year 1887 and previous years, laid on Table, 519	7	1397
STAYTON, MR. G. H., M. INST. C.E. :—		
SEWERAGE AND DRAINAGE OF THE WESTERN SUBURBS :—		
Report laid on Table, 267; Plan laid on Table (<i>to be appended to the Report</i>), 613; Sections of Sewers in connection with Report of, laid on Table (<i>to be appended to the Report</i>), 635	5	895
STEAM TUGS (See "TUGS").		
STEVENS, CHARLES :—		
CLAIM OF :—		
Report of Select Committee adopted, 268.		
STEVENSON JAMES C. (See "CROWN LANDS").		
STIPENDIARY MAGISTRATE (See "ADMINISTRATION OF JUSTICE"; also "CIVIL SERVICE").		
STOCK (See also "LIENS ON WOOL BILL"; also "WATER SUPPLY"; also "PASTURES AND STOCK PROTECTION ACT AMENDMENT BILL"; also "DISEASES IN SHEEP AND IMPORTED STOCK ACTS;"; also "PASTURES AND STOCK PROTECTION BOARDS") :—		
BRANCH, DEPARTMENT OF MINES :—		
Annual Report for 1886, laid on Table, 6; do. for 1887, laid on Table, 408.....	8	543, 573
DRILLS AND BORING OPERATIONS :—		
Report of the Superintendent of Drills on the 101½-mile, Bourke to Wanaaring Road, laid on Table, 302	8	953
STRANGERS, EXCLUSION OF :—		
Sessional Order passed, 12.		
STREET NORTH OF THE GENERAL POST OFFICE (See "FORMATION OF STREET, GENERAL POST OFFICE").		
STREETS (See "MUNICIPAL ROADS AND STREETS BILL").		
SUMMONS TO THE CLERK :—		
Reported, and leave given to produce Records, 89, 351.		
SUNDAY TIMES :—		
Motion made (<i>Mr. Dibbs</i>) that this House do now adjourn to discuss the action of the police in prosecuting persons for selling, and negatived, 186.		
SUNDAY TRAFFIC (See "RAILWAYS").		
SUPERANNUATION (See "CIVIL SERVICE").		
SUPPLY (See also "FINANCE") :—		
Committee of, Sessional Order passed, 11.		
Motion made (<i>Mr. Burns</i>) for the House to go into Committee, 174, 295, 345, 409, 433, 452, 476, 480, 544, 548, 553, 554, 610, 613, 619.		
House in Committee, 201, 242, 295, 345, 409, 433, 452, 476, 480, 544, 548, 553, 554, 610, 613, 619.		
Resolutions reported, 201, 242, 295, 345, 409, 480, 553, 619.		
Resolutions agreed to, 201, 242, 295, 345, 409, 480, 553, 625.		
Point of Order reported from Committee, 452.		
SUPREME COURT (See also "NEW TRIALS LIMITATION BILL") :—		
Rules of, laid on Table, 257, 635	2	709, 711, 727
SUPREME COURT APPEALS ACT AMENDMENT BILL :—		
Motion made (<i>Mr. Wise</i>) for Committee of the Whole, 119; House in Committee, Resolution agreed to, presented and read 1 ^o , 123; Message from Governor, 135; read 2 ^o , committed, reported with an amendment, and report adopted, 140; read 3 ^o and passed, 144; sent to Council, 145; returned without amendment, 157; Assent reported, 168.	2	733
SURGERY (See "MEDICINE AND SURGERY").		
SURVEY OFFICE :—		
REMOVAL OF, FROM ALBURY TO WAGGA WAGGA :—		
Motion made (<i>Mr. Day</i>) for all reports, telegrams, and recommendations respecting, 41; Return to Order laid on Table, 476	5	101
SURVEYORS (See "LICENSED SURVEYORS").		
SUSPENSION OF STANDING ORDERS (See "STANDING ORDERS").		
SWAMP-STREET, DOUBLE BAY :—		
Motion made (<i>Mr. Neild</i>) for papers in reference to alienation of land known as, 429; Return to Order laid on Table, 484	8	1287
SWIFT, MR. :—		
CUSTOMS HOUSE OFFICER, BREWARRINA :—		
Motion made (<i>Mr. Waddell</i>) for papers, &c., in connection with dismissal of, 369; Return to Order laid on Table, 370	2	133
SWORN (See "MEMBERS").		
SYDNEY (See also "RAILWAYS"; also "CITY OF SYDNEY MAYORAL ELECTION BILL"; also "WATER SUPPLY") :—		
DR. BOTRELL'S CLAIM TO FORESHORES OF THE HARBOUR :—		
Motion made (<i>Mr. Lyne</i>) for all papers connected with, 40; Return to Order laid on Table, 185.	3	885
CITY OF SYDNEY IMPROVEMENT BOARD :—		
Annual Report for the year ended August, 1887, laid on Table, 112	2	269
SYDNEY AND SUBURBAN ELECTRIC LIGHTING BILL :—		
Petition presented (<i>Mr. H. H. Brown</i>) for leave to bring in, 231; leave given, presented, and read 1 ^o , 236; referred to Select Committee, 258; report brought up, 454	2	1099
SYDNEY AND SUBURBAN HYDRAULIC POWER COMPANY'S BILL :—		
Petition presented (<i>Mr. Frank Smith</i>) for leave to bring in, 415; leave given, presented and read 1 ^o , 421; referred to Select Committee, 425; report brought up, 496.....	2	1185
Petition presented (<i>Mr. Kethel</i>), Municipal Council of Sydney, stating objections, and praying the House not to pass this Bill until the Petitioners considered the same, 421	2	1181
SYDNEY CORPORATION ACT AMENDMENT BILL :—		
Motion made (<i>Mr. O'Connor</i>) for leave to bring in, presented and read 1 ^o , 12; read 2 ^o , committed, reported without amendment, and report adopted, 42; read 3 ^o , passed, and sent to Council, 48; returned with amendments, 229; Order of the Day postponed, 232; amendments agreed to, 242; Message to Council, 243; Assent reported, 250.		

REFERENCES TO THE VOTES AND PROCEEDINGS, VOL. I—13TH PARLIAMENT—SESSION, 1887-8.	PAPERS.	
	VOL.	PAGE.
S		
SYDNEY FREE PUBLIC LIBRARY :—		
Report from Trustees for 1887-8, laid on Table, 378.....	4	589
SYDNEY GRAMMAR SCHOOL :—		
Report for 1886, laid on Table, 235	4	573
Do 1887, laid on Table, 432	4	581
SYDNEY HARBOUR (See "PARLIAMENTARY STANDING COMMITTEE ON PUBLIC WORKS").		
SYDNEY HYDRAULIC-POWER COMPANY'S BILL :—		
Petition presented (<i>Mr. Garrard</i>) for leave to bring in, 257; presented and read 1 ^o , 263; referred to Select Committee, 268; report brought up, 349; read 2 ^o , committed, progress reported, and Question proposed,—That leave be given to sit again,—and the motion not having been put at 7 o'clock, Government Business took precedence, 421; Order of the Day postponed, 433, 476; leave given to Committee to sit again, 487; Order of the Day postponed, 579, 593, 602.	2	1129
Petition presented (<i>Mr. McMillan</i>), certain residents of Sydney in favour of the Bill, 420	2	1183
Petition presented (<i>Mr. Kethel</i>), Municipal Council of Sydney, stating objections, and praying the House not to pass this Bill until the Petitioners considered the same, 421	2	1181
SYDNEY MORNING HERALD :—		
Motion made (<i>Mr. Melville</i>) for adjournment of the House to consider attack on Member for Northumberland, 335.		
SYDNEY SEWERAGE (See "SEWERAGE").		
SYPHON (See "SYDNEY SEWERAGE").		
T		
TAMWORTH :—		
FIRE BRIGADES BOARD :—		
Regulations of, laid on Table, 6, 578	2	611, 613
TANKS AND WELLS :—		
CONSTRUCTION AND MAINTENANCE OF :—		
Motion made (<i>Mr. Waddell</i>) that so much of Return (<i>in part</i>) to Order (<i>Session 1883-4</i>) laid on Table on 19 November, 1884, as relates to tanks at Galathera and Boggy Creek, be printed, 174	8	945
Motion made (<i>Mr. Waddell</i>) that all papers, minutes, and reports respecting complaints by Mines Department against Mr. Bennett, Commissioner and Engineer for Roads as to, and all correspondence respecting loss and inconvenience through works of, being divided between the Works and Mines Departments, 174; Return to Order laid on Table, 252	8	671
Daysdale :—Notification of resumption of land for, laid on Table, 415	8	951
TARIFF :—		
DUTY ON IMPORTED TIMBER :—		
Petition from Saw-mill Proprietors and others, that the carrying of, will cripple the trade, and praying that the reduction of the duty be not sanctioned, presented, 240.....	3	879
PROPOSED NEW :—		
Petition from Residents of Broughton Creek, Broger's Creek, Broughton Vale, and Kangaroo Valley against the abolition of the Customs Duties on Farm Produce, presented, and read by the Clerk, 252	3	881
TATTERSALL'S CLUB BILL :—		
Received from Legislative Council, and on motion (<i>Mr. Thompson</i>) read 1 ^o , 346; read 2 ^o , committed, reported without amendment, report adopted, 421; read 3 ^o , passed and returned to Council, 425; assent reported, 435.		
TEACHERS (See "EDUCATION").		
TEARLE v. EDOLS (See "CROWN LANDS").		
TECHNICAL EDUCATION (See "EDUCATION").		
TELEGRAPHS :—		
COMMUNICATION WITH ROSERILL RACECOURSE :—		
Motion made (<i>Mr. Frank Farnell</i>), for papers in reference to, 320.		
LINE TO MILPARINKA OR MOUNT BROWNE :—		
Motion made (<i>Mr. Abbott</i>) for all correspondence, petitions, and reports in reference to the construction of a line from Wanaaring to Milparinka or to Mount Browne, or from Wilcannia to those places, 24; Return to Order laid on Table, 228	4	1143
ELECTRIC TELEGRAPH ACT :—		
Regulations under, respecting the reduction in Press Rates to New Zealand, and Messages in Cypher, laid on Table, 35.....	4	1161
Regulation under, regarding Messages in Cypher, laid on Table, 608.....	4	1165
Notification under, of the reduction in rates for the transmission of telegrams from Silverton and Broken Hill to South Australia, laid on Table, 75.....	4	1163
IRON POLES :—		
Return respecting, laid on Table, 199.....	4	1183
ARTICLES SUPPLIED TO DEPARTMENT BY KINGSBURY & Co. :—		
Return to Order (<i>Second Session, 1887</i>) laid on Table, 128	4	1167
Return respecting, laid on Table, 252	4	1173
"GULCHER" ELECTRIC MACHINE :—		
Motion made (<i>Mr. Thompson</i>) for all letters, minutes, &c., relating to, for lighting, purchased by Department, 147; Returns to Order laid on Table, 231, 273	4	1191, 1197
Motion made (<i>Mr. Wall</i>), that this House do now adjourn to direct attention to papers laid on Table, and negatived, 246.		
RATES BETWEEN NEW SOUTH WALES AND QUEENSLAND :—		
Papers respecting the proposed reduction of, laid on Table, 165	4	1157
MR. LEESON :—		
Motion made (<i>Mr. Hassall</i>) for all papers, &c., referring to case of, 165.		
HORSES SUPPLIED TO DEPARTMENT :—		
Return showing cost, &c., of, laid on Table, 385	4	1181
SITE OF OFFICE, ANGLEDOOL :—		
Motion made (<i>Mr. Waddell</i>) for papers in connection with, 493.		
EXTENSION OF LINES :—		
Motion made (<i>Mr. Waddell</i>) in reference to lines paying at commencement or not, 609.		
TELEPHONES :—		
Information respecting Multiple Cable, laid on Table, 267; further Return laid on Table, 385.....	4	1185, 1187
TELLERS (See "NO TELLERS").		

REFERENCES TO THE VOTES AND PROCEEDINGS, VOL. I—13TH PARLIAMENT—SESSION, 1887-8.	PAPERS.	
	VOL.	PAGE.
T		
TENDERS :—		
CALLED FOR BY THE DEPARTMENT OF PUBLIC WORKS :—		
Return to Order (<i>Second Session, 1887</i>), laid on Table, 6.....	6	707
HARBOURS AND RIVERS DEPARTMENT :—		
Castings for the Hunter River District, 308	3	913
TERALBA COAL-MINING RESERVE :—		
Adjournment of the House moved (<i>Mr. McElhone</i>) in reference to the Mineral Selections made by the Lane Family and Mr. Withers on, 493.		
Motion made (<i>Mr. McElhone</i>) for papers in connection with the Selections of the Lane Family, T. Garrett, Greville, and others, 500; Returns to Order laid on Table, 547, 580; referred to Select Committee, 587; Order for Printing rescinded, 592.		
Motion made (<i>Mr. McElhone</i>) for Select Committee on Selections of Lane Family, Henry T. Withers, and William Thorne, 502; Name of Sir Henry Parkes substituted for name of Mr. J. P. Abbott on, 585; Papers referred to Committee, 587.		
Plan of Reserves Nos. 83 and 60, showing Mineral Conditional Purchases and Mineral Leases held thereon, laid on Table, 547.		
THEATRES (See also "PLACES OF PUBLIC AMUSEMENT OR RESORT") :—		
Report on, and other public places of amusement, laid on Table, 128	8	1209
THEFTS (See "WORKMEN'S TOOLS").		
THOMPSON, R. W., ESQUIRE, M.P. :—		
Name added to Select Committee on Crown Lands Purchases Validation Bill, 280.		
Name discharged from Select Committee, Resumption of Edward Irby's land at Bluff River, 432.		
THOMPSON, THOMAS, CONDITIONAL PURCHASE OF (See "CROWN LANDS").		
THORNE, WILLIAM (See "TERALBA COAL-MINING RESERVE").		
THROUGH-TICKETS, SYDNEY TO BRISBANE (See "RAILWAYS").		
TIERNY, JOHN—CONDITIONAL PURCHASE OF (See "CROWN LANDS").		
TIMBER DUTY (See "TARIFF").		
TIMBER LICENSES :—		
Motion made (<i>Mr. Waddell</i>) for abolition of, for timber used for Smelting Purposes, 608.		
TIMBER (See "STATE FORESTS AND FOREST RESERVES; also "CROWN LANDS").		
TIN-MINE AT PHEASANT'S CREEK (See "MINING").		
TOLLS AND FERRY DUES ON GOVERNMENT FERRIES :—		
Motion made (<i>Mr. Bowes</i>) for abolition of, 608.		
TOM, WILLIAM, JUN. (See "MINING").		
TOOHEY, MR. :—		
A MEMBER FOR SOUTH SYDNEY :—		
Named by Mr. Speaker, motion made adjudging him guilty of contempt and committing him to custody of Sergeant-at-Arms, 156; apology made to House for causing disorder, and motion withdrawn, 157.		
TOTALIZATOR LEGALIZING BILL :—		
Motion made (<i>Mr. Frank Farnell</i>) for leave to bring in, 273; presented, and read 1°, 324; Order of the Day postponed, 341, 361, 476, 493, 579, 593.		
Petition from Members of Clarence River Jockey Club, in favour of, presented, 285.....	8	1303
TRADE AND COMMERCE (See "STATISTICS").		
TRADE IN WHEAT BETWEEN SYDNEY AND BARCELONA :—		
Despatch respecting, laid on Table, 335, 475	8	1309, 1311
TRADE MARKS :—		
Petition presented (<i>Mr. Carruthers</i>) from Manufacturers and Merchants of Sydney stating that they are suffering from the loss of empty packages, vessels, &c., bearing their trade marks, and praying for an amendment of the present Act, 416	8	1301
TRADE MARKS AMENDMENT BILL :—		
Motion made (<i>Mr. Carruthers</i>) for leave to bring in, presented and read 1°, 421; Order of the Day postponed, 508.		
TRADES CONCILIATION BILL :—		
Motion made (<i>Mr. Carruthers</i>) for Committee of the Whole, 52; Order of the Day postponed, 65, 107, 131, 288; House in Committee, Resolution agreed to, 321; presented, and read, 1°, 342; referred to Select Committee, 386.		
TRAFFIC (See "RAILWAYS").		
TRAMWAYS (See also "GOVERNMENT RAILWAYS BILL"; also "HAY AND DENILQUIN TRAMWAY BILL"; also "NORTH SHORE, MANLY, AND PITTWATER TRAMWAY AND RAILWAY BILL"; also "BROKEN HILL TRAMWAY BILL"; also "SILVERTON TRAMWAY ACT AMENDING BILL"; also "KIAMA TRAMWAY ACT AMENDMENT BILL"; also "GOULBURN AND TUENA TRAMWAY BILL") :—		
RAILWAYS AND, OF NEW SOUTH WALES :—		
Report on, for 1886, laid on Table, 6	6	1
Do. for 1887, laid on Table, 635	6	225
GOVERNMENT :—		
Motion made (<i>Mr. Frank Farnell</i>) for a return of expenditure on construction, giving cost of each line, with amount expended on rolling stock and machinery, 22; Return to Order laid on Table, 174	6	1199
Motion made (<i>Mr. McElhone</i>) for return of correspondence in reference to leasing, 307; Return to Order laid on Table, 369	6	1141
Return respecting, laid on Table, 524	6	1201
BLUE METAL FOR RAILWAYS AND :—		
Motion made (<i>Mr. O'Sullivan</i>) for all tenders, minutes, and papers, relating to the purchase of 3,000 tons, 48; Return to Order laid on Table, 122	6	1109
LAND RESUMED FOR RAILWAY AND, PURPOSES :—		
Motion made (<i>Mr. Schey</i>) for return showing the amount of compensation paid annually for, during the past seven years, giving particulars, 103; Return to Order laid on Table, 267	6	1115
AUTOMATIC ELECTRIC CARS :—		
Correspondence respecting, laid on Table, 373	6	1125
EMPLOYEES :—		
Motion made (<i>Mr. Stephen</i>) for return of particulars of dismissal, and re-employment of, 398.		
IRON AND STEEL RAILWAY AND TRAMWAY MATERIALS :—		
Motion made (<i>Mr. Fletcher</i>) for particulars of purchase of, 479.		
MR. L. C. JENKINS, LATE DRIVER :—		
Correspondence respecting, laid on Table (<i>not printed</i>), 505.		
TRANSIT CHARGES ON MAILS THROUGH FRANCE AND ITALY :—		
Correspondence respecting, laid on Table, 341	4	1111
TRANSIT COMMISSIONERS (See "METROPOLITAN TRANSIT COMMISSIONERS").		

REFERENCES TO THE VOTES AND PROCEEDINGS, VOL. I—13TH PARLIAMENT—SESSION, 1887-8.	PAPERS.	
	VOL.	PAGE.
T		
TRAVELLING EXPENSES (See "DOCKER, JUDGE").		
TRICKETT WILLIAM JOSEPH, ESQ. :— Resignation of, as a Member for Paddington, reported, 249.		
TRUCKS (See "RAILWAYS").		
TRUST ACCOUNTS (See "ROAD TRUST ACCOUNTS.")		
TRUST FUNDS (See "FINANCE.")		
TRUSTEES (See also "PERPETUAL TRUSTEE COMPANY BILL"; also "PERMANENT TRUSTEE COMPANY OF NEW SOUTH WALES BILL"; also "ASSOCIATION CRICKET GROUND.")		
DEVONSHIRE-STREET CEMETERY :— Return showing names of, laid on Table, 263	8	1055
TRUSTEES OF PRESBYTERIAN CEMETERY, MACLEAN (See "PRESBYTERIAN CEMETERY AT MACLEAN").		
"TSINAN," S.S. :— Return respecting Chinese passengers by, laid on Table, 454	2	211
TUENA (See "GOULBURN AND TUENA TRAMWAY BILL.")		
TUGS :— RICHMOND RIVER :— Conditions respecting the employment of, laid on Table, 165	3	1065
STEAM SERVICE :— Motion made (<i>Mr. See</i>) for all letters, tenders, and other documents relating to the calling for and acceptance of tenders for, on various harbours and rivers for 1888, 220; Return to Order laid on Table, 280	3	1053
TULCUMBA (See "ROADS").		
TULLY, MARTIN, JUNIOR (See "CROWN LANDS PURCHASES VALIDATION BILL").		
TUMBERUMBA (See "RAILWAYS").		
TYPHOID FEVER :— Report of Board of Health on, in Sydney and Suburbs from 1876 to 1888 laid on Table, 543	2	231
Report of Board of Health on Treatment of, at the Coast Hospital, laid on Table, 608	2	235
OUTBREAK OF, AT GLENDUART, MORUYA :— Motion made (<i>Mr. Lakeman</i>) for all papers relating to, 519; Return to Order, laid on Table, 578	2	239
U		
UNEMPLOYED (See also "CASUAL LABOUR BUREAU") :— Particulars respecting, laid on Table, 174	8	1307
UNIVERSITY OF SYDNEY :— Amended By-laws, laid on Table, 6, 257 (?)	4	557, 569, 571
Information respecting Examination Fees during 1886-7 laid on Table, 348	4	555
Report of, for 1887 laid on Table, 524	4	547
UPPER MURRAY (See "RAILWAYS").		
USHER (See "BLACK ROD").		
V		
VACANT SEAT (See "ELECTORAL").		
VACCINATION :— Report for 1887, laid on Table, 479	2	229
VALIDATION BILL (See "CROWN LANDS PURCHASES VALIDATION BILL").		
VAUGHN MR. :— MEMBER FOR GRENFELL :— Declared guilty of persistent disorder and removed by the Sergeant-at-Arms from the Chamber, 221.		
"VERNON." (See "NAUTICAL SCHOOL SHIP "VERNON").		
VICTORIAN COAL-MINING COMPANY'S EXTENSION BILL :— Petition presented (<i>Mr. Barbour</i>) for leave to bring in, 181; leave given, presented, and read 1 ^o . 185; referred to Select Committee, 191; Report brought up, 201; read 2 ^o , committed, reported without amendment, and report adopted, 234; read 3 ^o and passed, 236; sent to Council, 237; returned with amendments, amendments agreed to, Message to Council, 410; Assent reported, 419.	2	1201
VINE DISEASES ACT AMENDMENT BILL :— Motion made (<i>Sir Henry Parkes</i>) for leave to bring in, presented, and read 1 ^o , 408; read 2 ^o , committed, reported with amendment, report adopted, 416; read 3 ^o , passed, and sent to Council, 422; returned with amendments, 442; amendments agreed to, Message to Council, 494; Assent reported, 540.		
VITAL STATISTICS (See "STATISTICS").		
VOLUNTEER FORCE REGULATION ACT :— Rules under, of 5th Regiment Scottish Rifles, laid on Table, 6	2	37
Revised Regulations under, laid on Table, 257	2	39
VOLUNTEERS (See also "MILITARY") :— VOLUNTEERS :— FREE RAILWAY PASSES ISSUED BY MILITARY STAFF OFFICE :— Return respecting, during quarter ended 30th June, 1888, laid on Table, 524	6	723
LAND ORDERS :— Motion made (<i>Mr. Crouch</i>) for a Return showing number issued and made use of, specifying the number used in each Land District, 12; Return to Order laid on Table, 168	2	31

REFERENCES TO THE VOTES AND PROCEEDINGS, VOL. I—13TH PARLIAMENT—SESSION, 1887-8.		PAPERS.	
		VOL.	PAGE.
V			
VOTE OF CENSURE :—			
FINANCIAL POLICY OF THE GOVERNMENT :—			
Motion made (<i>Mr. Dibbs</i>) that the Financial Policy of the Government is unsatisfactory, and amendment moved confining the question to such of the financial proposals of the Government as refer to the reduction of the Civil Service salaries, and debate adjourned, 208; debate resumed and further adjourned, 210, 216; debate resumed, <i>disorder</i> arose, and fourteen Members removed from the Chamber, 220, 221; amendment and original motion negatived, 222.			
PURCHASE OF LAND ADJOINING THE AUSTRALASIAN STEAM NAVIGATION COMPANY'S WHARF :—			
Motion made (<i>Mr. Dibbs</i>) that the evidence of the Select Committee discloses injudicious and unsatisfactory administration by the Government, and that the amount paid was in excess of its value, 329.			
THE CHINESE :—			
Motion made (<i>Mr. Dibbs</i>) condemning the Government for late acts in connection with, and amendment moved, 468.			
VOTE OF CHAIRMAN OF SELECT COMMITTEE ON PRIVATE BILLS :—			
Sessional Order passed, 11.			
VOTE OF CREDIT :—			
Message from Governor, recommending, 241 ^(?) , 285, 345, 404, 477, 553.			
VOTES AND PROCEEDINGS (See "ASSEMBLY.")			
W			
WAGES OF EMPLOYEES :—			
DEDUCTIONS FROM, FOR MEDICAL COMFORTS :—			
Motion made (<i>Mr. Walker</i>) for Select Committee to inquire into practice of Contractors, 353; Return to Order, "Patients received into Hospitals from Public Works," referred to; Committee, 462.			
WAGGA WAGGA (See also "CROWN LANDS"; also "RAILWAYS") :—			
LAND OFFICES, ALBURY AND :—			
Motion made (<i>Mr. Day</i>) for all papers, reports, &c., by Board of Inquiry into, 23.			
REMOVAL OF SURVEY OFFICES FROM ALBURY TO :—			
Motion made (<i>Mr. Day</i>) for all reports, minutes, and recommendations with reference to, 41. Return to Order, laid on Table, 476.			
WALGETT (See "RAILWAYS").			
WALKER, MR. :—			
A MEMBER FOR NORTHUMBERLAND :—			
"Named" by Mr. Speaker, in Division; motion made adjudging him guilty of contempt, disorder arising, bars opened, and motion lapsed, 156.			
Declared guilty of persistent disorder, and removed by the Sergeant-at-Arms from the Chamber, 220.			
WALL, MR. :—			
A MEMBER FOR MUDGEES :—			
Declared guilty of persistent disorder, and removed by Sergeant-at-Arms from the Chamber, 221.			
WALLSEND COAL COMPANY (See also "YOUNG WALLSEND COAL COMPANY'S RAILWAY BILL") :—			
Correspondence respecting the case of the Crown v. Wallsend Coal Company, laid on Table, 524... ..			
WANAARING ROAD (See "STOCK").			
WARATAH (See "RAILWAYS").			
WARRANT :—			
Speaker's, issued committing Member to custody of Sergeant-at-Arms, 480.			
WARREN, PROFESSOR (See "BRIDGES").			
WARREN SOUTH RUN (See "CROWN LANDS").			
WATER AND SEWERAGE (See "COUNTRY TOWNS WATER AND SEWERAGE ACT EXTENSION BILL"; also "COUNTRY TOWNS WATER AND SEWERAGE ACT").			
WATER AUGERS :—			
Return of outstanding accounts in connection with, and Diamond Drills, laid on Table, 273.....			
WATER CONSERVATION :—			
LAKE CUDGELLICO AND THE LACHLAN RIVER :—			
Motion made (<i>Mr. Gormly</i>) for construction of works, 560.			
COMMISSION :—			
Motion made (<i>Dr. Ross</i>) for all correspondence, vouchers, &c., relating to expenditure by the recently expired, 155. Return to Order, laid on Table, 565			
WATER SUPPLY (See also "CROWN LANDS"; also "METROPOLITAN WATER AND SEWERAGE ACT AMENDMENT BILL") :—			
Reports of Messrs. Bishop, Whitton, and Bennett, C.Es., on Prospect Dam, laid on Table, 529 ...			
Report of Board appointed to inquire into Kenny Hill and Potts' Hill Reservoirs' Schemes, laid on Table, 547; Plan and tracing in reference to laid on Table (<i>to be appended to the Report</i>), 560			
Letter from F. B. Gipps, C.E., dated 5th July, 1888, to be appended to return, laid on Table (<i>to be appended to Report</i>), 578.			
SYDNEY AND SUBURBS :—			
Return respecting laid on Table, 635			
LISMORE :—			
Notification of resumption of certain land required in connection with construction of works for, laid on Table, 5			
BALRANALD :—			
Notification, under the Country Towns Water and Sewerage Act, authorizing the construction of works for, laid on Table, 6.....			
PUBLIC WATERING PLACES :—			
Return showing cost of maintenance and revenue of, laid on Table, 84			
WESTERN SUBURBS OF SYDNEY AND DISTRICTS NORTH OF PARRAMATTA RIVER :—			
Resumption of land under Lands under Public Purposes Acquisition Act required in connection with, laid on Table, 165.....			

REFERENCES TO THE VOTES AND PROCEEDINGS, VOL. I—13TH PARLIAMENT—SESSION, 1887-8.	PAPERS.	
	VOL.	PAGE.
W		
WATER SUPPLY (continued) :—		
TOWN OF ORANGE :—		
Resumption of land under Public Purposes Acquisition Act required in connection with, laid on Table, 613.....	5	875
WENTWORTH :—		
Notification under Country Towns Water and Sewerage Act, completion of Water Supply Works for, 475.....	5	885
WATSON'S BAY (See "WHARVES").		
WAYS AND MEANS :—		
Committee of, Sessional Order passed, 11.		
Motion made (<i>Mr. Burns</i>) for the House to go into Committee, 174, 295, 346, 409, 430, 481, 501, 554, 561, 627.		
House in Committee, 201 (<i>Financial Statement</i>), 229, 234, 241, 242, 247, 295, 346, 409, 430, 481, 501, 554, 561, 627.		
Resolutions reported, 242, 248, 295, 346, 409, 430, 481, 554, 561, 627.		
Resolutions agreed to, 242, 248, 295, 346, 409, 430, 481, 554, 561, 627.		
Estimates of, for the year 1888, laid on Table, 201, 613.....	3	371, 461
WEBB, FREDERICK WILLIAM (See "CLERK OF ASSEMBLY").		
WEEKLY ABSTRACTS OF PETITIONS :—		
Nos. 1 to 37.....	1	745
WEEKLY REPORTS OF DIVISIONS :—		
Nos. 1 to 22.....	1	657
WEIRS ("See DAMS AND WEIRS REGULATION AND REGISTRATION BILL").		
WELLINGTON (See "RAILWAYS").		
WELLS PUBLIC (See "TANKS AND WELLS").		
WENTWORTH (See "ELECTORAL"; also "BRIDGES"; also "WATER SUPPLY.")		
WENTWORTH ELECTORATE SUBDIVISION BILL :—		
Motion made (<i>Mr. Abbott</i>) for leave to bring in, 40; presented and read 1 ^o , 49; read 2 ^o , committed, reported with amendments, 107; Order of the Day postponed, 113; report adopted, 131; read 3 ^o , passed, and sent to Council, 136; returned with amendments, 210; Order of the Day postponed, 237; Council's amendments agreed to, 243; Assent reported, 250.		
WENTWORTH, WILLIAM CHARLES, PORTRAIT OF THE LATE :—		
CENTENNIAL EXHIBITION, MELBOURNE :—		
Letters from Executive Commissioner asking for loan of pictures in the Parliamentary Buildings, and resolution passed against sending them, 569.		
WERRIL ISAAC, GATEKEEPER, RAILWAY DEPARTMENT :—		
Information respecting compensation to family of, laid on Table, 403.....	6	645
WEST BOTANY (See "ROCKDALE MUNICIPALITY NAMING BILL").		
WEST MAITLAND CATTLE SALE-YARDS BILL :—		
Petition presented (<i>Mr. Bruncker</i>) for leave to bring in, 478; leave given, 493; presented and read 1 ^o , 501; referred to Select Committee, 507; report brought up, 519.....	2	1207
WEST WALLSEND COLLIERY (See "MINING").		
WESTERN SUBURBS (See "WATER SUPPLY"; also "SEWERAGE"; also PARLIAM- MENTARY STANDING COMMITTEE ON PUBLIC WORKS.)		
WHALING ROAD, NORTH SHORE :—		
Motion made (<i>Mr. Levien</i>) for a Select Committee on, 268; leave given for Committee to make visits of inspection, 287.		
Petition presented (<i>Mr. Street</i>) from North Shore Gas Company, praying for leave to appear before the Committee, and prayer granted, 294.....	5	1017
WHARVES (See also "PARLIAMMENTARY STANDING COMMITTEE ON PUBLIC WORKS) :—		
DRUMMOYNE PARK :—		
Motion made (<i>Mr. Carruthers</i>) for all leases, tenders, correspondence, &c., relating to leasing of, : 122; Return to Order laid on Table, 199.....	3	1021
NEAR FREDERICKTON, MACLEAY RIVER :—		
Notification of resumption of land for, laid on Table, 475.....	3	1049
NEAR GHINNY GHINNY :—		
Notification of resumption of land for, laid on Table, 475.....	3	1051
MOAMA :—		
Report upon extension of channel and improvements, laid on Table, 302.....	3	1039
ACCOMMODATION FOR TRAFFIC BETWEEN SYDNEY AND BALMAIN :—		
Petition presented residents and others Western Suburbs in favour of additional, and read by Clerk, 543.....	3	1041
PUBLIC, AT WATSON'S BAY :—		
Motion made (<i>Mr. Neild</i>) for papers relating to leasing of, 585; Return to Order laid on Table, 642.....	3	1043
WHEAT :—		
Despatches respecting Trade between Australia and Barcelona, laid on Table, 335, 475.....	8	1309, 1311
WHITTINGHAM PLATFORM (See "RAILWAYS").		
WHITTON, MR. C. E. :—		
Report of, on Prospect Dam, laid on Table, 529.....	5	849
WILCANNIA (See "BRIDGES").		
WILKINSON'S COMBINATION TRUCK (See "RAILWAYS").		
WILKINSON, W. C., ESQ., M.P. (See "PRINCE ALFRED HOSPITAL").		
WINES (See also "SPIRITS") :—		
PRODUCTION OF :—		
Petition presented from Vinegrowers of New South Wales, in reference to, and suggesting measures for assisting the industry, and read by the Clerk, 635.....	8	1257
WISE, THE HONORABLE BERNHARD RINGROSE, ESQUIRE, M.P. :—		
Motion made (<i>Mr. Dibbs</i>) as privilege, to refer to Committee of Elections and Qualifications whether Mr. Wise, one of the Members for South Sydney, has not, since his election, accepted an office of emolument, having accepted a fee of fifty-five guineas from the Commissioner for Railways, in contravention of the 28th section of the Constitution Act, 53; Report brought up, 55.....	1	903
Resignation of Office of Attorney-General by, 252.		
WITHERS, HENRY (See "TERALBA COAL-MINING RESERVE").		
WOOD PAVING :—		
Return respecting cost of in the City and Suburbs, laid on Table, 420.....	2	289
WOODWARD, FRANCIS, ESQ., M.P. :—		
Leave of absence granted to, 308.		

REFERENCES TO THE VOTES AND PROCEEDINGS, VOL. I—13TH PARLIAMENT—SESSION, 1887-8.	PAPERS.	
	VOL.	PAGE.
W		
WOODSTOCK (See "RAILWAYS").		
WOOL (See also "LIENS ON WOOL BILL").		
WOOL, CARRIAGE ON :— Original tenders for from Railway Station, Redfern, and Darling Harbour, laid on Table (<i>as Exhibits only</i>), 454		
WOOLLOOMOOLOO BAY (See "PARLIAMENTARY STANDING COMMITTEE ON PUBLIC WORKS.")		
WORDS OF HEAT (See "M'ELHONE, JOHN, ESQ., M.P.")		
WORKMEN'S TOOLS :— Return respecting Thefts of, laid on Table, 302.....	8	1297
WORKS, NATIONAL AND LOCAL :— Statement of expenditure on, in the Colony, from 1860 to 1886, laid on Table, 28.....	8	1231
WORKS AND MANUFACTORIES (See "STATISTICS").		
WORKSHOPS (See "RAILWAYS," also "FACTORIES AND WORKSHOPS REGULATION BILL").		
WRITS OF ELECTION (See "ELECTORAL").		
Y		
YASS ROMAN CATHOLIC CHURCH LAND SALE BILL :— Petition presented (<i>Mr. Colls</i>) for leave to bring in, 58 ; leave given, presented, and read 1 ^o , 64 ; referred to Select Committee, 70 ; Report brought up, 99 ; read 2 ^o , committed, reported without amendment, and report adopted, 147 ; read 3 ^o , passed, and sent to Council, 150 ; returned without amendment, 210 ; Assent reported, 239.	2	1215
YATES MR. LEOPOLD, ACTING STIPENDIARY MAGISTRATE :— Information respecting, laid on Table (<i>not printed</i>), 378	2	1215
YOUNG (See "RAILWAYS").		
YOUNG, THE HONORABLE JAMES HENRY, M.P. (See "SPEAKER").		
YOUNG WALLSEND COAL COMPANY'S RAILWAY BILL :— Petition presented (<i>Mr Brunker</i>) for leave to bring in, 613 ; leave given, presented, and read 1 ^o , 619.		

1887-8.

LEGISLATIVE ASSEMBLY.

NEW SOUTH WALES.

LETTERS OF REGISTRATION OF INVENTIONS

UNDER

16 VICTORIA, No. 24;

FOR

1884.

Printed in accordance with Resolution of Legislative Assembly.



SYDNEY : CHARLES POTTER, GOVERNMENT PRINTER.

1888.

[£2]

245—*a*

[860 copies—Approximate Cost of Printing (labour and material), £891 2s. 6d.]

1887-8.

LEGISLATIVE ASSEMBLY.

NEW SOUTH WALES.

LETTERS OF REGISTRATION OF INVENTIONS.

(DESCRIPTIONS, SPECIFICATIONS, &c., ACCOMPANYING APPLICATIONS FOR.)

Printed in accordance with Resolution of Legislative Assembly.

RETURN (in part) to an *Address* of the Honorable the Legislative Assembly of New South Wales, dated 10 May, 1861, A.M., praying that His Excellency the Administrator of the Government would be pleased to cause to be laid upon the Table of this House (in addition to the Return already upon the Table),—

“ (1.) A copy of the Descriptions and Specifications accompanying any
“ applications for Letters of Registration of Inventions under the Act of
“ Council, 16 Victoria, No. 24, together with the date of application for such
“ Letters of Registration, and when granted ; also, copies of the Plans or
“ Sections annexed, and of the Report, in each case.

“ (2.) That His Excellency will cause similar Returns to be laid before
“ Parliament annually.”

(*Mr. Hart.*)

INDEX.

	NAME OF APPLICANT.	DATE OF APPLICATION.	NATURE OF INVENTION.	WHEN GRANTED.	PAGE.
				1884.	
1353	Adolph Herzog	12 Oct., 1883	Improvements in furnaces and flues of and for steam engine boilers.	4 January ...	17
1354	Henry Williams Treloar..	24 Sept., 1883	The nonpareil tree and stump extractor	4 January ...	21
1349	Joseph Carter	20 Oct., 1883	Improvements in machines for concentrating finely divided metalliferous material.	4 January ...	1
1355	Thomas Evans.....	3 Oct., 1883	An improved self-acting spring pad truss	4 January ...	23
1352	Edward Beaufort Cullen..	27 Sept., 1883	Improvements in propellers and in the construction of ships suitable therefor.	4 January ...	13
1351	Frederic Augustus Luckenbach.	27 Sept., 1883	Improvements in the mode of, and machine for, pulverizing ores and other substances.	4 January ...	9
1350	John Lysaght	10 Oct., 1883	An improved machine for the manufacture of wire netting.	4 January ...	5
1358	Colin Mackay, Henry Walden, and Henry North.	1 Oct., 1883	An improved machine for twisting or spinning and reeling wire.	11 January ...	29
1357	George Tolson and John Edwin Tolson.	6 Sept., 1883	A new or improved method of treating material composed of vegetable and animal matter, whereby the vegetable matter is extracted and the animal matter dyed; also, for apparatus employed therein.	11 January ...	27
1362	William Woodcock and Edward West.	17 Sept., 1883	Improved contrivances for barbing wire by hand.	11 January ...	41
1356	William Adam Dixon and Robert Saddington.	9 Oct., 1883	For making walls constructed of stone, brick, cement, and similar materials damp proof.	11 January ...	25
1359	Stephen Osborne and Andrew Thomas.	6 Oct., 1883	An improved method of extracting gold and silver from certain of their ores, and utilising some of the other products of the process.	12 January ...	33
1366	Potter's Patent Wool-scouring Company of New Zealand (Limited)	17 Oct., 1883	Improved apparatus for cleansing and scouring wool.	16 January ...	55
1367	Norman Selfe	7 Nov., 1883	Improvements in the machinery of elevators ...	16 January ...	59
1363	Wilhelm Fischer.....	1 Oct., 1883	Improvements in pianofortes	16 January ...	43
1365	Horatio Sutherland	3 Nov., 1883	An improved quartz-crusher or mill, to be used for crushing and pulverising quartz and other minerals and materials.	16 January ...	51
1361	Albert Daniel Ancel and Jean Marie Antonin Thiollier.	15 Nov., 1883	A process of, and apparatus for, extracting metals from their ores.	16 January ...	35
1364	James Morgan Blackman	19 Nov., 1883	Improvements in ventilating and exhaust fans, and in the application thereof for drying malt and other materials.	16 January ...	47
1369	James Brookhouse Preston and James Shepherd.	8 Nov., 1883	Improvements in circular saws.	22 January ...	67
1372	Joseph Husband and William Wright.	25 June, 1883	Improvements in machinery for sinking shafts, and for tunnelling under water, or through treacherous ground.	22 January ...	77
1373	The Acme Horse-shoe Nail Company.	21 April, 1881	Improvements in machinery or apparatus for the manufacture of horse-shoe nails.	22 January ...	81
1375	Abraham Batterham	26 Nov., 1883	Improvements in the method of, and apparatus for, entrapping certain wild animals.	22 January ...	91
1370	The Consolidated Electric Company (Limited).	30 Aug., 1883	Improvements in or connected with secondary batteries.	22 January ...	69
1371	The Consolidated Electric Company (Limited).	30 Aug., 1883	Improvements in electric current measuring and governing apparatus.	22 January ...	73
1374	Paul Henri Picard-Goulet, fils.	15 Nov., 1883	A new or improved process for separating wool from sheepskins in the fresh state.	22 January ...	87
1368	Henry Hudson, William Hudson, Robert Hudson, and Ambrose Thornley.	12 Nov., 1883	The Australian combination railway and tram truck for goods, cattle, or sheep.	22 January ...	63

No.	NAME OF APPLICANT.	DATE OF APPLICATION.	NATURE OF INVENTION.	WHEN GRANTED.	PAGE.
				1884.	
1377	Sydney Wroughton Fulton	1 Dec., 1883	An improved portable wire strainer.	6 February...	95
1378	Henry Timken	1 Dec., 1883	An improved spring for vehicles.	6 February...	97
1381	Horace Stevens	17 Nov., 1883	An improved method of automatically opening or closing valves or cocks at any given period of time.	6 February...	105
1380	Gaston Planté, Thomas Parker, and Paul Bedford Elwell.	29 Nov., 1883	Improvements in preparing the sheet lead electrodes of secondary batteries with a view to their rapid "formation."	6 February...	103
1382	Edwin John Dark and Frank Thomas Bury.	1 Dec., 1883	An improved sheep and cattle label and improved pliers for fastening them in position.	6 February..	107
1383	Joseph Thomas Burton Gibbs.	12 Nov., 1883	The Gibbs-Barrett automatic multicolor printing apparatus.	6 February...	109
1379	John Brown.....	14 Nov., 1883	Improvements in couplings for tram and railway rolling stock.	6 February...	99
1384	William Coppin & Emelie Alexander.	15 Aug., 1883	Improvements in the construction of ships	11 February...	113
1385	William Snead	1 Dec., 1883	Improvements in wind-mills	13 February...	115
1386	Stanley Charles Cuthbert Currie.	14 Dec., 1883	Improvements in the construction and arrangement of the cores and armatures and other parts of electro-magnets.	13 February...	117
1387	Gustave Sueur.....	29 Oct., 1883	An improved registering device	13 February...	121
1389	Edward B. Orne.....	8 Dec., 1883	Improvements in and relating to wheels and axles for railway vehicles.	13 February...	125
1388	William Humble Johnson	15 Dec., 1883	Improvements in hydraulic lifts	13 February...	123
1392	Richard Oakley	14 Dec., 1883	Improved appliances for ventilating churches, schools, and other buildings.	14 February...	135
1391	Thomas Robert Raney Ashton.	20 Dec., 1883	Improvements in machines for grubbing or extracting roots and trees.	14 February...	131
1390	Wilton Hack	19 Dec., 1883	Improved stump extractor.....	14 February..	129
1395	Alfred Upton Alcock.....	29 Dec., 1883	Improvements in electrical apparatus for registering numbers, such as for billiard marking.	18 February...	141
1394	Robert Punshon and Robert Robinson Vizer.	31 Dec., 1883	An improved method of, and apparatus for, utilising an explosive compound for blasting or other purposes.	18 February...	139
1396	Elizabeth Barnston Parnell.	2 Jan., 1884	E. B. Parnell's pyrites process, No. 2	18 February...	145
1393	Isaac Roff, Robert Spencer Eastham, and Joshua Alexander Kay.	28 Dec., 1883	A pressure regulator	18 February...	137
1401	Martin Lyons	11 Jan., 1884	An improved method of constructing post and rail fencing.	11 March	149
1404	Bernhard Samuelson	23 Jan., 1884	Improvements in harvesting machines	18 March	153
1403	George Downie	28 Jan., 1884	An improvement in the prevention and removal of scale in steam boilers.	18 March	151
1405	Thomas Constantine Fawcett.	23 Jan., 1884	Improvements in apparatus for the prevention of explosives and other derangements in steam boilers.	18 March	155
1408	Joseph Husband.....	31 Jan., 1884	Improvements in apparatus for removing earth and other obstructions within the grooves of tram rails.	16 April	163
1411	William Wilkinson	19 Jan., 1884	Improvements in wool-washing machines	16 April	173
1413	Thomas Douglas Kyle ...	6 Feb., 1884	Improvements in apparatus for making artificial ice in blocks or slabs.	16 April	179
1406	Robert Henry Firth	31 Jan., 1884	Improvements in apparatus for arresting sparks from steam engines.	16 April	157
1415	Ernest Boutard	25 Feb., 1884	Improvements in apparatus for reversing the motion of steam and other engines.	16 April	191
1409	Richard Pickup Park ...	18 Feb., 1884	Improvements in rotary engines	16 April	165
1410	William Henry Masters and Thomas Theophilus Draper.	25 Feb., 1884	Improvements in telephone exchange apparatus	16 April	169

INDEX.

No.	NAME OF APPLICANT.	DATE OF APPLICATION.	NATURE OF INVENTION.	WHEN GRANTED.	PAGE.
				1884.	
1416	George Fred Shaver	9 Feb., 1884	Improvements in mechanical telephone apparatus, chiefly designed for a central office or exchange system.	16 April	195
1412	George Westinghouse ...	30 Jan., 1884	An improvement in the connection of pipes for communicating fluid pressure to work brakes on railway trains.	16 April	175
1407	William Hooker	9 Feb., 1884	Improvements in material and in apparatus for enriching illuminating gas.	17 April	159
1414	Cassins Clay Palmer	28 Jan., 1884	Improvements in refrigerator cars	17 April	183
1421	Thomas Rowland Jordan and John Needham Longden.	3 Mar., 1884	An improved method or process and apparatus for extracting metals from their ores and concentrating heavy materials.	29 April	199
1422	Thomas Rowland Jordan	3 Mar., 1884	Improvements in machinery or apparatus for treating ores, chiefly for the extraction of precious metal therefrom.	29 April	201
1425	William Edward Wilson	27 Aug., 1883	An improved locomotive brake	9 May.....	209
1427	John Forsyth Johnstone	15 Mar., 1884	Improvements in drying apparatus, applicable especially for drying all kinds of waste, animal, fish, or other matter.	9 May.....	217
1426	John James Royle	18 Mar., 1884	Improvements in or applicable to gas-fittings, reading-lamps, and shades for gas and other lights, and for supplying gas to stoves, and for other purposes.	9 May.....	213
1424	Thomas Otis Potter	14 Mar., 1884	Improvements in suspenders or braces	9 May.....	205
1428	Duncan Stewart	15 Mar., 1884	Improvements in sugar-cane mills	9 May	221
1429	Solomon De Beer and Louis Henry Hart.	17 Jan., 1884	A wedge-shaped cigarette	9 May	225
1430	John Clark	Improvements in extracting cobalt, nickel, and manganese from their ores.	27 May	229
1431	William Bartholomew ...	15 Mar., 1884	Improvements in flushing tanks or vessels for receiving water or liquid, and, when full, automatically discharging it.	27 May	231
1433	John Glas Sandeman and Percival Everitt.	3 April, 1884	Improved apparatus for delivering prepaid goods.	27 May	237
1434	Louis Adolphe Fortin-Herman.	15 Mar., 1884	Improvements in electric cables or conductors	27 May	241
1432	George Jackson and Henry Upton Alcock.	31 Mar., 1884	Improvements in fret-saw machinery, a part of which is applicable to other machinery.	27 May	235
1436	Robert Wilcox	7 April, 1884	Improvements in steamship propellers, and in machinery for driving same.	16 June.....	243
1440	Conrad Icke.....	17 Mar., 1884	Icke's cupola oven or furnace for the treatment of pyrites and other ores or substances.	23 June.....	251
1444	Charles Francis Brush ...	15 April, 1884	Improvements in the process or method of, and in apparatus for "forming" or preparing plates or elements for use in secondary batteries.	23 June.....	263
1443	Moritz Honigmann	23 April, 1884	An improved method of generating heat, and an improved apparatus for carrying such method into effect.	23 June.....	259
1442	Stanley Charles Cuthbert Currie and Illius Augustus Timmis.	30 April, 1884	Improvements in the means for working and locking and interlocking railway signals and points.	23 June.....	255
1439	Edward Spencer.....	12 May, 1884	Improvements in the treatment of finely divided auriferous material for the extraction of gold and quicksilver, the residual product being a useful pigment.	23 June.....	247
1445	Joshua Alexander Kay, Nathaniel Buchanan, and Alexander Robert Wallis.	16 April, 1884	Improvements in machinery for tying knots.....	23 June.....	267
1446	John Clark	4 April, 1884	Improvements in extracting nickel from its ores	23 June.....	269
1447	Frank Mack	24 April, 1884	Improvements in the construction of sheep and cattle trucks.	23 June.....	273

No.	NAME OF APPLICANT.	DATE OF APPLICATION.	NATURE OF INVENTION.	WHEN GRANTED.	PAGE.
				1884.	
1441	The Roberts Patent Sanitary Process Company, Limited.	7 May, 1884	Filtration and separation of sewage	23 June.....	253
1449	Robert Newton Helme ...	1 May, 1884	Pneumatic ventilator	7 July	277
1453	John Dye La Monte	15 May, 1884	An improved process of treating finely-divided auriferous material prior to smelting it.	7 July	281
1452	David Moritz	16 May, 1884	Window supporter and lock	7 July ..	279
1455	William Wright	7 April, 1884	An improved coupling for the rods of those boring machines whose rods have a jumping motion.	8 July	285
1454	William Jones.....	12 May, 1884	Never-failing hair restorer	8 July	283
1457	John Currie Johnson	9 April, 1884	An improved process of, and machine for, cutting rags.	11 July	291
1456	Hippolyte Leplay	15 May, 1884	Process and apparatus for baryta or strontia treatment of saccharine liquors, and for production and recovery of these reagents.	11 July	287
1458	Albert Thomas King and John Arthur Grant.	15 May, 1884	An improved method of, and apparatus for, reducing the temperature, and supplying pure air within public halls, churches, schools, dwelling-houses, and other buildings.	15 July	293
1463	Harry Wood Kerle	23 May, 1884	Improvements in hydraulic elevators	15 July	207
1460	Jesse Spring	29 May, 1884	Improvements in the making of wheels for carriages, buggies, drays, carts, and other vehicles, dispensing with the necessity of cutting and shutting the tyres of such wheels.	15 July	299
1459	Franz Kindermann	7 May, 1884	Kindermann's improved process for coupling railway carriages.	15 July	297
1464	Richard Matthews Ruck and Edwyn Jones.	15 May, 1884	Improvements in apparatus for maintaining torpedoes, submarine mines, buoys, floating breakwaters, floating piers, or other floating bodies at a constant or nearly constant depth below the surface of the water.	15 July	311
1462	Joseph Oppenheimer	29 May, 1884	Improvements in telegraph posts.....	15 July	303
1461	William Edward Barry...	31 May, 1884	An improvement in amalgamators	15 July	301
1465	John Hopkinson	1 Dec., 1883	Improvements in apparatus for measuring electricity.	16 July	315
1466	Thomas Swallow, Frederick Thomas Derham, and William Henry Swallow.	12 May, 1884	An improved process of preparing dough for manufacture into biscuits or cakes.	24 July	319
1469	Edward Probert.....	9 June, 1884	Improvements in ore smelting-furnaces	29 July	327
1468	Henry Moon	11 June, 1884	Improvements in amalgamating machines	29 July.....	323
1467	Thomas Midelton and Thomas Sellwood Huntley.	11 June, 1884	Improvements in mechanical appliances or apparatus for coaling locomotive engines and removing ashes from engine pits, locomotive depôts, and other places.	29 July.....	321
1472	George Phillips & Thomas Henderson Annett.	28 May, 1884	Phillips and Annett's transverse iron sleeper ...	30 July.....	335
1471	William Hooker.....	12 May, 1884	Omega gas-making apparatus	30 July.....	333
1470	Joseph Carter	31 May, 1884	Improvements in machines for concentrating finely-divided auriferous material.	30 July.....	331
1474	George Edwards	11 June, 1884	The self-acting wire fence	6 August ...	339
1473	Richard Oakley	17 June, 1884	A combined deflecting and injecting exhaust roof ventilator and chimney cowl.	6 August ...	337
1476	Richard Oakley	17 June, 1884	An improved ventilating stove.....	6 August ...	345
1475	Samuel Henry Stockton..	19 June, 1884	A preparation for preserving piles, and any woodwork immersed, or to be immersed, in salt water, from the ravages of worms, and other marine animals, and the mode of its application.	6 August ...	343
1485	William M'Laughlin	7 July, 1884.	An improved hedge-trimmer, land clearer, and harvesting machine.	12 August ...	359

No.	NAME OF APPLICANT.	DATE OF APPLICATION.	NATURE OF INVENTION.	WHEN GRANTED.	PAGE.
				1884.	
1484	Thomas Forrest Cumming	14 July, 1884.	Improvements in and connected with the arrangements of sheep and cattle troughs in relation to dams or tanks.	21 August ...	357
1483	Samuel Rupert Wilson ...	30 June, 1884	Improvements in earth excavators	21 August ...	353
1486	Charles Ashburnham Floyd	2 July, 1884	An improvement in hansom cabs and similar vehicles.	21 August ...	361
1482	Norman Selfe	19 Feb., 1884	Improvements in hydraulic elevators	21 August ...	349
1481	Norman Selfe	19 June, 1884	Improvements in, and for boring in the earth ...	21 August ...	347
1490	Carson Woods.....	2 July, 1884	Improvements in sleeping cars	29 August ...	371
1487	Joshua Barker Carter ...	14 July, 1884	An improved nose-bag for horses.....	29 August ...	363
1491	Henry Renner Cassell ...	30 April, 1884	An improved process and apparatus for separating and treating metals, and extracting them from ores, matter, or all other substances containing them by means of electrolysis, part of which invention is also applicable to other purposes.	29 August ...	373
1488	William Creed	23 June, 1884	An improved machine, convertible into a wire-strainer or auger.	29 August ...	365
1489	John Brown and Thomas Midelton.	7 July, 1884	Improvements in bogies, parts of which are applicable to other undergear for railway and tramway rolling stock.	29 August ...	367
1493	Alexander Watkins	9 July, 1884	Improvements in sewing machines and in spring motors for driving the same.	6 September	389
1492	William Plenderleith Hope.	2 July, 1884	Improvements in and relating to the construction of tramways, and in apparatus for facilitating the haulage of vehicles thereon by means of cables or ropes.	6 September	379
1494	John Rowland Dacey ...	8 July, 1884	Improvements in machines for grubbing or extracting roots and trees.	6 September	303
1496	Henri Herrenschmidt, Marmaduke Constable, Francis Lord, and David Wilson.	16 July, 1884	Improvements in the extraction of cobalt and manganese from their ores, and of nickel from its ores, when such ores are found in a similar condition to those of New Caledonia.	13 September	397
1497	George Summerton	17 July, 1884	Improvements in self-adjusting mill stone irons	18 September	399
1500	James Milne	An improved machine for making clips for fastening wire to their supports.	13 September	411
1501	James Morrow	25 July, 1884	Improvements in harvesting machines	13 September	415
1498	Dan. Rylands	25 July, 1884	Improvements in internally stoppered bottles and in the manufacture of such bottles.	13 September	403
1499	John Fuller Shallis and Thomas Cooper John Thomas.	17 July, 1884	Improvements in lamps or apparatus for lighting railway carriages or for other purposes.	13 September	407
1495	Jason Irving	26 Aug., 1884	Improvements in the manufacture of artificial fuel.	13 September	395
1503	Karl Luckas Blanck	24 July, 1884	Blanck's single and double arm economical reversible rotary engine.	16 September	419
1506	William M'Lean.....	1 Aug., 1884	An improved press, chiefly for the purpose of pressing hay and straw.	22 September	425
1508	Thomas Seale and Franz Carl Guillaume.	25 Feb., 1884	Improvements in wire cables for haulage and like purposes.	22 September	429
1507	James Morrow	9 Aug., 1884	Improved mechanism for supporting the front end of stripping and harvesting machines.	22 September	427
1505	Eugene Etève and Jean André de Braam.	30 July, 1884	Improvements in hydro-carburetted air engines	22 September	421
1512	William Richard Lester..	2 Aug., 1884	Improvements in astragals or glazing bars for holding and securing glass for roof lights and windows.	26 September	441
1511	John Perkins Jackson ...	11 Aug., 1884	Improvements in appliances for filtering water or other liquids.	26 September	439
1509	Joseph Walker.....	7 Aug., 1884	An improved fire bar.....	26 September	433
1510	Price Williams.....	4 Aug., 1884	An improved apparatus for cleaning dams, tanks, and other pools of water, natural or artificial.	23 September	435

No.	NAME OF APPLICANT.	DATE OF APPLICATION.	NATURE OF INVENTION.	WHEN GRANTED.	PAGE.
				1884.	
1513	John Alexander M'Donald	12 Aug., 1884	Improvements in expansion rollers, entitled— M'Donald's expansion rollers.	6 October ...	443
1517	John Forsyth Johnstone..	25 Aug., 1884	Improvements in apparatus for drying waste animal matters, fish, and other materials; applicable also to the concentration of liquids.	14 October ...	447
1519	John Eales, junior	1 Sept., 1884	Eales' maize husker and sheller	17 October ...	451
1522	Charles Osborne Ralph Walker.	30 July, 1884	An improved wire strainer	22 October ...	459
1521	Arthur Henderson Robin- son.	21 July, 1884	Improvements in apparatus or machines for boring the ground for water or other purposes.	22 October ...	453
1524	Edward George Grace.....	1 Aug., 1884	The magic carpet and wool cleaner	23 September	465
1528	Robert Archibald White, Arthur Lucas Harrold, and Walter Frampton.	12 Sept., 1884	Improvements in interlocking apparatus	23 September	475
1526	John Walls	11 Sept., 1884	Improvements in machinery for uprooting stumps and trees.	23 September	469
1527	William Morton Steven- son.	11 Sept., 1884	An improved ticket holder.....	23 September	473
1525	George Boulton Brown Elliott and Benjamin Poulton.	16 Sept., 1884	An improved portable floating apparatus for sluicing alluvial earths.	23 September	467
1523	John Berry	30 Aug., 1884	A process called "The Berrygraph," for copying writing, plans, drawings, &c.	23 September	463
1529	Michael Cock	18 Sept., 1884	An improved coating for explosive compounds and cartridges.	15 November	479
1530	William Thompson and Mary Ann Edwards.	1 Oct., 1884	An improved tip ballast waggon.....	15 November	481
1531	Thomas Gillespie	10 Sept., 1884	Improvements in blast furnaces	15 November	485
1534	George Burnell.....	8 Oct., 1884	Improvements in machinery for drying wool or other substances.	18 November	493
1533	Frederick York Wolseley and Richard Pickup Park.	8 Oct., 1884	Improvements in apparatus for washing sheep...	18 November	491
1532	James Hornsby, Frederick Charles Southwell, and John Innocent.	2 Oct., 1884	Improvements in cradles for receiving and delivering cut crop from harvesting machines.	18 November	487
1536	Henri Herrenschildt ...	15 Aug., 1884	Improvements in the extraction of cobalt, nickel, and manganese from their ores.	1 December	495
1537	Alfred Robb and William Stokes.	8 Oct., 1884	The cup-headed self-adjusting wire roofing nail, requiring no washer.	1 December	497
1538	Charles Frederick Amos and Henry Wilson Ringrose Smith.	9 Oct., 1884	Improvements in double action pumps	3 December	499
1542	Frederick York Wolseley and Richard Pickup Park.	23 Oct., 1884	Improvements in flexible driving gear	13 December	517
1540	Adam Miller	20 Oct., 1884	Amalgamating apparatus	13 December	509
1541	Hugh Thomas Smith.....	13 Oct., 1884	Improvements in vertical revolving stands, suit- able for exhibiting wares and other articles.	13 December	513
1539	James Gresham	26 Sept., 1884	Improvements in or applicable to simple and automatic vacuum brakes.	13 December	501
1545	Josiah Vincent Lavers ...	24 Oct., 1884	Improvements in the use of chloride of lime for the purposes of disinfection and deodorisation.	17 December	531
1544	Edward Joseph Douglas ..	3 Nov., 1884	An improved apparatus for heating water.....	17 December	527
1547	Thomas Alderson and Launcelot Alderson.	24 Oct., 1884	Improvements in the method of tanning, baiting, sumaching, and washing hides, sides, and skins of all descriptions by means of a paddle- wheel or drum.	17 December	535
1543	Lewis Miller	29 Aug., 1884	Improvements in reaping and binding machines	17 December	519
1546	Charles Carroll Gilman...	23 Oct., 1884	An improved composition of materials, called "Terra-cotta Timber."	17 December	533

No.	NAME OF APPLICANT.	DATE OF APPLICATION.	NATURE OF INVENTION.	WHEN GRANTED.	PAGE.
				1884.	
1549	Camfield Baker	30 Oct., 1884	For making relief blocks for printing by a photographic engraving process.	22 December	541
1548	William Harper, Robert Harper, and John Harper.	3 Nov., 1884	An improvement in packages for tea and other purposes.	22 December	537
1550	Henry Hudson and Norman Selfe.	21 July, 1884	Improvements in street railways.....	22 December	543
1557	William John M'Ilwraith	18 Aug., 1884	A self-acting cinder-sifting ash closet.....	30 December	563
1551	Joseph Duke Mackenzie and William Atchison.	6 Oct., 1884	Improvements in and relating to the glazing of roofs and other structures.	30 December	547
1560	George Parkins	25 Sept., 1884	A driving, dropping, and planting plough combined.	30 December	569
1556	Thomas Clarke Jenkins ..	27 Oct., 1884	An improved scoring or registering machine.....	30 December	559
1553	John B. Gafford	27 Oct., 1884	The improved furnace for smelting ores	30 December	555
1555	John B. Gafford	27 Oct., 1884	The improved roasting furnace.....	30 December	557
1552	John Kirkaldy ..	3 Nov., 1884	Improvements in surface condensers and heaters, and apparatus for supplying heated feed-water to the boilers of steam engines.	30 December	551
1559	Adam Miller	3 Nov., 1884	Apparatus for ventilating railway carriages or other rapidly moving vehicles.	30 December	567
1558	George Taylor and Frederick Reid.	20 Nov., 1884	Excelsior potato plough.....	30 December	565



A.D. 1884, 4th January. No. 1349.

MACHINES FOR CONSTRUCTING FINELY-DIVIDED METALLIFEROUS MATERIAL.

LETTERS OF REGISTRATION to Joseph Carter, for Improvements in Machines for Concentrating Finely-divided Metalliferous Material.

[Registered on the 4th day of January, 1884, in pursuance of the Act 16 Vic. No. 24.]

BY HIS EXCELLENCY THE RIGHT HONORABLE SIR AUGUSTUS WILLIAM FREDERICK SPENCER LOFTUS (commonly called LORD AUGUSTUS LOFTUS), Knight Grand Cross of the Most Honorable Order of the Bath, a Member of Her Majesty's Most Honorable Privy Council, Governor and Commander-in-Chief of the Colony of New South Wales and its Dependencies.

TO ALL TO WHOM THESE PRESENTS SHALL COME, greeting :

WHEREAS JOSEPH CARTER, of Goulburn, in the Colony of New South Wales, engineer, hath by his Petition humbly represented to me that he is the author or designer of a certain invention or improvement in manufactures, that is to say, of an invention entitled "Improvements in Machines for Concentrating Finely-divided Metalliferous Material," which is more particularly described in the specification and the sheet of drawings which are hereunto annexed ; and that he, the said Petitioner, hath deposited with the Honorable the Treasurer of the said Colony of New South Wales the sum of Twenty Pounds sterling, for defraying the expense of granting these Letters of Registration, as required by the Act of Council, sixteenth Victoria, number twenty-four ; and hath humbly prayed that I would be pleased to grant Letters of Registration, whereby the exclusive enjoyment and advantage of the said invention or improvement might be secured to him for a period of fourteen years : And I, being willing to give encouragement to all inventions and improvements in the arts or manufactures which may be for the public good, and having received a report favourable to the prayer of the said Petition, from competent persons appointed by me to examine and consider the matters stated therein and to report thereon for my information, am pleased, with the advice of the Executive Council, and in exercise of the power and authority given to me by the said Act of Council, to grant, and do by these Letters of Registration grant unto the said Joseph Carter, his executors, administrators, and assigns, the exclusive enjoyment and advantage of the said invention or improvement, for and during the term of fourteen years from the date hereof ; to have, hold, and exercise unto the said Joseph Carter, his executors, administrators, and assigns, the exclusive enjoyment and advantage thereof, for and during and unto the full end and term of fourteen years from the date of these presents next and immediately ensuing, and fully to be complete and ended : Provided always, that if the said Joseph Carter shall not, within three days after the granting of these Letters of Registration, register the same in the proper office in the Supreme Court, at Sydney, in the said Colony of New South Wales, then these Letters of Registration, and all advantages whatsoever hereby granted, shall cease and become void.

In witness whereof, I have hereunto set my sign manual, and have caused the present Letters of Registration to be sealed with the seal of the said Colony of New South Wales, at Government House, Sydney, in New South Wales, this fourth day of January, in the year of our Lord one thousand eight hundred and eighty-four.

[L.S.]

AUGUSTUS LOFTUS.

Machines for Concentrating Finely-divided Metalliferous Material.

SPECIFICATION of JOSEPH CARTER, of Goulburn, in the Colony of New South Wales, engineer, for an invention entitled "Improvements in machines for concentrating finely-divided metalliferous material."

My invention has been designed in order to produce a light, handy, and easily constructed machine for concentrating finely-divided metalliferous material in a dry state, and, with a slight and easily made change, concentrating such material with the aid of water.

My improvements consist, first, in the combination and arrangement of parts (some of which are well known) which make up my improved concentrating machine; and, secondly, in a novel construction and combination of some of its parts, which are hereinafter particularly set forth and specifically claimed.

My improved machine for concentrating finely-divided metalliferous material consists of two main parts—a revolving screen or sieve and an inclined concentrating bed or surface, having a to-and-fro motion across the line of travel of the material. The latter motion is communicated from a wheel of novel construction upon the main shaft, which revolves the screen or sieve. The inclined concentrating surface is carried by a moving frame, which I call a "cradle," and its inclination is adjustable. When the material to be concentrated is in a dry state the said inclined bed or surface consists of woollen material spread upon a flat surface, over which is firmly fixed a frame forming pockets or angles upon such woollen material, in which the heavier particles of the metalliferous material are caught and retained. When the material is to be concentrated with the aid of water the above-described inclined bed or surface is removed, and a sheet of metal, preferably galvanized iron, or wood, or other material, on which curved bars, to form pockets, are soldered or otherwise attached, is substituted therefor.

But in order that my invention may be clearly understood, I will now describe the same with reference to my drawings, in which fig. 1 is a side elevation, partly in section, of my improved machine for concentrating metalliferous material, adapted for use when such material is in a dry state; and figure 2 is an end view of the same. The other figures are details of various parts, and will be hereinafter referred to. A is a revolving screen or sieve; B the screenings receptacle; C the concentrating surface; D the cradle; E the main shaft; and F the framing. Screen A is formed of wire gauze or wire worked on frame of screen A¹, preferably $\frac{1}{4}$ or $\frac{3}{8}$ inch gauge, carried by angle-iron rings or frames A², and having straps A³ upon its outside (see figure 3); A⁴ A⁵ are its bosses or centres upon main shaft E; A⁶ is discharge end of screen; B¹ is adjustable opening in receptacle B, and B² its lever and handle; B³ is tailings shoot; C¹ is flat surface in this case, a plain board (see figure 4) over which a blanket is spread and kept in place by frame C² (see figure 5), the cross or stop pieces C³ forming angles or pockets C⁴. Board C¹ is carried by frame C⁵ and C⁷, supported from cradle D by fixed standard C⁶ and adjustable support C⁷; C⁸ are cross-bars of this frame; D¹ are cross-bars held in bearings attached to cradle D; D² are rollers that the rods D¹ that carry the cradle work on, and on which the cradle D slides; D³ are cross-frames of cradle and D⁴ centre pins, which can be raised to alter travel of cradle; E¹ is, in this case, a handwheel; E² an eccentric to work a pump to supply tank I; E³ is a wheel, preferably of wrought or malleable iron, having an indented curved circumference, and to which is bolted annulus E⁴, having an indented inner periphery corresponding to the circumference of the wheel, so as to form a cam groove E⁵ (as shown most plainly in figure 1); E⁶ is friction roller, and E⁷ is connecting rod therefrom to crank G¹ on spindle G; G² G³ are forked levers which receive centre pins D⁴ in their forks; H is receiving hopper, I is a water-tank, I¹ a water-pipe, and I² frame for said tank.

Figures 6 and 7 show respectively plan and cross-section of the inclined bed or surface for concentrating metalliferous material with the aid of water. J is a sheet of galvanized iron turned up at its sides, J¹ curved bars soldered thereto, so as to form pockets J².

The mode of operation is as follows:—

The finely-divided metalliferous material is supplied to hopper H, from whence it falls into screen A, which is revolved by means of handwheel E¹, the screenings falling into receptacle B, while the particles, whose bulk will not permit them to pass through the gauze A¹, make their way to discharge and A⁶ and fall into tailings shoot B³, but in their passage meet with obstructions formed by one side of the angle-iron rings or frames A², which thus become riffles or stops to the flow of the material from end to end of the screen, and serve to break up and keep under treatment in the screen any light clotted lumps. From receptacle B the screenings pass through regulated opening B¹ on to the inclined concentrating surface C, the angle at which said surface stands being regulated beforehand by adjustable support C⁷. The cam groove E⁵, in which E³ raises and lowers roller E⁶, and by connecting rod E⁷, crank G¹, spindle G, and forked lever G², communicates motion to the cradle D, which moves the inclined concentrating surface C to and fro across on the rollers D² on cross-bars D¹, and this shakes the lighter particles of the material forward, leaving the heavier and more valuable particles in the pockets or angles C⁴, from which they may be removed at pleasure, and the smallest and heaviest particles will cling to the blanket or woollen surface, from which they may be shaken on its removal.

When the material is to be concentrated by the aid of water the inclined bed or surface C is removed, and that marked J¹ and J² substituted, and water supplied from tank I, with the material in the hopper H along top of screen A. The operation is then in all respects similar to that just before described with reference to concentrating dry material, save that the heavier and more valuable particles are retained in pockets J², which take the place of pockets C⁴.

The machine may be mounted upon wheels and drawn the same as an ordinary cart, and will then serve to transport the ordinary tools of a miner as well. It need not necessarily be operated by manual labour, but may be driven by horse, steam, or other convenient power.

Having thus particularly described and ascertained my said invention, I would have it understood that I do not claim the well-known mechanical contrivances which are necessarily used in my machine as of my invention, but that I only claim as my improvements in machines for concentrating finely-divided metalliferous material,—

1st—The combination and arrangement of parts forming my improved concentrating machine, substantially as herein described and explained, and as illustrated in my drawings.

2nd—The peculiar form and construction of the wheel E³, annulus E⁴, and cam groove E⁵, substantially as herein described and explained, and as illustrated in my drawings.

3rd.

Machines for Concentrating Finely-divided Metalliferous Material.

3rd. The combination and arrangement of parts marked D, D¹, D², D³, and D⁴, and any motion giving contrivances with the parts marked C¹, C², and C³, and the parts marked C, C¹, C², C³, and C⁴ (or the alternative parts marked J, J¹, and J²), substantially as herein described and explained, and as illustrated in my drawings.

JOSEPH CARTER.

19 October, 1883.

This is the specification referred to in the annexed Letters of Registration granted to Joseph Carter, the 4th day of January, A.D. 1884.

AUGUSTUS LOFTUS.

REPORT.

Sir,

Sydney, 27 October, 1883.

The petition of Mr. Joseph Carter for Letters of Registration for an invention entitled "Improvements in Machines for Concentrating Finely-divided Metalliferous Material," having been referred to us, we have examined the specification and drawings accompanying the same, and have the honor to report that we see no objection to the granting of the petition, in accordance with the specification and claim.

We have, &c.,
J. SMITH.
A. LEIBIUS.

The Under Secretary of Justice.

[Drawings—one sheet.]

JOSEPH CARTER'S PATENT

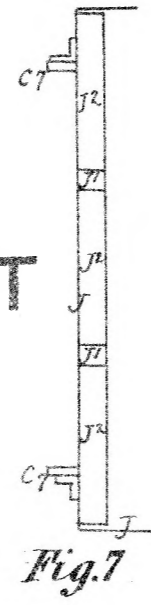


Fig. 7

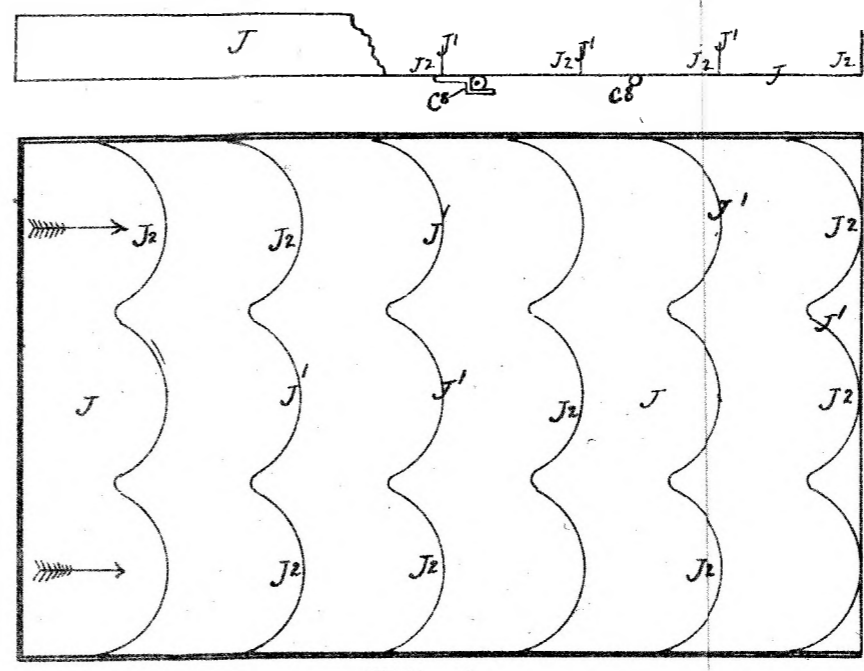


Fig. 6. End View

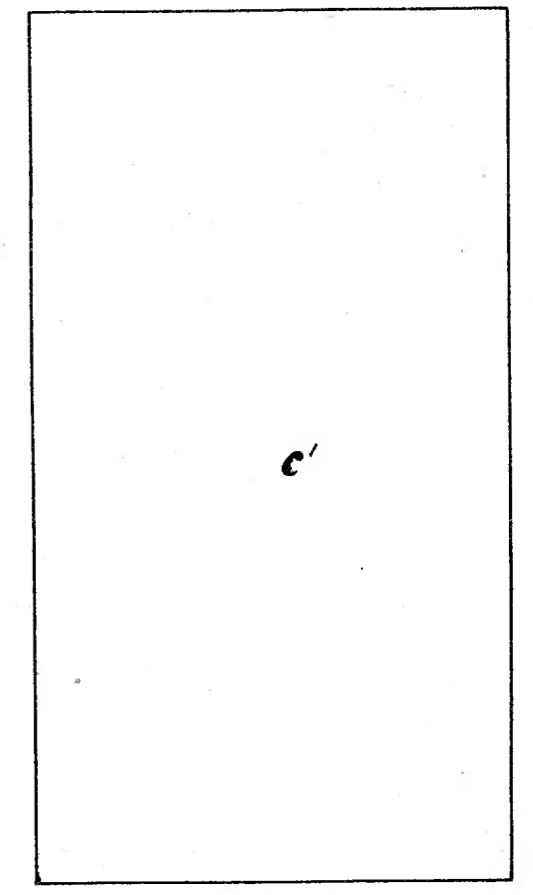


Fig. 4.

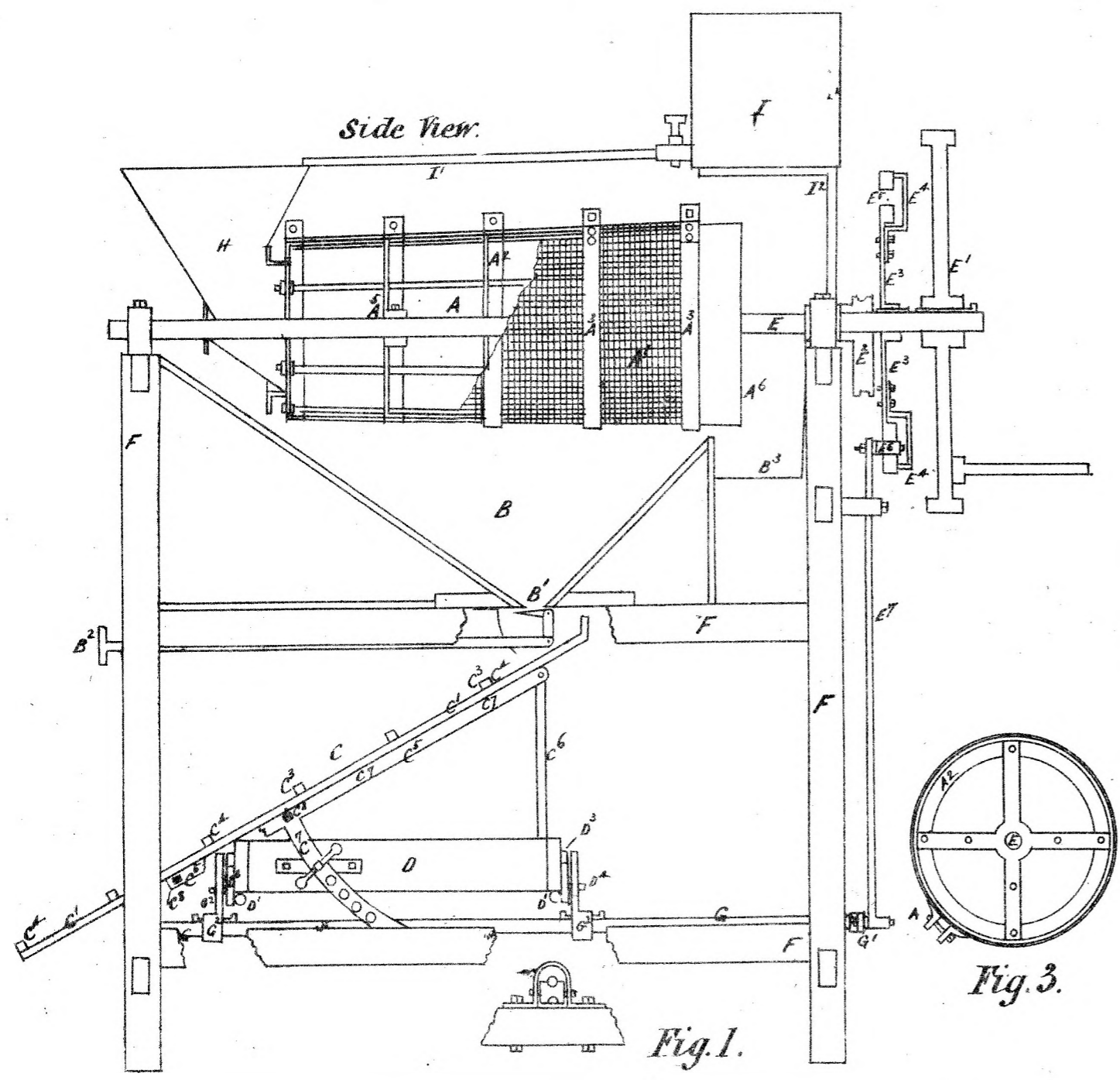


Fig. 1.

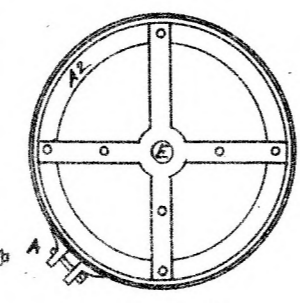


Fig. 3.

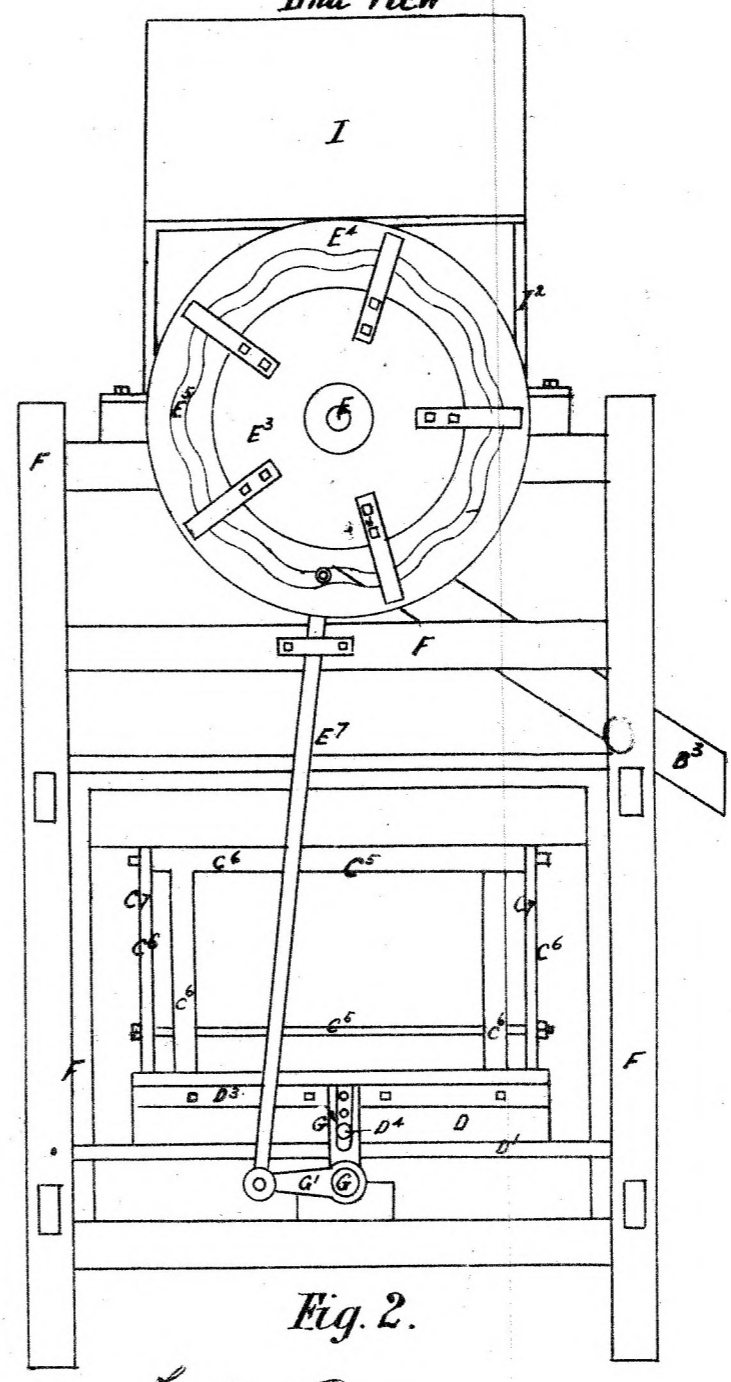


Fig. 2.

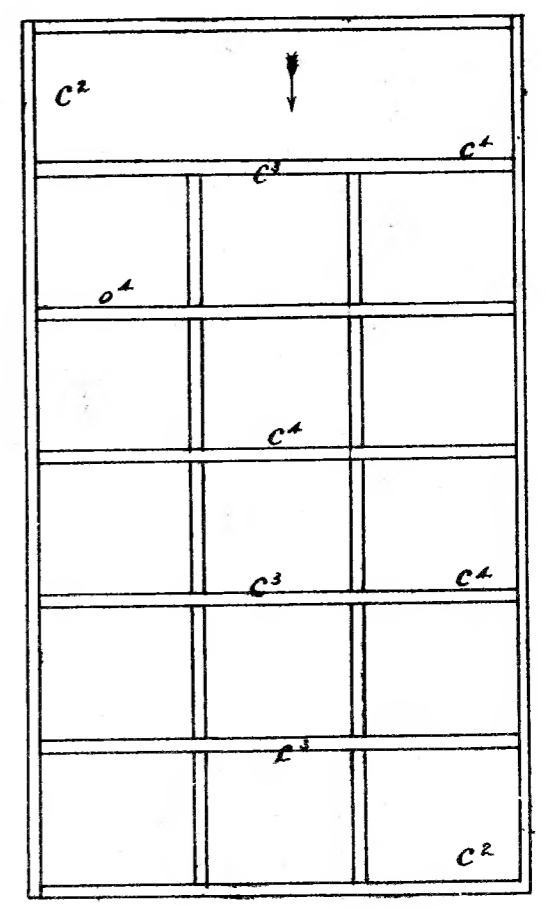


Fig. 5.

This is the Sheet of Drawings referred to in the annexed Letters of Registration granted to Joseph Carter, the 4th day of January, A.D. 1884.

(Sig 245)

Augustus Loftus.

Joseph Carter
19th October 1883.



A.D. 1884, 4th January. No. 1350.

AN IMPROVED MACHINE FOR THE MANUFACTURE OF WIRE NETTING.

LETTERS OF REGISTRATION to John Lysaght, for an Improved Machine for the Manufacture of Wire Netting.

[Registered on the 4th day of January, 1884, in pursuance of the Act 16 Vic. No. 24.]

BY HIS EXCELLENCY THE RIGHT HONORABLE SIR AUGUSTUS WILLIAM FREDERICK SPENCER LOFTUS (commonly called LORD AUGUSTUS LOFTUS), Knight Grand Cross of the Most Honorable Order of the Bath, a Member of Her Majesty's Most Honorable Privy Council, Governor and Commander-in-Chief of the Colony of New South Wales and its Dependencies.

TO ALL TO WHOM THESE PRESENTS SHALL COME, greeting :

WHEREAS JOHN LYSAGHT, of Bristol, England, wire-netting manufacturer, hath by his Petition humbly represented to me that he is the author or designer of a certain invention or improvement in manufactures, that is to say, of an invention entitled "An Improved Machine for the Manufacture of Wire Netting," which is more particularly described in the specification and the sheet of drawings which are hereunto annexed; and that he, the said Petitioner, hath deposited with the Honorable the Treasurer of the said Colony of New South Wales the sum of Twenty Pounds sterling for defraying the expense of granting these Letters of Registration, as required by the Act of Council, sixteenth Victoria, number twenty-four, and hath humbly prayed that I would be pleased to grant Letters of Registration whereby the exclusive enjoyment and advantage of the said invention or improvement might be secured to him for a period of fourteen years: And I, being willing to give encouragement to all inventions and improvements in the arts or manufactures which may be for the public good, and having received a report favourable to the prayer of the said Petition from competent persons appointed by me to examine and consider the matters stated therein and to report thereon for my information, am pleased, with the advice of the Executive Council, and in exercise of the power and authority given to me by the said Act of Council, to grant, and do by these Letters of Registration grant unto the said John Lysaght, his executors, administrators, and assigns, the exclusive enjoyment and advantage of the said invention or improvement for and during the term of fourteen years from the date hereof; to have, hold, and exercise unto the said John Lysaght, his executors, administrators, and assigns, the exclusive enjoyment and advantage thereof, for and during and unto the full end and term of fourteen years from the date of these presents next and immediately ensuing, and fully to be complete and ended: Provided always, that if the said John Lysaght shall not within three days after the granting of these Letters of Registration, register the same in the proper office in the Supreme Court, at Sydney, in the said Colony of New South Wales, then these Letters of Registration, and all advantages whatsoever hereby granted, shall cease and become void.

In witness whereof, I have hereunto set my sign manual, and have caused the present Letters of Registration to be sealed with the seal of the said Colony of New South Wales, at Government House, Sydney, in New South Wales, this fourth day of January, in the year of our Lord one thousand eight hundred and eighty-four.

[L.S.]

AUGUSTUS LOFTUS.

An Improved Machine for the Manufacture of Wire Netting.

SPECIFICATION of JOHN LYSAGHT, of Bristol, in England, wire-netting manufacturer, for an invention entitled "An Improved Machine for the Manufacture of Wire Netting."

My improved machine for the manufacture of wire netting consists of certain mechanical devices and arrangements for twisting the wire, forming the mesh, and making the selvage, and of certain other mechanical devices and arrangements for giving the necessary motion to those first mentioned.

In my machine there is a number of vertical tubes which I use as stem bobbins, whose terminations at top and bottom are split into two halves, the one of which remains a permanent part of the tube, while the other is alternately a part of it, and then separated from it. Around each of these permanent halves there is a half pinion cast, and around each of these non-permanent halves there is another half-pinion, so that when the non-permanent halves form part of said vertical tubes there is a complete pinion around each of them. These pinions are worked by two racks, one at the top and the other at the bottom, one to work each set of pinions, and both are so arranged and connected as to work simultaneously, and the motion is such that when the tubes have been rotated three times they come to a standstill, and are slid with their permanent terminations the exact distance between one tube and another, leaving the non-permanent termination of number 1 tube to form for the time being a part of number 2 tube, and so on all along the line of such tubes. The three rotations of the vertical tubes effect the twisting of the wire, and when slid along, as described, they are in gear for a return motion of three rotations, by which the twisting of the wire is effected for the next mesh, and so on alternately to and fro. After this return motion of three rotations they are slid back to their former non-permanent half terminations. One set of wires is supplied from suitably arranged bobbins at the back of the machine, and the other from the tubes themselves, which form the bobbins for such second wires. The first-mentioned wires each pass upward through the non-permanent halves of the tube terminations at both the bottom and the top, while the others each pass through the permanent halves at the top only, and both sets of wires being first fastened to and then guided by pegs on a pegged roller, which assist in determining the shape and size of the mesh) the netting is woven, except the selvage. The wires which form the selvage—preferably two for each—are supplied from two bobbins on a rotatory frame at the back of the machine, and passing through holes in the bottom of said frame, are thereby twisted, and then takes the place of one of the wires through the non-permanent half terminations on each side of the netting, and thus form the selvage which completes the netting. This is taken from said pegged roller and wound on a large plain roller at the upper and back part of the machine until it is loaded, when the netting is cut, the loaded roller removed, and an empty one supplied in its place. There may, of course, be any number of said wire feeding tubes and bobbins, so as to make the maximum width of netting the machine is intended to make, but any less than this width can as readily be made as the full width, or two or more different widths may be made at one and the same time.

In order to give the necessary motion to these parts, I have invented certain special devices and mechanical combinations, which are, however, of only secondary importance, and these, together with the actual net-making machinery, I have clearly illustrated in my drawings, in which figure 1 shows an end elevation of a complete machine, and figure 2 a front elevation, omitting shaft B, and bevel wheels B³ and C³ for the sake of clearness, and figure 3 a plan of the same, omitting the top stays A² for the same reason. The two latter figures show only one of my selvage-twisting contrivances, the construction of which is most clearly shown in figure 1. Figure 4 shows a section through line *aa* in figure 2. Figure 5 is an elevation of one of my vertical tubes or stem bobbins with its permanent and non-permanent terminations all joined together; figure 6, section of permanent and non-permanent top terminations; and figure 7 a similar view of those at the bottom; figures 8, 9, and 10 are sections on lines *b*, *c*, and *d* respectively in figure 5; and figure 11 is partial plan and figure 12 section of pegged roller.

A is the main framing of the machine, A¹ cross frames, and A² stays. B is driving-shaft; B¹ a fast pulley; B² fast and loose pulleys; B³ a bevel pinion; B⁴ an eccentric; and B⁵ a hand-wheel. C is main shaft; C¹ cams thereon; C² bevel-wheel; and C³ spur-wheel. DD are shafts, each having a spur-wheel D¹ on one end, and a disc D² on the other end. D³ are crank pins, and D⁴ connecting rods. E is a D-frame; E¹ friction rollers; E² guide pin; E³ extension of said D-frame, attached to the back-half F¹ of slides F, the two halves being connected together by equalizers F² at top and bottom; F³ are strengthening trusses; F⁴ are set screws through frames bearing on block F⁵ (see figure 4) to keep slides in place. GG¹ are racks, one at the top and the other at the bottom; G² are liners; and G³ set screws through slides. Referring now especially to figures 5 and 10, H are the vertical tubes or stem bobbins; H¹ the permanent top termination; H² the permanent bottom termination; H³ the non-permanent top termination, and H⁴ the non-permanent bottom termination; H⁵ is a sliding pin or "tompion"; and H⁶ fixed pin; H⁷ and H⁸ are the half pinions affixed respectively to the upper and lower terminations; H⁹H⁹ are steel faces brazed in the non-permanent halves of both top and bottom terminations, and also at the top of the permanent termination, and are for the purpose of making these faces more durable. I is pegged roller; I¹ being the pegs for the mesh, and I² the hoops for the selvages, the end ones being only half hoops. I³ is a pawl and ratchet motion, and I⁴ a stop pawl; I⁵ is a pulley. J is winding roller; J¹ its driving pulley; J² a tension contrivance for the band or belt. KK are feeding bobbins and K¹ a guide roller. L is a longitudinal shaft; L¹ driving pulley; L² sliding mitre wheels. M selvage bobbin frames sliding on shafts M¹ and M²; M³ mitre-wheels, and M⁴ the selvage bobbins.

The mode of operation is as follows:—Tubes H are first wound with as much wire as they will conveniently carry, and as many as are required are placed in position by inserting the lower end over pin H⁶ (see figure 7) and raising tompion H⁵ (see figure 6) and allowing it to drop into the upper end of the tube, as shown in dotted lines in the upper part of figure 5. The loose end of the wire is then guided through hole H¹⁰ (see figure 6) in the permanent half of top termination H¹, and fastened to that one of the pegs on pegged roller I, which is nearest to it. Feed bobbins K are also supplied with as much wire as they will conveniently carry, and the loose end of each wire passed once or twice round roller K¹, thence up through hole H¹¹ in one of the lower and H¹² (see figures 6 and 7) in one of the upper non-permanent terminations, and finally fastened to one of the pegs on pegged roller I. Selvage bobbins M⁴ are also supplied with wire, the two ends from which pass through two separate holes in the bottom of the framing M, and, being twisted, are conducted through the hole in one of the non-permanent halves at the

An Improved Machine for the Manufacture of Wire Netting.

the bottom, and then through the hole in one of the non-permanent halves at the top of the tubes or stem bobbins H, in the same way as one of the ordinary wires which form part of the mesh. These frames M, and the mitre-wheels L², are fixed by set screws at such a distance apart as to feed their wires in the exact position required for forming the selvage of the wire netting which is being woven. It is necessary that there should be one extra non-permanent termination, no matter what is the width of the netting being made.

The machine being now started, the vertical tubes or stem bobbins H will revolve exactly three times, thus giving three twists to the wires, which pass respectively through the permanent and non-permanent terminations of each such tube. This motion is directly imparted by means of the cranks G and G¹, actuating pinions H⁷ and H⁸, said racks being worked by connecting rods D⁴, from discs D², as shown. Just as the stroke of the connecting rod is completed the cam C¹ on shaft C moves half slides F¹ the one way and the equalizers F², at the same time give motion in an opposite direction to the other half slides F¹, so that the tubes with their upper and lower permanent half terminations H¹ and H², and the wire through holes H¹⁰, leave their first non-permanent terminations H³ and H⁴, and take up with other non-permanent half terminations to the right or left of them, as the case may be, and will then again revolve three times in an opposite direction, after which they will be returned to their original non-permanent half terminations, and so on as long as may be desired. The three revolutions of the tubes give the twist to the wires, and the pegged roller I then moves one-twentieth of a revolution by reason of the pawl and ratchet I³ (see figure 1) and lifts the formed mesh, by means of pins I¹, ready for the next twist, thus lifting four distinct times to form one mesh, and just putting the proper strain on the wires so that the twist shall be regular and of the same size. The hoops F² are for lifting the selvage and for keeping the width from contracting, which it has a tendency to do, but which the angular shape of the hoops prevent, the strain spreading the width.

As the woven netting is wound on the roller J, the driving belt which gears over pulleys I⁵ and J¹ requires straining, and for this purpose I have provided the tension device J², which is centred at J³, and has friction rollers J⁴ at the end of each of its arms J², and a long arm J⁶, having a hooked end on which I hang a weight sufficient for the purpose required, as will be clearly understood on reference to figure 1.

Having thus described the nature of my improved machine for the manufacture of wire netting, and the manner of performing same, I would have it understood that what I believe to be new in such machine, and for which, therefore, I am desirous of securing Letters of Registration, is,—

First—The hollow revolving stems or bobbins H, with their permanent terminations H¹ and H², and their non-permanent terminations H³ and H⁴, constructed in the manner and for the purposes herein described and explained, and as illustrated in my drawings.

Second—The combination and arrangement of the feed bobbin K with the contrivances described in the preceding claim.

Third—The combination and arrangement of the revolving selvage bobbins M¹, and their framing M with the other contrivances, herein described and explained and illustrated in my drawings, for making the wire netting.

Fourth—The half pinions H⁷ and H⁸, constructed on the permanent and the non-permanent terminations of the stems or bobbins H, and their combination with the racks G and G¹ for the purposes described.

Fifth—The combination and arrangement of the cams C¹ and friction rollers E¹ with the framing E and E² for imparting the necessary motion to the slides FF¹, which carry racks G and G¹, and move the stems or bobbins H, substantially as and for the purposes described.

Sixth—The tension device J², for preserving an even and regular strain on the netting as it is made, so as to wind it tightly on the receiving roller.

Seventh—The combination of the pegged drum or shaft I with the stems or bobbins H, substantially as and for the purposes herein described and explained.

In witness whereof, I, the said John Lysaght, have hereto set my hand and seal, this eighth day of October, one thousand eight hundred and eighty-three.

JOHN LYSAGHT,

By his Agent, JNO. DAVEY.

Witness—

EDWD. WATERS,
Melbourne, Patent Agent.

This is the specification referred to in the annexed Letters of Registration granted to John Lysaght, this 4th day of January, A.D. 1884.

AUGUSTUS LOFTUS.

REPORT.

Sir,

We do ourselves the honor to report, in reply to your blank cover transmitting the petition of John Lysaght for the registration of "An Improved Machine for the Manufacture of Wire Netting," that we are of opinion that the prayer of the Petitioner may be granted, in terms of his specification, drawings, and claim.

The Under Secretary of Justice.

Sydney, 22 October, 1883.

We have, &c.,

JAMES BARNET,
GOTHER K. MANN.

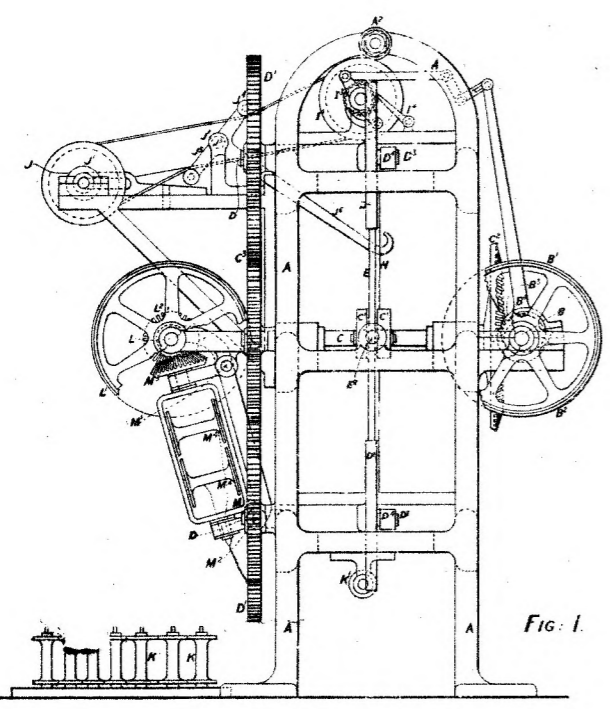


Fig. 1.

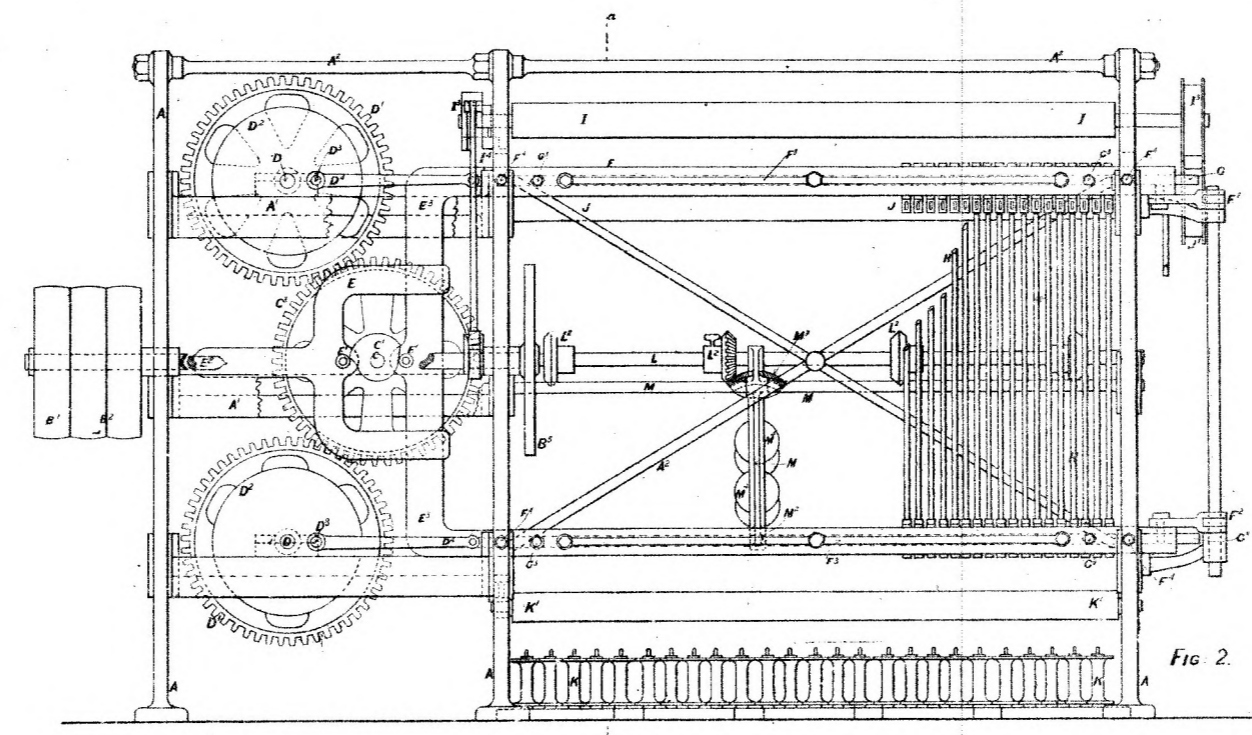


Fig. 2.

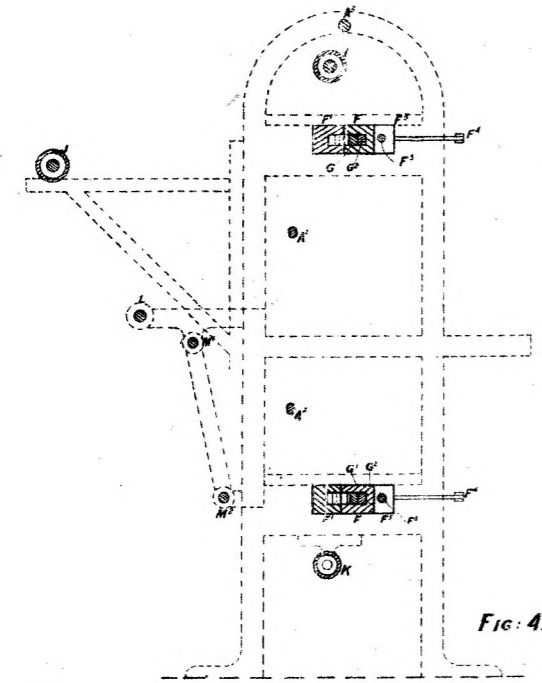


Fig. 4.

— JOHN LYSACHT'S PATENT —

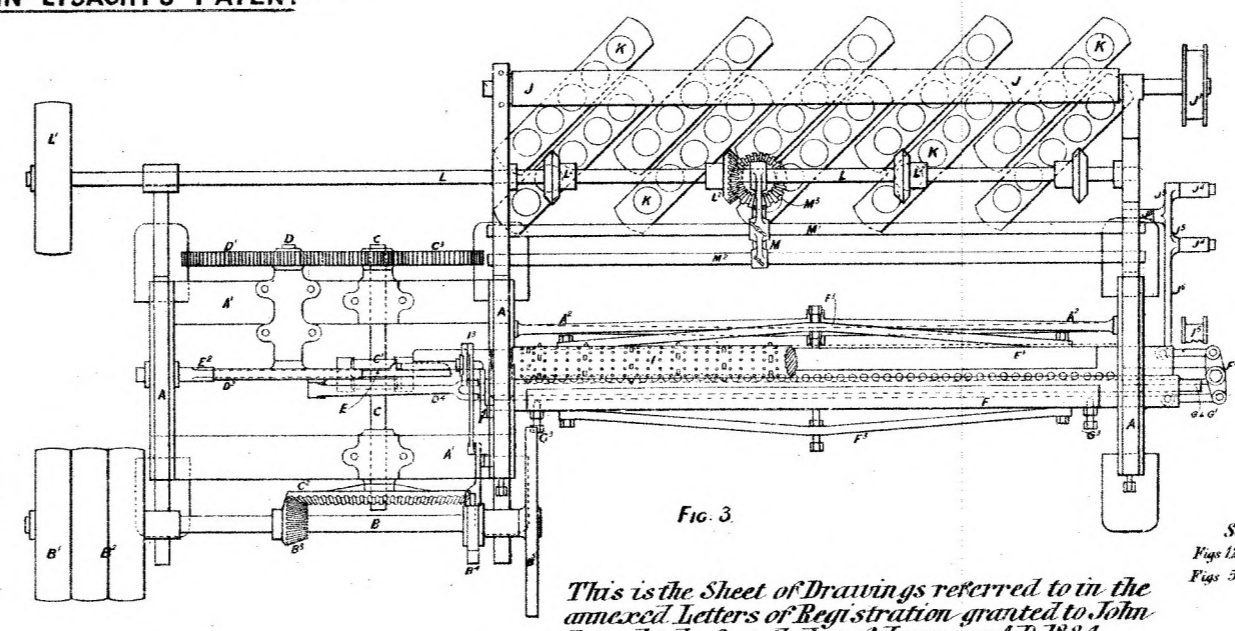


Fig. 3.

This is the Sheet of Drawings referred to in the annexed Letters of Registration granted to John Lysacht, the fourth day of January A.D. 1884 Augustus Loratus.

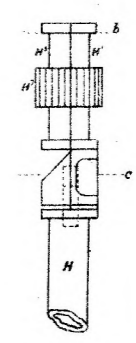


Fig. 5.

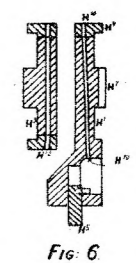


Fig. 6.

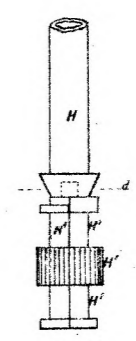


Fig. 7.





A.D. 1884, 4th January. No. 1351.

IMPROVEMENTS IN THE MODE OF AND MACHINE FOR PULVERIZING ORES, &c.

LETTERS OF REGISTRATION to Frederic Augustus Luckenbach, for Improvements in the mode of and Machine for Pulverizing Ores and other substances.

[Registered on the 4th day of January, 1884, in pursuance of Act 16 Vic. No. 24.]

BY HIS EXCELLENCY THE RIGHT HONORABLE SIR AUGUSTUS WILLIAM FREDERICK SPENCER LOFTUS (commonly called LORD AUGUSTUS LOFTUS) Knight Grand Cross of the Most Honorable Order of the Bath, a Member of Her Majesty's Most Honorable Privy Council, Governor and Commander-in-Chief of the Colony of New South Wales and its Dependencies.

TO ALL TO WHOM THESE PRESENTS SHALL COME, greeting :

WHEREAS FREDERIC AUGUSTUS LUCKENBACH, of the city and State of New York, United States of America, engineer, hath by his Petition humbly represented to me that he is the author or designer of a certain invention or improvement in manufactures, that is to say, of an invention entitled "Improvements in the mode of and Machine for Pulverizing Ores and other substances," which is more particularly described in the specification and the sheet of drawings which are hereunto annexed; and that he, the said Petitioner, hath deposited with the Honorable Treasurer of the said Colony of New South Wales the sum of Twenty Pounds sterling, for defraying the expense of granting these Letters of Registration, as required by the Act of Council, sixteenth Victoria, number twenty-four; and hath humbly prayed that I would be pleased to grant Letters of Registration, whereby the exclusive enjoyment and advantage of the said invention or improvement might be secured to him for a period of fourteen years: And I, being willing to give encouragement to all inventions and improvements in the arts or manufactures which may be for the public good, and having received a report favourable to the prayer of the said Petition, from competent persons appointed by me to examine and consider the matters stated therein and to report thereon for my information, am pleased, with the advice of the Executive Council, and in exercise of the power and authority given to me by the said Act of Council, to grant, and do, by these Letters of Registration grant unto the said Frederic Augustus Luckenbach, his executors, administrators, and assigns, the exclusive enjoyment and advantage of the said invention or improvement, for and during the term of fourteen years from the date hereof; to have, hold, and exercise unto the said Frederic Augustus Luckenbach, his executors, administrators, and assigns, the exclusive enjoyment and advantage thereof, for and during and unto the full end and term of fourteen years from the date of these presents next and immediately ensuing, and fully to be complete and ended: Provided always, that if the said Frederic Augustus Luckenbach shall not, within three days after the granting of these Letters of Registration, register the same in the proper office in the Supreme Court, at Sydney, in the said Colony of New South Wales, then these Letters of Registration, and all advantages whatsoever hereby granted, shall cease and become void.

In witness whereof, I have hereunto set my sign manual, and have caused the present Letters of Registration to be sealed with the seal of the said Colony of New South Wales, at Government House, Sydney, in New South Wales, this fourth day of January, in the year of our Lord one thousand eight hundred and eighty-four.

[L.S.]

AUGUSTUS LOFTUS.

Improvements in the Mode of and Machine for Pulverizing Ores, &c.

SPECIFICATION of FREDERIC AUGUSTUS LUCKENBACH, of the city and State of New York, United States of America, for an Invention of "Improvements in the Mode of, and Machine for, Pulverizing Ores and other substances."

THE said invention relates to the pulverization of ores and other substances by concussion or direct impact of such substances when carried in opposing currents to a focal or central point. The material to be pulverized falls or is drawn into these currents by a partial vacuum which these currents produce in the inlet passages, and are then carried forward in these currents with great velocity until the two streams of material come in collision. The currents are created by means of super-heated steam, compressed air, or other suitable forces; but it has been shown by practical tests that super-heated steam, under ordinary conditions, is preferable to other forces.

The opposing streams meeting at the point of impact produces rapid pulverization with a comparatively small amount of power, and little wear of the machine, which is simple and inexpensive in its construction. The machine may be adapted for more than two opposing currents if desired, but experience has shown that the most advantageous form of machine is that shown in the accompanying drawing, in which figure 1 is a vertical central section of the machine, and figures 2 and 3 are detached views of the parts of the same.

A is the receiving hopper; B B, charging hoppers; M M, hopper supporting rods; N N, hopper outlet valves; N¹ N¹, material inlet passages; C C, flanged conducting tubes; C¹ C¹, tube holders or bushings; D D, charged currents; E, pulverization chamber; F, discharge pipe; H H, steam or air chambers; K K, removable caps or plugs; H¹ H¹, steam or air nozzle with removable ends *h h*; G, main steam or air pipe, and *g g* the branches; O, divisional plate in pipe G; J, steam exhaust pipe; L, body; and I I the supports of the machine.

The passage of the material from hopper A to hoppers B B is regulated by the slide valves N N. The rods M M form a support for the hopper A. The material falls or is drawn into the currents D D through the passages N¹ N¹ formed around the nozzle H¹ H¹. The conducting tubes C C, the inner periphery of which may be varied to adapt them to the size of the material and the amount of force employed, are made of cast iron or steel, with chilled inner surfaces, or they may be provided with a lining of hard metal, glass, or other material. They are made removable in order that they may be readily replaced when worn. They are placed in the tube-holders C¹ C¹, and are held therein by set screws. They are provided with flanges, as shown at their inner end, to protect the adjacent portions of the machine. The proper form and arrangement of these conducting tubes have been ascertained by practical tests.

The pulverizing chamber E extends to a receiver overhead, into which the powdered material is carried by the currents, the portions of the material not sufficiently fine passing down the discharge pipe F.

This chamber is fitted tightly to the frame of the machine, and is provided with a door or covered opening in front to afford easy access to the interior of the machine, and especially to the conducting tube C C. A damper is employed in pipe J to regulate the escape of steam from the chamber E. The steam or air chambers H H, as shown, are formed of the nozzles H¹ H¹ and the removable cap K. This form of connection is convenient and inexpensive. The nozzles are formed of gun metal or other suitable material, and have removable ends *h h*. These ends or tips may be constructed with different sized central openings, and may readily be replaced, the object being to regulate the egress of steam to adapt the force to the work to be done. When it is desired to replace these tips the nozzles H¹ H¹ are removed from the machine. Access to these nozzles is obtained by first removing caps or plugs K K. The nozzles and tubes C C must be so fitted that the interior aperture will be in perfect alignment in order to secure the best results.

The steam or air supply pipe G connects with the steam chambers H H through the branch supply pipes *g g*, and is also connected with a suitable generator of the force employed. The branch pipes *g g* should be of equal size, and also the steam chambers H H, in order to produce currents of equal force and velocity. A divisional plate O, the width of the diameter of pipe G, is placed in the upper end of the pipe G, to ensure an equal supply of the steam to the branch pipes *g g* and the chamber H H. This plate is screwed to the pipe connection, as shown in figure 3, or otherwise secured in place. The supports of the machine are preferably made of metal tubing.

The ore or other substance to be pulverized is first crushed in the usual manner to the requisite size to pass through the passages N¹ N¹ and conducting tubes C C. The material may be passed through a screen sufficiently fine to prevent the passage of any pieces of material that would clog the passages of conducting tubes C C. A screen of about $\frac{1}{4}$ inch mesh is generally employed. The steam is super-heated to about 600 or 800 degrees Fahrenheit, under a pressure of 150 to 180 lb. to the square inch, and then admitted to the chambers H H, the valve of exhaust pipe J being open until no condensation is perceptible. This valve is then closed, and the valves N N are opened. The material falls into the passages N¹ N¹ around the nozzles H¹ H¹, from which passage it is drawn into the conducting tubes C C by a partial vacuum, caused by the passage of the steam or air, and is then carried forward in the currents to the focal point, or point of contact, with great velocity, thereby bringing the two opposing streams into violent collision and producing the desired pulverization. The portions of the material not sufficiently pulverized pass through the discharge pipe F, and powdered material passes up the chamber E into a suitable receiver. The portion not pulverized is returned again to hopper A, and the operation is continued.

Having thus fully described said improvements, I claim as my invention—

First—The hereinbefore described method of pulverizing ores and other substances by the employment of two or more opposing currents substantially as set forth.

Second—The combination of the parts of the machine for the purpose and constructed substantially as set forth.

Third—The nozzles H¹ H¹ provided with interchangeable screw ends for the purpose and constructed substantially as set forth.

Fourth—

Improvements in the Mode of and Machine for Pulverizing Ores, &c.

Fourth—The removable conducting tubes C C inserted in holders C' C', for the purpose and constructed substantially as set forth.

Fifth—The divisional plate O for the purpose and arranged substantially as set forth.

In witness whereof, I, the said Frederic Augustus Luckenbach, have hereto set my hand and seal, this seventh day of April, one thousand eight hundred and eighty-three.

FREDERIC AUGUSTUS LUCKENBACH.

This is the specification referred to in the annexed Letters of Registration granted to Frederick Augustus Luckenbach, the fourth day of January, A.D. 1884.

AUGUSTUS LOFTUS.

REPORT.

Sir,

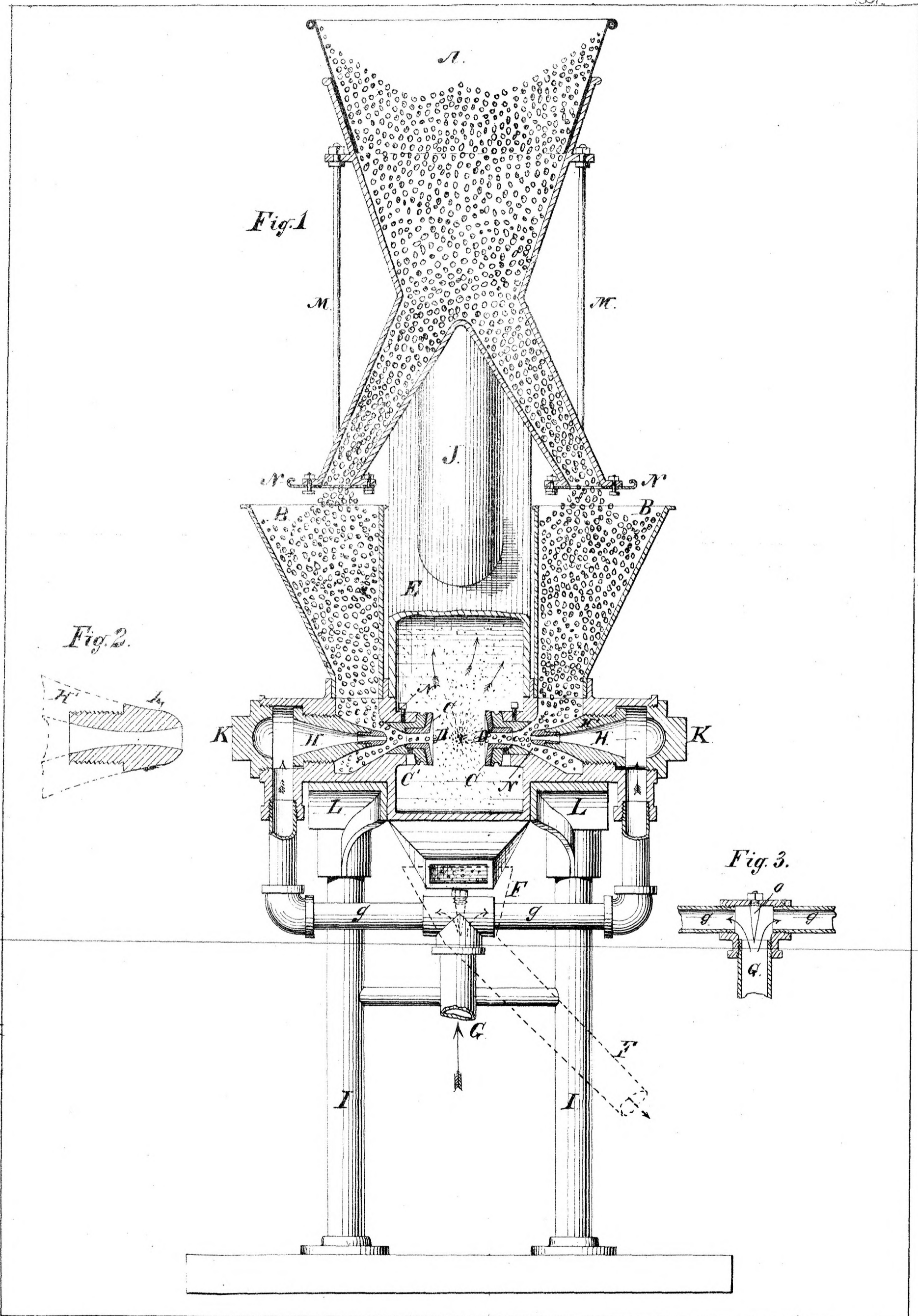
Sydney, 4 October, 1883.

The petition of Mr. Frederic Augustus Luckenbach, for Letters of Registration for an invention entitled "Improvements in the Mode of and Machine for Pulverizing Ores and other substances" having been referred to us, we have examined the specification and drawings accompanying the same, and have the honor to report that we see no objection to the granting of Letters of Registration as prayed for.

We have, &c.,
J. SMITH.
A. LEIBIUS.

The Under Secretary of Justice.

[Drawings—one sheet].



This is the Sheet of Drawings referred to in the annexed Letters of Registration granted to Frederic Augustus Luokenbach, the fourth day of January, A.D., 1884.

Augustus Loftus.

PHOTO-LITHOGRAPHED AT THE GOVY. PRINTING OFFICE, SYDNEY, NEW SOUTH WALES.

(Sig 245-)



A.D. 1884, 4th January. No. 1352.

IMPROVEMENTS IN PROPELLERS, &c.

LETTERS OF REGISTRATION to Edward Beaufort Cullen, for Improvements in Propellers and in the construction of Ships suitable therefor.

[Registered on the 4th day of January, 1884, in pursuance of the Act 16 Vic. No 24.]

BY HIS EXCELLENCY THE RIGHT HONORABLE SIR AUGUSTUS WILLIAM FREDERICK SPENCER LOFTUS (commonly called LORD AUGUSTUS LOFTUS), Knight Grand Cross of the Most Honourable Order of the Bath, a Member of Her Majesty's Most Honourable Privy Council, Governor and Commander-in-Chief of the Colony of New South Wales and its Dependencies.

TO ALL TO WHOM THESE PRESENTS SHALL COME, greeting :

WHEREAS EDWARD BEAUFORT CULLEN, of Brisbane, in the Colony of Queensland, gentleman, hath by his Petition humbly represented to me that he is the author or designer of a certain invention or improvement in manufactures, that is to say, of an invention entitled "Improvements in Propellers, and in the construction of Ships suitable therefor," which is more particularly described in the specification and sheet of drawings which are hereunto annexed ; and that he the said Petitioner hath deposited with the Honorable the Treasurer of the said Colony of New South Wales the sum of Twenty Pounds sterling, for defraying the expense of granting these Letters of Registration, as required by the Act of Council, sixteenth Victoria, number twenty-four, and hath humbly prayed that I would be pleased to grant Letters of Registration, whereby the exclusive enjoyment and advantage of the said invention or improvement might be secured to him for a period of fourteen years. And I, being willing to give encouragement to all inventions and improvements in the arts or manufactures which may be for the public good, and having received a report favourable to the prayer of the said Petition, from competent persons appointed by me to examine and consider the matters stated therein, and to report thereon for my information, am pleased, with the advice of the Executive Council, and in exercise of the power and authority given to me by the said Act of Council, to grant, and do by these letters of Registration grant unto the said Edward Beaufort Cullen, his executors, administrators, and assigns, the exclusive enjoyment and advantage of the said invention or improvement, for and during the term of fourteen years from the date hereof ; to have, hold, and exercise unto the said Edward Beaufort Cullen, his executors, administrators, and assigns, the exclusive enjoyment and advantage thereof, for and during and unto the full end and term of fourteen years from the date of these presents next and immediately ensuing, and fully to be complete and ended : Provided always, that if the said Edward Beaufort Cullen shall not, within three days after the granting of these Letters of Registration, register the same in the proper office in the Supreme Court at Sydney, in the said Colony of New South Wales, then these Letters of Registration, and all advantages whatsoever, hereby granted, shall cease and become void.

In witness whereof, I have hereunto set my sign manual, and have caused the present Letters of Registration to be sealed with the seal of the said Colony of New South Wales, at Government House, Sydney, in New South Wales, this fourth day of January, in the year of our Lord one thousand eight hundred and eighty-four.

[L.S.]

AUGUSTUS LOFTUS.

Improvements in Propellers, &c.

SPECIFICATION.

SPECIFICATION of EDWARD BEAUFORT CULLEN, of Brisbane, in the Colony of Queensland, gentleman, for an invention entitled "Improvements in Propellers, and in the construction of Ships suitable therefor."

My invention has been designed so that a greater proportion than hitherto of the power generated by the engines of steamships may perform useful work.

My improvements in propellers consist, first and mainly, of a series of blades carrying buckets or spoons at their opposite extremities or sides, and affixed anglewise to a shaft. One of such shafts is placed horizontally on each side of the ship, in a longitudinal chamber running along the outside and clear of the main hull. The buckets or spoons are placed at the edge and on opposite sides of each blade, so that when revolving the leading face presents a sharp angular edge to the water, and the trailing face presents a hollow or spoon face. They are perforated throughout from face to face. This portion of the invention further consists of a novel construction of crank to be used, as hereinafter more particularly described.

My improvements in the construction of ships suitable for my propellers consist in building them with a casing on either side of the main hull, and open at either end to the water; but with a cage or grating to prevent the entrance of large fish and solid bodies of any considerable size. These casings are fixed to or built upon the side of the main hull, so as to contain or enclose said propellers. This casing springs from the keel or bilge of the ship, and at the 'tween or lower deck, or just above the water-line, is joined by sponsons tapering towards the bow and stern to the main hull. Above such sponsons the casing is continued upwards to form extra cabins or stowage spaces, which extra cabins or spaces have decks corresponding to the decks of the ship. Below the sponsons are stays extending downward to the main hull, and to the ends of the casing, so as to form the cage or grating above-mentioned.

But, in order that my invention may be clearly understood, reference will now be made to my drawings, hereto attached, in which figure 1 shows a side elevation of a ship constructed according thereto; figure 2, a bow or stern view, partly in section; and figure 3, a plan view, also partly in section; figure 4, an enlarged view of part of the propeller-shaft with two of my blades; and figure 5 an end view of the same. I prefer to have these blades made of either wood or wrought-iron, the spoons or buckets being always of wrought-iron; and I also prefer that these spoons or buckets should be made separately from and attached to the blades, so that in the event of breakage they can easily be removed and replaced. Figure 6 is an outline view, similar to figure 2; but in this case the motive power takes the form of a beam-engine, instead of a horizontal engine, as in the previous figure, while figure 7 is a detail of the crank-shaft, which becomes the propeller-shaft when a beam-engine is used.

A is the main hull of the ship, B the propeller casing, C the propeller-shaft, D the blades carrying buckets or spoons, D¹ and E the engine. The deck-frames, A¹ and A², I prefer should reach from outside to outside, across the main hull, so as to form continuous decks above the sponsons B¹; B² are stays joining sponson B¹ to the hull A and casing B. The propeller-shaft C, which I prefer to be of octagonal section, revolves in bearings C¹, at either end, and thrust bearing C² in centre, all supported on beams or girders C³, let in through the sides of the hull. The blades D are attached to said shaft C by a tang or spindle D², passing quite through it, and secured by nut D³. At the extremity of each opposite face of this blade is a bucket or spoon D⁴, which may form part of or be fastened to it. These blades are flat, or nearly so, and are perforated as shown. They are secured to each succeeding flat of the octagonal shaft C in rotation, and in such a number, of such a size, and fixed at such an angle as may be best fitted for the class of vessel to which they are to be attached, due regard being had to the required surface area of the propellers and to the power of the engines. I have found that the proportions shown give an excellent basis for calculation. E is an engine, of which I prefer to have two, whose shafts E¹ abut, and have a sliding coupling E², so that they may be worked as one engine, or as two independent engines. In vessels of greater beam than that shown in the drawings the boiler should be placed between the engines, so as to give greater stowage space. Shafts E¹ project through stuffing-boxes E³, and drive shaft C by means of bevel gearing E⁴.

Referring to figure 6, E⁵ is one of the beam-engines, the other being in a corresponding position on the other side of the vessel. E⁶ is the beam pivotted in bearings E⁷, E⁸ the outside connecting rod, and C⁴ the outside crank-shaft, having its checks, C⁵ (see figure 7), set at the same angle as the blades, so that they will act as extra propellers, and not offer resistance, as they would if of ordinary construction; C⁶ are the crank-pins.

It is plainly to be seen that when the engines are set in motion the blades D will be revolved, and propel the vessel as if they were so many screws; but, being confined in a casing, they act upon a body of water which gives a direct thrust against the still water surrounding the ship. By means of coupling E² one engine may go ahead while the other goes astern, and the vessel will then rotate almost as if she were upon a pivot.

By this method of construction, I am able to obtain a greater speed with a given amount of power than by any other, beside which I provide a vessel of safe and convenient form.

Having thus particularly described and ascertained my said invention, I would have it understood that what I believe to be new, and desire to secure by Letters of Registration, is—

First—The peculiar construction of the blades D, having buckets or spoons D¹, and either with or without the perforations, substantially as herein described and explained.

Second—

Improvements in Propellers, &c.

Second—The combination and arrangement of a number of my propelling blades D, on a horizontal shaft, placed longitudinally in chambers or casings, on either side of the vessel, substantially as herein described and explained.

Third—The construction of the crank C' (see figure 7), with angular checks C^s, to be used in the manner and for the purpose substantially as herein described and explained.

In witness whereof, I, the said Edward Beaufort Cullen, have hereto set my hand and seal, this twenty-fourth day of September, one thousand eight hundred and eighty-three.

EDWARD BEAUFORT CULLEN.

Witness—

FRED. WALSH,

Manager, Edwd. Waters' Patent Office, Sydney.

This is the specification referred to in the annexed Letters of Registration granted to Edward Beaufort Cullen, the fourth day of January, A.D. 1884.

AUGUSTUS LOFTUS.

REPORT.

Sir,

Sydney, 5 October, 1883.

In reply to your B.C. of the 29th ultimo, we have the honor to report that we have examined Mr. E. B. Cullen's application for Letters of Registration for an invention entitled "Improvements in Propellers, and in the construction of Ships suitable therefor"; also the specifications and plans therewith, and we see no reason why his application should not be granted.

We have, &c.,

FRANCIS HIXSON.
H. BRODERICK.

The Under Secretary of Justice.

[Drawings—one sheet.]

EDWARD BEAUFORT CULLEN'S, PATENT.

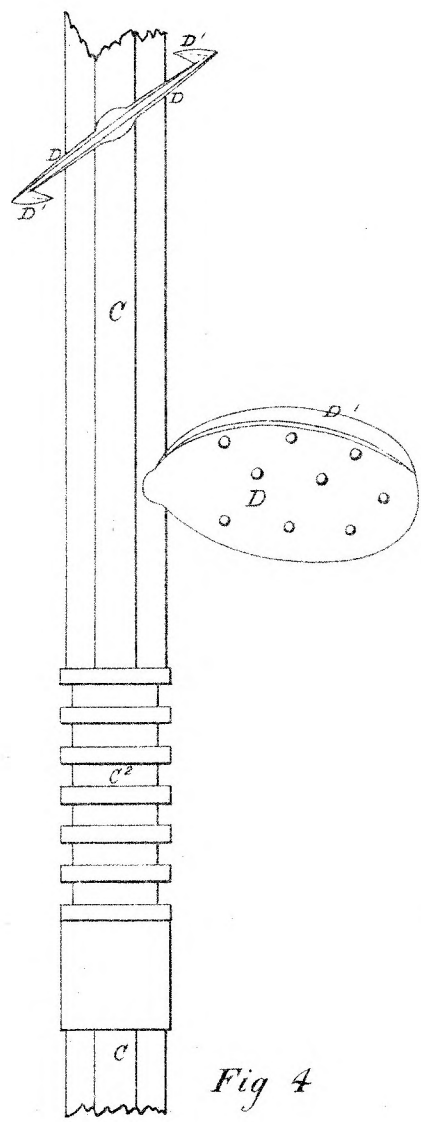


Fig 4

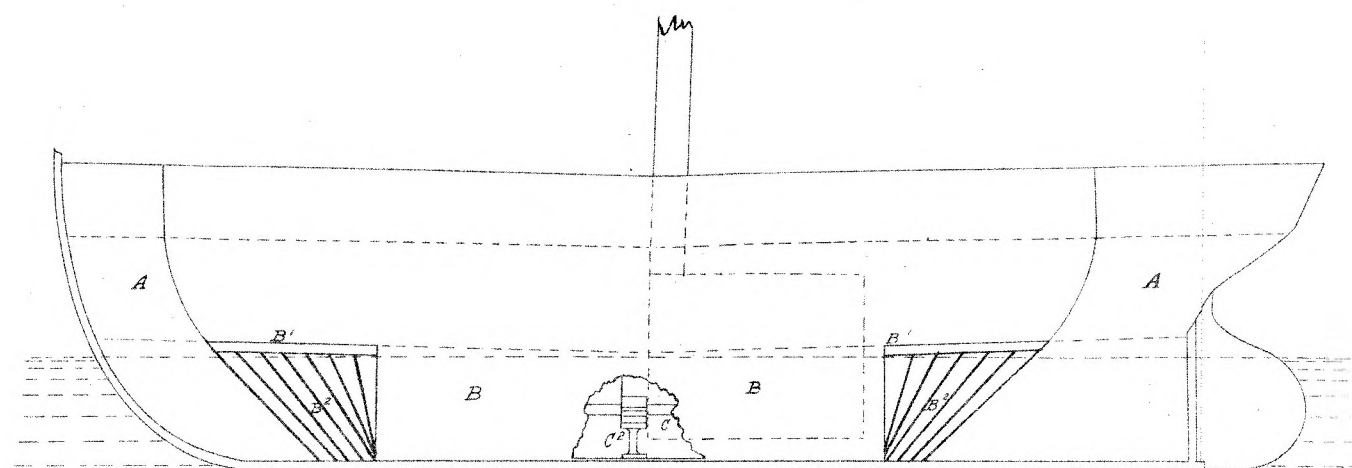


Fig 1

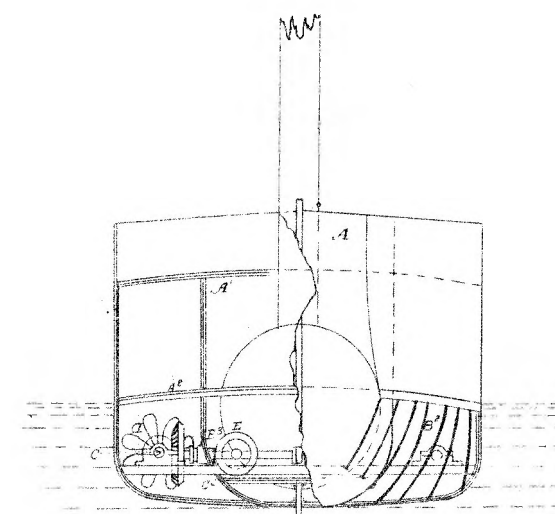


Fig 2

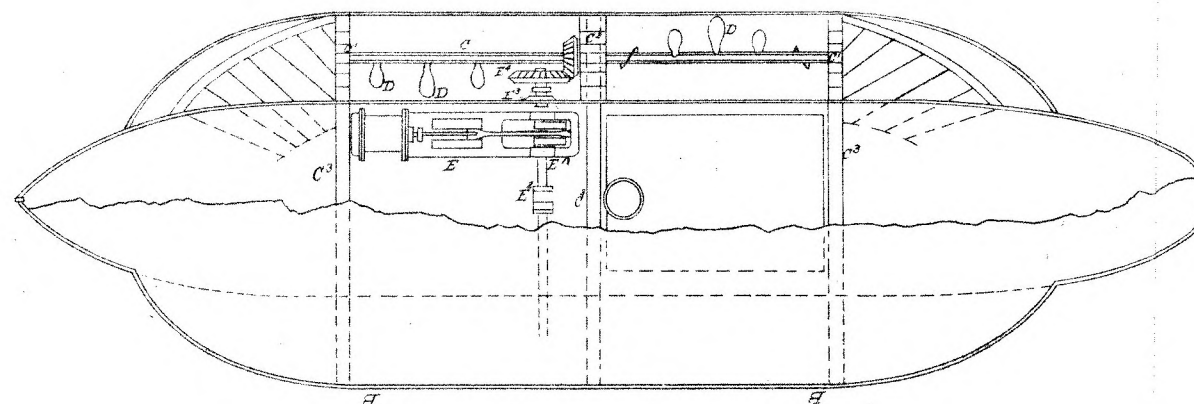


Fig 3

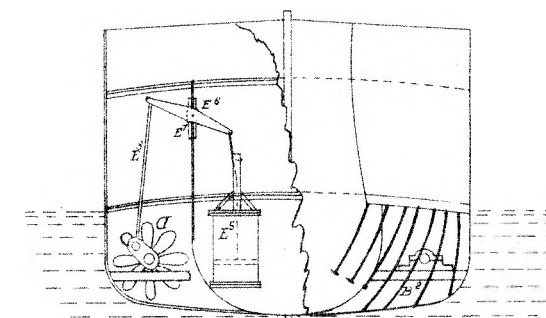


Fig 6

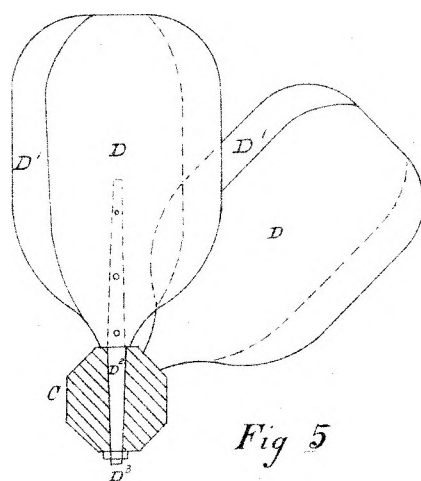


Fig 5

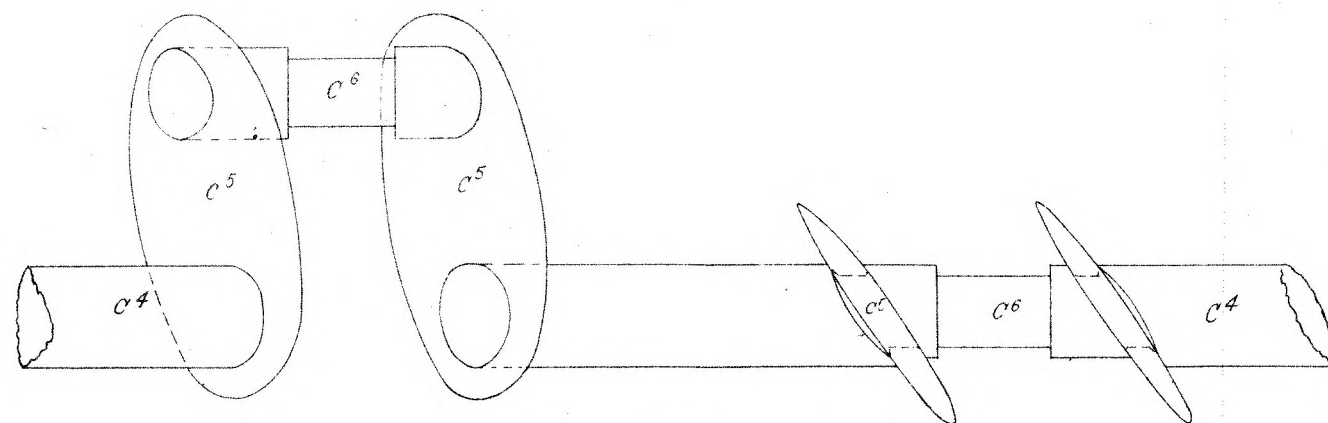


Fig 7

This is the Sheet of Drawings referred to in the annexed
Letters of Registration granted to Edward Beaufort Cullen,
the fourth day of January, AD, 1884.

Augustus Loftus.

Scale

Fig^s 1, 2, 3, & 6 $\frac{3}{16}$ in - 1 Foot
Fig^s 4, 5 & 7 $1\frac{1}{2}$ ins - 1 Foot

EDWARD WATERS,
Patent Agent
Sydney & Melbourne



A.D. 1884, 4th January. No. 1353.

IMPROVEMENTS IN FURNACES AND FLUES OF AND FOR STEAM-ENGINE
BOILERS.

LETTERS OF REGISTRATION to Adolph Herzog, for Improvements in Furnaces
and Flues of and for Steam-engine Boilers.

[Registered on the 4th day of January, 1884, in pursuance of the Act 16 Vic. No. 24.]

BY HIS EXCELLENCY THE RIGHT HONORABLE SIR AUGUSTUS WILLIAM FREDERICK SPENCER LOFTUS
(commonly called LORD AUGUSTUS LOFTUS), Knight Grand Cross of the Most Honorable Order of the
Bath, a Member of Her Majesty's Most Honorable Privy Council, Governor and Commander-in-Chief
of the Colony of New South Wales and its Dependencies.

TO ALL TO WHOM THESE PRESENTS SHALL COME, greeting :

WHEREAS ADOLPH HERZOG, of Sydney, in the Colony of New South Wales, mechanical engineer,
hath by his Petition humbly represented to me that he is the author or designer of a certain invention or
improvement in manufactures, that is to say, of an invention entitled "Improvements in Furnaces and Flues
of and for Steam-engine Boilers," which is more particularly described in the specification and the sheet
of drawings which are hereunto annexed; and that he, the said Petitioner, hath deposited with the
Honorable the Treasurer of the said Colony of New South Wales the sum of Twenty Pounds sterling, for
defraying the expense of granting these Letters of Registration, as required by the Act of Council,
sixteenth Victoria, number twenty-four; and hath humbly prayed that I would be pleased to grant Letters
of Registration, whereby the exclusive enjoyment and advantage of the said invention or improvement
might be secured to him for a period of fourteen years: And I, being willing to give encouragement to all
inventions and improvements in the arts or manufactures which may be for the public good, and having
received a report favourable to the prayer of the said Petition, from competent persons appointed by me to
examine and consider the matters stated therein and to report thereon for my information, am pleased, with
the advice of the Executive Council, and in exercise of the power and authority given to me by the said
Act of Council, to grant, and do by these Letters of Registration grant unto the said Adolph Herzog, his
executors, administrators, and assigns, the exclusive enjoyment and advantage of the said invention or
improvement, for and during the term of fourteen years from the date hereof; to have, hold, and exercise
unto the said Adolph Herzog, his executors, administrators, and assigns, the exclusive enjoyment and
advantage thereof, for and during and unto the full end and term of fourteen years from the date of these
presents next and immediately ensuing, and fully to be complete and ended: Provided always, that if the
said Adolph Herzog shall not, within three days after the granting of these Letters of Registration, register
the same in the proper office in the Supreme Court, at Sydney, in the said Colony of New South Wales,
then these Letters of Registration, and all advantages whatsoever hereby granted, shall cease and become
void.

In witness whereof, I have hereunto set my sign manual, and have caused the present Letters of
Registration to be sealed with the seal of the said Colony of New South Wales, at Govern-
ment House, Sydney, in New South Wales, this fourth day of January, in the year of our Lord
one thousand eight hundred and eighty-four.

[L.S.]

AUGUSTUS LOFTUS.

Improvements in Furnaces, &c.

SPECIFICATION of ADOLPH HERZOG, of Sydney, in the Colony of New South Wales, mechanical engineer, for an invention entitled "Improvements in Furnaces and Flues of and for Steam-engine Boilers."

My invention has been designed in order that the waste products of manufactories may be efficiently and economically utilized as fuel for the steam-engine boiler. It is more especially adapted for use in sugar factories or plantations, where it is desirable that the cane trash or "megasse" should form the fuel; it is such that the combustion of said fuel is more thorough and the result more effective than hitherto possible. It is equally economical with ordinary fuel, and is such that little or no smoke escapes up the chimney.

My improvements consist, first, in a novel construction of furnace, so as to ensure a gradual combustion of the fuel; and, secondly, in the combination and arrangement of flues, whereby a body of air, heated without direct contact or intermingling with the fire gasses or products of combustion, is distributed within the furnace.

My improved furnace has fire-bars inclining downwardly and backwardly from one or more openings in the front end at the top. These fire-bars are set at or about the angle of repose of the material to be burned; that is to say, the fire-bars are set at such an incline as would be formed by the sides of stacks of said material upon the ground.

My improvements in flues consist in a series of secondary flues placed within the main flues (which latter carry the fire gasses or products of combustion) to the chimney. These secondary flues have a regulating door, which allows communication with the atmosphere at their one end, while the other end communicates with the furnace below the fire-bars, and with chambers which have adjustable openings into the furnace above the fire-bars.

The boiler which I prefer to use is a longitudinal combined flue and tubular boiler, set in brickwork or masonry, and the furnace is built in front of the flue or combustion chamber. The flues commence at the back end, are formed in the setting, and direct the fire gasses or products of combustion under the shell of the boiler to the front end, the said fire gasses in their passage passing around and along and heating a series of pipes, tubes, or secondary flues, which are placed in the bottom main flue. The draught from the front end of said bottom flue is upwards, and then back along the top of the boiler, within a flue formed by the top of the setting, and by that portion of the shell of the boiler covering the steam space.

But in order that my invention may be clearly understood, I will now describe the same with reference to my drawings hereto attached, in which figure I is a sectional elevation of a boiler specially designed in accordance with my invention for burning cane trash or "megasse"; figure II is a sectional plan of the same; and figures III and IV are sections on the lines *bb* and *aa* respectively in figure I. The direction of the draught or line of travel of the fire gasses or products of combustion is shown by full arrows, and that of the body of heated air distributed in the furnace by dotted arrows. A is the boiler, B the furnace, C the combustion chamber, D the bottom main flue, and E the secondary flues, in this case formed of wrought-iron pipes or tubes. A¹A² is the brickwork setting; A³ closed air chambers, to form non-conductors of heat; and A⁴ supports for the boiler. B¹B¹ are the feeding openings in the furnace, having dividing plates B²; B³B³ are front set of fire-bars; and B⁴B⁴ the back set. The front ones, B³, are set at the angle of repose of the cane trash, and the back ones, B⁴, at a lesser angle, so that the ashes will fall through, namely, they are set at angles of 47° and 35° respectively, which angles I have found to be the best for this kind of fuel. B⁵ is centre C-shaped bearer for fire-bars; B⁶ is feeding platform; and B⁷ ash-pit. C¹C¹ are galloway tubes, and C²C² longitudinal tubes. D¹D¹ are up-flues; D² top flue; and D³ flue to chimney. E¹E¹ are regulating doors; E² discharge end of secondary flues into furnace; E³ entrance to chambers; E⁴ and E⁵ dampers to furnace; E⁶E⁶ are handles. Cleaning doors for ash-pit, flues, &c., are made where required, as is well understood.

In operation the cane trash or "megasse" is stacked on platform B⁶, closing the openings B¹, to which and through which the stoker pushes it, the dividing plates B² allowing him to regulate the supply, so that it completely blocks the openings, and gradually slides down fire-bars B³ and B⁴, and as it is burned the ashes fall into pit B⁷. The fire gasses or products of combustion pass from chamber C through tubes C² and flues D, D¹, D², and D³ to the chimney (not shown), and while passing through flue D heat the secondary flues or pipes E, causing the air therein to become heated, and while passing through flue D² superheat the steam in the boiler. Air entering through regulated doors E¹, passes through and becomes heated in pipes E, passes at E³ into the furnace below the fire-bars, and a portion of it is drawn through openings E⁴ into chambers E⁴, and is distributed in the burning material by means of C-shaped bearer B⁵, and a regulated quantity of it allowed to enter the furnace above the fire-bars, and burning fuel through dampers E⁵. This supply of heated air entering below, at, and above the fire-bars enables the fuel to be thoroughly consumed, and only just such sufficient quantity is allowed to be distributed as is required for the combustion of the fuel, and to consume the smoke which takes place upon the fire-bars B³B⁴ and in the chamber C. The doors E¹ and dampers E⁵ are regulated, as taught by experience, to allow the proper quantity of air to enter and be distributed.

Having thus fully described and ascertained my said invention, and the manner in which the same is to be performed, I would have it understood that I do not confine myself to any particular kind of boiler, nor to the precise means of carrying out my invention, so long as the nature thereof be retained, but what I believe to be new, and therefore claim as my improvements in furnaces and flues of and for steam-engine boilers is—

- First—A furnace having fire-bars inclining downwardly and backwardly from one or more openings in the front at the top, substantially as herein described and explained.
- Second—Placing a series of secondary flues, tubes, or pipes, communicating with the atmosphere, and with the furnace within the main flues, substantially as herein described and explained.
- Third—The combination and arrangement of the C-shaped bearer B⁵ for the fire-bars, with the secondary flues, substantially as herein described and explained, and as illustrated in my drawings.

Fourth—

Improvements in Furnaces, &c.

Fourth—The combination and arrangement of the parts marked E, E¹, E², E³, and E⁴ with the furnace B, substantially as herein described and explained, and as illustrated in my drawings.

Fifth—The combination and arrangement of the boiler A and flues D, D¹, D², and D³ with the parts specified in the preceding claim, substantially as herein described and explained, and as illustrated in my drawings.

In witness whereof, I, the said Adolph Herzog, have hereto set my hand and seal, this twelfth day of October, one thousand eight hundred and eighty-three.

A. HERZOG.

Witness—

FRED. WALSH,
Manager for Edward Waters' Patent Office, Sydney.

This is the specification referred to in the annexed Letters of Registration granted to Adolph Herzog, this 4th day of January, A.D. 1884.

AUGUSTUS LOFTUS.

REPORT.

Sir,

We do ourselves the honor to report, in reply to your blank cover transmitting Adolph Herzog's petition for the registration of "Improvements in Furnaces and Flues of and for Steam-engine Boilers," that we are of opinion the prayer of the petitioner may be granted in terms of his specification, drawings, and claim.

Sydney, 22 October, 1883.

We have, &c.

GOTHER K. MANN.
JAMES BARNET.

The Under Secretary of Justice.

[Drawings—one sheet.]

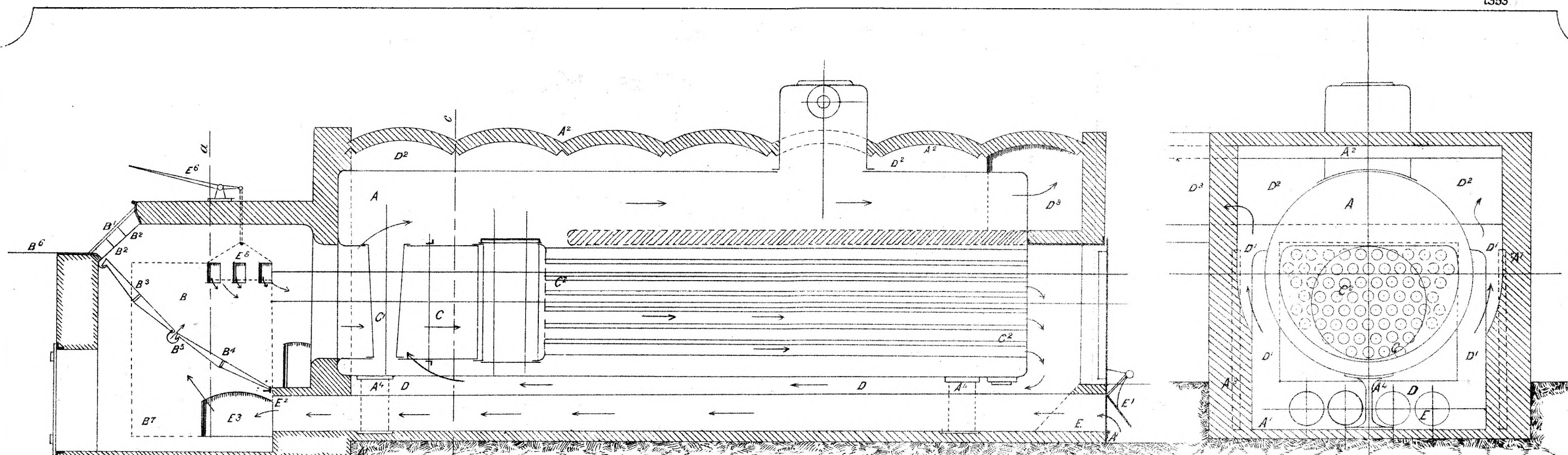


Fig. I.

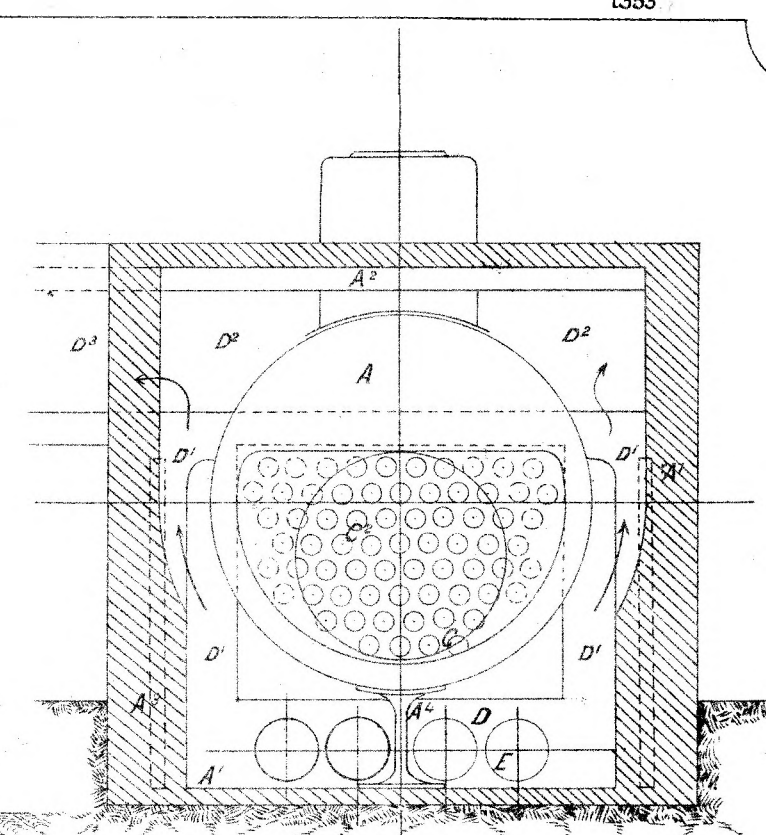


Fig. III. Section C.C.

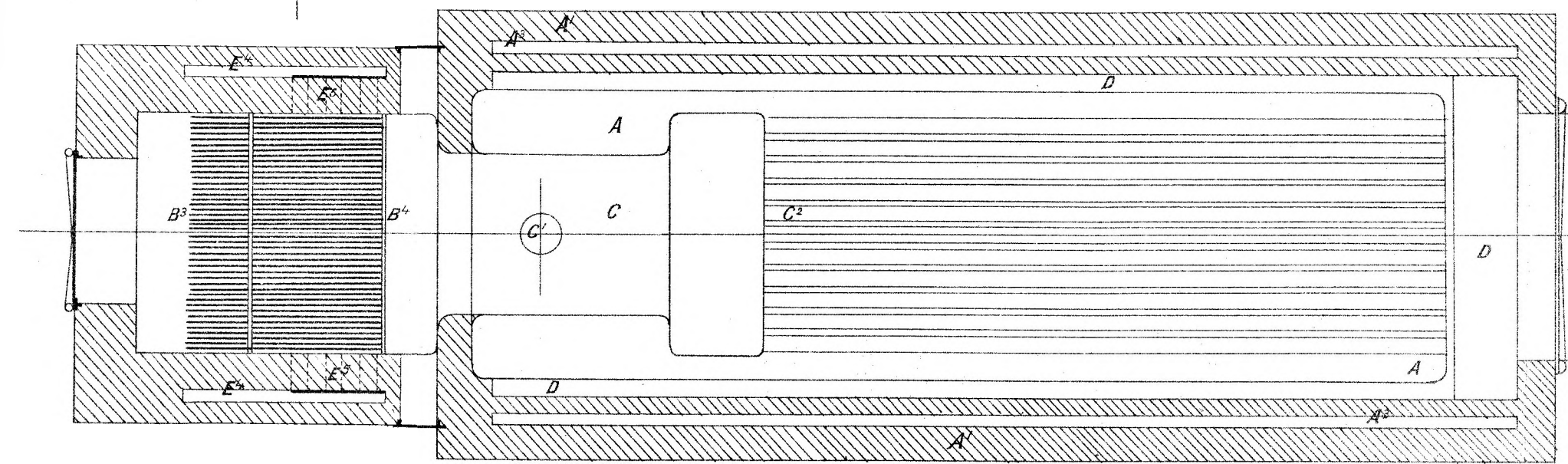


Fig. II.

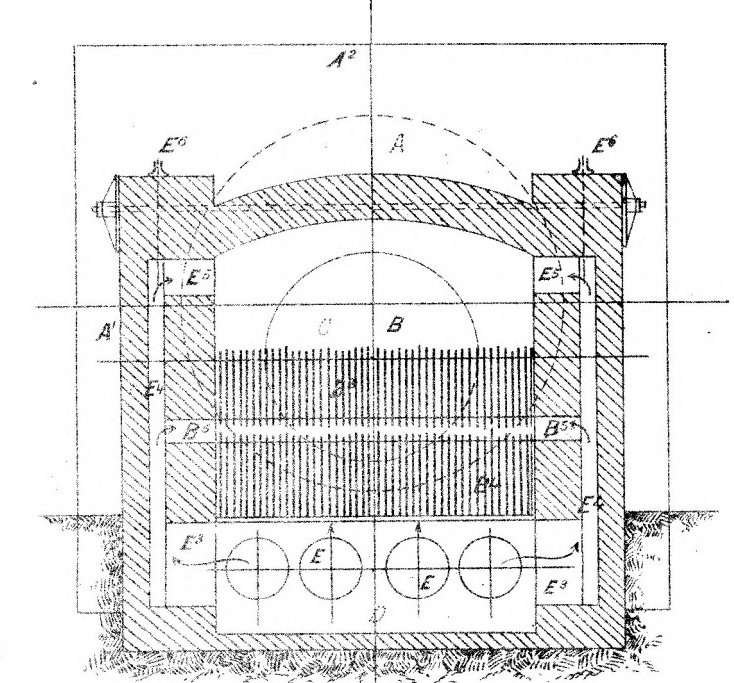


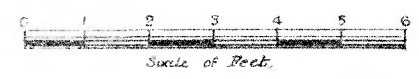
Fig. IV. Section aa.

This is the Sheet of Drawings referred to in the annexed
 Letters of Registration granted to Adolph Herzog, the
 4th day of January A.D. 1884.
 Augustus Loftus.

BOILER FURNACE FOR CANE MEGASS

OCT. 1885

A. HERZOG.



(Sig 246 -)



A.D. 1884, 4th January. No. 1354.

THE NONPAREIL TREE AND STUMP EXTRACTOR.

LETTERS OF REGISTRATION to Henry Williams Treloar, for an Invention entitled "The Nonpareil Tree and Stump Extractor."

[Registered on the 4th day of January, 1884, in pursuance of the Act 16 Vic. No. 24.]

BY HIS EXCELLENCY THE RIGHT HONORABLE SIR AUGUSTUS WILLIAM FREDERICK SPENCER LOFTUS (commonly called LORD AUGUSTUS LOFTUS), Knight Grand Cross of the Most Honorable Order of the Bath, a Member of Her Majesty's Most Honorable Privy Council, Governor and Commander-in-Chief of the Colony of New South Wales and its Dependencies.

TO ALL TO WHOM THESE PRESENTS SHALL COME, greeting :

WHEREAS HENRY WILLIAMS TRELOAR, of Tarnagulla, in the Colony of Victoria, agricultural implement manufacturer, hath by his Petition humbly represented to me that he is the author or designer of a certain invention or improvement in manufactures, that is to say, of an invention entitled "The Nonpareil Tree and Stump Extractor," which is more particularly described in the specification and the sheet of drawings which are hereunto annexed ; and that he, the said Petitioner, hath deposited with the Honorable the Treasurer of the said Colony of New South Wales the sum of Twenty Pounds sterling, for defraying the expense of granting these Letters of Registration, as required by the Act of Council, sixteenth Victoria, number twenty-four ; and hath humbly prayed that I would be pleased to grant Letters of Registration, whereby the exclusive enjoyment and advantage of the said invention or improvement might be secured to him for a period of fourteen years : And I, being willing to give encouragement to all inventions and improvements in the arts or manufactures which may be for the public good, and having received a report favourable to the prayer of the said Petition, from competent persons appointed by me to examine and consider the matters stated therein and to report thereon for my information, am pleased, with the advice of the Executive Council, and in exercise of the power and authority given to me by the said Act of Council, to grant, and do by these Letters of Registration grant unto the said Henry Williams Treloar, his executors, administrators, and assigns, the exclusive enjoyment and advantage of the said invention or improvement, for and during the term of fourteen years from the date hereof ; to have, hold, and exercise unto the said Henry Williams Treloar, his executors, administrators, and assigns, the exclusive enjoyment and advantage thereof, for and during and unto the full end and term of fourteen years from the date of these presents next and immediately ensuing, and fully to be complete and ended : Provided always, that if the said Henry Williams Treloar shall not, within three days after the granting of these Letters of Registration, register the same in the proper office in the Supreme Court, at Sydney, in the the said Colony of New South Wales, then these Letters of Registration, and all advantages whatsoever hereby granted, shall cease and become void.

In witness whereof, I have hereunto set my sign manual, and have caused the present Letters of Registration to be sealed with the seal of the said Colony of New South Wales, at Government House, Sydney, in New South Wales, this fourth day of January, in the year of our Lord one thousand eight hundred and eighty-four.

[L.S.]

AUGUSTUS LOFTUS.

The Nonpareil Tree and Stump Extractor.

SPECIFICATION of the invention of MR. HENRY WILLIAMS TRELOAR, of Tarnagulla, in the Colony of Victoria, agricultural implement manufacturer.

A MACHINE to be employed for the purpose of pulling trees and stumps out of the ground. The said machine to be titled "The Nonpareil Tree and Stump Extractor."

General description.—The machine consists of a double fulcrum lever, perforated straining plate, self-adjusting pins, and a contrivance for the purpose of taking up the slack, and a ladder to assist in the application of the machine.

The Lever.—The lever, which may be of any given length, is constructed as follows, viz.:—At one end is fixed an iron mounting, fig. B in the accompanying drawing, through or in which is a slot, fig. 3, 1 foot in length, $\frac{3}{4}$ inch in width, through which the straining plate, fig. X, passes, above and below the slot, fig. 3, on the mounting B, is welded two studs, fig. C C, $1\frac{1}{4}$ inch in diameter and 3 inches high. Nine inches on each side of the studs, figs. C C, are fixed two shackles at figs. D D. Through the mounting two holes are bored, fig. P P, 1 inch in diameter, which act as guides for the adjusting pins, figs. 4 4.

The iron mounting B is bolted to a piece of wood A, 14 feet (more or less) in length, 4 inches wide, and 3 inches in thickness, with four screw-bolts and nuts.

Wheel at end of lever.—At the end of the wooden lever A, nearest the iron mounting B, is fixed a small wheel, fig. Z.

Means of taking up slack.—The slack of the connection between the anchorage and the tree or stump to be pulled down will be taken up by means of two steel wire ropes with a large hook at each end, as shown in figure K. The hooks at one end will be hooked into the shackles at D D. The hooks on the other ends will be hooked into a 6-inch link-chain 11 feet long. By alternate movements of the lever on the pins 4 4, a 6-inch link will be gained by each movement, and the slack quickly tightened up.

Straining-plate.—The straining-plate X consists of a plate of iron, 10 feet in length, 5 inches in width, and $\frac{1}{2}$ inch in thickness. This plate is perforated, as indicated, with holes, 1 inch in diameter, 2 inches apart, and standing at a right angle to each other.

At the end nearest the anchorage is fixed a shackle, bolted to the plate by means of a $\frac{3}{8}$ screw-bolt and nut.

Connections.—The connections consist of two $\frac{3}{8}$ bars of iron, fig. P, passing one above and the other below the straining-plate X, and fastened to the lever at the mounting B, by dropping fig. O on the studs C C, and inserting a split pin in holes made in the top of the studs C C, to keep fig. O in position.

At the ends of the bars P, denoted by the letter M, will be connected the 6-inch link-chain, 11 feet long, hereinbefore referred to, by means of a screw-bolt and nut passing through the two bars, with the link-chain in the middle. To the link-chain may be hooked as many bars as may be required, similar to the bar, fig. S.

Around the tree to be pulled down will be fixed a strong chain, the bars S hooked to it, the slack taken up as hereinbefore described, and then two or more men, a horse, or bullocks, may be employed as the motive power to move the lever A backwards and forwards; by so doing the lever clears a hole by each such movement. On the plate X, by removing one of the pins relieved by each movement of the lever, and replacing it in another hole, the lever will gradually work along the plate X until the tree or stump is extracted.

Self-adjusting pins.—The pins are lifted in and out of gear by means of two iron-rod keys or eccentrics, running parallel with and fastened to the lever A, with small staples, as shown by fig. H.

The key or eccentric is formed as shown by fig. G G. Fig. E shows the pin-holder, and fig. D 2 the pin. Fig. C 2 shows guide-plate for pins, which is fastened on to the lever end B by means of two set screws 1.

Ladder.—A ladder, 20 feet in length, with pine sides and $\frac{3}{4}$ inch iron rungs is provided, for the purpose of assisting in the application of the machine.

Specialities.—I claim as specialities the manner in which the pins are lifted and replaced in position, the manner in which the slack is taken up, also the 6-inch link-chain, 11 feet long, and the small wheel at the end of the lever to carry its weight.

ERRATA.

Self-adjusting pins.—Fig. F F, in accompanying drawing, shows the studs or supports for the pin-lifters, figs. 4 4, and also supports or bearers for the keys or eccentrics G G.

H. W. TRELOAR.

By his Agent—D. J. DUGGAN.

This is the specification referred to in the annexed Letters of Registration granted to Henry Williams Treloar, the fourth day of January, A.D. 1884.

AUGUSTUS LOFTUS.

REPORT.

Sir,

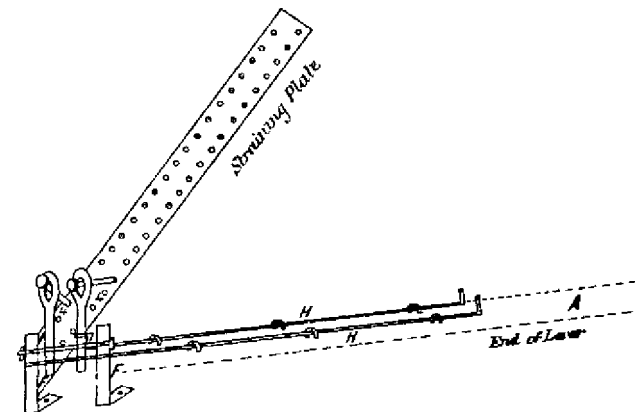
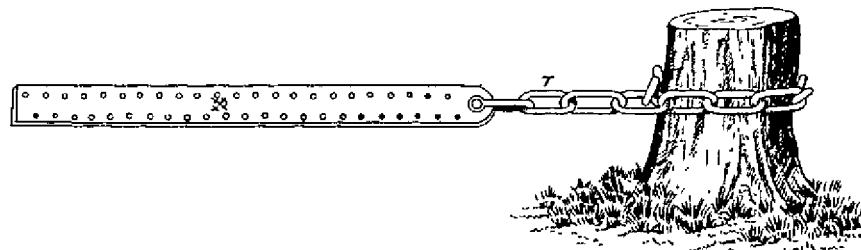
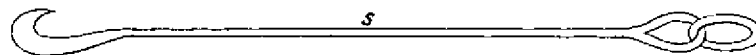
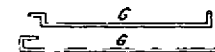
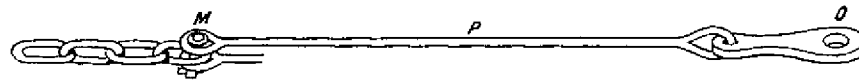
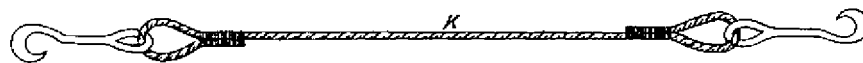
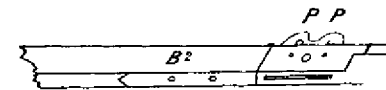
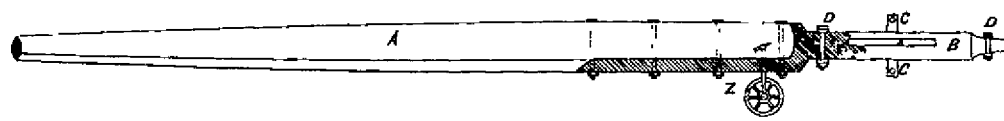
Having examined the specification and sketches accompanying the Petition, we have the honor to recommend that Letters of Registration be issued to Mr. H. W. Treloar for the invention entitled "Tree and Stump Extractor," as described and shown in the specification and sketches attached to the Petition.

The Under Secretary of Justice.

Sydney, 8 October, 1883.

We have, &c.,

JAMES BARNET.
EDMUND FOSBERY.



*This is the Sheet of Drawings referred to in the annexed
Letters of Registration granted to Henry Williams Treloar, the
fourth day of January, A.D. 1884.*

Augustus Loftus.

*W. H. Treloar & Co.
By his agent A. P. [Signature]*



A.D. 1884, 4th January. No. 1355.

AN IMPROVED SELF-ACTING SPRING PAD TRUSS.

LETTERS OF REGISTRATION to Thomas Evans, for an Improved Self-acting Spring Pad Truss.

[Registered on the 4th day of January, 1884, in pursuance of the Act 16 Vic. No. 24.]

BY HIS EXCELLENCY THE RIGHT HONORABLE SIR AUGUSTUS WILLIAM FREDERICK SPENCER LOFTUS (commonly called LORD AUGUSTUS LOFTUS), Knight Grand Cross of the Most Honorable Order of the Bath, a Member of Her Majesty's Most Honorable Privy Council, Governor and Commander-in-Chief of the Colony of New South Wales and its Dependencies.

TO ALL TO WHOM THESE PRESENTS SHALL COME, greeting :

WHEREAS THOMAS EVANS, of Yass, in the Colony of New South Wales, watchmaker and jeweller, hath by his Petition humbly represented to me that he is the author or designer of a certain invention or improvement in manufactures, that is to say, of an invention entitled "An Improved Self-acting Spring Pad Truss," which is more particularly described in the specification and the sheet of drawings which are hereunto annexed; and that he, the said Petitioner, hath deposited with the Honorable the Treasurer of the said Colony of New South Wales, the sum of Twenty Pounds sterling for defraying the expense of granting these Letters of Registration, as required by the Act of Council, sixteenth Victoria, number twenty-four; and hath humbly prayed that I would be pleased to grant Letters of Registration, whereby the exclusive enjoyment and advantage of the said invention or improvement might be secured to him for a period of fourteen years: And I, being willing to give encouragement to all inventions and improvements in the arts or manufactures which may be for the public good, and having received a report favourable to the prayer of the said Petition from competent persons appointed by me to examine and consider the matters stated therein and to report thereon for my information, am pleased, with the advice of the Executive Council, and in exercise of the power and authority given to me by the said Act of Council, to grant, and do by these Letters of Registration grant unto the said Thomas Evans, his executors, administrators, and assigns, the exclusive enjoyment and advantage of the said invention or improvement, for and during the term of fourteen years from the date hereof; to have, hold, and exercise unto the said Thomas Evans, his executors, administrators, and assigns, the exclusive enjoyment and advantage thereof, for and during and unto the full end and term of fourteen years from the date of these presents next and immediately ensuing, and fully to be complete and ended: Provided always, that if the said Thomas Evans shall not, within three days after the granting of these Letters of Registration, register the same in the proper office in the Supreme Court, at Sydney, in the said Colony of New South Wales, then these Letters of Registration, and all advantages whatsoever hereby granted, shall cease and become void.

In witness whereof, I have hereto set my sign manual, and have caused the present Letters of Registration to be sealed with the seal of the said Colony of New South Wales, at Government House, Sydney, in New South Wales, this fourth day of January, in the year of our Lord one thousand eight hundred and eighty-four.

[I.S.]

AUGUSTUS LOFTUS.

An Improved Self-acting Spring Pad Truss.

TO ALL WHOM IT MAY CONCERN: Be it known that I, THOMAS EVANS, of Yass, New South Wales, have invented "An Improved Self-acting Spring Truss," and in the method of manufacturing the same, of which the following is a specification:—

In order that my invention may be distinctly understood, I will now proceed to refer to the annexed drawings, whereon similar letters indicate similar parts wherever they occur:—

Figure 1 shows the truss with the spring closed.

Figure 2 shows the spring open; A leather, B springs, C screw to remove or replace springs; D shows part for restuffing; E sides where springs fit in; F studs for strap.

Figure 3 a side view of truss, showing pad, marked G.

Having now described my invention, the manner of its operation is as follows:—

Having once placed the truss on the weak part, and being properly adjusted, any muscular exertion—coughing, sneezing, running, or walking—will cause the spring to act, therefore protecting the part the truss is on, and rendering the patient thoroughly safe.

Having now described my invention, and the manner of its operation, I claim as my invention "The improved self-acting spring truss."

THOMAS EVANS,
Watchmaker, Cooma-street, Yass,
New South Wales.

This is the specification referred to in the annexed Letters of Registration granted to Thomas Evans, this fourth day of January, A.D. 1884.

AUGUSTUS LOFTUS.

REPORT.

Sir,

We do ourselves the honor to report, in reply to your blank cover, 4th instant, No. 12,272, enclosing Mr. Thomas Evans' petition for the registration of "An Improved Self-acting Spring Truss," that we are of opinion the prayer of the Petitioner may be granted, in terms of his specification, drawings, and claim.

The Under Secretary of Justice.

Sydney, 12 October, 1883.

We have, &c.,

GOTHER K. MANN.
JAMES BARNET.

[Drawings—one sheet.]

Fig. 1.

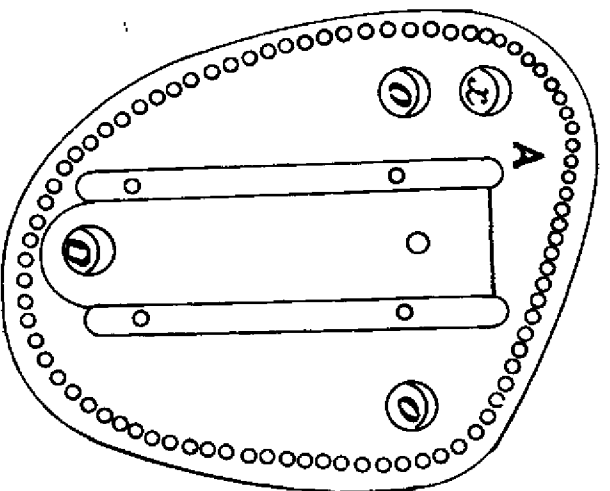


Fig. 2.

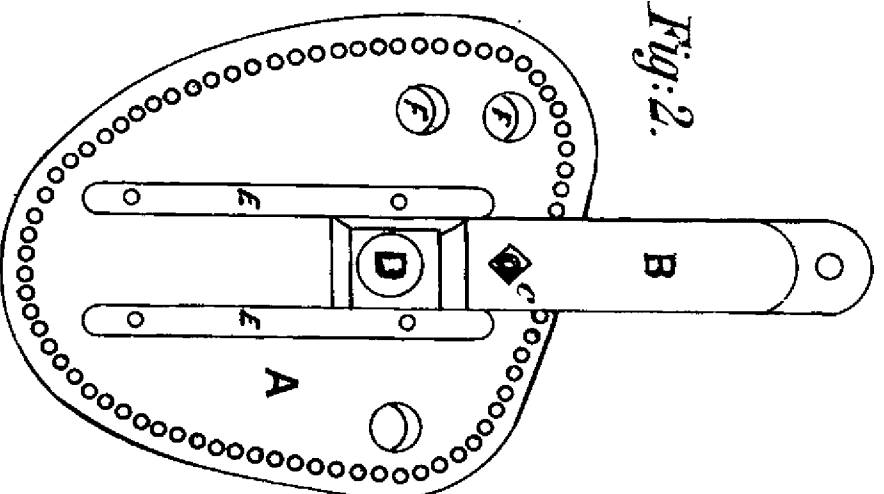
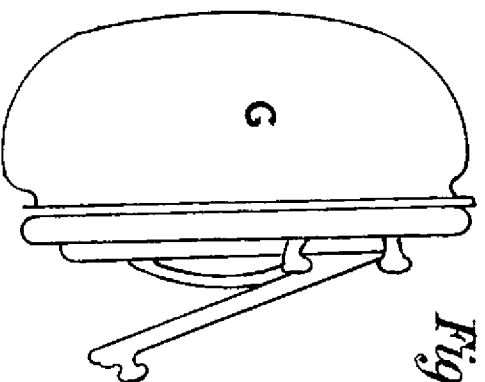


Fig. 3.



This is the Sheet of Drawings referred to in the annexed Letters of Registration, granted to Thomas Evans, the Fourth day of January, A. D., 1884.

Augustus Loftus.



A.D. 1884, 11th January. No. 1356.

MAKING WALLS CONSTRUCTED OF STONE, BRICK, CEMENT, &c., DAMP-PROOF.

LETTERS OF REGISTRATION to William Adam Dixon and Robert Saddington, for Improvements in making Walls constructed of Stone, Brick, Cement, and similar materials Damp-proof.

[Registered on the 11th day of January, 1884, in pursuance of the Act 16 Vic. No. 24.]

BY HIS EXCELLENCY THE RIGHT HONORABLE SIR AUGUSTUS WILLIAM FREDERICK SPENCER LOFTUS (commonly called LORD AUGUSTUS LOFTUS), Knight Grand Cross of the Most Honorable Order of the Bath, a Member of Her Majesty's Most Honorable Privy Council, Governor and Commander-in-Chief of the Colony of New South Wales and its Dependencies.

TO ALL TO WHOM THESE PRESENTS SHALL COME, greeting :

WHEREAS WILLIAM ADAM DIXON, of the Technical Colloge, Pitt-street, Sydney, chemist, and ROBERT SADDINGTON, Chairman of the Australian Kerosene Oil and Mineral Company, of No. 3, Gresham-street, in the City of Sydney, and Colony of New South Wales, have by their Petition humbly represented to me that they are the authors or designers of a certain invention or improvement in manufactures, that is to say, of an invention for "Making Walls constructed of Stone, Brick, Cement, and similar materials Damp-proof," which is more particularly described in the specification which is hereunto annexed; and that they, the said Petitioners, have deposited with the Honorable the Treasurer of the said Colony of New South Wales the sum of Twenty Pounds sterling, for defraying the expenso of granting these Letters of Registration, as required by the Act of Council, sixteenth Victoria, number twenty-four; and have humbly prayed that I would be pleased to grant Letters of Registration, whereby the exclusive enjoyment and advantage of the said invention or improvement might be secured to them for a period of fourteen years: And I, being willing to give encouragement to all inventions and improvements in the arts or manufactures which may be for the public good, and having received a report favourable to the prayer of the said Petition, from competent persons appointed by me to examine and consider the matters stated therein and to report thereon for my information, am pleased, with the advice of the Executive Council, and in exercise of the power and authority given to me by the said Act of Council, to grant, and do by these Letters of Registration grant unto the said William Adam Dixon and Robert Saddington, their executors, administrators, and assigns, the exclusive enjoyment and advantage of the said invention or improvement, for and during the term of fourteen years from the date hereof; to have, hold, and exercise unto the said William Adam Dixon and Robert Saddington, their executors, administrators, and assigns, the exclusive enjoyment and advantage thereof, for and during and unto the full end and term of fourteen years from the date of these presents next and immediately ensuing, and fully to be complete and ended: Provided always, that if the said William Adam Dixon and Robert Saddington shall not, within three days after the granting of these Letters of Registration, register the same in the proper office in the Supreme Court, at Sydney, in the said Colony of New South Wales, then these Letters of Registration, and all advantages whatsoever hereby granted shall cease and become void.

In witness whereof, I have hereunto set my sign manual, and have caused the present Letters of Registration to be sealed with the seal of the said Colony of New South Wales, at Government House, Sydney, in New South Wales, this eleventh day of January, in the year of our Lord one thousand eight hundred and eighty-four.

[L.S.]

AUGUSTUS LOFTUS

Making Walls constructed of Stone, Brick, Cement, &c., Damp-proof.

SPECIFICATION.

WE, WILLIAM ADAM DIXON, of the Technical College, Pitt-street, Sydney, chemist, and ROBERT SADDINGTON, Chairman of the Australian Kerosene Oil and Mineral Company (Limited), of 3, Gresham-street, Sydney, do hereby declare the nature of our invention for making walls constructed of stone, brick, cement, and similar materials damp-proof. Our process has the advantage that whilst the substance used is practically indestructible by any atmospheric influence, and is easily applied, it does not alter the appearance of the surface in the slightest degree. It is also applicable to the interior walls of hospitals to prevent the lodgment of disease germs.

In carrying out our process we dissolve paraffine, preferably refined or semi-refined, in light shale or mineral naphtha, spirit of turpentine, alcohol, or other volatile solvent, and apply the solution with a brush rapidly to the surface to be protected, which surface must be at the time thoroughly dry. The solvent immediately evaporates and leaves the surface particles of the stone covered with a water-repelling coating of paraffine. Generally one coat or application is sufficient, but on very porous stone, or on the upper sides of string courses or other horizontal surfaces, we apply two or three coats. In making the solution we prefer to use shale or mineral naphtha on account of its cheapness, and the strength of solution we prefer is obtained by dissolving one pound of paraffine in one gallon of naphtha. The solution is easily effected by melting the paraffine and pouring it into the naphtha with stirring.

Having now described the nature of our invention, we wish it to be understood that we do not claim the above proportion or any other proportion. Our claim is for rendering stone, brick, or other building material damp-proof by the application of a solution of paraffine, which we carry out as above described. We prefer to apply the solution to walls and buildings already erected.

WILL. A. DIXON.
ROBT. SADDINGTON.

This is the specification referred to in the annexed Letters of Registration granted to William Adam Dixon and Robert Saddington, this eleventh day of January, A.D. 1884.

AUGUSTUS LOFTUS.

REPORT.

Sir,

Sydney, 17 October, 1883.

The application of Messrs. Dixon and Saddington for Letters of Registration for an invention for "rendering walls of bricks, stone, cement, and similar materials damp-proof" having been referred to us, we have examined the specification accompanying the same, and have now the honor to report that we see no objection to the issue of Letters of Registration as prayed for.

We have, &c.,
JAMES BARNET.
E. C. CRACKNELL.

The Under Secretary of Justice.



A.D. 1884, 11th January. No. 1357.

**A NEW OR IMPROVED METHOD OF TREATING MATERIAL COMPOSED OF
VEGETABLE AND ANIMAL MATTER, &c.,**

LETTERS OF REGISTRATION to George Tolson and John Edwin Tolson, for a new or improved method of treating material composed of vegetable and animal matter, whereby the vegetable matter is extracted, and the animal matter dyed; also, for apparatus employed therein.

[Registered on the 11th day of January, 1884, in pursuance of the Act 16 Vic. No. 24.]

BY HIS EXCELLENCY THE RIGHT HONORABLE SIR AUGUSTUS WILLIAM FREDERICK SPENCER LOFTUS (commonly called LORD AUGUSTUS LOFTUS), Knight Grand Cross of the Most Honorable Order of the Bath, a Member of Her Majesty's Most Honorable Privy Council, Governor and Commander-in-Chief of the Colony of New South Wales and its Dependencies.

TO ALL TO WHOM THESE PRESENTS SHALL COME, greeting :

WHEREAS GEORGE TOLSON and JOHN EDWIN TOLSON, both of Dewsbury, in the county of York, England, wool carbonizers, have by their Petition humbly represented to me that they are the authors or designers of a certain invention or improvement in manufactures, that is to say, of an invention entitled "A new or improved method of treating material composed of vegetable and animal matter, whereby the vegetable matter is extracted, and the animal matter dyed; also, for apparatus employed therein," which is more particularly described in the specification and the sheet of drawings which are hereunto annexed; and that they, the said Petitioners, have deposited with the Honorable the Treasurer of the said Colony of New South Wales the sum of Twenty Pounds sterling, for defraying the expense of granting these Letters of Registration, as required by the Act of Council, sixteenth Victoria, number twenty-four; and have humbly prayed that I would be pleased to grant Letters of Registration, whereby the exclusive enjoyment and advantage of the said invention or improvement might be secured to them for a period of fourteen years: And I, being willing to give encouragement to all inventions and improvements in the arts or manufactures which may be for the public good, and having received a report favourable to the prayer of the said Petition, from competent persons appointed by me to examine and consider the matters stated therein and to report thereon for my information, am pleased, with the advice of the Executive Council, and in exercise of the power and authority given to me by the said Act of Council, to grant, and do by these Letters of Registration grant unto the said George Tolson and John Edwin Tolson, their executors, administrators, and assigns, the exclusive enjoyment and advantage of the said invention or improvement, for and during the term of fourteen years from the date hereof; to have, hold, and exercise unto the said George Tolson and John Edwin Tolson, their executors, administrators, and assigns, the exclusive enjoyment and advantage thereof, for and during and unto the full end and term of fourteen years from the date of these presents next and immediately ensuing, and fully to be complete and ended: Provided always, that if the said George Tolson and John Edwin Tolson shall not, within three days after the granting of these Letters of Registration, register the same in the proper office in the Supreme Court, at Sydney, in the said Colony of New South Wales, then these Letters of Registration, and all advantages whatsoever hereby granted, shall cease and become void.

In witness whereof, I have hereunto set my sign manual, and have caused the present Letters of Registration to be sealed with the seal of the said Colony of New South Wales, at Government House, Sydney, in New South Wales, this eleventh day of January, in the year of our Lord one thousand eight hundred and eighty-four.

[r.s.]

AUGUSTUS LOFTUS.

A new or improved method of treating material composed of vegetable & animal matter.

SPECIFICATION of George Tolson and John Edwin Tolson, both of Dewsbury, in the county of York, England, wool carbonizers, for an invention entitled "A New or Improved Method of treating material composed of vegetable and animal matter, whereby the vegetable matter is extracted, and the animal matter dyed; also, for apparatus employed therein."

THIS invention relates to a new method of disintegrating or effecting the separation of vegetable matter from the animal matter in material composed of a mixture of such substances, such invention being principally applicable to mixtures of cotton and wool, or woollen fibres.

The apparatus employed in carrying out this process consists of a revolving tank, in which the material is placed, and underneath which is a fire or steam-heating apparatus for keeping the same at the required temperature. Within the tank are fixed prongs, agitators, for the purpose of breaking up and distributing the fibre, so that it is more thoroughly exposed to the action of the gases. A door is made at each corner of the revolving tank for introducing the fibre, and when desirable the tank is lined with wire netting, and the door may be left open, so that the workmen can ascertain how the fibre is going on. In connection with the revolving tank is a retort or still, for the manufacture of the gases requisite for carrying out the operation.

In order that the invention may be more fully understood, we have hereto annexed a sheet of drawings illustrative thereof, where fig. 1 is elevation of the apparatus, showing the tank in section, and fig. 2 is cross-section of the said tank. A is the revolving tank or receiver, having hollow axes or bushes B, on which are formed discs C. The tank revolves upon the friction pulleys D, which are supported by the masonry E. F is the driving pulley, mounted on the shaft G, which passes through a metal bearing H, and is secured within the bush B. J are a number of prongs or forks, employed for the purpose of lifting the fibre, as shown in fig. 2, whereby the fibre is kept in constant agitation so long as the tank is revolving. K is a retort or still, which is charged or filled from the top side, and communicates with the tank by means of the pipe L, which is enamelled on the inner surface to prevent the injurious effect of the acids thereon. Each corner of the tank is provided with a door N, hinged at a, through which the fibre is introduced and removed; and when desirable the tank may be lined with wire netting or gauze, as shown at P in fig. 2.

The tank may be heated either by fire or steam pipes M. The material to be disintegrated is placed in the tank, which is then hermetically sealed, and heated sufficiently to prevent the gases introduced thereto from condensing. The retort is then charged with equal quantities of sulphuric acid and chloride of sodium or common salt, and the gas evolved passes into the tank and destroys the vegetable matter contained in the materials under operation. After a period, varying from twenty to forty minutes, the disintegration is generally complete, and the material may be removed from the tank and shaken, for the purpose of getting rid of the refuse vegetable matter. To neutralize the acid gas remaining in the woollen material is placed in the tank, as before, and the gas arising from the distillation of silicate of ammonia, or substances containing the elements thereof, is passed into the tank. It is better to prepare this gas in a separate still or retort, heated by a steam jet and provided with an agitator, the gas being conveyed to the tank by a leaden pipe connected with the pipe L.

The material may then be dyed by placing in the retort a mixture of common salt and nitrate of soda, to which may be added picric acid, bichromate, or other salts of potassium, and aniline crystals containing colouring matter.

We claim,—

Firstly—The method of, and apparatus for, disintegrating materials composed of vegetable and animal fibres, neutralizing the acid remaining in the animal portion, and dyeing the same by the action of dry gases, as herein shown and described.

Secondly—The use and employment of the prongs or forks J for the purpose of agitating the fibre, as described.

Thirdly—The use and employment of the wire netting N for purposes as described.

In witness whereof, we, the said George Tolson and John Edwin Tolson, have hereunto set our hands and seals, this eighteenth day of July, 1883.

Witness—
C. TOLSON.

GEORGE TOLSON.
JOHN EDWIN TOLSON.

This is the specification referred to in the annexed Letters of Registration granted to George Tolson and John Edwin Tolson, this eleventh day of January, A.D. 1884.

AUGUSTUS LOFTUS.

REPORT.

Sir,

Sydney, 15 September, 1883.

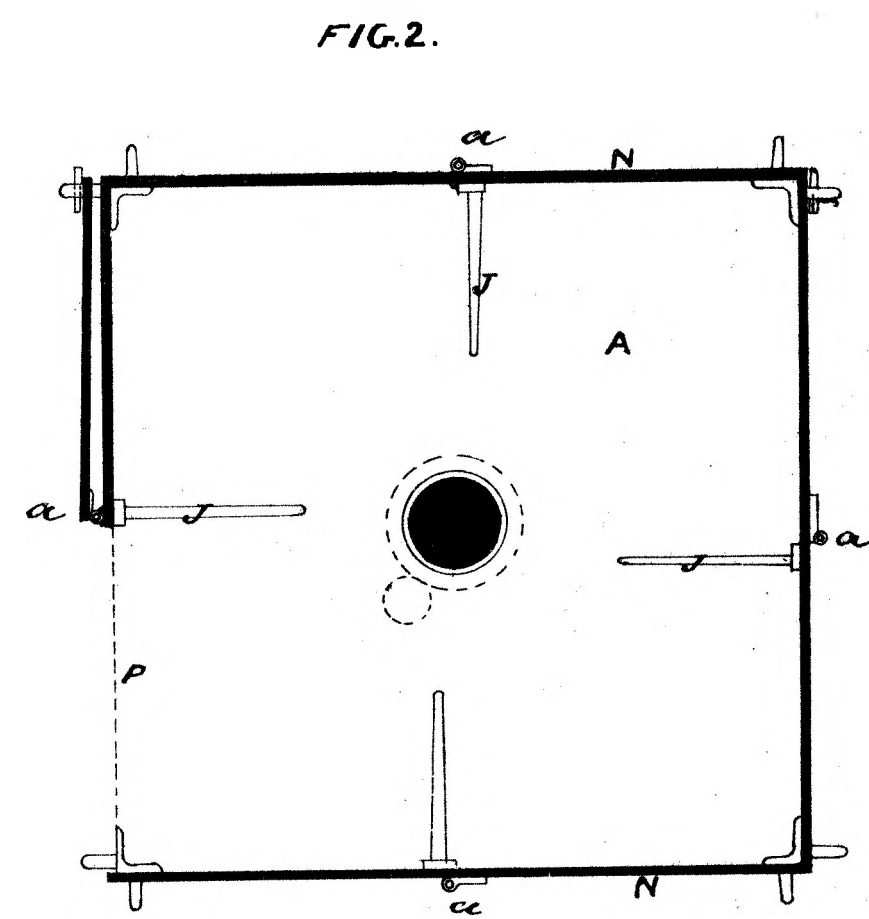
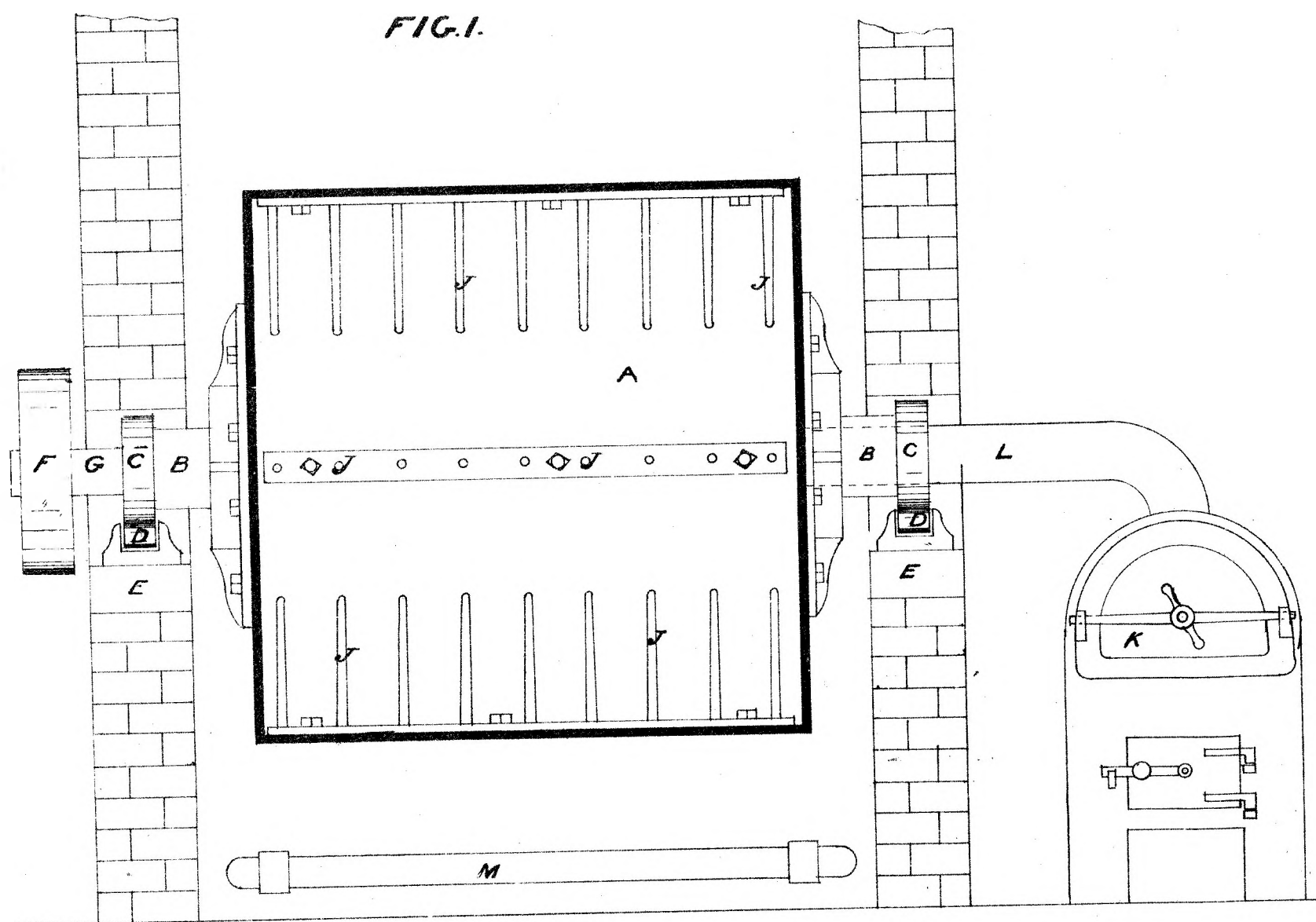
In the matter of the application of Messrs. George and John E. Tolson for Letters of Registration for "A new or improved method of treating material composed of vegetable and animal matter, &c.," we have examined the specification and drawings accompanying the same, and have now the honor to report that we see no objection to the issue of Letters of Registration, as prayed for.

There is some obscurity in the reference to a "gas arising from the distillation of silicate of ammonia," and we think it probable that the word "silicate" has been accidentally substituted for some other word; but, as the substance is not specially claimed, we do not think that this possible mistake need stand in the way of the specification being passed.

We have, &c.,
J. SMITH.
CHS. WATT.

The Under Secretary of Justice.

[Drawings—one sheet.]



*This is the Sheet of Drawings referred to in the annexed
Letters of Registration granted to George Tolson, and John
Edwin Tolson, this eleventh day of January, AD, 1884.
Augustus Loftus.*

(Sig 245-)



A.D. 1884, 11th January. No. 1358.

IMPROVED MACHINE FOR TWISTING OR SPINNING AND REELING WIRE.

LETTERS OF REGISTRATION to Colin Mackay, Henry Walden, and Henry North, for an Improved Machine for Twisting or Spinning and Reeling Wire.

[Registered on the 11th day of January, 1884, in pursuance of the Act 16 Vic. No. 24.]

BY HIS EXCELLENCY THE RIGHT HONORABLE SIR AUGUSTUS WILLIAM FREDERICK SPENCER LOFTUS (commonly called LORD AUGUSTUS LOFTUS), Knight Grand Cross of the Most Honorable Order of the Bath, a Member of Her Majesty's Most Honorable Privy Council, Governor and Commander-in-Chief of the Colony of New South Wales and its Dependencies.

TO ALL TO WHOM THESE PRESENTS SHALL COME, greeting :

WHEREAS COLIN MACKAY, engineer, HENRY WALDEN, merchant, and HENRY NORTH, gentleman, all of Dunedin, in the provincial district of Otago, in the Colony of New Zealand, have by their Petition humbly represented to me that they are the authors or designers of a certain invention or improvement in manufactures, that is to say, of an invention entitled "An improved machine for twisting or spinning and reeling wire," which is more particularly described in the specification and the sheet of drawings which are hereunto annexed ; and that they, the said Petitioners, have deposited with the Honorable the Treasurer of the said Colony of New South Wales the sum of Twenty Pounds sterling, for defraying the expense of granting these Letters of Registration, as required by the Act of Council, sixteenth Victoria, number twenty-four ; and have humbly prayed that I would be pleased to grant Letters of Registration, whereby the exclusive enjoyment and advantage of the said invention or improvement might be secured to them for a period of fourteen years : And I, being willing to give encouragement to all inventions and improvements in the arts or manufactures which may be for the public good, and having received a report favourable to the prayer of the said Petition, from competent persons appointed by me to examine and consider the matters stated therein and to report thereon for my information, am pleased, with the advice of the Executive Council, and in exercise of the power and authority given to me by the said Act of Council, to grant, and do by these Letters of Registration grant unto the said Colin Mackay, Henry Walden, and Henry North, their executors, administrators, and assigns, the exclusive enjoyment and advantage of the said invention or improvement, for and during the term of fourteen years from the date hereof ; to have, hold, and exercise unto the said Colin Mackay, Henry Walden, and Henry North, their executors, administrators, and assigns, the exclusive enjoyment and advantage thereof, for and during and unto the full end and term of fourteen years from the date of these presents next and immediately ensuing, and fully to be complete and ended : Provided always, that if the said Colin Mackay, Henry Walden, and Henry North shall not, within three days after the granting of these Letters of Registration, register the same in the proper office in the Supreme Court, at Sydney, in the said Colony of New South Wales, then these Letters of Registration, and all advantages whatsoever hereby granted, shall cease and become void.

In witness whereof, I have hereunto set my sign manual, and have caused the present Letters of Registration to be sealed with the seal of the said Colony of New South Wales, at Government House, Sydney, in New South Wales, this eleventh day of January, in the year of our Lord one thousand eight hundred and eighty-four.

[L.S.]

AUGUSTUS LOFTUS.

Improved Machine for Twisting or Spinning and Reeling of Wire.

SPECIFICATION of COLIN MACKAY, engineer, HENRY WALDEN, merchant, and HENRY NORTH, gentleman, all of Dunedin, in the provincial district of Otago, in the Colony of New Zealand, for an invention entitled "An Improved Machine for Twisting or Spinning and Reeling Wire."

OUR improved machine for twisting or spinning and reeling wire has been designed for the purpose of twisting or spinning two or more wires together (plain or barbed), and reeling them simultaneously.

Referring to the drawing, figure 1 shows plan, figure 2 side elevation (in which the driving gear is represented by their pitch circles in dotted lines), and figure 3 end elevation (omitting the delivery reels D D for the sake of clearness) of our machine for twisting and reeling wires. Figures 4, 5, and 6 show side, end, and partial top view of the gripping wheel C and attachments. Figure 7 shows section of the bevel gearing for driving the revolving frame E.

The framework of our machine consists of the side frame A, the end distance girders A¹, the two top centre rails or gantry A², and the bottom centre bridge girder A³, all as represented in figures 1, 2, and 3 of our drawings. B B are the driving pulleys, B¹ spur pinion, and B² bevel wheel, all fitted on the shaft B³, which works at the outer end in a bearing in the side frame A, and at the inner end in a bearing formed in the hanging bracket A⁴, attached to the centre rails A², as shown. The spur pinion B¹ gears into spur wheel B⁴, working on movable spindle B⁵, fixed in desired position in the radius slot A⁶, provided in the side frame A. On spindle B⁵ is also the spur pinion B⁶, gearing into spur wheel B⁷ on shaft B⁸, which drives the gripper wheel C, and passes through the spiral tappet C¹, fixed to one of the centre rails A². The outer end of shaft B³ works in a bearing provided in side frame A, and at the other end in bearings formed in the centre rails A². D D are the delivery reels on shaft D¹, working in bearings in the brackets D² projecting from the end distance girder A¹. A⁶ is the tension box, having the pins a therein. The bevel wheel B² gears into another bevel wheel E², which may be formed or fixed on hollow neck or journal E¹, projecting from the revolting frame E. This hollow neck or journal works in a bearing provided in the hanging bracket A⁴. F is the guide wheel on spindle working in bearings formed in brackets F¹, attached to the revolving frame E. G is the receiving reel, which is revolved by and travels on shaft G¹, whose ends work in bearings G², in the side of the revolving frame E. The bottom of revolving frame works on the upright pin E³, bolted to the bottom bridge girder A³. On the upper end of pin E³ is fixed the stationary eccentric E⁴, by which means the lateral or spooling movement and the revolving or winding motion is given to the receiving reel G when the revolving frame E is in motion.

The lateral or spooling movement is given to reel G by reason of the eccentric strap and rod H revolving on the stationary eccentric E⁴, which movement causes the paul H¹ (by the mechanical arrangement shown) to give motion to the upright shaft H² (working in bearings in the revolving frame) through the medium of the ratchet wheel H³. Fixed to the upper end of shaft H² is the worm H⁴, working in tangent wheel H⁵, that imparts motion to the shaft passing through bearing in revolving frame E, and giving motion to the crank disc H⁶, attached by connecting rod H⁷ to the forked lever H⁸, pivoted at E⁵ to the revolving frame and its forked lower end, working between the collars G³, formed on the receiving reel G.

The revolving or winding motion is given to same by reason of the eccentric rod and strap J, with lever J¹ revolving on the stationary eccentric E⁴, and thereby working the rocking crank J², whose horizontal tail is cranked, and works in slot in the bottom of the vertical lever J³, connected to pawl mechanism J⁴, which imparts a rotary motion to the ratchet wheel J⁵, fixed to the shaft G¹ of the receiving reel G. J⁶ is a check pawl to prevent the reel from returning.

Referring now more particularly to figures 4, 5, and 6, in which the gripping wheel C and its parts are shown to a larger scale, it will be noticed that the wires K are gripped firmly during the time that the projecting portion b of the elbow lever C² traverses on the fixed spiral tappet C¹ from e to d, and at which latter point the elbow lever C² will be again released, as shown in figure 6. The elbow levers C² (of which any convenient number may be used) work on pivots C³, fitted in the slots in the gripping wheel C, and grip the wire between them and the fixed lugs C⁴ opposite to them on the gripping wheel C. The gripping wheel C and guide wheel F have barb gaps L shown, which will be necessary when barb wire is being operated upon.

The mode of operation is as follows:—The receiving reels D D¹ having been filled with wire which it is desired to twist, the wires would then be passed through the tension box A⁶, and on to the gripping wheel C, then down through the hole in bevel wheel E², on top of revolving frame E, and over guide wheel F to the receiving reel G, where it is made fast. The machine is then started by motion being imparted to the pulley B, which drives the shaft B³ and the bevel wheels B² and E², thus giving the required rotary motion to the revolving frame E, which in its turn carries the eccentric straps H and J around the stationary eccentric E⁴, thereby giving the required lateral or spooling and winding motion to the receiving reel G, as before described. Simultaneously with the starting of the machine the shaft B³, on which is fixed the gripping wheel C, would be set in motion by the system of gearing hereinbefore described, thereby gripping the wires K, and drawing them through the tension box A⁶, while the wires being made fast on the receiving reel G in the revolving frame E, which is travelling in a plane at right angles to the plane of the gripping wheel C, are consequently twisted or spun and being wound on the receiving reel G simultaneously.

Having thus described the nature of this invention, and the manner of performing same, we would have it understood that the novelties in our improved machine for twisting or spinning and reeling wire, which we claim as of our invention, are:—

First—The gripping wheel C, with its gripping contrivances C² and C⁴, in combination with the stationary spiral tappet C¹, as forming part of our spinning machine.

Second—The revolving frame E, with its hollow journal E¹, guide wheel F, and receiving reel G, all as forming part of our spinning machine.

Third—The combination of the revolving frame E with the stationary eccentric E⁴, and receiving reel G, with the mechanical contrivances for giving the rotary and lateral motion to said receiving reel G, all substantially as described and explained, and as illustrated in the drawings.

Fourth—

Improved Machine for Twisting or Spinning and Reeling Wire.

Fourth—The combination and arrangement of all the parts forming our simultaneous twisting and reeling machine, substantially as herein described and explained, and as illustrated in the drawings.

In witness whereof, we, the said Colin Mackay, Henry Walden, and Henry North have hereto set our hands and seals, this twenty-eighth day of September, one thousand eight hundred and eighty-three.

Witness—

W. S. BAYSTON,
Patent Law Clerk, Melbourne.

COLIN MACKAY.
HENRY WALDEN.
HENRY NORTH.

By their Attorney—
EDWD. WATERS.

This is the specification referred to in the annexed Letters of Registration granted to Colin Mackay, Henry Walden, and Henry North, this 11th day of January, A.D. 1884.

AUGUSTUS LOFTUS.

REPORTS.

Sir,

Sydney, 10 October, 1883.

In reply to your blank cover communication of the 3rd instant, No. 12,115, transmitting the petition of Messrs. Colin Mackay, Henry Walden, and Henry North, for the registration of an invention entitled "An improved machine for twisting or spinning and reeling wire," we do ourselves the honor to report that we are of opinion that the prayer of the petitioners may be granted, in accordance with their specification, drawings, and claim.

Attention is drawn to the fact that the covering letter is signed by Mr. Fred. Walsh, while the copy of petition is not signed at all; also, the specification is signed by Mr. Edward Waters, of Melbourne, as attorney for the applicants, but the receipt is in the name of the applicants, the attorney or agent not being mentioned therein.

We have, &c.,
A. FRASER.
T. RICHARDS.

The Under Secretary of Justice.

Sir,

Sydney, 25 October, 1883.

With reference to your B.C. of the 20th instant, referring to us for further report the petition of Mr. Waters, of Melbourne, praying that Letters of Registration for an invention may issue to certain persons, for whom he is acting as attorney, we do ourselves the honor to report that the petition having now been signed by Mr. Waters, the prayer of the petition may be granted, as already recommended in our report of the 10th instant.

We have, &c.,
A. FRASER.
T. RICHARDS.

The Under Secretary of Justice.

Drawings— one sheet.

MACKAY WALDEN & NORTH'S PATENT

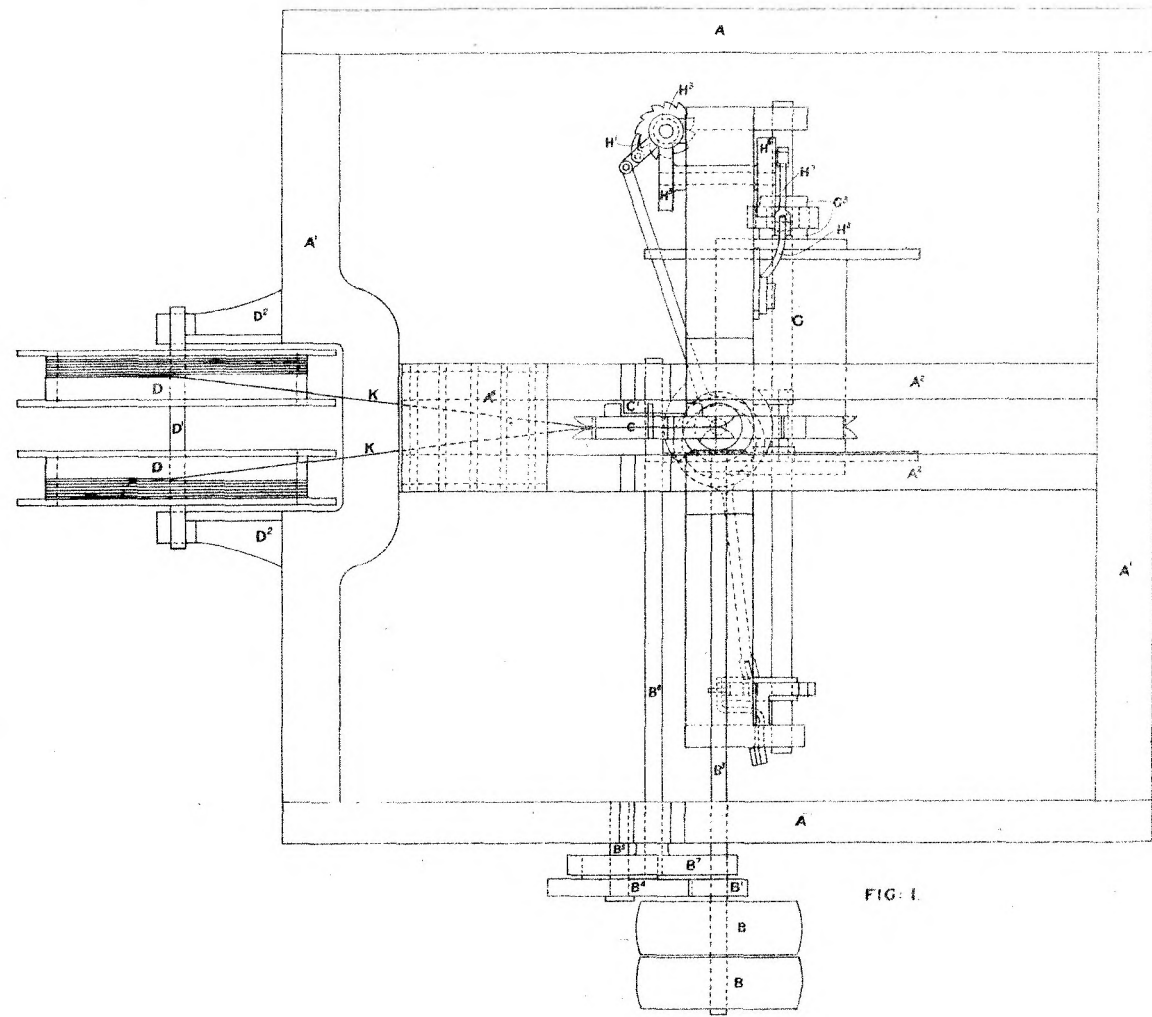


FIG. 1.

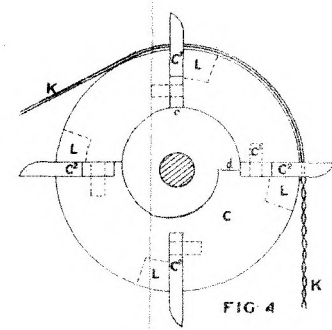


FIG. 4.

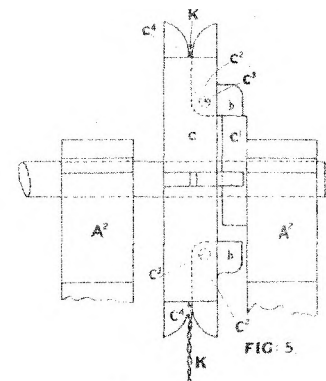


FIG. 5.

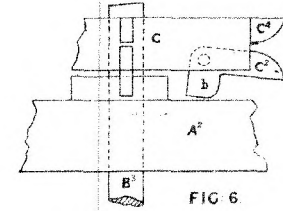


FIG. 6.

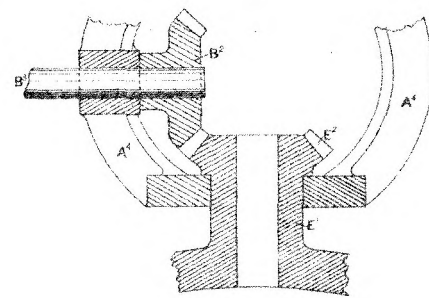


FIG. 7.

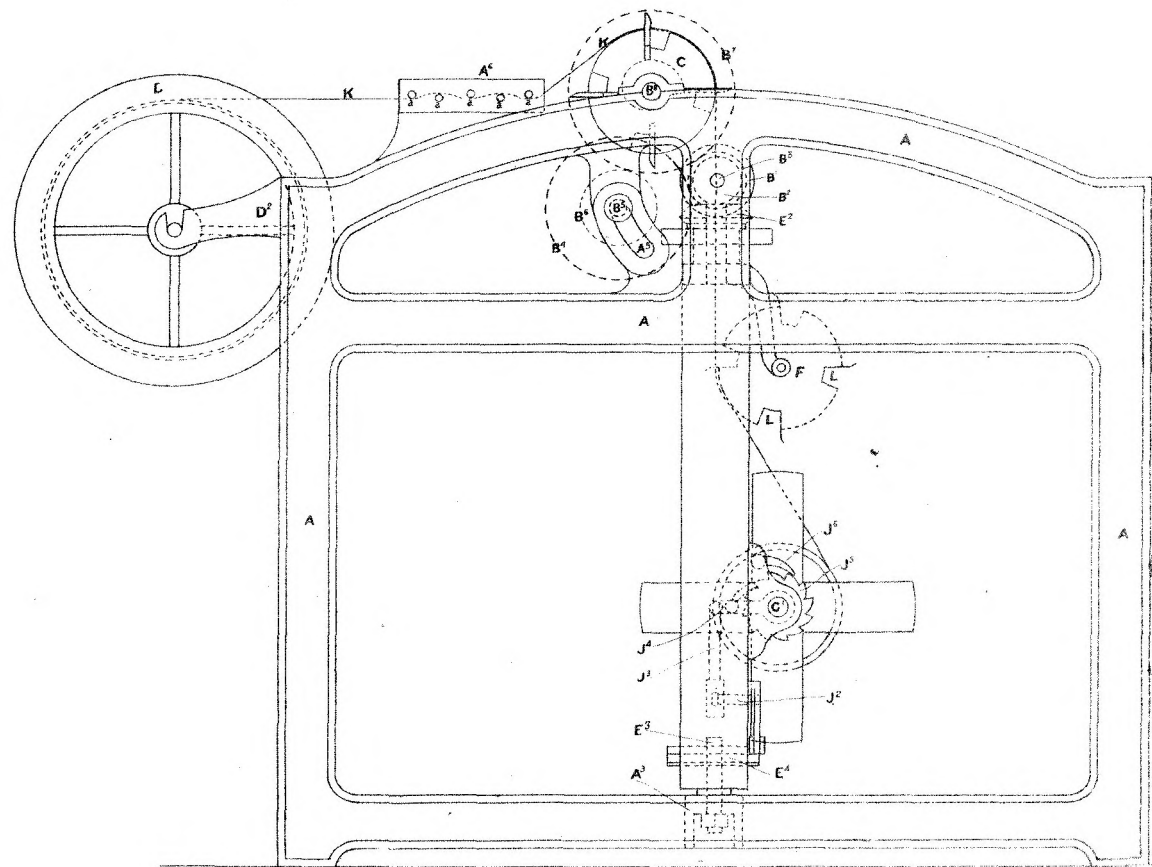


FIG. 2.

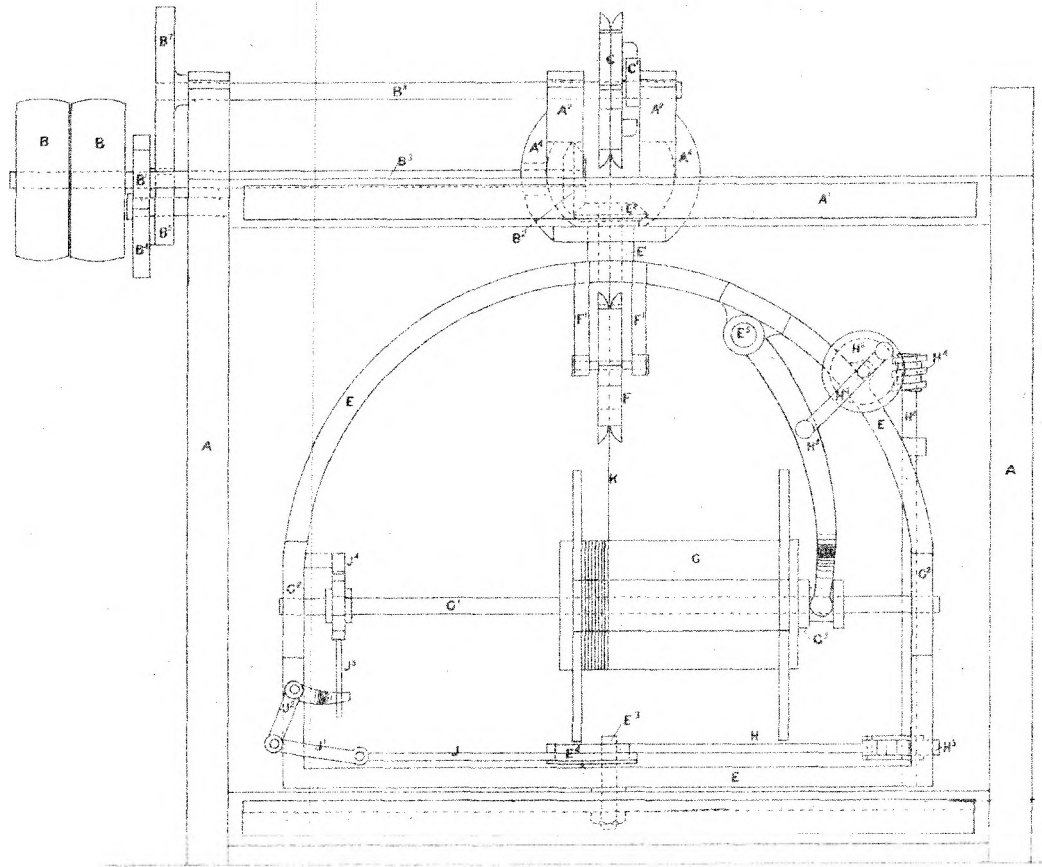


FIG. 3.

This is the Sheet of Drawings referred to in the annexed
 Letters of Registration granted to Colin Mackay, Henry Walden,
 and Henry North, this seventh day of January, AD 1884.

Augustus Loftus.



A.D. 1884, 12th January. No. 1359.

IMPROVEMENTS IN THE METHOD OF EXTRACTING GOLD AND SILVER FROM CERTAIN OF THEIR ORES, &c.

LETTERS OF REGISTRATION to Stephen Osborne and Andrew Thomas, for an improved method of extracting Gold and Silver from certain of their ores, and utilizing some of the other products of the process.

[Registered on the 12th day of January, 1884, in pursuance of the Act 16 Vic. No. 24.]

BY HIS EXCELLENCY THE RIGHT HONORABLE SIR AUGUSTUS WILLIAM FREDERICK SPENCER LOFTUS (commonly called LORD AUGUSTUS LOFTUS), Knight Grand Cross of the Most Honorable Order of the Bath, a Member of Her Majesty's Most Honorable Privy Council, Governor and Commander-in-Chief of the Colony of New South Wales and its Dependencies.

TO ALL TO WHOM THESE PRESENTS SHALL COME, greeting :

WHEREAS STEPHEN OSBORNE, of Buxton-street, North Adelaide, in the province of South Australia, mining engineer, and ANDREW THOMAS, of Grosham-street, Adelaide, in the same province, analytical chemist, have by their Petition humbly represented to me that they are the authors or designers of a certain invention or improvement in manufactures, that is to say, of an invention entitled "An improved method of extracting Gold and Silver from certain of their ores, and utilizing some of the other products of the process," which is more particularly described in the specification which is hereunto annexed ; and that they, the said Petitioners, have deposited with the Honorable the Treasurer of the Colony of New South Wales the sum of Twenty Pounds sterling, for defraying the expense of granting these Letters of Registration, as required by the Act of Council, sixteenth Victoria, number twenty-four ; and have humbly prayed that I would be pleased to grant Letters of Registration, whereby the exclusive enjoyment and advantage of the said invention or improvement might be secured to them for a period of fourteen years : And I, being willing to give encouragement to all inventions and improvements in the arts or manufactures which may be for the public good, and having received a report favourable to the prayer of the said Petition, from competent persons appointed by me to examine and consider the matters stated therein and to report thereon for my information, am pleased, with the advice of the Executive Council, and in exercise of the power and authority given to me by the said Act of Council, to grant, and do by these Letters of Registration grant unto the said Stephen Osborne and Andrew Thomas, their executors, administrators, and assigns, the exclusive enjoyment and advantage of the said invention or improvement, for and during the term of fourteen years from the date hereof ; to have, hold, and exercise unto the said Stephen Osborne and Andrew Thomas, their executors, administrators, and assigns, the exclusive enjoyment and advantage thereof, for and during and unto the full end and term of fourteen years from the date of these presents next and immediately ensuing, and fully to be complete and ended : Provided always, that if the said Stephen Osborne and Andrew Thomas shall not, within three days after the granting of these Letters of Registration, register the same in the proper office in the Supreme Court, at Sydney, in the said Colony of New South Wales, then these Letters of Registration, and all advantages whatsoever hereby granted, shall cease and become void.

In witness whereof, I have hereunto set my sign manual, and have caused the present Letters of Registration to be sealed with the seal of the said Colony of New South Wales, at Government House, Sydney, in New South Wales, this twelfth day of January, in the year of our Lord one thousand eight hundred and eighty-four.

[L.S.]

AUGUSTUS LOFTUS.

Improved method of extracting Gold and Silver from certain of their ores, &c.

SPECIFICATION of STEPHEN OSBORNE, of Buxton-street, North Adelaide, in the province of South Australia, mining engineer, and ANDREW THOMAS, of Gresham-street, Adelaide, in the same province, analytical chemist, of an invention for "An improved method of extracting Gold and Silver from certain of their ores, and utilizing some of the other products of the process."

THESE improvements relate to the method of extracting gold and silver from their ores by the calcination of the raw pyrites or tailings from quartz-crushing mills or stamps when these contain, in addition, copper and such other of the baser metals as are capable of forming soluble salts on being submitted to the first calcining stage of this process.

It is of great importance to the success of the process that the ore or other substance to be operated upon should be as free as possible from earthy and silicious matter, and that it should be in a state of fine powder before the first calcination is commenced.

Our method of procedure is as follows:—The previously prepared ore is calcined at a low dull red heat in a calcining furnace. This may be constructed either on the reverberatory or revolving cylinder principle; but in the use of the former frequent stirring is necessary, and care must be taken that the heat is kept as regular as possible. It is sometimes of advantage also to make use of jets of superheated steam during the process of calcination, though we do not claim this as part of our invention. The calcining is to be continued until the scintillations or sparks arising from the combustion of the sulphur have ceased, and the sulphides of the various baser metals have been converted into the soluble salts of their respective bases. Careful testing with the usual reagents will show when this has been accomplished, and the requisite point reached for drawing the charge. When this has been done it is lixiviated in tanks with false bottoms, or any other apparatus which will effect the same purpose. This may be accomplished either whilst the charge is hot, or by means of water separately heated, or by such other suitable menstruum as may be required, according to the nature of the ore which is being operated upon.

When thoroughly washed, which may be known by applying the usual tests for copper or other baser metals whose presence is suspected, the calcined ore is dried and mixed with from 5 to 15 per centum of common salt, or the salt may be added in strong solution before the drying takes place. The mixture of ore and salt is then calcined in such furnace, and with such precautions as before mentioned.

This process should be conducted at a dull red heat, which may be slightly increased towards the end, and should be continued for from two to four hours, according to the nature of the ores and the state of the furnace.

The charge is then drawn, allowed to cool, and transferred to the amalgamator. Here it is ground for a short time to remove any lumps which may have formed during calcination, and, being mixed with the proper quantity of mercury, is amalgamated in the usual way.

Our method of utilizing the products resulting from the above process is as follows:—If the liquor from the lixiviating tanks is found on testing to contain silver, that metal is precipitated as chloride, removed and treated in the usual way, or otherwise, by Claudet's process. The clear liquor is then tested for copper or other metals. These, if found in payable quantities, are also precipitated by any of the processes now in use.

Having thus fully described our process, we claim as new: The process, substantially as herein described, for removing the baser and more deleterious metals before the final amalgamation takes place, by the adoption of two stages in the process of calcination, combined with the use of common salt at the particular stage of the process, as before described.

In witness whereof we have hereunto set our hands and seals, this twenty-ninth day of September, A.D. 1883.

Witness to both signatures—

A. V. TURNER, a Justice of the Peace for the Province of New South Wales.

S. OSBORNE, M.E.
A. THOMAS, F.C.S.

This is the specification referred to in the annexed Letters of Registration granted to Stephen Osborne and Andrew Thomas, the twelfth day of January, A.D. 1884.

AUGUSTUS LOFTUS.

REPORT.

Sir,

The petition of Messrs. Stephen Osborne and Andrew Thomas, for Letters of Registration for an invention entitled "An improved method of extracting Gold and Silver from certain of their ores, and utilizing some of the other products of the process," having been referred to us, we have examined the specification accompanying the same, and have the honor to report that we see no objection to the issue of Letters of Registration as prayed for.

Sydney, 13 October, 1883.

We have, &c.,

J. SMITH.
A. LEIBIUS.

The Under Secretary of Justice.

No. 1360.

[Assignment of No. 1217. See page 121 of Return of 1883.]



A.D. 1884, 16th January. No. 1361.

A PROCESS OF, AND APPARATUS FOR, EXTRACTING METALS FROM THEIR ORES.

LETTERS OF REGISTRATION to Albert Daniel Ancel and Jean Marie Antonin Thiollier, for a Process of, and Apparatus for, Extracting Metals from their ores.

[Registered on the 17th day of January, 1884, in pursuance of the Act 16 Vic. No. 24.]

BY HIS EXCELLENCY THE RIGHT HONORABLE SIR AUGUSTUS WILLIAM FREDERICK SPENCER LOFTUS (commonly called LORD AUGUSTUS LOFTUS), Knight Grand Cross of the Most Honorable Order of the Bath, a Member of Her Majesty's Most Honorable Privy Council, Governor and Commander-in-Chief of the Colony of New South Wales and its Dependencies.

TO ALL TO WHOM THESE PRESENTS SHALL COME, greeting :

WHEREAS ALBERT DANIEL ANCEL and JEAN MARIE ANTONIN THIOILLIER, both of Paris, in the Republic of France, have by their Petition humbly represented to me that they are the authors or designers of a certain invention or improvement in manufactures, that is to say, of an invention entitled "A Process of and Apparatus for Extracting Metals from their Ores," which is more particularly described in the specification and sheet of drawings which are hereunto annexed ; and that they, the said Petitioners, have deposited with the Honorable The Treasurer of the said Colony of New South Wales the sum of Twenty Pounds sterling, for defraying the expense of granting these Letters of Registration, as required by the Act of Council, sixteenth Victoria number twenty-four ; and have humbly prayed that I would be pleased to grant Letters of Registration, whereby the exclusive enjoyment and advantage of the said invention or improvement might be secured to them for a period of fourteen years : And I, being willing to give encouragement to all inventions and improvements in the arts or manufactures which may be for the public good, and having received a report favourable to the prayer of the said Petition from competent persons appointed by me to examine and consider the matters stated therein and to report thereon for my information, am pleased, with the advice of the Executive Council, and in exercise of the power and authority given to me by the said Act of Council, to grant, and do by these Letters of Registration grant unto the said Albert Daniel Ancel and Jean Marie Antonin Thiollier, their executors, administrators, and assigns, the exclusive enjoyment and advantage of the said invention or improvement, for and during the term of fourteen years from the date hereof ; to have, hold, and exercise unto the said Albert Daniel Ancel and Jean Marie Antonin Thiollier, their executors, administrators, and assigns, the exclusive enjoyment and advantage thereof, for and during and unto the full end and term of fourteen years from the date of these presents next and immediately ensuing, and fully to be complete and ended : Provided always, that if the said Albert Daniel Ancel and Jean Marie Antonin Thiollier shall not, within three days after the granting of these Letters of Registration, register the same in the proper office in the Supreme Court, at Sydney, in the said Colony of New South Wales, then these Letters of Registration, and all advantages whatsoever hereby granted, shall cease and become void.

In witness whereof, I have hereunto set my sign manual, and have caused the present Letters of Registration to be sealed with the seal of the said Colony of New South Wales, at Government House, Sydney, in New South Wales, this sixteenth day of January, in the year of our Lord, one thousand eight hundred and eighty-four.

AUGUSTUS LOFTUS.

A Process of, and Apparatus for, Extracting Metals from their ores.

SPECIFICATION of the Invention of ALBERT DANIEL ANCEL and JEAN MARIE ANTONIN THOLLIER, both of Paris, in the Republic of France, for "A Process of, and Apparatus for, Extracting Metals from their Ores."

OUR invention relates to the extraction of metals from ores by the employment of electricity, and it consists essentially in causing the ore or metalliferous substance itself to act as a soluble electrode immersed in a liquid capable of acting upon the metal, as hereinafter described. This liquid is so constituted, that under the influence of an electric current, the bodies transferred to the pole formed by the ore dissolve the metallic matter contained in the latter.

When the ore is employed as a positive electrode, the metals or metallic compounds therein contained are dissolved, and, under the decomposing influence of electricity, the metals are transferred to the negative pole, where they are deposited in a pure metallic state, as hereinafter explained.

When the ore is employed as a negative electrode, the metals or metallic compounds are dissolved, and the metals are transferred to the positive pole in the condition of oxide or acid, and are subsequently reduced to the metallic state, as hereinafter explained.

The electricity necessary for the application of the improved process may be obtained from any convenient source, such as a galvanic or other battery, or from a magneto or dynamo electric machine.

The intensity of the current is regulated according to the nature of the ores, and the resistance opposed by the bath to the decomposition resulting from the elements of which it is composed.

The liquid in which the ore is immersed, consists of a solution of an acid, a base, or a salt, and the nature of the materials of which it is composed varies according to the composition of the ores to be treated, as hereinafter explained. The baths best adapted for several ores, capable of being treated with great advantage according to this process, are hereinafter described, in order to illustrate the application of the invention.

The improved apparatus is equally well adapted for treating metallic substances generally, as well as ores, matts, complex metals, and the like, from which it is necessary to extract the valuable portions or elements by means of electricity.

And in order that our said invention may be fully understood, we shall now proceed more particularly to describe the same, and for that purpose shall refer to the several figures on the annexed sheet of drawings, the same letters of reference indicating corresponding parts in all the corresponding figures.

Fig. 1 of the accompanying drawing is a longitudinal section, fig. 2 is a plan, and fig. 3 is a transverse section of an apparatus constructed according to this invention.

The chemical bath or solution is contained in a tank or vessel *b*, of wood, but which may be made of metal if preferred, provided that it is properly insulated from the ground, and is not liable to be attacked by the liquid, or is suitably protected from the decomposing action of the latter by varnishing, coating, or lining. Wood is to be preferred to metal, which is expensive, and always involves waste of electricity.

When wooden tanks are employed, they are lined internally with lead, or, as is preferable for the above reasons, with india-rubber or caoutchouc, to prevent leakage; but when the liquid is an inexpensive one, such as some of the liquids hereinafter described, the tanks may be placed on a waterproof floor, covered with pitch or sheet lead, and any leakage may thus be collected in a suitable receptacle.

The ore is contained in boxes *a*, constructed of perforated wood, wickerwork, porous earthenware, or other pervious material, and are preferably rectangular, narrow, and of small dimensions, relatively to the tank. Wood is the best material to employ in their construction, but good results may be obtained in some cases by the use of receptacles made of wicker-work or porous earthenware, and caoutchouc, gutta-percha, or ebonite may sometimes be employed. The receptacles may also be constructed of metal, such as sheet-iron, enamelled or coated with resin, pitch, caoutchouc, or other coating, proof against the action of the liquids. These receptacles are preferably in the form of an elongated rectangle in cross section, as shown in the drawing.

When the receptacles are constructed of non-porous materials, the two large sides are perforated, and the perforations are made as small and as near together as possible, so as to allow of an unimpeded circulation of the liquid, and at the same time support or retain the ore.

In some cases, when the ore requires to be very finely ground, the two perforated sides of the receptacles may be lined with a woven fabric; but as this involves a certain waste of electric force, it is generally preferable to let some of the ore fall out on to the bottom of the tank, where it may be collected when required. For this purpose a sufficient space must be left between the bottoms of the receptacles containing the ore, and the bottom of the tank containing the bath. One of the large sides of each box or receptacle *a* is capable of opening to facilitate the removal of the ore, which, during the treatment, will have become somewhat agglomerated.

The two narrow vertical sides or end of the boxes are provided with handles to facilitate their manipulation. The ore, ground or otherwise, is introduced mechanically into the boxes. Porous receptacles may be employed with advantage in the case of ground or pulverized ore.

In order to effectually connect the ore with the positive or negative pole of the battery or other source of electricity, conducting electrodes *d*, proof against the action of the liquid, such as retort, carbon, coke, or plumbago, or metal for example, are introduced with the body of the ore.

The proper material to employ for this purpose varies according to the nature of the bath, as is well understood by electro chemists; but metal is seldom employed, except as a negative electrode.

Substances capable of conducting electricity and resisting the action of the chemical agents are not numerous, and are almost exclusively confined to retort, carbon, coke, and plumbago or plumbago. Pulverized plumbago, agglomerated with about 10 per cent. of greasy clay, and made into blocks or slabs of suitable dimensions, which are afterwards baked in the same manner as ordinary bricks, forms an anode sufficiently proof against the chemical action, and possessing sufficient conductivity. When the ore is a bad conductor, it should be mixed with fragments of coke, retort, carbon, or plumbago, in addition to the slabs or plates *d* which are introduced into the mass of ore. By these means the current is distributed throughout the ore, and the separation of the metallic matter is facilitated. The fragments referred to, being larger than the particles of pulverized ore, may be subsequently separated by sifting with water, and used again.

Under

A Process of, and Apparatus for, Extracting Metals from their ores.

Under these conditions the plumbago electrodes and the ore form practically a solid mass, in which, under the influence of a current of sufficient intensity, all the parts (such as the metals and the combinations of metals with metalloids) that are not proof against the action of the chemical agents are dissolved and eliminated.

The electrodes *d*, thus introduced into the ore, communicate with a metal frame composed of bars *e*, preferably of copper, which is joined to one of the poles of the machine or other electrical generator.

The metals or metallic substances extracted from the ores are deposited on plates *f*, suspended in close proximity to the porous or perforated sides of the receptacles *a* containing the ore. When the ore acts as a positive electrode, the plates *f* are of metal, preferably of copper. The metals extracted from the ore are deposited on these plates in a pure metallic state, sometimes solid, sometimes pulverulent, and these plates *f* are suspended from a copper frame *g*, which in turn communicates with the negative pole of the generator.

When the ore acts as a negative electrode, the plates *f* are preferably composed of plumbago, and are connected by a copper frame with the positive pole of the generator.

The boxes or receptacles *a* filled with ore are placed in the tank *b* containing the solution forming the electric bath, and arranged as illustrated in figs. 1, 2, and 3 of the drawings.

These receptacles are supported at a certain distance from the bottom upon wooden chocks or ledges *c*, and the bars *e* connected to the electrodes *d* are supported by the sides of the tank *b*.

These connections are established by means of clamps, binding screws, or simple contact; but it is important that the contact should be as perfect as possible, and with this object all the metallic parts of the frames and electrodes that are in contact are carefully scoured. Under these conditions the vessel *b* is filled with a suitable chemical liquid, as hereinafter explained, and the electric current is caused to pass. The agents which pass to the pole formed by the ore dissolve some or all of metallic parts. When the ore constitutes the positive pole, the substances are deposited on the plates of the negative pole, in the condition of pure metal. When the ore acts as the negative pole, the substances are deposited on the plates of the positive pole, in the condition of metallic peroxide; but this occurs with but few ores.

Small receptacles, composed of lead or wood, should be arranged underneath the receiving electrodes *f*, for the reception of the metallic particles that become detached from the latter.

The substances which fall off the electrodes *f* drop into these receptacles, and are thus preserved from mixing with the particles of ore or other matter at the bottom of the tank. In some cases, it will be advantageous to raise the temperature of the bath to a point approaching ebullition, in order to facilitate and accelerate the decomposition of the ore by the chemical agents, and the deposit of the metallic matter. For this purpose, steam is caused to circulate in a lead or copper worm, arranged at the bottom of the tank. The temperature must not however be raised quite to boiling point, as this would set up an agitation of the liquid that would prejudice the success of the operation.

After the action of the current has proceeded for a certain time, and it has been ascertained by testing a sample or otherwise, that the ore no longer contains any of the metal or metals which are to be extracted by means of the operation, the boxes or receptacles *a*, which now contain only the gangues or matrix are removed and emptied. This may be accomplished by passing bars of wood or iron through handles *i*, provided on the end of the said receptacles, and then placing two other bars at right angles to and underneath the former, thus enabling the whole of the receptacles to be hoisted out of the vessel by means of pulleys. If the liquid of the bath is of small value, the receptacles may be opened and the worthless gangues thrown away; but when it is desired to preserve the liquid, or when the ore still contains valuable matter which is capable of being subsequently extracted by putting it into a chemical bath of a different composition to the first, this matter is submitted to lixiviation in the ordinary manner.

The electrodes *f*, upon which the metals or metallic matter has been deposited, are removed from the bath from time to time, and separated from the matter adhering to their surfaces.

The liquid composing the bath is drawn off occasionally, and allowed to settle in a separate tank, and after removing the accumulation of ore-dust from the bottom of the vessel *b*, the latter is refilled with clear liquid by means of pumps.

The following proportions and dimensions are found to give good results in practice. The internal dimensions of the tank *b* are about 3 yards in length by about 2 feet 6 inches wide and 3 feet deep. The dimensions of the boxes *a* are 1 foot 2 inches long by 4 inches wide and 2 feet deep internally. Forty such boxes, each containing about a hundredweight of ore, may be treated in one bath, being at the rate of about 2 tons per bath. A dynamo machine requiring about 15-horse power will supply electricity enough for about fifty baths, thus enabling 100 tons of ore to be operated upon simultaneously. The dimensions of the apparatus and strength of current may evidently vary, however, between wide limits, according to circumstances; and the time occupied by the operation also varies, according to the nature of the ore, from a few hours to several days. Ores containing metals, combined with metalloids, such as sulphur, arsenic, tellurium, and the like, require more time than other ores, as a part of the electric force is expended in producing the oxygen necessary for the conversion of these materials into soluble salts. An excess of hydrogen is also evolved at the negative pole, which impedes the regular deposit of metal. It is consequently advisable to roast the ore, when possible, with great care, in order to drive off the greater part of the metalloids.

The acids pass to the positive pole, and, in presence of the nascent oxygen which is formed at this pole, act with great rapidity on the metallic portion of the ore, when the latter is arranged as a soluble positive electrode. The metallic oxides are subsequently attracted by the negative electrodes, and are reduced by the nascent hydrogen formed thereon, and are deposited upon these electrodes in a pure metallic state. This mode of operating constitutes one of the features of our invention.

When the ore constitutes the negative electrode, the metallic matter is quickly acted on by the bases which pass to this pole, when the salt employed in the bath is a salt of potassa, soda, or ammonia. It will be advantageous to conduct the operation in this manner in certain cases, such for example as when the ore contains substances such as sulphides, tellurides, arsenides, and the like, that are not readily acted upon by acids, even when employed under the influence of electricity.

In order that the operation may be successfully conducted, it is necessary that the metal to be dissolved should be capable of readily forming a soluble combination with the base employed. For example,

A Process of, and Apparatus for, Extracting Metals from their ores.

example, gold, lead, and antimonium are suitable metals to be dissolved when the base of the salt is soda or potash; or copper, silver, nickel, and cobalt, when the ammonia is the base employed. The bath may also be composed of solutions of soluble bases, such as potash, soda, and ammonia.

In certain cases it is advantageous to employ ammonia; but its volatile nature and the odour which it emits are serious objections to its use, and render it necessary to close the vessels containing the solution, and to draw off the liquid into other closed vessels when the electrodes require to be removed, the vapours being drawn off by means of pumps, and condensed in the usual manner.

These objections to the employment of ammonia render it generally preferable to employ carbonate of ammonia, the effect obtained being similar, but less advantageous in certain respects.

It is often advantageous, as hereinafter explained, to employ bases in preference to salts and acids, because bases form with the metals somewhat unstable salts that are very readily decomposed by electricity. The result is, that with the same electric force a much greater effect is obtained.

In applying this invention to the treatment of ore containing silver alone in the native state, it is preferable to employ a bath composed of ammonia, or carbonate of ammonia, or a sulphate or nitrate of soda, or a soluble cyanide. Sea salt may also be employed, but in this case it is advisable to heat the solution. Soluble cyanide may be employed, but it is too expensive in practice.

When the ore contains gold or platinum alone, the bath may be composed of sulphates, nitrates, soluble cyanides, and the like. Chloride of sodium is to be preferred in practice as a salt; but the best results are obtained by a bath formed of a solution of soda or potash. Ores containing platinum only may be treated in baths similar to those described for the treatment of gold, but a solution of sea salt is preferable.

When the ore contains two or three of these metals (gold, silver, or platinum) it is preferably treated in a solution of sea salt.

The metals are extracted simultaneously, and separated by known processes. Processes based on the employment of electricity may also be employed for this purpose.

Ammonia, and, next to ammonia, carbonate of ammonia, forms the best bath for ore containing chloride and sulphide of silver. Good results may also be obtained by employing a concentrated solution of chloride of sodium at an elevated temperature. Ore containing sulphide of silver is preferably treated in a bath of ammonia.

In the case of ore containing telluride of gold, sea salt or cyanide of potassium may be employed, the telluride being placed at the positive pole. The action is somewhat slow, but the gold is obtained in the metallic state. The ore may constitute the negative pole, in which case the soda which passes to the negative pole acts speedily on the telluride, and the gold is carried to the positive pole in the condition of auric acid, from which pure gold may be obtained by melting with carbon and borax.

When gold and silver exist in the ore, simultaneously with lead, copper, or iron, and these metals are combined with metalloids, such as sulphur, chloride, arsenic, tellurium, and the like, or with oxygen, a heated solution of chloride of sodium is employed. With a moderate current, the gold, silver, copper, and lead are collected at the negative pole, and the iron falls to the bottom of the vessel in the condition of oxide.

This process is accelerated by previously roasting the ore. The materials may be first treated in other baths, such as a bath of potash for the extraction of the gold and lead, which are then separated by cupellation, subsequently treating the said materials in an ammoniacal bath to extract the silver and copper.

This improved process is most advantageously applied in the treatment of ores containing metals combined with metalloids, as it enables the whole of the valuable metal to be readily and cheaply extracted without any waste whatever. Ores of gold, silver, and platinum usually contain a comparatively small quantity of metal, and consequently require to be mixed with conducting materials.

The precious metals being less readily dissolved by the action of the bath, require a considerable amount of electric power, especially when the metals are present in the native state; but when combined with metalloids and water, power can be conveniently obtained. The advantages of the improved system of extraction, hereinbefore described, are very important, as the cost of the mercury usually employed with its attendant objections are entirely obviated, and the metals are completely extracted directly in the metallic state, absolutely without any waste whatever. When the improved process is compared with the known processes operating by fusion, it will be observed that a considerable saving of labour, plant, and materials is also effected.

Zinc has heretofore been laboriously prepared in expensive retorts, with the consumption of a large quantity of coal, and great loss from waste by volatilization, and in the form of residue. To extract zinc from calamine or carbonates, the carbonate must be previously reduced by calcination to the condition of oxide. Blende is a sulphide of zinc, usually mixed with sulphides of iron and lead, and should be roasted carefully to bring it to the same condition as the calamine, except when lime is present.

The ore is employed as a soluble positive pole in a bath composed of alkaline, saline, or preferably of basic materials, such as ammonia or carbonate of ammonia.

The zinc obtained by this process is extremely flexible and ductile. This process also enables iron to be galvanized with zinc direct from the ore.

To extract aluminium from clay, bauxite, and other aluminiferous substances, the bath is preferably composed of a concentrated solution of chloride of aluminium, or double chloride of sodium and aluminium, or double chloride of aluminium and ammonium, with a powerful current of electricity.

The bath may also consist of a concentrated solution of soda or potash, or a saturated bath of aluminate of soda. The intensity of the current must be considerable, otherwise the alumina will remain at the positive pole without being decomposed.

In applying this invention to the manufacture of magnesium, artificial carbonate of magnesia is preferably employed as the raw material, being obtained by precipitating natural salts of magnesia by means of carbonate of soda. When this material is employed it is placed in porous receptacles in the bath, and being dissolved without leaving any residue, the operation of removing the receptacles for the purpose of throwing away the gauge may be dispensed with. A concentrated solution of chloride of magnesium is preferably employed as a bath or double chloride of magnesium and sodium, or double chloride of magnesium and ammonium.

To

A Process of, and Apparatus for, Extracting Metals from their ores.

To extract lead from its ore, a bath of marine salt, or preferably a solution of chloride of lead, raised to nearly boiling point, is employed.

The lead thus obtained is of great purity, but may sometimes be slightly alloyed with zinc, which admits of being readily separated by known means. The residue contains silver and copper, which can be extracted by means of a bath of ammonia or a saline bath.

This invention may be very advantageously applied to the separation of silver from lead. The argentiferous lead is melted with a small quantity of zinc, and the alloy of lead, silver, and zinc, which is formed at the surface during the cooling is placed in the receptacles of the electrical apparatus hereinbefore described. A bath of sulphate of zinc, or preferably carbonate of ammonia, is employed. The zinc alone is dissolved, and is deposited in a pure condition on the negative electrode. The lead and silver are separated by cupellation. The cost of distillation and the waste of zinc and silver which it involves are thus avoided.

Ores containing antimony are treated in a heated solution of potash or a saline bath, containing acids capable of forming soluble salts with antimony.

Mercury is obtained by treating the cinnabar in an alkaline bath, or preferably in a bath of sulphate, nitrate, or bichloride of mercury.

The waste by volatilization and the noxious fumes resulting from the ordinary treatment are entirely obviated.

Cupreous ores, such as oxides and carbonates, are preferably treated in an ammoniacal or saline bath. Grey copper ores, containing arsenic or antimony, are well adapted for treatment according to this invention, and are roasted at a low temperature without driving off the antimony, and treated in a bath of potash, as hereinbefore described with reference to antimony, thus obtaining this metal in a state of great purity. The residue from the operation is treated in a bath of ammonia or carbonate of ammonia, for the purpose of extracting the copper and silver, which are subsequently separated by known means.

Nickel is extracted from double hydrated silicates of nickel and magnesia, by first calcining the ore with carbon, so as to reduce the nickel to the metallic state, and then treating it in a saline or preferably an ammoniacal bath. Ores containing nickel, alloyed with cobalt and sometimes with copper, are roasted to drive off the greater part of the sulphur and arsenic present in combination with the cobalt and copper, and treated in a bath of potash, or preferably soda. The cobalt alone is deposited on the negative electrodes in the condition of soluble cobaltate. The residue is treated in a bath of ammonia or carbonate of ammonia to extract the nickel and copper, which may be subsequently separated by means of a bath of sulphate of copper and a weak current, which will extract the copper, leaving the nickel, which may be fused or be purified by means of electricity in another ammoniacal bath.

Ores, such as are found in New Caledonia and in certain parts of the Pyrenees, are mixed with carbon, and melted in a furnace to remove the greater part of the manganese which these ores contain. The alloy of cobalt, nickel, and manganese thus obtained, is firstly treated by an electric current in a sodaic bath, to extract the cobalt, and subsequently in an ammoniacal bath to obtain the nickel.

In certain localities, where extensive deposits of carbonate of lime and iron are found in proximity to large falls of water available as motive power, iron may be obtained in a state of chemical purity by the employment of electrical action in combination with a chemical solution, as hereinbefore described, such as a bath of chloride of sodium or of iron for example.

Claims—

- First—The hereinbefore described process of treating metalliferous ore by electricity, for the purpose of extracting the metals therefrom, using the ore itself as a soluble electrode, and immersing it in a reducing electric bath, under the conditions described.
- Second—In the hereinbefore described treatment of metalliferous ores, the employment of electrodes, such as electrodes composed of agglomerated plumbago, or other analogous materials, proof against the action of the chemical agents.
- Third—In the hereinbefore described treatment of metalliferous ores, the employment of basic electric baths, in the manner and for the purpose indicated.
- Fourth—In the hereinbefore described process, the employment of the apparatus enabling the whole mass of ore to constitute a positive soluble or negative electrode, without the necessity for the intervention of mechanical agitation, substantially as hereinbefore described and illustrated in the accompanying drawings.
- Fifth—Each separately and distinctly the several various modifications of the hereinbefore described process, to render it applicable for the treatment of various or particular metalliferous ores, all substantially as hereinbefore described.

In witness whereof, we, the said Albert Daniel Ancel and Jean Marie Antonin Thiollier, have hereunto set our hands and seals, this twenty-eighth day of June, one thousand eight hundred and eighty-three.

ALBERT DANIEL ANCEL.
JEAN MARIE ANTONIN THIOILLIER.

Signed and sealed by the said Albert Daniel Ancel
and Jean Marie Antonin Thiollier, in the presence of,—
HENRY WILLOUGHBY, British Vice-Consul at Paris.
JOSEPH DELAGE,
ALFRED COINY,
Both of Paris, 45, rue St. Sebastien.

This is the specification referred to in the annexed Letters of Registration granted to Albert Daniel Ancel and Jean Marie Antonin Thiollier, this sixteenth day of January, A.D. 1884.

AUGUSTUS LOFTUS.

A Process of, and Apparatus for, Extracting Metals from their ores.

REPORT.

Sir,

Sydney, 22 November, 1883.
The petition of Messrs. Albert D. Ancel and Jean M. A. Thiollier, for Letters of Registration for an invention entitled "A Process of, and Apparatus for, Extracting Metals from their Ores," having been referred to us, we have examined the specification and drawings accompanying the same, and have the honor to report that we see no objection to the issue of Letters of Registration as prayed for.

We have, &c.,

J. SMITH.

A. LEIBIUS.

The Under Secretary of Justice.

[Drawings—one sheet.]

Fig. 1.

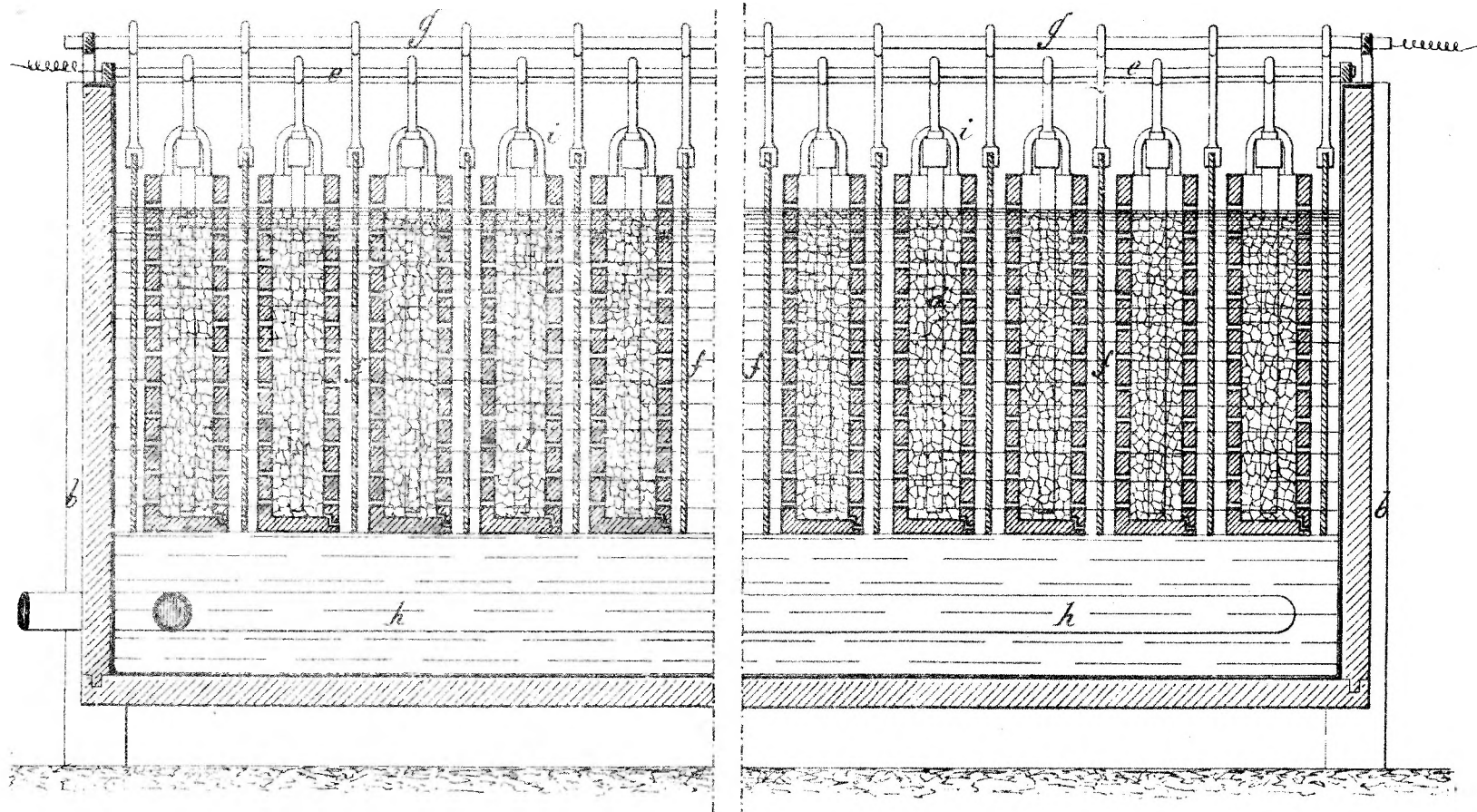


Fig. 3.

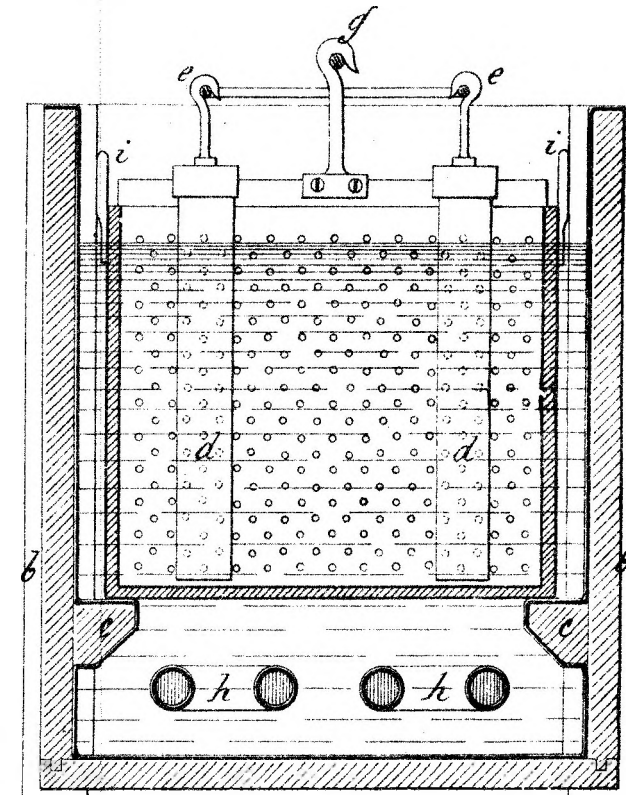
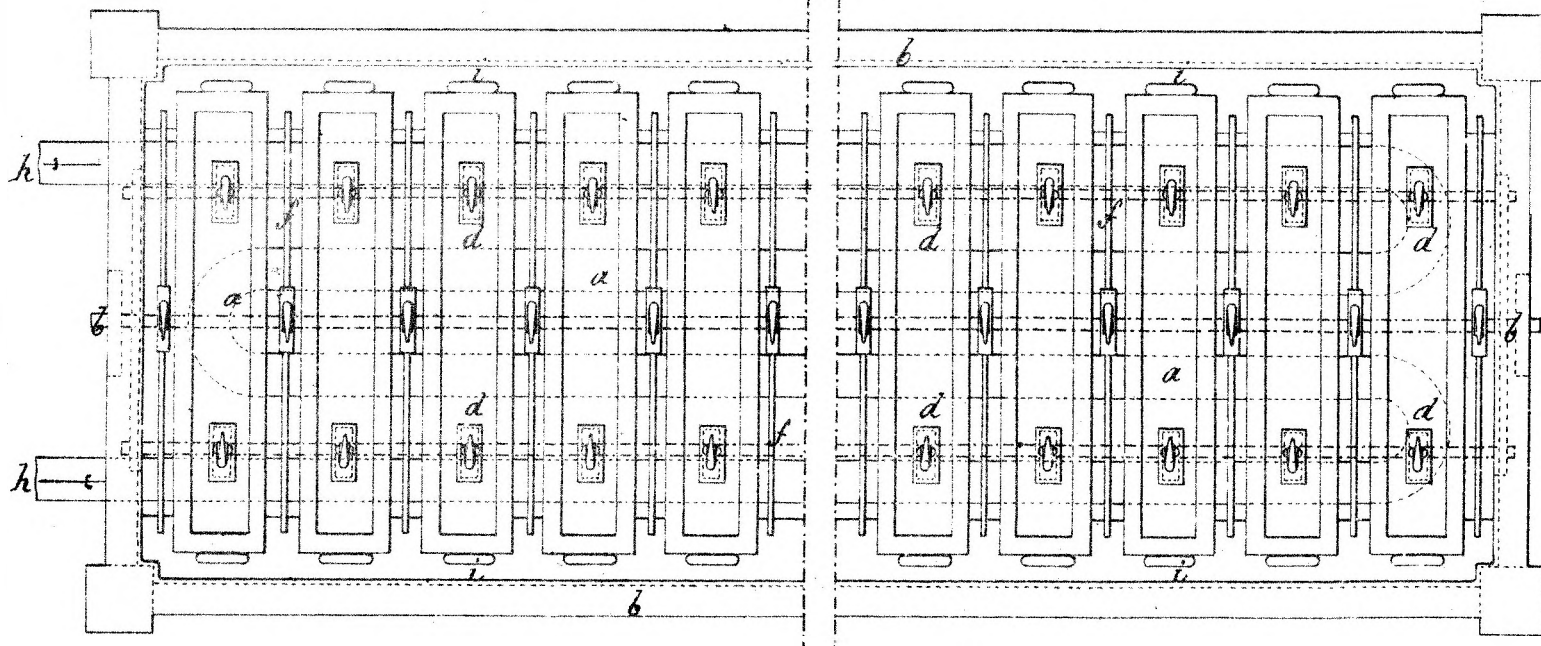


Fig. 2.



Signed at Paris
in the presence of
Joseph Delage
Alfred Coind
both of Paris
45 rue St Sebastien.

Albert Daniel Ancel.
Jean Marie Antonin Thiolliez

These are the drawings annexed to the
specification referred to in the
declaration of Albert Daniel Ancel
and Jean Marie Antonin Thiolliez.

Signed and sealed before me this 28th day
of June 1883.

Henry Wilboughby
Notaire No. 100
at Paris.

This is the Sheet of Drawings referred to in the annexed
Letters of Registration granted to Albert Daniel Ancel and
Jean Marie Antonin Thiolliez this sixteenth day of January
A. D. 1884.

Augustus Loftus.

(Sig 245.)



A.D. 1884, 16th January. No. 1362.

IMPROVED CONTRIVANCES FOR BARBING WIRE BY HAND

LETTERS OF REGISTRATION to William Woodcock and Edward West, for Improved Contrivances for Barbings Wire by Hand.

[Registered on the 17th day of January, 1884, in pursuance of the Act 16 Vic. No. 26.]

BY HIS EXCELLENCY THE RIGHT HONORABLE SIR AUGUSTUS WILLIAM FREDERICK SPENCER LOFTUS (commonly called LORD AUGUSTUS LOFTUS), Knight Grand Cross of the Most Honorable Order of the Bath, a Member of Her Majesty's Most Honorable Privy Council, Governor and Commander-in-Chief of the Colony of New South Wales and its Dependencies.

TO ALL TO WHOM THESE PRESENTS SHALL COME, greeting :

WHEREAS WILLIAM WOODCOCK, of Oamaru, in the Colony of New Zealand, manufacturer, and EDWARD WEST, of Oamaru aforesaid, commission agent, have by their Petition humbly represented to me that the said William Woodcock is the author or designer of a certain invention or improvement in manufactures, that is to say, of an invention entitled "Improved Contrivances for Barbings Wire by Hand," which is more particularly described in the specification and the sheet of drawings which are hereunto annexed; and that the said Edward West is the assignee of one-half share of and in the said invention, so far as the Colony of New South Wales is concerned; and that they, the said Petitioners, have deposited with the Honorable the Treasurer of the said Colony of New South Wales the sum of Twenty Pounds sterling, for defraying the expense of granting these Letters of Registration, as required by the Act of Council, sixteenth Victoria, number twenty-four; and hath humbly prayed that I would be pleased to grant Letters of Registration, whereby the exclusive enjoyment and advantage of the said invention or improvement might be secured to them for a period of fourteen years: And I, being willing to give encouragement to all inventions and improvements in the arts or manufactures which may be for the public good, and having received a report favourable to the prayer of the said Petition, from competent persons appointed by me to examine and consider the matters stated therein, and to report thereon for my information, am pleased, with the advice of the Executive Council, and in exercise of the power and authority given to me by the said Act of Council, to grant, and do by these Letters of Registration grant unto the said William Woodcock and Edward West, their executors, administrators, and assigns, the exclusive enjoyment and advantage of the said invention or improvement, for and during the term of fourteen years from the date hereof; to have, hold, and exercise unto the said William Woodcock and Edward West, their executors, administrators, and assigns, the exclusive enjoyment and advantage thereof, for and during and unto the full end and term of fourteen years from the date of these presents next and immediately ensuing, and fully to be complete and ended: Provided always, that if the said William Woodcock and Edward West shall not within three days after the granting of these Letters of Registration register the same in the proper office in the Supreme Court, at Sydney, in the said Colony of New South Wales, then these Letters of Registration and all advantages whatsoever hereby granted, shall cease and become void.

In witness whereof, I have hereunto set my sign manual, and have caused the present Letters of Registration to be sealed with the seal of the said Colony of New South Wales, at Government House, Sydney, in New South Wales, this sixteenth day of January, in the year of our Lord one thousand eight hundred and eighty-four.

[L.S.]

AUGUSTUS LOFTUS.

Improved Contrivances for Barbing Wire by Hand.

SPECIFICATION of WILLIAM WOODCOCK, of Oamaru, in the Colony of New Zealand, manufacturer of barbed fencing wire, and EDWARD WEST, of Oamaru aforesaid, commission agent, for an invention entitled "Improved Contrivances for Barbing Wire by Hand."

OUR invention consists of two improved contrivances for the purpose of forming barbs on wire. We twist two pieces of pointed wire in the form of a double thread (on the wire to be barbed), so that the four projecting ends will form barbs or spikes.

Our first contrivance for this purpose consists of a pair of clamps, so designed that it will grip both the main wire and the wires that are to form the barb in such a position that the barb wires may be operated upon by our second tool or key. This clamp is made of two pieces of wood, the ends of which form handles, which are pivoted to a metal plate, similarly to a nut-cracker, and are shod with metal at the parts of contact with the respective wires when clamped.

Our second contrivance is a key for twisting the wires which form the barbs on the main wire, and consists of a flat steel plate, slotted out to receive the pin and projection on the sliding block, to allow for its adjustment, so as to adjust the teeth to suit the various sizes of wire to be used. This steel plate and the block is notched out to form teeth to receive the barb wires as held in position by the clamp.

Referring to our drawings, figures 1, 2, 3, and 4 show respectively, top, front, side, and back view of our improved contrivance for clamping the wire; figures 5, 6, and 7, back, edge, and front view respectively of our improved contrivance or key for twisting or forming the barbs on the main wire; figure 8 is a side elevation of our two contrivances in the act of forming a barb; and figures 9 and 10 show how the barbs are applied to double or treble twisted wires, although our barbs may be applied to a main wire, made up of any number of strands.

In figures 1, 2, 3, 4, and 8, A is the wire to be barbed, BB the wires to form the barbs, which are clamped in their proper position between the plates A¹ and A², on wooden levers or jaws A³, into which these plates are sunk flush with their sides. The plates A² are secured by screws A⁴ to said handles A³, which are held together by plates A¹ and A⁵ and screws A⁶. Plates A² are slightly recessed in the face of the jaws, as shown in figure 2.

In figures 5, 6, 7, and 8, A and B are the wire and barbs, as before; C is a steel plate, with slot C¹ to receive the stud C² and screw pin C³, which fasten the sliding block C⁴ in required position; C⁵ and C⁶ are respectively the teeth or notches on the steel plate C, and on the sliding block C⁴, both of which are for twisting the barbs around the main wire; C⁷ is a recessed portion of the side of sliding block; and C⁸ is the screw pin washer.

The mode of operation is as follows:—The two short wires which are to form the barb are placed in the clamp in the position indicated in figures 1, 4, and 8, and firmly clamped in such position by the handles being compressed together by the operator's left hand. Then with operator's right hand the key is placed in position on the wire to be barbed, which goes between the projection C², on sliding block C⁴ and steel plate C; the teeth or notches C⁵ and C⁶, at the side, will then catch the barb wires BB, and two full turns given to the key by the operator from him over and round the main wire fastens and forms the barb in the position shown.

Having thus described the nature of our invention, and the manner of performing same, we would have it understood that we do not claim the manufacture of barbed fencing wire, but simply the contrivances which we have devised and herein explained for twisting the short lengths of wire to form the barbs on the main line of wire, whether that main line be composed of one or any number of strands. What we claim, therefore, as our improved contrivance for barbing wire by hand is—

First—The clamps for holding the main line of wire and the two short lengths for the barbs in such a position as that a suitable key will grip and twist such short lengths of wire into barbs on the main line of wire, substantially as herein described and explained, and as illustrated in figures 1 to 4 of our drawings.

Second—The key for catching the short lengths of wire held by said clamps, and twisting them around the main line of wire, so as to form them into barbs thereon, substantially as herein described and explained, and as illustrated in figures 5, 6, 7, and 8 of our drawings.

In witness whereof, we, the said William Woodcock and Edward West, have hereto set our hands and seals, this fifteenth day of September, one thousand eight hundred and eighty-three.

WILLIAM WOODCOCK.
EDWARD WEST.

(By their Agent, W. S. BAYSTON.)

Witness—

WALKER C. HART,

Clerk to Edward Waters, Patent Agent, Melbourne.

This is the specification referred to in the annexed Letters of Registration granted to William Woodcock and Edward West, this 16th day of January, A.D. 1884.

AUGUSTUS LOFTUS.

REPORT.

Sir,

Having examined the specification and drawings accompanying the petition, we have the honor to recommend that Letters of Registration should be issued to Messrs. Woodcock and West, for the invention entitled "Improved Contrivances for Barbing Wire by Hand," as shown in the drawings and described in the specification attached to the same.

Sydney, 24 September, 1883.

We have, &c.,

JAMES BARNET.

WILLIAM C. BENNETT.

The Under Secretary of Justice.

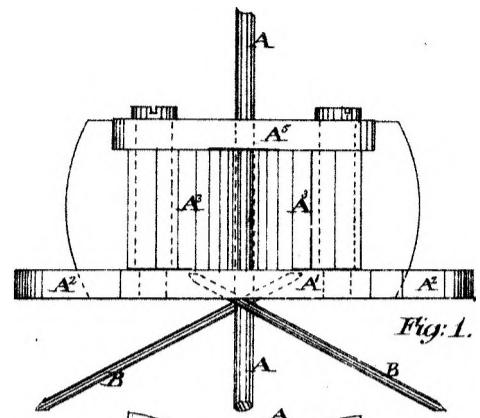


Fig. 1.

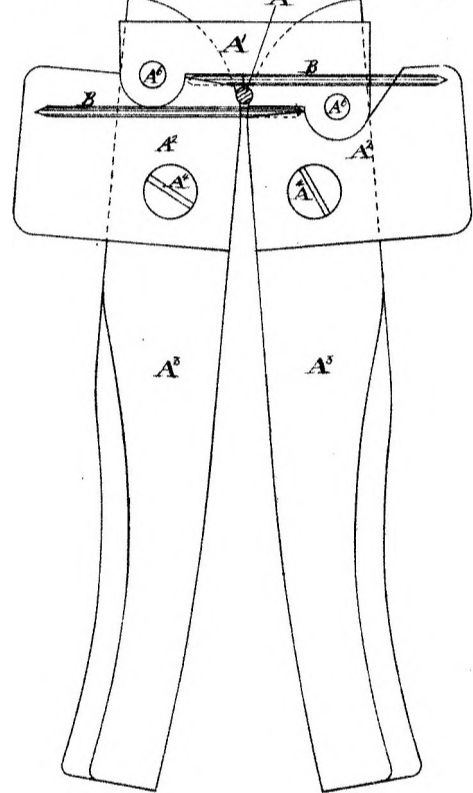


Fig. 2.

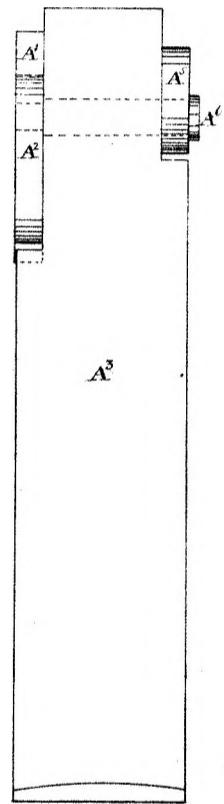


Fig. 3.

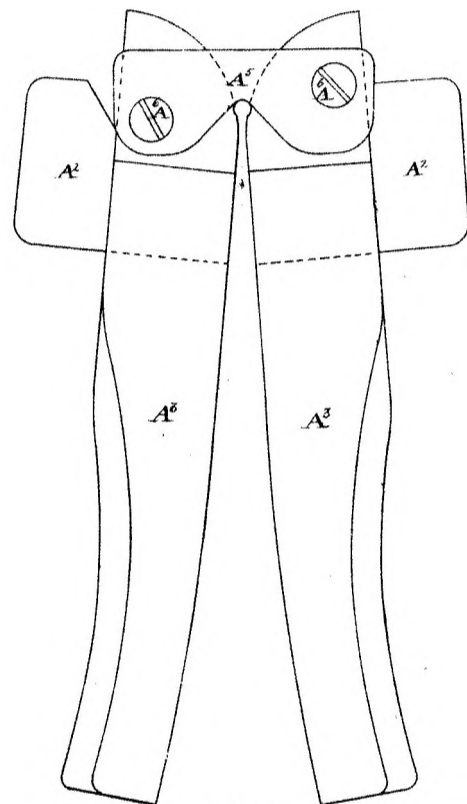


Fig. 4.

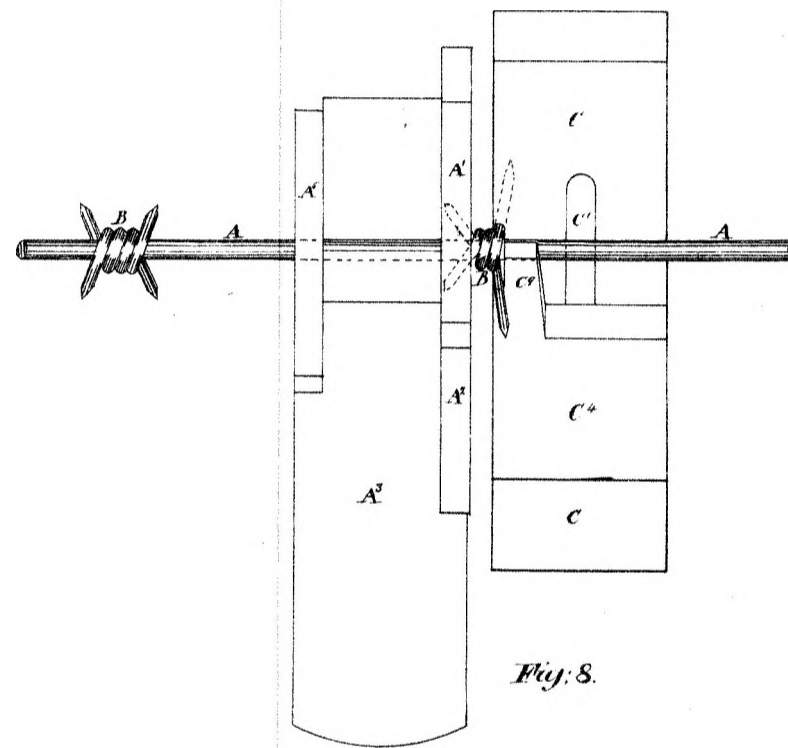


Fig. 8.

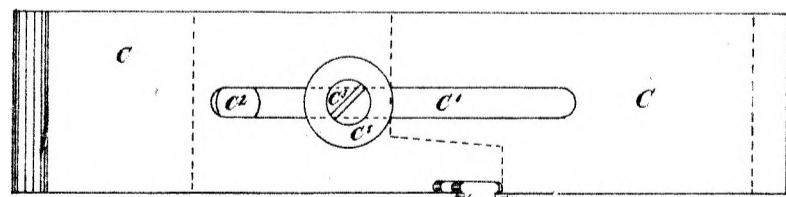


Fig. 5.

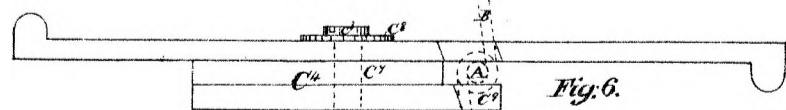


Fig. 6.

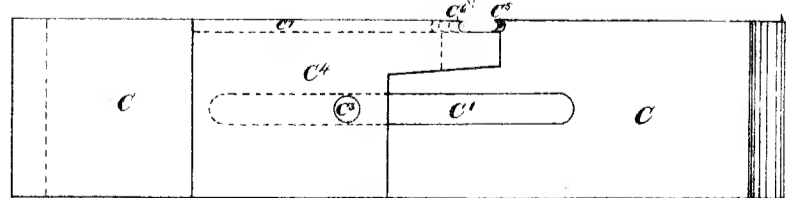


Fig. 7.

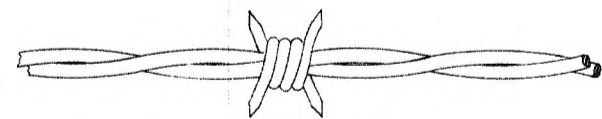


Fig. 9.

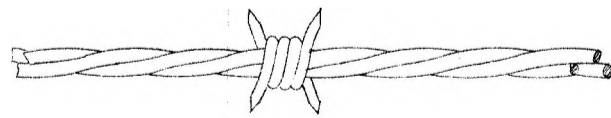


Fig. 10.

This is the Sheet of Drawings referred to in the annexed
Letters of Registration granted to William Woodcock, and
Edward West, this sixteenth day of January, A.D. 1884.

Augustus Loftus.



A.D. 1884, 16th January. No. 1363.

IMPROVEMENTS IN PIANOFORTES.

LETTERS OF REGISTRATION to Wilhelm Fischer, for Improvements in Pianofortes.

[Registered on the 17th day of January, 1884, in pursuance of the Act 16 Vic. No. 24.]

BY HIS EXCELLENCY THE RIGHT HONORABLE SIR AUGUSTUS WILLIAM FREDERICK SPENCER LOFTUS (commonly called LORD AUGUSTUS LOFTUS), Knight Grand Cross of the Most Honorable Order of the Bath, a Member of Her Majesty's Most Honorable Privy Council, Governor and Commander-in-Chief of the Colony of New South Wales and its Dependencies.

TO ALL TO WHOM THESE PRESENTS SHALL COME, greeting :

WHEREAS WILHELM FISCHER, resident in the city of Leipzig, Saxony, German Empire, hath by his Petition humbly represented to me that he is the author or designer of a certain invention or improvement in manufactures, that is to say, of an invention entitled "Improvements in Pianofortes," which is more particularly described in the specification and the sheet of drawings which are hereunto annexed; and that he, the said Petitioner, hath deposited with the Honorable the Treasurer of the said Colony of New South Wales the sum of Twenty Pounds sterling, for defraying the expense of granting these Letters of Registration, as required by the Act of Council, sixteenth Victoria, number twenty-four; and hath humbly prayed that I would be pleased to grant Letters of Registration, whereby the exclusive enjoyment and advantage of the said invention or improvement might be secured to him for a period of fourteen years: And I, being willing to give encouragement to all inventions and improvements in the arts or manufactures which may be for the public good, and having received a report favourable to the prayer of the said Petition, from competent persons appointed by me to examine and consider the matters stated therein and to report thereon for my information, am pleased, with the advice of the Executive Council, and in exercise of the power and authority given to me by the said Act of Council, to grant, and do by these Letters of Registration grant unto the said Wilhelm Fischer, his executors, administrators, and assigns, the exclusive enjoyment and advantage of the said invention or improvement, for and during the term of fourteen years from the date hereof; to have, hold, and exercise unto the said Wilhelm Fischer, his executors, administrators, and assigns, the exclusive enjoyment and advantage thereof, for and during and unto the full end and term of fourteen years from the date of these presents next and immediately ensuing, and fully to be complete and ended: Provided always, that if the said Wilhelm Fischer shall not, within three days after the granting of these Letters of Registration, register the same in the proper office in the Supreme Court, at Sydney, in the said Colony of New South Wales, then these Letters of Registration, and all advantages whatsoever hereby granted, shall cease and become void.

In witness whereof, I have hereunto set my sign manual, and have caused the present Letters of Registration to be sealed with the seal of the said Colony of New South Wales, at Government House, Sydney, in New South Wales, this sixteenth day of January, in the year of our Lord one thousand eight hundred and eighty-four.

[L.S.]

AUGUSTUS LOFTUS.

Improvements in Pianofortes.

My invention relates to pianofortes in which the notes are produced by forks of metal or other suitable material and similar to tuning forks, and the improvements consist, firstly, in the insertion between the fork and the part of the instrument to which they are attached of a hinge or a springing connection; secondly, in the attachment of the forks to a bar independent of the sounding-board, in combination with a device for transmitting to the latter the vibrations of each fork when struck by its hammer; thirdly, in means for suppressing prejudicial secondary notes accompanying the fundamental note of the forks; and fourthly, in the employment, for each or any note of the piano, of two forks, together with an arrangement of the mechanism allowing both forks or but one of them to be struck by the hammer.

On the annexed sheet of drawings, fig 1 is a transverse sectional view of a piano comprising the main parts of my invention; fig. 2 represents a modification of a part thereof; fig. 3 is a modification of another part; figs. 4 and 5 show forks provided with means for getting rid of secondary notes; while figs. 6 and 7 represent, in elevation and plan, the combination of two forks to be sounded by one hammer.

The sounding-forks hitherto used on pianos have always been rigidly fixed within the same. When a fork so arranged is struck by its hammer, the percussion thus caused is always more or less audible, in consequence whereof the musical effect of the instrument is considerably impaired.

For the purpose of remedying this deficiency, I make the connection between the forks *a* and the bar *b*, which carries the same, by means of joints or hinges *k*, as shown by figs. 1, 2, and 3, and which are preferably made of wood. The fork is screwed with its stem to the part *n* of the hinge, while the other hinge, part *s*, is fixed to the bar *b*, either directly or by the medium of an arm *i*. In order to keep the forks in their proper position, they are held with their stem or the hinge part *n* between two screws *q* and *r*, having knobs faced with soft material, such as felt or leather. Instead of these screws, however, other suitable supports may be employed. The forks may also be stayed by means of two strings, or other flexible connections fastened with one end to the movable hinge part, and with the other to a fixed part of the piano, one at least of these connections being elastic or consisting partly or entirely of a spring. This arrangement, which allows the fork to yield to a certain extent when it is struck by the hammer *e*, has proved very efficient, not only for preventing the blow of the hammer from being heard, but also for rendering the sound more sonorous.

The bar *b* carrying the forks may be attached to the sounding-board *d* or connected with the same by cross-bars. This arrangement, however, presents the disadvantage that the weight of the whole series of forks does not allow the sounding-board to vibrate with freedom, in consequence whereof the sound of the forks, when all are in their place, is not as full and strong as when but few of them are in connection with the board. For this reason I keep the bar *b* independent of the sounding-board, and I establish the connection of the forks with the latter for each fork separately at the moment it is struck by its hammer, and for the time only that its sound is desired to be heard. This connection is obtained by means of a piece which I have called the transmitter, and which is operated by the key, and adapted to convey the vibrations of the fork to the sounding-board.

According to fig. 1 the said transmitter *m* is fixed with one end to the ledge *c* of the sounding-board. In its position of rest it does not touch the fork or the hinge part *s*, but it is sufficiently elastic that, when the key *f* is depressed, the pin or lifter *g* will press its free end against the stem of the fork, or the part *s*, as the case may be, and thus produce the contact requisite for the transmission of the vibrations. This contact is maintained as long as the key is depressed, and is broken when the latter is released. If preferred the transmitter may be attached to or form one piece with the hinge part *s*, while it is arranged to be brought in and out of contact with the ledge *c*. According to the drawing the lifter *g* is operated by a lever *h* acted upon by the key *f*. The purpose of this lever is to reduce the stroke of the lifter, which would be disadvantageously great if the latter were connected to the end of the key.

In the modification represented by fig. 2 the transmitter *m* forms the head of the lifter *g*, and is so arranged that, when raised by the key, it will simultaneously touch the ledge *c* and the fork-stem or the hinge part *s*.

The bar *b* is made of a material being a bad conductor of sound. I prefer to use lead strengthened by a core of iron. In order to reduce the transmission of vibrations from the forks to the bar *b*, the arms *i* are employed, and these are, with advantage, made of two parts, between which a piece of soft material, such as felt or india-rubber, is inserted, as represented by fig. 3.

As regards the position of the forks, I have found it preferable to place the forks vertical to the sounding-board. In case the latter is horizontal the forks should therefore have a perpendicular position. The arrangement of the forks parallel or at an acute angle to the sounding-board is, however, not excluded.

For stopping the sound of the forks, dampers of the kind used in ordinary pianos or of any other suitable construction may be employed.

When forks, such as are to be used in the present case, are made to vibrate, its fundamental note is accompanied by a secondary note, which increases in strength as the pitch of the fork becomes lower, and ultimately becomes prejudicial to the effect of the instrument. This secondary note may be suppressed by means of a ring or band *v*, fig. 4, made of or lined with an elastic material and placed tightly around one of the prongs of the fork at a certain point thereof. A ring of india-rubber with a piece of felt *p* put underneath has been found particularly suitable for this purpose. The true position of the said ring must be determined by experiment, but generally it will have to be located at about one-third of the length of the prong from its point of union with the other prong.

Another medium for attaining the same purpose consists in drilling a hole *t*, fig. 5, into the fork at the point where the prongs unite with the stem, and in filling this hole with lead or other soft metal or with india-rubber.

When an instrument of superior strength of tune is required, I employ two forks for each note or for each of a part of the notes, these forks being simultaneously struck by one hammer, or, if preferred, by two hammers placed by the side of each other and operated by the touch of one key. Besides, a hammer mechanism, that may be shifted by a pedal, and of the kind sometimes used in ordinary pianofortes, may be employed, in order to allow both forks to be sounded together, or but one of them, at the will

Improvements in Pianofortes.

will of the player. Moreover, one of the forks may be tuned in the octave of the other, the fork of lower pitch being in this case the one which is struck by the hammer when but one fork is to be sounded. Fig. 6 shows an arrangement of the said kind in elevation, and fig. 7 in plan. Both forks, *a* and *a'*, are fixed to one hinge part *n*, and they are so attached thereto that the points to be struck by the hammer will be touched uniformly.

I claim as my invention—

1. In pianos in which forks are employed for producing sounds, the insertion between the forks *a* and the part of the instrument carrying the same, of a hinge *k* or a springing connection, as and for the purpose described.
2. In combination with the forks *a* provided with a hinge *k* or a springing connection, the supports *r* and *g*, substantially as hereinbefore specified.
3. The attachment of the forks *a* to a bar *b*, independent of the sounding-board, and the transmitter *m*, arranged to be lifted by the key *f*, and, in its raised position, to establish contact between the fork and the sounding-board, substantially as and for the purpose described.
4. In combination with a sounding-fork, an elastic ring or band *v* placed tightly around one of its prongs, for the purpose of suppressing the secondary note of the fork.
5. The means for suppressing the secondary note, consisting in drilling a hole *t* into the fork and filling it with a soft metal or india-rubber.
6. The combination with each or any fork *a*, of a fork *a'* arranged to be sounded simultaneously with the fork *a* by the touch of one key, together with a construction of the piano mechanism allowing the same to be so shifted by a pedal that, subsequent to the shifting, the hammer will touch the fork *a* only, substantially as hereinbefore described.

Signed and sealed, Leipsic, the 18th day of May, 1883.

Witness—

CARL RUDOLPH SCHWALBACH, Merchant,
Leipzig, Salomonstt, 23.

Inventor—

WILHELM FISCHER.

This is the specification referred to in the annexed Letters of Registration granted to Wilhelm Fischer, this 16th day of January, A.D. 1884.

AUGUSTUS LOFTUS.

REPORT.

Sir,

The petition of Mr. Wilhelm Fischer for Letters of Registration for an invention entitled "Improvements in Pianofortes," having been referred to us, we have the honor to report that we have examined the specification and drawings accompanying the same, and see no objection to the granting of the petition.

Sydney, 6 October, 1883.

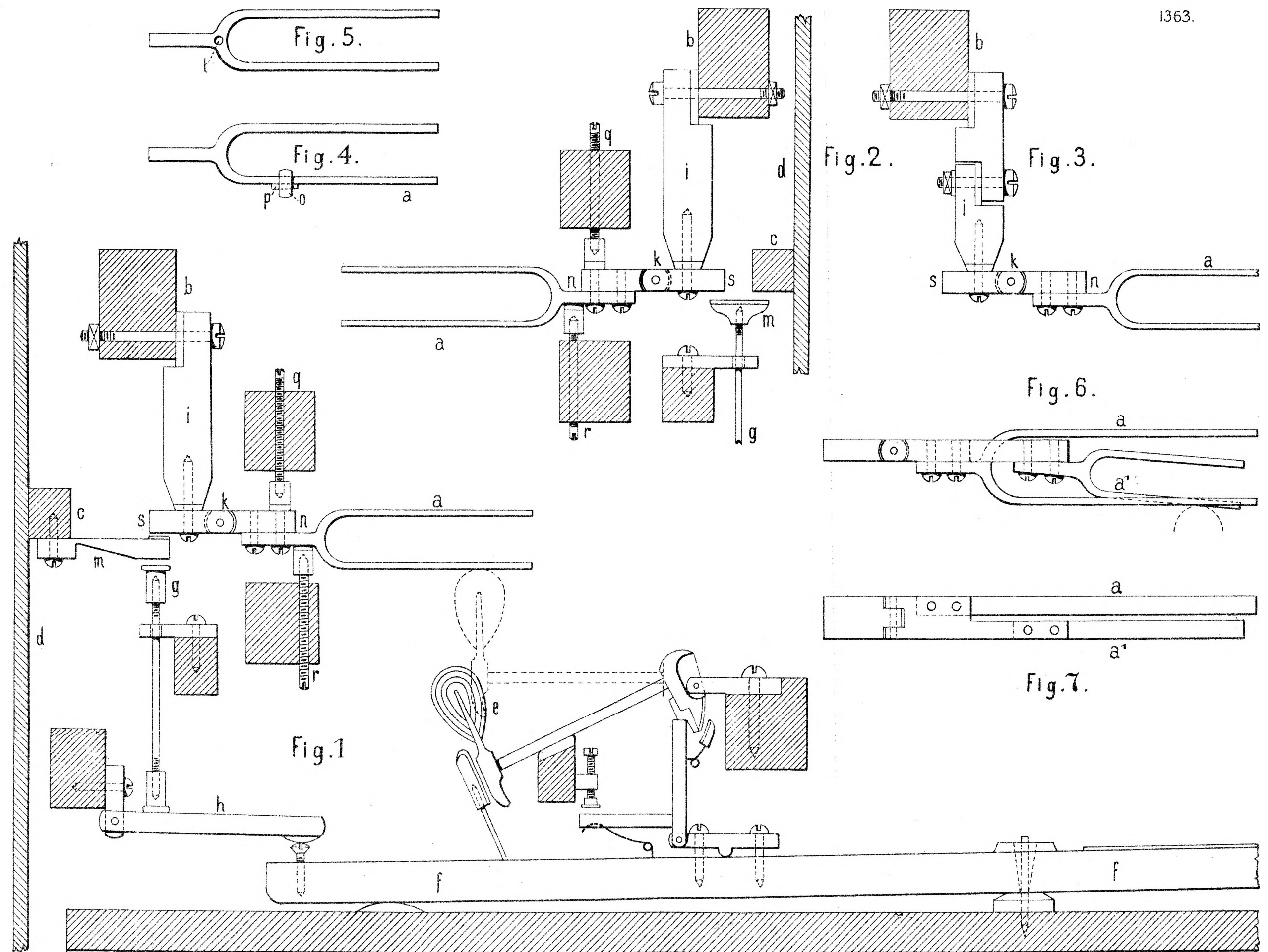
We have, &c.,

J. SMITH.

A. LEIBIUS.

The Under Secretary of Justice.

[Drawings—one sheet.]



This is the Sheet of Drawings referred to in the annexed Letters of Registration granted to Wilhelm Fischer; this sixteenth day of January, AD, 1884.

Augustus Loftus.

PHOTO-LITHOGRAPHED AT THE GOVT. PRINTING OFFICE, SYDNEY, NEW SOUTH WALES.

(Sig245-)



A.D. 1884, 16th *January*. No. 1364.

IMPROVEMENTS IN VENTILATING AND EXHAUST FANS.

LETTERS OF REGISTRATION to James Morgan Blackman, for Improvements in Ventilating and Exhaust Fans, and in the application thereof for drying Malt and other materials.

[Registered on the 17th day of January, 1884, in pursuance of the Act 16 Vic. No. 24.]

BY HIS EXCELLENCY THE RIGHT HONORABLE SIR AUGUSTUS WILLIAM FREDERICK SPENCER LOFTUS (commonly called LORD AUGUSTUS LOFTUS), Knight Grand Cross of the Most Honorable Order of the Bath, a Member of Her Majesty's Most Honorable Privy Council, Governor and Commander-in-Chief of the Colony of New South Wales and its Dependencies.

TO ALL TO WHOM THESE PRESENTS SHALL COME, greeting :

WHEREAS JAMES MORGAN BLACKMAN, of Chicago, in the county of Cook, and State of Illinois, in the United States of America, hath by his Petition humbly represented to me that he is the author or designer of a certain invention or improvement in manufactures, that is to say, of an invention entitled "Improvements in ventilating and exhaust fans, and in the application thereof for drying malt and other materials," which is more particularly described in the specification and the sheet of drawings which are hereunto annexed; and that he, the said Petitioner, hath deposited with the Honorable the Treasurer of the said Colony of New South Wales the sum of Twenty Pounds sterling, for defraying the expence of granting these Letters of Registration, as required by the Act of Council, sixteenth Victoria, number twenty-four; and hath humbly prayed that I would be pleased to grant Letters of Registration, whereby the exclusive enjoyment and advantage of the said invention or improvement might be secured to him for a period of fourteen years: And I, being willing to give encouragement to all inventions and improvements in the arts or manufactures which may be for the public good, and having received a report favourable to the prayer of the said Petition from competent persons appointed by me to examine and consider the matters stated therein and to report thereon for my information, am pleased, with the advise of the Executive Council, and in exercise of the power and authority given to me by the said Act of Council, to grant, and do by these Letters of Registration grant unto the said James Morgan Blackman, his executors, administrators, and assigns, the exclusive enjoyment and advantage of the said invention or improvement, for and during the term of fourteen years from the date hereof; to have, hold, and exercise unto the said James Morgan Blackman, his executors, administrators, and assigns, the exclusive enjoyment and advantage thereof, for and during and unto the full end and term of fourteen years from the date of these presents next and immediately ensuing, and fully to be complete and ended: Provided always, that if the said James Morgan Blackman shall not, within three days after the granting of these Letters of Registration, register the same in the proper office in the Supreme Court, at Sydney, in the said Colony of New South Wales, then these Letters of Registration, and all advantages whatsoever hereby granted, shall cease and become void.

In witness whereof, I have hereunto set my sign manual, and have caused the present Letters of Registration to be sealed with the seal of the said Colony of New South Wales, at Government House, Sydney, in New South Wales, this sixteenth day of January, in the year of our Lord one thousand eight hundred and eighty-four.

[L.S.]

AUGUSTUS LOFTUS.

Improvements in Ventilating and Exhaust Fans.

SPECIFICATION of JAMES MORGAN BLACKMAN, of Chicago, in the county of Cook, and State of Illinois, in the United States of America, for an invention entitled "Improvements in ventilating and exhaust fans, and in the application thereof for drying malt and other materials."

THIS invention consists first in a ventilating fan constructed as fully described hereinafter so as to rapidly transmit motion to large volumes of air carrying the same in solid columns without radial or back currents, and in such application of the said fan as will insure the speedy drying of malt and other substances. In the drawing, fig. 1 is a rear view of the improved ventilating fan; fig. 2 is a section on the line 1'2, fig. 1; figs. 3 to 7 are diagrams illustrating the formation of the blades.

Fig. 8 is a perspective view of part of the wheel. Fig. 9 is a perspective view illustrating a modification. Fig. 10 is a transverse section of fig. 9, and fig. 11 is an elevation of a malt house showing an exhaust fan applied thereto. Fans of ordinary construction, while they will propel volumes of air forward by their revolution, will also throw off radially, and still others will be thrown backward instead of forward as desired, creating currents, interfering with the free flow of air to the fan, and detracting from the desired result, so that the current is so weak that it cannot be advantageously employed in drying malt and other materials where a large column of air must be kept in motion through a porous mass. In the improved fan hereinafter described the blades carry or revolve within a peripheral ring, frame, or section, and this prevents the radial flow of the air, thus compelling large volumes, ordinarily dissipated in this direction, to move directly forward. It is necessary to so construct each blade of the wheel as to draw or deflect outward the air from the advancing face of every portion of the blade, and to set every portion or face of the blade at such an angle that the advancing face at every point will cut under the air rather than move it laterally or carry it with the wheel. It is advisable to vary the angle and curve of the blade at different points, although such angles and curves will be different according to the sizes of the wheels and number of the blades, there were certain definite and specific proportions, and forms common to all which result in much improved effects. Thus the hub A of the wheel may be solid or may consist of discs *a a* secured to the shaft B.

From the hub at the front extend ribs *b*, which meet an annular rim *c* and ribs being all in the same vertical plane *x x*. The diameter of the hub A and the depth of the wheel should, to secure the best result, be about equal to about one-sixth of the diameter of the wheel, and the outer ribs or edges *b*, instead of being radial, should be set to coincide with a line somewhat tangential to the hub, so as to dip or pitch forward to prevent radial dispersion of the air as described hereinafter. The blades are set to join the hub upon lines *y y* crossing the axial line at an angle at the centre, and the inner but advancing edge of each blade corresponds to a curve which is preferably gradually increased towards the outer end, these inner edges of all the blades being upon a plane *z z*, parallel to the plane *x x*. Thus the advancing inner edge of each blade may be a rib *e* extending from the hub nearly parallel for a short distance with the rib *b*, and then curved forward, until it nears the periphery, where the curve is sharper, as shown. The body of the blade between the edges of the ribs *b e* is gradually bent at an angle which becomes more and more obtuse to the axis of the shaft as it approaches the periphery (as shown in fine lines, fig. 3), and is also gradually more and more curved from the junction with the edge rib *b*, towards the edge rib *e*, as shown in dotted lines fig. 1. At the periphery the blade is bent to form a peripheral section *d* that extends from the blade to the rim *e*, and has a forward edge *f*, parallel to the axis of the shaft.

This peripheral may form part of the blade, or may be a separate piece riveted or otherwise secured thereto, and may be carried by the blades or may be separate therefrom, as hereinafter described. It will be seen that the wide end *f* of each peripheral section extends to the contracted end of the next section. If the blade was bent or hollowed from each end to the centre, as shown by the outline fig. 4, the air collected by the ends of the blade, instead of being carried outward, would be drawn to the centre and thrown backward in currents interfering with the flow of air to the wheel. So, if the blades at any point (as at the hub fig. 5) is too nearly parallel with the axis of the shaft, the air, instead of being sent forward, will be carried round with the wheel, and the effect will not be proportioned to the power expended. It is because of the failure to recognise these facts, and of the neglect to properly form all portions of the blade, that ordinary fans are so defective in result. By setting the blade at an angle to the axis as shown in fig. 3, by maintaining the portion near the hub comparatively flat, by bending the body beyond the centre, and by giving a sharper curve thereto near the periphery where it meets the peripheral section, as described, back flow is prevented, and with comparatively little power, movement may be imparted to large volumes of air in one direction and in nearly solid columns. This effect is increased by setting the blade somewhat tangential to the axis, as described, instead of radially, the outward end thus being pitched forward so as to draw in the air instead of dispersing it radially.

This will be best understood on reference to diagrams figs. 6 and 7, in which diagram 6 illustrates a radial blade which throws out the air by its revolution, while diagram 7 represents a blade set tangentially to the hub, and tending to draw the air toward the latter. It will be evident that the ribs *b e* may be flanges formed by bending the edge of the blades, or they may be dispensed with. By setting the fan in a case, and back from the wall opening as shown in fig. 2, a fan larger than the opening may be employed, and a better result secured. Where it is not advisable to have the peripheral section *d* carried by the blades (for instance, when a cheaper is needed), the said section may be made part of a stationary frame as shown in figs. 9 and 10, said frame having cross rods supporting bearings *a*, in which turn the journals of the fan shaft B. The structure is thus self-contained, and may be sold as a whole to be set without adjustment of parts in any required position, power to drive the fan being transmitted by a belt to the pulley A. The exhausting fan can be applied generally for purposes of ventilation, drying, &c., and is especially adapted for use in drying large porous masses of material as grain, wool, &c. For drying malt the fan is arranged in the upper part of the malt-house, adjacent to one of the windows, or in a vertical or horizontal position in the cupola, as shown in fig. 11. In such houses it has been customary to blow hot air through the malt on perforated floors, and to stir the grain with mechanical stirrers. Instead of this, an exhaust fan, arranged as described, will draw the air from above the upper floor, so that the air is rarefied and carried in a rarefied condition from the furnace through the perforations of the successive floors, and finally expelled through the opening above the fan.

By

Improvements in Ventilating and Exhaust Fans.

By this means I not only avoid the expense incident to the use of long conducting tubes, but I further avoid the localizing the currents, distributing the air over the whole floor, and lift the grain throughout the entire extent of the floors by carrying the air through rapidly so that there can be little or no condensation of moisture, and the latter is rapidly absorbed into the up-flowing currents, and carried away from the grain. The lifting of the grain by the up-flowing currents of air renders unnecessary the employment of mechanical stirrers, heretofore employed for such purposes, and not only more thoroughly separates the particles and more rapidly and effectually removes the moisture, but is effected without injuring or mashing the particles, liable to result when mechanical means are employed for stirring. Moreover, the whole body of grain on the rectangular floors is stirred, whereas with ordinary stirrers having a circular sweep the corner portions are not effected.

The use of an exhaust apparatus for lifting the grain is important, for it has been found that an exhaust has a much better effect than a blower, as when the air is propelled from below it will seek the easiest passage out, and loses force from leakage in the walls, &c., whereas when an exhaust is arranged above the floors slight leaks have no detrimental effect. It is not new to pass grain, &c., in drying over perforated screens through and over which hot air is carried, and exhaust fans are used for this purpose as well as for drawing air over grain upon malt floors, but this invention is distinguished by the fact that mechanical stirrers are dispensed with, and the desired rapid drying effect is secured by lifting and stirring the grain by an upward current produced by an exhaust apparatus.

I claim—

First—A ventilating fan in which radial blades revolve with a curved peripheral rim, as set forth.

Second—A ventilating fan provided with blades having peripheral sections *d*, substantially as set forth.

Third—The combination in a ventilating fan of blades having curved radial sections and peripheral sections, substantially as specified.

Fourth—A ventilating fan provided with blades, each set upon the hub at an angle to the axis of the shaft, the outside edges of the blades being straight and the inside edges being curved, the curve increasing at the periphery; and having peripheral sections extending to the plane of the outside edges, substantially as set forth.

Fifth—A ventilating fan provided with blades with the outside straight edges on one plane, and the inside curved edges on a parallel plane, the body of each plane being curved to meet a peripheral section *d*, the curve widening or extending from the outer edge to the inside, substantially as set forth.

Sixth—A ventilating fan provided with blades curved as set forth and set on the hub to have a forward pitch, substantially as specified.

Seventh—A ventilating fan in an opening in a case *W*, arranged opposite an opening in a wall or frame, as set forth.

Eighth—A ventilating apparatus consisting of a fan having blades and peripheral sections and carried by a shaft, and an annular rim, enclosing the fan, and open at front and rear, substantially as set forth.

Ninth—The combination of the fan, annular frame, and bearings for the fan-shaft carried by arms extended to the frame, substantially as specified.

Tenth—The within-described improvement in drying malt and other materials, the same consisting in drawing currents of warm air upward through the body of material in such manner as to lift and separate the particles thereof.

Eleventh—The combination with the perforated floors of a drying-house and with the furnace thereof of an exhaust apparatus communicating with the space above the upper floor, and constructed and provided with operating mechanism as set forth, whereby the air above the malt is rarefied, and the particles of material are lifted and separated by and exposed to rapidly ascending warm-air currents, as specified.

Twelfth—The novel construction and arrangement of ventilating and exhaust devices herein-before set forth.

In witness whereof, I, the said Joseph Morgan Blackman, have hereto set my hand and seal, this seventeenth day of November, one thousand eight hundred and eighty-three.

J. M. BLACKMAN,
(By his Agent, EDWD. WATERS).

Witness—

W. S. BAYSTON, Patent Law Clerk, Melbourne.

This is the specification referred to in the annexed Letters of Registration granted to James Morgan Blackman, this sixteenth day of January, A.D. 1884.

AUGUSTUS LOFTUS.

REPORT.

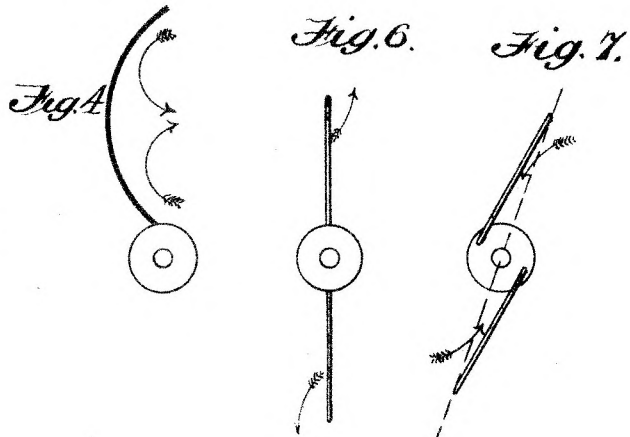
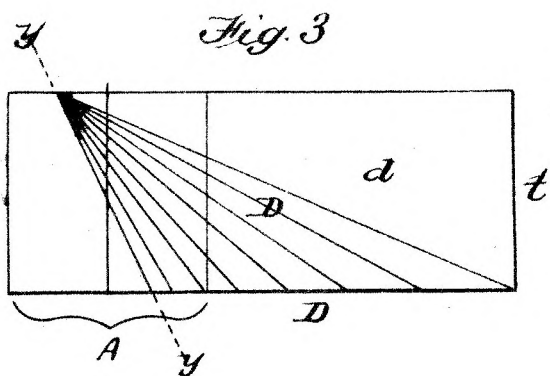
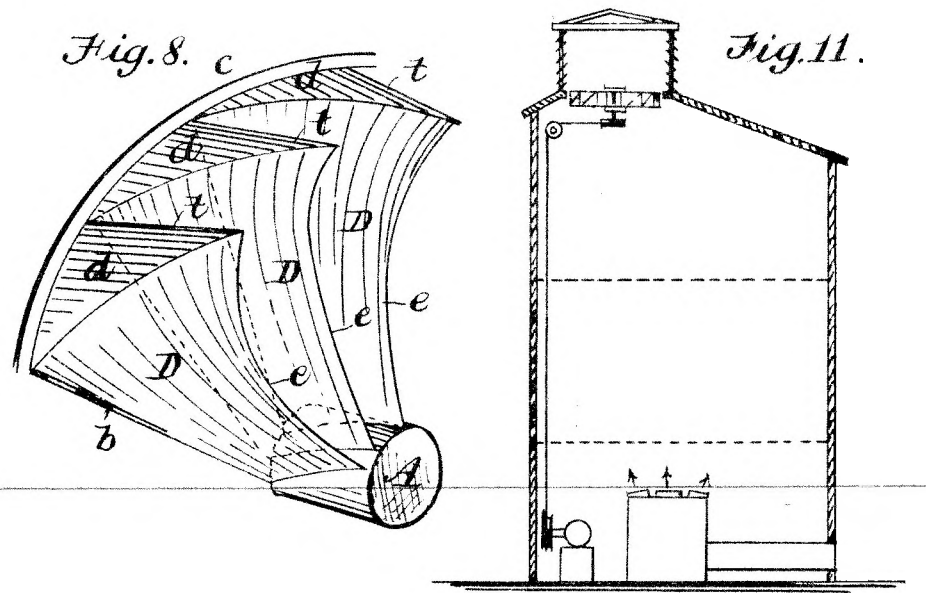
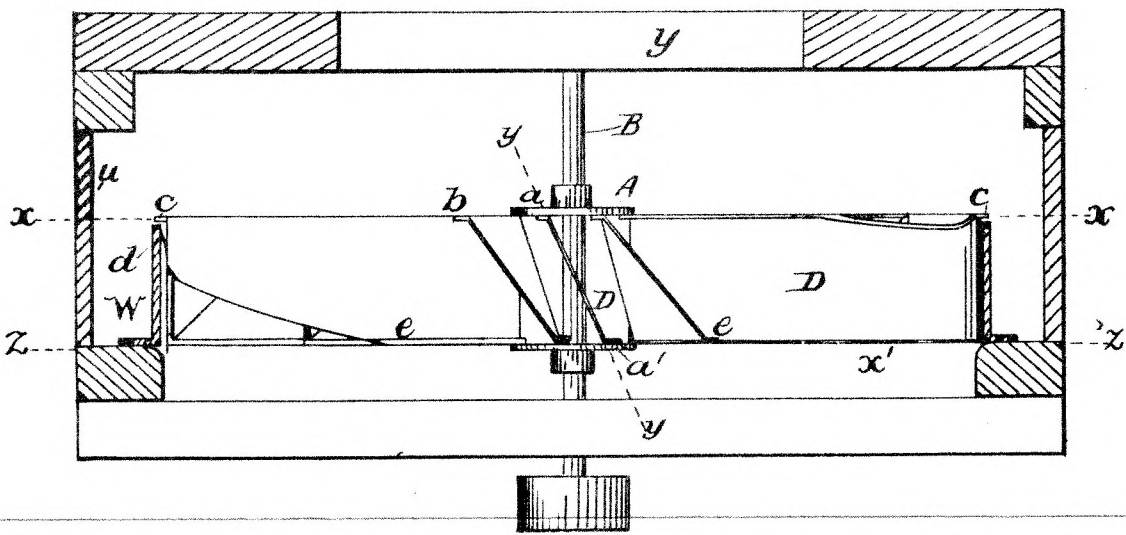
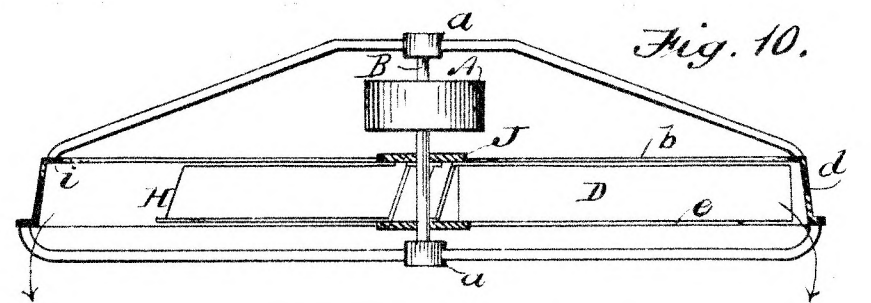
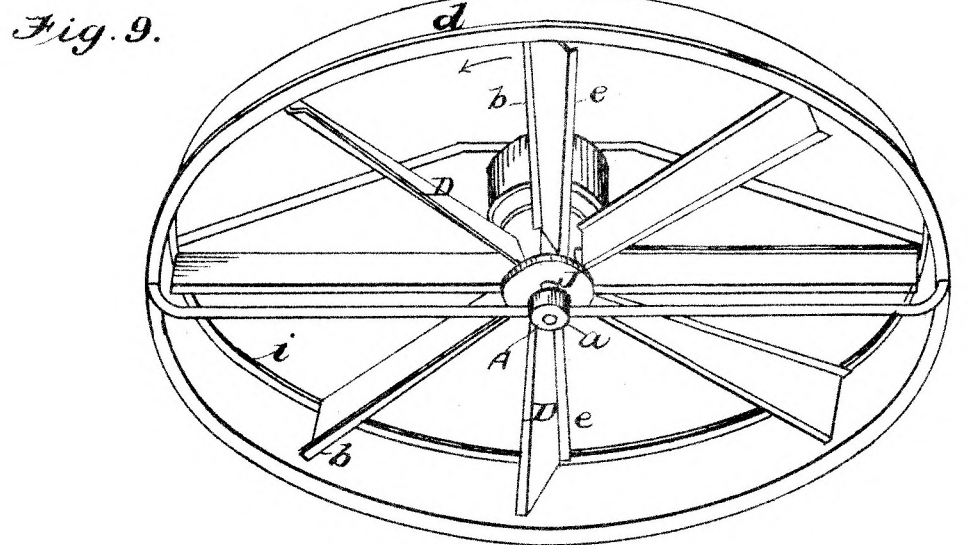
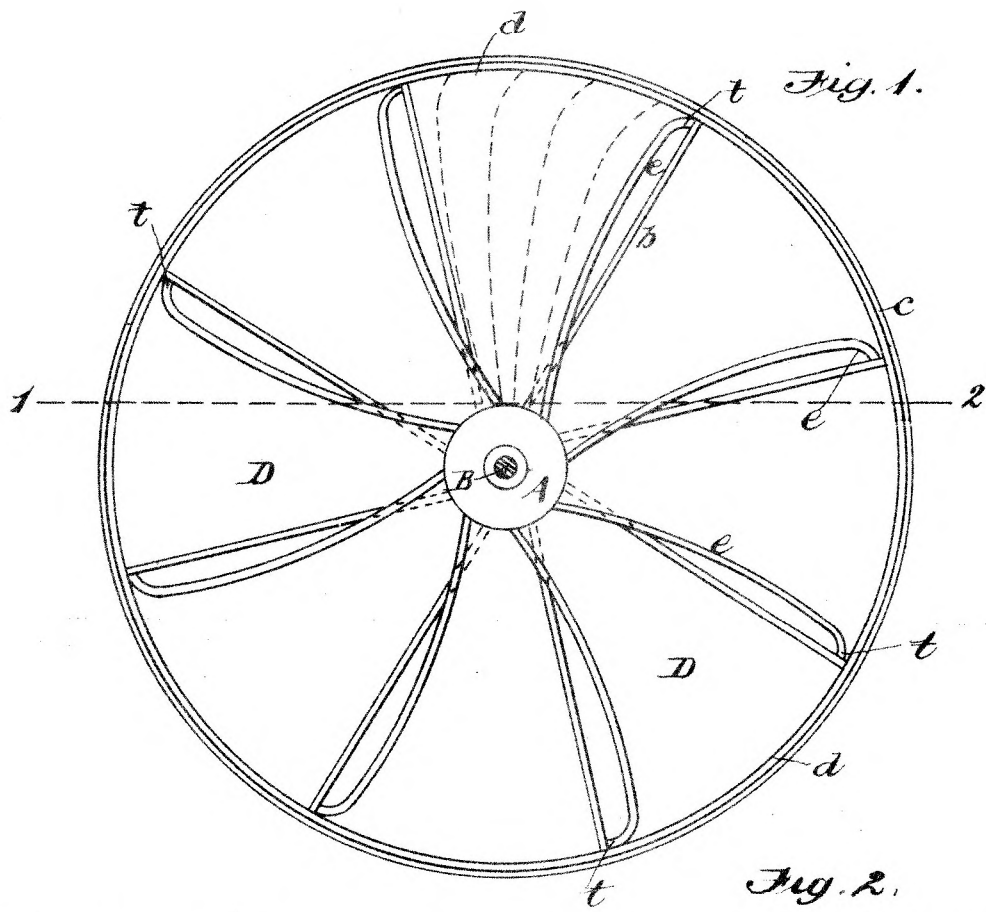
Sir,

The application of Mr. J. M. Blackman, for Letters of Registration for an invention entitled "Improvements in ventilating and exhaust fans, and in the application thereof for drying malt and other materials," having been referred to us for report, we have examined the plan and specification accompanying the same, and have now the honor to report that we see no objection to the issue of Letters of Registration as applied for.

The Under Secretary of Justice.

Sydney, 27 November, 1883.

We have, &c.,
THOS. RICHARDS.
ARCH. FRASER.



(Sig 245-)

This is the Sheet of Drawings referred to in the annexed Letters of Registration granted to James Morgan Blackman this sixteenth day of January AD, 1884.

Augustus Loftus



A.D. 1884, 16th January. No. 1365.

IMPROVED QUARTZ CRUSHER OR MILL.

LETTERS OF REGISTRATION to Horatio Sutherland, for an Improved Quartz Crusher or Mill, to be used for Crushing and Pulverizing Quartz and other Minerals and Materials.

[Registered on the 17th day of January, 1884, in pursuance of the Act 16 Vic. No. 24.]

BY HIS EXCELLENCY THE RIGHT HONORABLE SIR AUGUSTUS WILLIAM FREDERICK SPENCER LOFTUS (commonly called LORD AUGUSTUS LOFTUS), Knight Grand Cross of the Most Honorable Order of the Bath, a Member of Her Majesty's Most Honorable Privy Council, Governor and Commander-in-Chief of the Colony of New South Wales and its Dependencies.

TO ALL TO WHOM THESE PRESENTS SHALL COME, greeting :

WHEREAS HORATIO SUTHERLAND, of 66, Holborn Viaduct, in the City of London, England, hath by his Petition humbly represented to me that he is the author or designer of a certain invention or improvement in manufactures, that is to say, of an invention entitled "An Improved Quartz Crusher or Mill, to be used for Crushing and Pulverizing Quartz and other Minerals and Materials," which is more particularly described in the specification and the sheet of drawings which are hereunto annexed; and that he, the said Petitioner, hath deposited with the Honorable the Treasurer of the said Colony of New South Wales the sum of Twenty Pounds sterling, for defraying the expense of granting these Letters of Registration, as required by the Act of Council, sixteenth Victoria, number twenty-four; and hath humbly prayed that I would be pleased to grant Letters of Registration, whereby the exclusive enjoyment and advantage of the said invention or improvement might be secured to him for a period of fourteen years: And I, being willing to give encouragement to all inventions and improvements in the arts or manufactures which may be for the public good, and having received a report favourable to the prayer of the said Petition, from competent persons appointed by me to examine and consider the matters stated therein and to report thereon for my information, am pleased, with the advice of the Executive Council, and in exercise of the power and authority given to me by the said Act of Council, to grant, and do by these Letters of Registration grant unto the said Horatio Sutherland, his executors, administrators, and assigns, the exclusive enjoyment and advantage of the said invention or improvement, for and during the term of fourteen years from the date hereof; to have, hold, and exercise unto the said Horatio Sutherland, his executors, administrators, and assigns, the exclusive enjoyment and advantage thereof, for and during and unto the full end and term of fourteen years from the date of these presents next and immediately ensuing, and fully to be complete and ended: Provided always, that if the said Horatio Sutherland shall not, within three days after the granting of these Letters of Registration, register the same in the proper office in the Supreme Court, at Sydney, in the said Colony of New South Wales, then these Letters of Registration, and all advantages whatsoever hereby granted, shall cease and become void.

In witness whereof, I have hereunto set my sign manual, and have caused the present Letters of Registration to be sealed with the seal of the said Colony of New South Wales, at Government House, Sydney, in New South Wales this sixteenth day of January, in the year of our Lord one thousand eight hundred and eighty-four.

[L.S.]

AUGUSTUS LOFTUS.

Improved Quartz Crusher or Mill.

SPECIFICATION of HORATIO SUTHERLAND, of 66, Holborn Viaduct, in the City of London, England, for an invention entitled "An Improved Quartz-crusher or Mill, to be used for Crushing and Pulverizing Quartz and other Minerals and Materials."

THIS invention has for its object an improved quartz crusher or mill, to be used for crushing and pulverizing quartz and other minerals and materials.

The improved crusher or mill consists of two main parts—one a cast-metal block with a cavity in it in form like a mortar, and the other another cast block like a pestle. The latter is contained within the former, and nearly fits it, except as hereinafter stated.

The first block is stationary, and an axis passing up through its centre and driven by water or steam power, or in any convenient manner, carries the second block.

The upper parts of the two blocks are corrugated where their surfaces are opposed, and the corrugations, which may be either vertical or inclined, are formed upon rings, which are capable of being removed, in order that the rings may be replaced by others when they become worn. The corrugations are large at the upper parts of the rings, where the material fed into the crusher or mill first comes into contact with them, but become smaller as they descend. Intermediate corrugations are introduced into the spaces then left between the main corrugations.

There is a space or interval between the blocks of about the same depth as the rings, and this is about half the height of the inner block. This space or interval is comparatively wide all around at the top, where the material enters, and becomes narrower in descending, tapering away to nothing at the lower edges of the rings. Below this, the inner block fits to the outer, except at the bottom, around the axis. Here, the inner block is recessed to leave a cavity, and the outer block is perforated with passages communicating with the cavity. By these passages the quartz or material, when reduced sufficiently small, passes out of the apparatus.

A number of indentations may also be formed on the lower part of the inner block. These are useful where the material to be treated contains hard and soft portions, as the hard material becomes embedded in the indentations, and aids in reducing the other and softer parts. The axis is supported at the bottom upon a spring, and is set down at the top by an adjustable screw-pivot. The upper block can thus be confined, more or less closely, against the lower block, according to the degree of fineness to which it is desired that the materials should be reduced.

In order that my said invention may be most fully understood, and readily carried into effect, I will proceed to describe the drawings hereunto annexed:—

DESCRIPTION OF THE DRAWINGS.

Fig. 1 is a side elevation of my improved crusher or mill.

Fig. 2 is a plan of the same.

Fig. 3 is a vertical section, and fig. 4 is a horizontal section on the line A B in fig. 3.

A and B are the two main parts. A is the outer concave mortar-like part, and B is the inner convex pestle-like part.

The part A is bolted to, and carried by, the standards C C of the frame. It may in some cases, for convenience of transport, be cast in two pieces, to meet and be bolted together about on the line A B in fig. 3, or (as these drawings represent) the principal casting may be all of a piece. The part A receives within it a chilled cast-iron or steel ring *a*, so formed that it will drop freely into its place. It is compelled, however, to rotate together with the main casting by ribs upon the one part, which enter and engage with grooves on the other. Upon the exterior of the ring *a* ridges or corrugations are provided. These, as they appear at the upper part of the ring, are seen in fig. 2. As they are continued downwards, the corrugations taper away, and, at the lower edge of the ring, they disappear, the ring *a*, on its lower edge, being truly circular within. Between these main corrugations other secondary corrugations are introduced. They rise gradually from the hollows between the main corrugations, and extend from the middle of the ring to its lower edge. They are similar in form to the lower parts of the main corrugations, and occupy positions midway between them.

When the ring *a* becomes worn, it can readily be removed and replaced by a new ring, with little loss of time and at a small cost.

a' a' are holes. They are formed at the base of a rising part or projection in the centre of the bottom of the part A, where the pestle part B does not closely fit.

The ground or reduced quartz or material passes out from the apparatus by these holes *a'*, and may be, in some cases, aided in doing so by a stream of water introduced at the top, between the parts A and B. The part B is cast with a passage through it, into which the vertical shaft D is received. It is fixed firmly upon this shaft, which, for a portion of its length, is square. The part B is provided with a ring *b*, similar to the ring *a*, but with exterior corrugations. This ring, also, when it becomes worn, is intended to be removed and replaced by a new ring.

The shaft D passes by a circular hole through the bottom of the part A, and is stepped into a cup-bearing, which is carried upon the top of the spring E. The spring E is sufficiently strong to sustain the shaft D and the parts upon it in such a position that the part B does not rest by its weight upon the part A; but the shaft can be set down to any extent desired by a screw F, passing through a cross-bar, which connects the standards C C. The screw bears upon the top of the shaft D, and by means of it the apparatus may be set to obtain any desired degree of reduction of the quartz or material passed through. G is another cross-bar of the frame, on which there is a bearing to support the shaft D. H is a bevelled wheel upon the shaft near its upper end. I is a bevelled pinion, in gear with the wheel H. It is fixed upon the horizontal axis K, and this is carried by the frame in the manner indicated. On the axis K also are pulleys K¹ K¹, to receive a driving-belt. By this belt power is transmitted to the machine from any convenient motor, the axis K being made to rotate, say, at a speed of three hundred revolutions in the minute. L is a fly-wheel upon the axis K. A shield M, seen in fig. 3, is provided. It covers the part B, and is inclined in such manner as to direct the material thrown upon it, and which has previously been reduced to pieces of a suitable size, into the space between the main crushing parts of the mechanism.

Improved Quartz Crusher or Mill.

N is a stationary covering ring, to prevent portions of the material from being projected out from between the crushing parts.

Sometimes I provide, in the lower parts of the castings A and B small cavities of any convenient form, into which hard portions of the material may embed themselves, and so aid in the reduction of softer parts.

Having thus described the nature of my said invention, and the manner of performing the same, I would have it understood that I claim—

First—My improved quartz crusher or mill, substantially as described.

Second—The mortar and pestle parts, A and B, the one revolving in proximity to the other, and both being corrugated at their upper parts, where there is a space between them, and fitting together below, substantially as described.

Third—The mortar and pestle parts, A and B, provided at their upper parts with renewable wearing rings, *a* and *b*, substantially as described.

Fourth—The mortar and pestle parts, A and B, adapted to fit the one to the other at the lower part, except around the centre or axis, where apertures are provided for the escape of the ground or reduced material, substantially as described.

In witness whereof, I, the said Horatio Sutherland, have hereunto set my hand and seal, this twentieth day of September, 1883.

HORATIO SUTHERLAND.

This is the Specification referred to in the annexed Letters of Registration granted to Horatio Sutherland, this sixteenth day of January, A.D. 1884.

AUGUSTUS LOFTUS.

REPORT.

Sir,

The petition of Mr. Horatio Sutherland for Letters of Registration for an invention entitled "An Improved Quartz Crusher or Mill, to be used for crushing and pulverizing quartz and other minerals and materials," having been referred to us, we have examined the specification and drawings accompanying the same, and have the honor to report that we see no objection to the granting of the same.

Sydney, 12 November, 1883.

We have, &c.,

J. SMITH.

A. LEIBIUS.

The Under Secretary of Justice.

[Drawings—one sheet.]

Fig. 1.

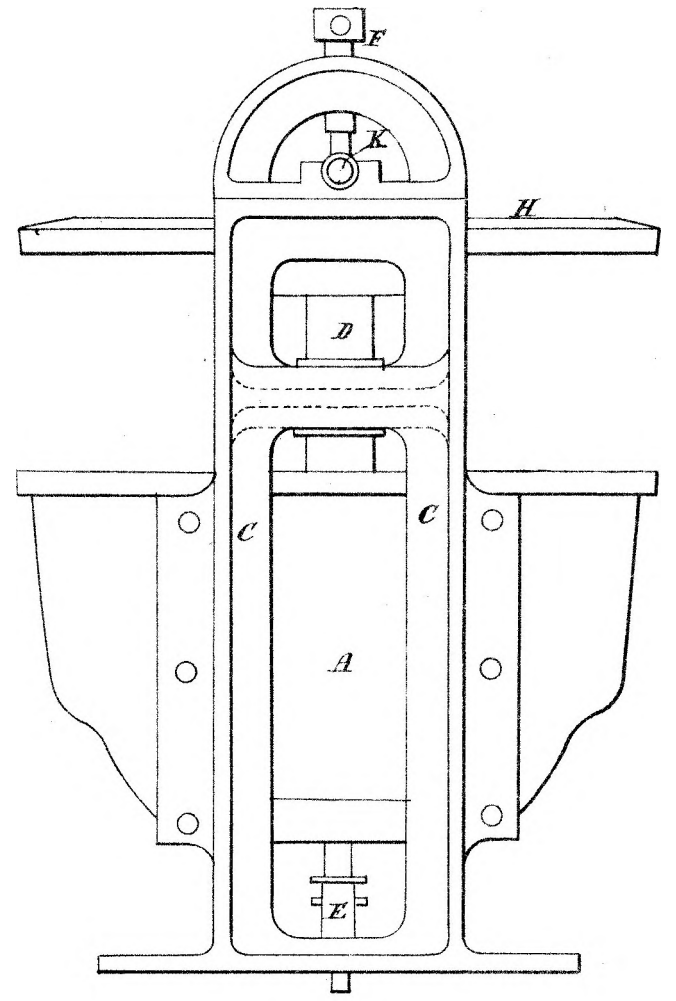


Fig. 3.

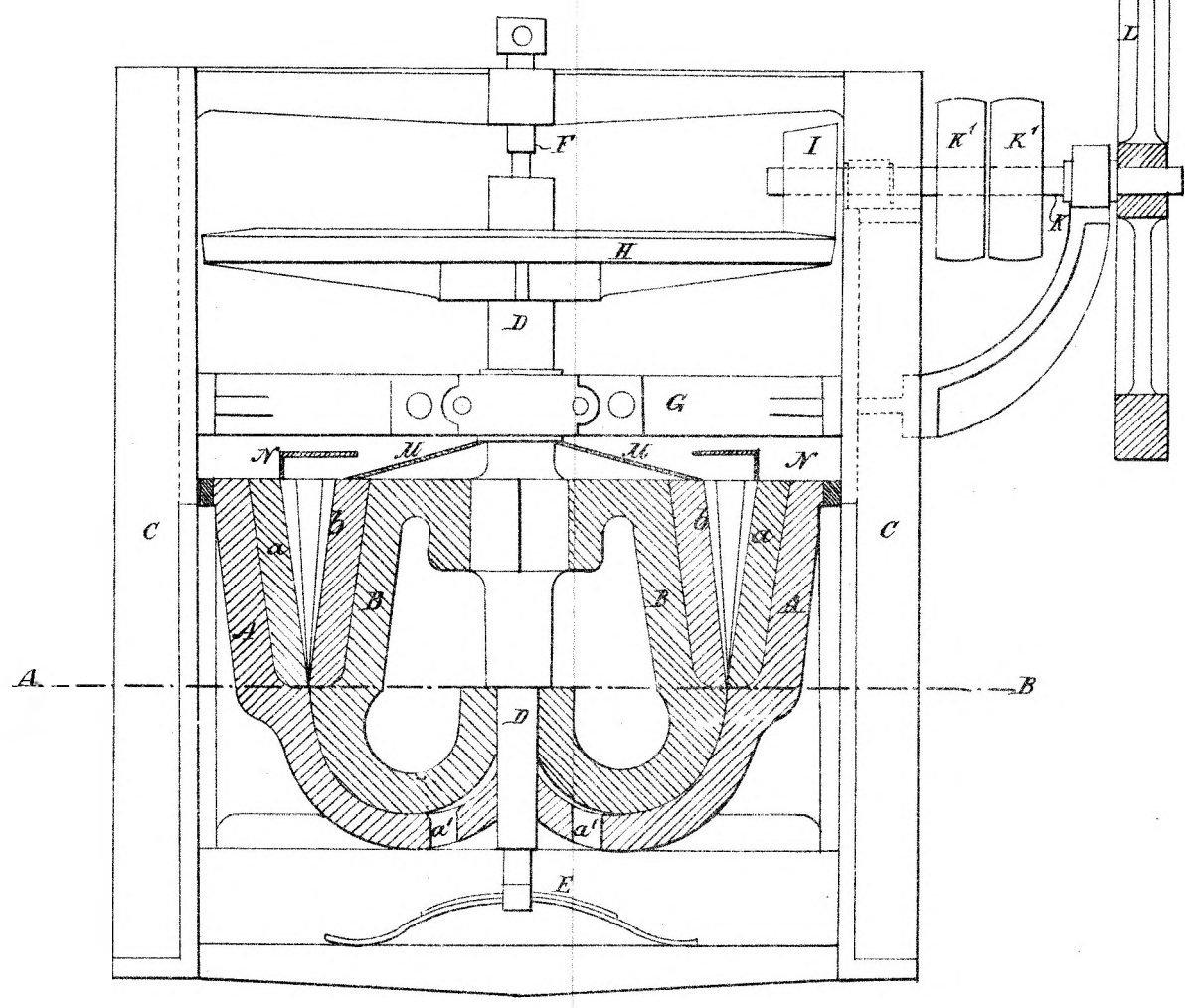


Fig. 2.

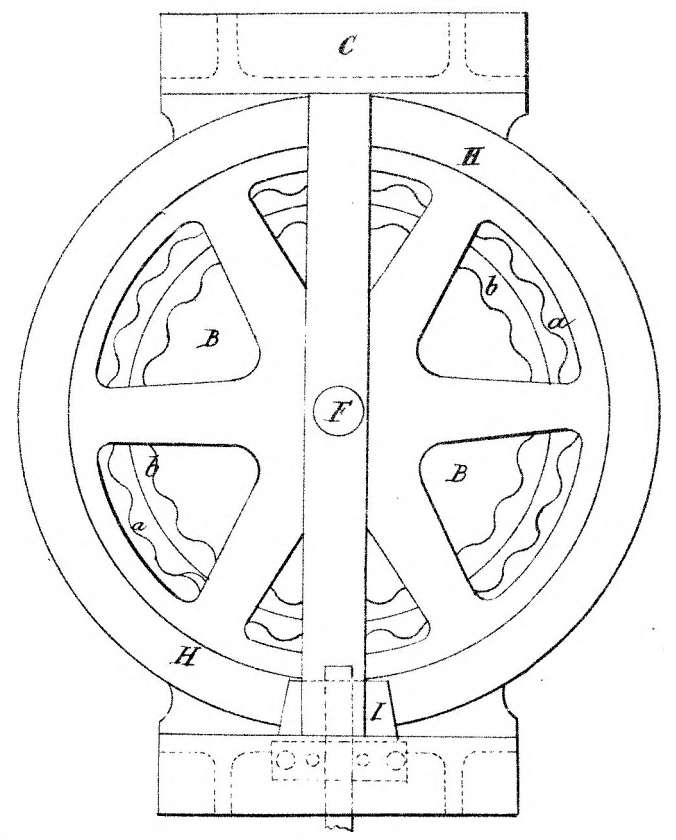
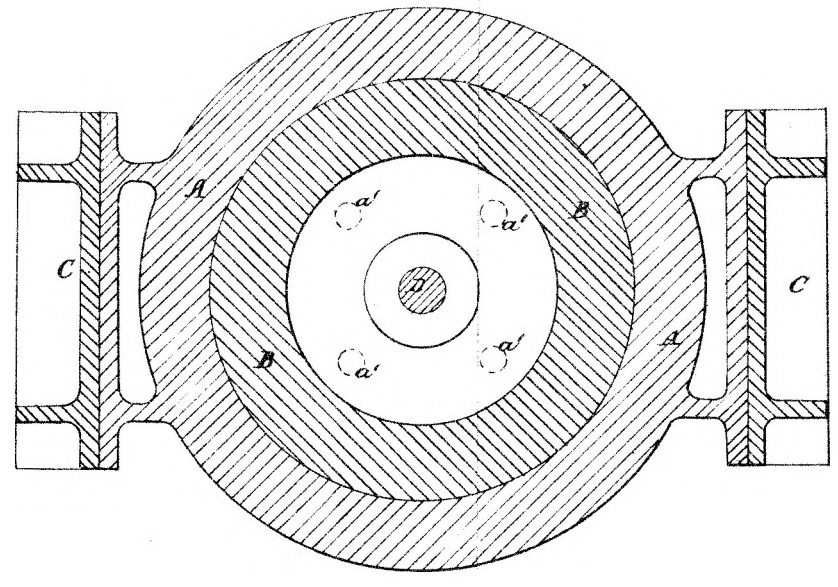


Fig. A.



This is the Sheet of Drawings referred to in the annexed Letters of Registration granted to Horatio Sutherland, this sixteenth day of January, A.D. 1884.

Augustus Lottus.

(Sig 245.)



A.D. 1884, 16th January. No. 1366.

IMPROVED APPARATUS FOR CLEANSING AND SCOURING WOOL.

LETTERS OF REGISTRATION to Potter's Patent Wool-scouring Machine Company of New Zealand (Limited), for Improved Apparatus for Cleansing and Scouring Wool.

[Registered on the 17th day of January, 1884, in pursuance of Act 16 Vic. No. 24.]

BY HIS EXCELLENCY THE RIGHT HONORABLE SIR AUGUSTUS WILLIAM FREDERICK SPENCER LOFTUS (commonly called LORD AUGUSTUS LOFTUS), Knight Grand Cross of the Most Honorable Order of the Bath, a Member of Her Majesty's Most Honorable Privy Council, Governor and Commander-in-Chief of the Colony of New South Wales and its Dependencies.

TO ALL TO WHOM THESE PRESENTS SHALL COME, greeting:—

WHEREAS POTTER'S PATENT WOOL-SCOURING MACHINE COMPANY OF NEW ZEALAND (LIMITED), hath by its Petition humbly represented to me that it is the assignee (so far as the Colony of New South Wales is concerned) of Albert Potter, of Hamilton, New Zealand, who is the author or designer of a certain invention or improvement in manufactures, that is to say, of an invention entitled "Improved Apparatus for Cleansing and Scouring Wool," which is more particularly described in the specification and the sheet of drawings which are hereunto annexed; and that the said Petitioner hath deposited with the Honorable the Treasurer of the said Colony of New South Wales the sum of Twenty Pounds sterling, for defraying the expense of granting these Letters of Registration, as required by the Act of Council, sixteenth Victoria, number twenty-four; and hath humbly prayed that I would be pleased to grant Letters of Registration, whereby the exclusive enjoyment and advantage of the said invention or improvement might be secured to it for a period of fourteen years: And I, being willing to give encouragement to all inventions and improvements in the arts or manufactures which may be for the public good, and having received a report favourable to the prayer of the said Petition, from competent persons appointed by me to examine and consider the matters stated therein and to report thereon for my information, am pleased, with the advice of the Executive Council, and in exercise of the power and authority given to me by the said Act of Council, to grant, and do by these Letters of Registration grant unto the said Potter's Patent Wool-scouring Machine Company of New Zealand (Limited), its successors and assigns, the exclusive enjoyment and advantage of the said invention or improvement, for and during the term of fourteen years from the date hereof; to have, hold, and exercise unto the said Potter's Patent Wool-scouring Machine Company of New Zealand (Limited), its successors and assigns, the exclusive enjoyment and advantage thereof, for and during and unto the full end and term of fourteen years from the date of these presents next and immediately ensuing, and fully to be complete and ended: Provided always that if the said Potter's Patent Wool-scouring Machine Company of New Zealand (Limited), shall not, within three days after the granting of these Letters of Registration, register the same in the proper office in the Supreme Court, at Sydney, in the said Colony of New South Wales, then these Letters of Registration, and all advantages whatsoever hereby granted, shall cease and become void.

In witness whereof, I have hereunto set my sign manual, and have caused the present Letters of Registration to be sealed with the seal of the said Colony of New South Wales, at Government House, Sydney, in New South Wales, this sixteenth day of January, in the year of our Lord one thousand eight hundred and eighty-four.

[L.S.]

AUGUSTUS LOFTUS.

Improved Apparatus for Cleansing and Scouring Wool.

SPECIFICATION of POTTER'S PATENT WOOL-SCOURING MACHINE COMPANY OF NEW ZEALAND (LIMITED), a Company registered in Auckland, in the said Colony, under an Act of the General Assembly of New Zealand, entitled "The Companies Act, 1882," the assignees of Albert Potter, of Hamilton, in the Provincial District of Auckland, in the Colony of New Zealand, Wool-stapler, the inventor of an invention entitled "Improved Apparatus for Cleansing and Scouring Wool."

THE processes and apparatus now in use for cleansing and scouring wool are objectionable for many reasons, not the least of which is that there is great difficulty afterwards in assorting the fleece into lavers of like quality. Now my invention has been designed for the purpose of providing a machine which will remove most if not all of the said objections, and which will especially make the subsequent assortment of wools a comparatively easy operation. It consists in the application of an entirely novel class of apparatus to do the work, viz., stamping or beating apparatus, to stamp or beat the wool when it is in a bath of any suitable liquor, the liquor itself forming no part of my invention, but the apparatus only. After being thus stamped or beaten, I pass the wool between rollers and remove the dirty liquid, and when necessary I return the wool to be restamped or beaten as often as is needful. These rollers also form no part of my invention, as they are commonly used for the same purpose.

The stampers or beaters to be used in my machine may be constructed of any shape and of any material preferred, but I prefer to make them of wood dovetailed into an iron head or cap, and I also prefer to make their stamping faces in the form of a grid or grating, and not solid, as in ordinary stampers. These stampers I also prefer to make with shanks passing through guides, and with any of the well known contrivances for lifting them.

The wool to be stamped or beaten I put into a box or trough of suitable shape and size, and mounted on wheels, which run on a tramway leading on to a platform immediately underneath the stampers or beaters. To this platform I attach a rack worked by a pinion, by which means the platform and the box or trough are raised into position, and then a hinged framing is raised into a vertical position underneath the box or trough, which is then lowered upon it, thus relieving the platform of its load during the process of stamping or beating. The stampers or beaters are then set to work, and when the wool is sufficiently treated the platform is raised again so as to lift the box off its supporting framing (which is swung down on its hinges out of the way), and the box then lowered down on to the tramway, along which it is conducted to the rollers for squeezing out the dirty liquid, as is well understood, and another box containing dirty wool is run along the tramway and lifted under the stampers in the same way as the first.

It is essential to the success of the machine that the stampers or beaters should be so constructed as not to felt the wool or tease or disintegrate it or break its fibre. The stampers or beaters I have described are of this character.

Referring to my drawings,—Figure 1 shows top view of one of my machines, with part of the framing broken away, in order to show the cams and discs more clearly; figure 2, sectional elevation of same on the line A B in figure 1; figure 3, end elevation of same, with part of wooden framing broken away, in order to show the gearing for raising and lowering the box or trough; and figure 4, plan of the bottom of the stampers or beaters. *a a* are the stampers or beaters dovetailed into iron plates *c*, to which are attached stamper shanks *a'* carrying discs *l* and passing through guides *a''*. The lower part of the stamper shanks, and the lower guides through which they pass, are square. Near the top are stoppers *m* to hold up the stampers when the box or trough is removed from underneath. *o o* are the cams which work against the discs *l* for lifting the stampers, as is well understood, and *p p* are pinions for connecting together and simultaneously driving all the cam shafts from the one marked *o'*, which receives its motion from main driving shaft *r*, through the medium of toothed wheel and pinion *r'* and *r''*. *d* is the box or trough for holding the wool, and the liquor in which it is soaked, and *d'* are its wheels which run on tram rails *d''*, *t* is the stem which carries the rack *t'* on its side and platform *t''* at its top. *t''* is the pinion which works said rack, and *k* is a lever attached to spindle of pinion *t''* for giving it the necessary motion. *f f* are the two halves of the swinging framing, each half swinging on a pivot or spindle *f''*, and both being connected by rod *h*, and operated by the one lever *g* as shown. *s s* are guide rollers for the stem *t*. Figure 4 shows the method of arranging the stampers which I prefer—that is with the lines of the grid on the face of the stampers, at right angles to each other.

Referring to my drawings,—Figures 5 and 6 show back and side view (partly in section), and figure 7 plan of rollers or squeezers, as used in connection with my stamping apparatus for cleansing and scouring wool, which rollers are fixed in a convenient position over the tramway, so that the box or trough, which is mounted on wheels and contains the wool (after it has been operated upon by the stampers or beaters), may be brought to the rollers, and the dirty liquor squeezed out. The wool passes through said rollers on to a table at the back of the machine. *d* is the box or trough carried on wheels *d'*, which run on the tram rails *d''*. *r* is the outlet for emptying said box of the liquor when required. *A A* are the rollers which are fixed on shafts *A'* and *A''*, which work in sliding block bearings *A'''*, supported in suitable slotted brackets *A''''*, bolted to the uprights of the framing *V*, as shown. The bearings are adjusted by means of screw pins *A''''''* screwed into the ends of the brackets *A''''*. *B* is the driving pulley, which, together with toothed pinion *B'*, is keyed on to shaft *B''* working in bearings *B'''* bolted to the uprights of framing in front of machine. The pinion *B'* gears into toothed wheel *A''''*, which is keyed on end of lower roller shaft *A''*. At the other ends of the roller shaft *A'* and *A''* the toothed wheels *A''''* and *A''''* are keyed on, thereby communicating motion from the lower to the upper roller shaft. *l* is a sheet iron shoot, fastened to the frame of machine, for conducting the liquor pressed out of the wool back to the box or trough. *Q* is the table for receiving the cleansed wool.

Having thus described the nature of this invention, and the manner in which it is to be performed, I would have it understood that I do not confine myself to the shape or size of any of the parts of my machine, nor to the materials of which they may be made or manufactured, so long as the nature

Improved Apparatus for Cleansing and Scouring Wool.

nature and essence of my invention be retained, although in all these particulars I have stated and shown that which I prefer; but what I believe to be new and useful, and for which I am desirous of securing a patent is—

First—Apparatus for cleansing and scouring wool, in which stampers or beaters are used for stamping or beating the wool when it is soaking in any suitable liquid.

Second—The special form of stampers or beaters herein shown and described for this purpose, viz., with their faces in the form of a grid, as specially shown in figure 4 of my drawings.

Third—The combination of the stem *t*, its rack *t*¹, pinion *t*², lever *k*, and platform *t*³, with the hinged framing *f f*, to be used in the manner and for the purposes herein described and explained.

POTTER'S PATENT WOOL-SCOURING MACHINE COMPANY
OF NEW ZEALAND (LIMITED).

(By their Agent, EDWARD WATERS.)

Witness—

W. S. BAYSTON,
Patent Law Clerk, Melbourne.

This is the specification referred to in the annexed Letters of Registration granted to Potter's Patent Wool-scouring Machine Company of New Zealand (Limited), this sixteenth day of January, A.D. 1884.

AUGUSTUS LOFTUS.

REPORT.

Sir,

The application of Potter's Patent Wool-scouring Machine Company of New Zealand (Limited), for Letters of Registration for an invention entitled "Improved Apparatus for Cleansing and Scouring Wool," having been referred to us for report, we have examined the plan and specification accompanying the same, and have now the honor to state that we see no objection to the issue of Letters of Registration as applied for.

Sydney, 14 November, 1883.

We have, &c.,

ARCH. FRASER.

THOS. RICHARDS.

The Under Secretary of Justice.

Drawings—one sheet.



A.D. 1884, 16th January. No. 1367.

IMPROVEMENTS IN THE MACHINERY OF ELEVATORS.

LETTERS OF REGISTRATION to Norman Selfe, for Improvements in the Machinery of Elevators.

[Registered on the 17th day of January, 1884, in pursuance of the Act 16 Vic. No. 24.]

BY HIS EXCELLENCY THE RIGHT HONORABLE SIR AUGUSTUS WILLIAM FREDERICK SPENCER LOFTUS (commonly called LORD AUGUSTUS LOFTUS), Knight Grand Cross of the Most Honorable Order of the Bath, a Member of Her Majesty's Most Honorable Privy Council, Governor and Commander-in-Chief of the Colony of New South Wales and its Dependencies.

TO ALL TO WHOM THESE PRESENTS SHALL COME, greeting :

WHEREAS NORMAN SELFE, of 141, Pitt-street, in the city of Sydney and Colony of New South Wales, consulting engineer, hath by his Petition humbly represented to me that he is the author or designer of a certain invention or improvement in manufactures, that is to say, of an invention entitled "Improvements in the Machinery of Elevators," which is more particularly described in the specification, marked A, and the three sheets of drawings, marked B, C, and D respectively, which are herewith annexed; and that he, the said Petitioner, hath deposited with the Honorable the Treasurer of the said Colony of New South Wales the sum of Twenty Pounds sterling, for defraying the expense of granting these Letters of Registration, as required by the Act of Council, sixteenth Victoria, number twenty-four; and hath humbly prayed that I would be pleased to grant Letters of Registration, whereby the exclusive enjoyment and advantage of the said invention or improvement might be secured to him for a period of fourteen years: And I, being willing to give encouragement to all inventions and improvements in the arts or manufactures which may be for the public good, and having received a report favourable to the prayer of the said Petition, from competent persons appointed by me to examine and consider the matters stated therein and to report thereon for my information, am pleased, with the advice of the Executive Council, and in exercise of the power and authority given to me by the said Act of Council, to grant, and do by these Letters of Registration grant unto the said Norman Selfe, his executors, administrators, and assigns, the exclusive enjoyment and advantage of the said invention or improvement, for and during the term of fourteen years from the date hereof; to have, hold, and exercise unto the said Norman Selfe, his executors, administrators, and assigns, the exclusive enjoyment and advantage thereof, for and during and unto the full end and term of fourteen years from the date of these presents next and immediately ensuing, and fully to be complete and ended: Provided always, that if the said Norman Selfe shall not, within three days after the granting of these Letters of Registration, register the same at the proper office in the Supreme Court, at Sydney, in the said Colony of New South Wales, then these Letters of Registration, and all advantages whatsoever hereby granted, shall cease and become void.

In witness whereof, I have hereunto set my sign manual, and have caused the present Letters of Registration to be sealed with the seal of the said Colony of New South Wales, at Government House, Sydney, in New South Wales, this sixteenth day of January, in the year of our Lord one thousand eight hundred and eighty-four.

[T.S.]

AUGUSTUS LOFTUS.

Improvements in the Machinery of Elevators.

A.

SPECIFICATION of NORMAN SELFE, of Pitt-street, Sydney, New South Wales, for an invention entitled "Improvements in the Machinery of Elevators."

My improvements apply to elevators employed for lifting either passengers or goods, and are shown on three sheets of drawings, numbered 1, 2, and 3 respectively.

In drawing No. 1, figure 1 is a side view, figure 2 is a plan, and figure 3 a front view of an elevator for stores or warehouses.

A is a freight or platform car for elevating goods by hand power; BB are guide posts; C is the rope or ropes attached to the car by special devices, to be presently described, for hoisting it; D is a spirally grooved winding drum, around which the rope or ropes each make one and a half or more turns.

E is a balance weight attached to the opposite end of the rope or ropes, by preference heavier than the car. When two ropes are used the spiral grooves are made right and left handed respectively, so that as the drum revolves the ropes approach or recede from one another, and the connection to the drum or balance weight is kept central.

F is the main shaft on which drum D is made fast.

G is a spur wheel on F, and H is a spur pinnion gearing with G.

J is the shaft or axle of H, and K is a wheel with a groove shaped to carry the endless hoisting rope or chain by which motion is imparted to the hoists in the usual way. This wheel K has also a rim to act as a brake wheel.

LL are the frames of the machine to carry the shafts F and J. These frames may have bearings made with antifricition rollers instead of the ordinary form. M' M'' are two brake levers suspended from joints; N is a lever with a counterbalance weight jointed to M''.

O is a rod connected to lever F and M' in such a way that as the weight on N rises or falls the levers M' and M'' approach or recede from one another.

P is a sheave in M'', and Q is a rope passing over P and attached to N.

R is a weight on the end of Q so proportioned to the weight on N that when R is lifted by the rope Q, N will fall, and with its weight bring M' M'' together with a pressure sufficient to stop the wheel K from revolving, while at the same time R is heavy enough to keep N up with its weight when Q is pulled down and N drawn up.

S' S'' are rods to keep the joints of M' M'' from separating by the pressure of the brakes on wheel K.

In drawing No. 2, figure 1, is an enlarged side view of part of LL in drawing No. 1; figure 2 is a section of the same; J is the shaft or axle of the hoist; L is the main casting accurately bored out; T to T are rollers filling up the space between J and L, and working freely at sides and ends; V to V are secondary rollers made with projecting gudgeons at the ends.

X is a cover or gland to retain the rollers in L.

W' W'' are grooves in L and X, in which the gudgeons of V to V are so disposed that the secondary rollers are kept in the straight lines joining the centres of main rollers, and kept from touching J or L.

Figures 3, 4, and 5 are enlarged views of the head of bar A in drawing No. 1; figures 6 and 7 are sections of the same.

a' a'' is the cross-head of the car, generally made of two fitches of timber side by side with a space between; b' b'' are the sides of the car attached to a' a''; c' c'' are the guide posts or runners; d' d'' are plates or washers on a' a''; e is the main suspension eyebolt of the car, working freely in d' d''; f is a nut on e which lifts the car when drawn up against d''; g' g'' are eyebolts securing d' d'' to a' a''; h' h'' are two levers working on centres in g' g'', being loosely attached to e at their inner ends; j' j'' are springs attached to h' h'', in such a way as to pull down the inner ends of the levers and eyebolt e, and elevate the outer ends; k' k'' are shafts extending across the cage; l' l'' l''' l'''' are eccentric grippers with serrated faces keyed on to k' k'', in such a way as to tightly grip guide posts c' c'' when in a certain position; m' m'' m''' m'''' are fingers or cams fast on k' k'', and resting on outer ends of levers h' h''; n' n'' n''' n'''' are the bearings of shafts k' k'', strongly connected to a' a''; o' o'' are shackles for the attachment of balance-weight ropes, when the springs j' j'' may be dispensed with. The whole combination is so arranged that when the car is lifted by means of a rope or chain attached to e the nut f is drawn up against the plate d'' and the car is lifted, while at the same time the outer ends of the levers h' h'' allow the fingers m' m'' m''' m'''' to drop, and the grippers l' l'' l''' l'''' to keep free from the guides c' c'', as shown in figures 3, 4, and 6; while, should the rope attached to e break, the springs acting on inner ends of h' h'', or the upwards pull of the balance-weight ropes on o' o'' at the outer ends of same, will move the levers, turn the shafts, and throw the grippers l' l'' l''' l'''' into action against the guides.

In drawing No. 3, figures 1 and 2 are enlarged views of the brake shown in the drawing No. 1, and figures 3 and 4 are slight modifications of the same.

p is the brake wheel; q' q'' are brake levers; i' i'' are the joints for attachment of q' q'' to eyebolts; s' s'' are straining rods to keep i' i'' from being separated; t is a lever jointed to q''; u is a rod connecting t and q'; v is a weight on t; w is a rope attached to t; x is a weight suspended from w.

In figures 1 and 2 it is necessary for the attendant to pull the rope w to take off the brake, or to lift up the rope and lower weight v to put on the brake; but in figures 3 and 4 this is reversed, and the relative proportions of the weights are reversed, so that pulling the ropes down puts on the brake, and lifting it up allows the weight v to take it off. The weights and levers are so proportioned that any strain desired can be put on the brake wheel, and when the brake is put on or off it will keep in that state until the rope is pulled up or down again, as required.

Although my improvements are more particularly applicable to elevators worked by hand, I can apply them to elevators worked by other power. I do not claim to have originated all the details shown in the drawings, but what I do claim as novel and ask protection for, is:—

- 1st. The application of antifricition bearings to elevators, so as to reduce the friction of the shafts and allow a slight excess of counterbalance weight to run the empty car up to top of hoist.

2nd.

Improvements in the Machinery of Elevators.

- 2nd. The application of a double spiral drum to a hand elevator, in such a way that the rope is gripped without being jammed in a V groove, and the lift is kept central over the car and the balance weight.
- 3rd. The construction of a safety gear with four grippers on two shafts, in such a way that on the failure of the hoist ropes they will all be thrown into action by either one of the springs or counter-balance ropes, substantially as described.
- 4th. The construction of a brake gear by an arrangement of levers and balance weights, in such a way that the brake can be put on and left on, or put off and left off, by the operation of one rope only, arranged substantially as described.

NORMAN SELFE.

This is the specification marked A referred to in the annexed Letters of Registration granted to Norman Selfe, this 16th day of January, A.D. 1884.

AUGUSTUS LOFTUS.

REPORT.

Sir,

Sydney, 18 November, 1883.

In accordance with your B.C. minute of the 13th instant, on Mr. Norman Selfe's application for the issue of Letters of Registration for an invention entitled "Improvements in the Machinery of Elevators," we have to report that we see no objection to the granting of the protection applied for.

We have, &c.,

JAMES BARNET.

WILLIAM C. BENNETT.

The Under Secretary of Justice.

[Drawings—three sheets.]

B

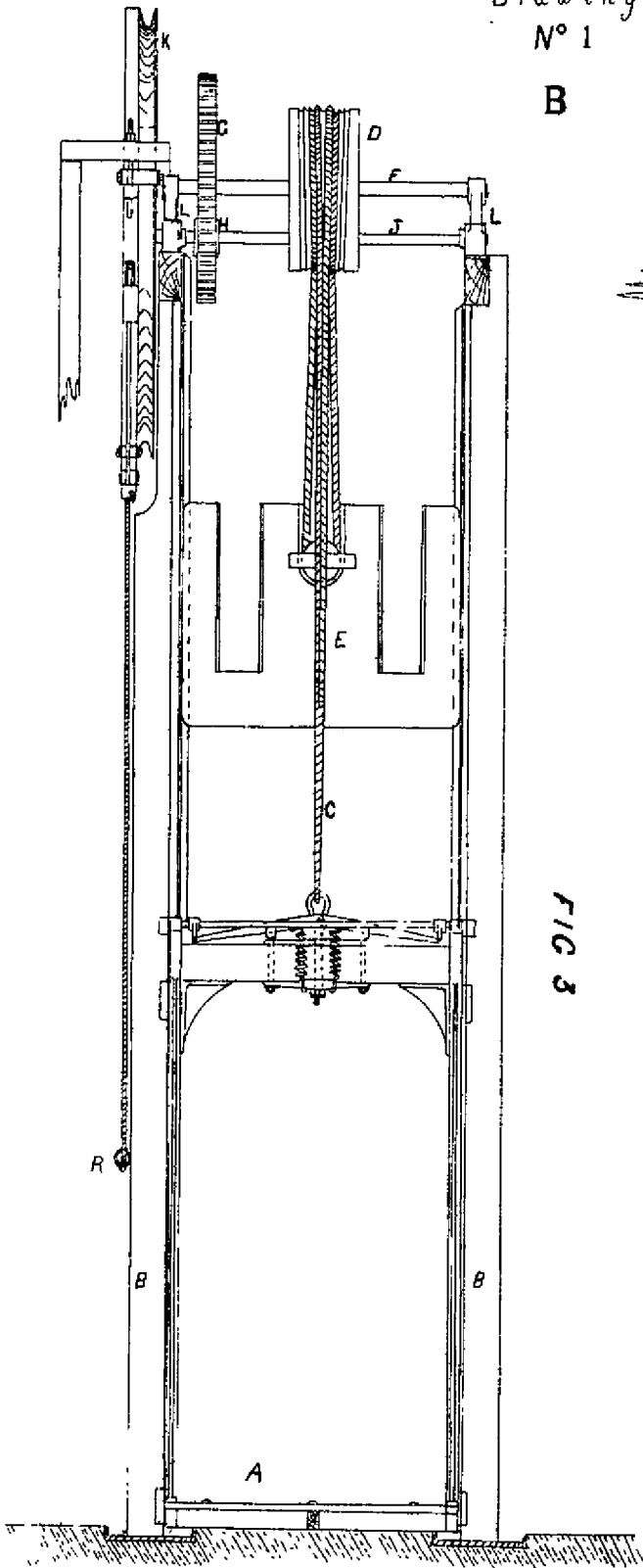


FIG 3

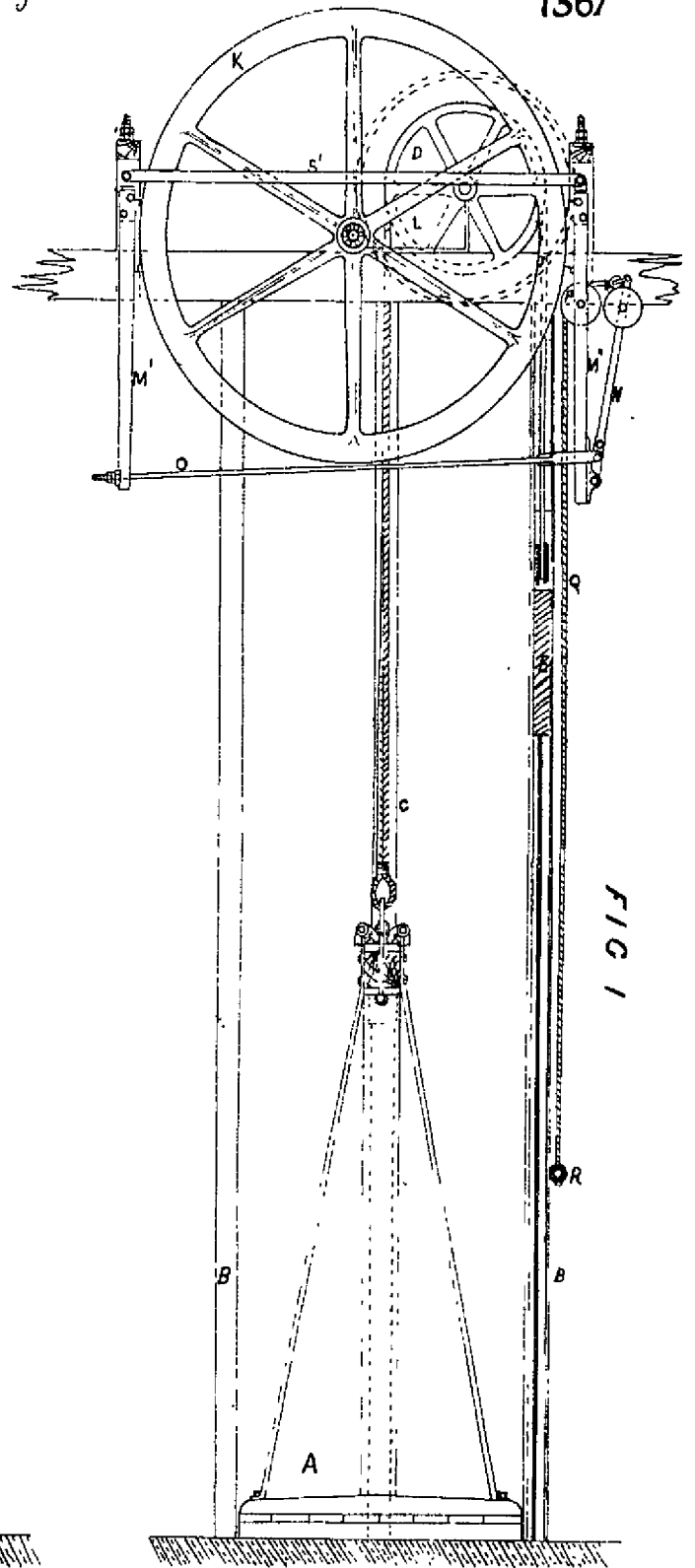


FIG 1

*This is the Sheet of Drawings Marked B preferred, to in the annexed
Letters of Registration granted to Norman Selfe, this sixteenth
day of January, AD, 1864.*

Augustus Loftus

(Sig: 245-)

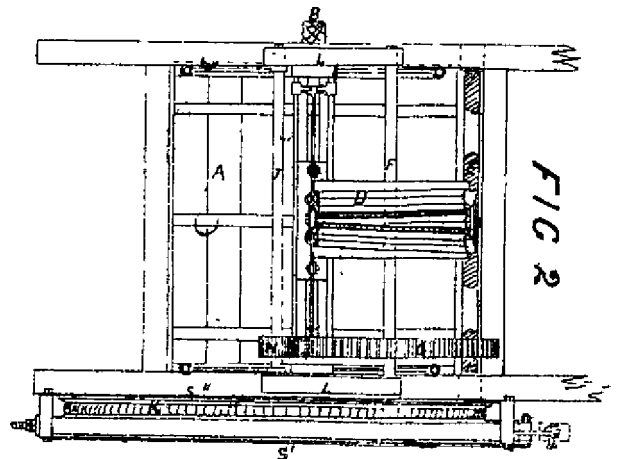
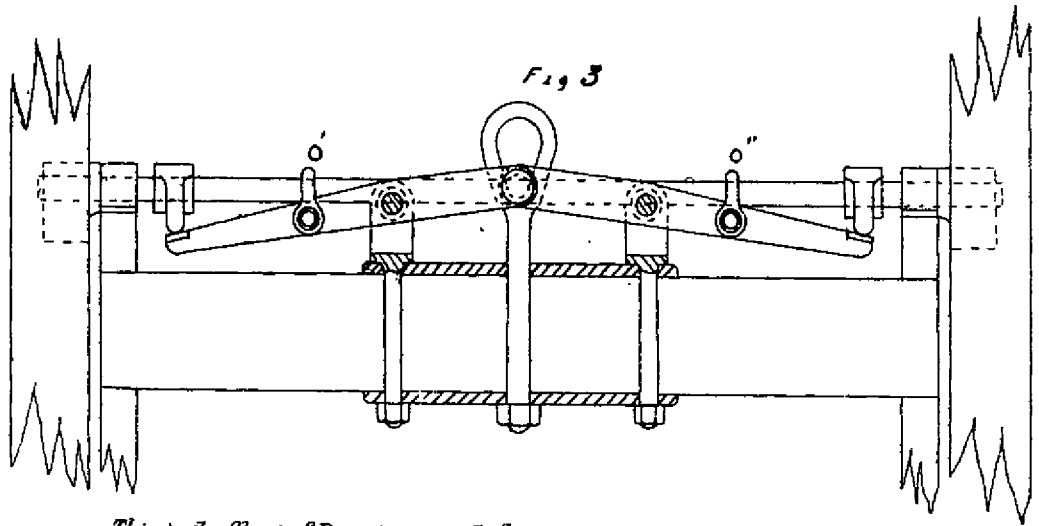
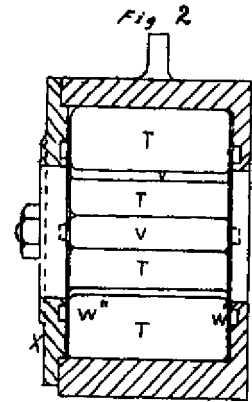
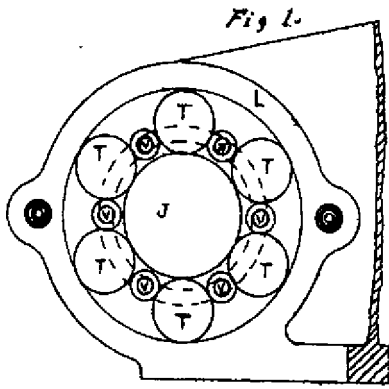
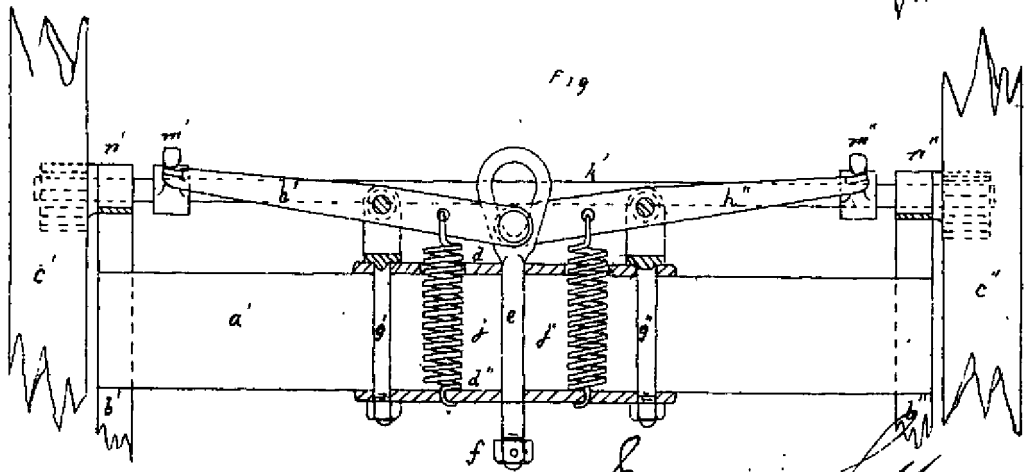
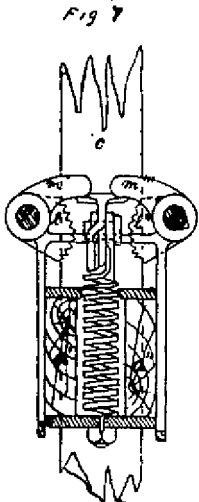
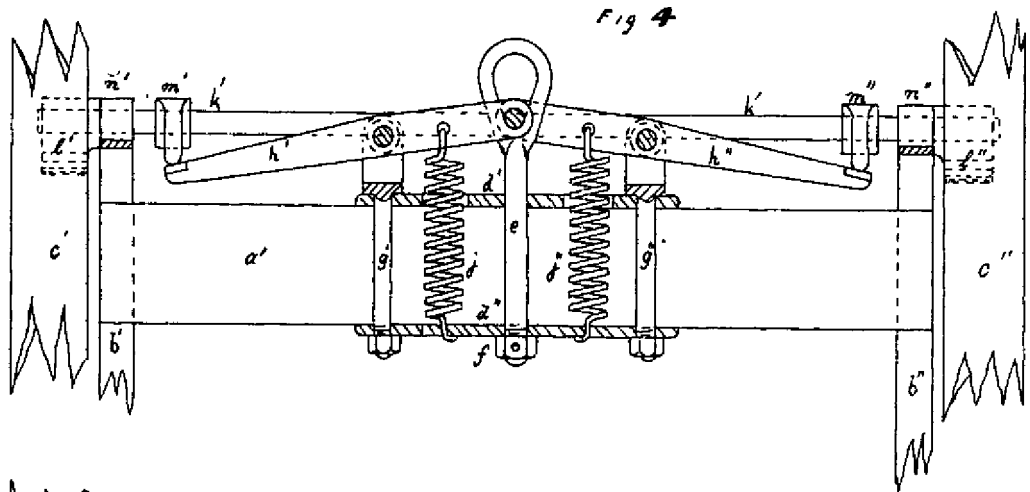
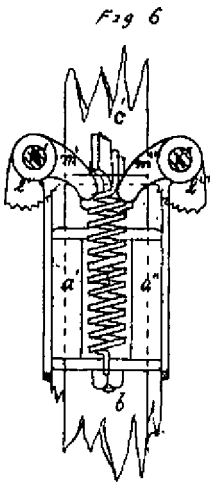


FIG 2



*This is the Sheet of Drawings marked C, referred to in the annexed
Letters of Registration, granted to Norman Selfe, this sixteenth
day of January, A.D., 1884.* Augustus Loftus.



(Sig: 245.)

Norman Selfe.

1367

Drawing

Nº 3

D

Fig 1

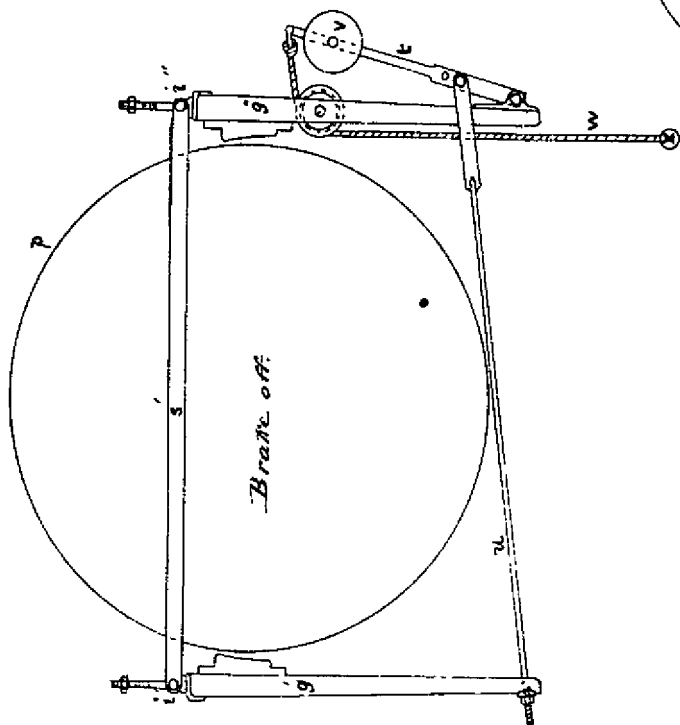


Fig 2

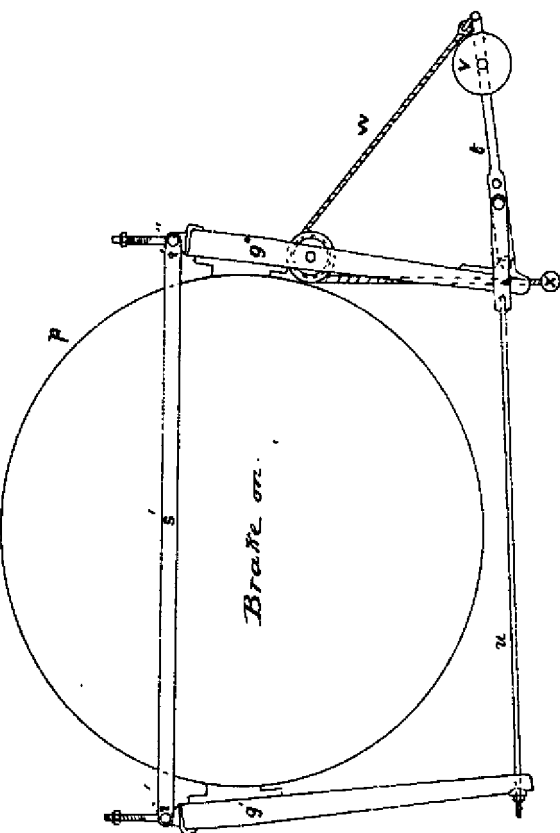


Fig 3

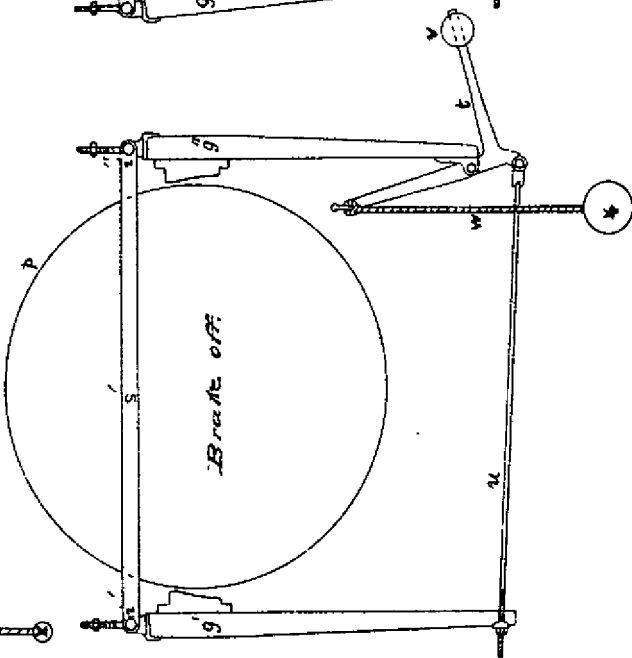
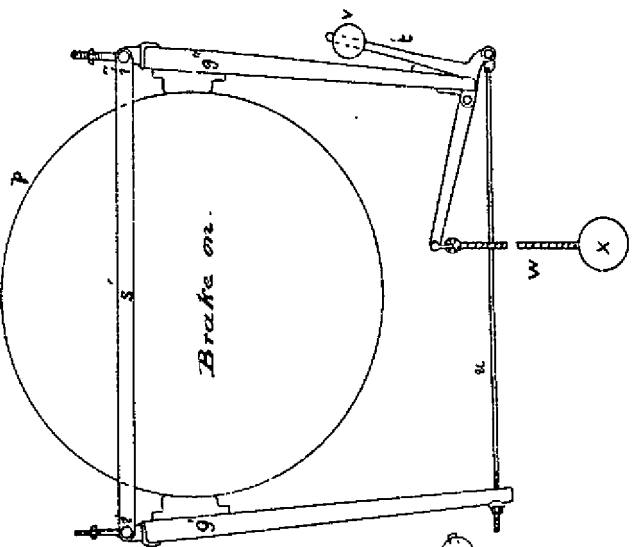
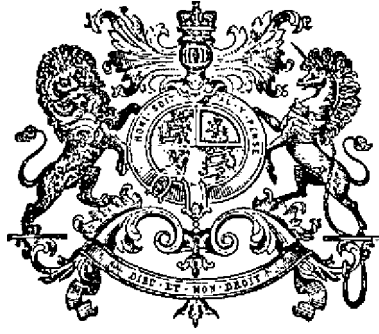


Fig 4



This is the Sheet of Drawings marked D referred to in the annexed
 Letters of Registration, granted to Norman Selfe, this sixteenth
 day of January, A. D. 1884. *Augustus Loftus.*

(Sig: 245)



A.D. 1884, 22nd January. No. 1368.

THE AUSTRALIAN COMBINATION RAILWAY AND TRAM TRUCK, FOR GOODS,
CATTLE, OR SHEEP.

LETTERS OF REGISTRATION to Henry Hudson, William Hudson, Robert Hudson, and Ambrose Thornley, for "The Australian Combination Railway and Tram Truck, for goods, cattle, or sheep."

[Registered on the 22nd day of January, 1884, in pursuance of the Act 16 Vic. No. 24.]

BY HIS EXCELLENCY THE RIGHT HONORABLE SIR AUGUSTUS WILLIAM FREDERICK SPENCER LOFTUS (commonly called LORD AUGUSTUS LOFTUS), Knight Grand Cross of the Most Honorable Order of the Bath, a Member of Her Majesty's Most Honorable Privy Council, Governor and Commander-in-Chief of the Colony of New South Wales and its Dependencies.

TO ALL TO WHOM THESE PRESENTS SHALL COME, greeting :

WHEREAS HENRY HUDSON, WILLIAM HUDSON, ROBERT HUDSON, and AMBROSE THORNLEY, all of the city of Sydney, have by their Petition humbly represented to me that they are the assignees of George Trotter Evans, who is the author or designer of a certain invention or improvement in manufactures, that is to say, of an invention entitled "The Australian Combination Railway and Tram Truck, for goods, cattle, or sheep," which is more particularly described in the specification, marked A, and the two sheets of drawings, marked B and C respectively, which are herunto annexed; and that they, the said Petitioners, have deposited with the Honorable the Treasurer of the said Colony of New South Wales the sum of Twenty Pounds sterling, for defraying the expense of granting these Letters of Registration, as required by the Act of Council, sixteenth Victoria, number twenty-four; and have humbly prayed that I would be pleased to grant Letters of Registration, whereby the exclusive enjoyment and advantage of the said invention or improvement might be secured to them for a period of fourteen years: And I, being willing to give encouragement to all inventions and improvements in the arts or manufactures which may be for the public good, and having received a report favourable to the prayer of the said Petition, from competent persons appointed by me to examine and consider the matters stated therein and to report thereon for my information, am pleased, with the advice of the Executive Council, and in exercise of the power and authority given to me by the said Act of Council, to grant, and do by these Letters of Registration grant unto the said Henry Hudson, William Hudson, Robert Hudson, and Ambrose Thornley, their executors, administrators, and assigns, the exclusive enjoyment and advantage of the said invention or improvement, for and during the term of fourteen years from the date hereof; to have, hold, and exercise unto the said Henry Hudson, William Hudson, Robert Hudson, and Ambrose Thornley, their executors, administrators, and assigns, the exclusive enjoyment and advantage thereof, for and during and unto the full end and term of fourteen years from the date of these presents next and immediately ensuing, and fully to be complete and ended: Provided always, that if the said Henry Hudson, William Hudson, Robert Hudson, and Ambrose Thornley shall not, within three days after the granting of these Letters of Registration, register the same in the proper office in the Supreme Court, at Sydney, in the said Colony of New South Wales, then these Letters of Registration, and all advantages whatsoever hereby granted, shall cease and become void.

In witness whereof, I have herunto set my sign manual, and have caused the present Letters of Registration to be sealed with the seal of the said Colony of New South Wales, at Government House, Sydney, in New South Wales, this twenty-second day of January, in the year of our Lord one thousand eight hundred and eighty-four.

[L.S.]

AUGUSTUS LOFTUS.

The Australian Combination Railway and Tram Truck, for goods, cattle, or sheep.

A.

TO ALL TO WHOM THESE PRESENTS SHALL COME: We, HENRY HUDSON, WILLIAM HUDSON, and ROBERT HUDSON, of Sydney, being the firm of Hudson Brothers (Limited), railway carriage and truck manufacturers, and AMBROSE THORNLEY, also of Sydney, architect, assignees of George Trotter Evans, also of Sydney, gentleman, send greeting:

WHEREAS we are desirous of obtaining Letters of Registration for securing unto us Her Majesty's special license that we, our executors, administrators, and assigns, and such others as we or they shall at any time agree with, and no other, shall and lawfully may from time to time and at all times during the term of fourteen years, to be computed from the day on which this instrument shall be left at the office of the Minister for Justice, Sydney, make, use, exercise, and vend, within the Colony of New South Wales, an invention of a combined truck, entitled "The Australian Combination Railway and Tram Truck, for goods, cattle, or sheep," as more particularly described in the following specification and accompanying tracings.

SPECIFICATION.

THIS invention has been designed for the carriage of goods, cattle, or sheep, as may be required, with especial facilities for the safety and comfort of whatever description of article may be sent by it. When cattle are required to be trucked, the floors of the upper deck or division are lowered, and form convenient lower sides for the entire carriage, so as to prevent the cattle thrusting their horns through the iron bars, or being terrified by external objects. When sheep are trucked, the upper deck or floor is raised into position—supported—and the sheep having been passed in through the upper and lower doors, from a higher and lower platform, divided by bars into several compartments.

When goods are forwarded, the upper deck or floor is lowered against the sides, as when cattle are forwarded; and the goods having been carried in through the doors and packed, the doors are locked and sealed, and the tarpaulins contained under the upper roof or ridge rolled down over the sides and secured so as to exclude rain or sparks.

The floor is designed so as to prevent cattle from slipping and falling down, which is the principal cause of so many deaths at present on journeys. It also affords peculiar facilities for cleaning after use. When used as a sheep truck, provision is made, as already stated, for dividing each floor or deck into three or more compartments, thus guarding against the whole weight of the sheep in each floor of the truck being forced against the few at the ends or sides, when the train is jerked or the sheep become frightened.

As a goods truck the peculiar advantages are already above stated.

That the invention and its advantages may be more easily understood, the following explanation of the letters on the accompanying plans is given.

A, on plan F, represents the cleats as arranged on the floor of cattle and sheep trucks. They are six inches apart one way and three the other, and are raised three-eighths of an inch above the floor, sufficient to give a firm footing to the stock, and at the same time to prevent the possibility of injury to the feet so frequent with the present high battens on the floors of cattle and sheep trucks.

The floors are slightly raised in the centre, and the cleats so arranged as not to allow any water to lodge, and they at the same time afford better facilities for cleansing after use.

D, on plan A, represents the end view of the centre support to upper floor or deck. This support extends the full length of the truck, and is so arranged as to allow of its being raised to the roof by means of two upright screws E E on plan A. The screws are controlled by bevelled gear wheels at the top. The upper wheels F F, on plan A, are both fixed on one shaft, and are controlled by a handle at the end and outside of the truck marked H on plan B.

C B, on plan A, represents cross-section of the upper or portable floor of the sheep truck when in position. This floor is divided longitudinally in the centre, and hinged at both sides. The floor is again divided in cross-sections twice, and when not required as a top floor or deck for sheep truck is lowered to the sides as shown, J K on plan D. For cattle and goods trucks L L, plan A, represents a means by which the top deck or floor is raised and held up while the longitudinal support is being lowered into position. Plan D represents a transverse section of cattle and goods trucks with all internal gear removed.

M M, plan A, represent the two wooden rollers extending the full length of the trucks on which the tarpaulins are rolled when not in use. These rollers are outside, controlled by two hand-wheels on the end of the truck N N, plan E. It is intended that the position of these rollers shall be at the side of the truck and immediately under the eaves of the roof.

Having now described the invention, the advantages may be stated briefly to be:—

1. The convenience of having at hand a truck capable of adaptation, at an instant's notice, to any one of three required uses.
2. The economic saving in time and haulage in not having, as now, to forward special trucks for special purposes, while other trucks incapable of adaptation are remaining unused at hand.
3. The greater amount of traffic power springing from such ready adaptation of means easily made available.

CLAIMS.

First—The combination, substantially as described.

Second—The movable upper deck for sheep, and its utilization as sides for cattle or goods trucks, substantially as described.

Third—The apparatus for raising and lowering such upper deck or floor, substantially as described.

Fourth—The apparatus for the always at hand and instantly applicable protecting tarpaulins.

HENRY HUDSON.
WILLIAM HUDSON.
ROBERT HUDSON.
AMBROSE THORNLEY.

Assignees of GEORGE TROTTER EVANS
(By HENRY HALLORAN, Patent Agent).

2, Wentworth Court,
Sydney, 8 November, 1883.

This is the specification marked A referred to in the annexed Letters of Registration granted to Henry Hudson, William Hudson, Robert Hudson, and Ambrose Thornley, this twenty-second day of January, A.D. 1884.

AUGUSTUS LOFTUS.

REPORT.

The Australian Combination Railway and Tram Truck, for goods, cattle, or sheep.

REPORT.

Sir,

Sydney, 29 November, 1883.

We do ourselves the honor to report, in reply to your blank cover of the 13th instant, No. 83-13,548, that we are of opinion that the prayer of Messrs. Henry Hudson, William Hudson, Robert Hudson, and Ambrose Thornley (as assignees of George T. Evans), for the registration of an invention entitled "The Australian Combination Railway and Tram Truck, for goods, cattle, or sheep," may be granted, in terms of their drawings and specification.

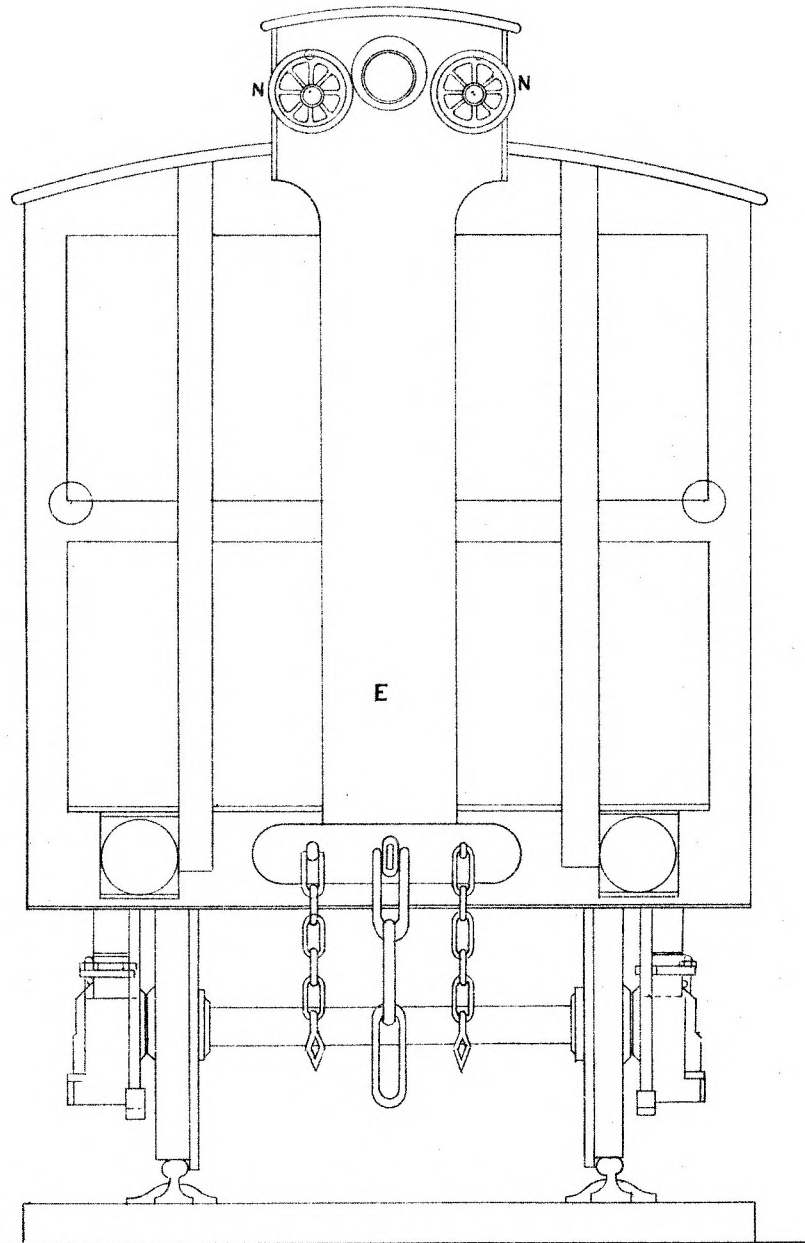
We have, &c.,
JOHN WHITTON.
E. O. MORIARTY.

The Under Secretary of Justice.

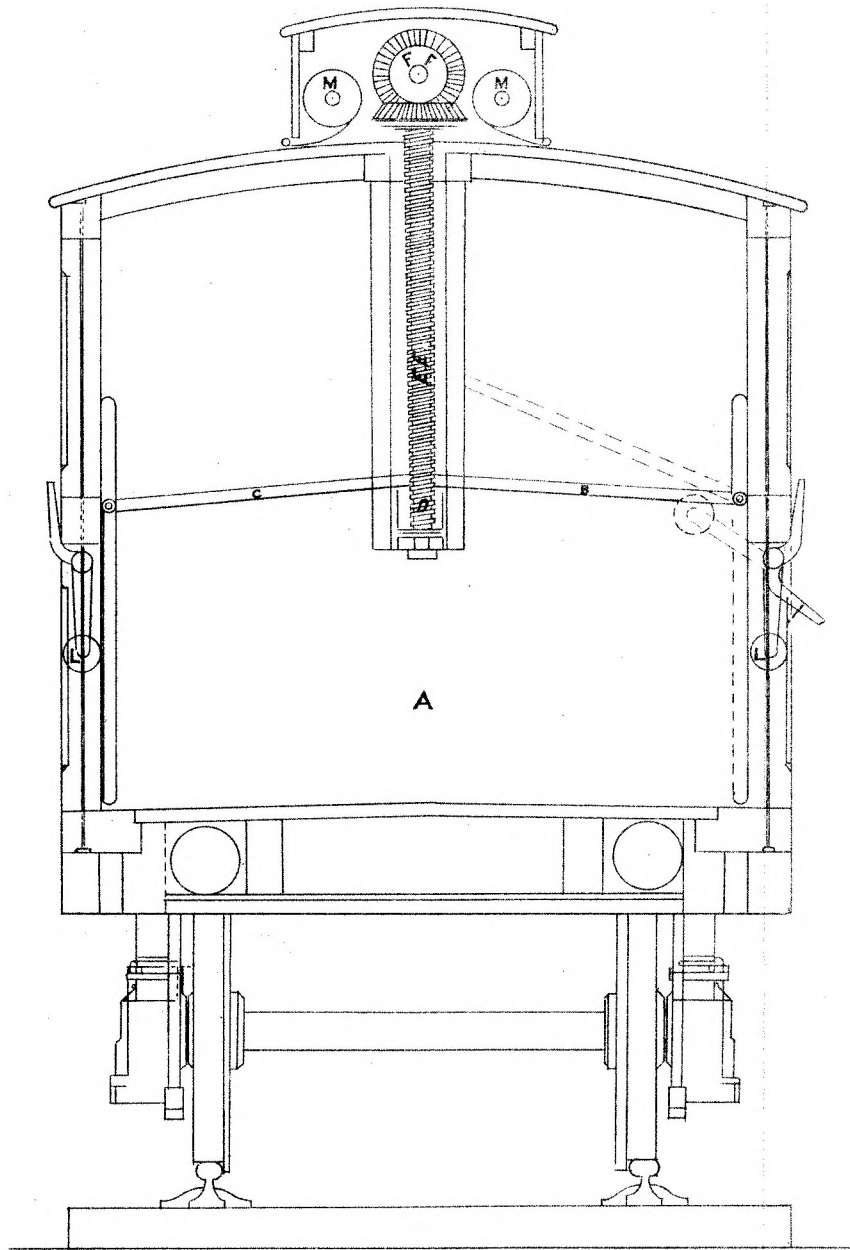
[Drawings—two sheets.]

SHEET N^o 2

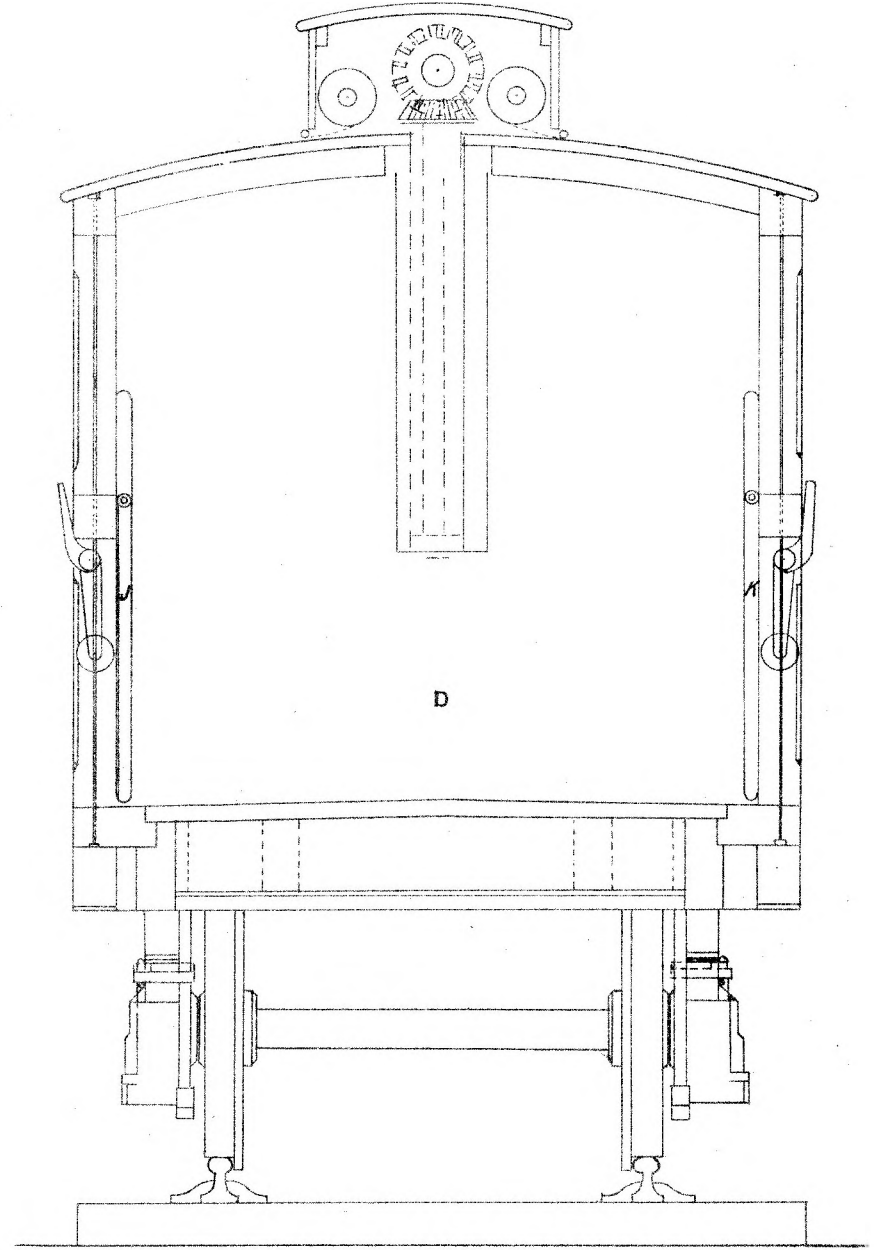
"C"



END ELEVATION



SECTION through A.B. showing a complete Sheep Waggon or Truck



SECTION showing a complete Cattle Waggon or Truck.

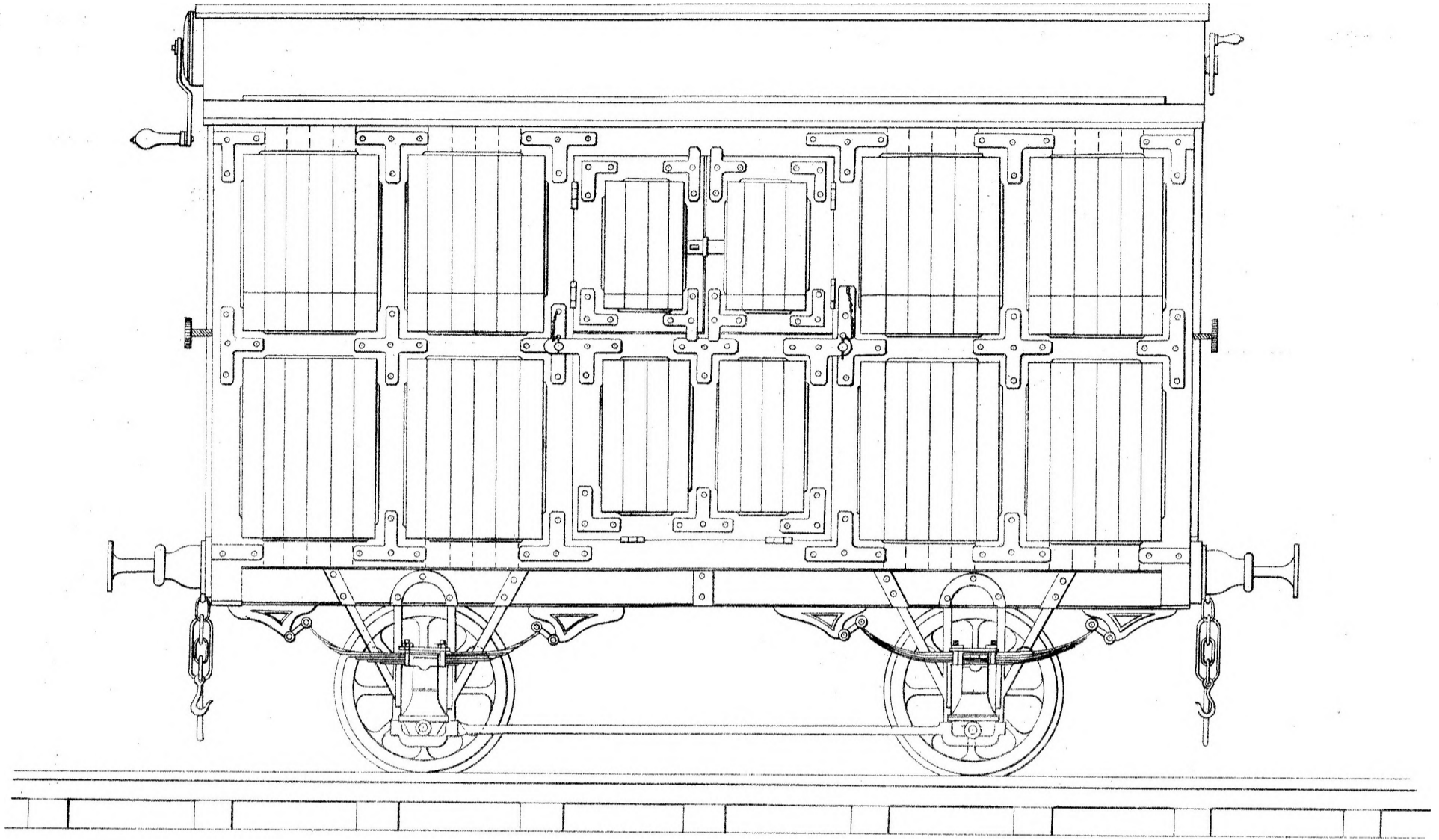


This is the sheet of Drawings marked "C" referred to in the annexed Letters of Registration granted to Henry Hudson, William Hudson, Robert Hudson and Ambrose Thornley, this twenty second day of January A.D. 1884.

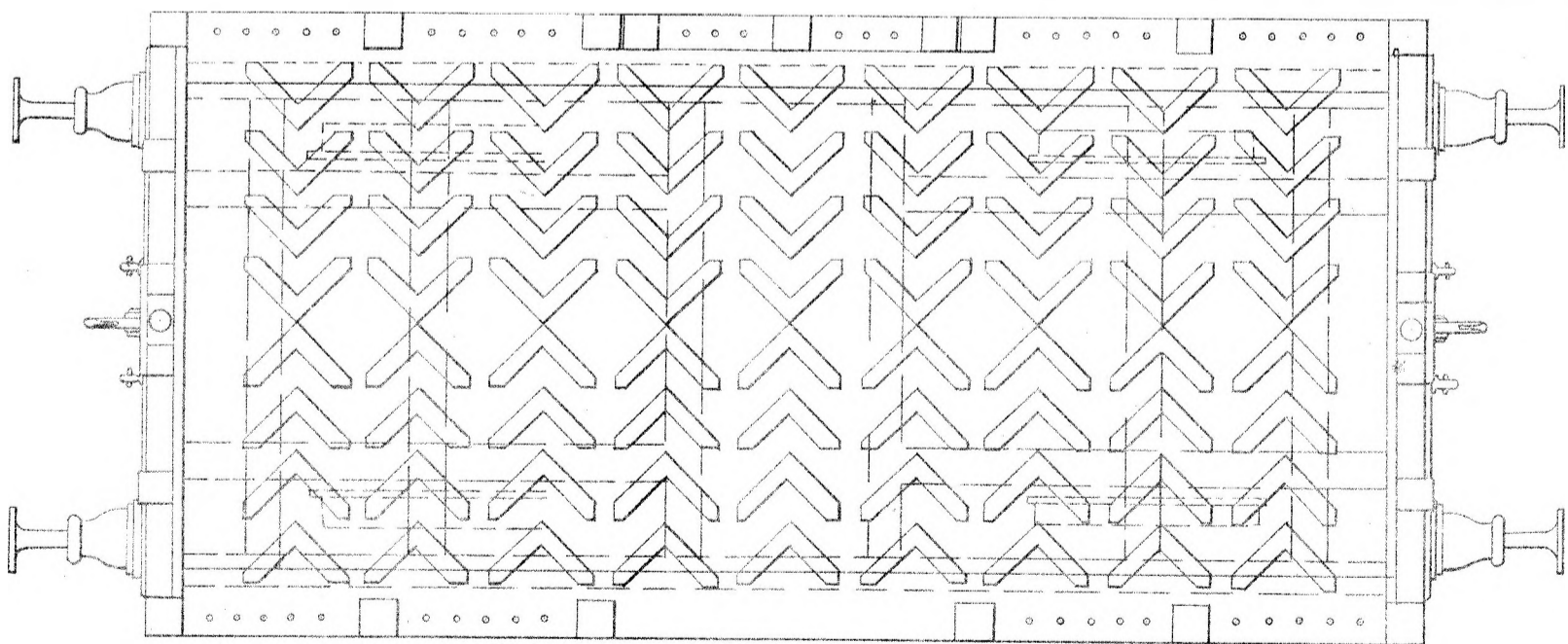
Augustus Loftus

(Sig 245 -)

PLAN OF A COMBINATION
KNOWN AS THE
AUSTRALIAN



Side Elevation . B.



Plan . F.

*This is the Sheet of Drawings marked B, referred to in the
annexed Letters of Registration granted to Henry Hudson,
William Hudson, Robert Hudson, and Ambrose Thornley
this twenty second day of January A.D. 1884.*

Augustus Loftus.



A.D. 1884, 22nd January. No. 1369.

IMPROVEMENTS IN CIRCULAR SAWS.

LETTERS OF REGISTRATION to James Brookhouse Preston and James Shepherd, for Improvements in Circular Saws.

[Registered on the 23rd day of January, 1884, in pursuance of the Act 16 Vic. No. 24.]

BY HIS EXCELLENCY THE RIGHT HONORABLE SIR AUGUSTUS WILLIAM FREDERICK SPENCER LOFTUS (commonly called LORD AUGUSTUS LOFTUS), Knight Grand Cross of the Most Honorable Order of the Bath, a Member of Her Majesty's Most Honorable Privy Council, Governor and Commander-in-Chief of the Colony of New South Wales and its Dependencies.

TO ALL TO WHOM THESE PRESENTS SHALL COME, greeting:

WHEREAS JAMES BROOKHOUSE PRESTON, engineer, and JAMES SHEPHERD, builder, both of Sydney, in the Colony of New South Wales, have by their Petition humbly represented to me that they are the authors or designers of a certain invention or improvement in manufactures, that is to say, of an invention entitled "Improvements in Circular Saws," which is more particularly described in the specification and the sheet of drawings which are hereunto annexed; and that they, the said Petitioners, have deposited with the Honorable the Treasurer of the said Colony of New South Wales the sum of Twenty Pounds sterling, for defraying the expense of granting these Letters of Registration, as required by the Act of Council, sixteenth Victoria, number twenty-four; and have humbly prayed that I would be pleased to grant Letters of Registration, whereby the exclusive enjoyment and advantage of the said invention or improvement might be secured to them for a period of fourteen years: And I, being willing to give encouragement to all inventions and improvements in the arts or manufactures which may be for the public good, and having received a report favourable to the prayer of the said Petition, from competent persons appointed by me to examine and consider the matters stated therein and to report thereon for my information, am pleased, with the advice of the Executive Council, and in exercise of the power and authority given to me by the said Act of Council, to grant, and do by these Letters of Registration grant unto the said James Brookhouse Preston and James Shepherd, their executors, administrators, and assigns, the exclusive enjoyment and advantage of the said invention or improvement, for and during the term of fourteen years from the date hereof; to have, hold, and exercise unto the said James Brookhouse Preston and James Shepherd, their executors, administrators, and assigns, the exclusive enjoyment and advantage thereof, for and during and unto the full end and term of fourteen years from the date of these presents next and immediately ensuing, and fully to be complete and ended: Provided always, that if the said James Brookhouse Preston and James Shepherd shall not, within three days after the granting of these Letters of Registration, register the same in the proper office in the Supreme Court, at Sydney, in the said Colony of New South Wales, then these Letters of Registration, and all advantages whatsoever hereby granted, shall cease and become void.

In witness whereof, I have hereunto set my sign manual, and have caused the present Letters of Registration to be sealed with the seal of the said Colony of New South Wales, at Government House, Sydney, in New South Wales, this twenty-second day of January, in the year of our Lord one thousand eight hundred and eighty-four.

[L.s.]

AUGUSTUS LOFTUS.

Improvements in Circular Saws.

SPECIFICATION of JAMES BROOKHOUSE PRESTON, engineer, and JAMES SHEPHERD, builder, both of Sydney, in the Colony of New South Wales, for an invention entitled "Improvements in Circular Saws."

Our invention relates to that class of circular saws which are "dished," or have a concavity in one side, and, of course, a convexity on the other, and which are known as "dished saws." It consists in certain improvements by which such dished saws are made specially suitable for sawing timber into felloes for wheels, and into other arc-bounded shapes.

Our improvements in circular saws consist, first and essentially, in the combination and arrangement with a dished saw of a bench set at in a plane at or approximately at right angles to the chord of any certain arc of said saw, so that the side of the sawn timber (whatever its thickness might be) will be square, or almost square, with its face; secondly, in a partially-revolving table, having its motion around the centre of that imaginary sphere of which said dished saw is a part; and, thirdly, in the combination and arrangement of mechanical parts, forming such angularly-set bench, and such partially-revolving table.

But in order that our invention may be clearly understood, we will now describe the same with reference to the drawings, in which figure 1 is a side elevation, figure 2 an end view, and figure 3 a plan of a saw and bench, constructed according to our invention. A is the revolving table, and B the bench; C is the saw, and D the main frame. A¹ is the frame of table A, and A² its pivot; A³ circular slot therein; A⁴ adjustable stops; and A⁵ handles; B¹B¹ are semi-circular guides on which frame A¹ rides; B²B² are legs, having adjustable connecting bar B³; B⁴B⁴ are the pivots of the bench to main frame D; B⁵ and B⁶ are stops for frame A¹. C¹ is saw-spindle, C²C² bearings, and C³ driving pulley.

The radius of the revolving table (that is, the distance from the face of the saw to the pivot of the table), and of the imaginary sphere of which the saw is a part, must be equal, and the saw will cut out felloes or arcs of the same radius. In operation, it is first necessary to set the table in a plane, at right angles to that chord of the arc of the saw C, in this case immediately above the table A, as is equal to the thickness or depth of the timber to be sawn, as near as may be at right angles to the bench; this is effected by increasing or diminishing the spread of the legs B² by means of connecting bar B³, which action lowers or raises, as the case may be, the bench B on pivots B⁴; stops A⁴ are also adjusted, so that the felloe or arc will be cut of the required width when the convex side is pushed to said stops. The saw being in motion the timber is placed on table A, which is then partially revolved by handle A⁵ past the saw C until frame A¹ comes against stop B⁵, the timber being sawn out to the required circle. The table A on frame A¹ is then drawn back to stop B⁶, the cut timber pushed to stops A⁴, and a second cut taken, which completes a felloe.

Having thus particularly described and ascertained the nature of our invention, and the manner in which the same is to be performed, we would have it understood that we do not confine ourselves to the precise methods in which it is to be carried into effect; for instance, we might fix the bench horizontally and set the saw-spindle at an angle to it, but what we believe to be new, and therefore claim as our improvements in circular saws, is—

First—The combination and arrangement with a "dished saw" of a bench set approximately at a right angle to a chord of any certain arc of said saw.

Second—The combination with said angularly-set saw and bench of a partially-revolving table having a motion around the centre of that imaginary sphere of which said saw is a part.

Third—The combination and arrangement of table A, having pivot A², slot A³, and frame A¹, with bench B, guides B¹, and legs B², substantially as herein described and explained, and as illustrated in the drawings.

In witness whereof, we, the said James Brookhouse Preston and James Shepherd, have hereto set our hands and seals, this eighth day of November, one thousand eight hundred and eighty-three.

Witness—

FRED. WALSH,
Manager, Edwd. Waters' Patent Office, Sydney.

JAMES B. PRESTON.
JAMES SHEPHERD.

This is the specification referred to in the annexed Letters of Registration granted to James Brookhouse Preston and James Shepherd, this 22nd day of January, A.D. 1884.

AUGUSTUS LOFTUS.

REPORT.

Sir,

In accordance with your B.C. minute of the 13th instant, on the application for the issue of Letters of Registration of an invention by Messrs. Preston and Shepherd, entitled "Improvements in Circular Saws," we have to report that we see no objection to the granting of the protection applied for.

We have, &c.,

JAMES BARNET.
WILLIAM C. BENNETT.

The Under Secretary of Justice.

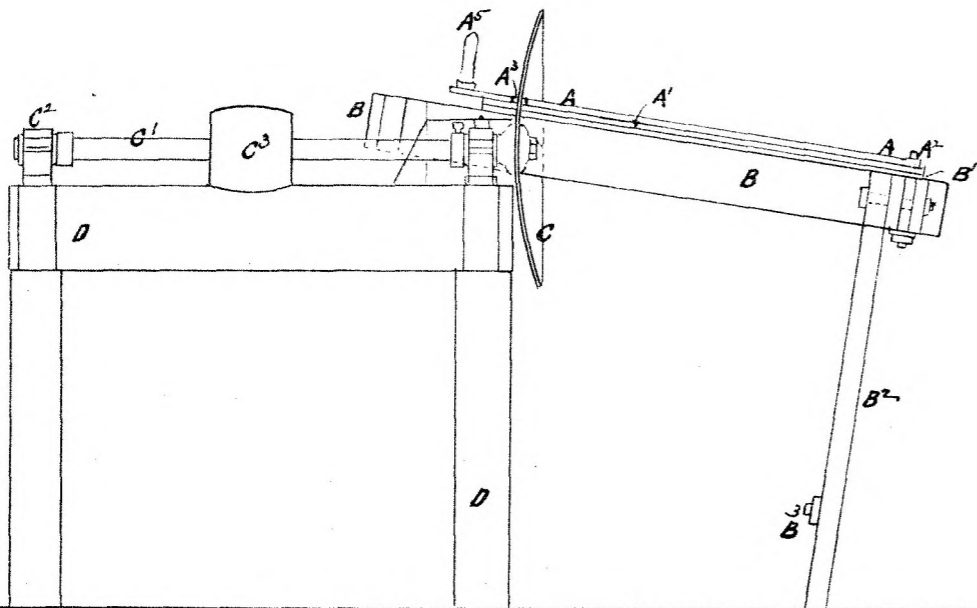


Fig: 1.

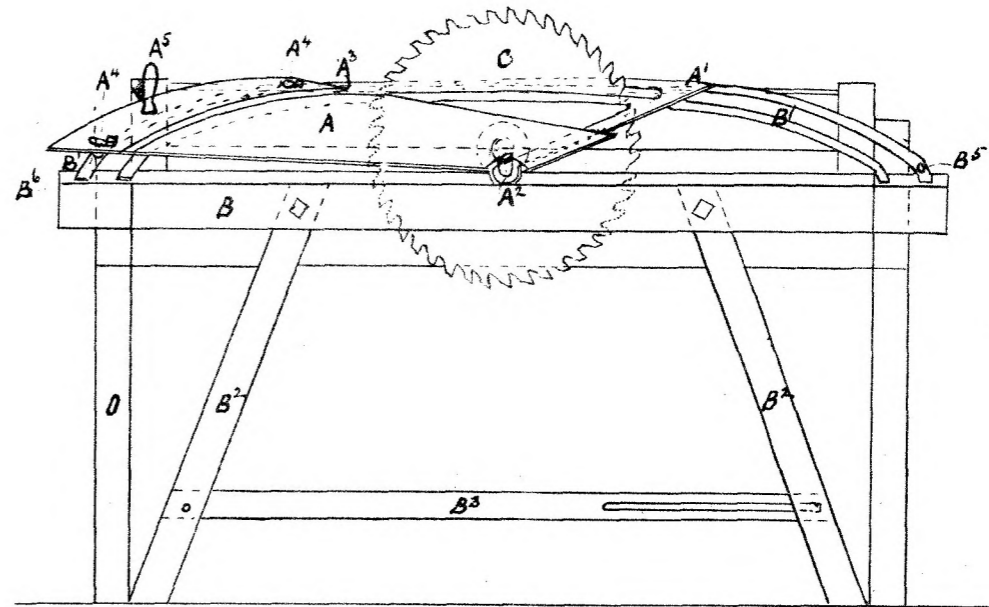


Fig: 2.

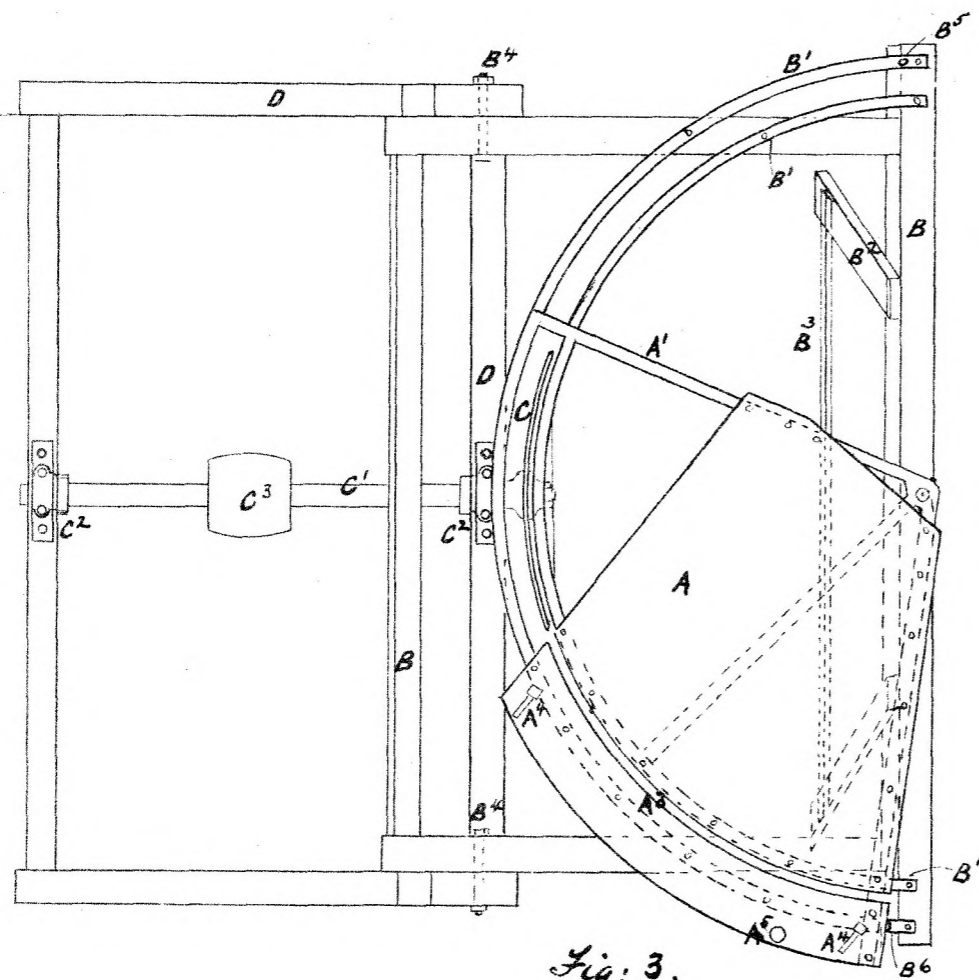


Fig: 3.

Mess^{rs} Preston & Shepherd's

PATENT.

This is the Sheet of Drawings referred to in the annexed Letters of Registration, granted to James Brookhouse Preston and James Shepherd, this twenty second day of January, A.D., 1884.

Augustus Loftus.



A.D. 1884, 22nd January. No. 1370.

IMPROVEMENTS IN OR CONNECTED WITH SECONDARY BATTERIES.

LETTERS OF REGISTRATION to the Consolidated Electric Company (Limited),
for Improvements in or connected with Secondary Batteries.

[Registered on the 23rd day of January, 1884, in pursuance of the Act 16 Vic. No 24.]

BY HIS EXCELLENCY THE RIGHT HONORABLE SIR AUGUSTUS WILLIAM FREDERICK SPENCER LOFTUS (commonly called LORD AUGUSTUS LOFTUS), Knight Grand Cross of the Most Honorable Order of the Bath, a Member of Her Majesty's Most Honorable Privy Council, Governor and Commander-in-Chief of the Colony of New South Wales and its Dependencies.

TO ALL TO WHOM THESE PRESENTS SHALL COME, greeting :

WHEREAS THE CONSOLIDATED ELECTRIC COMPANY (Limited), of 110, Cannon-street, in the city of London, in England, hath by its Petition humbly represented to me that it is the Assignee (so far as the Colony of New South Wales is concerned) of Joseph Samuel Beeman, William Taylor, and Frank King, who are the authors or designers of a certain invention or improvement in manufactures, that is to say, of an invention entitled "Improvements in or connected with Secondary Batteries," which is more particularly described in the specification, marked "A," and the three sheets of drawings, marked "B," "C," and "D," respectively, which are hereunto annexed; and that the said Petitioner hath deposited with the Honorable the Treasurer of the said Colony of New South Wales the sum of Twenty Pounds sterling, for defraying the expense of granting these Letters of Registration, as required by the Act of Council, sixteenth Victoria, number twenty-four; and hath humbly prayed that I would be pleased to grant Letters of Registration, whereby the exclusive enjoyment and advantage of the said invention or improvement might be secured to it for a period of fourteen years: And I, being willing to give encouragement to all inventions and improvements in the arts or manufactures which may be for the public good, and having received a report favourable to the prayer of the said Petition, from competent persons appointed by me to examine and consider the matters stated therein and to report thereon for my information, am pleased, with the advice of the Executive Council, and in exercise of the power and authority given to me by the said Act of Council, to grant, and do by these Letters of Registration grant unto the said Consolidated Electric Company, its successors, and assigns, the exclusive enjoyment and advantage of the said inventions or improvement, for and during the term of fourteen years from the date hereof; to have, hold, and exercise unto the said Consolidated Electric Company, its successors, and assigns, the exclusive enjoyment and advantage thereof, for and during and until the full end and term of fourteen years from the date of these presents next and immediately ensuing, and fully to be complete and ended: Provided always, that if the said Consolidated Electric Company shall not, within three days after the granting of these Letters of Registration, register the same in the proper office in the Supreme Court, at Sydney, in the said Colony of New South Wales, then these Letters of Registration, and all advantages whatsoever hereby granted, shall cease and become void.

In witness whereof, I have hereunto set my sign manual, and have caused the present Letters of Registration to be sealed with the seal of the said Colony of New South Wales, at Government House, Sydney, in New South Wales, this twenty-second day of January, in the year of our Lord one thousand eight hundred and eighty-four.

[L.S.]

AUGUSTUS LOFTUS.

Improvements in or connected with Secondary Batteries.

A.

SPECIFICATION of the CONSOLIDATED ELECTRIC COMPANY (Limited), of 110, Cannon-street, in the city of London, in England, the assignee of the author or designer of an invention entitled "Improvements in or connected with Secondary Batteries."

THE said invention relates to new forms of plates or electrodes for secondary batteries or accumulators, which are formed by coiling tapes or strips produced in a new form, and by a cheaper, quicker, and better mode of manufacturing than has hitherto been adopted. In carrying out the said invention, we form the improved plates by coiling special forms of tapes or bands of lead, which are cut out of or from the solid, by or in a lathe or other cutting machine, such as hereinafter described, in such manner that the surface of the band that does not come in contact with the cutting tool shall have given to it a roughened or cellulated surface, raised by the angle at which the cutting tool is worked. The plate constructed by coiling tapes cut in the form above mentioned is rendered more efficient for the purpose sought to be attained by increasing in, and by one operation, the extent of surface acted on by the electrolyte. In some cases the tape may be cut thinner in places by adjusting the cutting tool as required, or a thin tape or tapes may be interposed between thicker ones in making up the plate. The plate is formed by receiving the lead tape direct from the cutting tool, and winding it (and, when needed, with interposed thin tapes) round a mandrel provided with cheeks, which may have either flat or corrugated surfaces, thereby producing a plate or disc with flat or uneven surfaces; the edges of the coiled tapes are fastened at suitable parts of the plate so produced, by being stamped or pressed together, so as to give stability or rigidity to the plate.

The kind of cutting machine which we find suitable for cutting the tapes or strips of lead in the required form is constructed as follows:—When the tape is to be uniform in thickness we use an ordinary surfacing lathe, the motion of the slide rest thereof being adjusted to the thickness required; but when a tape of varying thickness is required we make the feed wheel on the slide rest eccentric, and give the shaft carrying the actuating worm a rocking as well as rotating motion, and this is readily performed by gearing the shaft carrying the worm into the back gearing of an ordinary lathe head, such shaft being provided at the lathe head end with a ball and socket, or other suitable bearing, the end of the shaft working in a sliding journal.

The said invention also relates to the formation of plates for electrodes, made of insulating tape-like materials in combination with suitable metal ribbons; also of insulating tapes covered with metal, in combination with an insulating ribbon, tape, or strip, alone or so used as to form a carrier or vehicle for salts of lead, or lead in a finely-divided condition, such insulating carrier being sandwiched, so to speak, between the metallised ribbons or their substitutes. The insulating carrier and metal ribbons, or either, may be made in any convenient manner, and may be corrugated longitudinally and transversely, or either way, and of any convenient shape. The said insulating strips are coated with the powdered and inert material on one side, and with salts of lead on the other. Part of the said invention also refers to plates formed as above, and used in combination with an improved cell made of wood soaked in or coated with paraffine, lined with a cell of paper also soaked in or coated with paraffine, and having a layer of paraffine interposed between the wood and paper cell. Sometimes we use an extra partial casing of sheet iron outside of the wooden casing, with an interposed layer of paraffine wax, and we sometime creosote the wood casing before soaking it in the paraffine wax. Part of the invention further relates, in combination with the above improvements, or some of them, to a mode of connecting the different sets of plate together, so that any one plate may be easily removed; and to the formation of a hook attachment for connecting the cells together, together with an improved valve for ventilating the cells; also, in combination with the improved plates, part of the said invention relates to an improved mode of applying studs, rods, tubes, or their equivalents (either alone or in combination with rings), to support and keep in position, together and apart, the plates, the said studs, rods, tubes, and rings being made of any convenient non-conducting material, such as glass, porcelain, vulcanite, or of metal or wood covered with non-conducting material. The said invention also refers (in combination with the improved cell) to the use of an insulated tray or stand for supporting the said cell, and for holding oil to prevent return current by earth. The accompanying drawings will serve further to show how the said invention may be performed, but we do not limit ourselves to the exact modes therein shown, as it will be evident that they may be varied without departing from the nature of the invention. In all the figures, like letters indicate like or corresponding parts.

Figures 1, 2, 3, 4, 5 and 6 show elevations of various forms of combined insulating strips and metal ribbons, the dotted lines representing the insulated strips; the other lines represent metal or metallised strips. These strips may be in themselves made up in corrugated or other suitable forms; said strips and ribbons are formed into a plate or plates by rolling them on mandrels, having adjustable and plain-faced or curved-shaped cheeks, the corners or other parts being secured by stamping or otherwise, to secure stability and rigidity. Fig. 7 is a longitudinal section; and fig. 8 is a half elevation and half cross-section of a cell showing the mode of hanging the plates B, each by a hanger or yoke piece A, with shoulders, serving to keep the plates from the sides, top, and bottom of the cell. The pieces A are preferably made of lead, covered with suitable varnish, to prevent the electrolyte from acting on them. We solder on to the end of each lead yoke A (alternately at opposite sides of adjacent plates) a tip or piece of brass or copper a^1 , and gild the same, and also the connecting rods and hooks H, to prevent oxidation. C are distance studs, incorporated with the plates B, and serving to keep said plates off their neighbouring plates. These studs may be of the form shown in figures 7, 8, 9, 10, 11, 12, and 13, or rings D may be used in combination with rods, as shown in figures 14, 15, 11, and 13.

The cell E is made of wood, soaked in liquid paraffine wax, or coated with paraffine or paraffine wax; the wood may be previously creosoted; a paper cell, F (serving as a lining), is soaked in liquid paraffine wax, or coated with paraffine or paraffine wax, and then forced into the cell E, which previously is also coated on its interior with liquid paraffine wax, and by this means a layer of wax is interposed between E and F. G is a metal envelope, or partial outer casing, which is also lined internally with paraffine. Figures 7 and 8 show the mode of connecting the several terminals of the two sets of plates to their respective metal electrical communicator, of which communicators there are two, one common to the plates of each kind, and so arranged that any one plate can be removed without materially interfering with the action of the battery

The

Improvements in or connected with Secondary Batteries.

The hook *H* is for connecting one cell to its neighbouring cell. *J* is the ventilator, for letting out gases generated in the cell, and also serves for a ready means for inspection of the interior of the cell. It is shown separately in plan in fig. 17.

Figure 16 shows a method of supporting the plates by means of glass rods, or their equivalents, *L*, held in position by cross rods *K* (serving as distance pieces), or, as in figures 14 and 15, with a support, *L*, fastened to the cell, and distance rings *D* in lieu of the cross rods *K*. In figures 7 and 8, *b* is a stand or tray having supports, *b'*, for carrying the cell. The said tray is filled with oil or glycerine, and serves to prevent return currents by earth.

The said invention further relates to the manufacture of a cell, constructed partly on the principle of a storage or secondary battery, as used for storing electricity, and provided with plates proportioned to the amount of current to be stored or used. The whole, or a portion only, of such plates and battery is divided off by an air or gas tight chamber, closed at one end with a fluid joint, and filled at the other end with a telescopic chamber or elastic diaphragm or piston, in such a manner that the gas evolved from the battery by its pressure on the telescopic chamber or equivalent causes the same to rise, and move suitable indicating and contact-breaking apparatus when the pressure rises to any given amount. In some cases the movable chamber or diaphragm is used to actuate a train of wheels with a recording device, or by means of an actuating lever or other equivalent; it is used to diminish or regulate, shunt, or cut off the current from the battery or generator. In some cases, in lieu of the chamber being telescopic, it may be made closed at one end, and closed at the other with a fluid joint, when the gas evolved will cause the liquid of the fluid joint to be forced out from the gas-holder into the cell, and there actuate a float or other equivalent, and effect the same or similar results to those above referred to. The next drawings will serve to illustrate various modes of carrying this part of the said invention into effect; but we would remark, as regards the contact-breaking or current-regulating or indicating apparatus, that the devices shown may be modified considerably without departing from the nature of the invention. In all the figures, like letters refer to like or corresponding parts.

Figures 18, 19, and 20 are respectively a part plan, a longitudinal section, and a transverse section of a storage or secondary battery cell, fitted according to the said invention with what we call gas chamber *B*, holding a plate or plates *A*, which are made proportionately in size to the amount of current electric energy intended to be stored by the battery. The chamber *B* may be of any convenient size or shape, and may extend over and occupy the whole of the cell, as in figures 33 and 34. In the chamber *B* is formed a suitable orifice, fitted with an elastic diaphragm or equivalent *D*, as in figures 19, 23, 24, 27, 28, and 32, or, in lieu of said diaphragm, a telescopic chamber *E*, as in fig. 25, may be used, or a piston *F*, as in fig. 26, or apparatus similar to a Bourdon pressure-gauge tube may be used; said diaphragm, or the equivalent therefor, is acted on by the pressure of the gas evolved from the plate or plates *A* contained in the chamber or cell *B*, or the diaphragm or its equivalent may be made large enough to cover the whole chamber or cell, or both, and is acted on by the battery plates generally, as in figures 33 and 34. On the diaphragm or equivalent being lifted it raises a lever or other device *G*, which rests or is fixed on it, and the said lever or device is made to operate any well-known electrical contact-breaking apparatus, or such breaking apparatus as are shown in figures 18, 20, 21, and 23, where *G* is the lever or equivalent, actuated by the diaphragm *D* or its equivalent in the arrangements. Figures 18, 20, and 21, the said lever *G* is furnished at one end with a rod *H*, dipping in a cup *I*, supplied with mercury or other metallic contact-breaker, said mercury or equivalent being in electrical connection with the electric generator, or any other contact-breaking apparatus.

Figures 29 and 30 show modes of using the diaphragm *D*, or its equivalent, for actuating a style or train of wheels, and recording devices in connection with apparatus, which will stop the balance wheel of a clock mechanism when the diaphragm is in action, as shown in fig. 31.

Figure 21 shows apparatus whereby the orifice *C* may be dispensed with, and in lieu thereof, and of its diaphragm *D*, a float *K* may be used, actuated by the rise and fall of the electrolyte in the cell, said electrolyte being operated upon by the gas in the chamber *B*, the electrolyte being kept at a uniform level by any convenient method, such as by means of a reservoir, as shown.

Figure 22 shows apparatus in which the orifice *C* has inserted in it a bent tube *C'*, partially filled with liquid (preferably mercury), as shown; the gas evolved from the plate or plates *A* passing into the said bent tube impinges on the said liquid, thereby causing it to rise in the bent tube and there actuate a float or equivalent fitted with devices for the purpose of breaking electrical contact. When mercury is used in the tube as the liquid, and the tube is made of glass, a metal wire or wires can be introduced through or into the glass, so as to come into contact with the mercury at any desired point, and thus make or break electrical contact. When the apparatus is used for regulating secondary batteries we proportion the size and position of the plate or plates *A*, by making such plates smaller than the plates or electrodes of the battery proper, according to the amount of current to be stored in the battery. It is found that the plate *A* being made, say, nine-tenths of the storage capacity of any other plate in the battery, gives a desirable result, and that the battery is thereby cut out of the charging circuit some time before the gas would otherwise be evolved from the battery plates, and thus prolonging considerably the life of the plates composing the battery.

We claim as the invention,—

First—The manufacture of our improved plates by coiling strips or tapes of lead, when cut in the required shape, with uneven surfaces, in the manner and for the purposes substantially as above described.

Second—The formation of secondary or storage batteries of ribbons or tapes of insulating material, covered with metal, combined with lead or lead salts, or of ribbons or tapes of metal, in combination with an insulating ribbon or tape, alone or used to form a carrier for lead or lead salts, substantially, as illustrated and described.

Third—The use, in combination with the improved plates, of powdered and inert material for covering the insulating ribbons for batteries, alone, or in combination with lead or lead salts, and the use of such ribbons, when coated with inert material on one side, and lead or lead salts on the other, substantially as described.

Fourth—

Improvements in or connected with Secondary Batteries.

Fourth—In combination with the improved plates, the mode of connecting the plates, the hook attachment connection, the ventilating valve, the distance studs and supporting rods, or their respective equivalents, and the insulated tray stand or support for cell, all substantially as and for the purposes described and illustrated.

Fifth—The combination with a secondary battery or batteries of a gas chamber, and plate or plates, elastic diaphragm, or its equivalent, or a fluid joint, alone or in combination with contact-breaking, or measuring, or recording devices, one or more, substantially as illustrated and described, and for the purposes set forth.

Sixth—The use, in combination with secondary batteries, of a gas chamber, and plate or plates, and float device, such as are hereinbefore described, either alone, or in combination with contact-breaking, measuring, or recording devices, one or more of them, substantially as illustrated and described, and for the purposes set forth.

Seventh—The combinations of parts consisting respectively of a plate or plates, chamber, and and moveable diaphragm, or its equivalent, when used in combination with contact breaking, or measuring, or recording devices (one or more of them), the same being combined with secondary batteries, substantially, as in the various modifications herein described and illustrated in the drawings annexed.

Eighth—In combination with secondary batteries, the use of a gas chamber, closed at the bottom with a liquid joint, so that gas collecting in said chamber may cause the liquid to rise in an opening provided and arranged for the purpose, so as to actuate a contact-breaking, measuring, or recording device, substantially as hereinbefore described.

THE CONSOLIDATED ELECTRIC COMPANY (LIMITED).

(By their Agent, EDWD. WATERS.)

Witness—

W. S. BAYSTON,
Patent Law Clerk, Melbourne.

This is the specification, marked A, referred to in the annexed Letters of Registration, granted to the Consolidated Electric Company (Limited), the 22nd day of January, A.D. 1884.

AUGUSTUS LOFTUS.

REPORT.

Sir,

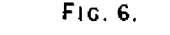
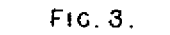
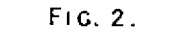
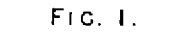
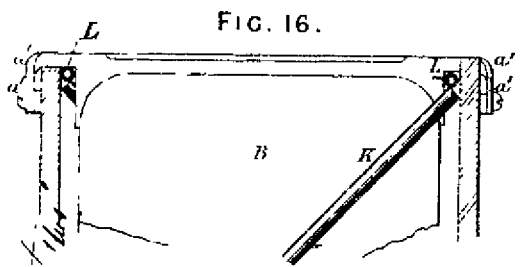
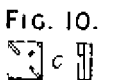
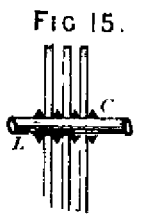
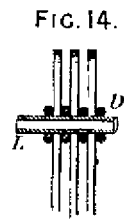
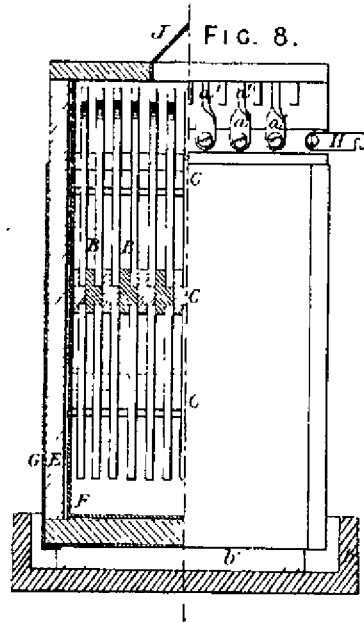
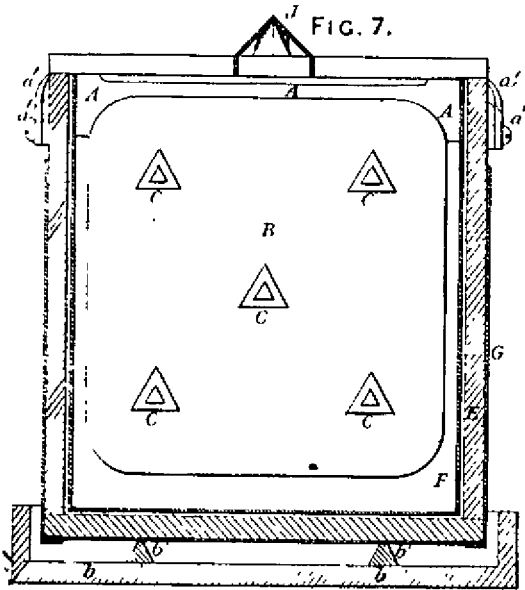
We have examined the specification and drawings accompanying the application for Letters of Registration from the Consolidated Electric Company, 83/10,986, for "Improvements in Secondary Batteries," and consider the petition should be granted.

The Under Secretary of Justice.

Sydney, 7 September, 1883.

We have, &c.,
E. C. CRACKNELL.
H. C. RUSSELL.

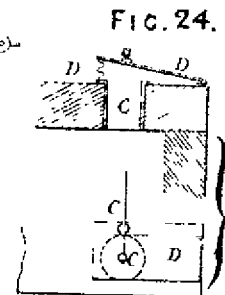
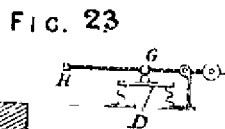
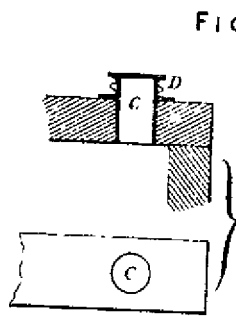
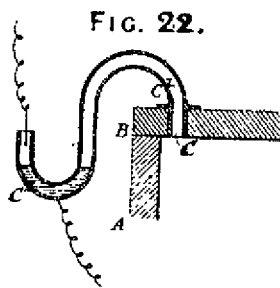
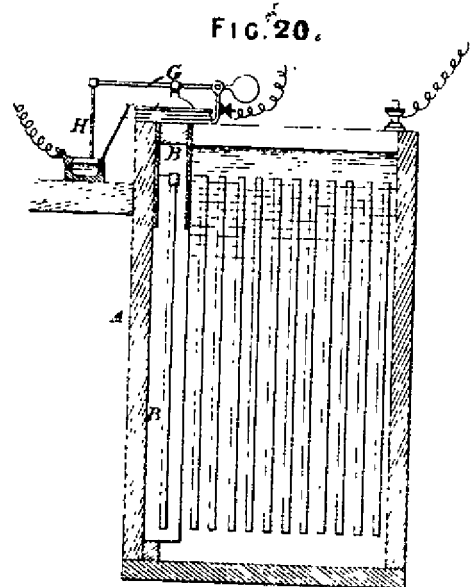
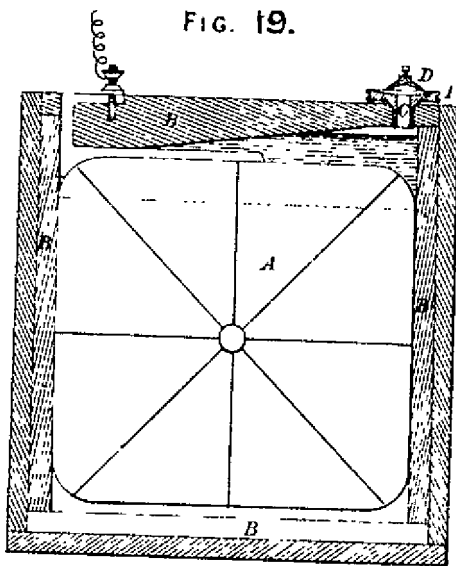
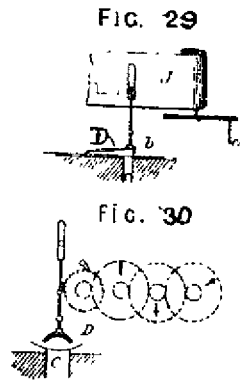
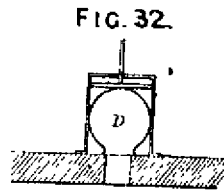
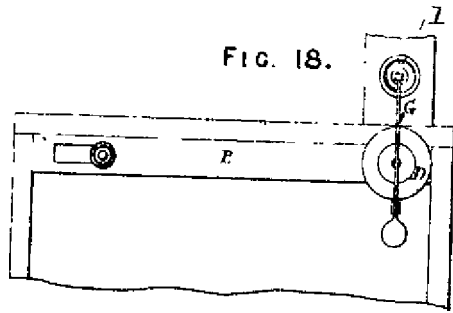
[Drawings—three sheets.]



This is the Sheet of Drawings marked D, referred to in the annexed Letters of Registration, granted to the Consolidated Electric Company (limited) the twenty second day of January, A.D. 1884.

Augustus Loftus.

(Sig: 245-)



This is the Sheet of Drawings marked C referred to in the annexed Letters of Registration, granted to the Consolidated Electric Company (limited) the twenty-second day of January, A.D. 1884.

Augustus Loftus.

(Sig: 245-)

FIG. 21.

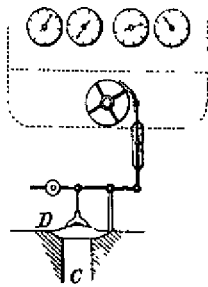


FIG. 33

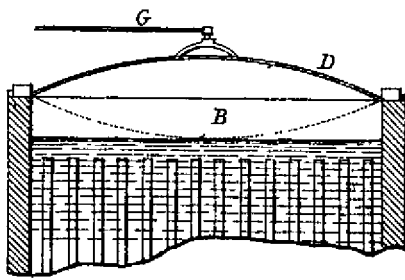


FIG. 34.

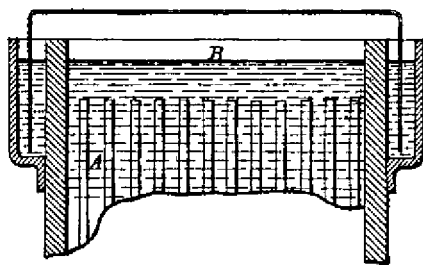


FIG. 21.

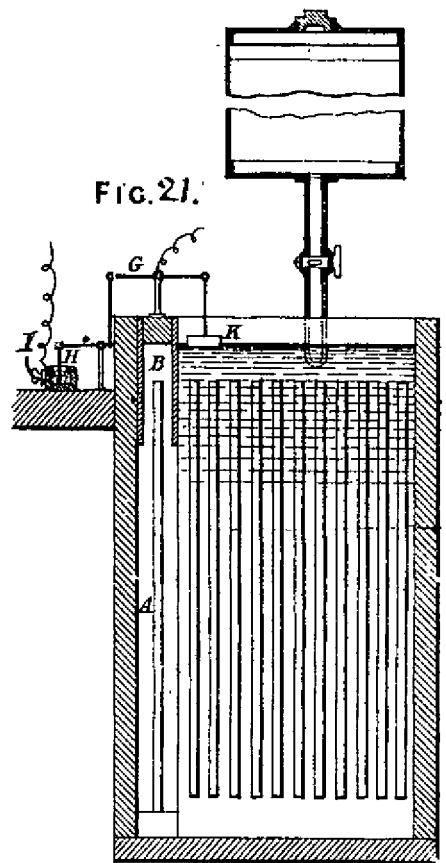


FIG. 25

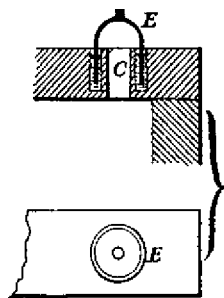


FIG. 26

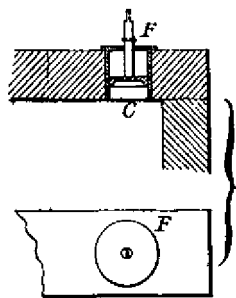


FIG. 27.

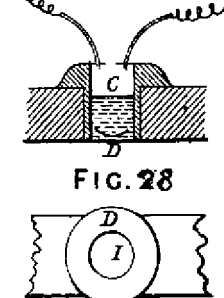


FIG. 28

This is the Sheet of Drawings marked D, referred to in the annexed Letters of Registration, granted to the Consolidated Electric Company (limited) the twenty second day of January, A.D., 1884.

Augustus Loftus.

(Sig: 245-)



A.D. 1884, 22nd January. No. 1371.

IMPROVEMENTS IN ELECTRIC-CURRENT MEASURING AND GOVERNING
APPARATUS.

LETTERS OF REGISTRATION to The Consolidated Electric Company (Limited),
for Improvements in Electric-current Measuring and Governing Apparatus.

[Registered on the 23rd day of January, 1884, in pursuance of the Act 16 Vic. No. 24.]

BY HIS EXCELLENCY THE RIGHT HONORABLE SIR AUGUSTUS WILLIAM FREDERICK SPENCER LOFTUS
(commonly called LORD AUGUSTUS LOFTUS), Knight Grand Cross of the Most Honorable Order of the
Bath, a Member of Her Majesty's Most Honorable Privy Council, Governor and Commander-in-Chief
of the Colony of New South Wales and its Dependencies.

TO ALL TO WHOM THESE PRESENTS SHALL COME, greeting :

WHEREAS THE CONSOLIDATED ELECTRIC COMPANY (Limited), of 110, Cannon-street, in the city
of London, England, hath by its Petition humbly represented to me that it is the Assignee (so far as the
Colony of New South Wales is concerned) of Joseph Samuel Beeman, William Taylor, and Frank King,
who are the authors or designers of a certain invention or improvement in manufactures, that is to say, of
an invention entitled "Improvements in Electric-current Measuring and Governing Apparatus," which is
more particularly described in the specification and the sheet of drawings which are hereunto annexed ;
and that the said Petitioner hath deposited with the Honorable the Treasurer of the said Colony of New
South Wales the sum of Twenty Pounds sterling, for defraying the expense of granting these Letters
of Registration, as required by the Act of Council, sixteenth Victoria, number twenty-four ; and hath
humbly prayed that I would be pleased to grant Letters of Registration, whereby the exclusive enjoyment
and advantage of the said invention or improvement might be secured to it for a period of fourteen
years : And I, being willing to give encouragement to all inventions and improvements in the arts or
manufactures which may be for the public good, and having received a report favourable to the prayer of
the said Petition, from competent persons appointed by me to examine and consider the matters stated
therein and to report thereon for my information, am pleased, with the advice of the Executive Council, and
in exercise of the power and authority given to me by the said Act of Council, to grant, and do by these
Letters of Registration grant unto the said Consolidated Electric Company, its successors and assigns, the
exclusive enjoyment and advantage of the said invention or improvement, for and during the term of
fourteen years from the date hereof ; to have, hold, and exercise unto the said Consolidated Electric
Company, its successors and assigns, the exclusive enjoyment and advantage thereof, for and during and
unto the full end and term of fourteen years from the date of these presents next and immediately ensuing,
and fully to be complete and ended : Provided always, that if the said Consolidated Electric Company
shall not, within three days after the granting of these Letters of Registration, register the same in the
proper office in the Supreme Court, at Sydney, in the said Colony of New South Wales, then these Letters
of Registration, and all advantages whatsoever hereby granted, shall cease and become void.

In witness whereof, I have hereunto set my sign manual, and have caused the present Letters of
Registration to be sealed with the seal of the said Colony of New South Wales, at Govern-
ment House, Sydney, in New South Wales, this twenty-second day of January, in the year of
our Lord one thousand eight hundred and eighty-four.

[L.S.]

AUGUSTUS LOFTUS.

Improvements in Electric-current Measuring and Governing Apparatus.

SPECIFICATION of the CONSOLIDATED ELECTRIC COMPANY (Limited), of 110, Cannon-street, in the city of London, in England, the assignee of the author or designer of an invention entitled "Improvements in Electric-current Measuring and Governing Apparatus."

THE apparatus constructed or arranged according to this invention for regulating or governing electric-currents consists of a suitable trough, containing any electrolyte, two or more conducting plates, both or all movable, or one set stationary, the other movable, all or any placed in a vertical, horizontal, or other direction. The plates, which may be solid, perforated, or built up, are to be moved and retained by suitable means in the desired position in the said trough, in which the electrolyte is maintained at a constant level, and convenient appurtenances are provided for retaining the plates in such desired position therein, so that by bringing the plates or sets of plates nearer to each other, or removing them to a greater distance from each other, or by immersing them more or less in the electrolyte, substantially in the manner hereinafter described, the current, passed through the electrolyte by means of the plate or sets of plates, is controlled and governed.

The means employed by us for moving and retaining the said plates, consist either of a rod or rods attached to the plates or the sets thereof, worked in a stuffing box, or by a rack and pinion, by springs, or by counter-balanced weights and pulleys, or by other equivalents, said appliances for moving being actuated automatically by a solenoid, with sucking magnet and spring, or by an electro-magnet or magnets, releasing one or more armatures, and thereby causing one or more electro-motors to work the appliances.

The following description of the drawings, part 1, illustrates the manner of performing the invention:—

A, represents a convenient generator; a and a' are the main conductors leading from generator; s and s' are the conductors leading from the said generator to a liquid resistance or bath containing electrolyte; H, I and I' are the plates or electrodes of the liquid resistance; J is an electro-motor attached to the plate, or plates, or electrode of liquid resistance, by either of the methods shown at fig. 2 or fig. 3. That shown at fig. 2 represents a drum fixed to the axle of the armature e of the electro-motor J, carrying a plate I', or plates, and its counterpoise by means of a cord. On the rotation of the armature e of the motor J, the plate or plates I' will rise or fall in accordance with the direction in which the armature of the motor rotates. In fig. 3 the armature shaft of the motor is attached to a worm, or screw U, carrying a screwed sleeve t , from which is suspended the plate or plates I'. On rotation of the armature e of the motor J in either direction, the worm or screw U will rotate, and the plate or plates will rise or fall in the liquid H, according to the direction of the rotation of the armature, having in this the advantage of causing the plate or plates, or electrodes, to approach each other, as well as immersing them in the electrolyte or liquid resistance, thereby making the apparatus more sensitive than where immersion is effected by the drum and cord method, as shown in fig. 2.

Fig. 1 is elevation of the automatic apparatus, for detecting any abnormal difference in potential between the poles G and G', or their attached conductors a and a' , and fig. 2 contains a plan view of the same, showing connections to the electro-motor J for adjusting the liquid resistance H to the requirements at any time existing.

B F are electro-magnets wound with fine wire having very high resistance, and connected to the main conductor a , through x , round F, thence along x' , round B, along x'' to a' ; C and E are levers, having armatures attached, the said levers having attachments by which contact may be made with the mercury cups D k l , or their equivalents.

The drawing as a whole shows the apparatus in position, when the difference of potential at the poles of the generator G and G', or the attached conductors a and a' , is at its normal. When the difference of potential between the poles of the generator G and G', or the attached conductors a and a' , falls below the normal, the electro-magnet B releases its armature attached to the lever C, and the weight W causes the said lever C to fall, as shown by the dotted lines, and make a circuit through the electro-motor J; a current then passes from the main conductor a along the wire b to the contact D and lever C, and thence along the wire c to the electro-motor J, entering at the brush d of the motor, passing through the armature of the motor e to the brush of the motor f , thence to terminal g , through fields of the motor to the terminal h , along the wire i to the main conductor a' .

The connections as above described convert the electro-motor J into a "series" motor, and the armature e rotates in such a direction as will cause the immersion, as in fig. 2, of the plate or plates, or as in fig. 3, the immersion and approach of said plates. This immersion of the plate having the effect of lessening the liquid resistance, more current will flow through the conductor on field magnets of the generator A, thereby causing a rise in the potential generated by the armature of the generator A. During the process of a rise in potential between poles of the generator G and G', or their attached conductors a and a' , and when the normal potential is reached, the armature attached to the lever C will be attracted by the electro-magnet B, and the circuit containing the motor will be broken at the mercury cup D, leaving, by the cessation of the rotation of the armature e , the plate or plates I', in the required position.

If now, the difference of potential between the poles of the generator G and G', or attached conductors a and a' , rise above the normal, not only will the armature attached to lever C remain attracted by the electro-magnet B, but the armature attached to the lever E will also be attracted to the electro-magnet F, as indicated by the dotted lines; and the attachment of the said lever will make a circuit through the mercury cups k and l ; a current will now flow from the main conductor a , along the wire m to the terminal n , along the helical coil thereto attached to mercury cup k , thence along o to the brush f and terminal g of the electro-motor J, thence into the field magnets and armature in parallel arc to d and h , thence from h through i to a' , and also from d through c' , resistance g^2 , along p to the lever E, thence to mercury cup l , along wire r to a' . The connections have now converted the electro-motor J into a shunt dynamo, and the armature will rotate in the reverse direction, and thus raise the plate or plates I', as in fig. 2, or withdraw and raise the plate or plates I, as in fig. 3; and this operation, by increasing the liquid resistance, will lower the current passing into the conductor on the field magnets of generator A, thereby lowering the potential generated by the armature, until the difference of potential between G and G' or a and a' reaches the normal, when the armature attached to the lever E will be released,

Improvements in Electric-current Measuring and Governing Apparatus.

released, and the weight W^1 will raise the attachments to the lever E , and so break the contact with the mercury cups k l , leaving the motor stationary, and the plates in the liquid resistance in the position required by the conditions. The electrolyte composing the liquid resistance is retained at a constant level.

When the motor is connected as shunt, a resistance is inserted at e^2 , with the object of equalizing the amounts of current which the motor receives when connected, either as "series" or "shunt."

In place of the armature attached to the levers E and C being attracted by their electro-magnets F and B , the said magnets F and B may be replaced by solenoids, and the armatures lengthened to hang or be drawn in the solenoids.

The invention also relates to an arrangement wherein a solenoid and a sucking-magnet with a counter-balancing spring, or an electro-motor or motors with armatures, is capable of being moved, operating by means of any suitable mechanical device, such as a pencil or style, brought into contact with paper or other equivalent, and so marking the movements of the sucking-magnet or electro-motor and its attachments, put into motion by the electric current passed through the coils of the solenoid or the electro-motor. The paper or material to be so marked is made in a continuous roll or rolls, and is actuated by clock mechanism, or in lieu of the clock mechanism, the movement of the paper may be effected by an electro-motor, and thus the duration, as well as the force and quantity of the current, registered. The clock mechanism is so arranged that, when it is desired to turn on a current to light any lamp, motion is first given to a clock, which by its impactive movement then closes the circuit, so as to send a current along a main wire, and immediately the clock runs down, the current is automatically cut off. The apparatus may be situated on the premises where the electricity is used, and thus serve as a meter for gauging the consumption. Fig. 4 and the succeeding figures serve to illustrate the manner of performing the invention.

A , fig. 4, represents a solenoid; B is a sucking-magnet, carrying coils of fine wire; C D is a spiral spring for regulating the distance to which the sucking-magnet B is drawn into the solenoid A by variations in the intensity of the current; E is a multiplying arc, to which is attached the cords F F^1 . The cord F is attached to the sucking-magnet B , and the cord F^1 is attached to a pencil carrier G , the latter having a motion between a pair of rails H , or their equivalent, and marking a curve or other line upon the paper. I , is a roll of paper, said paper roll being unwound and drawn along under the pencils or styles by the studded roller J (as shown in plan in fig. 4^A), which said studded roller may be actuated, either by direct attachment to a clock, or by means of the electro-magnet, fig. 5; k is a pencil or style, and holder to mark zero line on the paper as it is drawn along by the studded roller J . Fig. 6 shows another arrangement by which the arc E may be dispensed with, and in its place the slotted bar E^1 may be actuated from the sleeve L ; but evidently any parallel motion may be used without departing from the nature of the invention.

The electro-motor, fig. 5, is actuated by the contact-breaker, fig. 7, which is made to form part of any clock mechanism, and is so arranged that, at every revolution of the wheel M , a contact is made through the hanging rod N , and the mercury in the cup O , round the electro-magnet P , fig. 5. When the electro-magnet P is excited as described, it will attract the armature Q , which actuates the click or pawl R , thereby giving motion to the ratchet-wheel S , the latter being attached to the studded roller J , figs. 4 and 4^A. Fig. 8 represents a method of setting the clock in motion directly any current is required, the detent T being actuated by the magnet U gives an impulse to the toothed balance-wheel V , the detent T being kept clear of the toothed-wheel by the attraction of the electro-magnet U on its armature; W is an ordinary switch. Fig. 9 shows a governor actuated by the motion of the clock; when the said governor rotates, it acts upon the lever a at a^1 , causing the contact piece f , connected to the said lever, to enter the mercury cup b , and so complete the main circuit; x and y are the points where connection is made with the source of supply employed for supplying electricity to the place where the improved apparatus is used, and which we term generator points. The action of the apparatus is as follows:— Upon completion of the circuit by means of the switch W , the current passes along the shunt wire e round the sucking-magnet coils C , fig. 4, and thence round the electro-magnet U , fig. 8, and thereby setting the clock in motion, of which V is the balance-wheel, the said clock actuating, as before described, the roller J , and the said roller moving the paper, the clock at the same time actuating the governor, fig. 9, and completing or making contact through the main circuit through the lamp or translating device d . The circuit being complete, the current now passes along the main conductor e , through the lever a , mercury cup b , extension of main conductor e^1 through lamp or translating device d , and continuation of main conductor e^2 through switch W and along e^3 , through solenoid coils A , fig. 4, to the generator. It will be seen that upon the completion of the main circuit, as before described, the solenoid will draw the sucking-magnet into its core, so as to actuate the multiplying arc E , fig. 4, or its equivalent, thus giving motion to the pencil carrier G along the rails H by means of the cord F , thereby recording on the paper the amount of current that is passing in the circuit, at the same time the clock is giving motion to the paper. It will be seen that, on the motion of the pencil according to the variation in the strength of the current combined with the movement of the paper in a direction perpendicular to the movement of the pencil, a diagram will be produced showing the amount of current that has been passing during any given time.

We claim as the invention:—

First—The combination of parts forming apparatus for governing or regulating electric currents, substantially as described and illustrated in figs. 1, 2, and 3 of the drawings for the purposes set forth.

Second—The method of conversion of any suitable motor into a "series" or shunt-motor, whereby the rotation of the armature is obtained in either direction for the purpose of moving, adjusting, or retaining in position the electrodes employed, substantially as described and illustrated by figs. 1, 2, and 3 of the drawings.

Third—The combination of a motor screw and attachments for giving motion to one or more electrodes, substantially in the manner and for the purposes described with reference to fig. 3 of the drawings.

Fourth—

Improvements in Electric-current Measuring and Governing Apparatus.

Fourth—The combination of parts forming the apparatus for measuring electric force and currents, substantially as described and illustrated in figs. 4 to 9 of the drawings.

Fifth—The combination consisting of mechanism for starting a clock, a clock and contact making and breaking apparatus, used for breaking and closing the main circuit, substantially as described and illustrated with reference to figs. 4 to 9 of the drawings.

Sixth—The combination of a shunt-wire connected with one of the main conductors and a generator point, whereby any switch in the main circuit being actuated will start the clock and close the main circuit, substantially as described and illustrated with reference to the said figures 4 to 9.

THE CONSOLIDATED ELECTRIC COMPANY (LIMITED).
(By their Agent, EDWD. WATERS.)

Witness—

W. S. BAYSTON,
Patent Law Clerk, Melbourne.

This is the specification referred to in the annexed Letters of Registration granted to the Consolidated Electric Company (Limited), this 22nd day of January, A.D. 1884.

AUGUSTUS LOFTUS.

REPORT.

Sir,

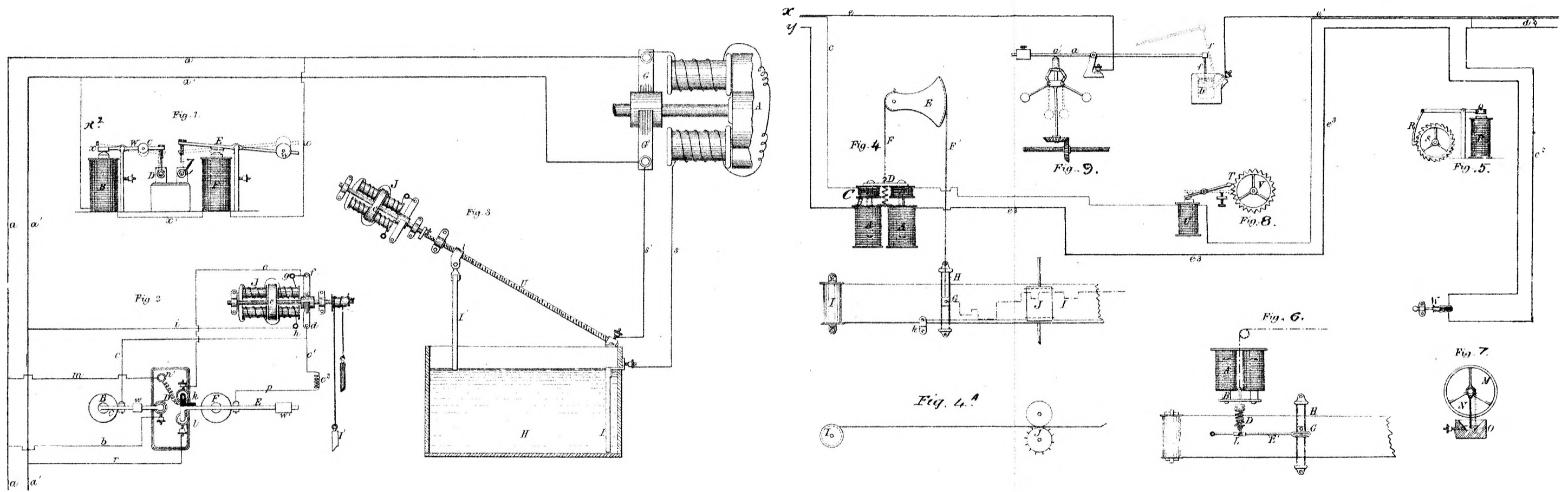
The application for Letters of Registration from the Consolidated Electric Company, 83-10,987, has been examined by us, and we see no reason why the petition should not be granted for their "Improvements in Electric-current Measuring and Governing Apparatus."

We have, &c.,

E. C. CRACKNELL.
H. C. RUSSELL.

The Under Secretary of Justice.

[Drawings—one sheet]



This is the Sheet of Drawings referred to in the annexed Letters of Registration, granted to the Consolidated Electric Company (limited), the twenty second day of January, A.D., 1884.

Augustus Loftus.

(Sig: 245~)



A.D. 1884, 22nd January. No. 1372.

IMPROVEMENTS IN MACHINERY FOR SINKING SHAFTS AND TUNNELLING
UNDER WATER OR THROUGH TREACHEROUS GROUND.

LETTERS OF REGISTRATION to Joseph Husband and William Wright, for
Improvements in Machinery for Sinking Shafts and for Tunnelling under Water
or through Treacherous Ground.

[Registered on the 23rd day of January, 1884, in pursuance of the Act 16 Vic. No. 24.]

BY HIS EXCELLENCY THE RIGHT HONORABLE SIR AUGUSTUS WILLIAM FREDERICK SPENCER LOFTUS
(commonly called LORD AUGUSTUS LOFTUS), Knight Grand Cross of the Most Honorable Order of
the Bath, a Member of Her Majesty's Most Honorable Privy Council, Governor and Commander-in-
Chief of the Colony of New South Wales and its Dependencies.

TO ALL TO WHOM THESE PRESENTS SHALL COME, greeting :

WHEREAS JOSEPH HUSBAND, of Waverley, in the Colony of New South Wales, works overseer, and
WILLIAM WRIGHT, of Waverley aforesaid, works overseer, have by their Petition humbly represented to
me that they are the authors or designers of a certain invention or improvement in manufactures, that is to
say, of an invention entitled, "Improvements in Machinery for Sinking Shafts and for Tunnelling under
Water or through Treacherous Ground," which is more particularly described in the specification, marked
A, and the two sheets of drawings, marked B and C respectively, which are hereunto annexed; and that
they, the said Petitioners, have deposited with the Honorable the Treasurer of the said Colony of New
South Wales the sum of Twenty Pounds sterling for defraying the expense of granting these Letters of
Registration, as required by the Act of Council, sixteenth Victoria, number twenty-four, and have humbly
prayed that I would be pleased to grant Letters of Registration whereby the exclusive enjoyment and
advantage of the said invention or improvement might be secured to them for a period of fourteen years.
And I, being willing to give encouragement to all inventions and improvements in the arts or manufac-
tures which may be for the public good, and having received a report favourable to the prayer of the said
Petition from competent persons appointed by me to examine and consider the matters stated therein and
to report thereon for my information, am pleased, with the advice of the Executive Council, and in exercise
of the power and authority given to me by the said Act of Council, to grant, and do by these Letters of
Registration grant unto the said Joseph Husband and William Wright, their executors, administrators,
and assigns, the exclusive enjoyment and advantage of the said invention or improvement, for and during
the term of fourteen years from the date hereof; to have, hold, and exercise unto the said Joseph Husband
and William Wright, their executors, administrators, and assigns, the exclusive enjoyment and advantage
thereof, for and during and unto the full end and term of fourteen years from the date of these presents next
and immediately ensuing, and fully to be complete and ended: Provided always, that if the said Joseph
Husband and William Wright shall not, within three days after the granting of these Letters of Registration,
register the same in the proper office in the Supreme Court, at Sydney, in the said Colony of New South
Wales, then these Letters of Registration, and all advantages whatsoever hereby granted, shall cease and
become void.

In witness whereof, I have hereunto set my sign manual, and have caused the present Letters of
Registration to be sealed with the seal of the said Colony of New South Wales, at Government
House, Sydney, in New South Wales, this twenty-second day of January, in the year of our
Lord one thousand eight hundred and eighty-four.

[L.S.]

AUGUSTUS LOFTUS.

Improvements in Machinery for Sinking Shafts & Tunnelling under Water, &c.

A

SPECIFICATION of JOSEPH HUSBAND, of Waverley, works overseer, and WILLIAM WRIGHT, of Paddington, works overseer, in the Colony of New South Wales, for an invention entitled "Improvements in Machinery for Sinking Shafts and for Tunnelling under Water or through Treacherous Ground."

Our invention relates to that class of machinery for sinking shafts, and for tunnelling under water or through treacherous ground, in which a contrivance, technically termed a "shield," is forced through the ground in advance of the lining of the shaft or tunnel, and has been designed more particularly for tunnelling through treacherous ground, wet or dry, and for more expeditiously performing such work than has hitherto been possible.

Our improvements consist essentially in the peculiar construction of the shield, or advancing contrivance, which has a spring ring of peculiar construction for embracing the completed lining, a cutter of novel construction, and the smooth face of the shield made up of panels or shutters.

The shield consists of a hollow angular cutter, made preferably of steel, and in which an outer sharpened cylinder, a little larger in diameter than the completed tunnel or shaft, and an inner tapered cylinder, also sharpened, meet at their points, while their other ends are secured by angle-irons to a circular plate. To the back of this plate, by means of another angle-iron, is attached the spring ring, which is made up of narrow tapering strips of steel secured to said back angle-iron, and to a ring-stay a little behind it. The open space bounded by the back plate of the cutter is filled in when required by horizontal flush panels, or shutters back by bridge stays; and some of these panels have holes on which cocks or valves are affixed, and said panels being so constructed and fixed in position that one or other of them may be removed at will.

But in order that the invention may be clearly understood reference will now be made to the drawings, in which figure 1 is a sectional view of a tunnel lined with cast-iron cylinders, in advance of which our improved shield is seen also in section. Figure 2 is front view and figure 3 back view of the shield, while figure 4 is detail views of one of the narrow strips which make up the spring ring. Figures 5 and 6 are similar views on a larger scale to figures 1 and 3.

A is the outer cylinder of the cutter, B the spring ring, and C the panels; A¹ is the inner tapering cylinder of the cutter, and A² the back plate; B¹ is the back angle-iron, and B² the ring-stay to which the narrow strips B are secured; C¹ are bridge-stays of the panels secured to plate A², and C² are cocks upon some of the panels; D are hydraulic pumps, and E the lining of the complete tunnel.

In operation a length of lining E is built within spring ring B, and, if intended to tunnel or sink through wet ground, panels C are placed in position and cocks C² opened. The shield is then forced forward by hydraulic pumps D, when the water and mud or sand will flow through cocks C² into trucks, which in a tunnel are placed at the back, as clearly shown in figures 1 and 3, and if any root or other hard obstruction is met with the panel nearest to it may be taken out while it is cut out or otherwise removed. When the shield has advanced, say, one length of lining, a second length is built up in sections within spring ring B, and the shield is advanced so that a third length of lining may be similarly put in, and so on.

Should the ground through which the tunnel or shaft is being made be neither wet nor wet enough for the material to flow through the cocks the panels C may be dispensed with, and in this case the workmen may excavate within the space surrounded by the cutter without being in danger of the earthwork falling in upon them.

Having thus particularly described and ascertained the nature of the said invention, and the manner in which the same is to be performed, we would have it understood that we do not confine ourselves to the materials of which any parts of our contrivance may be constructed, nor to any particular size, or to any particular kind of lining of the tunnel or shaft, nor to any method of advancing the shield; and also that we do not claim, broadly, sinking shafts or tunnelling by means of an advancing shield; but what we claim as our improvements in machinery for sinking shafts or tunnelling under water or through treacherous ground is—

First—The spring ring B, made up of narrow strips for embracing the completed lining of a tunnel or shaft, substantially as herein described and explained.

Second—The hollow angular cutter made up of cylinder A, tapered cylinder A¹, and circular plate A², substantially as herein described and explained.

Third—Making the flush face of the shield of panels so that one or other may be removed, substantially as herein described and explained.

Fourth—The particular combination and arrangement of parts forming a shield, substantially as herein described and explained, and as illustrated in the drawings.

In witness whereof, we, the said Joseph Husband and William Wright, have hereto set our hands.

EDWARD WATERS, 6, Bridge-street,
Agent for Applicants.

JOSEPH HUSBAND.
WILLIAM WRIGHT.
(By their Agent, FRED. WALSH.)

This is the specification marked A referred to in the annexed Letters of Registration granted to Joseph Husband and William Wright, this twenty-second day of January, A.D. 1884.

AUGUSTUS LOFTUS.

REPORTS.

Improvements in Machinery for Sinking Shafts & Tunnelling under Water, &c.

REPORTS.

Sir,

Sydney, 18 July, 1883.

We do ourselves the honor to report, in reply to your blank cover of the 26th ultimo, No. 7,762, that we find Messrs. Joseph Husband and William Wright's specification and drawings of an invention entitled "A Shield for Working Bad Ground" too inexplicit and indefinite to enable us to report definitely upon their claim for registration, and we desire to point out that the claim set forth should embody the specific mechanical or other novelty in the invention, in place of its utility.

We have, &c.,

JAMES BARNET.

GOTHER K. MANN.

The Under Secretary of Justice.

Sir,

Sydney, 15 August, 1883.

We do ourselves the honor to report, in reply to your blank cover of the 4th instant, No. 9,789, transmitting Messrs. Husband and Wright's amended specification, drawing, and claim for an invention entitled "A Shield for Working Bad Ground," that we are of opinion the prayer of the Petitioners may now be granted

We have, &c.,

JAMES BARNET.

GOTHER K. MANN.

The Under Secretary of Justice.

[Drawings—two sheets.]

HUSBAND AND WRIGHT'S PATENT

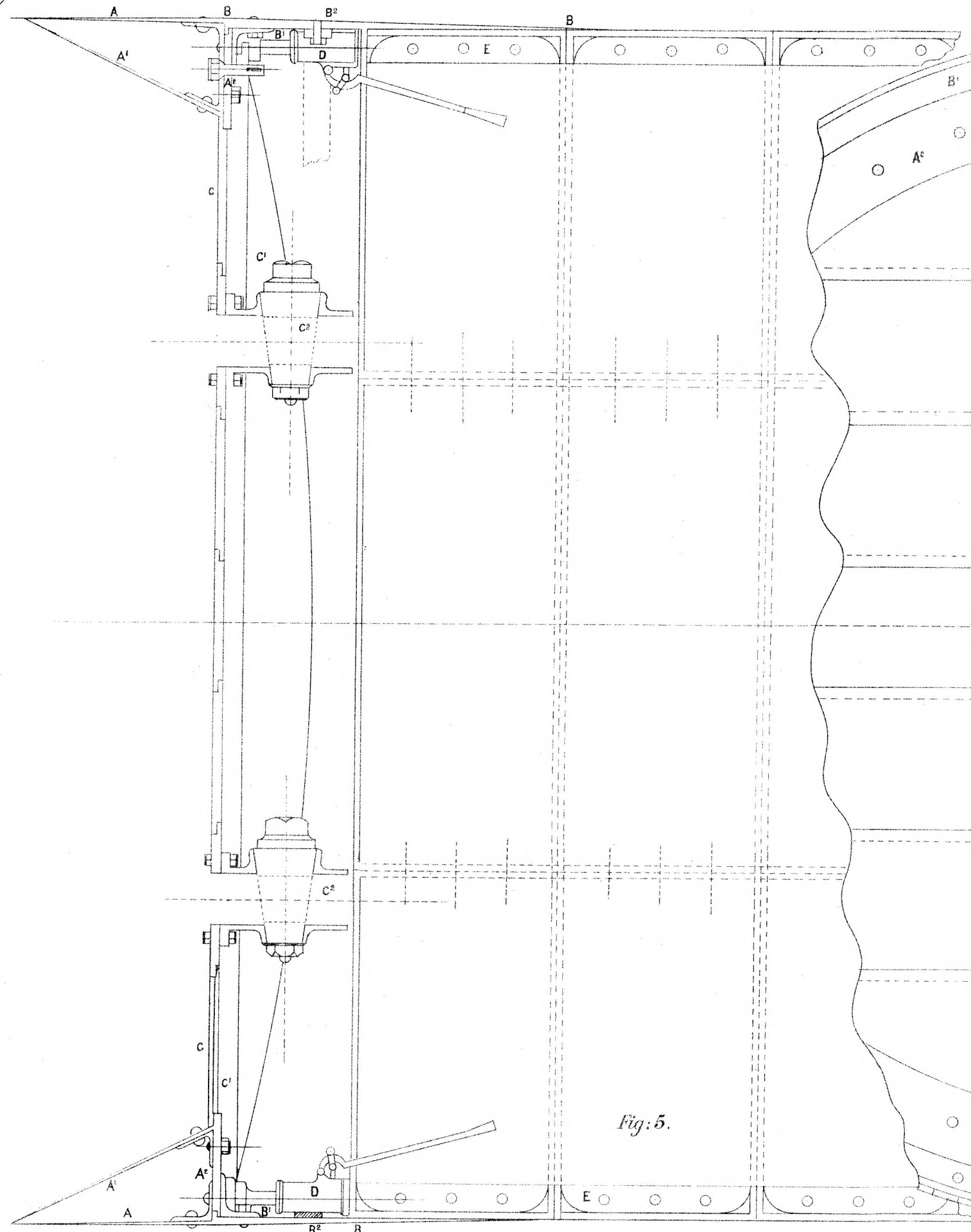


Fig. 5.

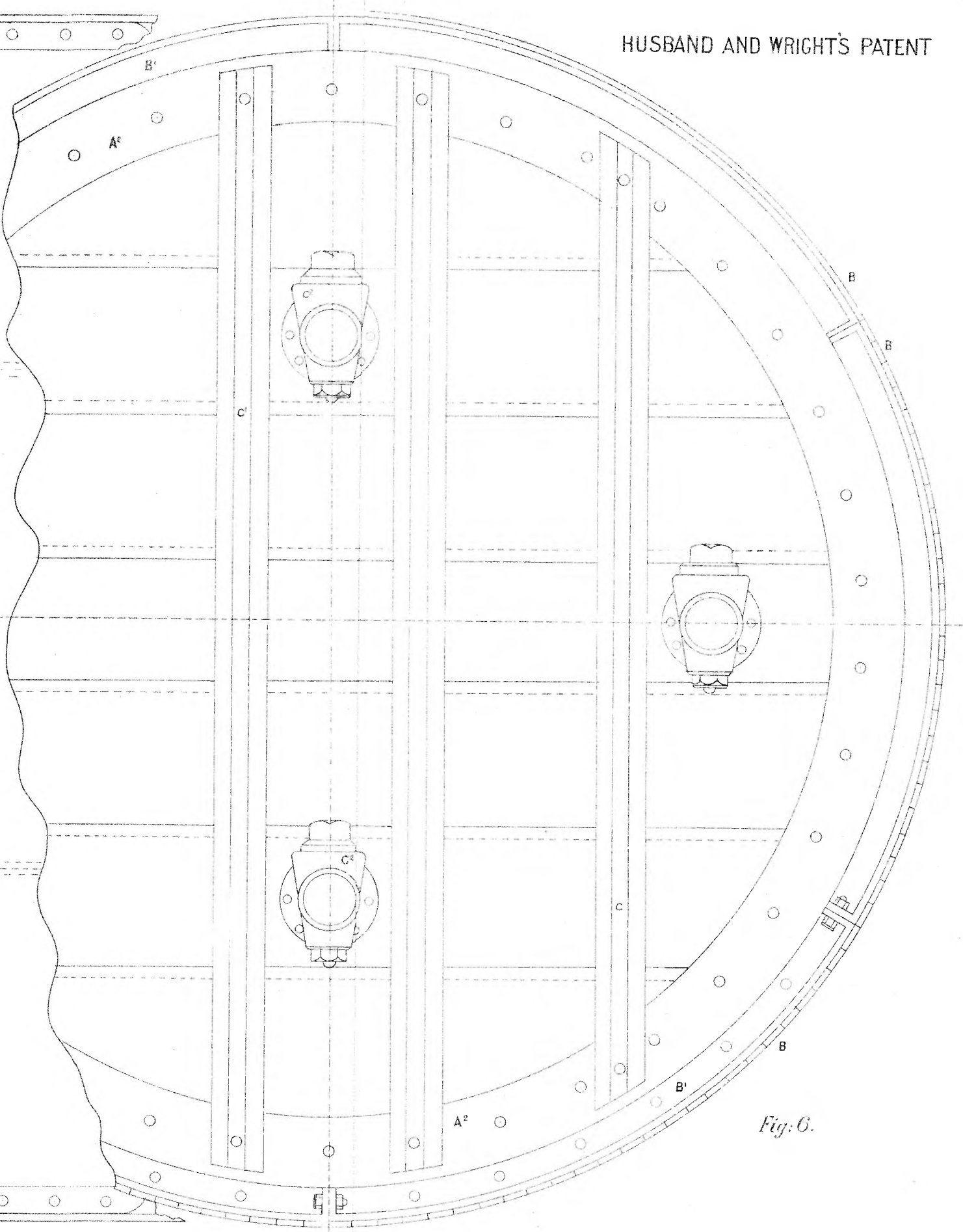
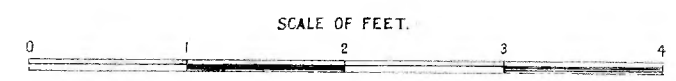


Fig. 6.

This is the sheet of Drawings marked "C" referred to in the annexed Letters of Registration granted to Joseph Husband and William Wright, this twenty-second day of January A. D., 1884.

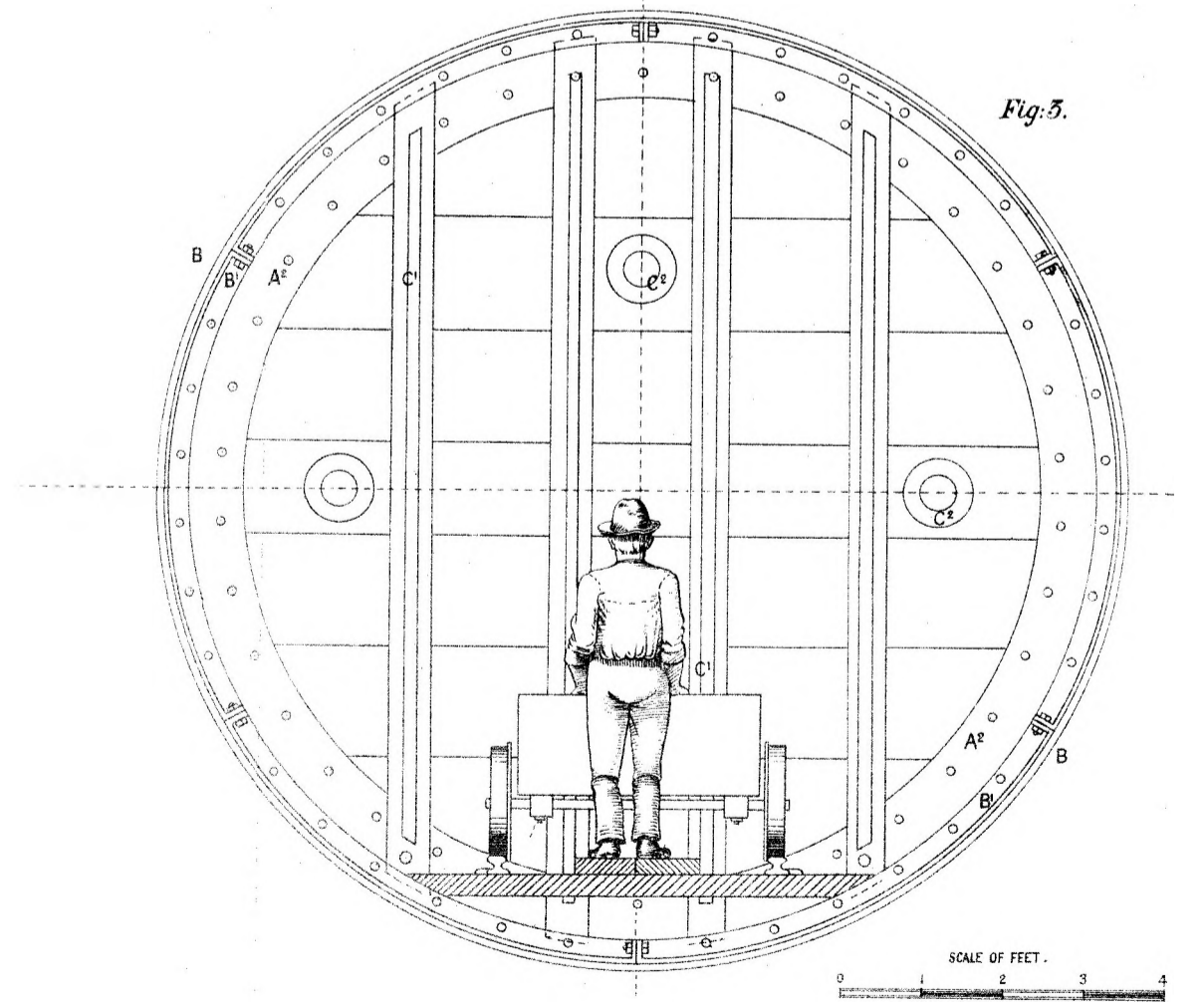
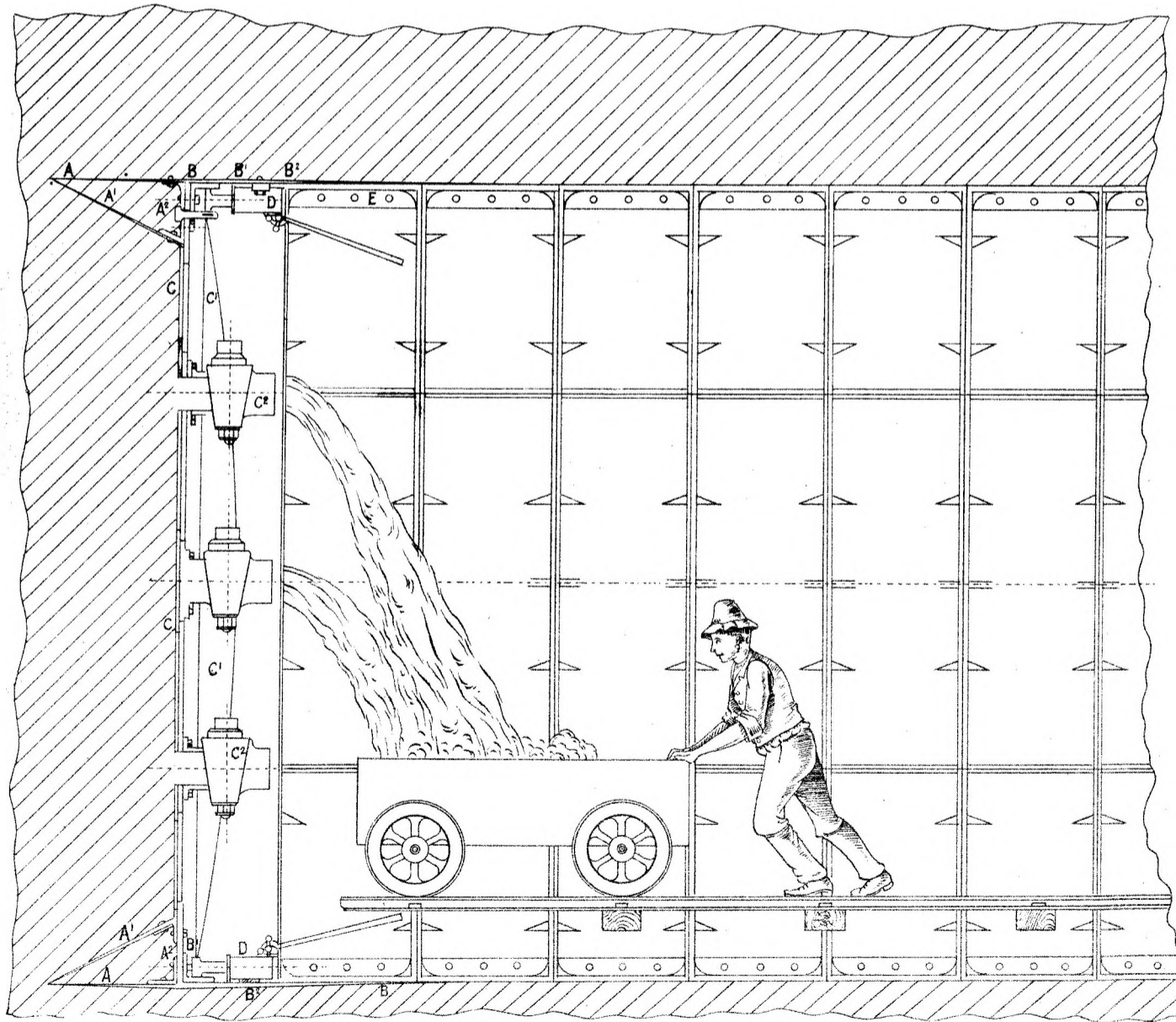
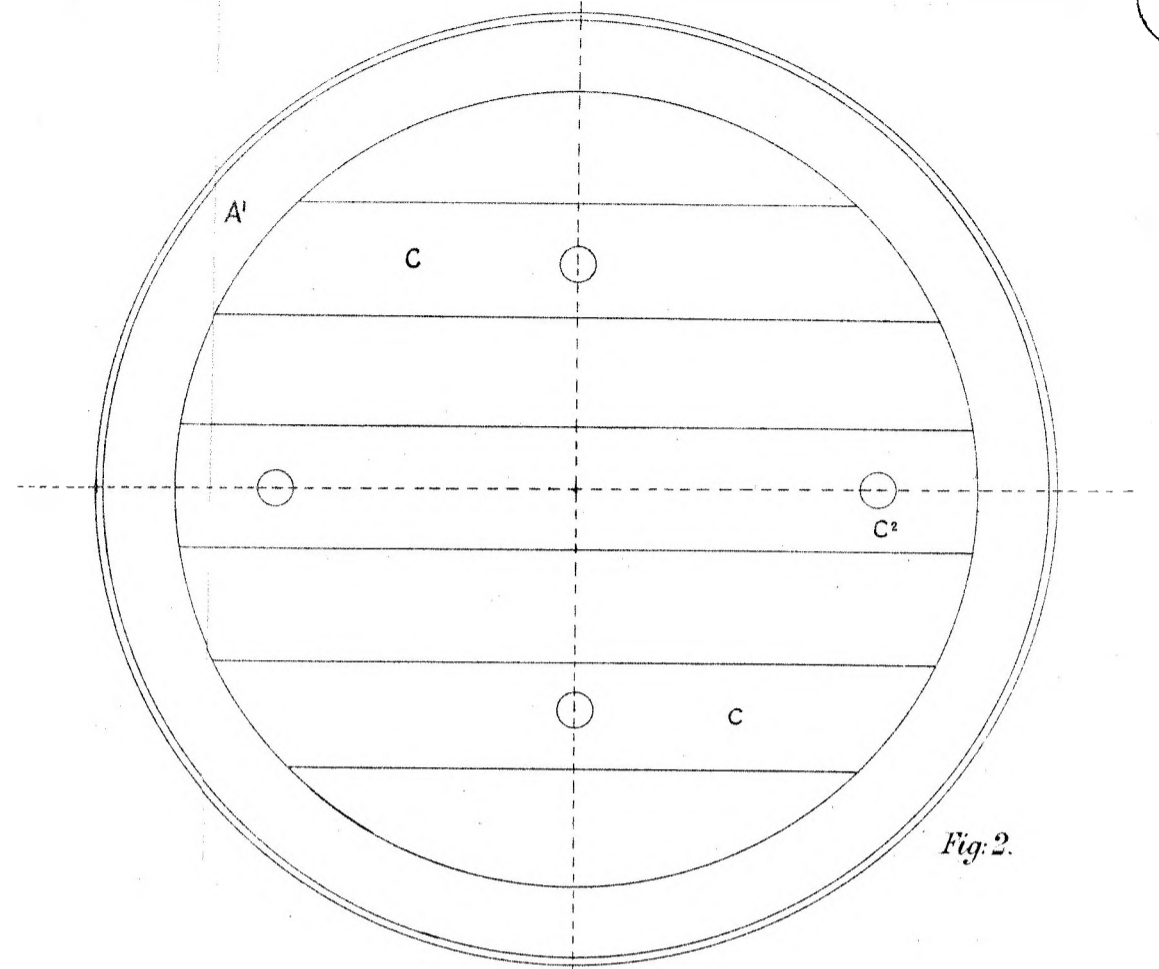
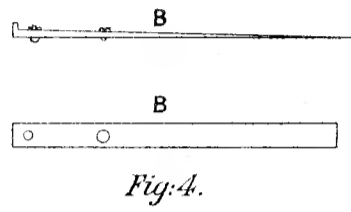
Augustus Loftus.



HUSBAND AND WRIGHT'S PATENT.

This is the sheet of Drawings marked "B" referred to in the annexed Letters of Registration granted to Joseph Husband and William Wright, this twenty-second day of January, A.D., 1884.

Augustus Loftus.





A.D. 1884, 22nd January. No. 1373.

IMPROVEMENTS IN MACHINERY OR APPARATUS FOR THE MANUFACTURE OF HORSE-SHOE NAILS.

LETTERS OF REGISTRATION to The Acme Horse-shoe Nail Company (Limited), for Improvements in Machinery or Apparatus for the manufacture of Horse-shoe Nails.

[Registered on the 23rd day of January, 1884, in pursuance the Act of 16 Vic. No. 24.]

BY HIS EXCELLENCY THE RIGHT HONORABLE SIR AUGUSTUS WILLIAM FREDERICK SPENCER LOFTUS (commonly called LORD AUGUSTUS LOFTUS), Knight Grand Cross of the Most Honorable Order of the Bath, a Member of Her Majesty's Most Honorable Privy Council, Governor and Commander-in-Chief of the Colony of New South Wales and its Dependencies.

TO ALL TO WHOM THESE PRESENTS SHALL COME, greeting :

WHEREAS THE ACME HORSE-SHOE NAIL COMPANY (Limited), of Abchurch-lane, in the city of London, England, hath by its Petition humbly represented to me that it is the assignee (so far as the Colony of New South Wales is concerned) of Lyman W. Whipple, of Boston, America, who is the author or designer of a certain invention or improvement in manufactures, that is to say, of an invention entitled "Improvements in machinery or apparatus for the manufacture of Horse-shoe Nails," which is more particularly described in the amended specification and the sheet of drawings which are hereto annexed; and that the said Petitioner hath deposited with the Honorable the Treasurer of the said Colony of New South Wales the sum of Twenty Pounds sterling for defraying the expense of granting these Letters of Registration, as required by the Act of Council, sixteenth Victoria, number twenty-four; and hath humbly prayed that I would be pleased to grant Letters of Registration, whereby the exclusive enjoyment and advantage of the said invention or improvement might be secured to it for a period of fourteen years: And I, being willing to give encouragement to all inventions and improvements in the arts or manufactures which may be for the public good, and having received a report favourable to the prayer of the said Petition, from competent persons appointed by me to examine and consider the matters stated therein and to report thereon for my information, am pleased, with the advice of the Executive Council, and in exercise of the power and authority given to me by the said Act of Council, to grant, and do by these Letters of Registration grant unto the said Acme Horse-shoe Nail Company, and its successors and assigns, the exclusive enjoyment and advantage of the said invention or improvement, for and during the term of fourteen years from the date hereof; to have, hold, and exercise unto the said Acme Horse-shoe Nail Company, and its successors and assigns, the exclusive enjoyment and advantage thereof, for and during and unto the full end and term of fourteen years from the date of these presents next and immediately ensuing, and fully to be complete and ended: Provided always, that if the said Acme Horse-shoe Nail Company shall not, within three days after the granting of these Letters of Registration, register the same in the proper office in the Supreme Court, at Sydney, in the said Colony of New South Wales, then these Letters of Registration, and all advantages whatsoever hereby granted, shall cease and become void.

In witness whereof, I have hereto set my sign manual, and have caused the present Letters of Registration to be sealed with the seal of the said Colony of New South Wales, at Government House, Sydney, in New South Wales, this twenty-second day of January, in the year of our Lord one thousand eight hundred and eighty-four.

[L.S.]

AUGUSTUS LOFTUS.

Improvements in Machinery or Apparatus for the manufacture of Horse-shoe Nails.

SPECIFICATION of THE ACME HORSE-SHOE NAIL COMPANY (Limited), of No. 25, Abchurch-lane, in the city of London, for Improvements in machinery or apparatus for the manufacture of Horse-shoe Nails.

THE invention has for its object to provide an automatic machine adapted to rapidly form a cold rolled horse-shoe nail from a strip or plate, by successive punching, rolling, and finishing operations, without releasing the nail blank or allowing it to change its position by gravitation or accident until it is finished, thereby insuring the proper position of the blank with reference to the mechanism which imparts to it its successive changes of form. The invention also has for its object to provide an automatic machine, whereby two or more nail blanks can be punched simultaneously from a single plate and formed simultaneously by successive operations into completed nails without being released until finished.

Of the accompanying drawings forming a part of this specification, figure 1 represents a front elevation of a machine embodying the invention; fig. 2 represents a side elevation of the same; fig. 3 represents a plan; fig. 4 represents a section taken along the line xx , fig. 2, looking downwardly; fig. 5 represents a section taken along the line yy , fig. 2, looking upwardly; fig. 6 represents a section taken along the line zz , fig. 2; fig. 7 represents a section in line $z'z'$. The remaining figures represent views of parts in detail.

In the drawings, A represents the general framework of suitable construction to support the parts hereinafter described. At the foot of the frame is a gang of punches BB, two in number. These are attached to a crosshead C, which is reciprocated vertically in guides in the frame A by eccentrics DD on a shaft E, the said eccentrics being connected to the crosshead by rods FF. The punches BB are formed to cut separate blanks, B' approximating to the shape of a horse-shoe nail, from a nail, strip, or plate, the said punches co-operating with corresponding female dies GG in a stationary block H, and forcing the blanks downwardly through the said dies, which are provided with suitable springs a^2 , whereby the accumulated blanks are prevented from falling. The punches are so arranged that of the blanks cut at one descent of the punches, the head of one will be adjacent to the point of the other. The plate I is presented to the punches by an automatic feeding device composed of a reciprocating bed J, and a shoe J' pivoted at K to ears on the bed and adapted to swing vertically, the plate I being inserted between the bed and shoe. The bed J reciprocates the fixed guides, and is moved by a cam L on the shaft E, and a lever M pivoted at N to the frame A, and at O to the bed J, and held by a spring P in contact with the surface of the cam. The approach of the bed to the punches is limited by adjustable screws Q; S is a cam journalled in blocks on the bed J, and operated to intermittently depress the shoe J' by a crank T, a connecting rod U, and a cam groove V in a disc on the shaft E. The shoe is pressed down and the bed and shoe are moved forward while the punches are raised, the plate being thus moved forward. When the plate is moved forward the bed and shoe stop and grip the plate until the punches enter it, the shoe is then released by the cam S, and the bed moves back, while the plate is transfixed by the punches. The cam S is supported entirely by the bed, and therefore does not increase the pressure of the bed upon its guides when it is bearing down upon the shoe.

The shoe J' interposed between the cam S and the nail plate resting on the bed J receives the pressure of the cam, and prevents the latter from displacing or moving the plate when it is rotated to clamp the plate. If the cam was allowed to come directly in contact with the plate it would have a tendency to move the plate, particularly when the latter is nearly consumed, and is therefore so light as to be easily moved.

aa represent a pair of rolls, which I term a rolling former, each roll having a cavity b cut in its periphery, the said cavities constituting rolling dies to form and move forward a nail blank. There may be any desired number of these rolling formers arranged in a series, each adapted to impart a different form to a nail blank, and there should be as many series of rolling formers as there are punches BB. There are two series in the present example (one being marked 11 and the other 22), and each series is composed of two pairs of rolls aa ; the said rolls are attached to shafts cc arranged in pairs, as shown in fig. 7. The rolls a project outside of the frame A, so that they can be readily seen; the shafts of each pair are geared together, and the lower shafts mesh with two sectors dd which mesh with each other. One of the sectors d is provided with a crank e connected by a rod f with a crank g on the driving shaft E, and the sectors are thereby oscillated, and caused to oscillate or vibrate the rolls aa . The rolls on each pair of shafts I term a gang of formers, and the two pairs in each gang are constructed to impart substantially the same form simultaneously to two blanks. F¹F¹ represent what I call distributing forwarders; they are composed of curved and bent arms hh and separable spring jaws ii on the said arms. The arms hh are located on vertical spindles jj , which are adapted both to rotate and move vertically in bearings in the frame A. The spindles are rotated by a reciprocating double rack k engaging with pinions ll on the spindles as shown in fig. 5, and reciprocated by a cam m and spring n , the cam forcing the rack in one direction and the spring pressing the rack against the cam, the rack rotates the spindles jj first in one direction and then in the other, causing the forwarders to swing back and forth horizontally. The spindles are raised by a rock shaft o journalled in fixed bearings in the frame A, and provided with arms pp bearing against collars q on the spindles, and an arm r bearing against a rotary cam s , the rock shaft is worked by the rotation of the cam s , and caused to intermittently lift the spindles s . Springs tt on the spindle press the latter downwardly and keep the arm r of the rock shaft in contact with the cam s . By the described mechanism the forwarders F¹F¹ (supposing the same to be in the position shown in figures 2, 3, and 4) are moved horizontally to points under the dies GG, then raised to grasp the blanks that are at the same moment forced out of the said dies by the punches then depressed, and caused to leave the said dies and finally moved horizontally to the positions shown in figures 2, 3, and 4, and thus caused to present the blanks to the first gang of rolling formers, which are then vibrated so as to grasp the blanks, draw them from the forwarders F¹ and move them forward, forming them at the same time and forcing them into two forwarders F²F², which are waiting at the opposite sides of the first rolls aa . The forwarders F²F² consist of separable spring jaws $vvvv$, supported on the upper ends of levers uu , which are pivoted to the frame A at w , and their lower ends are rigidly connected by a transverse rod x ; the said rod is held in a socket y , on a sliding bar z , which is supported in guides a^1a^1 on the frame A, and is reciprocated by a cam b^1 and a spring c^1 , so as to oscillate the levers uu on their pivot and move the forwarders F² F² back and forth between the rolling formers in such a manner that when the nail blanks are released by the first gang of rolls the forwarders F²F² will move them to the second gang

Improvements in Machinery or Apparatus for the manufacture of Horse-shoe Nails.

gang of rolls, by which the said blanks will be grasped, removed from the forwarders, formed and forced into two succeeding forwarders F^1F^2 , to be hereinafter described, which moves the nail blanks from the last gang of rolling formers to the clippers or trimming dies h^1h^2 . Each of the said dies consists of a vertically reciprocating punch 3, having the exact outline of a completed nail and a correspondingly formed female die in a bed or block attached to the frame A; the said clippers are adapted to trim and remove the web or pin formed on a nail blank by the rolling formers. Over the die 4 of each clipper is located a pair of jaws or nippers i^1 , which I term false jaws. These are adapted to open to permit a nail head to be inserted between them, and are formed with hooks or shoulders j^1j^2 , which close against the shank of the nail behind the head after the latter has passed the said shoulders. The false jaws hold the nail in the proper position relatively to the punch and die constituting each clipper, and form stops which limit the forward movement of the nails. The punches 33 are attached to a vertically reciprocating crosshead k^1 , which is located on a vertical bar l^1 , sliding in guides in the frame A, and is reciprocated vertically by a cam m^1 , on the shaft E, a rod n^1 connected to the said cam and a rocking shaft o^1 journaled in the frame A and provided with arms o^2o^3 connected respectively with the rod n^1 and the bar l^1 . The rotation of the shaft E rocks the rocking shaft o^1 , and the latter reciprocates the bar l^1 , and its crosshead vertically, the arms o^3 of the rock shaft being so connected to the bar l^1 that the oscillating motion of the arm will cause a rectilinear motion of the bar. Each of the forwarders F^3 is composed of a pair of separable spring jaws q^1q^2 attached to a suitable reciprocating support, and adapted to move equally like the jaws r^1 . Figure 8 shows a vertical section of one of the forwarders F^3 , in which the jaws q^1q^2 are formed on plates q^3q^4 , which slide on a bar b^3 ; the said plates have openings which receive the ends of a lever q^5 pivoted at q^6 to the bar b^3 , and connected by a spring s^3 to a post on the bar. The bar b^3 is attached to a slide r^1 , which moves in a groove or guide s^1 . This construction causes the jaws q^1q^2 to move simultaneously and equally in opposite directions, so that an object introduced between the jaws will move or displace both jaws equally and be centred or properly placed laterally with reference to the clipping dies. The same construction may be employed in the forwarders F^2 to insure the proper lateral position of the blanks with reference to the nail-forming cavities of the second gang of rolls aa . The forwarders F^1F^2 receive blanks from the last gang of rolling formers, and remove the blanks to the false jaws i^1 , the construction of the jaws q^1q^2 insuring the proper lateral position of the blanks with reference to the punches and dies of the clippers when the blanks are placed in the false jaws i^1i^2 . The forwarders F^1F^2 are reciprocated by means of levers t^1t^2 , connected to the said forwarders by links u^1u^2 , rocking shafts v^1v^2 , rods w^1w^2 , sliding in guides in the frame A and rotating cams x^1x^2 . The rods w^1w^2 are pressed by springs y^1y^2 against the cams x^1x^2 .

During the entire operation of the machine the blank is at no time left to itself, but is continually grasped and held in a predetermined position. The female dies of the punching mechanism with the springs a^3 first hold the blanks after they are separated, and from the said die to the said clippers the blanks are alternately grasped by the forwarders and the formers. This continuous positive control of the blanks ensures the nearest possible approach to perfect uniformity in the nails produced. The rocking or vibrating motion of the rolls aa causes a stoppage or dead point of the rolls when they are in position to receive the blank as shown in fig. 11, and this ensures the entrance of the head of the blank between the dies or cavities bb , and obviates any accident which might occur with continuously rotating rolls, in case the blank were not presented at the exact moment when the dies are ready to receive it.

The spring n which presses the rack against the cam m , and the spring c^1 which presses the bar z against its cam b^1 , also impart a yielding pressure respectively to the forwarders F^1F^2 and F^2F^3 , which pressure impels each of the said forwarders in the direction of the arrow in fig. 2. This yielding pressure produces the following results: 1st. It prevents a shock or jar when the head of the blank is brought in contact with the dies bb , and enables the forwarders F^1F^2 and F^2F^3 (in case they reach the formers to which they deliver the blanks before the said formers are ready to receive them) to press the blank heads against the peripheries of the rolls aa , as shown in fig. 16, until the opening of the dies, and then impel the said heads into the recesses formed by the opening of the dies. 2nd. In case a blank passing through the first former in one series has more material in it than the blank at the same time passing through the corresponding former of the other series, and is therefore made longer by its former, and caused to project farther from the said former before being released, and is detained longer than the period fixed for the forwarders F^2F^3 to move forward, the yielding pressure enables the forwarders F^2F^3 to wait until the longer blank is released, and at the same time to move forward with the longer blank as fast as the latter is moved by its former, so that the forwarders F^2 will not be injured as they would be if they were positively moved before one or both of the blanks is or are released, and the heads of the blanks are kept in line, that is to say, at the same distance from the second gang of formers, so that they are presented simultaneously to the said formers. The springs y^1y^2 impart a similar yielding pressure to the forwarders F^3F^3 , enabling the same to forward the blanks in line to the clippers. By the arrangement of the formers on the ends of their shafts cc , the said formers are exposed, so that any defect in their operation can be readily seen. If desired, one of the rolls a may have a plain surface as shown in fig. 15.

The strip or plate of metal from which the blanks are punched is rolled with its edges thicker than its central portion, the thickened edges forming the enlarged heads of the nails. These heads cause the blanks B^3 to be inclined in the dies GG , as shown in fig. 10. The jaws i^1 of the forwarders F^1 can therefore grasp the blank only at the end head, and hold it in an inclined position as shown in fig. 10a. In order to level the blanks I provide for each forwarder F^1 an inclined surface b^3 attached to the frame of the machine, and arranged to strike the blank while it is moving horizontally, and depress its raised end until it is horizontal, as shown in fig. 10b.

I prefer to interpose a plate a^2 between the springs a^3 and the heads of the blanks in the dies GG , the said plate being pivoted to the dies GG .

It will be seen that the yielding pressure afforded by the springs n c^1 and y^1 does not enable the forwarders $F^1F^2F^3$ to yield or move from the devices which insert the blanks into the jaws of the said forwarders, but the cams m b^1 and x^1x^2 , and the intermediate mechanism described hold or support the forwarders rigidly while they are receiving the blanks. It is obvious that a single series of devices consisting of only one of each of the punching, forming, and forwarding devices shown, will embody the important feature of continuously grasping and progressively moving a nail blank, and will be thus no departure from my invention.

Having

Improvements in Machinery or Apparatus for the manufacture of Horse-shoe Nails.

Having now described and particularly ascertained the nature of the said invention, and the manner in which the same is or may be used or carried into effect, I would observe, in conclusion, that what I consider to be novel and original, and therefore claim as the invention secured to me by the hereinbefore in part recited Letters Patent, is—

- First—In a horse-shoe nail machine, the combination of a punching mechanism, consisting of a reciprocating punch and stationary die, adapted to hold one or more blanks with a forwarder having yielding jaws and mechanism, substantially as set forth, whereby the said forwarder is presented to the die held to receive a blank when the latter is ejected from the die, and then moved to present the blank properly to a succeeding device, as hereinbefore described.
- Second—The combination of punching mechanism, a forwarder having grasping jaws means, substantially as set forth, whereby the forwarder is held to receive a blank emerging from the punching mechanism and then moved to carry the blank forward, and a former arranged and operated to grasp the blank and remove it from the forwarder, as hereinbefore described.
- Third—In a horse-shoe nail machine, the combination of a former consisting of a pair of rotating or vibrating rolls *aa*, a forwarder having grasping jaws and mechanism, substantially as set forth, whereby the said forwarder is presented to a preceding device held to receive a blank from such device, and moved to present the head of the blank properly to the rolls *aa*, as hereinbefore described.
- Fourth—The combination of two formers, an intermediate forwarder having grasping jaws and mechanism, substantially as set forth, whereby the said forwarder is held to receive a blank emerging from one former and moved to present the said blank to the succeeding former, as hereinbefore described.
- Fifth—In an organized machine for making cold rolled horse-shoe nails, employing as elements a series of devices consisting of punching mechanism to separate a blank from a plate, and formers to successively roll the blank, the combination with the said devices of a series of intermediate forwarders having grasping jaws and mechanism, substantially as set forth, whereby the said forwarders are held to receive the blanks and moved to present the same properly to the succeeding devices, as hereinbefore described.
- Sixth—The combination of duplicate punching mechanism arranged to cut two blanks simultaneously from a plate, two forwarders having grasping jaws, means, substantially as set forth, whereby the said forwarders are held to receive two blanks emerging from the punching mechanism, and to carry forward and distribute the said blanks, and two formers arranged to grasp the two blanks simultaneously and remove them from the forwarders.
- Seventh—The combination of a former consisting of a pair of rolls *aa*, adapted to perform a part of the operation of forming a nail, a forwarder adapted to receive a blank from a preceding device and to present the blank to the former, and means, substantially as set forth, for imparting a yielding pressure to the forwarder, whereby the said forwarder is enabled to yield when its blank comes in contact with the rolls *aa*, as hereinbefore described.
- Eighth—The combination, substantially as set forth, of the following elements, to wit: 1st, a gang of formers operating in unison to form and move forward two or more nail blanks; 2nd, a gang of forwarders operating in unison to receive the nail blanks emerging from the formers and move the said blanks forward; and 3rd, means, substantially as described, for imparting a yielding pressure to the said forwarders, whereby the alignment of the heads of the blanks and their simultaneous forward movement are ensured.
- Ninth—In a horse-shoe nail machine, a pair of journalled rolls *aa*, having coinciding cavities or dies *bb*, and mechanism, substantially as described, to oscillate or vibrate the said rolls and bring them to a point of rest at the moment when the dies are properly opened (whereby the dies are momentarily held to receive the blank before moving to roll the same), combined with a forwarder having grasping jaws and mechanism, substantially as set forth, whereby the said forwarder is presented to a preceding device held to receive a blank from such device, and moved to present the blank to the dies *bb*, as hereinbefore described.
- Tenth—In combination with the punching mechanism and the formers, the forwarders *F¹F²*, the rotary spindles *jj* supporting the said forwarders, and means, substantially as set forth, whereby the said spindles are intermittently rotated and raised and lowered, as hereinbefore described.
- Eleventh—The forwarder having separable spring jaws, and means, substantially as set forth, for equalizing the movements of the said jaws at and for the purpose hereinbefore described.
- Twelfth—In combination with the bed *J* supporting the nail plate and the cam *S* journalled in ears on the said bed, the shoe *J¹* pivoted to the bed and adapted to be pressed by the cam against the nail plate, as hereinbefore described.
- Thirteenth—The combination of the clipping mechanism, consisting of the reciprocating punch or shear and stationary bed or die, a forwarder *F³* adapted to move forward and present a blank to the clipping mechanism, and the false jaws *i¹* pivoted to the bed die, and forming a stop to limit the end movement of a blank presented to the clipping mechanism, as hereinbefore described.

In witness whereof, I, the said William Durie, on behalf of the Acme Horse-shoe Nail Company (Limited), have, to this my specification, set my hand and seal, this fourth day of March, one thousand eight hundred and eighty-one.

WM. DURIE,

Secretary, Acme Horse-shoe Nail Company (Limited).

Signed and sealed in the presence of,—

THOS. COOMBER,
Felbridge, East Grinstead, Sussex, Accountant.
A. T. GULLIVAN,
7, Dagmar Road, Camberwell, S.E., Private Secretary.

This is the specification referred to in the annexed Letters of Registration granted to the Acme Horse-shoe Nail Company, this 22nd day of January, A.D. 1884.

AUGUSTUS LOFTUS.

REPORT.

Improvements in Machinery or Apparatus for the manufacture of Horse-shoe Nails.

REPORT.

Sir,

Sydney, 3 May, 1881.

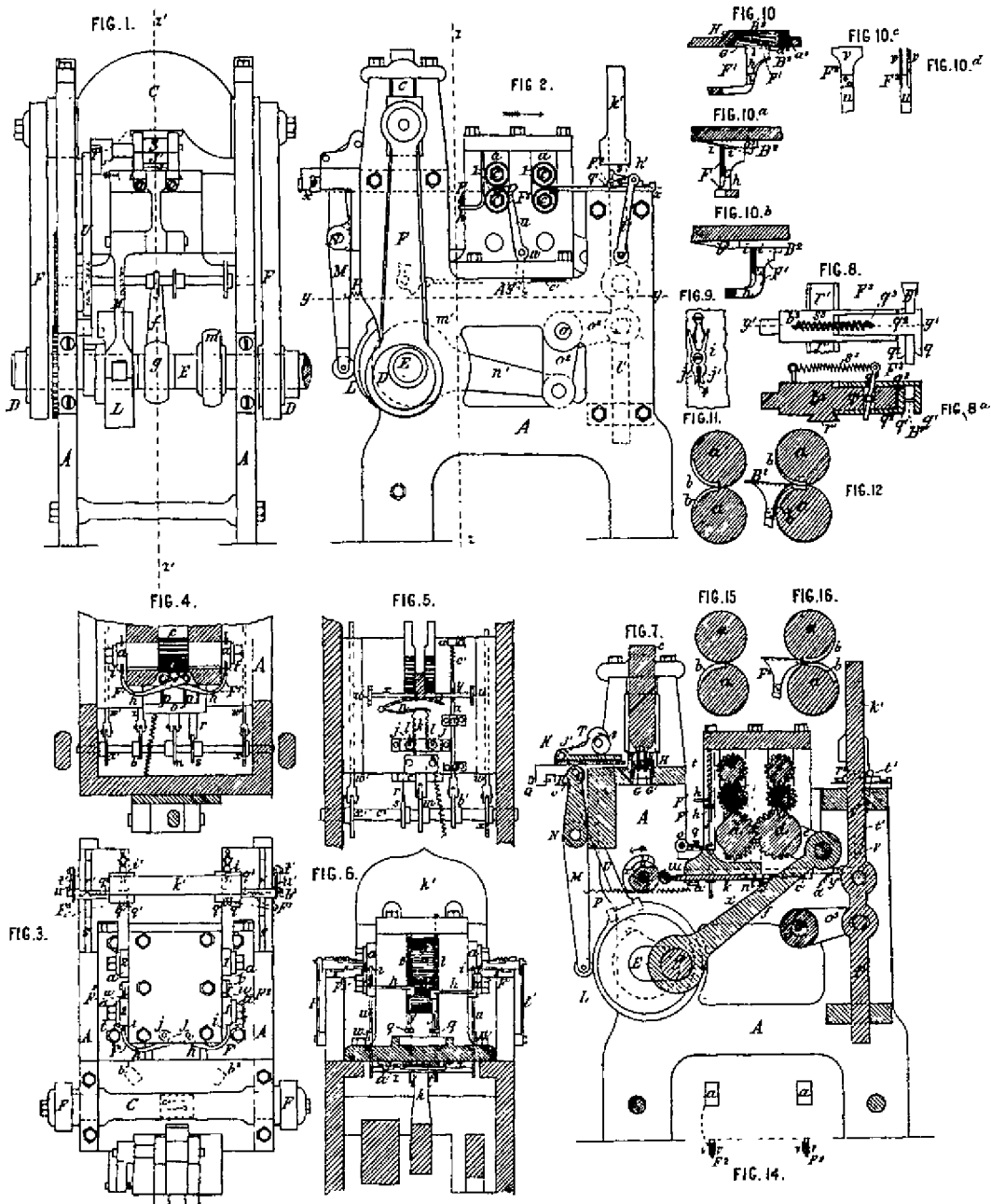
We do ourselves the honor to report, in reply to your blank cover communication of the 26th April, that we are of opinion that the prayer of the Petition of The Acme Horse-shoe Nail Company, for Letters of Registration for an invention entitled, "Improvements in machinery or apparatus for the manufacture of Horse-shoe Nails," may be granted, in accordance with their specification, drawings, and claim.

We have, &c.,

EDMUND FOSBERY.
GOTHEK K. MANN.

The Under Secretary of Justice.

[Drawings—one sheet.]



This is the Sheet of Drawings referred to in the annexed Letters of Registration granted to The Acme Horse Shoe Nail Company, this twenty second day of January, A.D., 1884.

Augustus Loftus.

(Sig. 245.-)



A.D. 1884, 22nd January. No. 1374.

PROCESS FOR SEPARATING WOOL FROM SHEEPSKINS IN THE FRESH STATE.

LETTERS OF REGISTRATION to Paul Henri Picard Goulet, *fls*, for a new or improved process for separating Wool from Sheepskins in the fresh state.

[Registered on the 23rd day of January, 1884, in pursuance of the Act 16 Vic. No. 24.]

BY HIS EXCELLENCY THE RIGHT HONORABLE SIR AUGUSTUS WILLIAM FREDERICK SPENCER LOFTUS (commonly called LORD AUGUSTUS LOFTUS), Knight Grand Cross of the Most Honorable Order of the Bath, a Member of Her Majesty's Most Honorable Privy Council, Governor and Commander-in-Chief of the Colony of New South Wales and its Dependencies.

TO ALL TO WHOM THESE PRESENTS SHALL COME, greeting :

WHEREAS PAUL HENRI PICARD GOULET, *fls*, of Paris, in the Republic of France, hath, by his Petition, humbly represented to me that he is the author or designer of a certain invention or improvement in manufactures, that is to say, of an invention entitled "A new or improved process for separating Wool from Sheepskins in the fresh state," which is more particularly described in the specification which is hereunto annexed ; and that he, the said Petitioner, hath deposited with the Honorable the Treasurer of the said Colony of New South Wales the sum of Twenty Pounds sterling, for defraying the expense of granting these Letters of Registration, as required by the Act of Council, sixteenth Victoria, number twenty-four ; and hath humbly prayed that I would be pleased to grant Letters of Registration, whereby the exclusive enjoyment and advantage of the said invention or improvement might be secured to him for a period of fourteen years : And I, being willing to give encouragement to all inventions and improvements in the arts or manufactures which may be for the public good, and having received a report favourable to the prayer of the said Petition from competent persons appointed by me to examine and consider the matters stated therein, and to report thereon for my information, am pleased, with the advice of the Executive Council, and in exercise of the power and authority given to me by the said Act of Council, to grant, and do by these Letters of Registration grant unto the said Paul Henri Picard Goulet, *fls*, his executors, administrators, and assigns, the exclusive enjoyment and advantage of the said invention or improvement, for and during the term of fourteen years from the date hereof ; to have, hold, and exercise unto the said Paul Henri Picard Goulet, *fls*, his executors, administrators, and assigns, the exclusive enjoyment and advantage thereof, for and during and unto the full end and term of fourteen years from the date of these presents next and immediately ensuing, and fully to be complete and ended : Provided always, that if the said Paul Henri Picard Goulet, *fls*, shall not within three days after the granting of these Letters of Registration, register the same in the proper office in the Supreme Court at Sydney, in the said Colony of New South Wales, then these Letters of Registration, and all advantages whatsoever hereby granted, shall cease and become void.

In witness whereof, I have hereunto set my sign manual, and have caused the present Letters of Registration to be sealed with the seal of the said Colony of New South Wales, at Government House, Sydney, in New South Wales, this 22nd day of January, in the year of our Lord one thousand eight hundred and eighty-four.

[L.S.]

AUGUSTUS LOFTUS.

Process for separating Wool from Sheepskins in the fresh state.

SPECIFICATION of PAUL HENRI PICARD GOULET, *fils*, of Paris, in the Republic of France, for an invention entitled, "A new or improved process for separating Wool from Sheepskins in the fresh state."

THIS invention relates to the separation of wool from sheepskins in the fresh state, that is to say, as they are found immediately or shortly after the skinning of the sheep, without the necessity of drying them or submitting them to any operation whatever, either on the woolly or fleshy side.

My process is exceedingly simple, and is carried out in the following manner :—

First.—The skins freshly removed from the animals are hung just as they are, without previous preparation, in a well-closed chamber, to beams or joints placed at distances from one another, according to the width of the skins to be peeled, and furnished with tenter hooks for receiving the same, the said tenter hooks being spaced according to the thickness of the skins. The skins are well stretched in every direction, and are prevented as far as possible from touching each other or the ground.

Second.—When the chamber is wholly or partially full of suspended and stretched skins, wholly (or nearly so) out of contact with each other, the door is closed hermetically for a few hours in summer, or until the next day in winter, the duration of the operation depending on the temperature of the chamber.

Third.—When the necessary time has elapsed the wool becomes detached of itself, and it is only necessary to remove it by the usual known means and tools. The skin is thus unhaired, and the wool entirely detached from it.

The wool thus separated from the skin can be packed immediately, or it may be combed or washed without any other treatment; the skin is then tanned or tawed on the spot, or exported after having been air dried, or simply salted.

The phenomenon of the natural separation of the wool from the skins suspended in the hermetically-closed chamber is easily explained.

The fresh skins being introduced into a closed chamber, as soon as possible after they have been removed from the animal, and this chamber being full, or nearly so, of these skins, hung near one another, it follows that in a few moments there is disengaged from the skins, which are so to speak still warm, a soft natural heat arising from that produced by the grease of the wool. This heat effects a fermentation which forces the skin to perspire to a certain extent; the pores then open, and at that moment the wool is detached from the skin with the greatest ease.

The wool obtained by this process is admirable. It is dry, ready for packing, or immediate use. It has not suffered from contact with any ingredient, either hot or cold, and is worth as much as, and even more than, the shorn wool. In fact, at equal maturity, my natural wool is longer than shorn wool, because it has been removed with the whole of its root, whilst shorn wool is mutilated by the shears. This operation of shearing cuts the tube of the wool, and the white grease contained therein, which constitutes its nature and elasticity, is partly lost. My system, on the contrary, preserves this white grease, since the tube which contains it remains closed. It may therefore be concluded that my wool, which is absolutely natural, preserves all the essential qualities for combing and spinning, which shorn wool has not, and never can have.

The sorting is also more easily effected, for by placing the skins on the tables or benches where they are to be stripped the workmen can easily separate the parts which are superior, as regards fineness and nature, from the inferior, base, dirty, or defective parts. This operation is completely impracticable when the wool is shorn on the back of the sheep.

If the advantages of my process are remarkably great as regards the wool, they are not less so as regards the skins, for the latter have not suffered from the use of any acid whatever; they have preserved all their elasticity and strength, and, above all, they can be dried or salted for exportation under the best conditions.

To enable the importance of my invention to be appreciated and compared with the other systems used heretofore, I shall describe the usual way of treating sheepskins.

Fresh skins are taken, as in my case; over the fleshy side is passed either a depilatory substance, or, more frequently, a quantity of lime, or arsenic orpiment, or sulphuret of potassium; but all these substances or drugs are hurtful or corrosive, not only for the skin, but also for the wool, which latter is powerfully attacked thereby at the roots. The wool thus loses much of its value, and is sensibly less appreciated than shorn wool.

As regards the skins, the use of these various chemical processes has perhaps smaller objections; but it is indispensable that they should be tawed on the spot, as the acids which have hardened and affected them do not allow of drying or salting them for exportation.

In comparing my new process with the old systems the results are: First, that by my process I am able to effect the removal of the wool from fresh skins without the necessity of touching them, that is to say, without any operation either upon the skin or the wool, whereby complete preservation of all the natural and primitive qualities of the wool is effected. Second, as regards the skins—not only are they superior when immediately tawed after peeling, as in the other systems, but they offer the immense advantage that they can be exported either dry or salted.

By the systems heretofore used not only are the depilatory substances costly, and the manner of operating lengthy, but they notably depreciate the wool known in commerce by the name of "tawing wool" (*laine de mégisserie*) or low-priced inferior wool. This tawing wool has the grave objection of not taking dye, or of taking it badly.

In short, the advantages of my process of separation of wool from the skins in the fresh state will radically transform the industry relating to the treatment of sheepskins.

Having

Process for separating Wool from Sheepskins in the fresh state.

Having now described the nature of the said invention, and the manner in which the same is to be carried into effect, I would have it understood that what I claim is—

The new or improved process for separating wool from sheepskins, which process consists in separating the wool from sheepskins, which are preferably as fresh as possible, without any previous treatment or preparation, either on the wool or fleshy side, by arranging the said skins in any suitable manner, in a more or less perfectly closed chamber or place, as hereinbefore described.

In witness whereof, I, the said Paul Henri Picard Goulet, *file*, have hereunto set my hand and seal, at Paris, this thirtieth day of August, in the year of our Lord one thousand eight hundred and eighty-three.

PAUL HENRI PICARD GOULET, *FILE*.

Signed, sealed, and delivered by the abovenamed

Paul Henri Picard Goulet, *file*, in the presence of—HENRY WILLOUGHBY,
British Vice-Consul at Paris.

This is the specification referred to in the annexed Letters of Registration granted to Paul Henri Picard Goulet, *file*, this 22nd day of January, A.D. 1884.

AUGUSTUS LOFTUS.

REPORT.

Sir,

We do ourselves the honor to report, in reply to your blank cover, 15th instant, No. 13,754., that we are of opinion the prayer of Paul Henri Picard Goulet, *file*, Petition for the Registration of "A new and improved process for separating Wool from Sheepskins in the fresh state," may be granted, in terms of his specification and claim.

Sydney, 23 November, 1883.
We have, &c.,

GOTHER K. MANN.
EDMUND FOSBERY.

The Under Secretary of Justice.



A.D. 1884, 22nd January. No. 1375.

IMPROVEMENTS IN ENTRAPPING WILD ANIMALS.

LETTERS OF REGISTRATION to Abraham Batterham, for Improvements in the method of and apparatus for Entrapping Wild Animals.

[Registered on the 23rd day of January, 1884, in pursuance of the Act 16 Vic. No. 24.]

BY HIS EXCELLENCY THE RIGHT HONORABLE SIR AUGUSTUS WILLIAM FREDERICK SPENCER LOFTUS (commonly called LORD AUGUSTUS LOFTUS), Knight Grand Cross of the Most Honorable Order of the Bath, a Member of Her Majesty's Most Honorable Privy Council, Governor and Commander-in-Chief of the Colony of New South Wales and its Dependencies.

TO ALL TO WHOM THESE PRESENTS SHALL COME, greeting:

WHEREAS ABRAHAM BATTERHAM, of Timor, near Blandford, in the Colony of New South Wales, farmer, hath by his Petition humbly represented to me that he is the author or designer of a certain invention or improvement in manufactures, that is to say, of an invention entitled "Improvements in the method of and apparatus for Entrapping certain Wild Animals," which is more particularly described in the specification and the sheet of drawings which are herewith annexed; and that he, the said Petitioner, hath deposited with the Honorable the Treasurer of the said Colony of New South Wales the sum of Twenty Pounds sterling, for defraying the expense of granting these Letters of Registration, as required by the Act of Council, sixteenth Victoria, number twenty-four; and hath humbly prayed that I would be pleased to grant Letters of Registration whereby the exclusive enjoyment and advantage of the said invention or improvement might be secured to him for a period of fourteen years: And I, being willing to give encouragement to all inventions and improvements in the arts or manufactures which may be for the public good, and having received a report favourable to the prayer of the said Petition from competent persons appointed by me to examine and consider the matters stated therein and to report thereon for my information, am pleased, with the advice of the Executive Council, and in exercise of the power and authority given to me by the said Act of Council, to grant, and do by these Letters of Registration grant unto the said Abraham Batterham, his executors, administrators, and assigns, the exclusive enjoyment and advantage of the said invention or improvement for and during the term of fourteen years from the date hereof; to have, hold, and exercise unto the said Abraham Batterham, his executors, administrators, and assigns, the exclusive enjoyment and advantage thereof, for and during and unto the full end and term of fourteen years from the date of these presents next and immediately ensuing, and fully to be complete and ended: Provided always, that if the said Abraham Batterham shall not, within three days after the granting of these Letters of Registration, register the same in the proper office in the Supreme Court, at Sydney, in the said Colony of New South Wales, then these Letters of Registration, and all advantages whatsoever hereby granted, shall cease and become void.

In witness whereof, I have hereunto set my sign manual, and have caused the present Letters of Registration to be sealed with the seal of the said Colony of New South Wales, at Government House, Sydney, in New South Wales, this twenty-second day of January, in the year of our Lord one thousand eight hundred and eighty-four.

[L.S.]

AUGUSTUS LOFTUS.

Improvements in Entrapping Wild Animals, &c.

SPECIFICATION of ABRAHAM BATTERHAM, farmer, of Timor, near Blandford, in the Colony of New South Wales, farmer, for an invention entitled "Improvements in the method of and apparatus for Entrapping certain Wild Animals."

To entrap wild animals such as kangaroos, wallabys, horses, cattle, dogs, rabbits, opossums, rats, and the like, it has been customary to catch or snare them one by one in a small trap, or to entrap them in small numbers, but it has been found practically impossible to make any appreciable difference in the number of such animals at large by any such means, as said animals are naturally cunning, and soon learn to know and avoid the trap and the place of operation. With the above in view, I have sought to devise a method by which large numbers of said animals may be entrapped in an enclosure wherein they may be caught or killed.

According to my method, I first allow the animals in considerable numbers to freely pass into and assemble upon a tempting feeding enclosure for some little time, said enclosure being bounded by a fence proof against the passage of the animals desired to be entrapped. I gradually diminish the number of openings through said fence so as not to alarm the animals which make the enclosure their regular feeding-ground. When I have only (say) two openings through the fence, one of which being through the frame of my gate or trapping contrivance, and I then gradually and at intervals bring the trap into working position so that the animals will become used to passing through it; and I ultimately close all openings but that through the trap or gate which is now set, so that the animals may freely enter the enclosure, but cannot pass out again.

My improved apparatus or gate consists of a set of hinged sharp-pointed prongs or spikes, which is held open the required distance by a spring or other elastic medium so that it will freely move backwards by pressure from without, and will close by pressure from within, *i.e.*, when the trap is set the prongs are so inclined that they will stick into the body of an animal should such animal attempt to force its way through from the inside.

But in order that my invention may be clearly understood, I will now describe the same with reference to the drawings hereto attached, in which figure 1 is a back view, figure 2 a side elevation, and figure 3 a plan respectively of my improved apparatus or trap. Figure 4 is an elevation of a gate on which my sharp-pointed prongs are fixed for the same purpose; and figure 5 is a plan of figure 4. Figure 6 is a plan of the enclosures in which I prefer to entrap the animals.

Referring to figures 1, 2, and 3, A is a set of prongs, B a hinged door or grid, C C springs, D the skeleton frame, and E a fence post; A¹ is an adjustable support at either side, and A² an adjustable stop thereon; B¹B¹ are hinges, B² pin; C¹C¹ are regulating stops for these springs; D¹ are curved guides for pins B² of door or grid, D² extension of frame for rod D².

In this case the trap is gradually set by lowering rod D² from one hole to another in extension D², and ultimately taking said rod away, when the door or grid B carrying the set of prongs A will rest by means of pins B¹ on springs C. The prongs are set at the required angle by raising or lowering support A¹ by means of the double nuts, or by bolting said support in a different hole B¹. To the set of prongs such backward or upward motion as desired is allowed by inserting stop A² in one or other of the various holes in support A¹. Now, an animal may freely enter through this gate or trap in its passage, slightly lifting the set of prongs A as far as stops A² allow, and then, if necessary, the door or grid on its hinges B¹, said door and prongs returning to their normal position by their own weight after the animal has passed through. Should the animal seek to return its body will come in contact with the sharp points of the prongs, and if it persevere will move them and the grid (upon hinges B¹) against the pressure of springs C¹ to the bottom of the trap, and thus close the passages. By means of stops C¹ springs C are bent down, and allow the door or grid with its prongs to take, normally, a lower position, bringing the points of the prongs closer to the ground, and thus making the trap or gate suitable for smaller animals.

Referring to figures 4 and 5, the sets of prongs A by means of adjustable supports A¹, and stops A² thereon, are fixed to common gate B provided with a spring C. C¹ is a stake driven in the ground. It will be seen that the action of this gate is the same as that of the apparatus before described.

Referring to figure 6, E is (say) a five- to ten-acre paddock, F a half-acre paddock at one end of it, and G a killing-yard (say) sixteen feet square. E¹, F¹, and G¹ are openings through the fence, which fence is proof against the passage of the animals it is desired to entrap, F² and G² are openings which have a gate or door which may be easily and quickly closed preferably from a good distance away. E² is the position of one of my improved gates or traps. The paddock E is preferably one sown with lucerne or other food to which the animals are partial; but where food is scarce I propose to use salt as a means of enticing the animals into the enclosure, and I also propose to take advantage of waterholes when necessary. The trap being in position, openings E¹, F¹, and G¹ are closed one by one at intervals of (say) two or three days or longer, until they are all closed, G¹ being the last one to be closed, and this one is closed on the day on which the trap is finally set, as before described. When the trap has been set long enough, namely, when a considerable number of animals are in the enclosures, the trapper approaches the trap or gate E², and the animals in paddock E having no other exit will make towards opening F² and pass into paddock F, and gate F² being then closed they may be drafted through gate G² into yard G, and there caught or killed.

When trapping animals such as rabbits I would of course make the enclosures much smaller, and would also provide a false bottom (say) of wire or rope-netting; and for opossums and such like I would likewise provide a top to such enclosure.

Having thus particularly described and ascertained my said invention, and the manner in which the same is to be performed, I would have it understood that what I believe to be new, and therefore claim as my improvements in the method of and apparatus for entrapping certain wild animals, is—

- 1st. Gradually diminishing the number of openings into a feeding or other enclosure to one or more, in which are gates or traps which are gradually set into working position so as to allow animals to enter, but prevent their egress, substantially as herein described and explained.
- 2nd. A set of prongs or spikes fixed upon or in a gate or frame in such a way that an animal striving to pass through in the opposite direction to which said prongs point will close said gate or frame, substantially as herein described and explained.
- 3rd.

Improvements in Entrapping Wild Animals, &c.

- 3rd. The combination and arrangement of parts forming my trapping apparatus or gate, substantially as herein described and explained, and as illustrated in figures 1, 2, and 3 of the drawings,
- 4th. The combination and arrangement with a gate or frame B of a set of sharp-pointed prongs A and a spring C, substantially as herein described and explained, and as illustrated in figures 4 and 5 of the drawings.

In witness whereof, I, the said Abraham Batterham, have hereto set my hand and seal, this twenty-sixth day of November, 1883.

ABRAHAM BATTERHAM,
(By his Agent, FRED. WALSH, Manager, E. Waters' Patent Office, Sydney).

This is the specification referred to in the annexed Letters of Registration granted to Abraham Batterham, this twenty-second day of January, A.D. 1884.

AUGUSTUS LOFTUS.

REPORT.

Sir,

Sydney, 3 December, 1883.

The application of Mr. Abraham Batterham for Letters of Registration for an invention entitled "Improvements in the method of and apparatus for Entrapping certain Wild Animals," having been referred to us, we have examined the plan and specification accompanying the same, and have now the honor to report that we see no objection to the issue of Letters of Registration, as applied for.

We have, &c.,

ARCH. FRASER.
THOS. RICHARDS.

The Under Secretary of Justice.

[Drawings—one sheet.]

No. 1376.

[Assignment of No. 1118.]

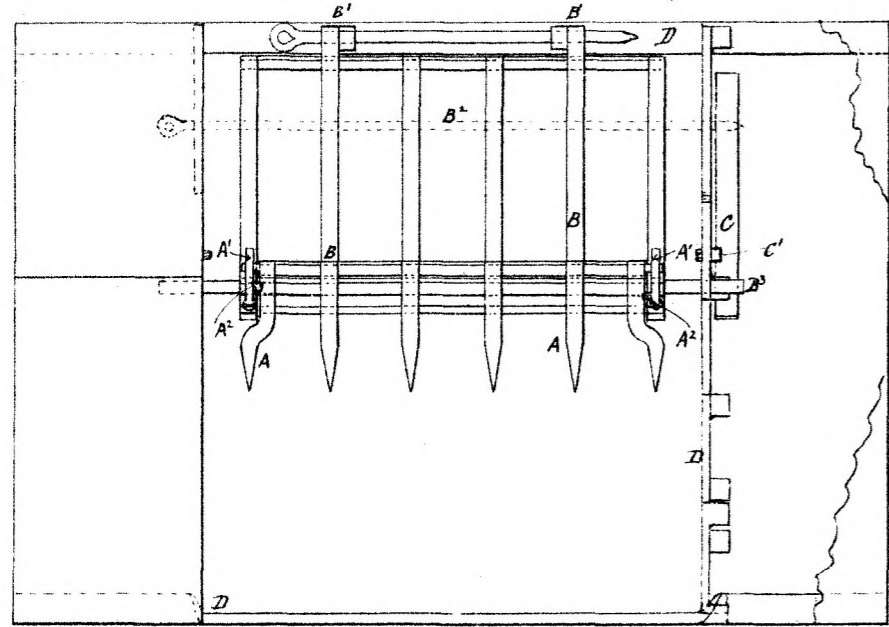


Fig. 1.

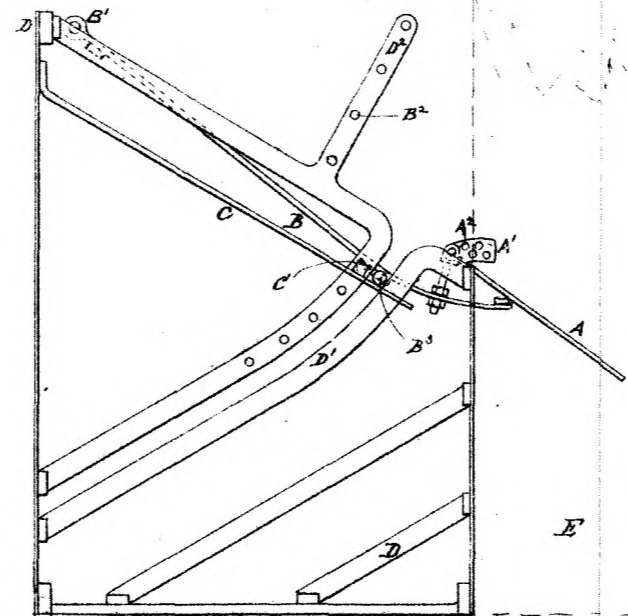


Fig. 2.

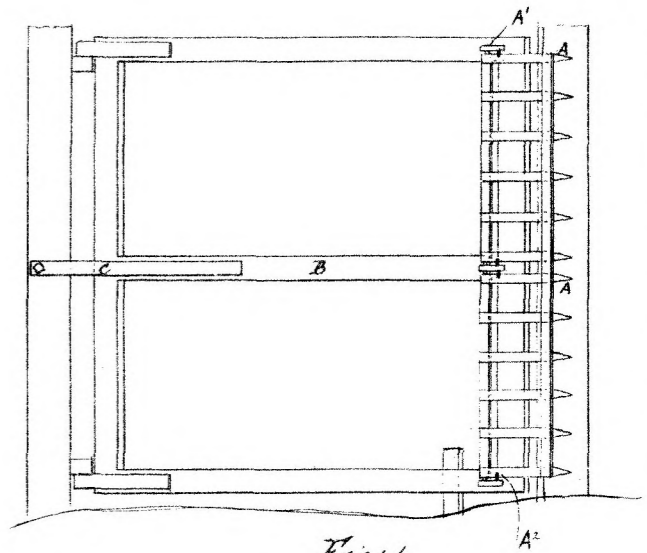


Fig. 4.

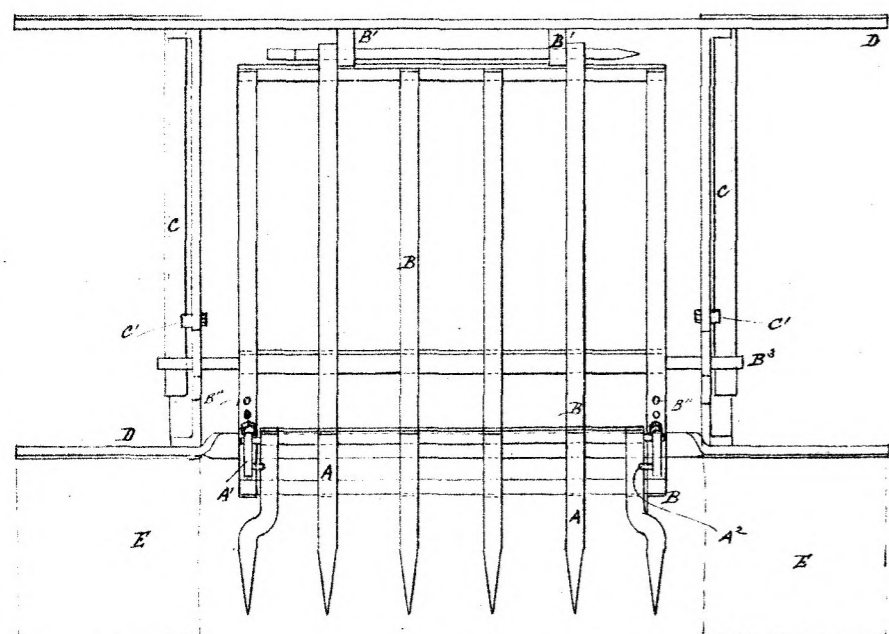


Fig. 3.

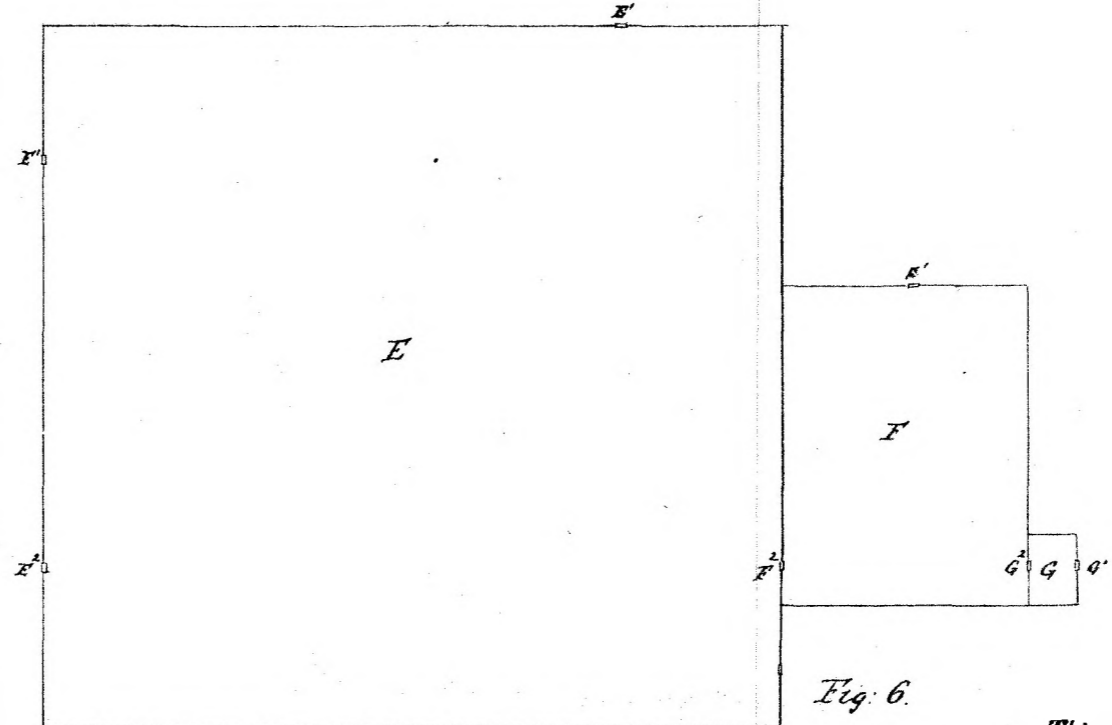


Fig. 6.

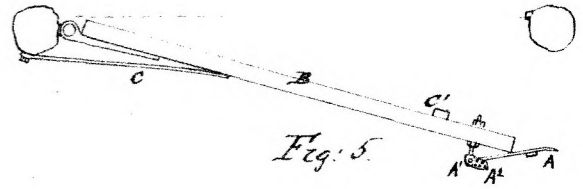


Fig. 5.

This is the Sheet of Drawings referred to in the annexed Letters of Registration, granted to Abraham Butterham, this twenty second day of January, A. D., 1884. Augustus Loftus.



A.D. 1884, 6th February. No. 1377.

AN IMPROVED PORTABLE WIRE STRAINER.

LETTERS OF REGISTRATION to Sydney W. Fulton, for an Improved Portable Wire Strainer."

[Registered on the 7th day of February, 1884, in pursuance of the Act 16 Vic. No. 24.]

BY HIS EXCELLENCY THE RIGHT HONORABLE SIR AUGUSTUS WILLIAM FREDERICK SPENCER LOFTUS (commonly called LORD AUGUSTUS LOFTUS), Knight Grand Cross of the Most Honorable Order of the Bath, a Member of Her Majesty's Most Honorable Privy Council, Governor and Commander-in-Chief of the Colony of New South Wales and its Dependencies.

TO ALL TO WHOM THESE PRESENTS SHALL COME, greeting :

WHEREAS SYDNEY WROUGHTON FULTON, of West Taieri, near Dunedin, in the Colony of New Zealand, farmer, hath by his Petition humbly represented to me that he is the author or designer of a certain invention or improvement in manufactures, that is to say, of an invention entitled "An Improved Portable Wire Strainer," which is more particularly described in the specification and the sheet of drawings which are hereunto annexed ; and that he the said Petitioner hath deposited with the Honorable the Treasurer of the said Colony of New South Wales the sum of Twenty Pounds sterling, for defraying the expense of granting these Letters of Registration, as required by the Act of Council, sixteenth Victoria, number twenty-four ; and hath humbly prayed that I would be pleased to grant Letters of Registration, whereby the exclusive enjoyment and advantage of the said invention or improvement might be secured to him for a period of fourteen years : And I, being willing to give encouragement to all inventions and improvements in the arts or manufactures which may be for the public good, and having received a report favourable to the prayer of the said Petition, from competent persons appointed by me to examine and consider the matters stated therein and to report thereon for my information, am pleased, with the advice of the Executive Council, and in exercise of the power and authority given to me by the said Act of Council, to grant, and do by these Letters of Registration grant unto the said Sydney Wroughton Fulton, his executors, administrators, and assigns, the exclusive enjoyment and advantage of the said invention or improvement, for and during the term of fourteen years from the date hereof ; to have, hold, and exercise unto the said Sydney Wroughton Fulton, his executors, administrators, and assigns, the exclusive enjoyment and advantage thereof, for and during and unto the full end and term of fourteen years from the date of these presents next and immediately ensuing, and fully to be complete and ended : Provided always, that if the said Sydney Wroughton Fulton shall not, within three days after the granting of these Letters of Registration, register the same in the proper office in the Supreme Court, at Sydney, in the said Colony of New South Wales, then these Letters of Registration, and all advantages whatsoever hereby granted, shall cease and become void.

In witness whereof, I have hereunto set my sign manual, and have caused the present Letters of Registration to be sealed with the seal of the said Colony of New South Wales, at Government House, Sydney, in New South Wales, this sixth day of February, in the year of our Lord one thousand eight hundred and eighty-four.

[L.S.]

AUGUSTUS LOFTUS.

An Improved Portable Wire Strainer.

SPECIFICATION of SYDNEY WROUGHTON FULTON, of West Taieri, near Dunedin, in the Colony of New Zealand, farmer, for an Invention entitled "An Improved Portable Wire Strainer."

THIS invention consists of an improved portable wire strainer, the marked peculiarity of which is that it grips the wire between the posts, which wire is then cut, and the machine then takes up the slack, after which the cut ends are rejoined. Many parts of my machine are not new in themselves, but are new in their combination and arrangement with the other parts of my strainer; whilst the machine, as a whole, is substantially different in its operation to any other of a similar character yet produced. Other machines take up the slack from one end of the wire. I take it from any point between the ends. Other machines take their strain from the end post. I take it not from a post at all, but from a grip on the wire. In order, however, that my invention may be clearly understood I will now refer to the drawings hereto attached, on which the nature of the several figures is written. From them it will be seen that my strainer consists of an iron ring or framing 1, split at A and having cheeks fixed thereon as shown for the reception of a small windlass 2, in which there is a small hole 9, a ratchet 3, fastened to the windlass 2, a spring pawl 4, a cam grip 5 and 6, another cam 7, working against a revolving stud 8, and a handle 10 for turning the windlass. I also use two small keys 11 for tying or twisting the wire when strained. The method of using the strainer in erecting new fencing is as follows, that is to say:—I first fasten the wires to the posts at each end of the line required to be strained and draw the wires as tight as possible with the hands. I then go to the centre of the strain, cut the wire to be strained, catch one end in the grip, 5 and 6, say about eight inches from the end, pass the other end between grip 7 and 8, and through the small hole 9 in windlass, to which it is temporarily fastened. This done, I bring up the slack wire by turning handle 10 until the wire is tight enough. When this result is attained, I press cam 7 against stud 8 with one hand, and with the other I release spring pawl 4 and unwind the windlass and loosen the wire. This being now held in the two grips, between 5 and 6 and between 7 and 8, I loop the two loose parts of the wire together, bringing the two ends round and tying or twisting them by means of the two small keys 11 (as is well understood); the straining of the wire is then completed, and the machine is removed. It will be found more convenient as a rule to cut the surplus wire off before tying. In straining the wire of old fences the machine is used in exactly the same way as in straining the wire of new fences. The framing 1 is not necessarily ring shaped; it may be of any suitable shape and size.

Having thus described the nature of my invention, and the manner of performing the same, I would have it understood that I am aware that wire-straining machines have been used in which grippers grip the wire, a windlass takes up the slack, and a pawl and ratchet prevent the back revolution of the windlass. I therefore do not claim the exclusive use of these contrivances *per se*, but what I believe to be new, and therefore claim, is—

The specific arrangement and combination of the gripping and winding contrivances with the framing of my machine, substantially as and for the purposes herein described and explained.

In witness whereof, I, the said Sydney Wroughton Fulton, have hereto set my hand and seal, this twentieth day of November, one thousand eight hundred and eighty-three.

SYDNEY W. FULTON.

Witness—

A. RATHFORTH,
Solicitor, Dunedin, N.Z.

This is the specification referred to in the annexed Letters of Registration granted to Sydney Wroughton Fulton, the sixth day of February, A.D. 1884.

AUGUSTUS LOFTUS.

REPORT.

Sir,

We do ourselves the honor to report, in reply to your blank cover, 4th instant, No. 14,271, transmitting the Petition of Sydney Wroughton Fulton for the registration of "An Improved Portable Wire Strainer," that we are of opinion the prayer of the Petitioner may be granted in terms of his specification, drawing, and claim.

We have, &c.,

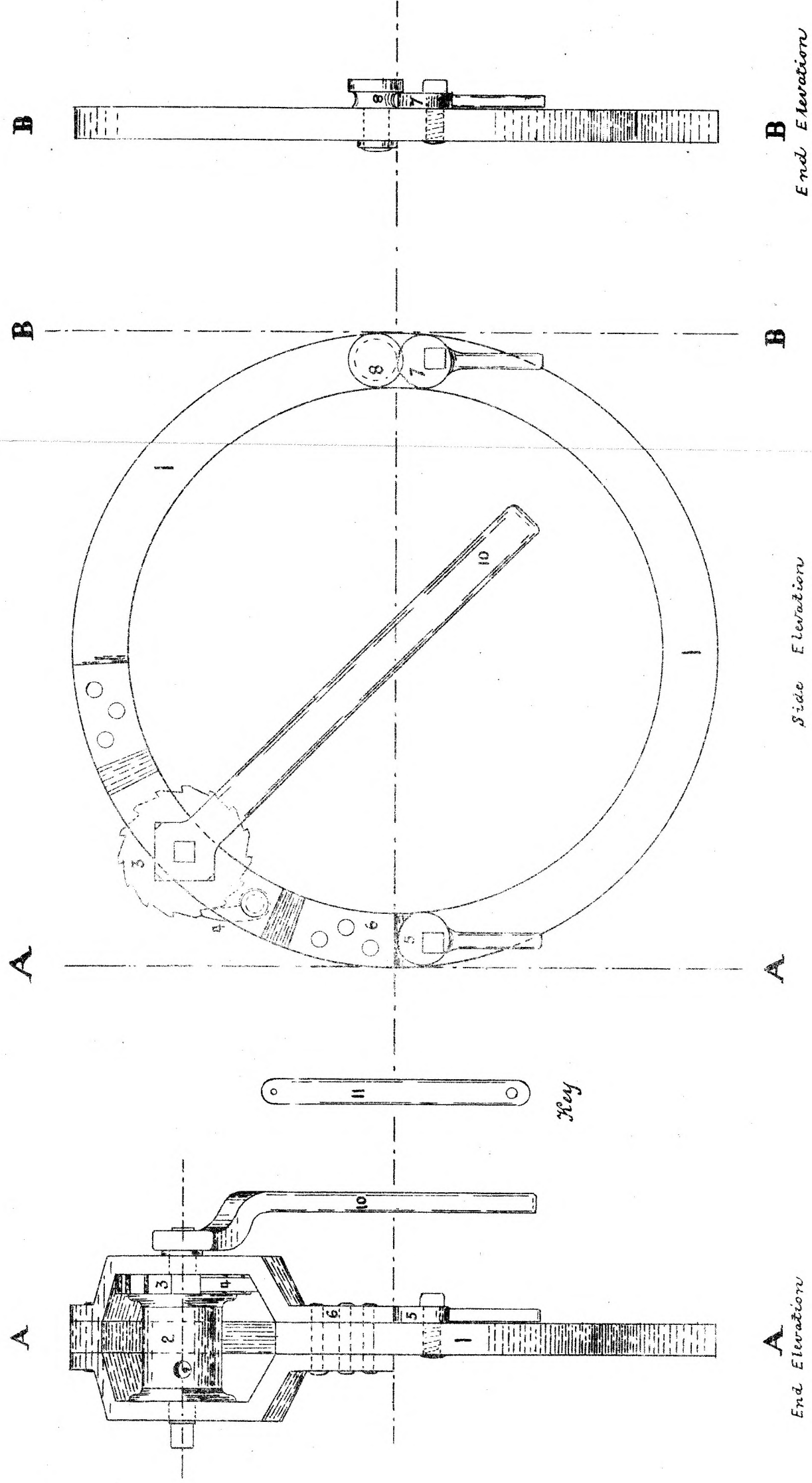
E. C. CRACKNELL,
GOTHER K. MANN.

The Under Secretary of Justice.

[Drawings—one sheet.]

IMPROVED PORTABLE WIRE STRAINER

Scale 1/2 natural size



This is the Sheet of Drawings referred to in the annexed Letters of Registration, granted to Sydney Wroughton Filton, the sixth day of February, A.D., 1884.
Augustus Loftus.



A.D. 1884, 6th February. No. 1378.

IMPROVED SPRING FOR VEHICLES.

LETTERS OF REGISTRATION to Henry Timken, for an Improved Spring for Vehicles.

[Registered on the 7th day of February, 1884, in pursuance of the Act 16 Vic. No. 24.]

BY HIS EXCELLENCY THE RIGHT HONORABLE SIR AUGUSTUS WILLIAM FREDERICK SPENCER LOFTUS (commonly called LORD AUGUSTUS LOFTUS), Knight Grand Cross of the Most Honorable Order of the Bath, a Member of Her Majesty's Most Honorable Privy Council, Governor and Commander-in-Chief of the Colony of New South Wales and its Dependencies.

TO ALL TO WHOM THESE PRESENTS SHALL COME, greeting :

WHEREAS HENRY TIMKEN, of Saint Louis, in the State of Missouri, one of the United States of America, hath by his petition humbly represented to me that he is the author or designer of a certain invention or improvement in manufactures, that is to say, of an invention entitled "An Improved Spring for Vehicles," which is more particularly described in the specification and the sheet of drawings which are hereunto annexed; and that he, the said Petitioner, hath deposited with the Honorable the Treasurer of the said Colony of New South Wales the sum of Twenty Pounds sterling, for defraying the expense of granting these Letters of Registration, as required by the Act of Council, sixteenth Victoria, number twenty-four; and hath humbly prayed that I would be pleased to grant Letters of Registration, whereby the exclusive enjoyment and advantage of the said invention or improvement might be secured to him for a period of fourteen years: And I, being willing to give encouragement to all inventions and improvements in the arts or manufactures which may be for the public good, and having received a report favourable to the prayer of the said Petition, from competent persons appointed by me to examine and consider the matters stated therein and to report thereon for my information, am pleased, with the advice of the Executive Council, and in exercise of the power and authority given to me by the said Act of Council, to grant, and do by these Letters of Registration grant unto the said Henry Timken, his executors, administrators, and assigns, the exclusive enjoyment and advantage of the said invention or improvement, for and during the term of fourteen years from the date hereof; to have, hold, and exercise unto the said Henry Timken, his executors, administrators, and assigns, the exclusive enjoyment and advantage thereof, for and during and unto the full end and term of fourteen years from the date of these presents next and immediately ensuing, and fully to be complete and ended: Provided always, that if the said Henry Timken shall not, within three days after the granting of these Letters of Registration, register the same in the proper office in the Supreme Court, at Sydney, in the said Colony of New South Wales, then these Letters of Registration, and all advantages whatsoever hereby granted, shall cease and become void.

In witness whereof, I have hereunto set my sign manual, and have caused the present Letters of Registration to be sealed with the seal of the said Colony of New South Wales, at Government House, Sydney, in New South Wales, this sixth day of February, in the year of our Lord one thousand eight hundred and eighty-four.

[I.S.]

AUGUSTUS LOFTUS.

Improved Spring for Vehicles.

SPECIFICATION of HENRY TIMKEN, of St. Louis, in the State of Missouri, one of the United States of America, for an invention entitled "An Improved Spring for Vehicles."

THIS invention relates to those kinds of springs for buggies, carriages, and other vehicles which form an elliptical arch or an approximation thereto. These are formed ordinarily of a succession of leaves or plates placed one on the top of the other, and bolted together, the lower plate or main leaf reaching from one extremity of the spring to the other, and having eyes formed at its ends for attachment to the vehicle, the centre or slackest portion of the spring being fixed to the axle or to its desired position by clips or otherwise. Now, my invention consists in making such springs in two halves, which together form an elliptical arch, the crown of which is at the point where one half intersects the other half, and in bolting said halves to a wooden plate on which the body of vehicle rests, and to which it also is bolted. This method of construction is clearly illustrated in my drawing, in which figure 1 shows side view of one of my springs, and figure 2 view of buggy frame turned upside down, to which two of my springs are attached. A and B are the two halves of the spring, each composed of leaves or plates superimposed one upon the other, as is the custom now, and each half bolted to the one wooden plate C. In each case the upper plate is made (not necessarily but preferably) so as to project beyond the wooden plate, and two short metal straps D are also bolted to the underside of each of these wooden plates for the purpose of equalizing any strain over the whole of said plate when it is attached to or supporting the vehicle. EE are the side bars of the framing to which the outer ends of the springs are attached by clips in the ordinary way.

Having thus described the nature of my invention and the manner of performing same, I would have it understood that what I claim is—

First—The construction of elliptical arched springs for buggies, carriages, and other vehicles in two halves, as herein described and explained, and as illustrated in my drawings.

Second—The combination of such springs with wooden plates for supporting the buggy, carriage, or other vehicle, also substantially, as herein described and explained, and as illustrated in my drawings.

In witness whereof, I, the said Henry Timken, have hereto set my hand and seal, this twenty-ninth day of November, one thousand eight hundred and eighty-three.

HENRY TIMKEN,
(By his Agent, EDWD. WATERS).

Witness—

W. S. BAYSTON,
Patent Law Clerk, Melbourne.

This is the specification referred to in the annexed Letters of Registration granted to Henry Timken, the 6th day of February, A.D. 1884.

AUGUSTUS LOFTUS.

REPORT.

Sir,
The application of Mr. Henry Timken for Letters of Registration for "An Improved Spring for Vehicles," having been referred to us, we have examined the specification and drawings accompanying the same, and have now the honor to report that we see no objection to the issue of Letters of Registration as prayed of.

We have, &c.,

JAMES BARNET.
WILLIAM C. BENNETT.

The Under Secretary of Justice.

[Drawings—one sheet.]

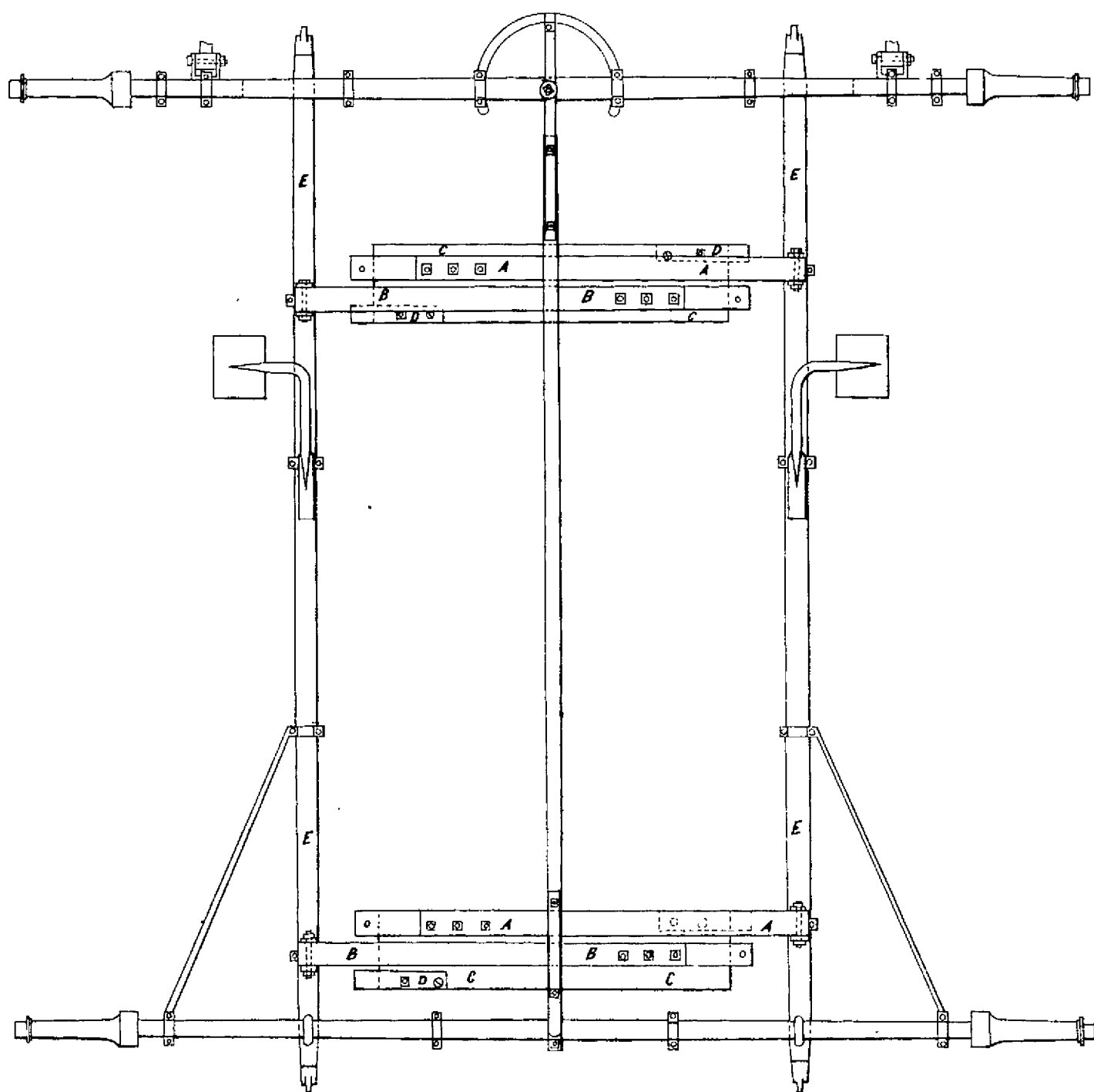


Fig. 2.

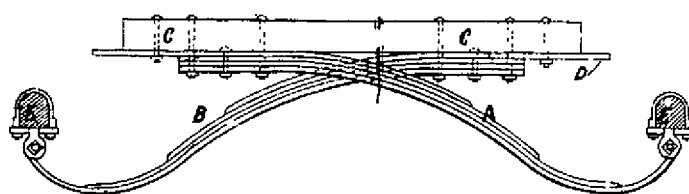


Fig. 1.

*This is the Sheet of Drawings referred to in the annexed Letters
of Registration granted to Henry Timken the sixth day of
February A D 1884*

Augustus Loftus

(Sig: 245-)



A.D. 1884, 6th February. No. 1379.

IMPROVEMENTS IN COUPLINGS FOR TRAM AND RAILWAY ROLLING STOCK.

LETTERS OF REGISTRATION to John Brown, for Improvements in Couplings for Tram and Railway Rolling Stock.

[Registered the 7th day of February, 1884, in pursuance of the Act 16 Vic. No 24.]

BY HIS EXCELLENCY THE RIGHT HONORABLE SIR AUGUSTUS WILLIAM FREDERICK SPENCER LOFTUS (commonly called LORD AUGUSTUS LOFTUS), Knight Grand Cross of the Most Honorable Order of the Bath, a Member of Her Majesty's Most Honorable Privy Council, Governor and Commander-in-Chief of the Colony of New South Wales and its Dependencies.

TO ALL TO WHOM THESE PRESENTS SHALL COME, greeting :

WHEREAS JOHN BROWN, of No 42, Burnett-street, Redfern, near Sydney, in the Colony of New South Wales, engineer, hath by his Petition humbly represented to me that he is the author or designer of a certain invention or improvement in manufactures, that is to say, of an invention entitled "Improvements in Couplings for Tram and Railway Rolling Stock," which is more particularly described in the specification, marked A, and the two sheets of drawings, marked B and C respectively, which are hereunto annexed; and that he, the said Petitioner, hath deposited with the Honorable the Treasurer of the said Colony of New South Wales the sum of Twenty Pounds sterling, for defraying the expense of granting these Letters of Registration, as required by the Act of Council, sixteenth Victoria, number twenty-four; and hath humbly prayed that I would be pleased to grant Letters of Registration, whereby the exclusive enjoyment and advantage of the said invention or improvement might be secured to him for a period of fourteen years: And I, being willing to give encouragement to all inventions and improvements in the arts or manufactures which may be for the public good, and having received a report favourable to the prayer of the said Petition, from competent persons appointed by me to examine and consider the matters stated therein and to report thereon for my information, am pleased, with the advice of the Executive Council, and in exercise of the power and authority given to me by the said Act of Council, to grant, and do by these Letters of Registration grant unto the said John Brown, his executors, administrators, and assigns, the exclusive enjoyment and advantage of the said invention or improvement, for and during the term of fourteen years from the date hereof; to have, hold, and exercise unto the said John Brown, his executors, administrators, and assigns, the exclusive enjoyment and advantage thereof, for and during and unto the full end and term of fourteen years from the date of these presents next and immediately ensuing, and fully to be complete and ended: Provided always, that if the said John Brown shall not, within three days after the granting of these Letters of Registration, register the same in the proper office in the Supreme Court, at Sydney, in the said Colony of New South Wales, then these Letters of Registration, and all advantages whatsoever hereby granted, shall cease and become void.

In witness whereof, I have hereunto set my sign manual, and have caused the present Letters of Registration to be sealed with the seal of the said Colony of New South Wales, at Government House, Sydney, in New South Wales, this sixth day of February, in the year of our Lord one thousand eight hundred and eighty-four.

[L.S.]

AUGUSTUS LOFTUS.

Improvements in Couplings for Tram and Railway Rolling Stock.

A.

SPECIFICATION of JOHN BROWN, of No. 42, Burnett-street, Redfern, near Sydney, in the Colony of New South Wales, engineer, for an invention entitled "Improvements in Couplings for Tram and Railway Rolling Stock."

My invention relates to that class of couplings (which are also used as buffers) whereby the rolling stock of tram and railways automatically couples itself when the vehicles are pushed together, and whereby such vehicles will remain so coupled until released by manual power, and it has been specially devised so that such couplings will be more simple in construction and more certain in action than those heretofore designed.

My improvements in couplings for tram and railway rolling stock consist first and essentially in a novel method of presenting the coupling link from between the jaw of the draw-head or buffer to which it is attached, so that when two draw-heads or buffers approach and meet said links will pass one another and each find its own way between and into the jaw from out of which the other projects. They consist, secondly, in novel methods of holding and releasing the coupling pin, so that when the link has entered the jaw said coupling pin will lock the link therein until said pin is lifted or released. They further consist in the novel combinations and arrangements of parts, hereinafter specifically set forth, which are used in carrying my invention into effect.

My improved coupling link projects through the slotted face of a draw-head or buffer, and is elastically supported at its inner end from the body of said draw-head or buffer. I prefer to so support it by springs from the ends of a draw-beam. Said draw-beam consists of an angle-piece top and bottom, centred upon a fixed pin or bolt through the stem of the draw-head or buffer, and around which pin it has a limited motion, the outer ends being connected by bolts, which carry the springs above and below the inner ends of said coupling links.

The coupling pin is held above the jaw or cavity in the stem of the draw-head or buffer by a sliding key or pin, which enters a slot through the body of said pin, and which is retained in place by a weight or spring. The coupling link in entering through the slotted face of said draw-head or buffer into said jaw strikes and moves a lever which slides said key or pin out of said slot and allows the coupling pin to fall through said link and lock the coupling link within said jaw. In a modification of this arrangement a bar is pushed inwardly by the approaching buffer and throws a spring from under a stop on the coupling pin, and thus allows it to fall and lock the coupling as in the first case. In another modification a push bar, struck by the approaching buffer, lifts the coupling pin and allows it to fall when the link is in position, so as to lock it. In all these cases the pin is lifted out of place to free the coupling in any of the well-known ways.

But in order that my invention may be clearly understood, I will now describe the same with reference to my drawings hereto attached, which show the best methods I know of carrying the same into practical operation,

Figure 1 is a plan of a combined coupling and buffer constructed according to my invention, figure 2 a side elevation, and figure 3 an end view of the same respectively, while figures 4 and 5 show two of the same coupled together, figure 4 being a sectional elevation on the line *a a* in figure 1, and figure 5 a section on the line *b b* in the same figure. A is the coupling link, B the buffer, C the draw-beam, and D the coupling pin; A¹ A¹ are bolts or pins, A² A² flat springs, B¹ the face of buffer, and B² slot therein, B³ jaw or slot in buffer stem, C¹ is bolt or centre pin, D¹ is guide bracket, D² eye bolt and guide pin, D³ long lever, and D⁴ its spindle, D⁵ short end of lever, D⁶ link or connecting rod, D⁷ key or pin, D⁸ slot.

In this case the pins D are lifted by hand before the vehicles are brought together, and the keys or pins D¹ allowed to enter slots D², where they are retained by weighted levers D³. Now, when the vehicles approach one another, coupling links A being sharp-pointed, as shown, and having the allowance of springs A², will ride one over the other, as the case may be, and enter into slot B² and jaw B³, and coming into contact with lever D³ will move said lever inwards, and the pin D⁷ out of slot D⁵, causing pin D to fall into the position shown in figures 4 and 5, and lock the coupling. The draught when the vehicles are in motion is now from bolt C¹ in draw-head or buffer B through beam C to coupling pin D in either case. Said beam C having a limited motion around bolt C¹ allows the play required when long vehicles are travelling around curves, and when the vehicles are being coupled up on curves.

Figures 6 is a side elevation, figure 7 an end view, and figure 8 a plan respectively of a modification of the coupling just described. In this case the main principle is the same, but it is carried into operation without the intervention of a draw-beam; but referring particularly to said figures, A is the coupling link, B the buffer, and D the coupling pin; A² A² are flat springs top and bottom, reaching from side to side, the centres being fixed to buffer or draw-head, while either end is fixed to and carries the inner ends of link A; B¹ is the face of buffer, B² slot therein, and B³ jaw or slot in buffer stem; D¹ is guide bracket, E is a push bar attached to weighted lever E¹, E² is a pawl, and E³ a trigger. In action, as the buffers approach and meet, push bar E will force back the top end of lever E¹, and with it pawl E², which pawl will carry back trigger E³ and lift the coupling pin D, allowing a free entrance to the link A of the other buffer, which link forces its way, being allowed to move up and down by springs A², under or over, as the case may be, the link of the buffer under review, and when pawl E² passes a certain point in its revolution, as is well understood, it releases the trigger E³ and allows the pin D to drop into place and lock the coupling, lever E² being returned to its normal position by its weighted end.

Figure 9 is a side view of an alternative means of holding the coupling pin above the jaw of the draw-head or buffer and of releasing it by the approaching together of the vehicles; F is a push bar, F¹ a spring, and F² a stop. When the pin D is raised spring F¹ catches under stop F² and supports said pin. Now, to release it the buffer-head strikes push bar F, which throws spring F¹ back from under stop F² and allows pin D to fall and lock the coupling.

To free either of these couplings it is necessary to lift coupling pins D by manual power; and to provide against the necessity of anyone getting between the vehicles to do this I fix a cord and lever or a lever on the head-stock of the vehicle so that the pin may be lifted from the side of said vehicle by a partial revolution of the spindel of said lever, as is well understood.

Having

Improvements in Couplings for Tram and Railway Rolling Stock.

Having thus particularly described and ascertained my said invention, I would have it understood that I do not confine myself to any particular materials of which my couplings may be constructed, preferring those commonly used for this class of work, nor do I confine myself to any particular kind of spring or means of obtaining elasticity, nor to the precise manner in which my said invention may be carried into effect, but what I believe to be new, and therefore claim as my improvements in couplings for tram and railway rolling stock, is—

- First—Presenting the coupling link from between the jaw of the draw-head or buffer to which it is attached so that when two draw-heads or buffers approach and meet said links will pass one over the other and each find its own way between and into the jaw from out of which the other projects, substantially as herein described and explained.
- Second—Releasing a stop or key from the coupling pin by means of the approaching together of the buffers of two vehicles so as to allow said pin to fall and lock the coupling, substantially as herein described and explained.
- Third—Lifting the coupling pin by the approaching together of the buffers or draw-heads of two vehicles and allowing it to fall so that said link has a fair entry and is locked within said jaw, substantially as herein described and explained.
- Fourth—The combination and arrangement of link A, bolts A¹, springs A², beam C, on pin C¹, and coupling pin D, with the other parts of a slotted buffer B, substantially as herein described and explained, and as illustrated in figures 1 to 5 of my drawings.
- Fifth—The combination and arrangement of the parts marked D³, D⁴, D⁵, D⁶, D⁷, and D⁸, and the link A with the coupling pin D, substantially as herein described and explained, and as illustrated in figures 1 to 5 of my drawings.
- Sixth—The combination and arrangement of link A, springs A², and pin D, with the other parts of a slotted buffer B, substantially as herein described and explained, and as illustrated in figures 6, 7, and 8 of my drawings.
- Seventh—The combination and arrangement of the parts marked E, E¹, E², and E³, and the link A with the coupling pin D, substantially as herein described and explained, and as illustrated in figures 6, 7, and 8 of my drawings.
- Eighth—The combination and arrangement of the parts marked F, F¹, and F², and the link A with coupling pin D, substantially as herein described and explained, and as illustrated in figure 9 of my drawings.

In witness whereof, I, the said John Brown, have hereto set my hand and seal, this fourteenth day of November, one thousand eight hundred and eighty-three.

Witness—

FRED WALSH,

Manager Edwd. Waters' Patent Office, Sydney.

JOHN BROWN.

This is the specification marked A referred to in the annexed Letters of Registration granted to John Brown, the sixth day of February, A.D. 1884.

AUGUSTUS LOFTUS.

REPORT.

Sir,

Referring to your B.C. instructions of the 14th ultimo, forwarding a Petition for Letters of Registration for an invention entitled "Improvements in Couplings for Tram and Railway Rolling Stock," from Mr. John Brown, of Redfern, we have the honor to state that, having examined the plan and specification accompanying the Petition, we are of opinion that Letters of Registration should be granted to the Petitioner for this invention.

We have, &c.,

JOHN WHITTON.

E. O. MORIARTY.

The Under Secretary of Justice.

[Drawings—two sheets.]

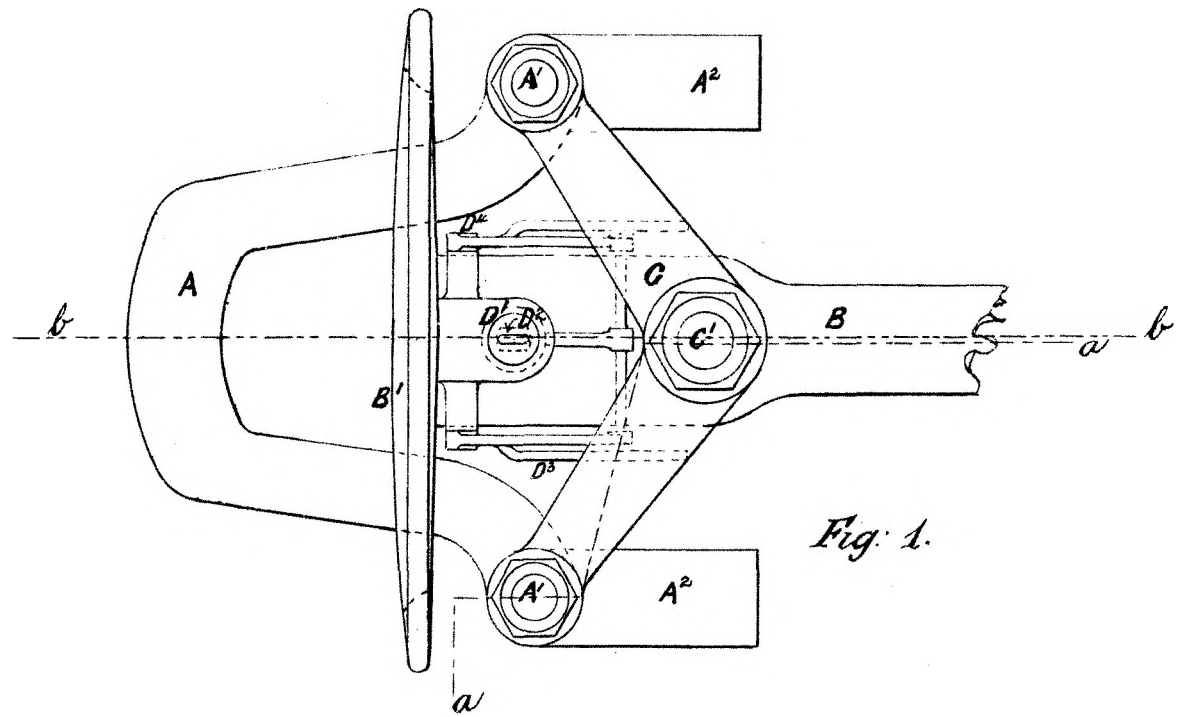


Fig. 1.

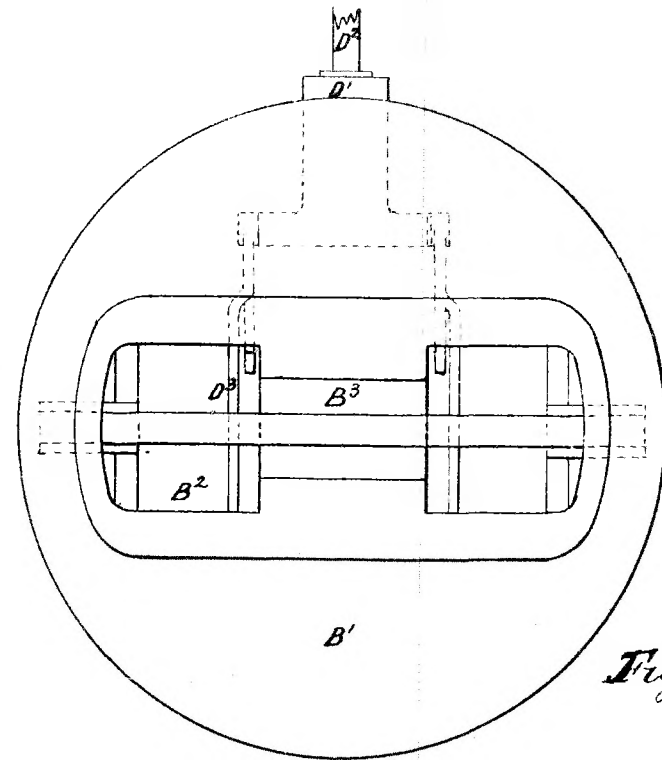


Fig. 3.

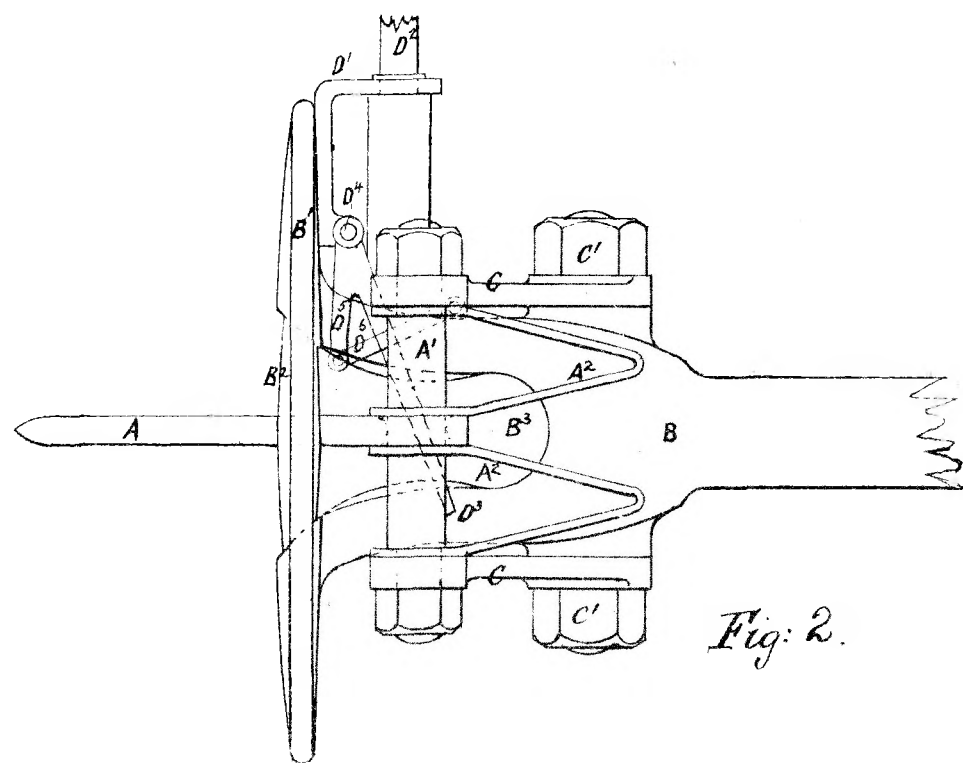


Fig. 2.

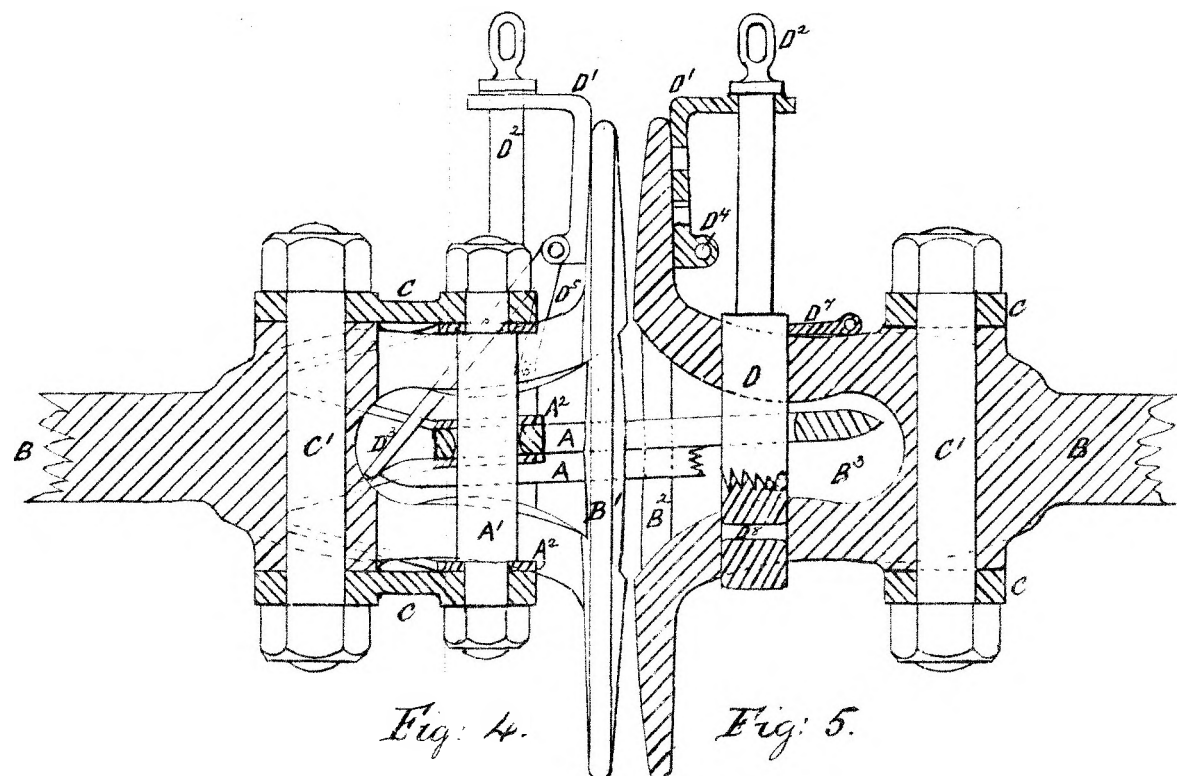


Fig. 4.

Fig. 5.

This is the Sheet of Drawings marked B, referred to in the annexed
 Letters of Registration, granted to John Brown, the sixth day of
 February, A. D., 1884. *Augustus Loftus.*

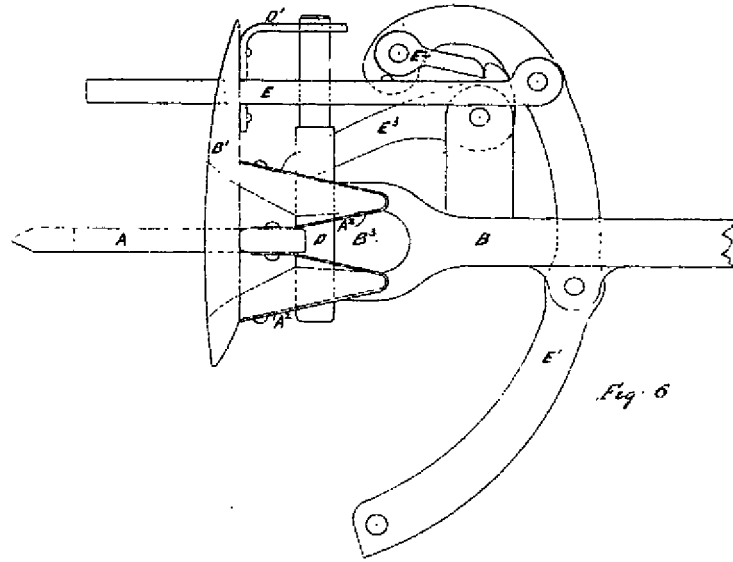


Fig. 6

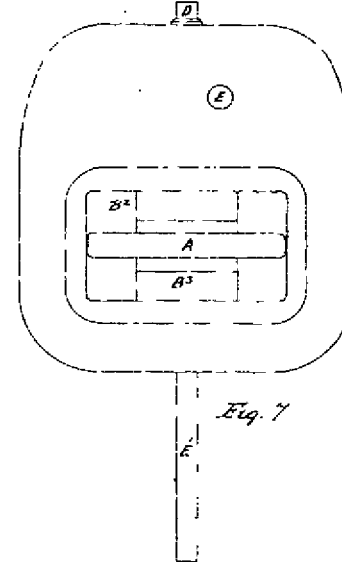


Fig. 7

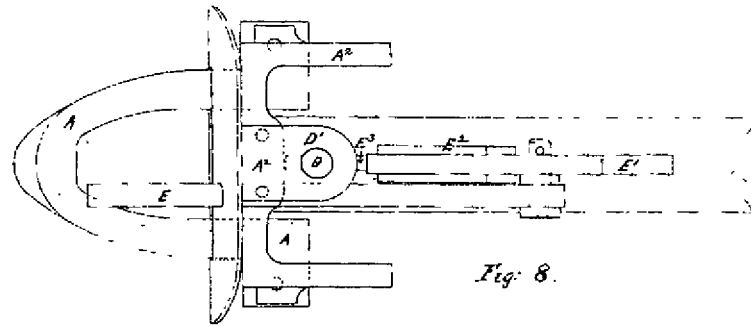


Fig. 8.

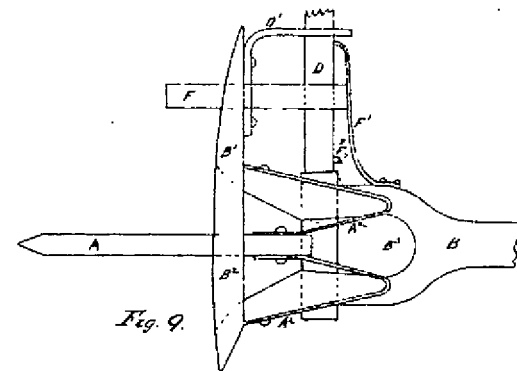


Fig. 9.

(Sig. 245~)

This is the Sheet of Drawings marked C, referred to in the several Letters of Registration granted to
 John Brown, the sixth day of February, A. D. 1884. Augustus Loftus.



A.D. 1884, 6th February. No. 1380.

IMPROVEMENTS IN SHEET LEAD ELECTRODES OF SECONDARY BATTERIES.

LETTERS OF REGISTRATION to Gaston Planté, Thomas Parker, and Paul Bedford Elwell, for Improvements in preparing the Sheet Lead Electrodes of Secondary Batteries, with a view to their rapid formation.

[Registered on the 7th day of February, 1884, in pursuance of the Act 16 Vic. No. 24.]

BY HIS EXCELLENCY THE RIGHT HONORABLE SIR AUGUSTUS WILLIAM FREDERICK SPENCER LOFTUS (commonly called LORD AUGUSTUS LOFTUS), Knight Grand Cross of the Most Honorable Order of the Bath, a Member of Her Majesty's Most Honorable Privy Council, Governor and Commander-in-Chief of the Colony of New South Wales and its Dependencies.

TO ALL TO WHOM THESE PRESENTS SHALL COME, greeting:

WHEREAS GASTON PLANTE, of Paris, France, electrician, and THOMAS PARKER and PAUL BEDFORD ELWELL, both of Wolverhampton, England, electrical engineers, have by their Petition humbly represented to me that they are the authors or designers of a certain invention or improvement in manufactures, that is to say, of an invention entitled "Improvements in preparing the sheet lead electrodes of secondary batteries, with a view to their rapid formation," which is more particularly described in the specification which is hereunto annexed; and that they, the said Petitioners, have deposited with the Honorable the Treasurer of the said Colony of New South Wales the sum of Twenty Pounds sterling, for defraying the expense of granting these Letters of Registration, as required by the Act of Council, sixteenth Victoria, number twenty-four; and have humbly prayed that I would be pleased to grant Letters of Registration, whereby the exclusive enjoyment and advantage of the said invention or improvement might be secured to them for a period of fourteen years: And I, being willing to give encouragement to all inventions and improvements in the arts or manufactures which may be for the public good, and having received a report favourable to the prayer of the said Petition, from competent persons appointed by me to examine and consider the matters stated therein and to report thereon for my information, am pleased, with the advice of the Executive Council, and in exercise of the power and authority given to me by the said Act of Council, to grant, and do by these Letters of Registration grant unto the said Gaston Planté, Thomas Parker, and Paul Bedford Elwell, their executors, administrators, and assigns, the exclusive enjoyment and advantage of the said invention or improvement, for and during the term of fourteen years from the date hereof; to have, hold, and exercise unto the said Gaston Planté, Thomas Parker, and Paul Bedford Elwell, their executors, administrators, and assigns, the exclusive enjoyment and advantage thereof, for and during and unto the full end and term of fourteen years from the date of these presents next and immediately ensuing, and fully to be complete and ended: Provided always, that if the said Gaston Planté, Thomas Parker, and Paul Bedford Elwell shall not, within three days after the granting of these Letters of Registration, register the same in the proper office in the Supreme Court, at Sydney, in the said Colony of New South Wales, then these Letters of Registration, and all advantages whatsoever hereby granted, shall cease and become void.

In witness whereof, I have hereunto set my sign manual, and have caused the present Letters of Registration to be sealed with the seal of the said Colony of New South Wales, at Government House, Sydney, in New South Wales, this sixth day of February, in the year of our Lord one thousand eight hundred and eighty-four.

[L.S.]

AUGUSTUS LOFTUS.

Improvements in Sheet Lead Electrodes of Secondary Batteries.

SPECIFICATION of GASTON PLANTÉ, of Paris, France, electrician, and THOMAS PARKER and PAUL BEDFORD ELWELL, both of Wolverhampton, in the County of Stafford, England, electrical engineers, for an invention entitled "Improvements in preparing the Sheet Lead Electrodes of Secondary Batteries, with a view to their rapid formation."

ACCORDING to this invention the lead electrodes for employment in secondary or storage batteries (known as Planté batteries) are prepared, in order to facilitate their development under the action of the electric current, by immersing them in a dilute solution of nitric acid or of nitric and sulphuric acids mixed.

When dilute nitric acid only is employed such acid is diluted with from once to twice its volume of water, and the electrodes are immersed therein for a space of about twenty-four hours or more before submitting them to the action of the primary current.

The acid solution may be weaker than is expressed above, but of course in such case the immersion must be for a longer period. The electrodes are then washed (preferably) and transferred to an ordinary Planté battery solution (consisting of dilute sulphuric acid in the proportion of say one part of acid to nine parts of water) for their development by the electric current.

When the mixed acid solution referred to above is employed for the preparation of the electrodes the solution consists preferably of about $\frac{2}{3}$ nitric acid, $\frac{1}{3}$ sulphuric acid, and $\frac{1}{2}$ water, but the proportions may be varied to almost any desired extent. It is preferred also to maintain the temperature at about 90° Fahrenheit. The electrodes are immersed in the mixed solution for about forty-eight hours, more or less, when they are ready for immersion in the ordinary Planté battery solution for their development by the electric current. The electrodes are preferably washed after immersion in the mixed acid solution, and before being made up into cells.

The nitric acid (whether used alone or mixed with sulphuric acid) oxidises and dissolves some of the lead sheet forming an electrode, and thus causes a roughening, corroding, or minute honey-combing of the sheet, whereby it is made capable of having formed upon it, and of retaining thereupon when so formed, a larger proportion of peroxide of lead during the action of the battery, than if such sheet were employed with its surface in its originally smooth condition. When the mixed acid solution aforesaid is employed there is also formed upon the electrodes, during their preparation, sulphate of lead to any desired extent, and this salt deposited upon the roughened surface (produced by the action of the nitric acid in the solution) subsequently becomes converted during the action of the battery into peroxide of lead, or spongy lead, according to the direction of the current.

The nitric acid of the mixed acid solution acting upon the lead in the presence of dilute sulphuric acid is partially regenerated for further action, the lead being precipitated in the form of a sulphate, as before stated. When the mixed acid solution is employed it will be found of advantage to form each electrode of several layers of sheet, as between such layers the action of the acids will form, and leave retained, the insoluble sulphate of lead.

Instead of commencing the preparation of the electrodes in the mixed acid solution as described, such preparation may be commenced in a solution of nitric acid to which the sulphuric acid is afterwards added, with the same effect as is produced by the employment of the mixed acid solution throughout the preparation. When the mixed acid solution is employed, the electrodes may, if desired, be developed in the solution in which they are prepared, in which case the electrolytic hydrogen discharges the nitric acid from the solution, thus leaving a solution consisting essentially of dilute sulphuric acid suitable for the continuous working of the battery. By this latter method of developing the electrodes, however, the nitric acid is lost and energy is expended in discharging it.

The electrodes may be prepared with similar effect to that already described by placing them in the vapour of the acid or mixed acid solution described.

The electrodes (forming secondary cells) prepared in either manner before described, will, after having been submitted for a few hours to the action of the primary current, give off a discharge current lasting for a long period, whereas, when they have not been previously prepared, several weeks of electric action are required before they will give the same results. Reversing the direction of the primary current, which is so useful for the operation which the said Gaston Planté described in 1872 under the name of "formation" of secondary cells, is equally efficacious in the present case without it being necessary to so frequently effect this change.

Acid must, of course, be supplied from time to time to strengthen the solutions aforesaid.

The sheets of lead intended to be employed in the construction of the electrodes may be prepared as above described, if preferred, before being formed into electrodes.

Having thus described the nature of our said invention, and the manner of performing the same, we declare that what we claim as our invention is—

The use of dilute nitric acid either alone or mixed with sulphuric acid for the rapid "formation" of lead plates of secondary batteries, substantially as above described and for the purpose set forth.

In witness whereof, we, the said Gaston Planté, Thomas Parker, and Paul Bedford Elwell have, hereto set our hands and seals, this sixteenth day of October, 1883.

GASTON PLANTE,
THOMAS PARKER,
P. BEDFORD ELWELL.

This is the specification referred to in the annexed Letters of Registration granted to Gaston Planté, Thomas Parker, and Paul Bedford Elwell, the sixth day of February, A.D. 1884.

AUGUSTUS LOFTUS.

REPORT.

Sir,

We do ourselves the honor to report that we are of opinion Letters of Registration may issue in accordance with the petition of Gaston Planté and others, for an invention entitled, "Improvements in preparing the Sheet Lead Electrodes of Secondary Batteries with a view to their rapid formation" as detailed in their specification and claim, transmitted under your blank cover 30th ultimo, No. 14,145.

We have, &c.,

E. C. CRACKNELL,
GOTHER K. MANN.

The Under Secretary of Justice.

Sydney, 6 December, 1883.



A.D. 1884, 6th February. No. 1381.

AN IMPROVED METHOD OF AUTOMATICALLY OPENING OR CLOSING VALVES
OR COCKS AT ANY GIVEN PERIOD OF TIME.

LETTERS OF REGISTRATION to Horace Stevens, for an Improved Method
of Automatically Opening or Closing Valves or Cocks at any given period
of time.

[Registered on the 7th day of February, 1884, in pursuance of the Act 16 Vic. No. 24.]

BY HIS EXCELLENCY THE RIGHT HONORABLE SIR AUGUSTUS WILLIAM FREDERICK SPENCER LOFTUS
(commonly called LORD AUGUSTUS LOFTUS), Knight Grand Cross of the Most Honorable Order of
the Bath, a Member of Her Majesty's Most Honorable Privy Council, Governor and Commander-in-
Chief of the Colony of New South Wales and its Dependencies.

TO ALL TO WHOM THESE PRESENTS SHALL COME, greeting:

WHEREAS Horace Stevens, of No. 94, Collins-street East, in the city of Melbourne and Colony
of Victoria, dental practitioner, hath by his petition humbly represented to me that he is the author or
designer of a certain invention or improvement in manufactures, that is to say, of an invention entitled
"An Improved Method of Automatically Opening or Closing Valves or Cocks at any given period of time,"
which is more particularly described in the specification and the sheet of drawings which are here-
unto annexed; and that he, the said Petitioner, hath deposited with the Honorable the Treasurer of
the said Colony of New South Wales the sum of Twenty Pounds sterling, for defraying the expense of
granting these Letters of Registration, as required by the Act of Council, sixteenth Victoria, number
twenty-four; and hath humbly prayed that I would be pleased to grant Letters of Registration, whereby
the exclusive enjoyment and advantage of the said invention or improvement might be secured to him for
a period of fourteen years: And I, being willing to give encouragement to all inventions and improve-
ments in the arts and manufactures which may be for the public good, and having received a report favour-
able to the prayer of the said Petition, from competent persons appointed by me to examine and consider
the matters stated therein and to report thereon for my information, am pleased, with the advice of the
Executive Council, and in exercise of the power and authority given to me by the said Act of Council, to
grant, and do by these letters of Registration grant unto the said Horace Stevens, his executors,
administrators, and assigns, the exclusive enjoyment and advantage of the said invention or improvement,
for and during the term of fourteen years from the date hereof; to have, hold, and exercise unto the
said Horace Stevens, his executors, administrators, and assigns, the exclusive enjoyment and advantage
thereof, for and during and unto the full end and term of fourteen years from the date of these presents
next and immediately ensuing, and fully to be complete and ended: Provided always, that if the said
Horace Stevens shall not, within three days after the granting of these Letters of Registration, register
the same in the proper office in the Supreme Court, at Sydney, in the said Colony of New South Wales,
then these Letters of Registration, and all advantages whatsoever hereby granted, shall cease and become
void.

In witness whereof, I have hereunto set my sign manual, and have caused the present Letters of
Registration to be sealed with the seal of the said Colony of New South Wales, at Govern-
ment House, Sydney, in New South Wales, this sixth day of February, in the year of our
Lord one thousand eight hundred and eighty-four.

[L.S.]

AUGUSTUS LOFTUS.

An Improved Method of Automatically Opening or Closing Valves, &c.

SPECIFICATION of HORACE STEVENS, of No. 94, Collins-street East, in the city of Melbourne and Colony of Victoria, dental practitioner, for an invention entitled "An Improved Method of Automatically Opening or Closing Valves or Cocks at any given period of time."

My invention consists of an improved method of automatically opening or closing valves or cocks at any given period of time, and has been designed for such purposes as turning off or turning on a supply of gas or water at any special time. My method is to connect the valve or cock with the alarum spindle of an alarum clock, and to set such clock so that the alarum will be set in motion at the time when the valve or cock is required to be opened or closed. The motion of the alarum moves the connection between it and the valve or cock, turning it on or off, as the case may be, at that precise period of time.

In order, however, that my invention may be more clearly understood, I will now refer to the drawings hereto attached, in which two kinds of alarum clocks are shown as being used for the purposes herein described. In figure 1, an ordinary circular nickel alarum clock is used, A being the spindle of the alarum, and B the arm or rod which springs from it and reaches sufficiently far to strike an attachment C to the handle C' of the cock C². When the point of time has been reached at which the cock is to be opened or closed the alarum spindle A will commence to revolve, carrying with it the arm B, which, by pressing against the attachment C, closes the cock C². Of course the alarum and the pipe to which the cock is attached must each be fixtures, so that neither will move when the alarum commences to work. Figure 2 is a plan of this arrangement.

In figure 3 a wooden alarum clock is shown, in which the position of the alarum spindle is somewhat different, and in which the end of the arm or rod B is somewhat curved at the end so as to prevent its escape. In all substantial particulars, however, the arrangement is identical with that shown in figure 1.

The motion of the alarum spindle might be used in other ways for the purposes of this invention; for instance, it might be used either through the medium of mechanical devices and forces such as are herein described, or it might be used as a means of making or breaking an electrical connection.

What I believe to be new, and therefore claim as my improved method of automatically opening or closing valves or cocks at any given period of time, is the combination of an alarum clock with such valves or cocks in the manner substantially as herein described and explained.

In witness whereof, I, the said Horace Stevens, have hereto set my hand and seal, this fifteenth day of November, one thousand eight hundred and eighty-three.

Witness—

EDWARD WATERS,
Melbourne, Patent Agent.

HORACE STEVENS.

This is the specification referred to in the annexed Letters of Registration granted to Horace Stevens, the sixth day of February, A.D. 1884.

AUGUSTUS LOFTUS.

REPORT.

Sir,

We do ourselves the honor to state, in reply to your blank cover, 8 December, No. 14,380, transmitting the petition of Horace Stevens for the registration of "An improved method of automatically opening or closing valves or cocks, at any given period of time," that we are of opinion the prayer of the Petitioner may be granted, in accordance with his specification, drawings, and claim.

We have, &c.,

E. C. CRACKNELL,
GOTHEK K. MANN.

The Under Secretary of Justice.

H. STEVENS' PATENT.

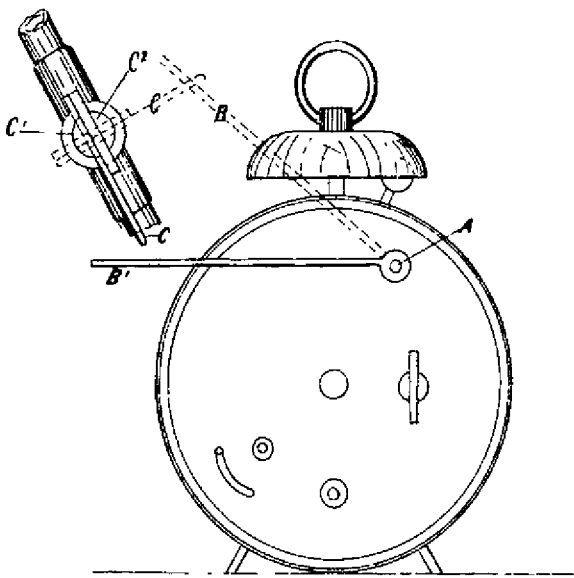


Fig: 1.

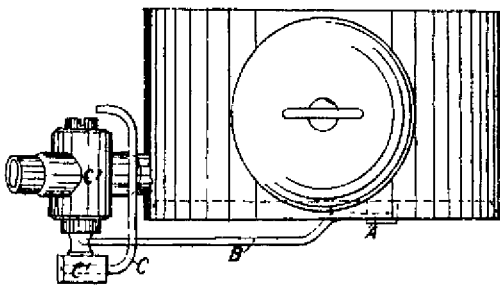


Fig: 2.

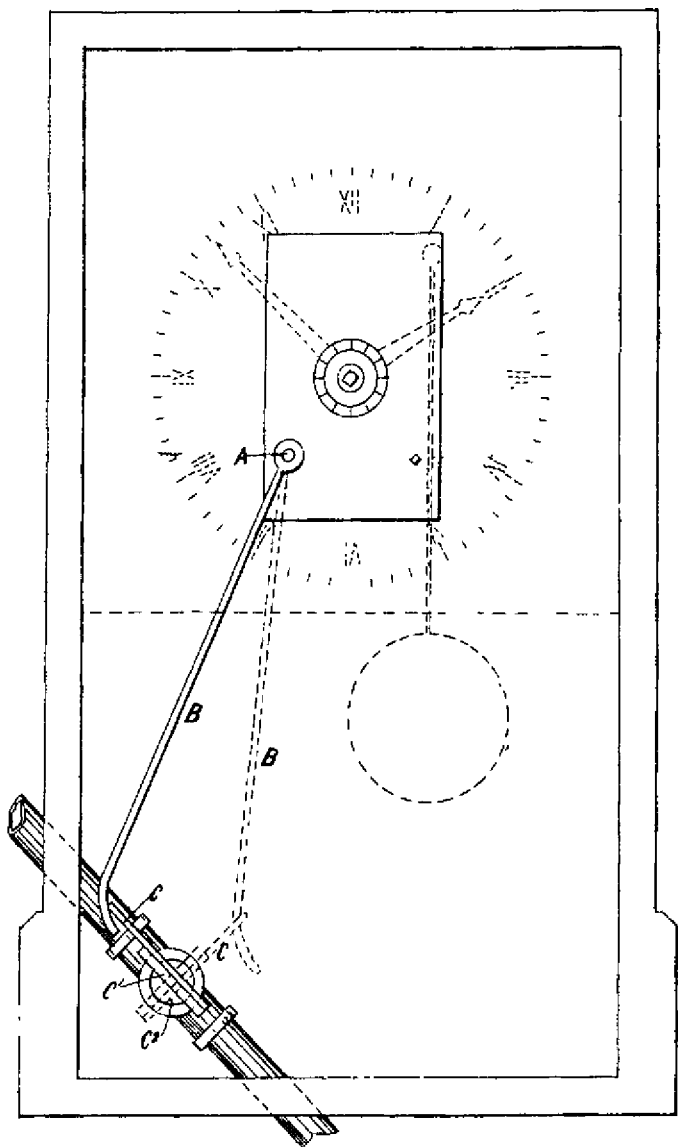


Fig: 3.

This is the Sheet of Drawings referred to in the annexed Letters of Registration, granted to Horace Stevens, the sixth day of February, A.D., 1884.

Augustus Loftus.

(Sig: 245-)



A.D. 1884, 6th February. No. 1382.

AN IMPROVED SHEEP AND CATTLE LABEL, AND IMPROVED PLIERS FOR FASTENING THEM IN POSITION.

LETTERS OF REGISTRATION to Edwin John Dark and Frank Thomas Bury for an Improved Sheep and Cattle Label, and improved Pliers for fastening them in position.

[Registered on the 7th day of February, 1884, in pursuance of the Act 16 Vic. No. 24.]

BY HIS EXCELLENCY THE RIGHT HONORABLE SIR AUGUSTUS WILLIAM FREDERICK SPENCER LOFTUS (commonly called LORD AUGUSTUS LOFTUS), Knight Grand Cross of the Most Honorable Order of the Bath, a Member of Her Majesty's Most Honorable Privy Council, Governor and Commander-in-Chief of the Colony of New South Wales and its Dependencies.

TO ALL TO WHOM THESE PRESENTS SHALL COME, greeting :

WHEREAS EDWIN JOHN DARK, of No. 19, Little Bourke-street West, in the City of Melbourne and Colony of Victoria, general smith, and FRANK THOMAS BURY, of Claremont-street, South Yarra, in the said Colony of Victoria, clerk, hath by their Petition humbly represented to me that they are the authors or designers of a certain invention or improvement in manufactures, that is to say, of an invention entitled, "An Improved Sheep and Cattle Label, and improved Pliers for fastening them in position," which is more particularly described in the specification and the sheet of drawings which are hereunto annexed; and that they, the said Petitioners, have deposited with the Honorable the Treasurer of the said Colony of New South Wales the sum of Twenty Pounds sterling, for defraying the expense of granting these Letters of Registration, as required by the Act of Council, sixteenth Victoria, number twenty-four; and have humbly prayed that I would be pleased to grant Letters of Registration, whereby the exclusive enjoyment and advantage of the said invention or improvement might be secured to them for a period of fourteen years: And I, being willing to give encouragement to all inventions and improvements in the arts or manufactures which may be for the public good, and having received a report favourable to the prayer of the said Petition, from competent persons appointed by me to examine and consider the matters stated therein and to report thereon for my information, am pleased, with the advice of the Executive Council, and in exercise of the power and authority given to me by the said Act of Council, to grant, and do by these Letters of Registration grant unto the said Edwin John Dark and Frank Thomas Bury, their executors, administrators, and assigns, the exclusive enjoyment and advantage of the said invention or improvement, for and during the term of fourteen years from the date hereof; to have, hold, and exercise unto the said Edwin John Dark and Frank Thomas Bury, their executors, administrators, and assigns, the exclusive enjoyment and advantage thereof, for and during and unto the full end and term of fourteen years from the date of these presents next and immediately ensuing, and fully to be complete and ended: Provided always, that if the said Edwin John Dark and Frank Thomas Bury shall not, within three days after the granting of these Letters of Registration, register the same in the proper office in the Supreme Court, at Sydney, in the said Colony of New South Wales, then these Letters of Registration, and all advantages whatsoever hereby granted, shall cease and become void.

In witness whereof, I have hereunto set my sign manual, and have caused the present Letters of Registration to be sealed with the seal of the said Colony of New South Wales, at Government House, Sydney, in New South Wales, this sixth day of February, in the year of our Lord one thousand eight hundred and eighty-four.

[L.S.]

AUGUSTUS LOFTUS.

An Improved Sheep and Cattle Label, &c.

SPECIFICATION of EDWIN JOHN DARK, of No. 19, Little Bourke-street West, in the City of Melbourne, and Colony of Victoria, general smith, and FRANK THOMAS BURY, of Claremont-street, South Yarra, in the said Colony, clerk, for an invention entitled "An improved Sheep and Cattle Label, and improved Pliers for fastening them in position."

Our improved sheep and cattle label consists of two metallic plates or discs, one having holes in it, and the other having legs or points to it. The latter is placed on one side of the ear and its points pressed through to the other side and then through the holes in the second plate. Their ends are then bent over said second plate, so as to hold the two together with the animal's ear in between.

Our improved pliers for fastening our labels in position are ordinary spring pliers with a recess on each face, the one being shaped so as to receive the one plate, and the other so as to receive the other plate, and each having a spring point to fit into a little recess in the side of the plate, so as to ensure its being in such a position as that the legs or points in one plate will, when the two faces are pressed together, pass through the holes in the other, and with a bevelled recess behind the holes in the oblong plate to receive and turn down the ends of such points or legs.

These discs or plates may be of any size or shape, but we prefer to have the front one circular and with legs or points, and the back one oblong and with holes. In our drawings they are shown full size. Figures 1, 2, and 3 represent different views of the circular disc; figure 1, as originally stamped; figure 2, with its legs turned down; and figure 3, an edge view. Figures 4 and 5 show respectively section and plan of the oblong disc or plate; figures 6, 7, and 8 show respectively front, back, and sectional views of our label attached to an animal's ear; figure 9 shows the pliers; figure 10 their lower face; and figure 11 their upper face. It will be noticed that in the upper face there are bevelled recesses indicated by dotted lines to show how the points of the front disc are turned down. A is the circular disc having legs or points A¹ and a recess A²; B is the back disc or plate, B¹ the holes therein, and B² a recess in its side. In figures 6, 7, and 8 C is the animal's ear. In figure 9 A³ is the recess for disc A, and B³ the recess for disc B; A⁴ and B⁴ are springs.

The disc A is first stamped out as at figure 1, then its legs are turned down as at figure 2; then it is put into the recessed face A³ of the pliers. The disc B, stamped as in figure 5, is placed in the recessed face B³ of the pliers, the springs A⁴ and B⁴ and recesses A² and B² ensuing both discs being in proper position; the animal's ear is then placed between, and by one squeeze the points or legs A¹ pass through the ear, then through the holes B¹, and then the projecting ends are turned down so that the attachment of the label is quite completed at one operation. We take care to make the holes in disc B of such a size as not to allow the legs or points A¹ to pass through too far, but always so as to leave sufficient room for the animal's ear without squeezing it.

Our labels may be made of any suitable metal, but we prefer tin.

What we claim as our invention is—

First—Our improved sheep and cattle label, consisting of two metallic discs, one having points or legs, and the other having holes to receive them, to be used in the manner substantially as herein described and explained.

Second—Our improved pliers for holding such labels and fastening them on to the animal's ear substantially as herein described and explained, the novelty in this case lying only in the construction of the faces.

In witness whereof, we, the said Edwin John Dark and Frank Thomas Bury, have hereto set our hands and seals, this twenty-ninth day of November, one thousand eight hundred and eighty-three.

E. J. DARK,
For self and F. T. BURY.

Witness—
W. S. BAYSTON,
Patent Law Clerk, Melbourne.

This is the specification referred to in the annexed Letters of Registration granted to Edwin John Dark and Frank Thomas Bury, the sixth day of February, A.D. 1884.

AUGUSTUS LOFTUS.

REPORT.

Sir,

Sydney, 10 December, 1883.

We do ourselves the honor to return to you herewith the application on behalf of Messrs. Dark and Bury for Letters of Registration for an invention entitled "An improved Sheep and Cattle Label, and improved Pliers for fastening them in position"; and we have to report that we see no objection to the issue of letters asked for, in terms of the specification, drawing, and claim.

We have, &c.,
EDMUND FOSBERY.
JAMES BARNET.

The Under Secretary of Justice.

Dark & Bury's Patent

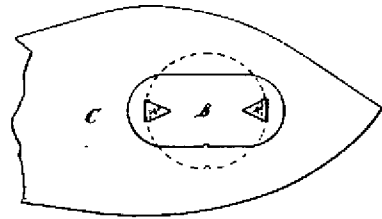


Fig. 7.

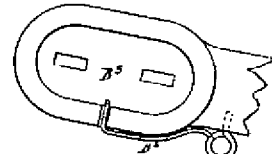


Fig. 11.



Fig. 8.

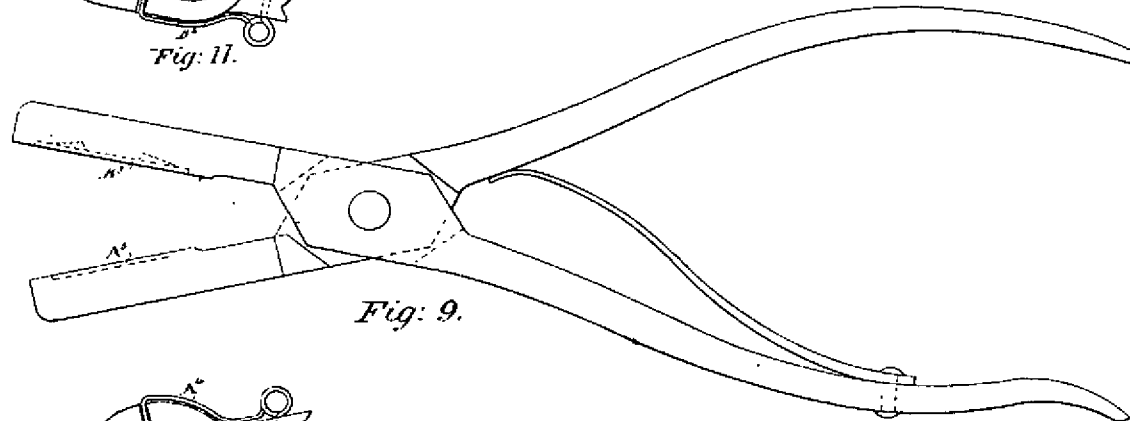


Fig. 9.

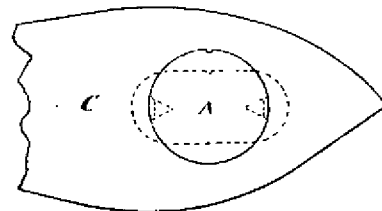


Fig. 6.

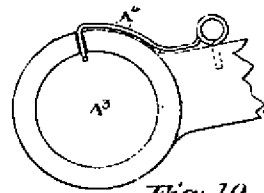


Fig. 10.



Fig. 5.

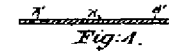


Fig. 4.

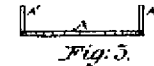


Fig. 3.



Fig. 2.

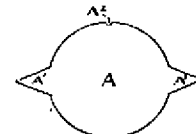


Fig. 1.

This is the Sheet of Drawings referred to in the annexed Letters of Registration, granted to Edwin John Dark and Frank Thomas Bury, the sixth day of February, A. D., 1884.

Augustus Loftus.



A.D. 1884, 6th February. No. 1383.

THE GIBBS-BARRETT AUTOMATIC MULTICOLOUR PRINTING APPARATUS.

LETTERS OF REGISTRATION to Joseph Thomas Burton Gibbs, for an invention entitled "The Gibbs-Barrett Automatic Multicolour Printing Apparatus."

[Registered on the 7th day of February, 1884, in pursuance of the Act 16 Vic. No. 24.]

BY HIS EXCELLENCY THE RIGHT HONORABLE SIR AUGUSTUS WILLIAM FREDERICK SPENCER LOFTUS (commonly called LORD AUGUSTUS LOFTUS), Knight Grand Cross of the Most Honorable Order of the Bath, a Member of Her Majesty's Most Honorable Privy Council, Governor and Commander-in-Chief of the Colony of New South Wales and its Dependencies.

TO ALL TO WHOM THESE PRESENTS SHALL COME, greeting :

WHEREAS JOSEPH THOMAS BURTON GIBBS, of No. 70, Pitt-street, Sydney, in the Colony of New South Wales, artist engraver, hath by his Petition humbly represented to me that he is the assignee (so far as the Colony of New South Wales is concerned) of John Fitzallen Barrett, of Sydney aforesaid, who is the author or designer of a certain invention or improvement in manufactures, that is to say, of an invention entitled "The Gibbs-Barrett Automatic Multicolour Printing Apparatus," which is more particularly described in the specification and the sheet of drawings which are hereunto annexed; and that he, the said Petitioner, hath deposited with the Honorable the Treasurer of the said Colony of New South Wales the sum of Twenty Pounds sterling, for defraying the expense of granting these Letters of Registration, as required by the Act of Council, sixteenth Victoria, number twenty-four; and hath humbly prayed that I would be pleased to grant Letters of Registration, whereby the exclusive enjoyment and advantage of the said invention or improvement might be secured to him for a period of fourteen years: And I, being willing to give encouragement to all inventions and improvements in the arts or manufactures which may be for the public good, and having received a report favourable to the prayer of the said Petition, from competent persons appointed by me to examine and consider the matters stated therein and to report thereon for my information, am pleased, with the advice of the Executive Council, and in exercise of the power and authority given to me by the said Act of Council, to grant, and do by these Letters of Registration grant unto the said Joseph Thomas Burton Gibbs, his executors, administrators, and assigns, the exclusive enjoyment and advantage of the said invention or improvement, for and during the terms of fourteen years from the date hereof; to have, hold, and exercise unto the said Joseph Thomas Burton Gibbs, his executors, administrators, and assigns, the exclusive enjoyment and advantage thereof, for and during and unto the full end and term of fourteen years from the date of these presents next and immediately ensuing, and fully to be complete and ended: Provided always, that if the said Joseph Thomas Burton Gibbs shall not, within three days after the granting of these Letters of Registration, register the same in the proper office in the Supreme Court, at Sydney, in the said Colony of New South Wales, then these Letters of Registration, and all advantages whatsoever hereby granted, shall cease and become void.

In witness whereof, I have hereunto set my sign manual, and have caused the present Letters of Registration to be sealed with the seal of the said Colony of New South Wales, at Government House, Sydney, in New South Wales, this sixth day of February, in the year of our Lord one thousand eight hundred and eighty-four.

[L.S.]

AUGUSTUS LOFTUS.

The Gibbs-Barrett Automatic Multicolour Printing Apparatus.

TO ALL WHOM TO WHOM THESE PRESENTS SHALL COME: I, JOSEPH THOMAS BURTON GIBBS, of No. 70, Pitt-street, Sydney, artist engraver, send greeting:

WHEREAS I am desirous of obtaining Letters of Registration for securing unto myself Her Majesty's special license that I, my executors, administrators, and assigns, and such others as I or they shall at any time agree with, and no others, shall and lawfully may from time to time and at all times during the period of fourteen years, to be computed from the day on which this instrument shall be left at the office of the Minister for Justice, Sydney, make, use, exercise, and vend within the Colony of New South Wales, an invention of improvements in automatic multicolour printing, to be styled or entitled "The Gibbs-Barrett Automatic Multicolour Printing Apparatus," as more particularly set forth and described in the following specification and drawings forwarded herewith.

SPECIFICATION.

THE Gibbs-Barrett Multicolour Apparatus is designed to print, at one impression, two or more colours, with any number of transportations of said colours on paper, calico, or other substances. It can be applied to any typographic, lithographic, or other printing machinery.

It is perfectly automatic in its action, and can be used by any intelligent machinist without special training.

It will print in different colours at one impression, straight lines, curves, borders round pages, parts of lines, and even single words in any one line may be brought out in a special colour, as the display may require.

It will print parallel lines in different colours with only a fiftieth of an inch space between them, and angular or curved work also with only a fiftieth of an inch.

It will do the finest ground or map tint printing in various colours at one impression off a single block or stone.

There is no tendency of the various colours to mingle at edges.

The addition of this apparatus does not detract from the produce of the machine to which it is applied, the multicolour work coming through at the speed of one-colour printing.

The forme is set up precisely as if intended for one colour, and so long as the spaces between lines or words are from twenty to fifty parts of an inch wide the forme can be printed in any required number of colours at one impression.

The work being done at one impression the most perfect register is ensured.

Different patches of colour can also be simultaneously printed by cutting the rollers instead of the tent blocks or electros.

The difference between this and other multicolour printing machines is that the printing is done directly from the forme, block, or stone, &c., and that the latter receive ink from two rollers, ensuring evenness of colour. By duplicating apparatus double the rolling power would be obtained, four rollers passing over forme instead of two only.

VARIETIES OF WORK FOR WHICH IT IS PARTICULARLY WELL ADAPTED.

Circulars, Handbills, Playbills, Posters, &c., in straight lines, or where three or four or more colour patches (of any shape or form) are required to give prominence to the various items advertised.

Maps.—Where tints of various colours are required, so long as the part of an inch space can be given between each.

Show Cards.—Where on large type novelties may be introduced, such as printing longitudinally one line (curved or straight) in various colours, printing the different words in one line in various colours, or picking out in colours initial letters.

Graduated Colours.—At one impression, as ground and sky tints blended under an engraving or lithograph in black, or "rainbow" printing.

Formes or Blocks.—Where very heavy as well as very light patches occur, are easily worked by this apparatus, as by throwing off one or two of the ink sections, as may be necessary, the requisite gradation of colour may be obtained.

DESCRIPTION OF APPARATUS.

The apparatus is made in two parts, so that the ink ducts and distributors can be detached and slid along frame of machine, so as to give free access to the pattern drums F 1, F 2, F 3, and main sectional pattern drum 6. The pattern drums are turned to a size so as to allow them to be covered with a coating of composition or other material upon which the patterns are cut. A is the ink duct for section 1; B is the ink cylinder; C is the ink ducter, carrying ink on to distributor D, which in turn transmits ink on to composition rollers E and E 2; they then ink pattern roller F 1, which conveys the ink on to complete pattern drum 6, which in its turn carries the ink to forme rollers H 1 and H 2, which then ink the forme, stone, &c.; I 1, sections 2 and 3, act precisely as section 1, each section, of course, carrying a different colour.

WORKING OF APPARATUS.

When ready to lay a forme on, the first thing is to unscrew inking sections 1, 2, and 3, which are all in one, and slide them back a convenient distance on frame of machine, so as to give room to remove and replace the pattern rollers. The forme, block, or stone, is then laid on the bed of the machine in the ordinary way. The forme is then inked by hand-roller, a sheet is run through to determine the exact position of the forme or the paper (this is advisable, as if the patterns are cut, and the margins are found to be incorrect, much delay would be caused by shifting the patterns), the position being right, the forme is again inked, the machine slowly turned, and a transfer is received on type rollers H 1 and H 2, which is by the motion of the machine conveyed on to main pattern drum C; you now proceed to cut pattern on main drum 6, which is done by cutting a dividing line (see sample marked A) between each colour intended to be printed, say, yellow, blue, and red; this being done, pattern-rollers F 3, F 2, and F 1, are placed in position,
main

The Gibbs-Barrett Automatic Multicolour Printing Apparatus.

main sectional drum 6, on which the dividing lines are already cut, is then inked by hand in one colour; the machine is again turned slowly and the pattern is transferred on to the pattern rollers F 1, F 2, and F 3. For clearness, say, make F 1 the red ink section, F 2 blue ink section, F 3 yellow ink section. The three pattern rollers are then removed, and the machine is so arranged that these rollers can be removed or replaced instantly without interfering with the gear, so that in replacing the register of the patterns is not interfered with. F 1 being the red ink section, the composition or other material used for making the patterns is all cut away except the parts which are to be printed in red, and so with sections F 2 and F 3 in their respective colours. The machine should now be washed up, the ductors supplied with the desired colours, and by means of a handle attachable to section 2, sections 1 and 3 being connected by driving gear, the three colours can be worked up and distributed at one time up to pattern inking rollers E, in each section; the inking section is now pushed forward into position as to ink pattern rollers F 1, F 2, and F 3, they in turn convey to main pattern drum 6 the three colours, and give a complete transfer in the three colours; this transfer is then conveyed on to inking drums, which finally ink the stone or forme. There being two inking rollers is a guarantee that the forme will be properly inked. The machine is now fed in the usual way, and three colours printed at one impression at the usual rate of the machine to which apparatus is attached.

ADVANTAGES CLAIMED FOR APPARATUS.

The forme is laid on as if for one colour; the compositor saving the time of making up a forme for each colour. The time consumed by machinist in cutting patterns and making ready on this apparatus will just about equal the time for laying on three formes in the ordinary way, thus saving two-thirds of the runs of machine if made for three colours and their possible changes.

The forme is inked by two rollers, thus ensuring perfect inking.

The apparatus is so arranged that when the machine is at a standstill the pattern drums do not rest against each other, so avoiding the flattening of the patterns which is so apt to take place otherwise.

By the employment of carriers and disconnected gear-wheels on the pattern rollers, same can be removed for cutting patterns and replaced exactly in register (see figure 4).

As the various colours are printed direct from the one forme, register must necessarily be perfect.

As the inking apparatus is separate and can be slid along the frame of machine out of the way of machine, the pattern rollers can be removed and replaced with the greatest ease.

The ductors being all arranged at one end of the apparatus are as easily manipulated as on an ordinary machine.

The mode of getting the transfer direct from type, block, or stone, being automatic, and consequently accurate.

The drums are all run on steel-point centres and bearings, thus avoiding wear and vibration.

The addition of this apparatus to any machine does not detract from ordinary speed.

NOTE.—By decreasing the size of the pattern drums, and other modifications fully provided for in the construction of the apparatus, an increased number of impressions may be got from one forme.

J. T. B. GIBBS,
Assignee of John Fitzallen Barrett.

Per HENRY HALLORAN, Patent Agent,
2, Wentworth Court, Sydney, 8 November, 1883.

This is the specification referred to in the annexed Letters of Registration granted to Joseph Thomas Burton Gibbs, the 6th day of February, A.D. 1884.

AUGUSTUS LOFTUS.

REPORT.

Sir,

The application of Joseph Thomas Burton Gibbs for Letters of Registration for an invention entitled "The Gibbs-Barrett Automatic Multicolour Printing Apparatus," having been referred to us, we have examined the plan and specification accompanying the same, and have now the honor to report that we see no objection to the issue of Letters of Registration as applied for.

Sydney, 10 December, 1883.

We have, &c.
ARCH. FRASER,
THOS. RICHARDS.

The Under Secretary of Justice.

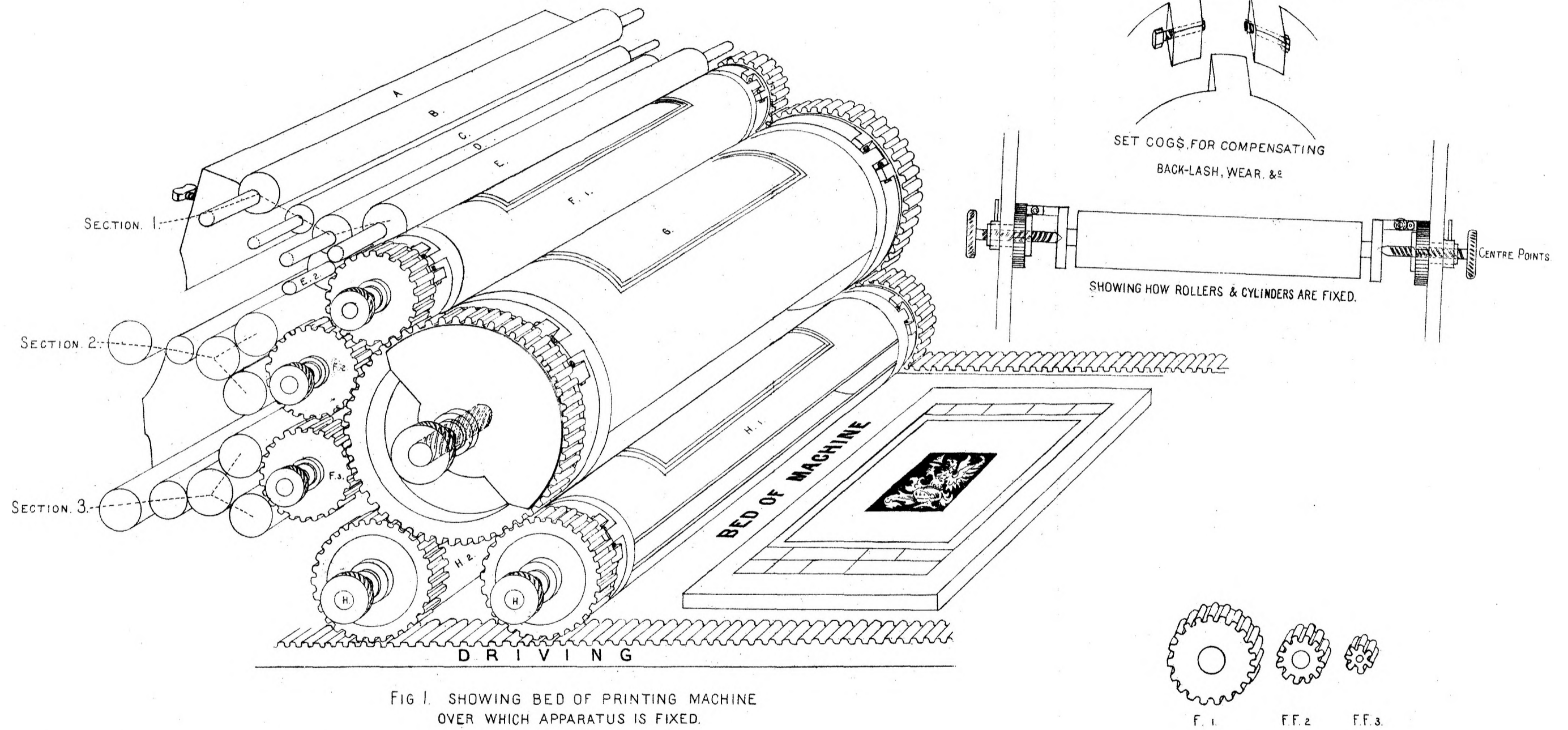


FIG 1. SHOWING BED OF PRINTING MACHINE OVER WHICH APPARATUS IS FIXED.

This is the Sheet of Drawings referred to in the annexed Letters of Registration, granted to Joseph Thomas Burton Gibbs, the sixth day of February, A. D., 1884, Augustus Loftus.

(Sig: 245-)



A.D. 1884, 11th *February*. No. 1384.

IMPROVEMENTS IN THE CONSTRUCTION OF SHIPS.

LETTERS OF REGISTRATION to William Coppin and Emélie Alexander, for
an Improvement in the Construction of Ships.

[Registered on the 11th day of February, 1884, in pursuance of the Act 16 Vic. No. 24.]

BY HIS EXCELLENCY THE RIGHT HONORABLE SIR AUGUSTUS WILLIAM FREDERICK SPENCER LOFTUS
(commonly called LORD AUGUSTUS LOFTUS), Knight Grand Cross of the Most Honorable Order of
the Bath, a Member of Her Majesty's Most Honorable Privy Council, Governor and Commander-in-
Chief of the Colony of New South Wales and its Dependencies.

TO ALL TO WHOM THESE PRESENTS SHALL COME, greeting :

WHEREAS WILLIAM COPPIN, of London, in England, and EMÉLIE ALEXANDER, wife of JAMES ALEXANDER, of Sydney, in the Colony of New South Wales, have by their Petition humbly represented to me that the said William Coppin is the author or designer of a certain invention or improvement in manufactures, that is to say, of an invention entitled "Improvements in the Construction of Ships," which is more particularly described in the specification and the sheet of drawings which are hereunto annexed ; and that the said Emélie Alexander is the assignee of a moiety in the said invention, so far as the Colony of New South Wales is concerned ; and that they, the said Petitioners, have deposited with the Honorable the Treasurer of the said Colony of New South Wales the sum of Twenty Pounds sterling, for defraying the expense of granting these Letters of Registration, as required by the Act of Council, sixteenth Victoria, number twenty-four ; and have humbly prayed that I would be pleased to grant Letters of Registration, whereby the exclusive enjoyment and advantage of the said invention or improvement might be secured to them for a period of fourteen years : And I, being willing to give encouragement to all inventions and improvements in the arts or manufactures which may be for the public good, and having received a report favourable to the prayer of the said Petition, from competent persons appointed by me to examine and consider the matters stated therein and to report thereon for my information, am pleased, with the advice of the Executive Council, and in exercise of the power and authority given to me by the said Act of Council, to grant, and do by these Letters of Registration grant unto the said William Coppin and Emélie Alexander, their executors, administrators, and assigns, the exclusive enjoyment and advantage of the said invention or improvement, for and during the term of fourteen years from the date hereof ; to have, hold, and exercise unto the said William Coppin and Emélie Alexander, their executors, administrators, and assigns, the exclusive enjoyment and advantage thereof, for and during and unto the full end and term of fourteen years from the date of these presents next and immediately ensuing, and fully to be complete and ended : Provided always, that if the said William Coppin and Emélie Alexander, shall not within three days after the granting of these Letters of Registration, register the same in the proper office in the Supreme Court, at Sydney, in the said Colony of New South Wales, then these Letters of Registration, and all advantages whatsoever hereby granted, shall cease and become void.

In witness whereof, I have hereunto set my sign manual, and have caused the present Letters of Registration to be sealed with the seal of the said Colony of New South Wales, at Government House, Sydney, in New South Wales, this eleventh day of February, in the year of our Lord one thousand eight hundred and eighty-four.

[L.S.]

AUGUSTUS LOFTUS.

Improvements in the Construction of Ships.

SPECIFICATION OF WILLIAM COPPIN, of London, in England, for an invention entitled "Improvements in the Construction of Ships."

My improvement relates to ships for ocean and river navigation, and to ships of war, and has for its object to secure a greater speed, stability, and safety.

The invention consists in a compound ship composed of three ship hulls united as one vessel, the two outer hulls being longer than the central hull, and the whole being decked over all as hereinafter described.

Reference is to be had to the accompanying drawing forming part of this specification, in which similar letters of reference indicate corresponding parts in all the figures.

Figure 1 is a side elevation of a ship of my improved construction; figure 2 is a sectional plan view; and figure 3 is a transverse section.

A A are the outer hulls of narrow beam and of equal length, and B a hull much shorter and placed in the centre space between the two longer vessels. The three hulls are rigidly connected by iron or steel bulk-heads, box-girders, iron or steel decks or frames, in such a way as to form complete platforms or decks *a*, and so as to leave considerable extra space between the ships. The centre ship B is to carry the engines, and is provided with a propeller *b* at each end. This arrangement brings the screws well toward the centre of the long or outside ships, and prevents the possibility of the pitching motion lifting the propeller out of the water, and endangering the machinery, as is the case now with long ships of the usual build. All three hulls are tapered from the centre, both vertically and longitudinally, and come to a rounded point at both ends, so as to enter the wave, and so reduce the pitching motion to a minimum, the rolling motion being done away with by the extent of water-spaces between the ships. The platforms or decks extend to about three-fifths (more or less) of the whole length of the outside ships in the centre, and the remaining portion of the ends forward and aft are covered over for passing through the waves; but the space between is not decked over. In ships of this construction, for smooth water or river purposes, I would carry, by preference, the decks the entire length of the outside ships, nearly horizontal, and in these cases the vessel may be propelled by either a screw or paddle-wheel.

My improved construction is specially applicable to warships, and enable a large amount of armour-plating to be carried, owing to increased stability. They give extended battery-platform to carry guns of the largest calibre, and turrets of increased thickness of armour-plate can be employed with safety. Complete protection is also given to engine, screw, propeller, and steering apparatus; increased accommodation for a large number of troops and horses, with a speed of at least one-third faster than the present class of transports; and the construction is such that one of the three ships might be completely riddled with shot or damaged by a ram and yet be supported by the other two. The light draft of water gives greater facilities for manœuvring, and for entering harbours.

The two outer vessels A are provided with rudders *c*, at the inner side, and in line with the ends of the inner ship. The three ships will be divided into water-tight compartments.

Having thus described my invention, I claim as new, and desire to secure by Letters of Registration—

The compound ship, constructed substantially as shown and described, of three hulls of narrow beam, the two outer hulls being longer than the central hull, and the whole decked over and combined as one vessel.

In witness whereof, I, the said William Coppin, have hereto set my hand and seal, this fifteenth day of August, one thousand eight hundred and eighty-three.

WILLIAM COPPIN.

(By his Attorney, JAMES ALEXANDER.)

Witness—

FRED. WALSH,

Manager, Edward Waters' Patent Office, Sydney.

This is the specification referred to in the annexed Letters of Registration granted to William Coppin and Emélie Alexander, this eleventh day of February, A.D. 1884.

AUGUSTUS LOFTUS.

REPORT.

Sir,

Sydney, 22 August, 1883.

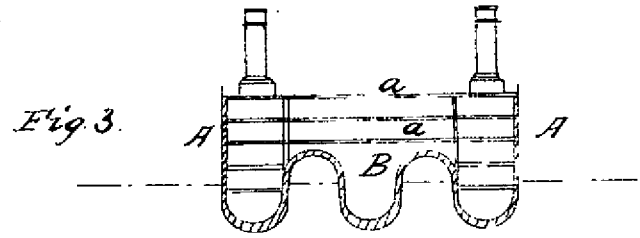
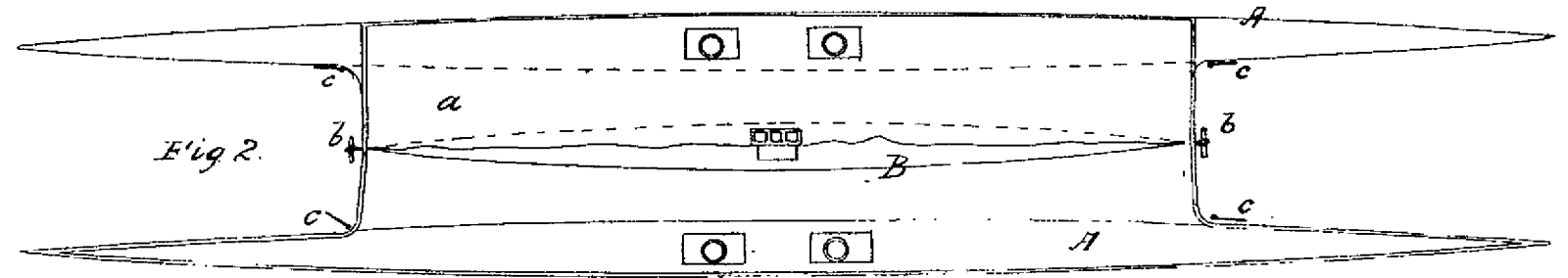
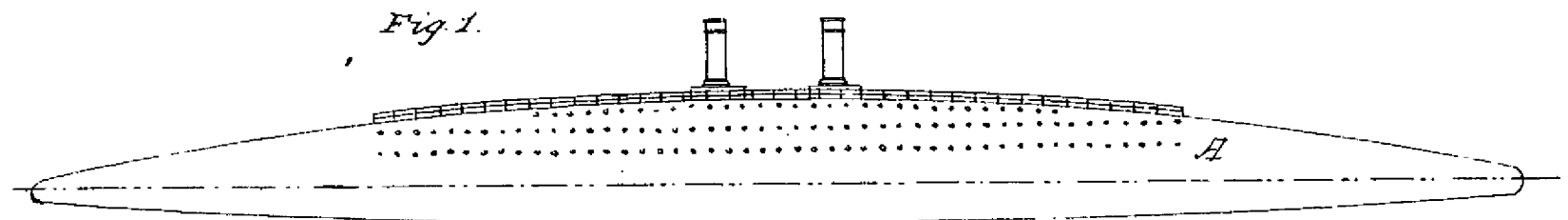
In reply to your letter of the 15th instant, we have the honor to state that we have examined the application of William Coppin and Emélie Alexander, for Letters of Registration for an invention entitled "Improvements in the Construction of Ships," and also the plan and specification therewith, and see no reason why their application should not be granted.

We have, &c.,

FRANCIS HIXSON.
H. BRODERICK.

The Under Secretary of Justice.

W. Coppin's Patent



(Sig. 245.-)

*This is the Sheet of Drawings referred to in the annexed
 Letters of Registration granted to William Coppin, and
 Emelie Alexander, this eleventh day of February, A.D. 1884.*

Augustus Loftus.



A.D. 1884, 13th February, No. 1385.

IMPROVEMENTS IN WINDMILLS.

LETTERS OF REGISTRATION to William Snead, for Improvements in Windmills.

[Registered on the 13th day of February, 1884, in pursuance of the Act 16 Vic. No 24.]

BY HIS EXCELLENCY THE RIGHT HONORABLE SIR AUGUSTUS WILLIAM FREDERICK SPENCER LOFTUS (commonly called LORD AUGUSTUS LOFTUS), Knight Grand Cross of the Most Honorable Order of the Bath, a Member of Her Majesty's Most Honorable Privy Council, Governor and Commander-in-Chief of the Colony of New South Wales and its Dependencies.

TO ALL TO WHOM THESE PRESENTS SHALL COME, greeting :

WHEREAS WILLIAM SNEAD, of Echuca, in the Colony of Victoria, watchmaker, hath by his Petition humbly represented to me that he is the author or designer of a certain invention or improvement in manufactures, that is to say, of an invention entitled "Improvements in Windmills," which is more particularly described in the specification and the sheet of drawings which are hereunto annexed ; and that he, the said Petitioner, hath deposited with the Honorable the Treasurer of the said Colony of New South Wales the sum of Twenty Pounds sterling, for defraying the expense of granting these Letters of Registration, as required by the Act of Council, sixteenth Victoria, number twenty-four ; and hath humbly prayed that I would be pleased to grant Letters of Registration, whereby the exclusive enjoyment and advantage of the said invention or improvement might be secured to him for a period of fourteen years : And I, being willing to give encouragement to all inventions and improvements in the arts or manufactures which may be for the public good, and having received a report favourable to the prayer of the said Petition, from competent persons appointed by me to examine and consider the matters stated therein and to report thereon for my information, am pleased, with the advice of the Executive Council, and in exercise of the power and authority given to me by the said Act of Council, to grant, and do by these Letters of Registration grant unto the said William Snead, his executors, administrators, and assigns, the exclusive enjoyment and advantage of the said invention or improvement, for and during the term of fourteen years from the date hereof ; to have, hold, and exercise unto the said William Snead, his executors, administrators, and assigns, the exclusive enjoyment and advantage thereof, for and during and unto the full end and term of fourteen years from the date of these presents next and immediately ensuing, and fully to be complete and ended : Provided always, that if the said William Snead shall not, within three days after the granting of these Letters of Registration, register the same in the proper office in the Supreme Court, at Sydney, in the said Colony of New South Wales, then these Letters of Registration, and all advantages whatsoever hereby granted, shall cease and become void.

In witness whereof, I have hereunto set my sign manual, and have caused the present Letters of Registration to be sealed with the seal of the said Colony of New South Wales, at Government House, Sydney, in New South Wales, this thirteenth day of February, in the year of our Lord one thousand eight hundred and eighty-four.

[L.S.]

AUGUSTUS LOFTUS.

Improvements in Windmills.

SPECIFICATION of WILLIAM SNEAD, of Echuca, in the Colony of Victoria, watchmaker, for an invention entitled "Improvements in Windmills."

My improvements in windmills have been designed for the purpose of providing a means whereby the wind-wheel is automatically thrown out of gear and allowed to revolve independently on its axle when the wind rises to a greater force than is desired. It consists in placing in front of the wind-wheel a clutch coupling, the one half of which is fixed to the shaft, and the other half attached to the boss of the wind-wheel by means of a helical spring. At the back of the wind-wheel is another boss, which works against a fixed collar on said shaft. This boss has arms springing therefrom corresponding in number and position to the arms of the wind-wheel, to the end of which, or between them if so preferred, are fixed springs which force these two sets of arms apart, thereby retaining the clutch couplings in gear until such time as the wind compresses them together, when the clutch couplings become detached and allow the wind-wheel to revolve freely without doing any work.

Referring to the drawings, figure 1 shows so much of a windmill as is necessary to illustrate my invention, the two halves of the clutch being out of gear, and the springs between the two sets of arms being of the form which I prefer. Figure 2 shows similar view, with the two halves of the clutch in gear. In this view I have also shown four alternative forms of springs, 1, 2, 3, and 4, which may be used instead of those shown in figure 1; and figures 3 and 4 show an alternative method of applying my invention, in which the helical spring C for connecting the loose half of the clutch to the boss of the wind-wheel is dispensed with, and such loose half forms part of the boss of the wind-wheel.

In these figures A is the boss of the wind-wheel, having arms A¹ affixed thereto. This boss is loose on its shaft A², and in front of it is a clutch coupling, the one half of which B is affixed to it by means of the helical spring C, and the other half B¹ is a fixture on the shaft A². At the back of the wind-wheel is a second boss D having arms D¹ and springs D². This boss also works loose on the shaft A² against the fixed collar A³. The helical spring C is fixed to the boss A and clutch B at its ends B² and B³, thereby forming the medium through which the power is transmitted from said wind-wheel boss to the fixed half of clutch B¹, and through it to the shaft A². This spring is not absolutely necessary, as the boss and loose half of clutch may be fixtures to one another, or the jaws cast on the wind-wheel boss, as shown in figures 3 and 4, but the spring is desirable, as it relieves the machinery of the jar consequent upon the clutches coming suddenly into gear.

Any kind of springs may be used at the back of the wind-wheel, and the loose half of clutch may be connected to the boss of same by a spring, or the jaws may be made part of or a fixture to said boss of wind-wheel, as desired, without departing from the nature of my invention; but what I believe to be new, and therefore claim as my improvements in windmills, is—

First—The construction of windmills with one half of a clutch fixed to the driving shaft, and the other half attached to or forming part of the boss of the wind-wheel, which wind-wheel is pressed forward by springs, so that when the pressure of the wind exceeds that of said springs it is pressed backwards, and the two halves of the clutch thereby disconnected or thrown out of gear, substantially as herein described and explained.

Second—Attaching the loose half of the clutch by a helical or other spring to the boss of the wind-wheel, as shown in figures 1 and 2, or rigidly, as in figures 3 and 4.

In witness whereof, I, the said William Snead, have hereto set my hand and seal, this twenty-eighth day of November, one thousand eight hundred and eighty-three.

WILLIAM SNEAD.

This is the specification referred to in the annexed Letters of Registration granted to William Snead, this thirteenth day of February, A.D. 1884.

AUGUSTUS LOFTUS.

REPORT.

Sir,

Sydney, 12 December, 1883.

In reply to your B.C. of the 4th instant, submitting a Petition for Letters of Registration from Mr. William Snead, of Echuca, for an invention entitled "Improvements in Windmills," we have the honor to state that, having examined the plan and specification accompanying the Petition, we are of opinion that the prayer of the Petitioner should be acceded to.

We have, &c.,

JOHN WHITTON.
E. O. MORIARTY.

The Under Secretary of Justice.

W. SNEAD'S PATENT

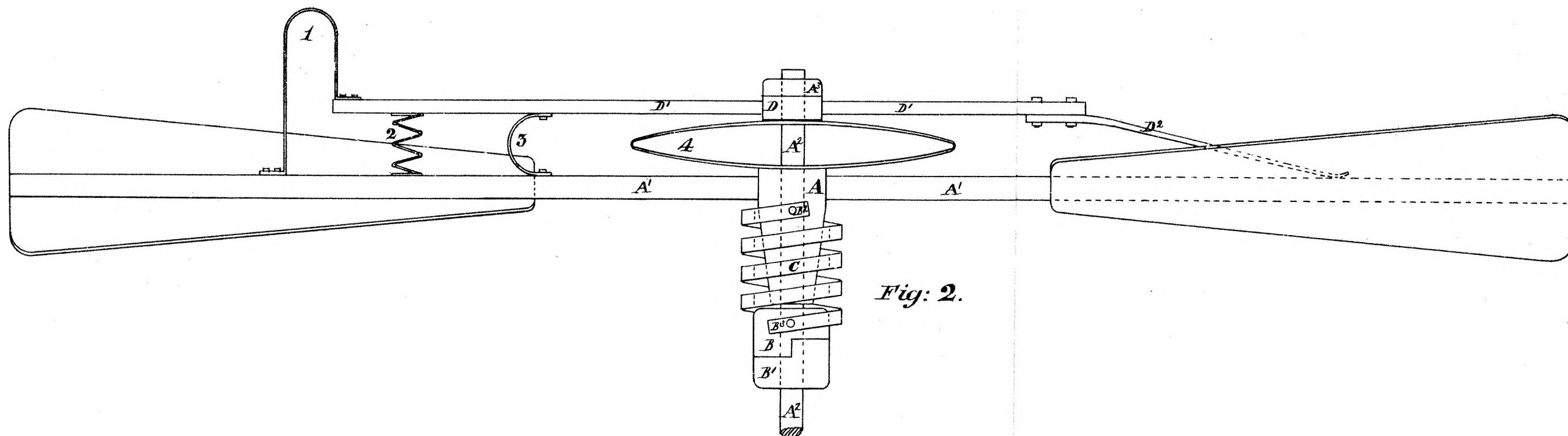


Fig: 2.

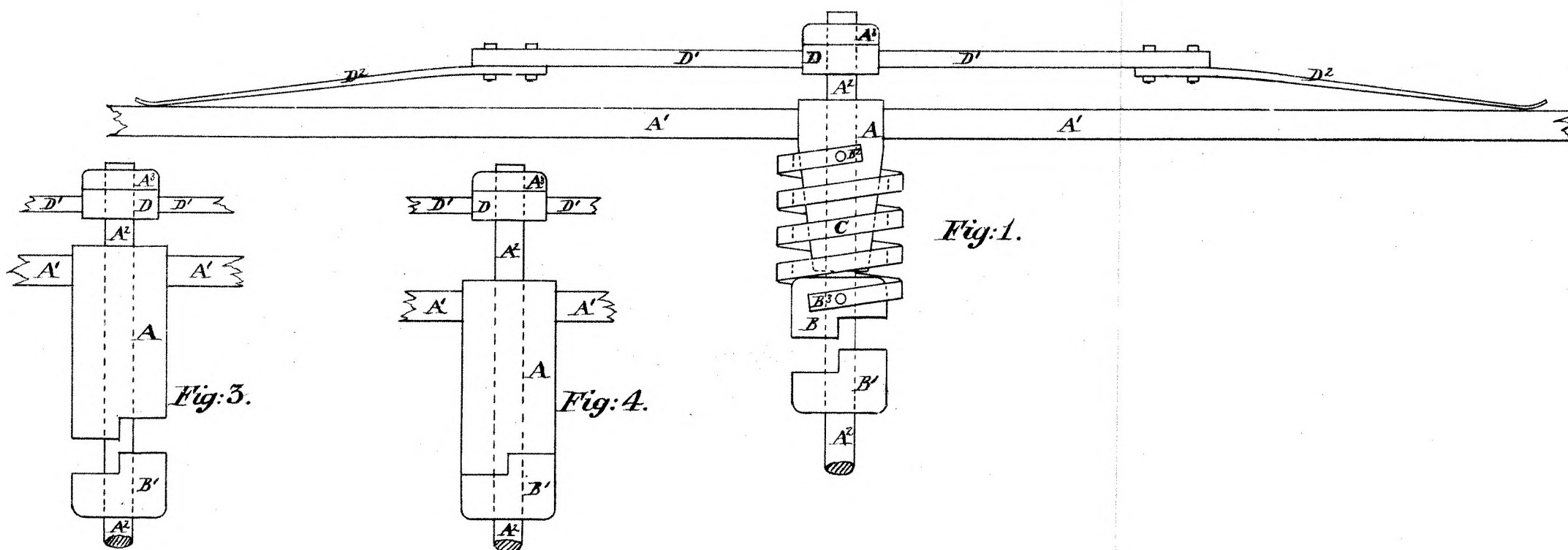


Fig: 1.

Fig: 3.

Fig: 4.

This is the Sheet of Drawings referred to in the annexed Letters of Registration granted to William Snead, this thirteenth day of February, A.D. 1884.

Augustus Loftus.

PHOTO-LITHOGRAPHED AT THE GOVT. PRINTING OFFICE, SYDNEY, NEW SOUTH WALES.

(Sig. 245-)



A.D. 1884, 13th February. No. 1386.

IMPROVEMENTS IN CONSTRUCTION AND ARRANGEMENTS OF ELECTRO-MAGNETS.

LETTERS OF REGISTRATION to Stanley Charles Cuthbert Currie, for Improvements in the construction and arrangements of the Cores and Armatures and other parts of the Electro-magnets.

[Registered on the 13th day of February, 1884, in pursuance of the Act 16 Vic. No. 24.]

BY HIS EXCELLENCY THE RIGHT HONORABLE SIR AUGUSTUS WILLIAM FREDERICK SPENCER LOFTUS (commonly called LORD AUGUSTUS LOFTUS), Knight Grand Cross of the Most Honorable Order of the Bath, a Member of Her Majesty's Most Honorable Privy Council, Governor and Commander-in-Chief of the Colony of New South Wales and its Dependencies.

TO ALL TO WHOM THESE PRESENTS SHALL COME, greeting :

WHEREAS STANLEY CHARLES CUTHBERT CURRIE, of 22, Clarges-street, Piccadilly, in the county of Middlesex, England, gentleman, hath by his Petition humbly represented to me that he is the author or designer of a certain invention or improvement in manufactures, that is to say, of an invention entitled "Improvements in the construction and arrangements of the Cores and Armatures and other parts of the Electro-magnets," which is more particularly described in the specification and the sheet of drawings which are herewith annexed ; and that he, the said Petitioner, hath deposited with the Honorable the Treasurer of the said Colony of New South Wales the sum of Twenty Pounds sterling, for defraying the expense of granting these Letters of Registration, as required by the Act of Council, sixteenth Victoria, number twenty-four ; and hath humbly prayed that I would be pleased to grant Letters of Registration, whereby the exclusive enjoyment and advantage of the said invention or improvement might be secured to him for a period of fourteen years : And I, being willing to give encouragement to all inventions and improvements in the arts or manufactures which may be for the public good, and having received a report favourable to the prayer of the said Petition, from competent persons appointed by me to examine and consider the matters stated therein and to report thereon for my information, am pleased, with the advice of the Executive Council, and in exercise of the power and authority given to me by the said Act of Council, to grant, and do by these Letters of Registration grant unto the said Stanley Charles Cuthbert Currie, his executors, administrators, and assigns, the exclusive enjoyment and advantage of the said invention or improvement, for and during the term of fourteen years from the date hereof ; to have, hold, and exercise unto the said Stanley Charles Cuthbert Currie, his executors, administrators, and assigns, the exclusive enjoyment and advantage thereof, for and during and unto the full end and term of fourteen years from the date of these presents next and immediately ensuing, and fully to be complete and ended : Provided always, that if the said Stanley Charles Cuthbert Currie shall not, within three days after the granting of these Letters of Registration, register the same in the proper office in the Supreme Court, at Sydney, in the said Colony of New South Wales, then these Letters of Registration, and all advantages whatsoever hereby granted, shall cease and become void.

In witness whereof, I have herewith set my sign manual, and have caused the present Letters of Registration to be sealed with the seal of the said Colony of New South Wales, at Government House, Sydney, in New South Wales, this thirteenth day of February, in the year of our Lord one thousand eight hundred and eighty-four.

[L.S.]

AUGUSTUS LOFTUS.

Improvements in construction and arrangements of Electro-magnets.

SPECIFICATION of STANLEY CHARLES CUTHBERT CURRIE, of 22, Clarges-street, Piccadilly, in the county of Middlesex, England, gentleman, for an invention entitled "Improvements in the construction and arrangements of the Cores and Armatures and other parts of Electro-magnets."

THE objects of this invention are to provide electro-magnets that shall have a maximum of power with a minimum of resistance and cost. A great want in electro-magnets is to get a magnet which, with a small current, shall utilize the greatest portion of that current by having a small resistance with a maximum of induction and a large magnetic field. If these ends are attained a number of electro-magnets may be placed in series over a long length of conducting wire, and supposing the magnets to be used for the purposes of providing means for pulling levers, a continuous current of small power can be transmitted, and a pull of great force given to each magnet at a small cost. The pull will not only be a powerful one, but will have a long stroke. The further objects are not only to provide electro-magnets with a strong long-stroke pull for working railway-signal levers, but also to provide the strongest and most economical electro-magnets for any purposes where they are useful, such, for instance, as working railway brakes either alone or in conjunction with some mechanical means, turning valves or cocks, and also for use in series of two, three, or more as a motor, and for many other purposes.

With these objects in view I make an inner cylindrical core of soft iron of any suitable thickness, diameter, and length, and at any suitable distance outside it I put another cylinder of the same length, or any other suitable length, and of such a thickness that the ratio of the sectional areas may be such that the magnetic influence of the two shall be equal. These two cylinders rest upon a circular soft iron plate, or one or both the cylinders may project to the bottom of the plate. The space between the inner and outer cylinder before described is filled in with one or more coils of wire. Each coil may consist of one or more strands of wire separately insulated, and the wires or combination of wires may be so arranged with switches and connections that one system or any number may be used at once, according to the resistance required or work to be done. At one or both ends, if necessary, I put a disc of brass or other diamagnetic substance to keep the coils in place.

The reasons for putting a cylinder outside the coil or coils, as well as inside, is that both are magnetized by the one coil and further strengthened by their opposite poles being connected by the circular plate on which they rest, the plate itself also being acted upon by the current in coil.

Within the inner core or cylinder I put a rod of any suitable size or length of soft iron encased in brass or other diamagnetic substance (to prevent it sticking to the inner cylinder), so that it slides easily, but not too loosely or too tightly, therein; and the iron may or may not extend the whole length of the brass casing, and it may be graduated or stepped, hollow or cone shaped, or of any other convenient shape. This rod is screwed or fastened to or made a part of and the same piece with a circular plate of soft iron, which is, of course, at the opposite end of the magnet to the circular soft iron plate hereinbefore mentioned, and the whole acts as an armature.

The object of this centre rod of iron encased in brass or other diamagnetic substance sliding within the inner cylinder is that, being acted upon by the current in coil and polarised longitudinally thereby, it polarises the circular plate to which it is attached radially, and in such a way that the attraction is between the plate (which acts as an armature) and the outer cylinder, thus increasing the total pull on the armature.

Round the outside of the circular plate which is attached to the centre rod I put one or more rims of iron or other suitable metal of such a depth as to project round the plate towards the outer cylinder (though it may be made to project towards one of the other cylinders) above mentioned, and is by preference of such a diameter that it will just slip over the latter without touching it. This rim may have a plain, rough, wavy, notched, serrated, or tapering edge, the object of which is that its edge is nearer the cylinder than is the plate to which it is attached to that cylinder, and it is therefore drawn towards the latter, and thereby brings the plate with it until it (the plate) is acted upon by the cylinders, and hence the total pull is lengthened. Of course the size, depth, shape, and quality of the rim depend upon the nature of pull required. This outer rim may be attached directly to the circular plate, or with a thin ring of brass or other diamagnetic substance between, this depending upon the strength and distribution of pull required. Of course the ring may consist of one or more pieces or sheets of metal with or without diamagnetic layers between them, and the different rings or rims (of which there may be any convenient number) may be of different depths and shapes.

Instead of soft iron, as hereinbefore described, soft steel or other suitable metal may be used, because I would remark that it is possible to make a metal other than iron which, when magnetized, can be quickly demagnetised; and where one sheet or ring of metal is described herein the sheet or ring may be made of one, two, or more pieces or sheets of iron or other suitable metal without interfering with the objects of this invention.

DESCRIPTION OF THE DRAWINGS.

Figure 1 is a half elevation of an electro-magnet, in which the said invention is embodied. Figure 2 is a half vertical section of the same, *a* is the inner cylindrical core of soft iron or soft steel or any other suitable metal made of any convenient thickness, diameter, or length, on the outside of which is another cylinder *b* of the same length or any other convenient length, and of such a thickness that the ratio of the sectional area of the one to the sectional area of the other may be such that the magnetic influence of the two shall be equal the one to the other. The two cores rest on a soft iron plate *c*, and either or both of them may project to the bottom of the plate. The space between the inner and outer cores is filled up with insulated wire *d* of one or more systems (but only represented as one system in figure 2 of the drawings) according for what purpose the magnet is required. *e* is a disc of brass used to keep the coils of wire *d* in their place when coiling. Within the inner core or cylinder a rod *f* of any suitable size, as shown in figure 2, encased wholly or partly by brass or other diamagnetic substance *g*, is made to work. When convenient I make the rod or some other part of the armature when it comes home against the bobbin put the wires of helix in series by means of a suitable switch, whereby the resistance of the magnet is increased when the armature is home, and thereby a smaller current is required to hold it in that position, and a consequent saving in electrical power in cases where the armature has to be held home for some time.

The rod *f* is screwed to the circular plate *i* by the screw *m*, or it can be made a part of the plate *i*,

Improvements in construction and arrangements of Electro-magnets.

or fastened in any other convenient way. Round the circular plate which acts as the top part of the armature is a thin rim made of iron or other suitable metal *n*. This rim may have a plain or notched or uneven edge, as shown in figures 5 and 6, for the purpose of illustration, but it must be understood that I do not confine myself to any particular shape. This rim *n* may be attached to the circular plate directly, or it can be screwed thereto, and it may be slotted to allow of adjustment, and there may be two or more rims of any convenient shape and size (see *o* and *p*).

Figure 3 represents a plan of top of armature, and figure 4 a plan of top of bobbin.

Having now described the nature of the said invention, and the manner in which the same is to or may be carried into effect, I claim—

First—The combination of the outer cylinder together with the inner cylindrical core, both fastened to the bottom plate, and one or more systems of insulated wire in order to get a maximum of magnetic induced force with the smallest resistance, substantially as and for the purposes hereinbefore described.

Second—The rim or rims, plain or wavy, or notched, or other uneven form, fastened to the outer circumference of the armature plate, together with the centre rod encased wholly or partly in brass or other suitable diamagnetic substance fastened to the centre of same, substantially as and for the purposes hereinbefore described.

In witness whereof, I, the said Stanley Charles Cuthbert Currie, have hereto set my hand and seal, this second day of November, in the year of our Lord one thousand eight hundred and eighty-three.

STANLEY C. C. CURRIE.

This is the specification referred to in the annexed Letters of Registration granted to Stanley Charles Cuthbert Currie, this thirteenth day of February, A.D. 1884.

AUGUSTUS LOFTUS.

REPORT.

Sir,

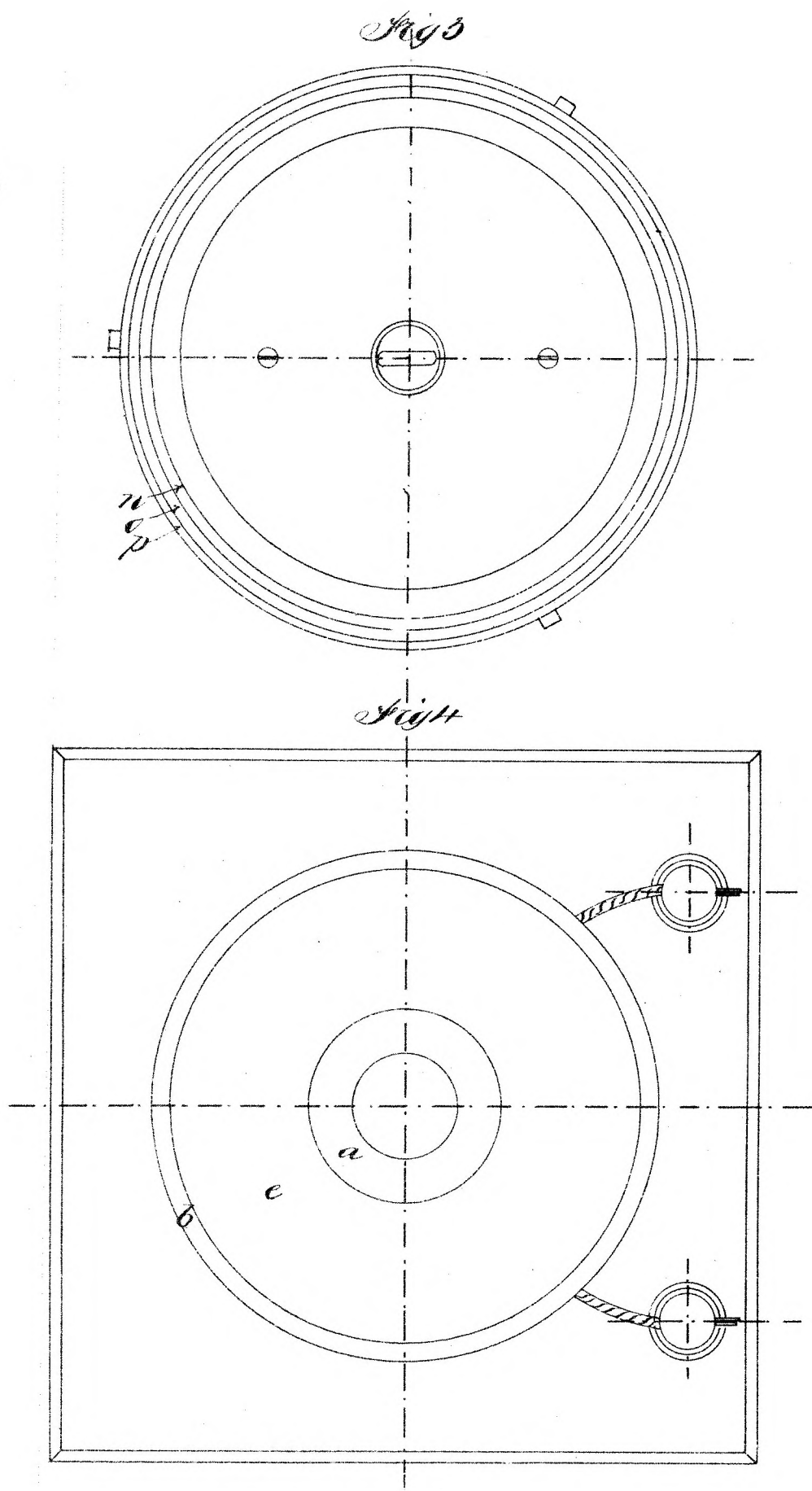
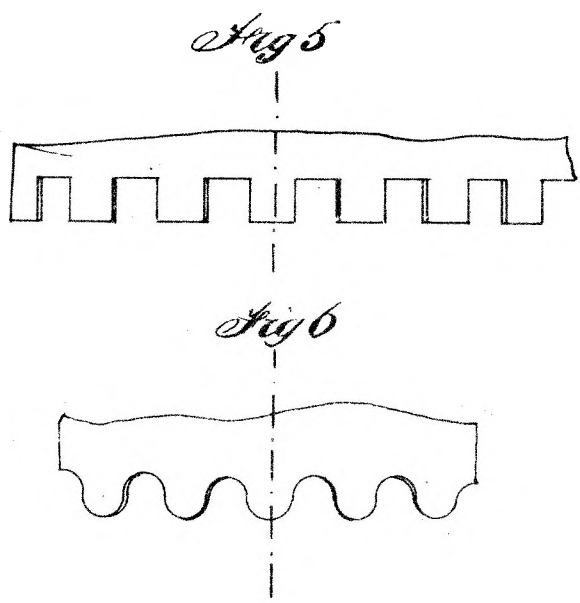
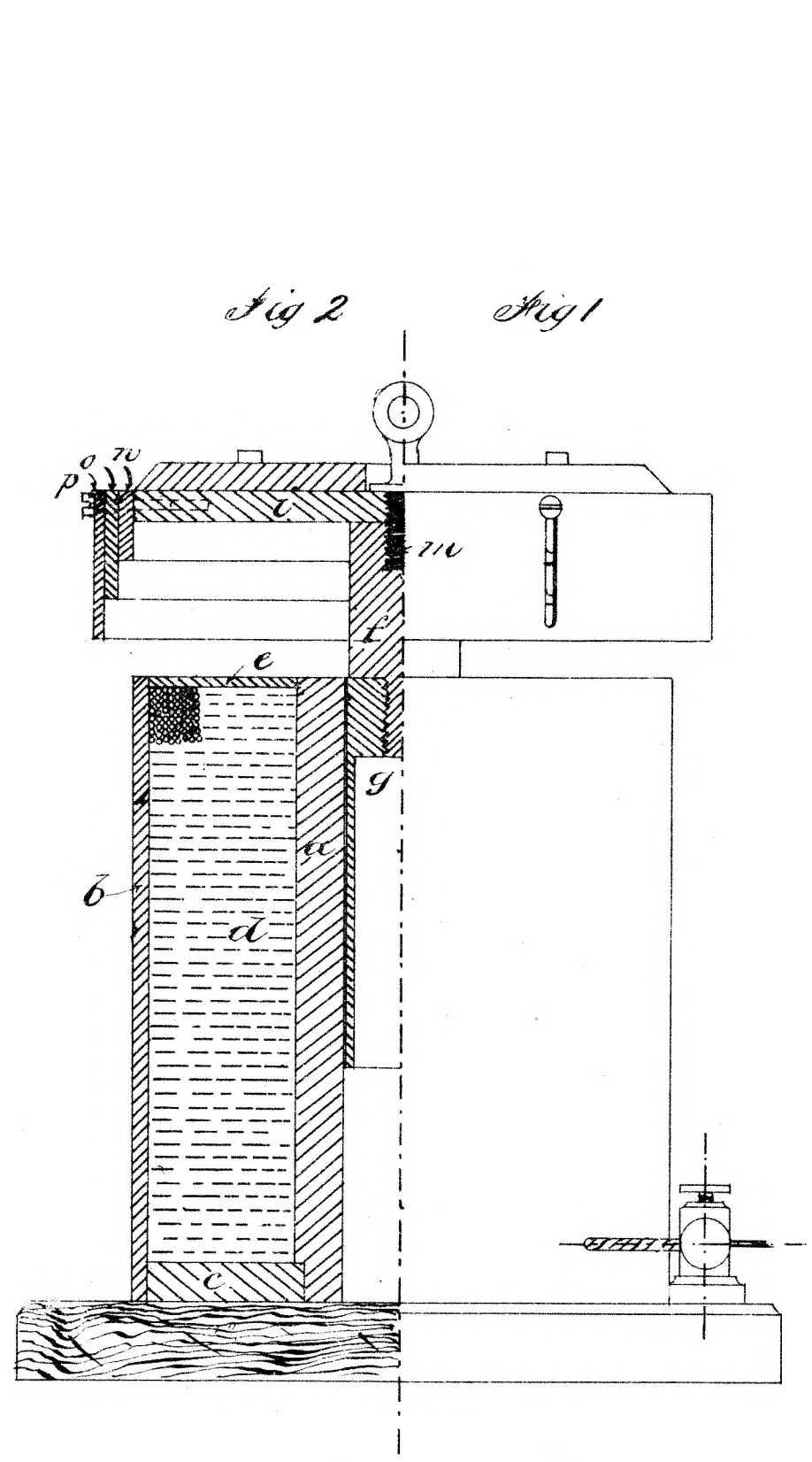
Sydney, 31 December, 1883.

We do ourselves the honor to report, in reply to your blank cover of the 17th December, No. 14,708, transmitting Mr. Stanley Charles Cuthbert Currie's Petition for the registration of an invention entitled "Improvements in the construction and arrangements of the Cores and Armatures and other parts of Electro-magnets," that we are of opinion the prayer of the petitioner may be granted, in terms of his specification, drawings, and claim.

We have, &c.,
E. C. CRACKNELL,
GOTHEB K. MANN.

The Under Secretary of Justice.

[Drawings—one sheet.]



This is the Sheet of Drawings referred to in the annexed Letters of Registration granted to Stanley Charles Cuthbert Currie, this thirteenth day of February, AD 1884.
Augustus Loftus.

(Sig. 245-)

Stanley Currie



A.D. 1884, 13th *February*. No. 1387.

AN IMPROVED REGISTERING DEVICE.

LETTERS OF REGISTRATION to Gustave Sueur, for an Improved Registering Device.

[Registered on the 13th day of February, 1884, in pursuance of the Act 16 Vic. No. 24.]

BY HIS EXCELLENCY THE RIGHT HONORABLE SIR AUGUSTUS WILLIAM FREDERICK SPENCER LOFTUS (commonly called LORD AUGUSTUS LOFTUS), Knight Grand Cross of the Most Honorable Order of the Bath, a Member of Her Majesty's Most Honorable Privy Council, Governor and Commander-in-Chief of the Colony of New South Wales and its Dependencies.

TO ALL TO WHOM THESE PRESENTS SHALL COME, greeting :

WHEREAS GUSTAVE SUEUR, of 62, Little Collins-street East, in the City of Melbourne, and Colony of Victoria, watchmaker, hath by his Petition humbly represented to me that he is the author or designer of a certain invention or improvement in manufactures, that is to say, of an invention entitled "An Improved Registering Device," which is more particularly described in the amended specification and the sheet of drawings which are hereunto annexed ; and that he the said Petitioner hath deposited with the Honorable the Treasurer of the said Colony of New South Wales the sum of Twenty Pounds sterling, for defraying the expense of granting these Letters of Registration, as required by the Act of Council, sixteenth Victoria, number twenty-four ; and hath humbly prayed that I would be pleased to grant Letters of Registration, whereby the exclusive enjoyment and advantage of the said invention or improvement might be secured to him for a period of fourteen years : And I, being willing to give encouragement to all inventions and improvements in the arts or manufactures which may be for the public good, and having received a report favourable to the prayer of the said Petition, from competent persons appointed by me to examine and consider the matters stated therein and to report thereon for my information, am pleased, with the advice of the Executive Council, and in exercise of the power and authority given to me by the said Act of Council, to grant, and do by these Letters of Registration grant unto the said Gustave Sueur, his executors, administrators, and assigns, the exclusive enjoyment and advantage of the said invention or improvement, for and during the term of fourteen years from the date hereof ; to have, hold, and exercise unto the said Gustave Sueur, his executors, administrators, and assigns, the exclusive enjoyment and advantage thereof, for and during and unto the full end and term of fourteen years from the date of these presents next and immediately ensuing, and fully to be complete and ended : Provided always, that if the said Gustave Sueur shall not, within three days after the granting of these Letters of Registration, register the same in the proper office in the Supreme Court, at Sydney, in the said Colony of New South Wales, then these Letters of Registration, and all advantages whatsoever hereby granted, shall cease and become void.

In witness whereof, I have hereunto set my sign manual, and have caused the present Letters of Registration to be sealed with the seal of the said Colony of New South Wales, at Government House, Sydney, in New South Wales, this thirteenth day of February, in the year of our Lord one thousand eight hundred and eighty-four.

[L.S.]

AUGUSTUS LOFTUS.

An Improved Registering Device.

SPECIFICATION of GUSTAVE SUEUR, of 63, Little Collins-street East, in the City of Melbourne, and Colony of Victoria, watchmaker, for an invention entitled "An Improved Registering Device."

MY improved registering device has been designed principally as a substitute for the system of tallying in vogue at present, which consists in cutting a notch in a stick, or using stones, to represent every hundred counted. My device is contained preferably in an ordinary watch-case, and consists of a ratchet wheel with ten teeth, each tooth representing a number, the first being 1, and so on to 10, each unit representing a hundred, or any other denominator. This ratchet wheel is rigidly affixed to a spindle which passes through to the dial plate and terminates in an indicator. On the dial plate are marked the figures 1 to 10, corresponding to the teeth on the ratchet wheel. At the side of, and slightly elevated above, this ratchet wheel, is a star-shaped wheel having eleven teeth, each tooth representing a number, the first being 0, and so on to 10, each number representing a thousand, or just ten times each unit. This star wheel is also rigidly affixed to a spindle which also passes through the dial plate and terminates in an indicator like the other. On the dial plate are marked the figures 0 to 10, corresponding to the teeth on the star wheel. When the person counting has reached a hundred, and wishes to register same, he places his finger on a thumb piece (which occupies the place of the ordinary opening arrangement of watches), which presses on a horizontal bar pivoted at one end, and with an elbow at the other, which in its turn presses down a pawl into one of the teeth of the ratchet wheel, and so revolves it. A spring pawl is provided at the opposite side which prevents the ratchet wheel from revolving backwards more than the one tooth until the thumb piece is again pressed down. On the pressure being withdrawn from the thumb piece a spring attached to the first-named pawl throws it back into position ready for the next registration, said pawl pushing back the horizontal bar to its stop. In order to enable the pawl to return to its position it is necessary to make it hinged, so that it will bend as it is returning. When the ratchet wheel has registered its ten units a pin on its upper face strikes against one of the teeth of the star wheel, whose indicator immediately registers that number, and is prevented from registering again, until the ratchet wheel makes a complete revolution, by means of a pivoted spring pressing against it, said spring being attached to the inner face of the watch-case. A bell or gong may be used to give notice that the device has registered the number desired.

Referring to my drawings, figure 1 shows back view of one of my registering devices with the back removed to show the internal arrangement when at rest. Figures 2 and 3 are similar views (omitting the star wheel and gong) to show the units, wheel, &c., when on the point of registering, and when the hinged pawl is in the act of returning after the completion of its stroke. Figure 4 shows face of device.

A is the thumb piece, by pressing on which the pivoted lever B is forced downwards as in figure 2, carrying with it hinged pawl C, the end of which presses on one of the teeth of the ratchet wheel D, and moves it to the extent of one tooth, when a spring catch E flies into position and prevents said ratchet wheel from returning. As this ratchet moves it presses downward the end of spring hammer F, which strikes the gong G, and so at each registration the gong sounds, and the units wheel is moved one notch as indicated on dial plate at H (see figure 4). When this motion is completed the thumb is withdrawn from A, and the spring C' presses hinged pawl C upward. As it rises it is compelled to bend on its hinges (see figure 3) before it can assume its original position.

Having thus described the nature of my invention, and the manner of performing same, I would have it understood that I do not confine my invention to simply registering hundreds and thousands, as it may be used for counting from units upwards by simply multiplying the contrivances mentioned; but I would have it understood that what I claim as my invention is—

My improved registering device, substantially as herein described and explained, the essence of which consists in the combination of the thumb piece A, pivoted lever B, and hinged pawl C, for giving motion to the ratchet wheel D.

In witness whereof, I, the said Gustave Sueur, have hereto set my hand and seal, this twenty-sixth day of October, one thousand eight hundred and eighty-three.

Witness—

EDWARD WATERS,

Patent Agent, Melbourne.

GUSTAVE SUEUR.

This is the amended specification referred to in the annexed Letters of Registration granted to Gustave Sueur, this thirteenth day of February, A.D. 1884.

AUGUSTUS LOFTUS.

REPORT.

Sir,

We have carefully examined the accompanying application of Mr. Gustave Sueur (83-13,148) for Letters of Registration for "An Improved Registering Device," and consider the Petition may be granted if all the words in the claim after the letter D be left out. (Applicant's agent having acceded to the suggestion of the Board, Letters of Registration were accordingly issued.)

We have, &c.,

E. C. CRACKNELL.

GOTHER K. MANN.

The Under Secretary of Justice.

[Drawings—one sheet.]

SUEUR'S PATENT.

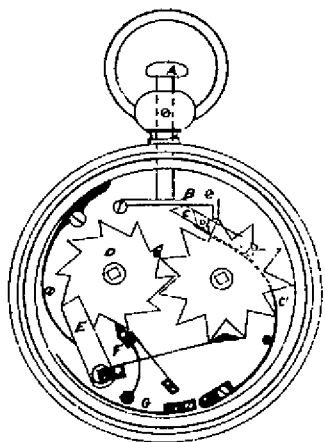


Fig. 1.

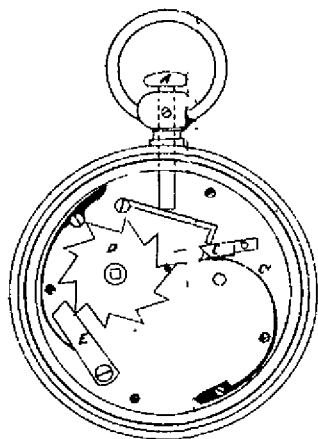


Fig. 2.

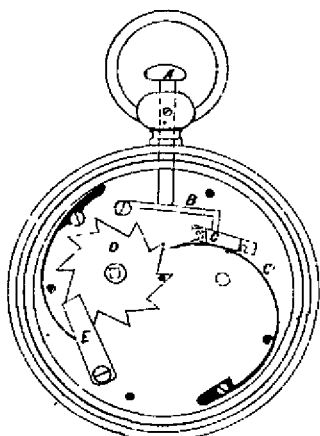


Fig. 3.

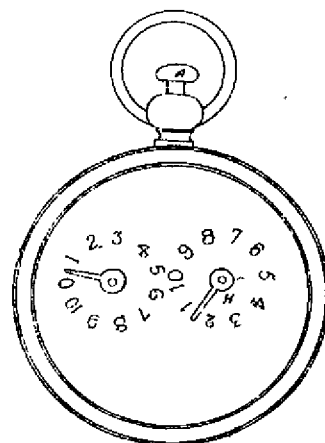


Fig. 4.

This is the Sheet of Drawings referred to in the annexed Letters of Registration granted to Gustave Sueur; this thirteenth day of February, A.D. 1884.

Augustus Loftus.

PHOTO-LITHOGRAPHED AT THE GOVT. PRINTING OFFICE.
SYDNEY, NEW SOUTH WALES.

(Sig. 245.)



A.D. 1884, 13th February. No. 1388.

IMPROVEMENTS IN HYDRAULIC LIFTS.

LETTERS OF REGISTRATION to William Humble Johnson, for Improvements in Hydraulic Lifts.

[Registered on the 13th day of February, 1884, in pursuance of the Act 16 Vic. No. 24.]

BY HIS EXCELLENCY THE RIGHT HONORABLE SIR AUGUSTUS WILLIAM FREDERICK SPENCER LOFTUS (commonly called LORD AUGUSTUS LOFTUS), Knight Grand Cross of the Most Honorable Order of the Bath, a Member of Her Majesty's Most Honorable Privy Council, Governor and Commander-in-Chief of the Colony of New South Wales and its Dependencies.

TO ALL TO WHOM THESE PRESENTS SHALL COME, greeting :

WHEREAS WILLIAM HUMBLE JOHNSON, of Palace Chambers, Westminster, in the county of Middlesex, hath by his Petition humbly represented to me that he is the author or designer of a certain invention or improvement in manufactures, that is to say, of an invention entitled "Improvements in Hydraulic Lifts," which is more particularly described in the specification and the sheet of drawings which are hereunto annexed; and that he, the said Petitioner, hath deposited with the Honorable the Treasurer of the said Colony of New South Wales the sum of Twenty Pounds sterling, for defraying the expense of granting these Letters of Registration, as required by the Act of Council, sixteenth Victoria, number twenty-four; and hath humbly prayed that I would be pleased to grant Letters of Registration, whereby the exclusive enjoyment and advantage of the said invention or improvement might be secured to him for a period of fourteen years: And I, being willing to give encouragement to all inventions and improvements in the arts or manufactures which may be for the public good, and having received a report favourable to the prayer of the said Petition, from competent persons appointed by me to examine and consider the matters stated therein and to report thereon for my information, am pleased, with the advice of the Executive Council, and in exercise of the power and authority given to me by the said Act of Council, to grant, and do by these Letters of Registration grant unto the said William Humble Johnson, his executors, administrators, and assigns, the exclusive enjoyment and advantage of the said invention or improvement, for and during the term of fourteen years from the date hereof; to have, hold, and exercise unto the said William Humble Johnson, his executors, administrators, and assigns, the exclusive enjoyment and advantage thereof, for and during and unto the full end and term of fourteen years from the date of these presents next and immediately ensuing, and fully to be complete and ended: Provided always, that if the said William Humble Johnson shall not, within three days after the granting of these Letters of Registration, register the same in the proper office in the Supreme Court, at Sydney, in the said Colony of New South Wales, then these Letters of Registration, and all advantages whatsoever hereby granted, shall cease and become void.

In witness whereof, I have hereunto set my sign manual, and have caused the present Letters of Registration to be sealed with the seal of the said Colony of New South Wales, at Government House, Sydney, in New South Wales, this thirteenth day of February, in the year of our Lord one thousand eight hundred and eighty-four.

[I.S.]

AUGUSTUS LOFTUS.

Improvements in Hydraulic Lifts.

SPECIFICATION of WILLIAM HUMBLE JOHNSON; of Palace Chambers, Westminster, in the county of Middlesex, for an invention entitled "Improvements in Hydraulic Lifts."

My invention relates to hydraulic lifts in which water-pressure is employed for counterbalancing the weight of the cage and plunger, and for compensating the variation of load resulting from the greater or less protrusion of the plunger, the object which I have in view being to simplify construction, to economise space, and to obtain facilities for erection and for repair, when necessary. For this purpose I make the counterbalancing cylinders and plungers of annular kind, surrounding the lift cylinder and its plunger, so that the whole apparatus is accommodated on one foundation within the space of the lift shaft, and without requiring external pipe connections. The particular arrangements of the counterbalancing cylinders and plungers may be varied to suit various conditions. I will describe several arrangements as examples of the constructions which I adapt, referring to the accompanying drawings which are vertical sections showing in each case part of the lift cylinder A and plunger B with hydraulic balancing apparatus according to my invention.

Figure 1 shows an arrangement that may be used when it is desired to intensify the service pressure, so as to have a greater pressure acting in the lift cylinder. In this case part of the lift cylinder A at $A^1 A^2$ is made of differential area, and on it works an annular plunger C, sufficiently heavy in itself, or loaded sufficiently, to counterbalance the weight of the lift plunger and cage, or any desired portion thereof. The differential space of the plunger C when it is at the extreme of its upstroke has capacity enough to contain all the liquid required to raise the lift plunger B. Passages at *a* make communication between the lift cylinder and the interior of the plunger C. A stationary cylinder D communicates at *d* through a suitable valve box with the accumulator or supply reservoir and with the discharge, and the plunger C works through packing at the bottom of D. On admitting the liquid under pressure to D the plunger C is forced downwards, and, owing to the difference of area of A^1 and A^2 , liquid at increased pressure is forced through *a* from the interior of C into the lift cylinder A, raising the plunger B and the cage.

As, by the descent of C, the column of liquid pressing on it increases proportionally to the ascent of the plunger B, the variation of load due to the greater or less protrusion of B is compensated throughout the stroke. On opening *d* to the discharge the weight of the cage and plunger B causes them to descend, forcing liquid through *a* into C and causing C to rise. In the arrangement shown in figure 2 the hollow plunger C works through packing, not only in the cylinder D, but also in a lower cylinder E communicating at *a* with the lift cylinder A. A passage *c* leading to the interior of C is in constant communication with the accumulator or pressure reservoir, so that, in addition to the weight of C, this pressure acts as counterbalance, *d* being as before in communication with the supply and discharge valve box. Obviously the connections of *c* and *d* may be inverted, *d* being in constant communication with the accumulator, while *c* communicates with the valve box. By a modification of this arrangement, shown in figure 3, a low-pressure supply, constantly communicating with D through *d*, and acting on the enlarged piston area of C, serves, in addition to the weight of C, for counterbalance, the working being effected by supply and discharge through *c*. Figure 4 shows another modification of the arrangement shown in figure 2, the parts, in this case, being so arranged that the cylinder C works on the lift plunger B. In the arrangement shown in figure 5 weights W placed on C serve for counterbalance, the working being effected through the passage *d*. By the arrangement shown in figure 6, C is made of sufficient weight, or is loaded sufficiently, for counterbalance, the working being effected by high-pressure liquid through *d*.

Having thus described the nature of my invention, and in what manner the same is to be performed, I claim in respect of hydraulic lifts in which the weight of the cage and lift plunger is wholly or partly counterbalanced by hydraulic pressure:—

Constructing the counterbalancing and intermediately working cylinders and plungers in annular form, surrounding the lift cylinder, substantially as and for the purposes herein set forth.

Witness—

W. S. BAYSTON,
Patent Law Clerk, Melbourne.

W. H. JOHNSON,
(By his Agent, EDWD. WATERS.)

This is the specification referred to in the annexed Letters of Registration granted to William Humble Johnson, this 13th day of February, A.D. 1884.

AUGUSTUS LOFTUS.

REPORT.

Sir,

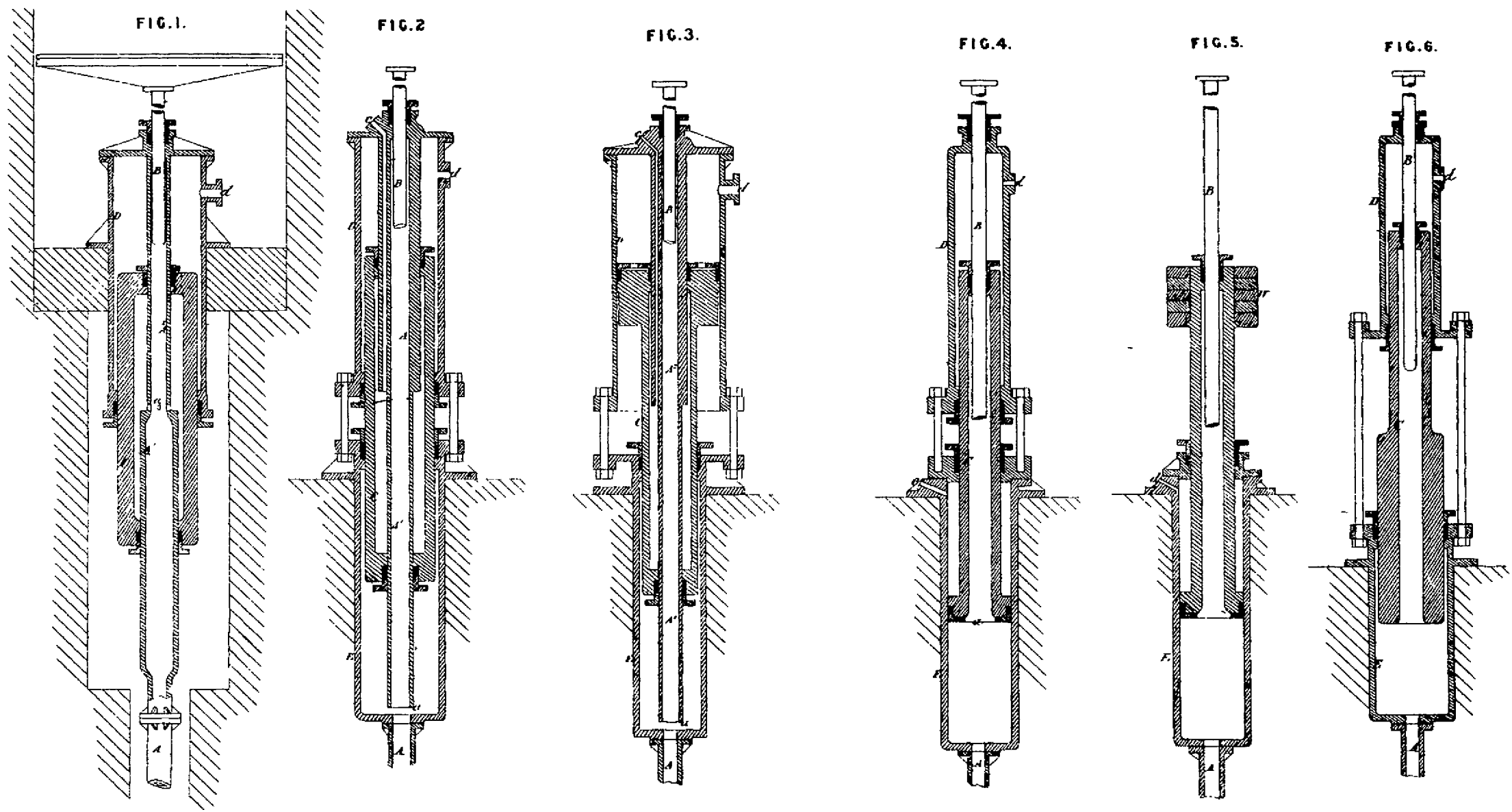
In accordance with your B.C. minute of the 10th instant, forwarding Petition for Letters of Registration for an invention entitled "Improvements in Hydraulic Lifts," the Petitioner being Mr. W. H. Johnson, we have the honor to report that we are of opinion that such Letters should be issued.

We have, &c.,

JAMES BARNET,
WILLIAM C. BENNETT.

The Under Secretary of Justice.

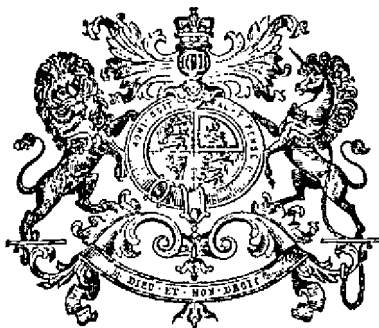
[Drawings—one sheet.]



This is the Sheet of Drawings referred to in the annexed Letters of Registration granted to William Humble Johnson, this thirteenth day of February, A.D. 1884.

(Sig 245-)

Augustus Loftus.



A.D. 1884, 13th February. No. 1389.

IMPROVEMENTS IN AND RELATING TO WHEELS AND AXLES FOR RAILWAY VEHICLES.

LETTERS OF REGISTRATION to Edward B. Orne, for Improvements in and relating to Wheels and Axles for Railway Vehicles.

[Registered on the 13th day of February, 1884, in pursuance of the Act 16 Vic. No. 24.]

BY HIS EXCELLENCY THE RIGHT HONORABLE SIR AUGUSTUS WILLIAM FREDERICK SPENCER LOFTUS (commonly called LORD AUGUSTUS LOFTUS), Knight Grand Cross of the Most Honorable Order of the Bath, a Member of Her Majesty's Most Honorable Privy Council, Governor and Commander-in-Chief of the Colony of New South Wales and its Dependencies.

TO ALL TO WHOM THESE PRESENTS SHALL COME, greeting :

WHEREAS EDWARD B. ORNE, of the City and County of Philadelphia, and State of Pennsylvania in the United States of America, hath by his Petition humbly represented to me that he is the author or designer of a certain invention or improvement in manufactures, that is to say, of an invention entitled "Improvements in and relating to Wheels and Axles for Railway Vehicles," which is more particularly described in the specification and the sheet of drawings which are hereunto annexed; and that he, the said Petitioner, hath deposited with the Honorable the Treasurer of the said Colony of New South Wales the sum of Twenty Pounds sterling, for defraying the expense of granting these Letters of Registration, as required by the Act of Council, sixteenth Victoria, number twenty-four; and hath humbly prayed that I would be pleased to grant Letters of Registration, whereby the exclusive enjoyment and advantage of the said invention or improvement might be secured to him for a period of fourteen years: And I, being willing to give encouragement to all inventions and improvements in the arts or manufactures which may be for the public good, and having received a report favourable to the prayer of the said Petition, from competent persons appointed by me to examine and consider the matters stated therein and to report thereon for my information, am pleased, with the advice of the Executive Council, and in exercise of the power and authority given to me by the said Act of Council, to grant, and do by these Letters of Registration grant unto the said Edward B. Orne, his executors, administrators, and assigns, the exclusive enjoyment and advantage of the said invention or improvement, for and during the term of fourteen years from the date hereof; to have, hold, and exercise unto the said Edward B. Orne, his executors, administrators, and assigns, the exclusive enjoyment and advantage thereof, for and during and unto the full end and term of fourteen years from the date of these presents next and immediately ensuing, and fully to be complete and ended: Provided always, that if the said Edward B. Orne shall not, within three days after the granting of these Letters of Registration, register the same in the proper office in the Supreme Court, at Sydney, in the said Colony of New South Wales, then these Letters of Registration, and all advantages whatsoever hereby granted, shall cease and become void.

In witness whereof, I have hereunto set my sign manual, and have caused the present Letters of Registration to be sealed with the seal of the said Colony of New South Wales, at Government House, Sydney, in New South Wales, this thirteenth day of February, in the year of our Lord one thousand eight hundred and eighty-four.

[L.S.]

AUGUSTUS LOFTUS.

Improvements in Wheels and Axles for Railway Vehicles.

SPECIFICATION of EDWARD B. ORNE, of the City and County of Philadelphia, and State of Pennsylvania, in the United States of America, for an invention entitled "Improvements in and relating to Wheels and Axles for Railway Vehicles."

My invention of improvements in and relating to wheels and axles for railway vehicles consists in providing a hollow axle with rigid collars upon each end, said collars being adapted to retain in position a split bearing, which supports and carries rigidly secured to it the main bearing, which works in the usual axle-box, the said split bearing being clamped by the wheel-hub, and in minor details of construction, all of which are more fully set forth in the following specification, and shown in the accompanying drawings, which form part thereof.

The object of my invention is to facilitate the passage of railroad wheels under cars around curves, and to overcome the resistance occasioned by the circumferential slipping on the rails by the wheels, as is the case with rigid wheels and axles now in general use.

In the drawings, figure 1 is a sectional elevation, on line *xx*, of part of my improvement. Figure 2 is a side elevation of same, looking in a line with the centre of the axle. Figure 3 is an elevation of the centre part of the axle. Figure 4 is a perspective view of one-half of the core or split bearing. Figure 5 is a cross-section of the axle on line *yy*, and figure 6 is an end view of the core.

The wheels *L* may be of any desired pattern, but are made larger at the hub *K*; this extra size of hub being necessary to receive the core or split bearing *E*, which is a cylindrical iron or steel bed, made in two horizontal halves, with edges planed or grooved as at *e'* to fit each other, and which, when placed together, form a round core adapted to be pressed by hydraulic or other power into the hub *K*, the flange or rim *E'* arresting the hub at the proper place. The internal formation of this core *E* is shaped to fit the collars *CJ*, and bodies of hollow axle *A* and end section *I* by being provided with annular grooves *GF* and aperture *H*. The collars *B* and *C* are heated and shrunk on the ends of the hollow axle or centre part *A*, which may be turned up to receive them.

The axle, broadly, is divided into three sections or lengths, comprising one centre part *A*, and two end sections *I*. The hollow centre part *A* is made of wrought iron or steel, and rests in the end of each of the cores *E* in the wheels *L*, and which, with the steel or wrought-iron collars *CB* that are shrunk on it, keep the wheels *L* to gauge and in proper position.

The two iron or steel collars on each end of the axle *A* are arranged, one outside and one inside the core *E*, as shown in figure 1.

There are four small screw-plugs *M* in different parts of the axle *A*, said plugs being arranged equidistant about the circumference of the said axle, and are used to fill the axle with oil, and by their arrangement one of the plugs will always be up.

The ends of the hollow axle *A* are closed by screw-plugs *D*, and inside the screw-plugs and through the pipe forming the axle *A* at each end are bored holes *d* through which the oil flows to lubricate the axle inside the cores *E*.

The end sections *I* of the axle proper are made of steel or wrought iron, and rest in the cores *E*, by which they are firmly clamped, the ends projecting and forming the bearings *i* for the brasses of the axle-boxes, which are the same as are now in general use. These end sections *I* of the axle are firmly secured to the cores *E*, and prevented from turning therein by pins *i'* of sufficient length and size which pass through the outside of the core *E* into the end sections *I*. These pins are put in place before the cores are pressed into the wheel, and therefore when the said cores are in position they cannot work out.

The bearing *i* is lubricated in the same manner as are the bearings in the rigid axle now in general use, and, in addition thereto, a channel *I'* is bored through the centre of each end section *I* of axle, by which oil or other lubricant may pass to lubricate the independent axle *A* inside the core *E*. The inner ends of these end sections *I* are provided with solid collars or flanges *J* which fit into the annular grooves *F* in the cores *E*, and by which they are prevented from working out.

Between the end of the centre section *A* and end sections *I* of axle are steel discs *N*, which are used to prevent any undue wear of these parts.

I do not limit myself to the exact construction of the parts shown, as they may be modified in various ways without departing from my invention.

The collars *B* and ends of cores *E* are provided with rims *b e*, which prevent any escaping oil from spreading upon the axle, collars, hubs, or cores.

If desired, one end of axle *A* may be rigidly attached to one wheel *L*, and have a bearing *i* formed on its end.

Having now described my invention, what I claim as new and desire to secure by letters,—

First—In a car-wheel axle, two car-wheels having bearings upon their outer sides for the axle-boxes of the car, in combination with a centre part or axle made hollow and loosely journaled in each of said car-wheels, said hollow axle being provided with means to admit a lubricant, and holes to allow said lubricant to flow from said axle to its journals in the wheels, substantially as and for the purpose specified.

Second—An axle made of a centre and two end sections, in combination with split cores, arranged to firmly clamp the end sections and form bearings for the centre sections and wheels, the hubs of which clamp the two parts of the cores together, substantially as and for the purpose specified.

Third—The centre part *A* provided with collars *C* upon its ends, in combination with split cores *E* having grooves *GF*, end sections *I* having bearings *i*, and wheels *L* having hubs *K*, substantially as and for the purpose specified.

Fourth—The centre part *A* made hollow and provided on its ends with collars and plugs, split cores *E* having grooves *GF*, end sections *I* having bearings *i*, and wheels *L* having hubs *K*, substantially as and for the purpose specified.

Fifth—The hollow centre part *A* closed on its ends and provided with holes *d*, collars *BC*, and plugs *M*, in combination with cores *E* made in two parts, and having grooves *GF*, end sections *I* having flange *J*, bearings *i*, and channel *I'*, and wheels *L* having hubs *K*, substantially as and for the purpose specified.

Sixth—

Improvements in Wheels and Axles for Railway Vehicles.

Sixth—The combination of hollow axle A, having collars BC, closed end plugs D, and holes *d*, cores E having grooves GF, and made in halves, end sections I, having flanges J, and bearings *i*, discs N, and wheels L having hubs K, substantially as shown.

Seventh—A car-wheel axle made hollow and provided with a series of closed apertures arranged about its circumference to fill it with a lubricant, substantially as and for the purpose specified, in combination with loose wheels upon one or both of its ends.

In witness whereof, I, the said Edward B. Orne, have hereto set my hand and seal, this seventeenth day of November, one thousand eight hundred and eighty-three.

Witness—

W. S. BAYSTON,

Clerk to Edwd. Waters, Patent Agent, Melbourne.

EDWARD B. ORNE,

(By his attorney, J. B. CARTER).

This is the specification referred to in the annexed Letters of Registration granted to Edward B. Orne, this thirteenth day of February, A.D. 1884.

AUGUSTUS LOFTUS.

REPORT.

Sir,

In reply to your B.C. of 10th instant, forwarding a petition from Mr. Edward B. Orne for Letters of Registration for an invention entitled "Improvements in and relating to wheels and axles for railway vehicles," we have the honor to inform you that, having examined the specification and plan accompanying petition, we are of opinion that Letters of Registration may be granted for the invention referred to.

Sydney, 28 December, 1883.

We have, &c.,

JOHN WHITTON.

E. O. MORIARTY.

The Under Secretary of Justice.

[Drawings—one sheet.]

—ORNE'S PATENT—

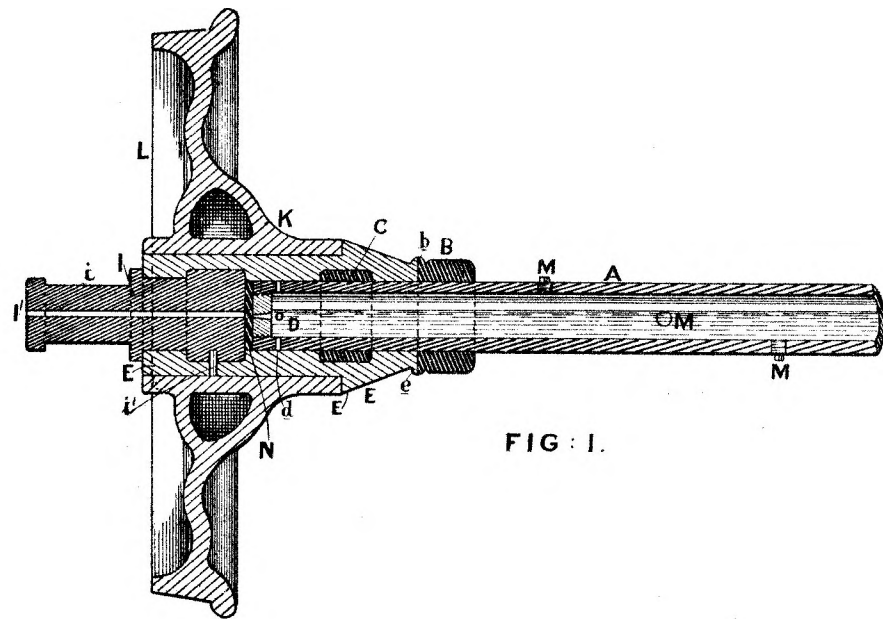


FIG. 1.

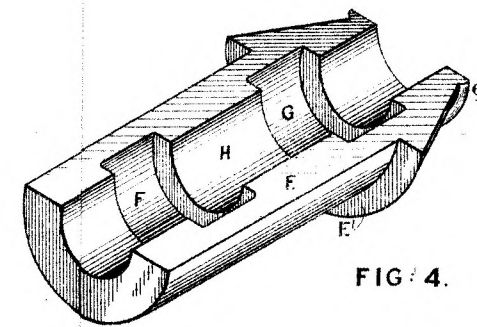


FIG. 4.

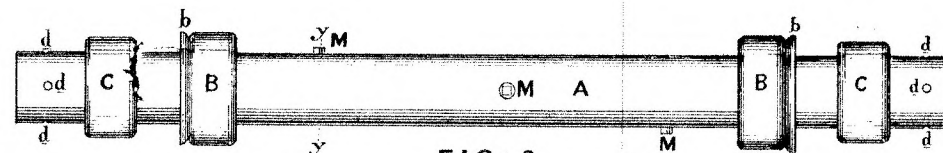


FIG. 3.

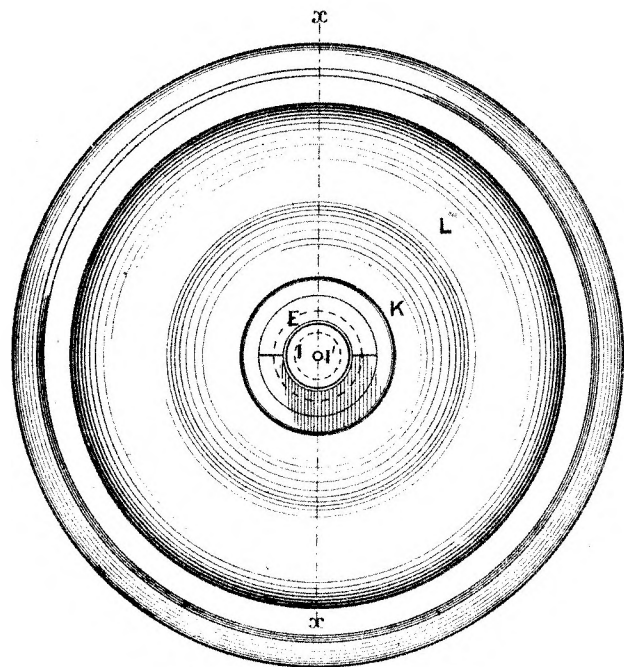


FIG. 2.

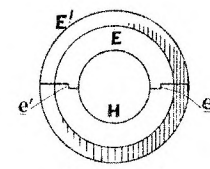


FIG. 6.

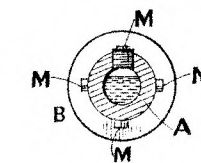


FIG. 5.

*This is the Sheet of Drawings referred to in the annexed
Letters of Registration granted to Edward B. Orne, this
thirteenth day of February, A.D. 1884*

Augustus Loftus



A.D. 1884, 14th February. No. 1390.

IMPROVED STUMP EXTRACTOR.

LETTERS OF REGISTRATION to Wilton Hack, for Improved Stump Extractor.

[Registered on the 16th day of February, 1884, in pursuance of the Act 16 Vic. No. 24.]

BY HIS EXCELLENCY THE RIGHT HONORABLE SIR AUGUSTUS WILLIAM FREDERICK SPENCER LOFTUS (commonly called LORD AUGUSTUS LOFTUS), Knight Grand Cross of the Most Honorable Order of the Bath, a Member of Her Majesty's Most Honorable Privy Council, Governor and Commander-in-Chief of the Colony of New South Wales and its Dependencies.

TO ALL TO WHOM THESE PRESENTS SHALL COME, greeting :

WHEREAS WILTON HACK, of Collingrove, Glen Oak, Williams River, in the Colony of New South Wales, gentleman, hath by his Petition humbly represented to me that he is the author or designer of a certain invention or improvement in manufactures, that is to say, of an invention entitled "Improved Stump Extractor," which is more particularly described in the specification and the sheet of drawings which are hereunto annexed; and that he, the said Petitioner, hath deposited with the Honorable the Treasurer of the said Colony of New South Wales the sum of Twenty Pounds sterling, for defraying the expense of granting these Letters of Registration, as required by the Act of Council, sixteenth Victoria, number twenty-four; and hath humbly prayed that I would be pleased to grant Letters of Registration, whereby the exclusive enjoyment and advantage of the said invention or improvement, might be secured to him for a period of fourteen years. And I, being willing to give encouragement to all inventions and improvements in the arts or manufactures which may be for the public good, and having received a report favourable to the prayer of the said Petition from competent persons appointed by me to examine and consider the matters stated therein and to report thereon for my information, am pleased, with the advice of the Executive Council, and in exercise of the power and authority given to me by the said Act of Council, to grant, and do by these Letters of Registration grant unto the said Wilton Hack, his executors, administrators, and assigns, the exclusive enjoyment and advantage of the said invention or improvement for and during the term of fourteen years from the date hereof; to have, hold, and exercise unto the said Wilton Hack, his executors, administrators, and assigns, the exclusive enjoyment and advantage thereof, for and during and unto the full end and term of fourteen years from the date of these presents next and immediately ensuing, and fully to be complete and ended: Provided always, that if the said Wilton Hack shall not, within three days after the granting of these Letters of Registration, register the same in the proper office in the Supreme Court, at Sydney, in the said Colony of New South Wales, then these Letters of Registration, and all advantages whatsoever hereby granted, shall cease and become void.

In witness whereof, I have hereunto set my sign manual, and have caused the present Letters of Registration to be sealed with the seal of the said Colony of New South Wales, at Government House, Sydney, in New South Wales, this fourteenth day of February, in the year of our Lord one thousand eight hundred and eighty-four.

[L.S.]

AUGUSTUS LOFTUS.

Improved Stump Extractor.

SPECIFICATION of Patent for Stump Extractor.

My invention consists of a screw, worked vertically by means of a capstan outside the framework which supports the machine.

The frame C consists of three supports of hardwood. These are inserted into sockets in iron castings B, and are prevented from spreading by a bar of iron, L. When the ground is of a soft nature stout pieces of flat timber may be placed beneath the ends of these supports to prevent their sinking.

To one of the supports a wheel S is attached, which, by moving the lever T, throws the point of the support from the ground, wheels P being placed under hooks O. The machine is then ready for being shifted from one stump to another.

The framework may also be made with four supports instead of three. In such a case, two of the supports on the one side are secured at the base on a wooden frame, beneath which wheels are placed, the same being done on the opposite side.

The screw D is worked by a capstan A, on the ball and socket principle. At the lower end of the screw a goose-necked shackle E is attached, into which the chain F may be secured or loosened without loss of time.

The capstan rests on a casting B, through which the screw D passes, the passage through this casting being so constructed that the deviation of the screw from a true perpendicular may not be interfered with. The chain F is simply looped round the stump H, and secured by the shackle E.

When the machine is adjusted over the stump the wheels are detached, and the levers K are pushed round by hand or drawn by a horse.

Having thus described my invention, what I claim as new is the vertical action of the screw, worked by a capstan outside of the framework of the machine, thus giving unlimited power as to leverage. And I claim this as my own invention, which has not been hitherto used, to the best of my knowledge and belief.

WILTON HACK.

This is the specification referred to in the annexed Letters of Registration granted to Wilton Hack, this 14th day of February, A.D. 1884.

AUGUSTUS LOFTUS.

REPORT.

Sir,

Sydney, 7 January, 1884.

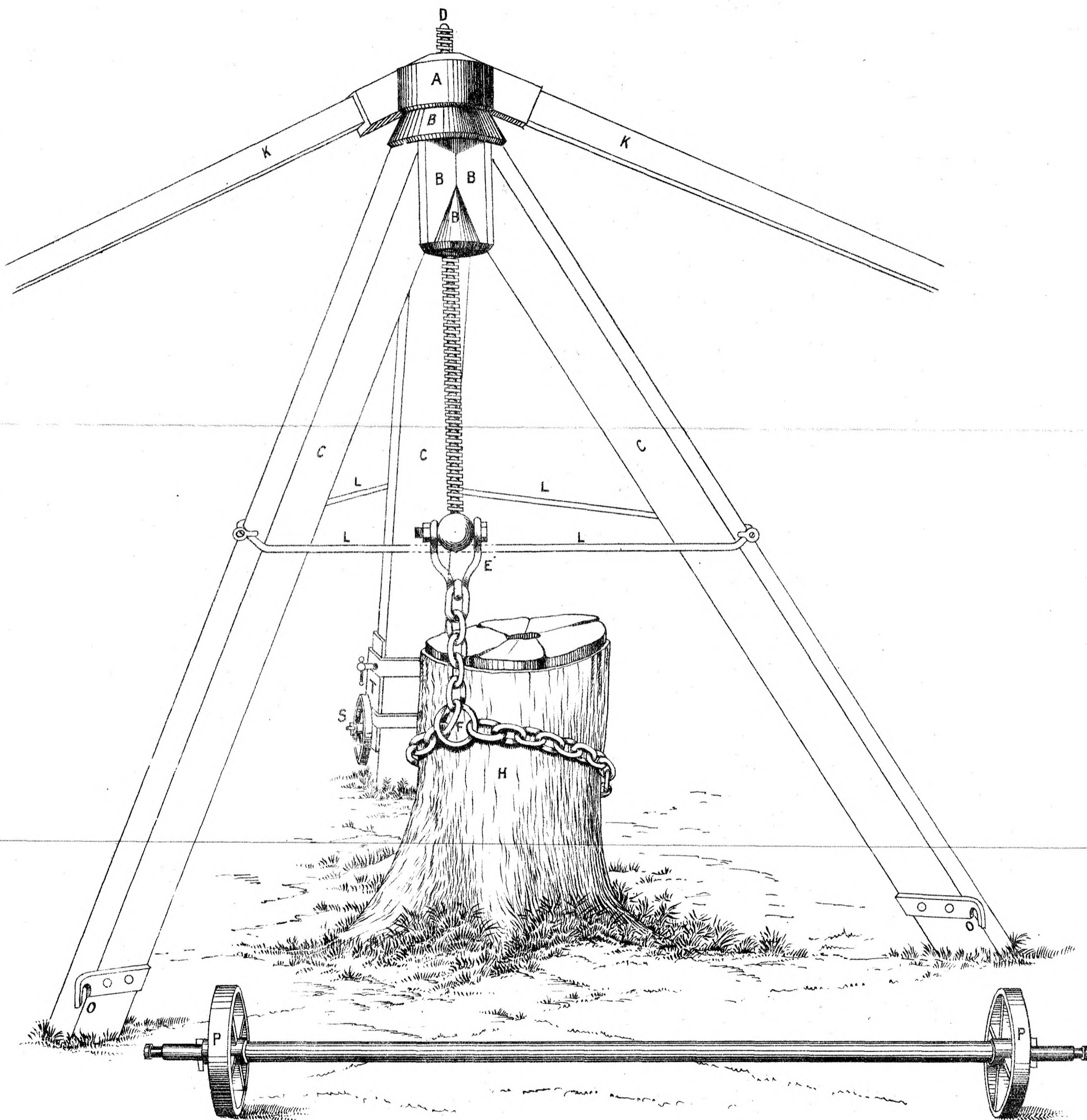
We do ourselves the honor to report, in reply to your blank cover, 22nd December last, No. 14,871, transmitting the petition of Mr. Wilton Hack, for the registration of an invention entitled "An Improved Stump Extractor," that we are of opinion the prayer of the Petitioner may be granted, in terms of his specification, drawings, and claim.

We have, &c.,

GOTHEK K. MANN.
JAMES BARNET.

The Under Secretary of Justice.

[Drawings-- one sheet.]



*This is the Sheet of Drawings referred to in the annexed Letters of Registration,
granted to Wilton Hack, this fourteenth day of February, A. D., 1884.
Augustus Loftus.*



A.D. 1884, 14th February. No. 1391.

IMPROVEMENTS IN MACHINES FOR GRUBBING OR EXTRACTING ROOTS
AND TREES.

LETTERS OF REGISTRATION to Thomas Robert Raney Ashton, for Improve-
ments in Machines for Grubbing or Extracting Roots and Trees.

[Registered on the 16th day of February, 1884, in pursuance of the Act 16 Vic. No. 24.]

BY HIS EXCELLENCY THE RIGHT HONORABLE SIR AUGUSTUS WILLIAM FREDERICK SPENCER LOFTUS
(commonly called LORD AUGUSTUS LOFTUS), Knight Grand Cross of the Most Honorable Order of
the Bath, a Member of Her Majesty's Most Honorable Privy Council, Governor and Commander-in-
Chief of the Colony of New South Wales and its Dependencies.

TO ALL TO WHOM THESE PRESENTS SHALL COME, greeting:

WHEREAS THOMAS ROBERT RANEY ASHTON, of Cowley's Creek, near Port Campbell, in the Colony of Victoria, blacksmith, hath by his Petition humbly represented to me that he is the author or designer of a certain invention or improvement in manufactures, that is to say, of an invention entitled "Improvements in Machines for Grubbing or Extracting Roots and Trees," which is more particularly described in the specification marked A, and the two sheets of drawings marked B and C respectively, which are hereunto annexed; and that he, the said Petitioner, hath deposited with the Honorable the Treasurer of the said Colony of New South Wales the sum of Twenty Pounds sterling, for defraying the expense of granting these Letters of Registration, as required by the Act of Council, sixteenth Victoria, number twenty-four; and hath humbly prayed that I would be pleased to grant Letters of Registration, whereby the exclusive enjoyment and advantage of the said invention or improvement might be secured to him for a period of fourteen years. And I, being willing to give encouragement to all inventions and improvements in the arts or manufactures which may be for the public good, and having received a report favourable to the prayer of the said Petition, from competent persons appointed by me to examine and consider the matters stated therein and to report thereon for my information, am pleased, with the advice of the Executive Council, and in exercise of the power and authority given to me by the said Act of Council, to grant, and do by these Letters of Registration grant unto the said Thomas Robert Raney Ashton, his executors, administrators, and assigns, the exclusive enjoyment and advantage of the said invention or improvement, for and during the term of fourteen years from the date hereof; to have, hold, and exercise unto the said Thomas Robert Raney Ashton, his executors, administrators, and assigns, the exclusive enjoyment and advantage thereof, for and during and unto the full end and term of fourteen years from the date of these presents next and immediately ensuing, and fully to be complete and ended: Provided always, that if the said Thomas Robert Raney Ashton shall not, within three days after the granting of these Letters of Registration, register the same in the proper office in the Supreme Court, at Sydney, in the said Colony of New South Wales, then these Letters of Registration, and all advantages whatsoever hereby granted, shall cease and become void.

In witness whereof, I have hereunto set my sign manual, and have caused the present Letters of Registration to be sealed with the seal of the said Colony of New South Wales, at Government House, Sydney, in New South Wales, this fourteenth day of February, in the year of our Lord one thousand eight hundred and eighty-four.

[L.S.]

AUGUSTUS LOFTUS.

Improvements in Machines for Grubbing or Extracting Roots and Trees.

A.

SPECIFICATION of THOMAS ROBERT RANEY ASHTON, of Cowley's Creek, near Port Campbell, in the Colony of Victoria, blacksmith, for an invention entitled "Improvements in Machines for Grubbing or Extracting Roots and Trees."

MACHINES for extracting or grubbing stumps and trees by pulling them down or out of the earth are now commonly made with a perforated or notched anchor-plate, the perforations or notches in which form fulcra for the pins of levers by which the strain is put upon the tree or stump. Now, I use a perforated or rather a slotted anchor-plate, the holes or slots in which I also use as the fulcra of a lever by which I put the strain upon the tree or stump; but instead of using pins to work in said slots I use dogs or pawls, and instead of such pins having to be placed in the holes by a person specially provided for the purpose, I make my dogs or pawls fall into their proper holes or slots automatically. I am aware that spring pawls, which work automatically, have been used with an anchor-plate having notches or teeth on either side, but I require no springs, and my anchor-plate is not notched, but slotted. In all other machines also this anchor-plate is made flat and straight, and I can make mine flat and straight also, but all such machines can only give a strain from one end of the anchor-plate to the other without relaxing the grip and taking a fresh strain. Now, by making my anchor-plate circular, and providing it with a chain-sheave or pulley on either side, the strain can be continued until the whole of the chain is wound on, and as this in practice will always be long enough for the maximum strain ever needed, it follows that there will be one continuous pull until the tree or stump is extracted.

On sheet 1 of my drawings I have shown the first form of my invention; figure 1 being top view, figure 2 side view, figures 3, 4, and 5, sections on the lines *a a*, *b b*, and *c c* respectively, while figure 6 shows the temporary connecting rod for attaching the anchor-plate to the chain, while the lever is being slid up to take a fresh strain, as will be hereinafter explained. It will at once be seen that A is the slotted anchor-plate and A¹ the slots therein, B the chain around the anchorage, and C the chain leading to the tree or stump to be extracted; D is the lever, and D¹ D² are the dogs or pawls, which pivot on pins at D². This lever terminates in an iron piece, D³, to which is bolted a back piece, D⁴ (see figure 4), so as to form a slot for keeping it to the anchor-plate.

In operation this machine works as follow:—The anchor chain B is passed around the anchorage and fastened as shown, the lever is slid along the anchor-plate until it is in the position shown in dotted lines in figure 1, and the hauling chain then tightened on the tree or stump to be extracted; the lever is then worked to and fro sufficiently far to allow of the dogs or pawls D¹ alternately falling into the slots, and then rising out of them and travelling to the next, thereby drawing the hauling chain with them, until the dogs or pawls reach those slots which are nearest the anchorage, when the temporary rod E (figure 6) is hooked on to one or other of the slots A², and its other end connected by pin E¹ to the triangular piece C¹ on the hauling chain. The dogs or pawls are then released from the slots, and they and the lever slid back to their original position, as indicated in dotted lines in figure 1; the superfluous length of chain is then dropped down or disconnected, and the end of the straining rod D³ connected to that link or part of the chain which it will reach, and the temporary connecting rod E disconnected and removed. The chain can then be renewed as at the first.

On sheet 2 of my drawings I have illustrated the circular form of my machine, which I think by far the best. In it the mechanical principle by which I obtain the leverage is the same as in the form already described; but, instead of making the anchor-plate straight, I make it circular. Figure 1 shows top view of such a machine; figure 2, side view; figure 3, end view; figure 4, vertical section through one of the chain sheaves or pulleys showing the teeth which grip the haulage chains; figure 5, method of lengthening the lever. In these drawings, A is the slotted anchor-plate made in this case circular or wheel-shaped; B, the link attaching the end framing B¹ of the machine to the chain around the anchorage. In this case the lever is not slotted at the end as in the former case, but is attached by connecting rod E, having pins or studs therein to the lug B² provided on the triangular plate B¹, which forms the end of the frame. This triangular plate is connected by rods F to the side-framing G, in the upper part of which is the bearing for the axle G¹, upon which the circular or wheel-shaped anchor-plate A and the chain sheaves or pulleys H H are fixed. The slotted wheel-shaped anchor-plate A and chain sheaves H H are firmly bolted together by the bolts H² passing through them. G² are stays. J J are travelling wheels for conveniently moving the machine from place to place. C C are the haulage chains having the swivel links C¹ at their ends, and which are connected to triangular piece C², to which is attached the other part of the haulage chain leading to the tree or stump to be extracted. H¹ is a guard or finger to push the links off the chain sheave or pulley, thereby preventing the chain from being wound on it as in figure 4. D is the lever, and D¹ the dogs or pawls attached to and worked thereby through the medium of connecting rods D².

The operation of this machine is as follows:—The anchor chain is passed around the anchorage as before, the haulage chain tightened, and the lever worked to and fro, as before, with this result, that the slotted or wheel-shaped anchor-plate is revolved forward, taking with it the chain sheaves or pulleys on either side and the teeth in same gripping, the haulage chain draws it forward, but does not wind it up as it falls down, as shown in figure 4. This can proceed until the whole of the double part of the haulage chain is wound up, and this will of course be made sufficiently long to give more than the maximum degree of strain ever required of the machine.

Having thus described the nature of my invention and the manner of performing same, I would have it understood that what I believe to be new, and therefore claim as my improvements in machines for grubbing or extracting roots and trees, is—

First—The combination of the slotted anchor-plate A with the lever D and its dogs or pawls D¹, substantially as herein described and explained, and as illustrated on sheet 1 of my drawings.

Second—The combination of the circular or wheel-shaped anchor-plate A with the lever D and its dogs D¹, substantially as herein described and explained, and as illustrated on sheet 2 of my drawings.

Third

Improvements in Machines for Grubbing or Extracting Roots and Trees.

Third—The combination of chain sheaves or pulleys H with the circular or wheel-shaped anchor-plate A, substantially as herein described and explained, and as also illustrated on sheet 2 of my drawings.

In witness whereof, I, the said Thomas Robert Raney Ashton, have hereto set my hand and seal, this seventeenth day of December, 1883.

Witness—

JOHN COUSINS,

Engine-driver, Cowley's Creek.

THOMAS ROBERT RANEY ASHTON.

This is the specification marked A referred to in the annexed Letters of Registration granted to Thomas Robert Raney Ashton, this fourteenth day of February, A.D. 1884.

AUGUSTUS LOFTUS.

REPORT.

Sir,

We do ourselves the honor to report, in reply to your blank cover of the 22nd December last, No. 14,959, transmitting the Petition of Thomas Robert Raney Ashton for the registration of an invention entitled "Improvements in Machines for Grubbing or Extracting Trees," that we are of opinion the prayer of the Petitioner may be granted, in terms of his specification, drawings, and claim.

We have, &c.,

GOTHEK K. MANN.
JAMES BARNET.

The Under Secretary of Justice.

[Drawings—two sheets.]

T.R.R. ASHTON'S PATENT.

Sheet 1.

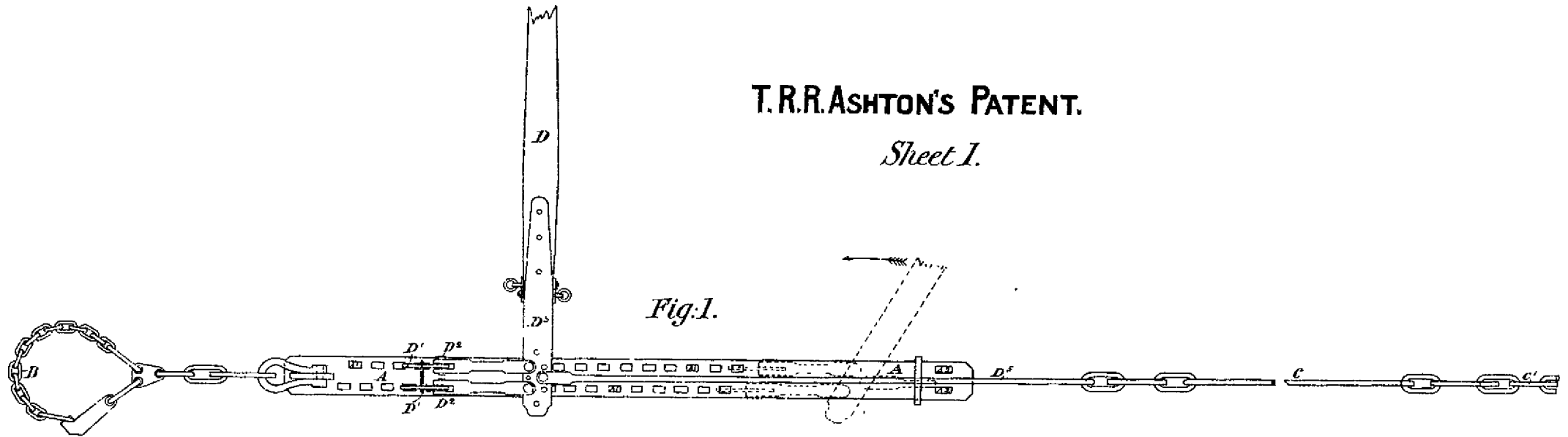


Fig. 1.



Fig. 2.

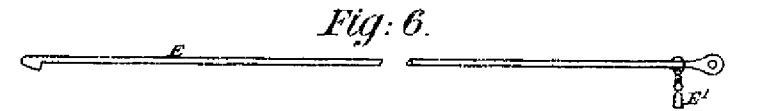


Fig. 6.



Fig. 3.

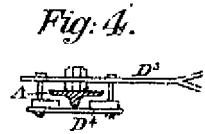


Fig. 4.



Fig. 5.

This is the Sheet of Drawings marked B, referred to in the annexed Letters of Registration, granted to Thomas Robert Raney Ashton, this fourteenth day of February, A.D. 1884.

Augustus Loftus.

(Sig: 245~)

T.R.RASHTON'S PATENT.

Sheet 2.

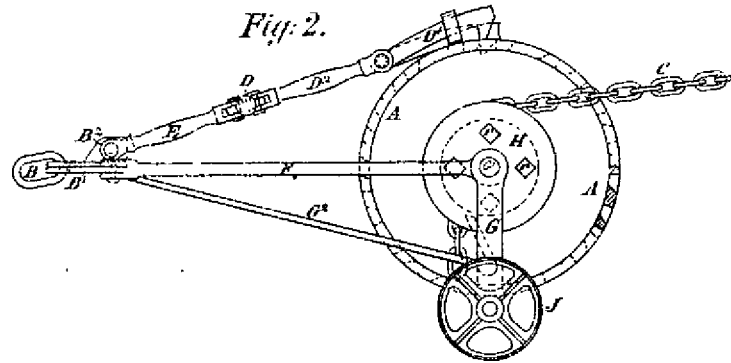


Fig. 2.

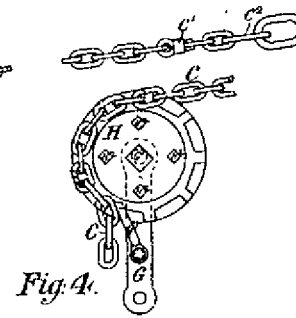


Fig. 4.

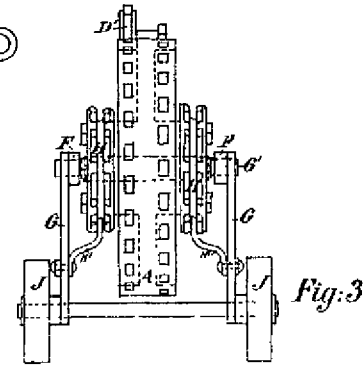


Fig. 3.

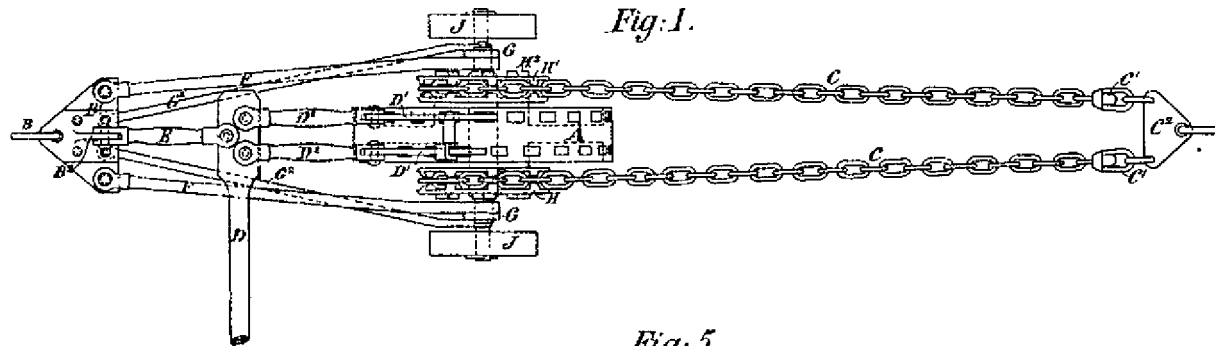


Fig. 1.

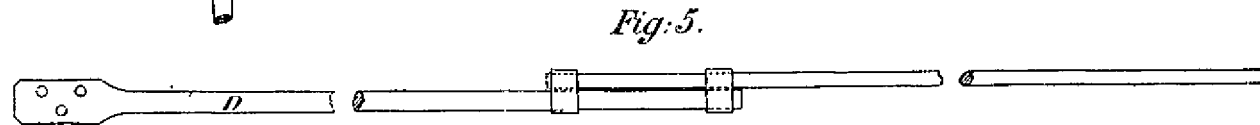


Fig. 5.

This is the Sheet of Drawings marked C, referred to in the annexed Letters of Registration, granted to Thomas Robert Raney Ashton, this fourteenth day of February, A.D., 1884.

Augustus Loftus.



A.D. 1884, 14th February. No. 1392.

IMPROVED APPLIANCES FOR VENTILATING CHURCHES, SCHOOLS, &c.

LETTERS OF REGISTRATION to Richard Oakley, for Improved Appliances for Ventilating Churches, Schools, and other Buildings.

[Registered on the 16th day of February, 1884, in pursuance of the Act 16 Vic. No. 24.]

BY HIS EXCELLENCY THE RIGHT HONORABLE SIR AUGUSTUS WILLIAM FREDERICK SPENCER LOFTUS (commonly called LORD AUGUSTUS LOFTUS), Knight Grand Cross of the Most Honorable Order of the Bath, a Member of Her Majesty's Most Honorable Privy Council, Governor and Commander-in-Chief of the Colony of New South Wales and its Dependencies.

TO ALL TO WHOM THESE PRESENTS SHALL COME, greeting :

WHEREAS RICHARD OAKLEY, of No. 235, High Holborn, in the County of Middlesex, England, ventilating engineer, hath by his Petition humbly represented to me that he is the author or designer of a certain invention or improvement in manufactures, that is to say, of an invention entitled "Improved appliances for Ventilating Churches, Schools, and other Buildings," which is more particularly described in the specification and the sheet of drawings which are hereunto annexed; and that he, the said Petitioner, hath deposited with the Honorable the Treasurer of the said Colony of New South Wales the sum of Twenty Pounds sterling, for defraying the expense of granting these Letters of Registration, as required by the Act of Council, sixteenth Victoria, number twenty-four; and hath humbly prayed that I would be pleased to grant Letters of Registration, whereby the exclusive enjoyment and advantage of the said invention or improvement might be secured to him for a period of fourteen years: And I, being willing to give encouragement to all inventions and improvements in the arts or manufactures which may be for the public good, and having received a report favourable to the prayer of the said Petition, from competent persons appointed by me to examine and consider the matters stated therein and to report thereon for my information, am pleased, with the advice of the Executive Council, and in exercise of the power and authority given to me by the said Act of Council, to grant, and do by these Letters of Registration grant unto the said Richard Oakley, his executors, administrators, and assigns, the exclusive enjoyment and advantage of the said invention or improvement, for and during the term of fourteen years from the date hereof; to have, hold, and exercise unto the said Richard Oakley, his executors, administrators, and assigns, the exclusive enjoyment and advantage thereof, for and during and unto the full end and term of fourteen years from the date of these presents next and immediately ensuing, and fully to be complete and ended: Provided always, that if the said Richard Oakley shall not, within three days after the granting of these Letters of Registration, register the same in the proper office in the Supreme Court, at Sydney, in the said Colony of New South Wales, then these Letters of Registration, and all advantages whatsoever hereby granted, shall cease and become void.

In witness whereof, I have hereunto set my sign manual, and have caused the present Letters of Registration to be sealed with the seal of the said Colony of New South Wales, at Government House, Sydney, in New South Wales, this fourteenth day of February, in the year of our Lord one thousand eight hundred and eighty-four.

[L.S.]

AUGUSTUS LOFTUS.

Improved appliances for Ventilating Churches, Schools, and other Buildings.

SPECIFICATION of RICHARD OAKLEY, of No. 235, High Holborn, in the County of Middlesex, England, ventilating engineer, for an invention entitled "Improved appliances for Ventilating Churches, Schools, and other Buildings."

THIS invention has for its object improved appliances for ventilating churches, schools, and other buildings.

The improved ventilating appliances constituting my invention are represented by the drawings annexed. I call the apparatus "The Æolus Invisible Exhaust Roof Ventilator."

It consists of four or more horizontal triangular plates of any material fixed to a frame of any material sloping inwards and downwards and converging to a centre at any angle up to 90° , and of four or more other horizontal triangular plates of any material sloping inwards and upwards to the same centre at any angle up to 90° , and of four or more other triangular vertical plates set at right angles to the eight or more horizontal plates previously described, the said vertical plates dividing the head into four or more compartments, all converging to one centre, as shown in the diagram marked No. 1, and of a tube, either round or square, divided into two or more compartments descending vertically from the said centre, each compartment communicating with one or other of the pairs of sloping plates to which they are fixed.

Figure 1a is a horizontal section taken on the line 1 1 in figure 1. Figure 1b is a vertical section.

In these figures the triangular plates referred to above, and sloping inwards and upwards, are marked *a a a a*, and *b b b b* are the vertical plates; *c'* and *c* are the two compartments of the central tube or tubes.

These vertical tubes may be continued as such to any convenient distance and then turn horizontally right and left into a horizontal tube, which may be made of any material and of any diameter. The relative positions of the vertical tube descending from the sloping plates and of the horizontal tubes in which they extend is shown in figure 2. The last-named horizontal tube runs into at each of its ends another tube set at right angles to itself. These last tubes are open at each end, and are intended to run athwart the roof and open out through each side of it. A plan of these three horizontal tubes, with the vertical tube descending into it and branching right and left in the middle one of the three, is shown in figure 3.

In figure 3 the two compartments of the descending vertical tube are again marked *c' c'*; they branch horizontally into the horizontal tube *d*, and this communicates with the two tubes *e e*, which pass through the upper part of the roof from side to side. In figure 2 the arrangement of the parts in relation to the roof is seen at the upper part; immediately beneath the ridge is the apparatus consisting of the plates *a a*, with corresponding upper plates, and the vertical plates *b*, together forming funnel-like entrances to the divided pipe *c' c'*. The larger pipe *d*, into which *c' c'* open, is seen below, as are also portions of the pipes *e e*.

From the centre of the middle tube descends another vertical shaft of larger or less diameter, as required, and is divided by a plate running down its centre, falling in the same plane as the two side shafts, and terminating in an expanded cone having its mouth open. This cone may be of any size required. The position of the cone is shown by figure 2. It is immaterial whether more than one cone be fixed on to the apparatus. Sometimes I divide the head, shown by figure 1, into two parts, and separate the parts by an interval in order to obtain better exposure on the two sides of the roof. The principle on which this ventilator acts is partly by injection from above, and partly by suction from the transverse tubes.

What I claim is, the improved ventilating appliance herein described, which I call the Æolus Invisible Exhaust Roof Ventilator.

In witness whereof, I, the said Richard Oakley, have hereunto set my hand and seal, this twenty-third day of October, 1883.

RICHARD OAKLEY.

This is the specification referred to in the annexed Letters of Registration granted to Richard Oakley, this fourteenth day of February, A.D. 1884.

AUGUSTUS LOFTUS.

REPORT.

Sir,

Sydney, 24 December, 1883.

The application of Mr. R. Oakley for Letters of Registration for "Improved appliances for Ventilating Churches, Schools, and other Buildings" having been referred to us, we have examined the plans and specification accompanying the same, and have now the honor to report that we see no objection to the issue of Letters of Registration, as prayed for.

We have, &c.,

JAMES BARNET.
EDMUND FOSBERY.

The Under Secretary of Justice.

Fig. 1.



Fig. 1^b.

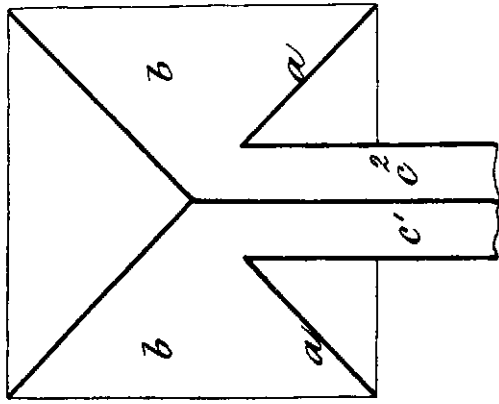


Fig. 2.

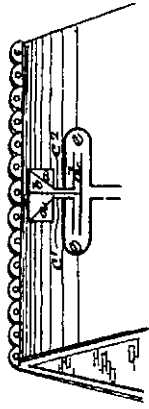


Fig. 3.

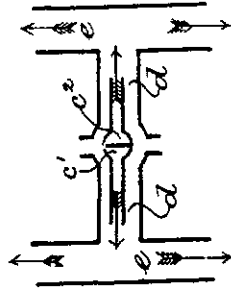
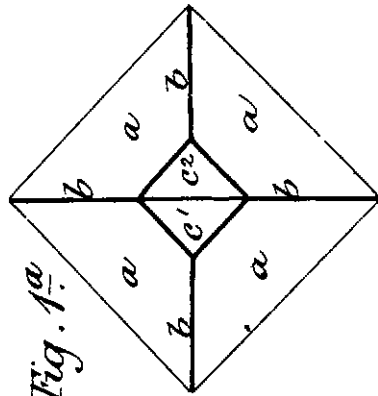
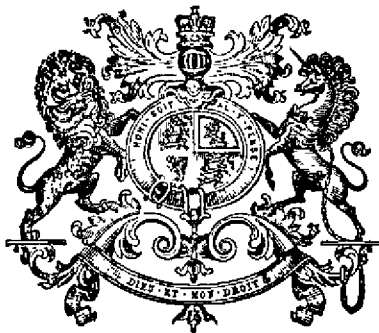


Fig. 1^a.



This is the Sheet of Drawings referred to in the annexed Letters of Registration, granted to Richard Oahley, this fourteenth day of February, A.D., 1884. Augustus Loftus.



A.D. 1884, 18th *February*. No. 1393.

A PRESSURE REGULATOR.

LETTERS OF REGISTRATION to Isaac Roff, Robert Spencer Eastham, and Joshua Alexander Kay, for a Pressure Regulator.

[Registered on the 18th day of February, 1884, in pursuance of the Act 16 Vic. No. 24.]

BY HIS EXCELLENCY THE RIGHT HONORABLE SIR AUGUSTUS WILLIAM FREDERICK SPENCER LOFTUS (commonly called LORD AUGUSTUS LOFTUS), Knight Grand Cross of the Most Honorable Order of the Bath, a Member of Her Majesty's Most Honorable Privy Council, Governor and Commander-in-Chief of the Colony of New South Wales and its Dependencies.

TO ALL TO WHOM THESE PRESENTS SHALL COME, greeting :

WHEREAS ISAAC ROFF, ROBERT SPENCER EASTHAM, and JOSHUA ALEXANDER KAY, all of Melbourne, Victoria, have by their Petition humbly represented to me that they are the authors or designers of a certain invention or improvement in manufactures, that is to say, of an invention entitled "A Pressure Regulator," which is more particularly described in the specification and the sheet of drawings which are hereunto annexed; and that they, the said Petitioners, have deposited with the Honorable the Treasurer of the said Colony of New South Wales the sum of Twenty Pounds sterling, for defraying the expense of granting these Letters of Registration, as required by the Act of Council, sixteenth Victoria, number twenty-four; and have humbly prayed that I would be pleased to grant Letters of Registration, whereby the exclusive enjoyment and advantage of the said invention or improvement might be secured to them for a period of fourteen years: And I, being willing to give encouragement to all inventions and improvements in the arts or manufactures which may be for the public good, and having received a report favourable to the prayer of the said Petition, from competent persons appointed by me to examine and consider the matters stated therein and to report thereon for my information, am pleased, with the advice of the Executive Council, and in exercise of the power and authority given to me by the said Act of Council, to grant, and do by these Letters of Registration grant unto the said Isaac Roff, Robert Spencer Eastham, and Joshua Alexander Kay, their executors, administrators, and assigns, the exclusive enjoyment and advantage of the said invention or improvement, for and during the term of fourteen years from the date hereof; to have, hold, and exercise unto the said Isaac Roff, Robert Spencer Eastham, and Joshua Alexander Kay, their executors, administrators, and assigns, the exclusive enjoyment and advantage thereof, for and during and unto the full end and term of fourteen years from the date of these presents next and immediately ensuing, and fully to be complete and ended: Provided always, that if the said Isaac Roff, Robert Spencer Eastham, and Joshua Alexander Kay, shall not, within three days after the granting of these Letters of Registration, register the same in the proper office in the Supreme Court, at Sydney, in the said Colony of New South Wales, then these Letters of Registration, and all advantages whatsoever hereby granted, shall cease and become void.

In witness whereof, I have hereunto set my sign manual, and have caused the present Letters of Registration to be sealed with the seal of the said Colony of New South Wales, at Government House, Sydney, in New South Wales, this eighteenth day of February, in the year of our Lord one thousand eight hundred and eighty-four.

[L.S.]

AUGUSTUS LOFTUS.

A Pressure Regulator.

SPECIFICATION of an Invention intituled "Pressure Regulator," for gas, water, steam, liquors, and other vapours.

TO ALL TO WHOM THESE PRESENTS SHALL COME: We, ISAAC ROFF, merchant, ROBERT SPENCER EASTHAM, engineer, and JOSHUA ALEXANDER KAY, mechanical engineer, all of Melbourne, in the Colony of Victoria, send greeting:

WHEREAS we are desirous of obtaining Royal Letters Patent for securing unto us, our executors, administrators, and assigns, Her Majesty's special license for an invention intituled "A Pressure Regulator." We do hereby declare the nature of our said invention and the manner in which the same is to be performed, to be particularly described and ascertained in and by the following statement, that is to say, this invention relates to regulators for checking the uneven flow or pressure of gas, water, steam, and other liquids or vapours, and consists of an external and internal cone-tube or cone-tubes, combined or separate, inserted or fixed in the delivery pipe by calculated diameters and distances from point of discharge; such pressures are brought to uniformity by the check on the external part of the cone-tube or tubes, causing a recoil pressure through the internal cone-tube or tubes, thus forming a steady delivery, and thereby in gas effecting a saving of from 20 to 25 per cent.

The accompanying drawings will illustrate what we mean. Figs. 1 and 2 illustrate our cone-tube in steam-pipe of engine. Fig. 3 shows our cone-tube in a gas-burner. Fig. 4 shows our cone-tube in the gas-pipe. Figs. 5 and 6 shows longitudinal and end sections of cone-tube. A is the cone-tube. B is the delivery-pipe. C is the gas-burner.

The mode of operation is as follows:—The inside of delivery-pipe having been prepared by a rimer, screw-tap, or otherwise, the cone-tube is inserted with external or small end facing the pressure, the force of gas, water, or other substance, being applied, strikes against the external part of the cone, thereby cushioning and causing a certain recoil pressure to take place against the opposing pressure, and thus producing a concentrated force against the sharp edge of external cone-tube; having entered the orifice it is allowed immediate expansion in the internal portion of cone-tube, the size of orifice, as compared with the delivery-pipe, under these circumstances, causing and effecting a uniformity of discharge.

As the external and internal cone tube or tubes may be cast or otherwise formed in the pipe, no matter how connected, we would consider it an infringement of our invention.

Having thus described the nature of our invention, and the manner of performing the same, we would have it understood that what we claim as new, and therefore desire to secure by Letters Patent, is—

First—The insertion or otherwise in delivery or other pipes of an external and internal cone-tube or cone-tubes with the external portion and small orifice facing the pressure, substantially as shown in figs. 2 and 4.

Second—The combination of external and internal cone-tube or cone-tubes with gas-burner, substantially as shown in fig. 3.

In witness whereof, we, the said Isaac Roff, Robert Spencer Eastham, and Joshua Alexander Kay, herewith set our hand and seal this twentieth day of December, A.D. 1883.

Witness—
WILLIAM KEMP.

ISAAC ROFF.
ROBERT SPENCER EASTHAM.
JOSHUA ALEXANDER KAY.

This is the specification referred to in the annexed Letters or Registration granted to Isaac Roff, Robert Spencer Eastham, and Joshua Alexander Kay, this eighteenth day of February, A.D. 1884.

AUGUSTUS LOFTUS.

REPORT.

Sir,

We do ourselves the honor to report, in reply to your blank cover of the 31st ultimo, No. 15,075, transmitting the Petition of Isaac Roff, Robert Spencer Eastham, and Joshua Alexander Kay, for the registration of an invention or improvement entitled "A Pressure Regulator," that we are of opinion the prayer of the Petitioners may be granted, in terms of their specification, drawings, and claim.

We have, &c.,
GOTHER K. MANN.
JAMES BARNET.

The Under Secretary of Justice.

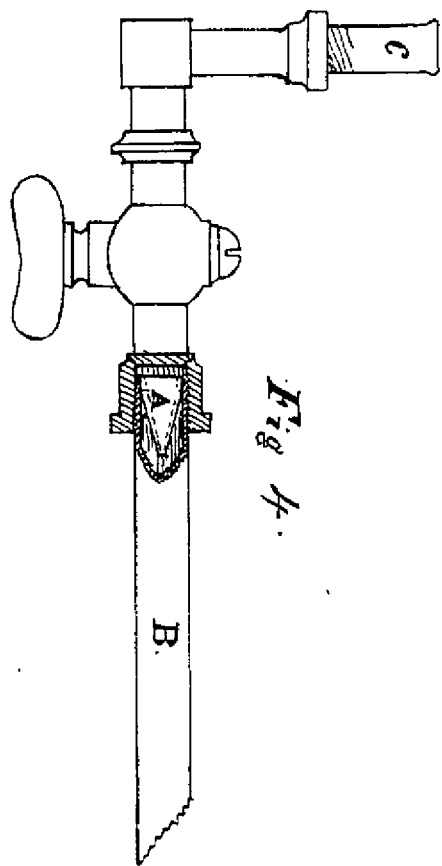
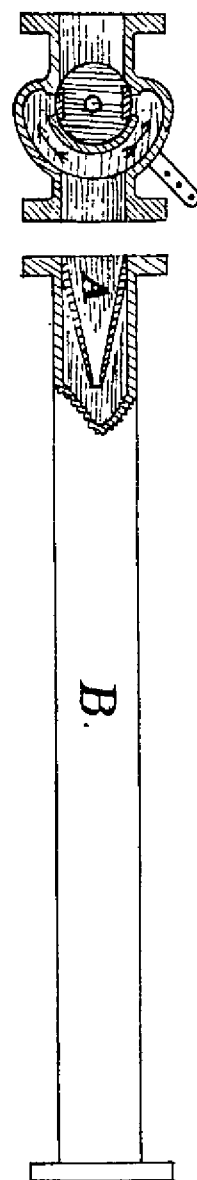
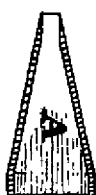


Fig. 4.



Figs. 1 & 2.



Figs. 5 & 6.

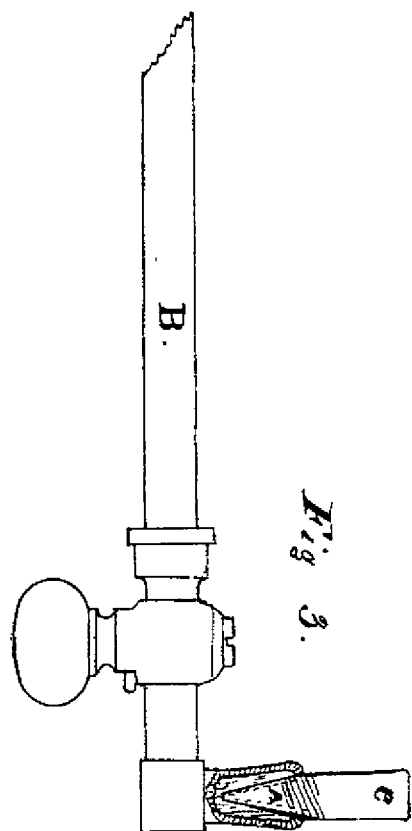


Fig. 3.

(Sig: 245-)

This is the Sheet of Drawings referred to in the annexed Letters of Registration, granted to Isaac Hoff, Robert Spencer Eastham, and Joshua Alexander Kay, the eighteenth day of February, A. D., 1884.

Augustus Loftus.



A.D. 1884, 18th February. No. 1394.

AN IMPROVED APPARATUS FOR BLASTING PURPOSES.

LETTERS OF REGISTRATION to Robert Punshon and Robert Robinson Vizer, for an Improved Method of, and Apparatus for, utilizing an Explosive Compound for Blasting and other purposes.

[Registered on the 19th day of February, 1884, in pursuance of the Act 16 Vic. No. 24.]

BY HIS EXCELLENCY THE RIGHT HONORABLE SIR AUGUSTUS WILLIAM FREDERICK SPENCER LOFTUS (commonly called LORD AUGUSTUS LOFTUS), Knight Grand Cross of the Most Honorable Order of the Bath, a Member of Her Majesty's Most Honorable Privy Council, Governor and Commander-in-Chief of the Colony of New South Wales and its Dependencies.

TO ALL TO WHOM THESE PRESENTS SHALL COME, greeting :

WHEREAS ROBERT PUNSHON and ROBERT ROBINSON VIZER, both of London, England, have by their Petition humbly represented to me that they are the authors or designers of a certain invention or improvement in manufactures, that is to say, of an invention entitled "An Improved Method of, and Apparatus for, utilizing an Explosive Compound for Blasting or other purposes," which is more particularly described in the specification which is hereunto annexed ; and that they, the said Petitioners, have deposited with the Honorable the Treasurer of the said Colony of New South Wales the sum of Twenty Pounds sterling, for defraying the expense of granting these Letters of Registration, as required by the Act of Council, sixteenth Victoria, number twenty-four ; and have humbly prayed that I would be pleased to grant Letters of Registration, whereby the exclusive enjoyment and advantage of the said invention or improvement might be secured to them for a period of fourteen years : And I, being willing to give encouragement to all inventions and improvements in the arts or manufactures which may be for the public good, and having received a report favourable to the prayer of the said Petition from competent persons appointed by me to examine and consider the matters stated therein and to report thereon for my information, am pleased, with the advice of the Executive Council, and in exercise of the power and authority given to me by the said Act of Council, to grant, and do by these Letters of Registration grant unto the said Robert Punshon and Robert Robinson Vizer, their executors, administrators, and assigns, the exclusive enjoyment and advantage of the said invention or improvement, for and during the term of fourteen years from the date hereof ; to have, hold, and exercise unto the said Robert Punshon and Robert Robinson Vizer, their executors, administrators, and assigns, the exclusive enjoyment and advantage thereof, for and during and unto the full end and term of fourteen years from the date of these presents next and immediately ensuing, and fully to be complete and ended : Provided always, that if the said Robert Punshon and Robert Robinson Vizer shall not, within three days after the granting of these Letters of Registration, register the same in the proper office in the Supreme Court, at Sydney, in the said Colony of New South Wales, then these Letters of Registration, and all advantages whatsoever hereby granted, shall cease and become void.

In witness whereof, I have hereunto set my sign manual, and have caused the present Letters of Registration to be sealed with the seal of the said Colony of New South Wales, at Government House, Sydney, in New South Wales, this eighteenth day of February, in the year of our Lord one thousand eight hundred and eighty-four.

[L.s.]

AUGUSTUS LOFTUS.

An Improved Apparatus for Blasting Purposes.

SPECIFICATION of ROBERT PUNSHON and ROBERT ROBINSON VIZER, both of London, England, for an invention entitled "An Improved Method of, and Apparatus for, utilizing an Explosive Compound for Blasting or other purposes."

OUR invention relates to the utilization of a compound of picric acid and nitric acid (the latter of the specific gravity of 1.5) for blasting or similar purposes.

It is known to chemists that nitric acid and picric acid when combined in certain proportions form an explosive compound as powerful as nitro-glycerine, but the use of this compound has not hitherto been found practicable.

The object of our invention is to enable these two acids to be utilized for blasting or similar purposes. This we accomplish by taking a vessel of glass or other acid-proof and friable substance containing nitric acid, and hermetically sealed by means of glass or other acid-proof material, and introducing the said vessel into a case or receptacle in which the said vessel is surrounded or covered with picric acid. We usually make the apparatus in the form of a blasting cartridge. At or in the place where the cartridge is to be exploded, the two acids are caused to combine by breaking the said vessel containing the nitric acid, which may be effected by thrusting a pricker or pointed rod longitudinally, vertically, or otherwise, into the cartridge or by other suitable means, or the vessels and cases containing nitric acid and picric acid respectively, may be put separately and successively into the blasting hole, and be then broken, and the contents thus be caused to combine.

The ingredients should be employed in about the following proportions, viz. :—From one and a half to two parts by weight of picric acid to one part by weight of nitric acid. In some cases we employ in combination with the picric acid, nitrate of potash, nitrate of soda, nitrate of baryta, carbon, or other similar or suitable substance, in order to vary or reduce the explosive power of the above-described compound. It is to be understood that we do not limit ourselves to the form of the cartridges, vessels, or containers, nor to the relative positions which the picric acid and the nitric acid occupy, provided they be in the necessary juxtaposition, or capable of being placed in the necessary juxtaposition, substantially as described.

Having thus fully described our said invention, and the manner of performing the same, we wish it understood that we claim—

- 1st. The utilization of picric acid (pure or combined, as above described) and nitric acid, by enclosing them separately in cartridges, vessels, or containers, in such a manner that the said acids are kept apart for transit or storage, and can be liberated and combined at or in the place where the explosive force of the compound is to be utilized, substantially as hereinbefore described.
- 2nd. An apparatus for blasting or like purposes, consisting of cartridges, vessels, or containers, in which picric acid (pure or combined, as above described) and nitric acid are separately contained, as described.

In witness whereof, we, the said Robert Punshon and Robert Robinson Vizer, have hereunto set our hands and seals, this sixteenth day of November, 1883.

ROBERT PUNSHON.
R. R. VIZER.

Witness—

JOHN J. KNOWLES.

This is the specification referred to in the annexed Letters of Registration granted to Robert Punshon and Robert Robinson Vizer, this eighteenth day of February, A.D. 1884.

AUGUSTUS LOFTUS.

REPORT.

Sir,

Sydney, 10 January, 1884.

In accordance with your B.C. minute of the 3rd instant, forwarding Petition for Letters of Registration for an invention entitled "An Improved Method of, and Apparatus for, utilizing an Explosive Compound for Blasting and other purposes," the Petitioners being Messrs. R. Punshon and R. R. Vizer, we have the honor to report that we are of opinion such Letters should be issued, as prayed for.

We have, &c.,

JAMES BARNET.
WILLIAM C. BENNETT.

The Under Secretary of Justice.



A.D. 1884, 18th February. No. 1395.

IMPROVEMENTS IN ELECTRICAL APPARATUS FOR REGISTERING NUMBERS.

LETTERS OF REGISTRATION to Alfred Upton Alcock, for Improvements in Electrical Apparatus for Registering Numbers, such as for Billiard-marking.

[Registered on the 19th day of February, 1884, in pursuance of the Act 16 Vic. No. 24.]

BY HIS EXCELLENCY THE RIGHT HONORABLE SIR AUGUSTUS WILLIAM FREDERICK SPENCER LOFTUS (commonly called LORD AUGUSTUS LOFTUS), Knight Grand Cross of the Most Honorable Order of the Bath, a Member of Her Majesty's Most Honorable Privy Council, Governor and Commander-in-Chief of the Colony of New South Wales and its Dependencies.

TO ALL TO WHOM THESE PRESENTS SHALL COME, greeting :

WHEREAS ALFRED UPTON ALCOCK, of Russell-street, Melbourne, in the Colony of Victoria, hath by his Petition humbly represented to me that he is the author or designer of a certain invention or improvement in manufactures, that is to say, of an invention entitled "Improvements in Electrical Apparatus for Registering Numbers, such as for Billiard-marking," which is more particularly described in the specification and the sheet of drawings which are hereunto annexed ; and that he, the said Petitioner, hath deposited with the Honorable the Treasurer of the said Colony of New South Wales the sum of Twenty Pounds sterling, for defraying the expense of granting these Letters of Registration, as required by the Act of Council, sixteenth Victoria, number twenty-four ; and hath humbly prayed that I would be pleased to grant Letters of Registration, whereby the exclusive enjoyment and advantage of the said invention or improvement might be secured to him for a period of fourteen years : And I, being willing to give encouragement to all inventions and improvements in the arts or manufactures which may be for the public good, and having received a report favourable to the prayer of the said Petition, from competent persons appointed by me to examine and consider the matters stated therein and to report thereon for my information, am pleased, with the advice of the Executive Council, and in exercise of the power and authority given to me by the said Act of Council, to grant, and do by these Letters of Registration grant to the said Alfred Upton Alcock, his executors, administrators, and assigns, the exclusive enjoyment and advantage of the said invention or improvement for and during the term of fourteen years from the date hereof ; to have, hold, and exercise unto the said Alfred Upton Alcock, his executors, administrators, and assigns, the exclusive enjoyment and advantage thereof, for and during and unto the full end and term of fourteen years from the date of these presents next and immediately ensuing, and fully to be complete and ended : Provided always, that if the said Alfred Upton Alcock shall not, within three days after the granting of these Letters of Registration, register the same in the proper office in the Supreme Court, at Sydney, in the said Colony of New South Wales, then these Letters of Registration, and all advantages whatsoever hereby granted, shall cease and become void.

In witness whereof, I have hereunto set my sign manual, and have caused the present Letters of Registration to be sealed with the seal of the said Colony of New South Wales, at Government House, Sydney, in New South Wales, this eighteenth day of February, in the year of our Lord one thousand eight hundred and eighty-four.

[L.S.]

AUGUSTUS LOFTUS

Improvements in Electrical Apparatus for Registering Numbers.

SPECIFICATION of ALFRED UPTON ALCOCK, of Russell-street, Melbourne, in the Colony of Victoria, for an invention entitled "Improvements in Electrical Apparatus for Registering Numbers, such as for Billiard-marking."

THIS invention consists of certain improvements in electrical apparatus for registering numbers, and is intended mainly as a billiard-marker, although, of course, it can be used for other purposes equally well.

Electrical apparatus for a similar purpose have already been invented, but they have had a fixed dial, and a movable index finger, and the dial necessarily had to be so large in order to be seen at a distance as to make the contrivance cumbersome and unwieldy, and almost precluded their being made to count more than fifty without making them an unpracticable size. Now, in the one form of my apparatus, in which I use a dial, I dispense with the index finger altogether, and make the dials, one for units and another for tens, to revolve, and to do so in such a manner as that the number recorded is shown through a window or opening in the casing. In another form of my apparatus I do not use dials at all, and this is the form which I prefer when the counting required amounts to more than two figures. In such a case I prefer to place the figures 0 to 9 on the periphery of each of three wheels—one for units, one for tens, and another for hundreds—although there is no limit to which this same principle of construction might not be applied if so desired.

In constructing my apparatus I have necessarily used some mechanical contrivances and arrangements that are old and well known in addition to those which are of my own invention, and I wish it to be distinctly understood therefore that I do not claim any parts of the apparatus herein described and illustrated in my drawings except those which are hereinafter expressly claimed as mine.

Referring to my drawings, figure 1 shows front view of the first form of my apparatus, in which two revolving dials are used to indicate the number recorded; figure 2 is a face view of the dials removed from the apparatus, and with the face of the unit dial partially broken away so as to show the detent notches formed on its back; figure 3 is side view of the "tens" dial in figure 2; figure 4 shows a face view of the mechanism of my apparatus with the front board G and dials removed; and figure 5 cross-section of my apparatus at the centre of the units wheel. A is the positive wire, and B the negative. A¹ and B¹ are electro magnets. C is a bar which acts as the armature to said magnets; it rests at one end on a pivot C¹, whilst its other extremity passes through a hole provided in the sliding bar D. From this bar depends a pawl D¹ which gears into ratchet E on spindle E¹, carrying units disc E. From said bar projects two pins D² and D³ which act upon detents F² and F³, pivoted at F and F¹ to small brackets F⁴ and F⁵, fastened to the back casing-board H. Said bar D has two slots in it, D⁴ and D⁵, one at the top and the other at the bottom, for the reception of guide-pins D⁶ and D⁷, which are fastened or screwed into the projecting arms J of angle-pieces or brackets J¹, each of which has a slot in it J² for receiving a screw J³ to fasten it into position. K is a spring to bring the bar C back into position after it has been drawn down by the electro magnets A¹ and B¹ and the electric current has been withdrawn. The unit disc E² projects from the face of a larger disc E³, which has a rim E⁴ all round its edge except where the two slots E⁵ and E⁶ are made in its periphery, and a bar E⁷ passing across the space between said rim and the unit disc. At its back are ten detent notches E⁸. L is the tens disc, on the back of which are ten pins or studs L¹; it is supported on spindle L², which rests in bearings L³ and L⁴ in the back casing-board H and the front board or shutter G.

The operation of this apparatus is as follows. Supposing it to have already registered 29, as shown in figure 1, and to be required to register 30,—the electric current must be sent into the electro magnet, as is well understood, by any suitable contrivance, and generally by simply pressing a button (not shown); the electro magnets A¹ B¹ will then draw down its armature C, thereby pulling down the sliding-bar D, with its upper pin D²; this releases the detent F², and so allows the unit disc E² to revolve; this it does immediately through the action of pendant pawl D¹ gearing into ratchet E, and turning it to the extent of one tooth, equivalent to one number on the unit disc. By this time the lower pin D³ has fallen sufficiently far to allow the lower detent F³ to fall into one of the notches E⁸ at the back (see figure 2), and so to prevent the disc from turning any further round than is needed. The withdrawal of the electric current allows the bar C to resume its normal position (as shown in figure 4), partly by the superior weight of the thick end, and partly by the resilient action of the spring K. The resumption of this position lifts the detent F³ out of gear and the detent F² into gear with one of the notches E⁸ at the back of the units wheel, by means of their respective pins D² and D³.

In registering the number 30 it will be seen that the tens dial has to be revolved to the extent of one figure, and this is accomplished from the units dial by means of bar or bridge E⁷ coming into contact with one of the pins in the back of the tens dial, as clearly shown in figure 2. It will be there seen that as the units dial continues to revolve so as to bring its figure 0 in front of the window the bridge E⁷ will press against the pin at present shown immediately underneath it, and forcing it downwards will partly revolve the tens disc so as to bring the figure 3 on it opposite the 0 in the units disc, and so present the number 30. The said pin will then escape out of the lower slot E⁶ in the rim E⁴ of the disc E³, and take up the position at present occupied by the pin of figure 1 on the tens dial; and the pin opposite to number 3 on the tens dial, now shown as in the mouth of slot E⁵, will be drawn into the position shown by the pin of number 2 on the said dial, only it will be behind and not in front of the bridge E⁷, so that the tens dial will be retained in such position by reason of the outer periphery of the rim E⁴ fitting close against the pins on either side of the pin of 3 that has entered into the slot E⁵ in said rim, until the units dial has made a complete revolution, and another decade has to be entered upon, when the same operation will be repeated. It will readily be understood that the mechanism can be duplicated and placed in one box, so as to form, say, a billiard-marker for the "spot" and "plain" balls.

It would be practicable to make my apparatus with a third revolving dial for indicating the hundreds, but it would not be so good an arrangement as I have invented and illustrated in the drawings hereinafter described, that is to say:—Figure 6 shows front view of the modification of my invention with the front cover removed, which I have devised for the purpose of recording numbers beyond 99 and up to 999, although the indicating wheels would only have to be multiplied in order to record and indicate four or five or more figures; figure 7 shows cross-section on the line *aa* in figure 6; and figure 8 cross-section on the line *bb* in the same figure; figure 9 shows side view of the tens wheel and its driving pinion; and figure 10 side view of the hundreds wheel, and its driving wheel. In these figures M is the main spindle, on which is fastened check-ratchet wheel N, driving ratchet wheel P, and units wheel Q. The tens wheel R and the hundreds wheel S, are both loose on spindle M. T is a spindle which works loosely in its bearings. Q¹ is a pegged disc which is moved

Improvements in Electrical Apparatus for Registering Numbers.

moved one tenth of a revolution by the units wheel Q after such wheel has made each complete revolution. R¹ is a ten-toothed pinion which drives the tens wheel R through the medium of pegs or studs R² thereon (see figure 9). S¹ is a flanged disc on which is a catch S² which drives the hundreds wheel through the medium of pegs or studs S³ thereon (see figure 10). Projecting from the side of the units wheel Q is a rim or flange Q³ having a bridge E⁷ and slot holes E⁵ and E⁶ exactly identical in shape and purpose to the bridge and slot holes similarly marked in figure 2 of my drawings. A is the positive wire and B the negative. A¹ and B¹ are electro magnets. C is a bar which acts as an armature to said magnets, and is hinged at C¹. Its extremity passes through and is attached to sliding-bar D, from which depends a pawl D¹ which gears into ratchet P, on spindle M, carrying units wheel Q. K is a spring. D² and D³ are pins projecting from bar D, and each operating a detent F² and F³ for gearing into check ratchet wheel N. Said bar has two slots in it as before D⁴ and D⁵, one at the top and the other at the bottom, for the reception of guide pins D⁶ and D⁷. M¹ is a spring for keeping the Q¹, R¹, and S¹ in gear with the units, tens, and hundreds wheels respectively, and for admitting of their all being pulled out of gear by handle M², so as to readjust the numeral wheels as may be required. In figure 6 the thick dotted lines which enclose the figures 129 indicate the window or opening in the front cover through which the three figures registered are seen.

The mode of working this apparatus is almost identical with that of my apparatus first herein described, that is to say:—The electric current must be sent into the electro magnets as before; these will draw down the armature C, and with it the sliding bar D; this brings the pendant pawl D¹ into play, which presses down the ratchet wheel P one tooth, the lower detent F³ having been previously removed by the descent of said bar D, and the upper detent F² immediately afterwards descending into the check ratchet N, and so preventing (as in my previously described apparatus) the scoring ratchet wheel from moving more than one notch at a time. With this scoring ratchet wheel the spindle M moves one tenth of a revolution, carrying with it the units wheel. At each complete revolution the bridge E⁷ and slots E⁵ and E⁶ come into play, moving the units disc Q¹ one tenth of a revolution, and with it the spindle T, toothed pinion R¹, and flanged disc S¹. Each such motion of the toothed pinion R¹ carries with it the tens wheel R. Ten such motions of the flanged disc S¹ gives one tenth of a revolution to the hundreds wheel S.

Having thus described the nature of my invention, and the manner of performing same, I would have it understood that I do not claim to be the inventor of electrical apparatus for recording numbers in which the motion is conveyed by means of electro magnets, such as A¹ and B¹, acting on an armature, such as C, working a sliding bar such as D, carrying a pendant pawl such as D¹, working a ratchet such as E or P on a spindle, because up to this point there is nothing new, but in all other machines this spindle is made to carry an index finger, whereas I make it to work either registering discs or registering wheels. I also wish it to be understood that I do not claim to be the inventor of registering machines in which the registration is effected by revolving discs or wheels, the units driving the tens and the tens the hundreds, and so on, but such machines have never been driven or worked by electricity before. Besides this main feature of novelty there are others relating to the construction and arrangement of the parts constituting my electrical apparatus which are now to be specially mentioned and claimed. What I believe therefore to be new, and now claim as my improvements in electrical apparatus for registering numbers, is—

First—The construction of such machines with revolving registering discs or wheels, substantially as herein described and explained, and as illustrated in my drawings.

Second—The combination with sliding arm D, carrying pins D² and D³ of detents F² and F³ to fall into the detent notches E⁵ at the back of the units disc E, for the purpose of preventing the disc E from moving except when required to register, and for preventing it registering more than one number at each motion.

Third—The construction of said units disc E with bridge E⁷ and slots E⁵ and E⁶ for the purpose of giving motion to the tens disc L, as most clearly shown in figure 2; and I also claim the same contrivance, as most clearly shown in figures 7 and 10, for giving motion to the tens and to the hundreds wheels in that machine.

Fourth—The combination and arrangement of the units wheel Q, pegged disc Q¹, shaft T, and pinion R¹, for driving the tens wheel R, and the combination and arrangement of the flanged disc S¹, shaft T, and hundreds wheel S, substantially as and for the purpose described.

Fifth—The combination of the spring M¹ with the shaft T for enabling the contrivances it carries to be thrown out of gear with the registering wheel; and the combination and arrangements of the detents F² and F³ with the check ratchet N, for the purpose herein described and explained.

In witness whereof, I, the said Alfred Upton Alcock, have hereunto set my hand and seal, this twenty-seventh day of December, one thousand eight hundred and eighty-three.

Witness—

W. S. BAYSTON,
Clerk to Edward Waters, Patent Agent, Melbourne.

A. U. ALCOCK.

This is the specification referred to in the annexed Letters of Registration granted to Alfred Upton Alcock, this eighteenth day of February, A.D. 1884.

AUGUSTUS LOFTUS.

REPORT.

Sir,

The application of Alfred Upton Alcock for Letters of Registration for an invention entitled "Improvements in Electrical Apparatus for Registering Numbers, such as for Billiard-marking" having been referred to us for report, we have examined the plan and specification accompanying the same, and have now the honor to report that we see no objection to the issue of Letters of Registration as applied for.

We have, &c.,

ARCH. FRASER.
THOS. RICHARDS.

The Under Secretary of Justice.

[Drawings—one sheet.]

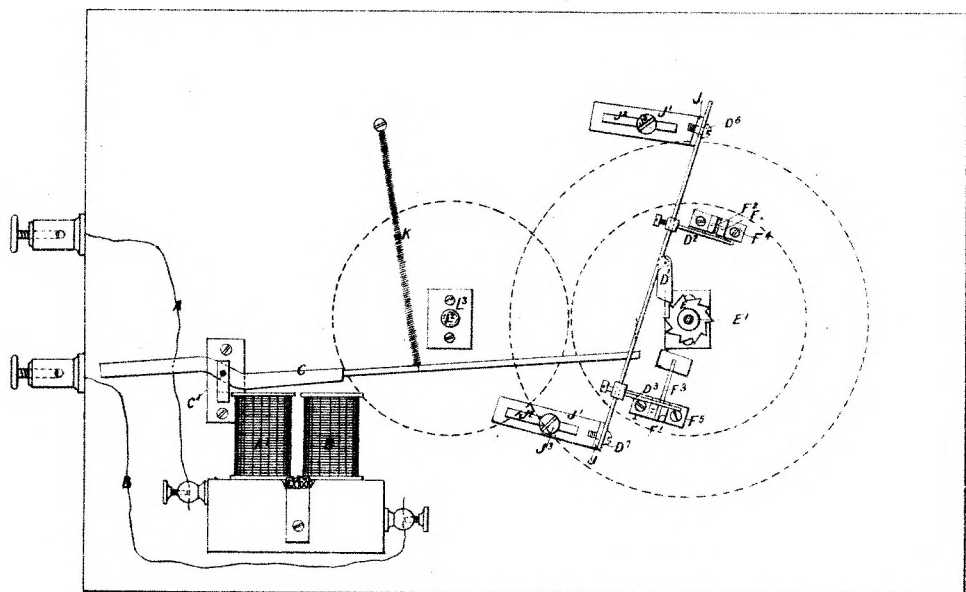


FIG. 4.

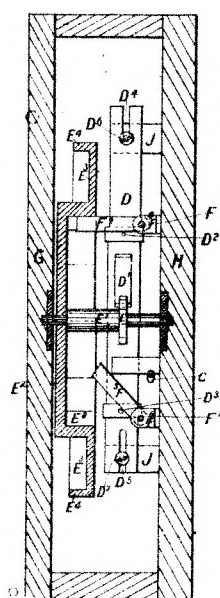


FIG. 5.

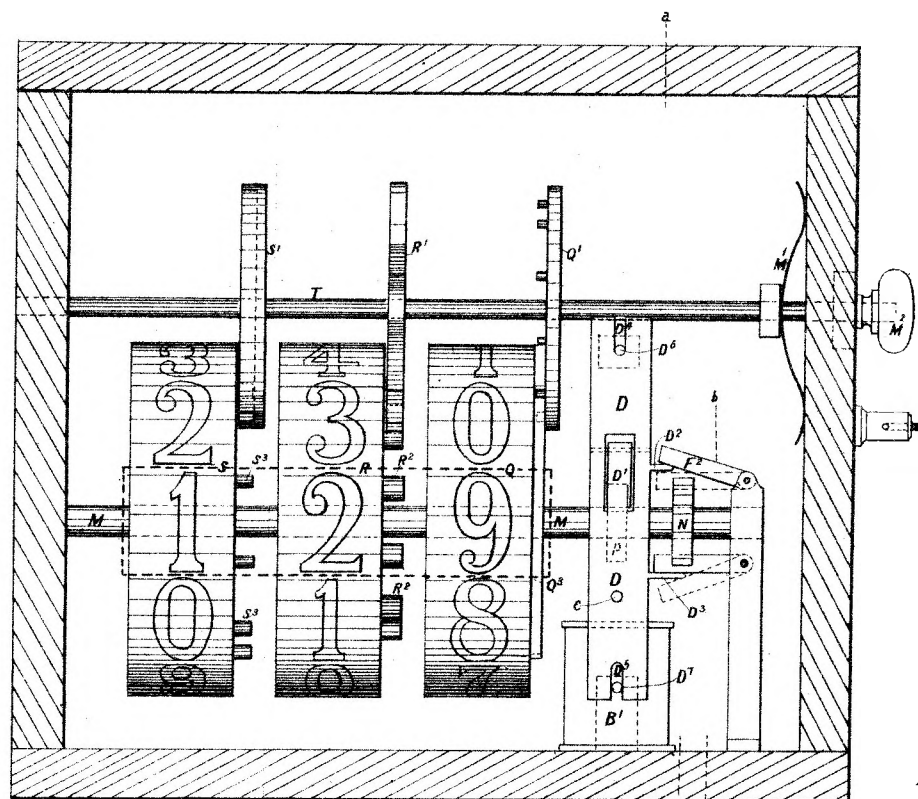


FIG. 6.

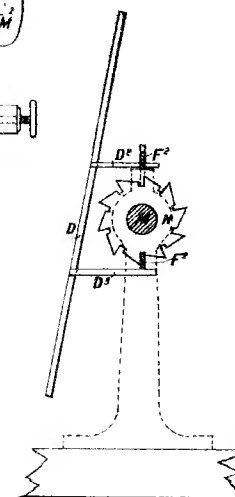


FIG. 8.

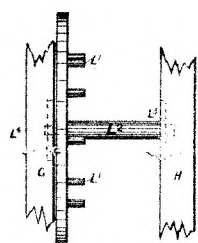


FIG. 3.

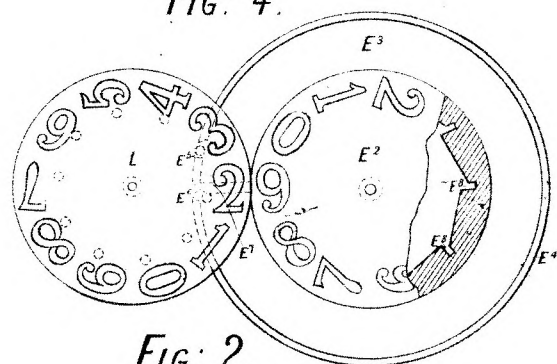


FIG. 2.

A. U. ALCOCK'S PATENT.

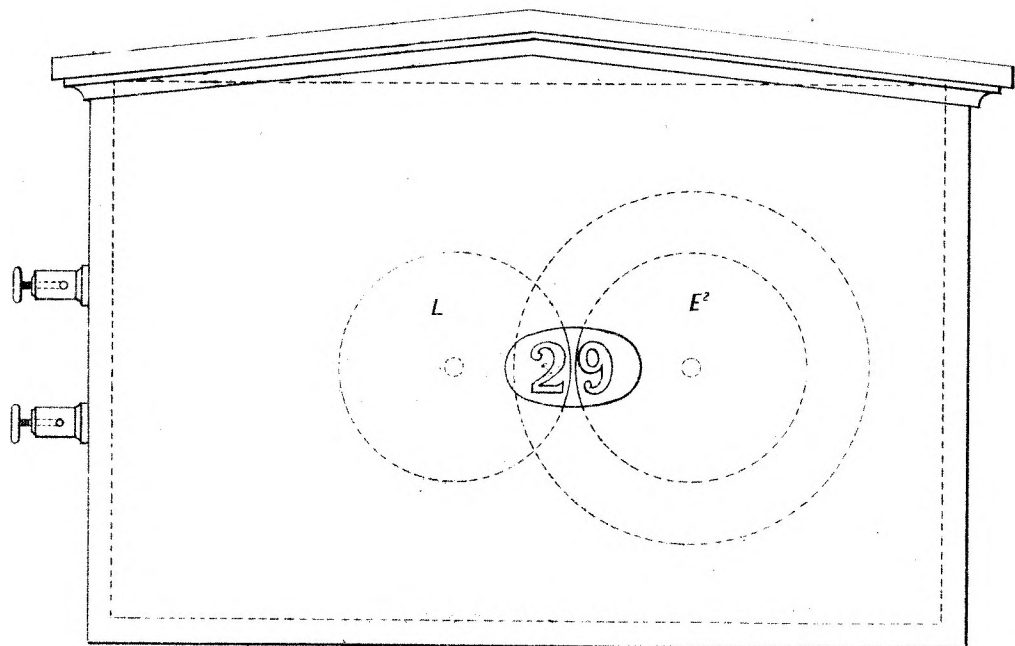


FIG. 1.

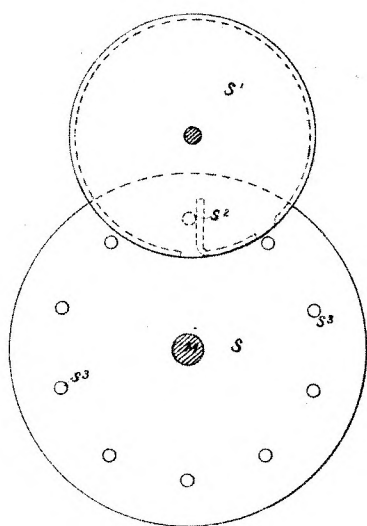


FIG. 10.

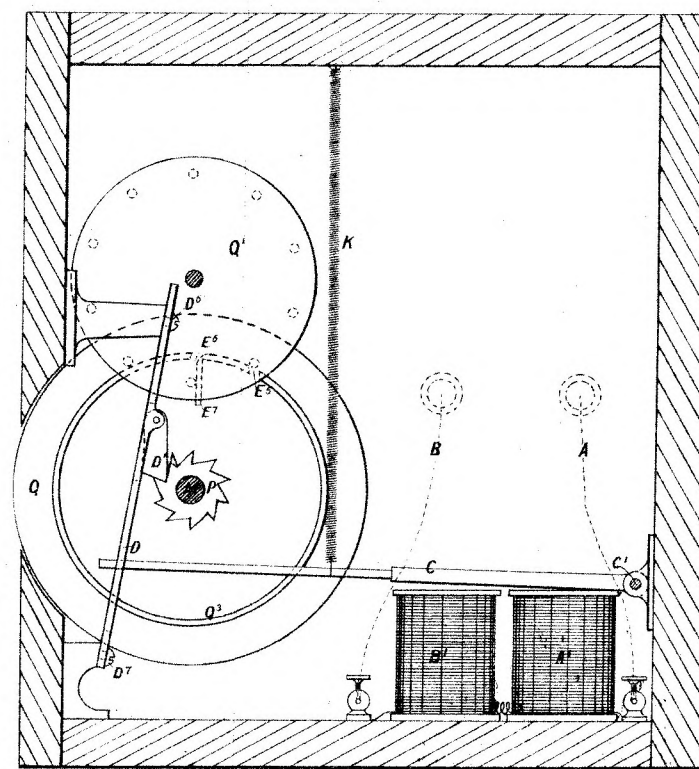


FIG. 7.

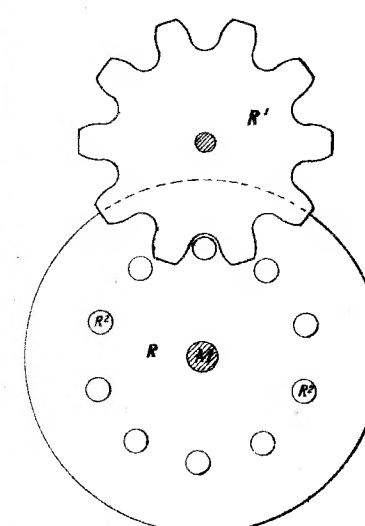


FIG. 9.

This is the Sheet of Drawings referred to in the above Letters of Registration, granted to Alfred Upton Alcock, this Eighteenth day February, A. D. 1884.
Augustus Loftus.

PHOTO-LITHOGRAPHED AT THE GOVT. PRINTING OFFICE, SYDNEY, NEW SOUTH WALES.

(Sig: 245-)



A.D. 1884, 18th February. No. 1396.

E. B. PARNELL'S PYRITE PROCESS NO. 2.

LETTERS OF REGISTRATION to Elizabeth Barnston Parnell, for an invention entitled "E. B. Parnell's Pyrite Process No. 2."

[Registered on the 19th day of February, 1884, in pursuance of the Act 16 Vic. No. 24.]

BY HIS EXCELLENCY THE RIGHT HONORABLE SIR AUGUSTUS WILLIAM FREDERICK SPENCER LOFTUS (commonly called LORD AUGUSTUS LOFTUS), Knight Grand Cross of the Most Honorable Order of the Bath, a Member of Her Majesty's Most Honorable Privy Council, Governor and Commander-in-Chief of the Colony of New South Wales and its Dependencies.

TO ALL TO WHOM THESE PRESENTS SHALL COME, greeting :

WHEREAS ELIZABETH BARNSTON PARNELL, of No. 4, Bourke-street, Redfern, hath by her Petition humbly represented to me that she is the author or designer of a certain invention or improvement in manufactures, that is to say, of an invention entitled "E. B. Parnell's Pyrite Process No. 2," which is more particularly described in the specification and the sheet of drawings which are hereunto annexed ; and that she the said Petitioner hath deposited with the Honorable the Treasurer of the said Colony of New South Wales the sum of Twenty Pounds sterling, for defraying the expense of granting these Letters of Registration, as required by the Act of Council, sixteenth Victoria, number twenty-four : and hath humbly prayed that I would be pleased to grant Letters of Registration, whereby the exclusive enjoyment and advantage of the said invention or improvement might be secured to her for a period of fourteen years : And I, being willing to give encouragement to all inventions and improvements in the arts or manufactures which may be for the public good, and having received a report favourable to the prayer of the said petition, from competent persons appointed by me to examine and consider the matters stated therein and to report thereon for my information, am pleased, with the advice of the Executive Council, and in exercise of the power and authority given to me by the said Act of Council, to grant, and do by these Letters of Registration grant unto the said Elizabeth Barnston Parnell, her executors, administrators, and assigns, the exclusive enjoyment and advantage of the said invention or improvement for and during the term of fourteen years from the date hereof ; to have, hold, and exercise unto the said Elizabeth Barnston Parnell, her executors, administrators, and assigns, the exclusive enjoyment and advantage thereof, for and during and unto the full end and term of fourteen years from the date of these presents next and immediately ensuing, and fully to be complete and ended : Provided always, that if the said Elizabeth Barnston Parnell shall not, within three days after the granting of these Letters of Registration, register the same in the proper office in the Supreme Court, at Sydney, in the said Colony of New South Wales, then these Letters of Registration, and all advantages whatsoever hereby granted, shall cease and become void.

In witness whereof, I have hereunto set my sign manual, and have caused the present Letters of Registration to be sealed with the seal of the said Colony of New South Wales, at Government House, Sydney, in New South Wales, this eighteenth day of February, in the year of our Lord one thousand eight hundred and eighty-four.

[L.S.]

AUGUSTUS LOFTUS.

E. B. Parnell's Pyrites Process No. 2.

TO ALL TO WHOM THESE PRESENTS SHALL COME: I, ELIZABETH BARNSTON PARNELL, of Sydney, in the Colony of New South Wales, send greeting:

WHEREAS I am desirous of obtaining Royal Letters Patent for securing unto me Her Majesty's special license that I, my executors, administrators, and assigns, and such others as I or they shall at any time agree with, and no others, should and lawfully might from time to time and at all times during a period of fourteen years, to be computed from the day on which this instrument shall be left at the office of the Chief Secretary, make, use, exercise, and vend within the Colony of New South Wales and its dependencies an invention for the extraction and saving of various base metals, also of gold and silver, from pyrites and other ores by a mechanical set of inventions, forming one process, to be designated "E. B. Parnell's Pyrites Process No. 2." And in order to obtain the said Royal Letters Patent, I must by an instrument in writing under my hand and seal particularly describe and ascertain the nature of the said invention, and in what manner the same is to be performed, and must also enter into the covenant hereinafter contained: Now, know ye that the nature of the said invention, and the manner in which the same is to be performed, are particularly described and ascertained in and by the following statement, that is to say:—The form of the furnace for the purposes of this invention is an octagon cylinder, which I prefer to be about five feet in diameter, with a length of from thirty-five to sixty feet, more or less, according to capacity required. It may be built of cast iron in two or several sections belted together, or it may be built of boiler plate, as preferred. It is carried on three or more friction wheels gearing into friction rollers fitted into suitable framing of wood or iron. The whole interior length of the furnace is traversed by a hollow girder secured into a stuffing box at other end (on which the body of the furnace revolves) and which also forms the driving wheel or wheels, at one or both ends, as desired. The central girder is divided into two chambers for the purpose of carrying two pipes—one for gas, the other for air. These pipes are inserted at one end. The girder is also divided by another partition about two feet from end of furnace, more or less, forming a chamber for the indraft and escape of fumes through openings into a pipe leading to condenser. The gas-pipe is pierced with holes throughout its whole length at intervals of about 3". That for air (occupying two-thirds of space in girder) is pierced on three sides at intervals of about 4" to alternate with holes on the other sides of girder. The furnace is lined with fire-tiles, as shown in plan; into these eight ridges or shelves of fire-clay are dovetailed; these being tongued and grooved at apex, so that they may slide into each other. They are set at about 90 degrees or thereabout. I provide fuel and discharge doors throughout the whole length of furnace, placed at intervals of about three feet; also two man-holes, or rabble doors, one at either end of furnace. The interior ends of this furnace, also girder and pipes, are built of phosphor bronze or other metal, and the doors are lined with it for the purpose of protecting the iron from fumes. The boiler for this process (No. 2) is similar in form to the furnace, but built of any soft wood, the shelves or ridges being also of wood, the discharge and feed gates placed at intervals of five or six feet; these may be of wood with hinges or bolts of copper or brass; no iron may possibly come in contact with the liquid contained in the boiler. I provide only one man-hole at end. The boiler has no central girder, but is provided with stuffing-boxes similar to the furnace, through one of which a steam pipe is carried into the boiler. The boiler is provided with a safety valve for the escape of steam, also with three or more let-off plug-holes to draw off the water clear from pyrites. I may make this boiler of any dimensions, but I prefer, say, six feet by thirty feet or thereabout. The mode of treatment is as follows:—The pyrites are first ground wet in my patented grinder, then passed on to drying-floor (formed by roof of condenser), thence fed into the furnace or calciner. The gas is turned on and lighted. The calciner is caused to revolve about two revolutions per minute. As soon as the pyrites or ore is well warmed the hot blast is turned on. The temperature must be very moderate for the first hour or two. At the end of two or three hours, according to variety of pyrites being heated, the charge is discharged from the furnace into the cellar, and in case of a portion lodging in furrow it is rabbled out. The ore or pyrites is then carried by a traveller to a second grinder and ground dry, thence fed into another similar calciner in which a much higher temperature is employed. In about two or three hours it is discharged and carried by traveller to the boiler, where it is boiled for about thirty minutes, the water drawn off, pyrites washed twice with hot water, and from the boiler the pyrites is passed into my steam amalgamator for further treatment. The upper sides of cellar under calciner are guarded by iron doors to fold back, resting against sides of furnace when not in motion, to prevent waste of pyrites through being blown about. The furnace is fed from a light iron bridge extending its whole length. Index to plans: Fig. 1—Parts marked A, interior of furnace; B, fireclay, ridges or shelves; C, lining of cylinder; D, blast chamber for air; E, blast chamber for gas; F, friction wheel working on friction rollers G; H, flue for fumes to condenser; I, cellar; J, feed and discharge doors; K, rabble holes; L, pipe for conveying air into air chamber; M, gas pipe for conveying gas into gas chamber; N, outlet for fumes into H; O, stuffing boxes and driving gear. Fig. 2, cross-section of fig. 1, references to similar parts, dotted lines, show position of driving gear. I claim the form of the cylinder in its being octagonal. I claim the form and purposes of the fireclay ridges. I claim the air and gas chamber and its various parts as described for injecting air and gas for the purposes aforesaid. I claim the stuffing boxes in the ends of the cylinder as a means of keeping the cylinder air-tight. I claim the use of heated air under pressure, for the purpose of calcining pyrites or other ore, and as a portion of my method for the recovery of the precious and base metals from their ores. I claim the use of carburetted hydrogen as an agent in the calcining of pyrites. I claim the two machines conjointly, as forming parts of one process. I claim the use of steam under pressure to the boiler. And I do hereby, for myself, my heirs, administrators, and assigns, covenant with Her Majesty, her heirs and successors, that I believe the said invention to be a new invention, as to the public use and exercise thereof; and I do not know or believe that any other person than myself is the true and first inventor of the within-claimed patent; and that I will not leave these presents at the office of the Chief Secretary with any such knowledge or belief as last aforesaid.

In witness whereof, I have hereunto set my hand and seal, this twenty-seventh day of December, one thousand eight hundred and eighty-three.

ELIZABETH BARNSTON PARNELL.

This is the specification referred to in the annexed Letters of Registration granted to Elizabeth Barnston Parnell, this eighteenth day of February, A.D. 1884.

AUGUSTUS LOFTUS.
REPORT.

E. B. Parnell's Pyrites Process No. 2.

REPORT.

Sir, Sydney, 12 January, 1884.
The petition of Mrs. Elizabeth Barnston Parnell for Letters of Registration for an invention entitled "E. B. Parnell's Pyrites Process No. 2," having been referred to us, we have examined the specification and drawings accompanying the same, and have the honor to report that we see no objection to the issue of Letters of Registration as prayed for.

The Under Secretary of Justice.

We have, &c.,
J. SMITH.
A. LEIBIUS.

[Drawings—one sheet.]

No. 1397.

[Assignment of No. 1362. See Letters of Registration for 1884, page 41.]

No. 1398.

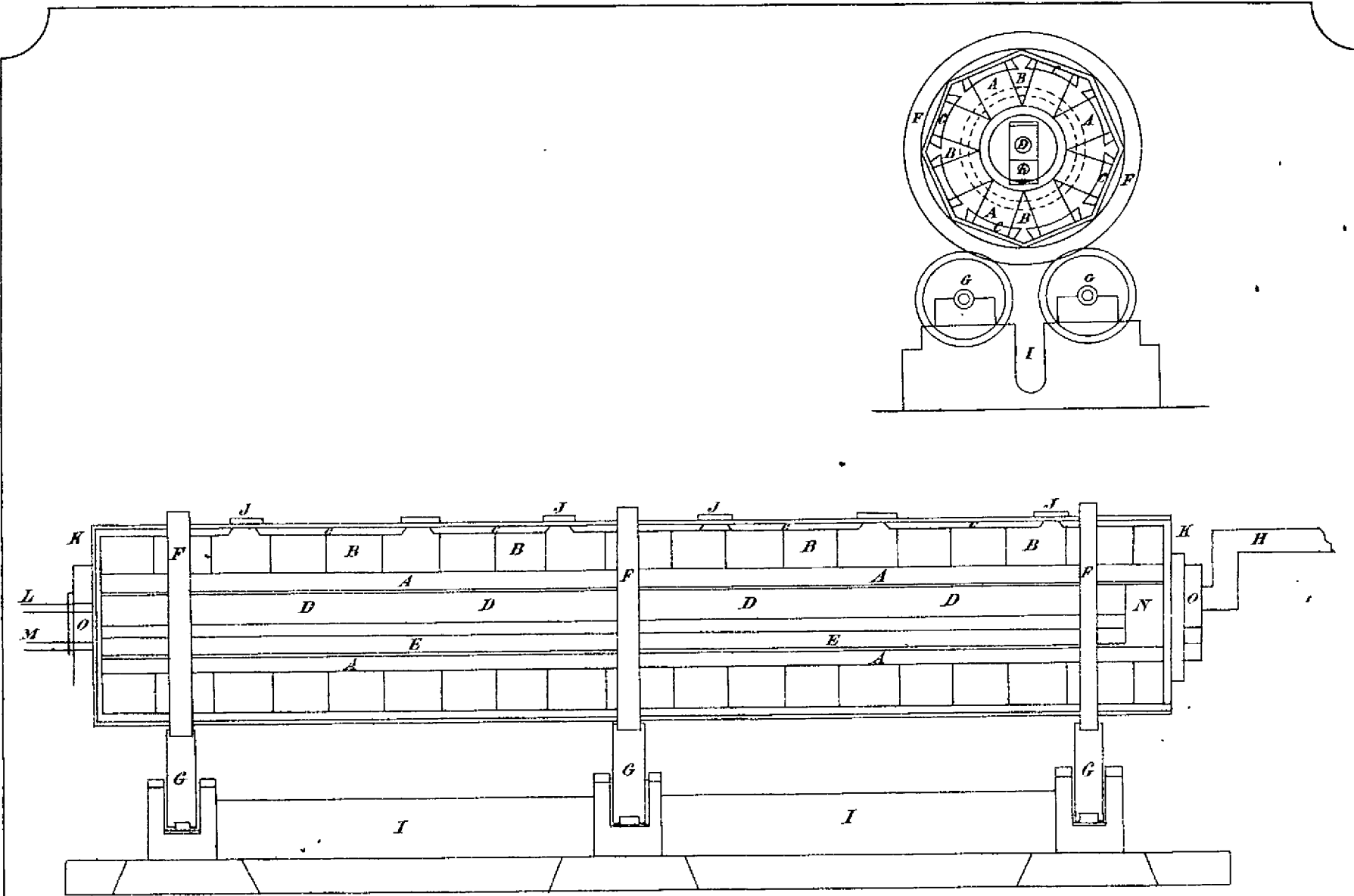
[Assignment of No. 1286. See Letters of Registration for 1883, page 323.]

No. 1399.

[Assignment of No. 1189. See Letters of Registration for 1883, page 49.]

No. 1400.

[Assignment of No. 1191. See Letters of Registration for 1883, page 55.]



*This is the Sheet of Drawings referred to in the annexed Letters of Registration,
granted to Elizabeth Barnston Parnell, this Eighteenth day of February,
A. D., 1864.
Augustus Loftus.*

E. B. Parnell



A.D. 1884, 11th March. No. 1401.

AN IMPROVED METHOD OF CONSTRUCTING POST AND RAIL FENCING.

LETTERS OF REGISTRATION to Martin Lyons, for an improved method of constructing Post and Rail Fencing.

[Registered on the 11th day of March, 1884, in pursuance of the Act 16 Vic. No. 24.]

BY HIS EXCELLENCY THE RIGHT HONORABLE SIR AUGUSTUS WILLIAM FREDERICK SPENCER LOFTUS, (commonly called LORD AUGUSTUS LOFTUS), Knight Grand Cross of the Most Honorable Order of the Bath, a Member of Her Majesty's Most Honorable Privy Council, Governor and Commander-in-Chief of the Colony of New South Wales and its Dependencies.

TO ALL TO WHOM THESE PRESENTS SHALL COME, greeting :

WHEREAS MARTIN LYONS, of Glenhope, near Kyneton, in the Colony of Victoria, farmer, hath by his Petition humbly represented to me that he is the author or designer of a certain invention or improvement in manufactures, that is to say, of an invention entitled "An improved method of constructing Post and Rail Fencing," which is more particularly described in the specification and the sheet of drawings which are hereunto annexed ; and that he, the said Petitioner, hath deposited with the Honorable the Treasurer of the said Colony of New South Wales the sum of Twenty Pounds sterling, for defraying the expense of granting these Letters of Registration, as required by the Act of Council, sixteenth Victoria, number twenty-four ; and hath humbly prayed that I would be pleased to grant Letters of Registration, whereby the exclusive enjoyment and advantage of the said invention or improvement might be secured to him for a period of fourteen years : And I, being willing to give encouragement to all inventions and improvements in the arts or manufactures which may be for the public good, and having received a report favourable to the prayer of the said Petition, from competent persons appointed by me to examine and consider the matters stated therein and to report thereon for my information, am pleased, with the advice of the Executive Council, and in exercise of the power and authority given to me by the said Act of Council, to grant, and do by these Letters of Registration grant unto the said Martin Lyons, his executors, administrators, and assigns, the exclusive enjoyment and advantage of the said invention or improvement, for and during the term of fourteen years from the date hereof ; to have, hold, and exercise unto the said Martin Lyons, his executors, administrators, and assigns, the exclusive enjoyment and advantage thereof, for and during and unto the full end and term of fourteen years from the date of these presents next and immediately ensuing, and fully to be complete and ended : Provided always, that if the said Martin Lyons shall not, within three days after the granting of these Letters of Registration, register the same in the proper office in the Supreme Court, at Sydney, in the said Colony of New South Wales, then these Letters of Registration, and all advantages whatsoever hereby granted, shall cease and become void.

In witness whereof, I have hereunto set my sign manual, and have caused the present Letters of Registration to be sealed with the seal of the said Colony of New South Wales at Government House, Sydney, in New South Wales, this eleventh day of March, in the year of our Lord one thousand eight hundred and eighty-four.

[L.S.]

AUGUSTUS LOFTUS.

An improved method of constructing Post and Rail Fencing.

SPECIFICATION of MARTIN LYONS, of Glenhope, near Kyneton, in the Colony of Victoria, farmer, for an invention entitled "An improved method of constructing Post and Rail Fencing."

My invention relates to post and rail fencing, and consists in a cheap, convenient, and expeditious method of connecting the rails to the posts. Hitherto rails have been mortised into the posts, which involves a somewhat expensive process in making the mortise holes and fitting the rails therein, besides which there is the inconvenience arising from the difficulty of removing one or two panels without straining the adjoining lengths of fencing. Now, I do away with the mortise holes, and instead of them I cut angular recesses on both the front and the back of the posts to receive the ends of the rails, which pass from the front of one post to the back of the next, and from the front of it to the back of the next, and so on, and I fasten the rails to the posts by tying them with a wire. Each wire *must* pass through the post, but need not pass through the rail; it may do so if preferred, but it may also pass around the rails, instead so as to form a loop; the two ends, however, must be brought together at the back or front of the post and there fastened by twisting or otherwise. I prefer that the holes in the post through which the wire is to pass should be so bored as that the wire will pass diagonally from one corner of the recess to the other, as shown in my drawing. By adopting this plan the wires which hold the rails in position will also act as a binder for the post, and tend to prevent its splitting, either from gum veins therein or other causes, in addition to which the post can be of much smaller section and, according to one modification, of less length than is now the case.

In order, however, that my invention may be clearly understood, I will now refer to the drawings hereto attached, in which fig. 1 shows my fence in elevation, one half showing the front of a post and the other half showing the back of a post. Fig. 2 is a plan, fig. 3 an end view of my fence, and fig. 4 shows a portion of a post and rail of another modification of my invention. In these figs. AA are the posts having the angular recesses A¹ cut in them to receive the rails B, which are tapered at their ends so as to form a flat surface for the tying wire C to rest upon. It will be seen that three methods of placing the wire C for binding the rails to the posts are shown in the drawing. In the top rail the holes for the reception of the tying wire C are bored through the rails and the posts. In the middle rail the holes are bored through the posts clear of the rails, and in the lower one the top hole is bored through the post clear of the rail, and the bottom one passes through both rail and post. In fig. 4 another modification of my invention is shown, in which the ends of the rails are reduced in width so as to bring the top of post and it to about a level, thus saving several inches in the length of the posts, which is very desirable. In fixing them together the two ends of the wire are passed through these holes from the one side of the fence, and the ends are then twisted or tied at the other side, as shown by C¹, thereby firmly binding the rails to and in the recesses of the posts.

Of course there may be many modifications of my invention. First of all, the rails on one panel may be in front of the posts and the next panel at the back of the posts, although I prefer the rails with one end in front of the posts and the other at the back of them, as shown. The wires also may be passed through the posts and the ends fastened together in many ways, but in this respect I prefer to use the method shown in fastening the middle rails, fig. 1, and also the top rails, fig. 4, in my drawings. What I believe to be new, and therefore claim as my improved method of constructing post and rail fencing, is—

First—Binding the rails B to the post A (having recesses cut in them) by means of a wire C, which passes around, or partially around, the rails and through the posts, and is tied by being twisted or otherwise in such position, substantially as herein described and as illustrated in the drawings.

Second—Arranging each panel or set of rails between the posts by fixing the one end at the front of one post and the other end at the back of the adjoining post in combination with the before-mentioned means of binding them together with a wire, substantially as herein described and explained.

In witness whereof, I, the said Martin Lyons, have hereto set my hand and seal, this eighth day of January, one thousand eight hundred and eighty-four.

Witness—

THOMAS DWYER.

MARTIN LYONS.

This is the specification referred to in the annexed Letters of Registration granted to Martin Lyons, this eleventh day of March, A.D. 1884.

AUGUSTUS LOFTUS.

REPORT.

Sir,

The application of Mr. Martin Lyons for Letters of Registration for "An improved method of constructing Post and Rail Fencing" having been referred to us, we have examined the plans and specification accompanying the same, and have now the honor to report that we see no objection to the issue of Letters of Registration as prayed for.

We have, &c.,

JAMES BARNET.

EDMUND FOSBERY.

The Under Secretary of Justice.

[Drawings—one sheet.]

No. 1402.

[Assignment of No. 1191. See Letters of Registration for 1883, page 55.]

M. LYONS' PATENT

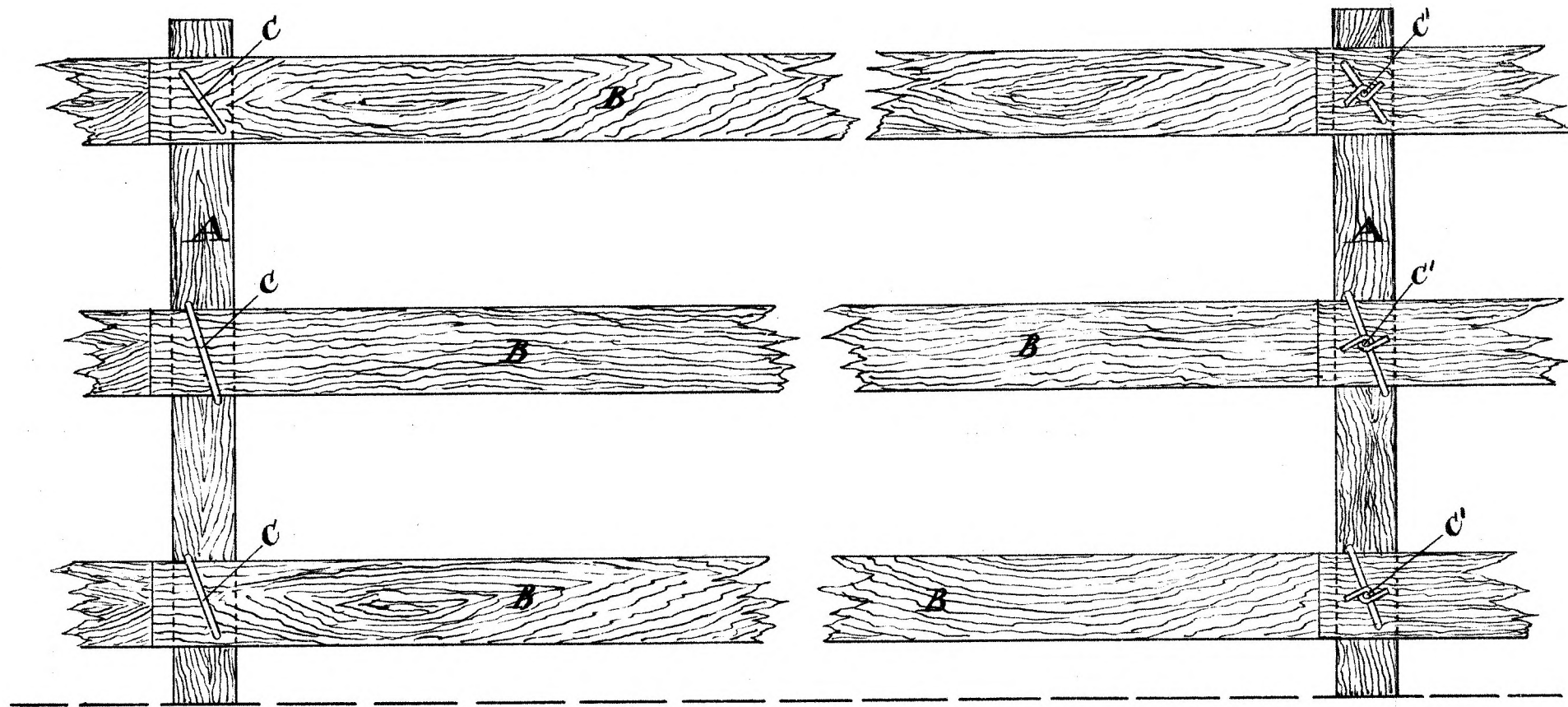


Fig: 1.

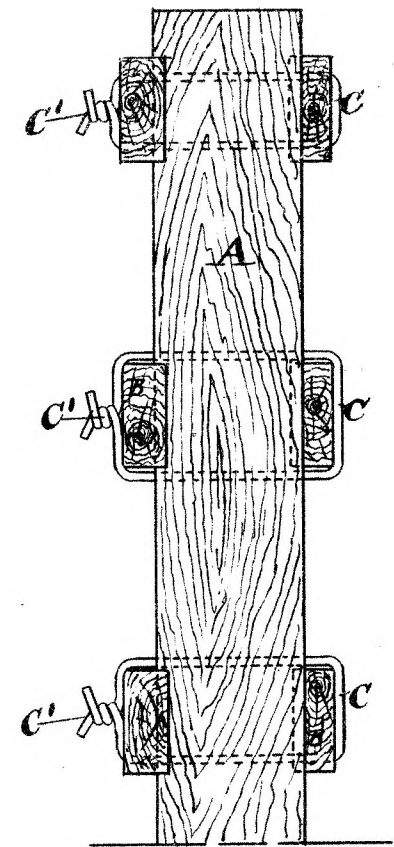


Fig: 3.

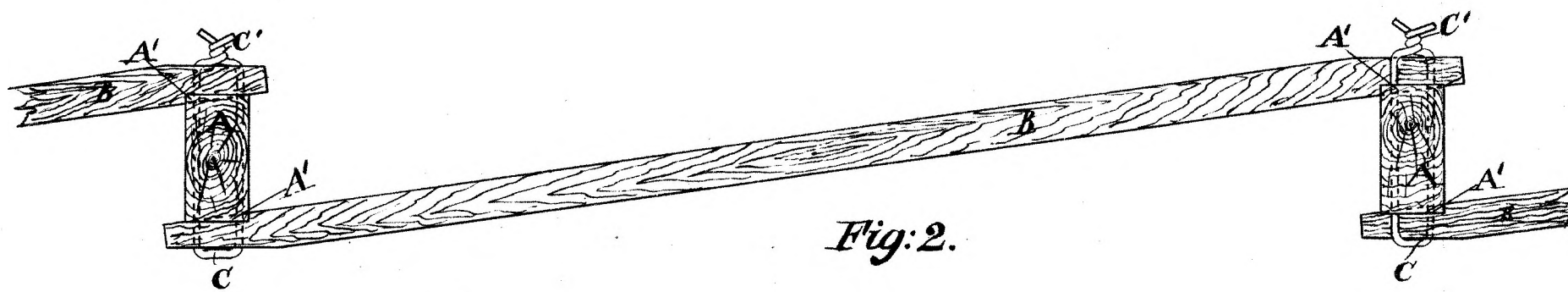


Fig: 2.

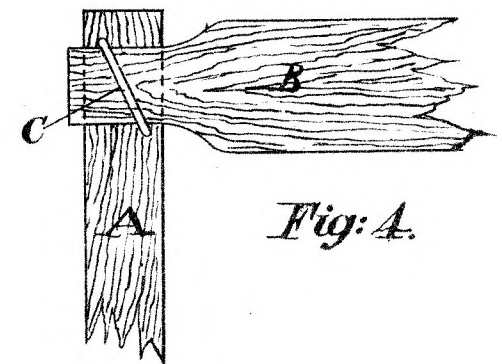


Fig: 4.

(Sig. 245-)

This is the Sheet of Drawings referred to in the annexed Letters of Registration granted to Martin Lyons, this eleventh day of March, A.D. 1884.

Augustus Loftus.



A.D. 1884, 18th March. No. 1403.

AN IMPROVEMENT IN THE PREVENTION AND REMOVAL OF SCALE IN STEAM-BOILERS.

LETTERS OF REGISTRATION to George Downie, for an Improvement in the Prevention and Removal of Scale in Steam-boilers.

[Registered on the 18th day of March, 1884, in pursuance of the Act 16 Vic. No. 24.]

BY HIS EXCELLENCY THE RIGHT HONORABLE SIR AUGUSTUS WILLIAM FREDERICK SPENCER LOFTUS (commonly called LORD AUGUSTUS LOFTUS), Knight Grand Cross of the Most Honorable Order of the Bath, a Member of Her Majesty's Most Honorable Privy Council, Governor and Commander-in-Chief of the Colony of New South Wales and its Dependencies.

TO ALL TO WHOM THESE PRESENTS SHALL COME, greeting :

WHEREAS GEORGE DOWNIE, of Salinas, County of Monterey, State of California, one of the United States of America, gentleman, hath by his Petition humbly represented to me that he is the author or designer of a certain invention or improvement in manufactures, that is to say, of an invention entitled "An Improvement in the Prevention and Removal of Scale in Steam-boilers," which is more particularly described in the specification which is hereunto annexed ; and that he, the said Petitioner, hath deposited with the Honorable the Treasurer of the said Colony of New South Wales the sum of Twenty Pounds sterling, for defraying the expense of granting these Letters of Registration, as required by the Act of Council, sixteenth Victoria, number twenty-four ; and hath humbly prayed that I would be pleased to grant Letters of Registration, whereby the exclusive enjoyment and advantage of the said invention or improvement might be secured to him for a period of fourteen years : And I, being willing to give encouragement to all inventions and improvements in the arts or manufactures which may be for the public good, and having received a report favourable to the prayer of the said Petition, from competent persons appointed by me to examine and consider the matters stated therein and to report thereon for my information, am pleased, with the advice of the Executive Council, and in exercise of the power and authority given to me by the said Act of Council, to grant, and do by these Letters of Registration grant unto the said George Downie, his executors, administrators, and assigns, the exclusive enjoyment and advantage of the said invention or improvement, for and during the term of fourteen years from the date hereof ; to have, hold, and exercise unto the said George Downie, his executors, administrators, and assigns, the exclusive enjoyment and advantage thereof, for and during and unto the full end and term of fourteen years from the date of these presents next and immediately ensuing, and fully to be complete and ended : Provided always, that if the said George Downie shall not, within three days after the granting of these Letters of Registration, register the same in the proper office in the Supreme Court at Sydney, in the said Colony of New South Wales, then these Letters of Registration, and all advantages whatsoever hereby granted, shall cease and become void.

In witness whereof, I have hereunto set my sign manual, and have caused the present Letters of Registration to be sealed with the seal of the said Colony of New South Wales, at Government House, Sydney, in New South Wales, this eighteenth day of March, in the year of our Lord one thousand eight hundred and eighty-four.

[L.S.]

AUGUSTUS LOFTUS.

An Improvement in the Prevention and Removal of Scale in Steam-boilers.

SPECIFICATION of GEORGE DOWNIE, of Salinas, County of Monterey, State of California, one of the United States of America, gentleman, for an invention entitled "An Improvement in the Prevention and Removal of Scale in Steam-boilers."

My invention relates to an improvement in the prevention and removal of scale in steam-boilers.

It consists in introducing into the boiler an infusion, decoction, or other preparation of eucalyptus, either the wood, bark, leaves, blossoms, and capsules, or any portion which will produce the desired effect, said infusion either made separately and afterwards introduced into the boiler, or prepared within the boiler itself, so as to remove any scale which may have been already formed, or to so effect the water as to prevent the incrustation of the boiler by any substance which may be held in solution or suspension in the water which is used in the boiler, and at the same time avoid any injurious effects to the shell of the boiler.

There are many modes of applying the eucalyptus, such as boiling the leaves or other parts, making a cold infusion, or in other ways extracting the desired substance, which may afterwards be introduced to the boiler as required, either with the feed-water or by a cup or chamber, into which it may be placed, and by suitable cocks admitted to the boiler; or the leaves or other parts may be placed in a perforated tube, basket, or chamber, which can be introduced into the boiler through a hand-hole or other opening, so that the water will act directly upon the material and extract the valuable portion.

In some cases where there is a heater connected with the boiler, I put the eucalyptus into the hot water which accumulates within the tank, and the infusion thus made is sent to the boiler by the feed-pump or other apparatus. By this means the heated water intended for use within the boiler is impregnated with the properties of the eucalyptus, and is thus caused to part with the scale-forming substances, which are deposited in a harmless form and prevented from settling as scale.

In case no heater is employed the eucalyptus may be placed directly into the boiler, or an infusion may be made separately, and then supplied to the boiler when needed, as before described.

If the eucalyptus, in the form of leaves or fine twigs, be placed directly in the boiler it will be preferable to enclose it in a basket or network of some convenient description to prevent its becoming scattered, and so that it may be easily removed when it becomes spent.

The charge to be used and the frequency of its renewal will depend upon the size of the boiler and the character of the water used, this being easily determined by inspection.

I am aware that there is tannin or tannic acid inherent in the eucalyptus, and I am also aware that tannic acid in various forms has been used to remove scales from boilers; I am also aware that it is a well-recognized fact that tannic acid when used for any such purpose materially injures the boiler in the absence of any other element to counteract the effect of the tannic acid on the metal after it has performed its work on the crustation. I do not pretend to set up in this specification any theory regarding the chemical action of the eucalyptus, but I have demonstrated by long continuous and exhaustive experiments that the eucalyptus will remove scale from boilers, and keep them free from scale, without injuring their shell.

Having thus described my improvement in the prevention and removal of scale in steam-boilers, what I claim as new and of my invention is—

Subjecting the interior of steam-boilers to the action of an infusion or decoction of eucalyptus, substantially as and for the purpose described.

In witness whereof, I, the said George Downie have hereto set my hand and seal this twenty-fourth day of January, one thousand eight hundred and eighty-four.

Witness—

W. S. BAYSTON,
Patent Law Clerk, Melbourne.

GEORGE DOWNIE,
(By his Attorney, EDWD. WATERS).

This is the specification referred to in the annexed Letters of Registration granted to George Downie, this eighteenth day of March, A.D. 1884.

AUGUSTUS LOFTUS.

REPORT.

Sir,

In reply to your letter of the 29th ultimo, we have the honor to report that we have examined Mr. George Downie's application for Letters of Registration for an invention entitled "Improvements in the prevention and removal of Scale in Steam boilers," also the specification therewith, and see no reason why his application should not be granted.

We have, &c.,

FRANCIS HIXSON.
H. BRODERICK.

The Under Secretary of Justice.

Sydney, 1 February, 1884.



A.D. 1884, 18th March. No. 1404.

IMPROVEMENTS IN HARVESTING MACHINES.

LETTERS OF REGISTRATION to Bernhard Samuelson, for Improvements in Harvesting Machines.

[Registered on the 18th day of March, 1884, in pursuance of the Act 16 Vic. No. 24.]

BY HIS EXCELLENCY THE RIGHT HONORABLE SIR AUGUSTUS WILLIAM FREDERICK SPENCER LOFTUS (commonly called LORD AUGUSTUS LOFTUS), Knight Grand Cross of the Most Honorable Order of the Bath, a Member of Her Majesty's Most Honorable Privy Council, Governor and Commander-in-Chief of the Colony of New South Wales and its Dependencies.

TO ALL TO WHOM THESE PRESENTS SHALL COME, greeting:

WHEREAS BERNHARD SAMUELSON, of Banbury, in the County of Oxford, in England, engineer, hath by his Petition humbly represented to me that he is the author or designer of a certain invention or improvement in manufactures, that is to say, of an invention entitled "Improvements in Harvesting Machines," which is more particularly described in the specification and the sheet of drawings which are hereunto annexed; and that he, the said Petitioner, hath deposited with the Honorable the Treasurer of the said Colony of New South Wales the sum of Twenty Pounds sterling, for defraying the expense of granting these Letters of Registration, as required by the Act of Council, sixteenth Victoria, number twenty-four; and hath humbly prayed that I would be pleased to grant Letters of Registration, whereby the exclusive enjoyment and advantage of the said invention or improvement might be secured to him for a period of fourteen years: And I, being willing to give encouragement to all inventions and improvements in the arts or manufactures which may be for the public good, and having received a report favourable to the prayer of the said Petition from competent persons appointed by me to examine and consider the matters stated therein and to report thereon for my information, am pleased, with the advice of the Executive Council, and in exercise of the power and authority given to me by the said Act of Council, to grant, and do by these Letters of Registration grant unto the said Bernhard Samuelson, his executors, administrators, and assigns, the exclusive enjoyment and advantage of the said invention or improvement, for and during the term of fourteen years from the date hereof; to have, hold, and exercise unto the said Bernhard Samuelson, his executors, administrators, and assigns, the exclusive enjoyment and advantage thereof, for and during and unto the full end and term of fourteen years from the date of these presents next and immediately ensuing, and fully to be complete and ended: Provided always, that if the said Bernhard Samuelson shall not, within three days after the granting of these Letters of Registration, register the same in the proper office in the Supreme Court, at Sydney, in the said Colony of New South Wales, then these Letters of Registration, and all advantages whatsoever hereby granted, shall cease and become void.

In witness whereof, I have hereunto set my sign manual, and have caused the present Letters of Registration to be sealed with the seal of the said Colony of New South Wales, at Government House, Sydney, in New South Wales this eighteenth day of March, in the year of our Lord one thousand eight hundred and eighty-four.

[L.S.]

AUGUSTUS LOFTUS.

Improvements in Harvesting Machines.

SPECIFICATION of BERNHARD SAMUELSON, of Banbury, in the County of Oxford, in England, engineer, for an invention entitled "Improvements in harvesting machines."

My invention relates to harvesting machines in which the crop after having been cut falls on to a platform to the rear of the cutting device, whence it is removed to a binding device, and it consists of the combination with a stationary lateral receiver of an apron or belts or links mounted on top and bottom rollers, the said rollers being at right angles or nearly so to the cutter bar, and one or more of the rollers being driven by convenient gearing from the main driving wheel or wheels. The rollers give motion to the apron belts or links, and cause the lower part thereof to remove or assist in removing the crop from the inner side of the rearward platform to the said lateral receiver.

The rearward platform may or may not be extended so far that the lower part of the apron shall lie over it.

The crop, in the course of its removal, or on having been so removed, is taken hold of by packers or lifters placed above the receiver, and by them delivered to any convenient arrangement for forming or completing the sheaf.

DESCRIPTION OF THE DRAWINGS.

Figure 1 is a plan and figure 2 is a back elevation of a harvesting machine in which the grain, after having been cut in the usual way, by the cutter bar A, falls on to an endless apron B, which removes the cut grain to the stationary receiver C. From this receiver it is taken by packers DD and delivered to the binding device, where it is bound and subsequently discharged on to the ground.

In order to assist in removing the cut crop from the rearward platform or apron B, an apron or belts EE is used (in the drawing an apron is shown). This apron is mounted on top and bottom rollers FF, one or both of which is driven by convenient gearing from the main driving wheel and the rollers FF, giving motion to the apron or belts EE, causes it to assist in removing the cut crop from the rearward platform B to the stationary lateral receiver C. As shown in the drawing, the rearward platform extends only as far as the lower part of the apron EE, and auxiliary packers or lifters, C¹, C², C³, are employed to assist in the removal of the crop, but it may be extended further towards the lateral receiver G, so that the apron EE shall be over it.

What I claim as my invention is the combination of the apron or its equivalent with a stationary lateral receiver, the latter being so placed that the grain to be bound is removed from it by packers or lifters placed above the same, as and for the purpose described.

In witness whereof, I, the said Bernard Samuelson, have hereto set my hand and seal, this twenty-first day of January, one thousand eight hundred and eighty-four.

BERNHARD SAMUELSON,
(By his Agent, EDWD. WATERS).

Witness—

W. S. BAYSTON,
Patent Law Clerk, Melbourne.

This is the specification referred to in the annexed Letters of Registration granted to Bernard Samuelson, this eighteenth day of March, A.D. 1884.

AUGUSTUS LOFTUS.

REPORT.

Sir,

Having examined the specification and plans accompanying the petition of Mr. Bernard Samuelson for an invention entitled "Improvements in harvesting machines," we are of opinion that the prayer of the petitioner may be granted.

The Under Secretary of Justice.

Sydney, 30 January, 1884.

We have, &c.,

EDMUND FOSBERY,
JAMES BARNET.

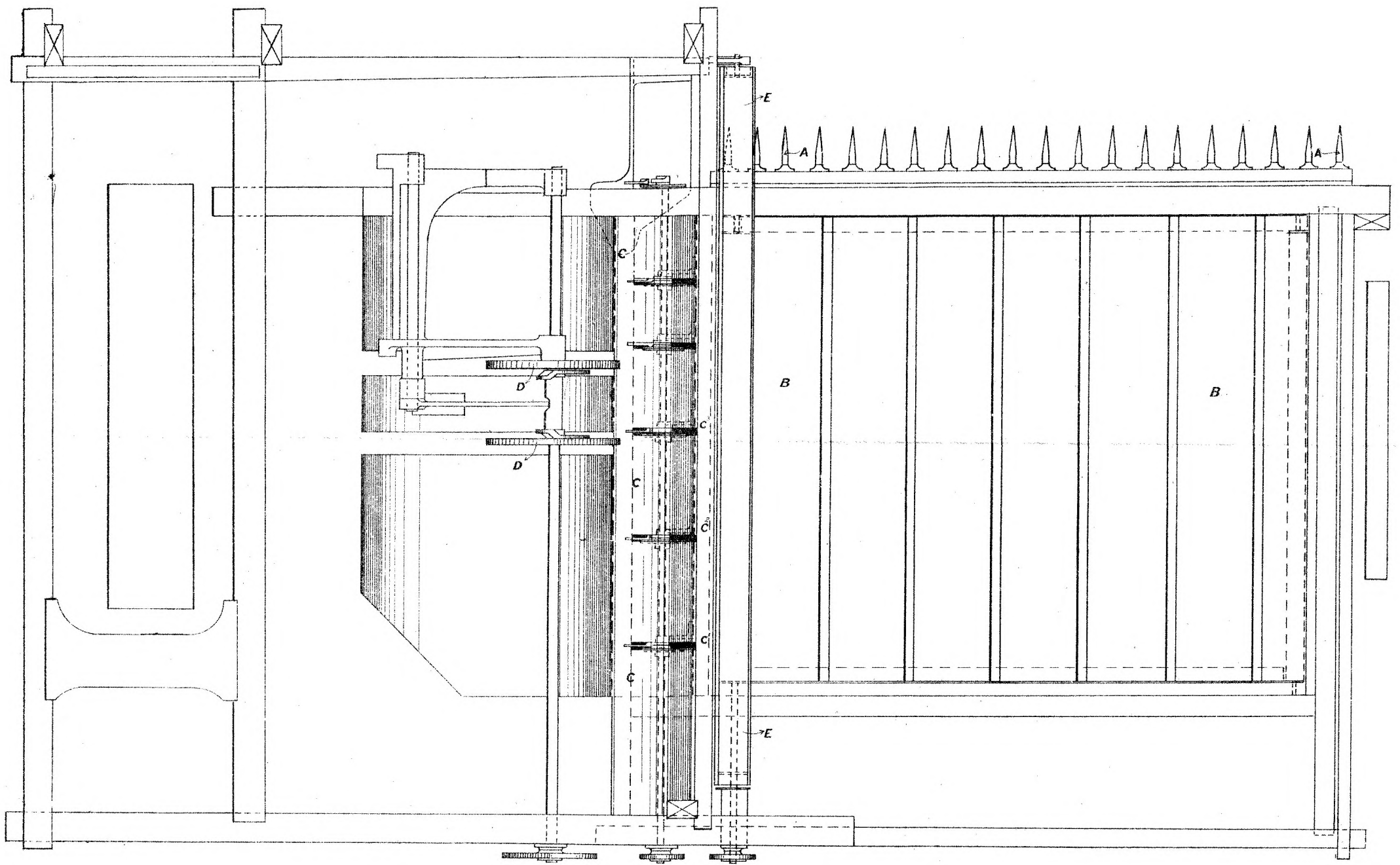


FIG: 1.

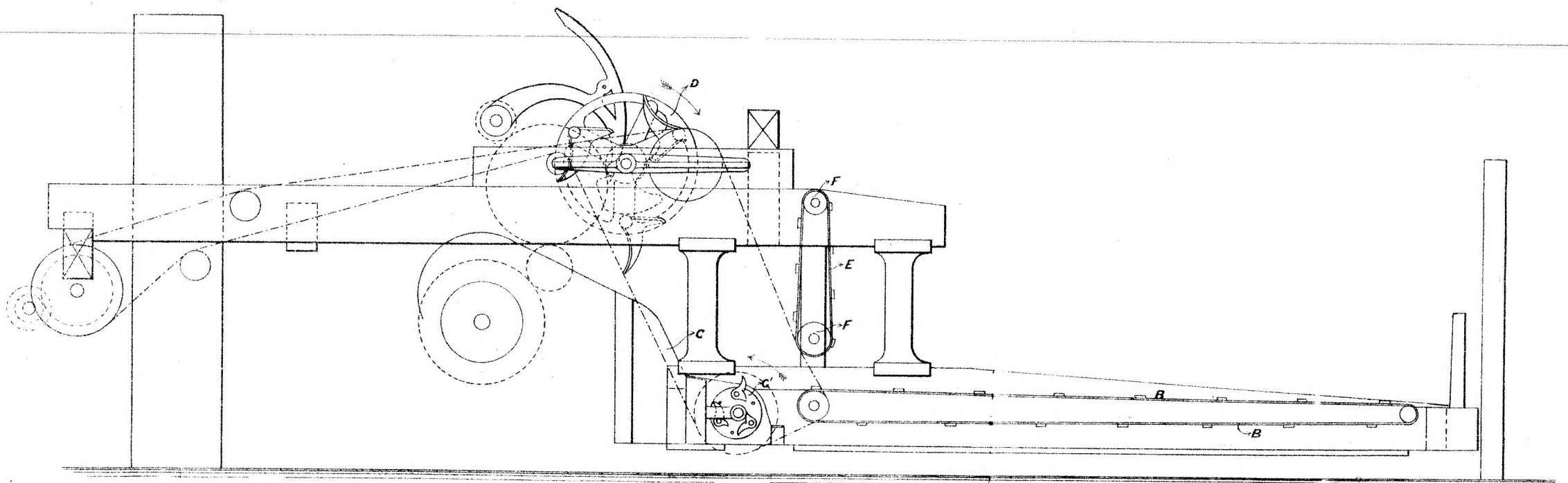


FIG: 2.

*This is the Sheet of Drawings referred to in the annexed
Letters of Registration granted to Bernhard Samuelson,
this eighteenth day of March, A.D. 1884.*

Augustus Loftus.

PHOTO-LITHOGRAPHED AT THE GOVT. PRINTING OFFICE,
SYDNEY, NEW SOUTH WALES.

(516245)



A.D. 1884, 18th March. No. 1405.

IMPROVEMENTS IN STEAM-BOILERS.

LETTERS OF REGISTRATION to Thomas Constantine Fawcett, for Improvements in apparatus for the prevention of explosions and other derangements in Steam-boilers.

[Registered on the 18th day of March, 1884, in pursuance of the Act 16 Vic. No. 24.]

BY HIS EXCELLENCY THE RIGHT HONORABLE SIR AUGUSTUS WILLIAM FREDERICK SPENCER LOFTUS (commonly called LORD AUGUSTUS LOFTUS), Knight Grand Cross of the Most Honorable Order of the Bath, a Member of Her Majesty's Most Honorable Privy Council, Governor and Commander-in-Chief of the Colony of New South Wales and its Dependencies.

TO ALL TO WHOM THESE PRESENTS SHALL COME, greeting :

WHEREAS THOMAS CONSTANTINE FAWCETT, of Leeds, England, engineer, hath by his Petition humbly represented to me that he is the author or designer of a certain invention or improvement in manufactures, that is to say, of an invention entitled "Improvements in Apparatus for the Prevention of explosions and other derangements in Steam-boilers," which is more particularly described in the specification and the sheet of drawings which are hereunto annexed ; and that he, the said Petitioner, hath deposited with the Honorable the Treasurer of the said Colony of New South Wales the sum of Twenty Pounds sterling, for defraying the expense of granting these Letters of Registration, as required by the Act of Council, sixteenth Victoria, number twenty-four ; and hath humbly prayed that I would be pleased to grant Letters of Registration, whereby the exclusive enjoyment and advantage of the said invention or improvement might be secured to him for a period of fourteen years : And I, being willing to give encouragement to all inventions and improvements in the arts or manufactures which may be for the public good, and having received a report favourable to the prayer of the said Petition, from competent persons appointed by me to examine and consider the matters stated therein and to report thereon for my information, am pleased, with the advice of the Executive Council, and in exercise of the power and authority given to me by the said Act of Council, to grant, and do by these Letters of Registration grant unto the said Thomas Constantine Fawcett, his executors, administrators, and assigns, the exclusive enjoyment and advantage of the said invention or improvement, for and during the term of fourteen years from the date hereof ; to have, hold, and exercise unto the said Thomas Constantine Fawcett, his executors, administrators, and assigns, the exclusive enjoyment and advantage thereof, for and during and unto the full end and term of fourteen years from the date of these presents next and immediately ensuing, and fully to be complete and ended : Provided always, that if the said Thomas Constantine Fawcett shall not, within three days after the granting of these Letters of Registration, register the same in the proper office in the Supreme Court, at Sydney, in the said Colony of New South Wales, then these Letters of Registration, and all advantages whatsoever hereby granted, shall cease and become void.

In witness whereof, I have hereunto set my sign manual, and have caused the present Letters of Registration to be sealed with the seal of the said Colony of New South Wales, at Government House, Sydney, in New South Wales, this eighteenth day of March, in the year of our Lord one thousand eight hundred and eighty-four.

[L.S.]

AUGUSTUS LOFTUS.

Improvements in Steam-boilers.

SPECIFICATION of THOMAS CONSTANTINE FAWCETT, of Leeds, England, engineer, for an invention entitled "Improvements in apparatus for the prevention of explosions and other derangements in Steam-boilers."

This invention relates to apparatus for preventing boiler explosions arising from excessive steam pressure, and also other derangements which are liable to happen when the water in the boiler is above or below the high or low water line. The apparatus consists of a dead-weight safety valve placed in the roof of the boiler, enclosed within a steam chest. A steam pipe from the said chest is carried into the flue above the furnace or grate bars, either inside or outside the boiler, so that any steam escaping through the safety valve is discharged upon the coal or fuel, and checks the combustion thereof, and so reduces the quantity of steam generated.

For indicating high and low water we place a pair of levers in the water space, to one of which is attached a float in such a manner that when the float rises or lowers to a certain extent one or other of the levers shall act on the weight of the safety valve and raise the same, thereby allowing steam to escape into the furnace. When the safety valve is heavily weighted a secondary valve may be used for indicating the level of the water.

In order that my invention may be better understood, I herein give reference to the accompanying sheet of drawings, wherein figure 1 is longitudinal section of a steam boiler and furnace, with my improvements applied thereto. A is the furnace placed within the flue; B and C is the shell of the boiler, all arranged in the usual manner. A steam chest D is fixed on the upper part of the boiler, and is in direct communication with the furnace by means of the pipe E. A weighted valve F is employed, placed in the roof of the boiler, and enclosed within the steam chest. It will be understood that when there is excessive pressure of steam in the boiler that the valve F will be opened, thereby allowing steam to escape into the chest D, and pass down the pipe E into the furnace, and thus reduce the heat thereof and diminish the quantity of steam. By this means explosions by undue steam pressure are avoided. The same apparatus as above described can with equal advantage be employed to check the generation of steam when water in the boiler is above or below the estimated water line.

In addition to the apparatus already described, employ an arrangement of compound levers (see figure 2), consisting of a horizontal lever H passing through an opening in the weight I. Another lever J is employed, hinged upon the fulcrum M, and having at one end a float N, which is raised or lowered according to the varying height of water in the boiler.

It will be seen and easily understood that when water is low in the boiler the float N will be lowered also to such an extent as to bring the projecting point A of the lever J underneath the weight I, whereby the valve F is opened, allowing steam to enter the steam chest and pass down the pipe E into the furnace. On the other hand, if the water is too high the lever and float will ascend as shown in dotted line, the pin b on the said lever J being brought into contact with the lever H, which raises the weight and opens the valve, as before explained. Having now shown and described my invention, and the manner of carrying same into practice, I would have it understood that I do not confine myself to the exact details herein shown and described, as the same may be varied without departing from the nature of my invention. The valve F and pipe E, for instance, need not necessarily be on the top of the boiler, but may be placed in any convenient position, providing the orifice of the pipe is in communication with the fire; but what I consider new, and therefore claim as my invention, is—

Firstly—The combination of the valve F, steam chest D, and pipe E, for purposes substantially as shown and described.

Secondly—The use and employment of the compound levers H and J in combination with parts F, D, and E, for the purpose substantially as shown and described.

In witness whereof, I, the said Thomas Constantine Fawcett, have hereunto set my hand and seal, this eighteenth day of September, in the year of our Lord one thousand eight hundred and eighty-three.

Witness—

ALFRED GRAYSON,

Clerk, 3, Rock-place, Leeds.

THOS. C. FAWCETT.

This is the specification referred to in the annexed Letters of Registration granted to Thomas Constantine Fawcett, this 18th day of March, A.D. 1884.

AUGUSTUS LOFTUS.

REPORT.

Sir,

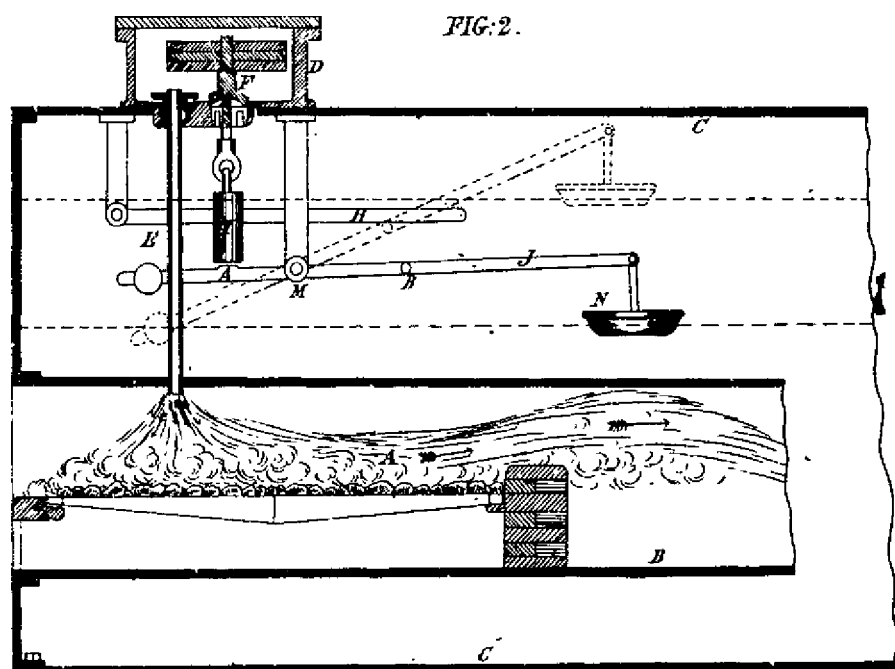
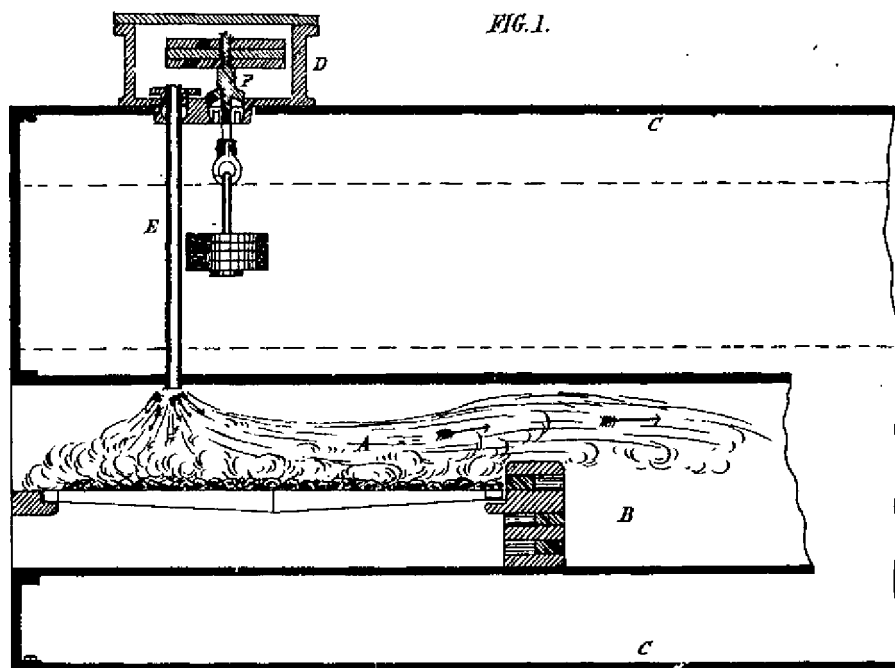
Sydney, 1 February, 1884.

In reply to your letter of the 29th ultimo, we have the honor to report that we have examined Thomas C. Fawcett's application for Letters of Registration for an invention entitled "Improvements in apparatus for the prevention of explosions and other derangements in Steam-boilers," also the specification and drawings therewith, and see no reason why his application should not be granted.

We have, &c.,

FRANCIS HIXSON.
H. BRODERICK.

The Under Secretary of Justice.



This is the Sheet of Drawings referred to in the annexed Letters of Registration granted to Thomas Constantine Farrett, this Eighteenth day of March, A. D., 1834.

Augustus Loftus.



A.D. 1884, 16th April. No. 1406.

IMPROVEMENTS IN ARRESTING SPARKS FROM STEAM-ENGINES.

LETTERS OF REGISTRATION to Robert Henry Firth, for Improvements in Apparatus for Arresting Sparks from Steam-engines.

[Registered on the 18th day of April, 1884, in pursuance of the Act 16 Vic. No. 24.]

BY HIS EXCELLENCY THE RIGHT HONORABLE SIR AUGUSTUS WILLIAM FREDERICK SPENCER LOFTUS (commonly called LORD AUGUSTUS LOFTUS), Knight Grand Cross of the Most Honorable Order of the Bath, a Member of Her Majesty's Most Honorable Privy Council, Governor and Commander-in-Chief of the Colony of New South Wales and its Dependencies.

TO ALL TO WHOM THESE PRESENTS SHALL COME, greeting :

WHEREAS ROBERT HENRY FIRTH, of Tenandra, Martaguy Creek, in the Colony of New South Wales, engineer, hath by his Petition humbly represented to me that he is the author or designer of a certain invention or improvement in manufactures, that is to say, of an invention entitled "Improvements in Apparatus for Arresting Sparks from Steam-engines," which is more particularly described in the specification and the sheet of drawings which are hereunto annexed ; and that he, the said Petitioner, hath deposited with the Honorable the Treasurer of the said Colony of New South Wales the sum of Twenty Pounds sterling, for defraying the expense of granting these Letters of Registration, as required by the Act of Council, sixteenth Victoria, number twenty-four ; and hath humbly prayed that I would be pleased to grant Letters of Registration, whereby the exclusive enjoyment and advantage of the said invention or improvement might be secured to him for a period of fourteen years : And I, being willing to give encouragement to all inventions and improvements in the arts or manufactures which may be for the public good, and having received a report favourable to the prayer of the said Petition, from competent persons appointed by me to examine and consider the matters stated therein and to report thereon for my information, am pleased, with the advice of the Executive Council, and in exercise of the power and authority given to me by the said Act of Council, to grant, and do by these Letters of Registration grant unto the said Robert Henry Firth, his executors, administrators, and assigns, the exclusive enjoyment and advantage of the said invention or improvement, for and during the term of fourteen years from the date hereof ; to have, hold, and exercise unto the said Robert Henry Firth, his executors, administrators, and assigns, the exclusive enjoyment and advantage thereof, for and during and unto the full end and term of fourteen years from the date of these presents next and immediately ensuing, and fully to be complete and ended : Provided always, that if the said Robert Henry Firth shall not, within three days after the granting of these Letters of Registration, register the same in the proper office in the Supreme Court, at Sydney, in the said Colony of New South Wales, then these Letters of Registration, and all advantages whatsoever hereby granted, shall cease and become void.

In witness whereof, I have hereunto set my sign manual, and have caused the present Letters of Registration to be sealed with the seal of the said Colony of New South Wales, at Government House, Sydney, in New South Wales, this sixteenth day of April, in the year of our Lord one thousand eight hundred and eighty-four.

[L.S.]

AUGUSTUS LOFTUS.

Improvements in Arresting Sparks from Steam-engines.

SPECIFICATION of ROBERT HENRY FIRTH, of Tenandra, Martaguy Creek, in the Colony of New South Wales, engineer, for an invention entitled "Improvements in Apparatus for Arresting Sparks from Steam-engines."

My invention relates to that class of steam engines and boilers which have a "smoke-box," and more especially to boilers of locomotive and portable engines. It has been devised for the purpose of arresting the sparks, cinders, &c., heretofore carried up the chimney, and depositing them in the smoke-box or other receptacle without practically interfering with the draught.

It consists essentially in interposing a perforated screen between the boiler flues and its chimney or funnel in such a way as to allow of the passage of the smoke and other gaseous products of combustion through said screen direct to the chimney or funnel, and at the same time to arrest the solid products and carry them up a long vertical flue in which there is a gradually decreasing draught so as to finally allow them to fall of their own accord into the smoke-box or other receptacle provided for them.

Referring to my drawings, where the same letters indicate similar parts wherever they appear. Figure 1 is a longitudinal sectional elevation of a locomotive boiler constructed according to my invention with a divided enlargement of the smoke-box. Figure 2 is an end elevation partly in section of the same, and figure 3 a plan of figure 2.

A is the shell of the boiler, A¹ the tubes, B the smoke-box, B¹ the smoke-box door, B² the funnel or chimney, and C the cylinder exhaust pipe, which parts are well understood; D is a cylindrical extension of the smoke-box, and E an upward extension or "smoke-case"; D¹ is horizontal portion of the screen or partition springing from the tube plate just above the highest tubes A¹; and D² is the vertical portion extending to nearly the top of case E; F is a hinged flap or perforated plate wire work or such like.

In operation the products of combustion passing through the tubes A¹ enter the smoke-box B, beneath the screen D¹, and after a portion or most of the smoke passes through such screen and up the chimney or funnel the remainder carrying the solid matters is drawn through or under flap F, and with a gradually diminishing draught up the outside, through and over the top of the screen D² into the chimney or funnel as shown by the full arrows. The gradually diminishing draught allows the solid matters (sparks, cinders, &c.) to fall to the bottom of the extension D, from whence they are cleared out whenever desired.

Figure 4 is part of a similar view to figure 1, the only difference being that figure 1 shows how I prefer to construct a new boiler, while the other figure represents how I propose to add my improvements to an existing boiler.

Figure 5 is a sectional elevation of an alternative arrangement, wherein, instead of the smoke-box being enlarged, the divided enlargement is constructed around the funnel or chimney, but the action is the same as those before described.

I prefer that the upward extension (such as that marked E) should reach nearly as high as the chimney, and that its breadth should be about equal to the diameter of the chimney, or wider if necessary; also that the dividing screen should be of woven wire of say one-eighth of an inch gauge, and that the hinged flap (which I sometimes dispense with altogether) should be of punched plate or wire work of say one-quarter to three-eighths of an inch gauge.

Having thus particularly described and ascertained the nature of my said invention, and the manner in which it is to be performed, I would have it understood that what I believe to be new, and therefore claim as my improvements in apparatus for arresting sparks from steam-engines is:—

First—Interposing a perforated screen between the flue of the boiler and its funnel or chimney in such a way as to compel the solid matters that are too large to pass through said screen to travel along a vertical flue with a constantly diminishing draught, so as to allow them to fall of their own accord into the smoke-box or other receptacle for the purpose, substantially as herein described and explained.

Second—The special methods of arranging such screen as herein described and as illustrated in my drawings.

In witness whereof, I, the said Robert Henry Firth, have hereto set my hand and seal, this twenty-ninth day of January, one thousand eight hundred and eighty-four.

Witness—

ROBERT H. FIRTH.

ADOLPH ALEXANDER, J.P.

EDWD. WATERS, Agent for Applicant, Sydney.

This is the specification referred to in the annexed Letters of Registration granted to Robert Henry Firth, this sixteenth day of April, A.D. 1884.

AUGUSTUS LOFTUS.

REPORT.

Sir,

Sydney, 25 February, 1884.

We do ourselves the honor to report, in reply to your blank cover of the 31st January, No. 84, that we are of opinion that the prayer of Mr. R.H. Firth, for Letters of Registration of an invention entitled "Improvements in Apparatus for Arresting Sparks from Steam-engines" may be granted in terms of his specification and drawing.

We have, &c.

E. O. MORIARTY.
JOHN WHITTON.

The Under Secretary of Justice.

R. H. FIRTH'S PATENT

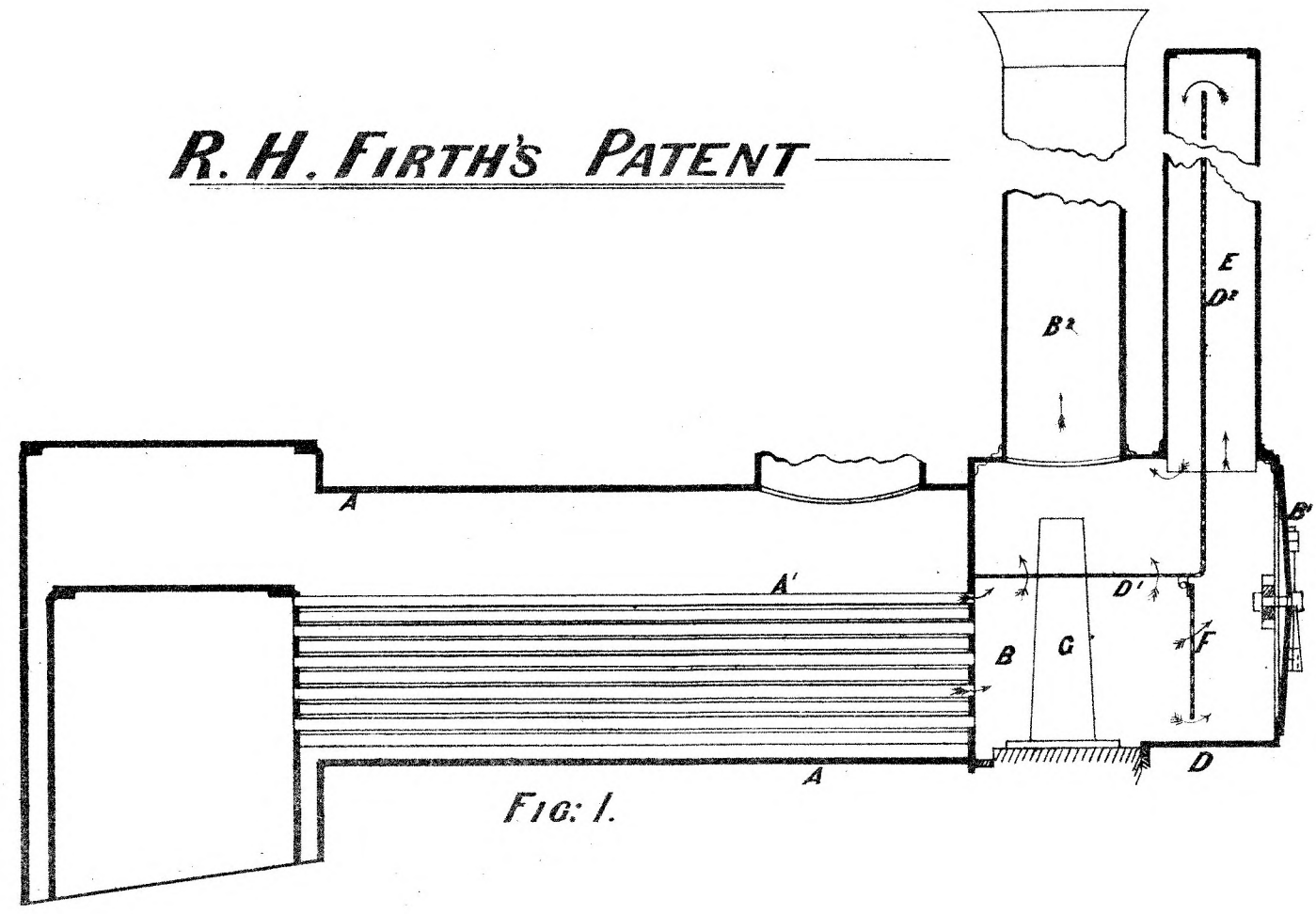


FIG. 1.

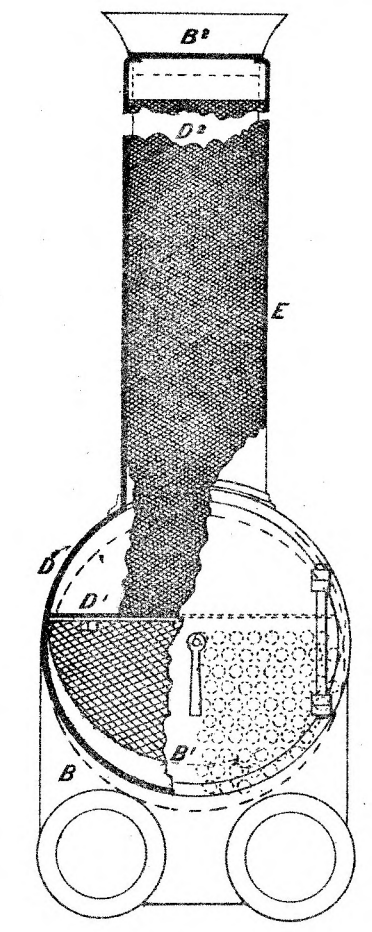


FIG. 2.

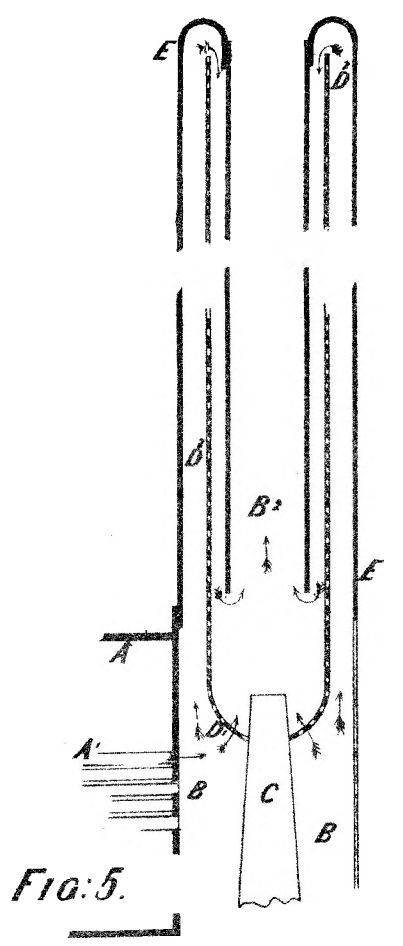


FIG. 5.

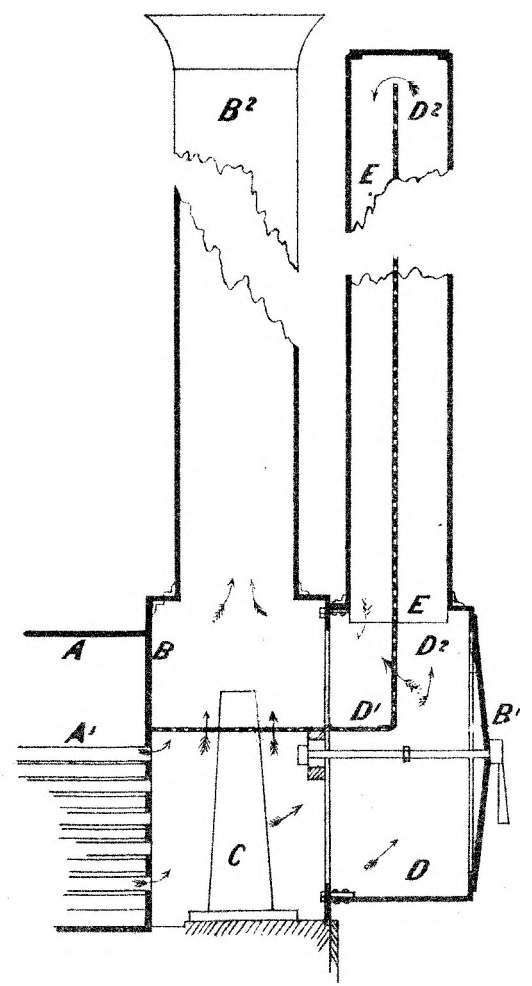


FIG. 4.

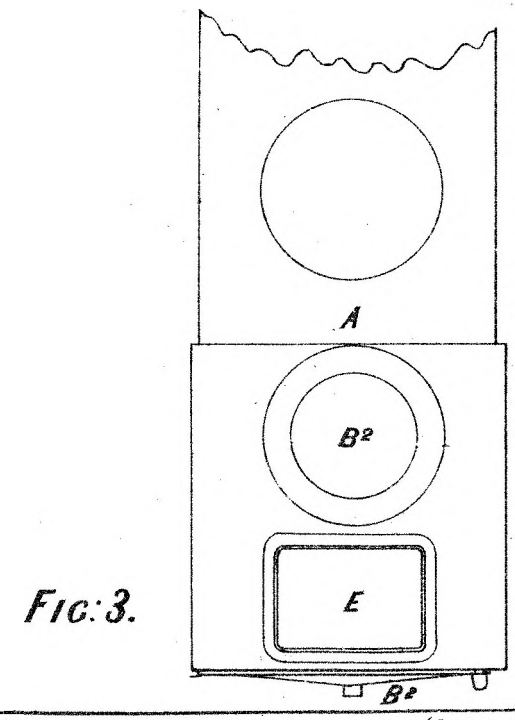


FIG. 3.

This is the Sheet of Drawings referred to in the annexed Letters of Registration granted to Robert Henry Firth, this sixteenth day of April, A.D. 1884.

Augustus Loftus

PHOTO-LITHOGRAPHED AT THE GOVT. PRINTING OFFICE, SYDNEY, NEW SOUTH WALES.

(Sig 245-)



A.D. 1884, 17th April. No. 1407.

IMPROVEMENTS IN MATERIAL AND APPARATUS FOR ENRICHING
ILLUMINATING GAS.

LETTERS OF REGISTRATION to William Hooker, for Improvements in
Materials and in Apparatus for enriching Illuminating Gas.

[Registered on the 18th day of April, 1884, in pursuance of the Act 16 Vic. No. 24.]

BY HIS EXCELLENCY THE RIGHT HONORABLE SIR AUGUSTUS WILLIAM FREDERICK SPENCER LOFTUS
(commonly called LORD AUGUSTUS LOFTUS), Knight Grand Cross of the Most Honorable Order of
the Bath, a Member of Her Majesty's Most Honorable Privy Council, Governor and Commander-in-
Chief of the Colony of New South Wales and its Dependencies.

TO ALL TO WHOM THESE PRESENTS SHALL COME, greeting :

WHEREAS WILLIAM HOOKER, of Station-street, Newtown, Sydney, in the Colony of New South
Wales, hath by his Petition humbly represented to me that he is the author or designer of a certain
invention or improvement in manufactures, that is to say, of an invention entitled "Improvements in
Material and in Apparatus for enriching Illuminating Gas," which is more particularly described in the
specification and the sheet of drawings which are hereunto annexed ; and that he, the said Petitioner, hath
deposited with the Honorable the Treasurer of the said Colony of New South Wales the sum of Twenty
Pounds sterling, for defraying the expense of granting these Letters of Registration, as required by the
Act of Council, sixteenth Victoria, number twenty-four ; and hath humbly prayed that I would be pleased
to grant Letters of Registration, whereby the exclusive enjoyment and advantage of the said invention or
improvement might be secured to him for a period of fourteen years : And I, being willing to give
encouragement to all inventions and improvements in the arts or manufactures which may be for the
public good, and having received a report favourable to the prayer of the said Petition, from competent
persons appointed by me to examine and consider the matters stated therein and to report thereon for
my information, am pleased, with the advice of the Executive Council, and in exercise of the power and
authority given to me by the said Act of Council, to grant, and do by these Letters of Registration grant
unto the said William Hooker, his executors, administrators, and assigns, the exclusive enjoyment and
advantage of the said invention or improvement, for and during the term of fourteen years from the date
hereof ; to have, hold, and exercise unto the said William Hooker, his executors, administrators, and
assigns, the exclusive enjoyment and advantage thereof, for and during and unto the full end and term of
fourteen years from the date of these presents next and immediately ensuing, and fully to be complete
and ended : Provided always, that if the said William Hooker shall not, within three days after the
granting of these Letters of Registration, register the same in the proper office in the Supreme Court, at
Sydney, in the said Colony of New South Wales, then these Letters of Registration, and all advantages
whatsoever hereby granted, shall cease and become void

In witness whereof, I have hereunto set my sign manual, and have caused the present Letters of
Registration to be sealed with the seal of the said Colony of New South Wales, at Govern-
ment House, Sydney, in New South Wales, this seventeenth day of April, in the year of
our Lord one thousand eight hundred and eighty-four.

[L.S.]

AUGUSTUS LOFTUS.

Improvements in Material and in Apparatus for enriching Illuminating Gas.

TO ALL TO WHOM THESE PRESENTS SHALL COME: I, WILLIAM HOOKER, of Station-street, Newtown, Sydney, in the Colony of New South Wales, send greeting:

WHEREAS I am the author and inventor of improvements in material and in apparatus for enriching illuminating gas, and am desirous of obtaining Letters Patent securing to me Her Majesty's Special License that I, my executors, administrators, or assigns, or such others as I, my executors, administrators, or assigns, may at any time agree with, and no others, may use, exercise, or vend in the Colony of New South Wales, during the term of fourteen years succeeding the date at which this instrument is left at the office of the Colonial Secretary, Sydney; and whereas, in order to obtain the said Letters Patent, it is necessary that I particularly ascertain and describe the nature of my invention and the manner in which its operations are performed:

Now, know ye, that I, William Hooker, do hereby declare the nature of my invention, and the manner in which its operations are performed in the following description, reference being made in the drawing plan herewith, and the letters and figures thereon indicating the parts referred to and here explained.

It is well known that ordinary coal and other illuminating gas can be enriched by the vapour of other hydro-carbons, and that it is desirable to heat such gas especially before its enrichment.

Now, my invention consists, first, in the use of a certain combination of materials which will produce a vapour that will enrich coal gas to its maximum extent, and, at the same time, prevent its supersaturation from excessive heat, which only makes the gas smoky; and, secondly, it consists in a peculiar construction of apparatus for admitting the heating and expansion of the unenriched gas, and for delivering it in such a position as best to ensure its enrichment.

My combination of materials consists of naphtha, naphthaline, paraffine, and camphor, preferably in the following proportions, viz.:—16 ounces of naphthaline, 4 ounces of solid paraffine, and 2 ounces of camphor.

I first dissolve the camphor in so much naphtha as is necessary for the purpose, and then mix this solution with the naphthaline and the paraffine until it forms a homogeneous mixture. With this mixture I half fill my improved apparatus, which consists of a hollow chamber, preferably in the shape of a sphere, the upper half of which, or nearly the upper half of which, has an inner lining, so as to form a semi-spherical chamber, through which the unenriched gas passes, and is discharged at the bottom, through a series of perforations, on to the surface of my mixture. This apparatus I place in such a position as to be heated either by the gas jets which my apparatus supplies, or by a special jet provided for the purpose.

In my drawings figure 1 shows one form of gas pendant with my apparatus A attached, and figure 2 section on the line II; in the figure 1 C is the surface of my mixture; A¹ is the semi-spherical chamber; b the supply pipe to my apparatus; B the supply pipe from my apparatus to the burners C; D are the holes for the gas at the bottom of semi-spherical chamber A¹; a is plug-hole for supplying my mixture to chamber A.

Figure 2 shows a similar apparatus to that illustrated in figure 1, except that the spherical chamber is placed below the level of the burners it supplies, and so is heated by a jet F specially provided for the purpose. It also differs inasmuch as it is not a perfect sphere, but has a flat bottom at H; G is the small supply pipe for jet F, which is regulated by knob K.

Figure 3 shows my apparatus in a different position, viz., over a reflector M; in this case it is heated by the hot current of air passing upward through a hole in the centre of the reflector.

Figure 4 shows my apparatus attached to a bracket lamp, and figure 5 section on the line pp in figure 4. The peculiarity in this case is that the discharge holes at the bottom of the semi-spherical chamber are only at one side instead of all round, and at that side which is furthest from the entrance to the supply pipe R, and also furthest from the entrance of the gas into my semi-spherical chamber.

Figure 5 shows a similar apparatus to that illustrated in that of figure 2, except that the burners hang downwards from spherical chamber, therefore doing away with jet F, as shown on figure 2.

In each case, and in many others which might be shown, if desirable, but which will readily suggest themselves to those skilled in the art to which this invention relates, my apparatus might be placed, the requirement being that it must be placed between the unenriched gas supply pipe and the burners which consume the enriched gas, and it must be heated.

Having thus described the nature of my invention and the manner of performing same, I would have it understood that I do not claim to be the inventor of the process of enriching gas by heating it and passing it through or in contact with some carburetted material, as I know that to be old; neither do I confine myself to any particular shape of chamber for my apparatus, although I believe the spherical shape, which I have shown, to be the best. What I believe to be new, and therefore claim, is:—

First—The combination of naphtha, naphthaline, paraffine, and camphor, preferably, but not only in the manner and proportions herein set forth as a mixture for the enrichment of coal and other illuminating gas, in the manner substantially as herein described and explained.

Second—The use of a hollow chamber, preferably spherical or approximately spherical, for the reception of the enriching mixture, the upper part of which chamber has an inner lining, so as to form a large spreading area for the gas to expand, and with holes at the bottom for it to discharge immediately over the surface of the enriching mixture, substantially as herein described and explained.

In witness whereof I hereto put my hand and seal.

Witness—
W. J. SLACK.

WILLIAM HOOKER.

This is the specification referred to in the annexed Letters of Registration granted to William Hooker, this 17th day of April, A.D. 1884.

AUGUSTUS LOFTUS.

REPORT.

Improvements in Material and in Apparatus for enriching Illuminating Gas.

REPORT.

Sir,

Sydney, 18 February, 1884.

In the matter of the application of Mr. William Hooker for Letters of Registration for "Improvements in material and in apparatus for enriching Illuminating Gas," which has been referred to us, we have examined the specification and drawings accompanying the same, and have now the honor to report that we see no objection to the issue of Letters of Registration, as prayed for.

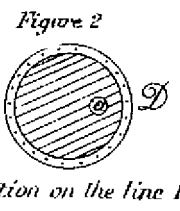
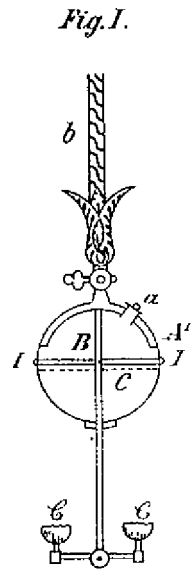
We have, &c.,

J. SMITH.

JAMES BARNET.

The Under Secretary of Justice.

[Drawings--one sheet.]



Section on the line II

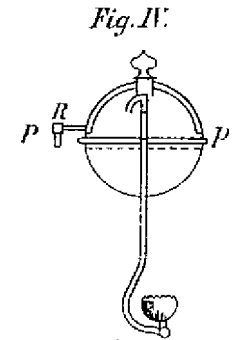
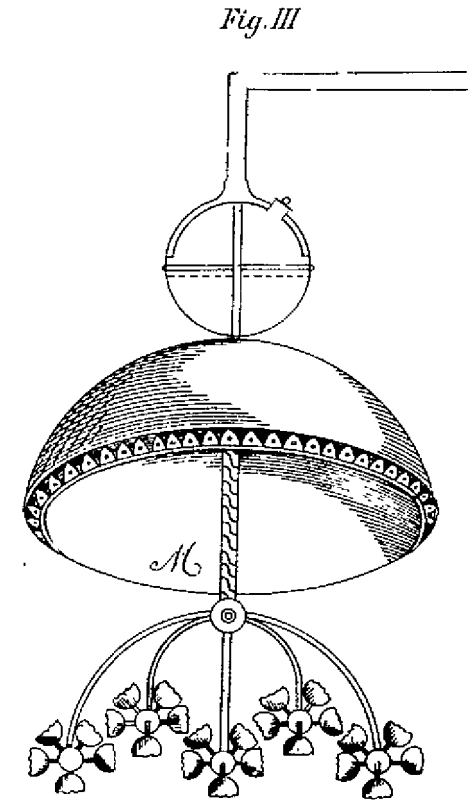
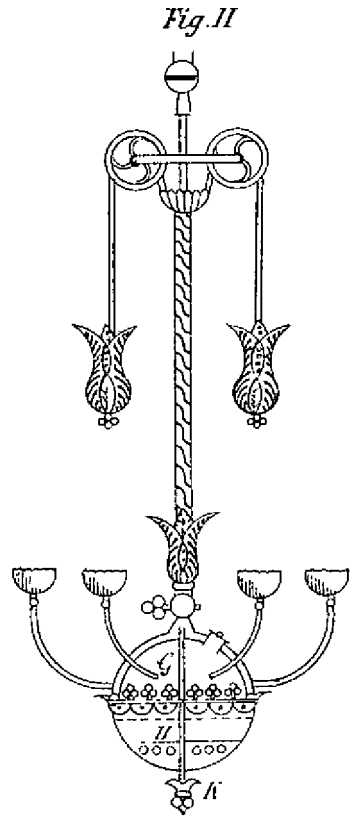
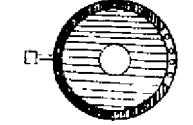
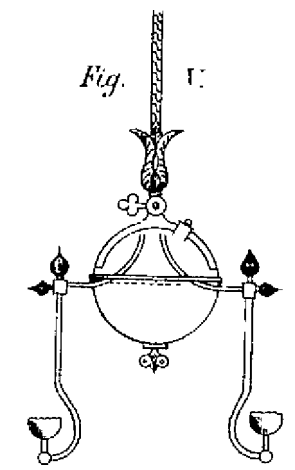


Figure 5



Section on the line pp.



This is the sheet of Drawings referred to in the annexed Letters of Registration granted to William Hooker, this seventeenth day of April, A.D., 1884.

Augustus Loftus.

This is the Plan referred to in my Specification herewith

Wm. Hooker



A.D. 1884, 16th April. No. 1408.

IMPROVEMENTS IN CLEARING THE GROOVES OF TRAM-RAILS.

LETTERS OF REGISTRATION to Joseph Husband, for Improvements in apparatus for removing earth and other obstructions from within the grooves of tram-rails.

[Registered on the 18th day of April, 1884, in pursuance of the Act 16 Vic. No. 24]

BY HIS EXCELLENCY THE RIGHT HONORABLE SIR AUGUSTUS WILLIAM FREDERICK SPENCER LOFTUS (commonly called LORD AUGUSTUS LOFTUS), Knight Grand Cross of the Most Honorable Order of the Bath, a Member of Her Majesty's Most Honorable Privy Council, Governor and Commander-in-Chief of the Colony of New South Wales and its Dependencies.

TO ALL TO WHOM THESE PRESENTS SHALL COME, greeting:

WHEREAS JOSEPH HUSBAND, of Waverley, in the Colony of New South Wales, works overseer, hath by his Petition humbly represented to me that he is the author or designer of a certain invention or improvement in manufactures, that is to say, of an invention entitled "Improvements in apparatus for removing earth and other obstructions from within the grooves of tram-rails," which is more particularly described in the specification and the sheet of drawings which are hereunto annexed; and that he, the said Petitioner, hath deposited with the Honorable the Treasurer of the said Colony of New South Wales the sum of Twenty Pounds sterling, for defraying the expense of granting these Letters of Registration, as required by the Act of Council, sixteenth Victoria, number twenty-four; and hath humbly prayed that I would be pleased to grant Letters of Registration, whereby the exclusive enjoyment and advantage of the said invention or improvement might be secured to him for a period of fourteen years: And I, being willing to give encouragement to all inventions and improvements in the arts or manufactures which may be for the public good, and having received a report favourable to the prayer of the said Petition, from competent persons appointed by me to examine and consider the matters stated therein and to report thereon for my information, am pleased, with the advice of the Executive Council, and in exercise of the power and authority given to me by the said Act of Council, to grant, and do by these Letters of Registration grant unto the said Joseph Husband, his executors, administrators, and assigns, the exclusive enjoyment and advantage of the said invention or improvement, for and during the term of fourteen years from the date hereof; to have, hold, and exercise unto the said Joseph Husband, his executors, administrators, and assigns, the exclusive enjoyment and advantage thereof, for and during and unto the full end and term of fourteen years from the date of these presents next and immediately ensuing, and fully to be complete and ended: Provided always, that if the said Joseph Husband shall not, within three days after the granting of these Letters of Registration, register the same in the proper office in the Supreme Court, at Sydney, in the said Colony of New South Wales, then these Letters of Registration, and all advantages whatsoever hereby granted, shall cease and become void.

In witness whereof, I have hereunto set my sign manual, and have caused the present Letters of Registration to be sealed with the seal of the said Colony of New South Wales, at Government House, Sydney, in New South Wales, this sixteenth day of April, in the year of our Lord one thousand eight hundred and eighty-four.

[L.S.]

AUGUSTUS LOFTUS.

Improvements in Clearing the Grooves of Tram-rails.

SPECIFICATION of JOSEPH HUSBAND, of Waverley, in the Colony of New South Wales, works overseer, for an invention entitled "Improvements in apparatus for removing earth and other obstructions from within the grooves of tram-rails."

From the effects of vehicular traffic, the running away of rain-water, and other causes, the grooves of tram-rails laid along the public roadway quickly fill with dust and mud or other obstruction, which, if it were allowed to accumulate, would very soon bury or cover the rails, and it has heretofore been necessary to constantly employ a large number of men removing such dust, earth, &c.; now, my invention has been devised in order to do away with the large expense thus entailed, and has been so designed that the earth, &c., will be removed from within the tram-rail grooves before each tram passes over the line.

My improvements in apparatus for removing earth and other obstructions from within the grooves of tram-rails consist essentially in the combination and arrangement with or in front of an engine or carriage of a circular brush or disc, part of which preferably fits within the tram-rail groove, revolved by gear from the axle of said engine or carriage when it is travelling upon the said rails.

But in order that my invention may be clearly understood, I will now describe the same, with reference to the drawing hereto attached, in which figs. 1 and 2 are respectively skeleton elevation and plan of a tram motor, with my improved rail-cleaner attached, while figs. 3 to 10 are details of the same, hereinafter more particularly referred to.

A A (see figs. 3 and 4) are circular brushes, whose outer part A¹ fits within the tram-rail groove. A² is shaft carried in bearings A³ (figs. 5 and 6) at end of side frames B, whose inner ends are bearings B¹ (figs. 7 and 8) to fit on axle of tram motor or carriage. A⁴ A⁴ are adjustable collars and A⁵ chain pulley. C is a light casing fixed to shaft A² and frame B enclosing the brush, and having an opening C¹ at the back clear of the rails (see figs. 1 and 2). D is an adjustable cross-stay, connecting the side frames B by being bolted to them through one or other holes D¹, and to which is secured in one or other holes D² the upright rod D³, which has a screw-thread passing through nut D⁴, fixed to any convenient part of the floor or platform of engine or car, and terminates in hand-wheel D⁵. E is a split-pulley or pulley in halves for bolting to wheel-axle; and E¹ is a chain or cord passing over it and over pulley A⁵.

As the engine or carriage advances the pulley E, by means of chain E¹ and pulley A⁵, revolves the brushes A fixed on ends of shaft A². By means of hand-wheel D⁵ on screw-rod D³ the driver or attendant lowers or raises said brushes and casings C to or from the rail, and, when lowered, the portion A¹ fits within the groove, and by its revolution clears said rail and throws the dust, earth, &c., out backwards, the casing guiding it through opening C¹, where it is deposited upon the roadway clear of the rails.

Although I have shown and described the apparatus which I prefer to use in carrying out my invention, I would have it understood that I do not confine myself to any particular kind of brush or disc, casing, frames, bearings, driving or raising and lowering gear, or other details, so long as the nature of my said invention be retained, and that I do not claim the exclusive use of revolving brushes or discs for the purpose of removing earth and other obstructions from tram-rail grooves; but what I claim as my improvements in apparatus for removing earth and other obstructions from within the grooves of tram-rails is—

First—The combination and arrangement with or in front of an engine or carriage of a circular brush or disc, revolved upon or within the tram-rail by gear from the wheel-axle, substantially as herein described and explained.

Second—The combination and arrangement of parts, as illustrated in figs 3 to 10, and parts marked D, D¹, D², D³, D⁴, and E¹ (with or without the casing C), with the wheel-axle of a tram engine or carriage, substantially as herein described and explained, and as illustrated in the drawings.

In witness whereof, I, the said Joseph Husband, have hereto set my hand and seal, this first day of February, one thousand eight hundred and eighty-four.

EDWD. WATERS,
Agent for Applicant, Sydney.

JOSEPH HUSBAND,
(By his Agent, FRED. WALSH).

This is the specification referred to in the annexed Letters of Registration granted to Joseph Husband, this 16th day of April, A.D. 1884.

AUGUSTUS LOFTUS.

REPORT.

Sir,

In reference to your B.C. of 2nd instant, 84-1,397, forwarding for our report a Petition from Mr. Joseph Husband, of Waverley, New South Wales, for Letters of Registration for an invention entitled "Improvements in apparatus for removing earth and other obstructions from within the grooves of tram-rails," we have the honor to recommend, after having examined the specification and plans accompanying the Petition, that Letters of Registration should be issued to the Petitioner for the invention referred to.

The Under Secretary of Justice.

Sydney, 21 February, 1884.

We have, &c.,

JOHN WHITTON.
E. O. MORIARTY.

JOSEPH HUSBAND'S PATENT.

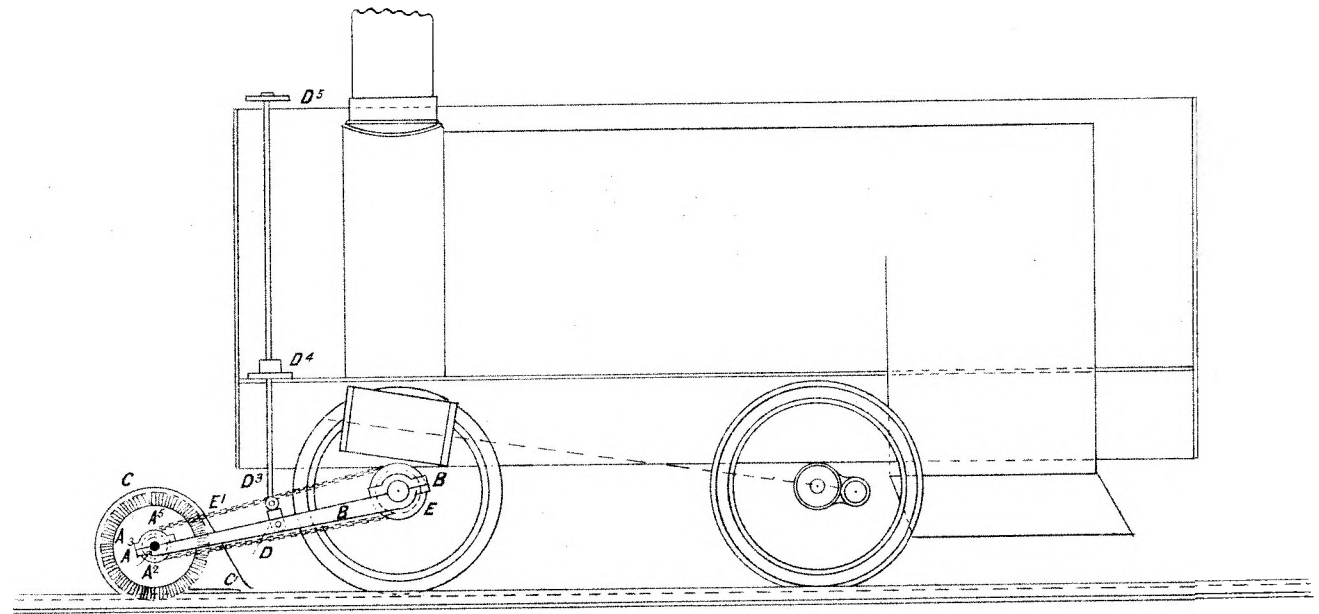


Fig. 1.

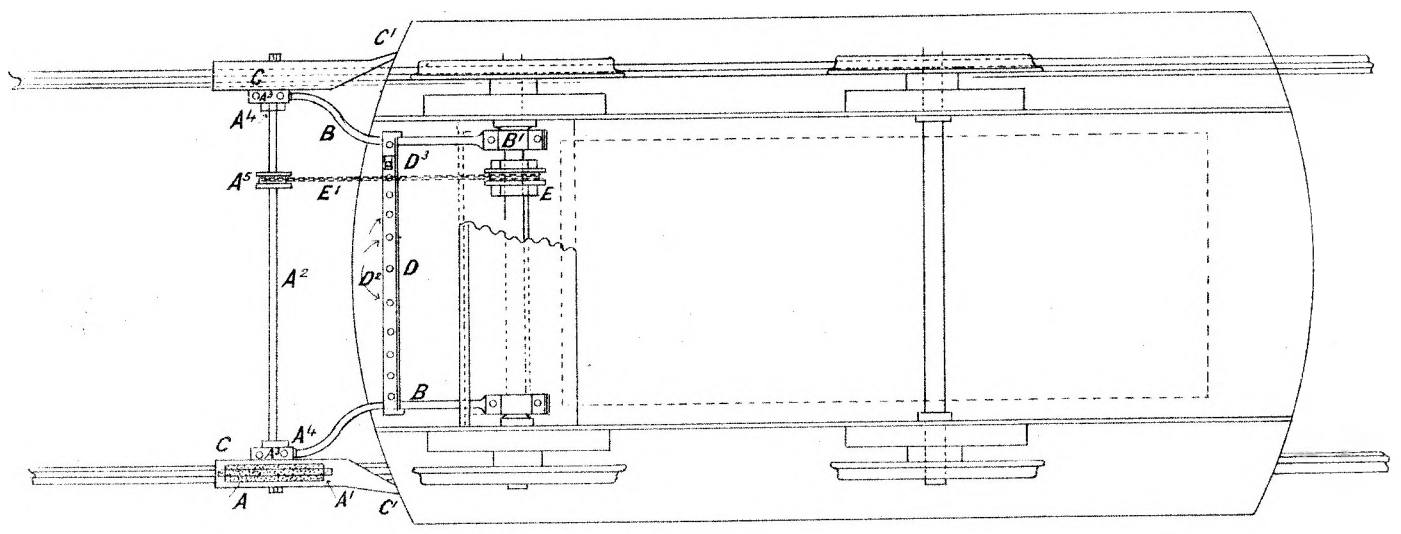


Fig. 2.

This is the sheet of Drawings referred to in the annexed Letters of Registration granted to Joseph Husband, this sixteenth day of April, A. D., 1884.
Augustus Loftus.

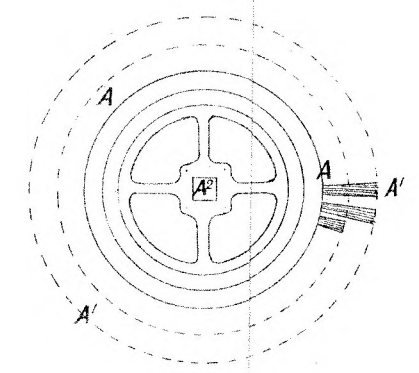


Fig. 5.

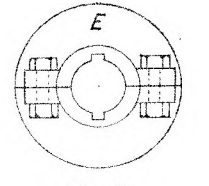


Fig. 9.

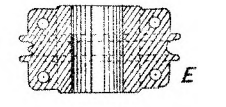


Fig. 10.

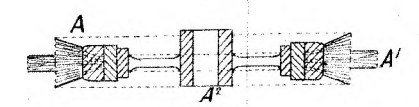


Fig. 4.

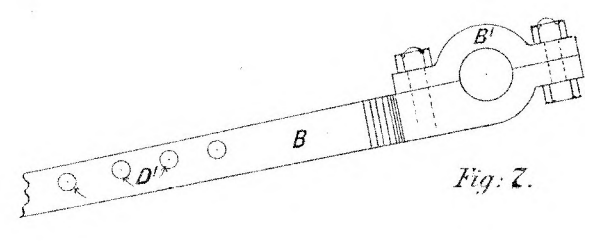


Fig. 7.

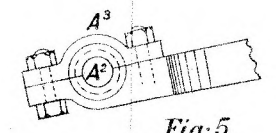


Fig. 5.

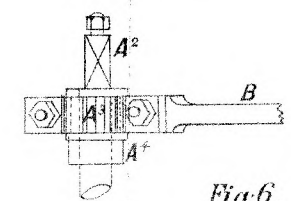


Fig. 6.

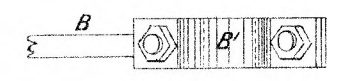


Fig. 8.



A.D. 1884, 16th April. No. 1409.

IMPROVEMENTS IN ROTARY ENGINES.

LETTERS OF REGISTRATION to Richard Pickup Park, for Improvements in Rotary Engines.

[Registered on the 18th day of April, 1884, in pursuance of the Act 16 Vic. No. 24.]

By HIS EXCELLENCY THE RIGHT HONORABLE SIR AUGUSTUS WILLIAM FREDERICK SPENCER LOFTUS (commonly called LORD AUGUSTUS LOFTUS), Knight Grand Cross of the Most Honorable Order of the Bath, a Member of Her Majesty's Most Honorable Privy Council, Governor and Commander-in-Chief of the Colony of New South Wales and its Dependencies.

TO ALL TO WHOM THESE PRESENTS SHALL COME, greeting :

WHEREAS RICHARD PICKUP PARK, of Normanby Road, South Melbourne, in the Colony of Victoria, engineer, hath by his Petition humbly represented to me that he is the author or designer of a certain invention or improvement in manufactures, that is to say, of an invention entitled "Improvements in Rotary Engines," which is more particularly described in the specification and the sheet of drawings which are hereunto annexed ; and that he, the said Petitioner, hath deposited with the Honorable the Treasurer of the said Colony of New South Wales the sum of Twenty Pounds sterling, for defraying the expense of granting these Letters of Registration, as required by the Act of Council, sixteenth Victoria, number twenty-four ; and hath humbly prayed that I would be pleased to grant Letters of Registration, whereby the exclusive enjoyment and advantage of the said invention or improvement might be secured to him for a period of fourteen years : And I, being willing to give encouragement to all inventions and improvements in the arts or manufactures which may be for the public good, and having received a report favourable to the prayer of the said Petition, from competent persons appointed by me to examine and consider the matters stated therein and to report thereon for my information, am pleased, with the advice of the Executive Council, and in exercise of the power and authority given to me by the said Act of Council, to grant, and do by these Letters of Registration grant unto the said Richard Pickup Park, his executors, administrators, and assigns, the exclusive enjoyment and advantage of the said invention or improvement, for and during the term of fourteen years from the date hereof ; to have, hold, and exercise unto the said Richard Pickup Park, his executors, administrators, and assigns, the exclusive enjoyment and advantage thereof, for and during and unto the full end and term of fourteen years from the date of these presents next and immediately ensuing, and fully to be complete and ended : Provided always, that if the said Richard Pickup Park shall not, within three days after the granting of these Letters of Registration, register the same in the proper office in the Supreme Court, at Sydney, in the said Colony of New South Wales, then these Letters of Registration, and all advantages whatsoever hereby granted, shall cease and become void.

In witness whereof, I have hereunto set my sign manual, and have caused the present Letters of Registration to be sealed with the seal of the said Colony of New South Wales, at Government House, Sydney, in New South Wales, this sixteenth day of April, in the year of our Lord, one thousand eight hundred and eighty-four.

[L.S.]

AUGUSTUS LOFTUS.

Improvements in Rotary Engines.

SPECIFICATION of RICHARD PICKUP PARK, of Normanby Road, South Melbourne, in the Colony of Victoria, engineer, for an invention entitled "Improvements in Rotary Engines."

My invention of improvements in rotary engines has been designed for the following purposes:—First, for providing a means whereby the steam in rotary engine cylinders may be worked expansively by the introduction of a rotary cut-off valve having an adjustable port or steam supply opening therein, and fitted on the engine shaft and working in a suitable valve chest. This valve also carries a governor for regulating the speed of the engine when used single acting (or working only one way); secondly, in providing an arm piston made curved on the one side and flat on the other, and having its edgewise wearing surfaces packed with metallic strips, which are held up by small spiral springs fitted into said arm piston; thirdly, in providing a divisional ring, which is sprung into the grooves provided in covers or ends of cylinder to form a perfectly steam-tight joint. This ring is fitted with metallic packing rings on its outer periphery near both its ends. The gap edge of this divisional ring at the back of the arm piston has a transverse groove formed in it, which is fitted in with a metallic strip seated on small spiral springs; the front gap edge is fitted with a small steel friction roller attached thereto, and which travels on the curved face of said arm piston. It will be obvious that when this divisional ring is used in a reversing rotary engine it would require to have the metallic strip and springs on both sides of the gap, so as to ensure a perfect steam-tight joint. Fourth, in providing at the bottom of the cylinder a metallic joint piece or pad carefully fitted in a recess formed therein and seated on spiral springs as before, to ensure a good steam-tight joint between it and the before-mentioned divisional ring, thereby preventing the steam from passing from steam to exhaust side of same at this point. When it is required to use my improvements in an expansive reversing rotary engine, an additional ordinary slide valve, or a suitable cock, or some such mechanical means, is required to conduct the steam from one side of the piston to the other, as desired. My improvements may also be used in compound rotary engines by simply placing the cylinders side by side, and allowing the steam after being used in the high-pressed cylinder to pass into the low-pressed cylinder, as is already well known, or they may be separate and distinct cylinders placed on convenient beds, and the steam conducted from the high-pressure exhaust pipe to the low-pressure valve chest by suitable pipes; and I make the cylinders of such proportion to one another as to get the best results possible out of the steam used. When my invention is used for an atmospheric engine, the rotary valve and other parts similar to that used for steam purposes would be required. When used as a water engine, the rotary valve and valve chest would not be required. When used as a gas-engine, a special rotary valve, together with other attachments, is required, which I will hereinafter describe. When my rotary water-engine cylinder and piston is worked by some other motive power it makes a very serviceable suction or force pump.

Referring to the drawing, fig. 1 shows side elevation, fig. 2 plan with the cylinder shown in horizontal section and the valve piston removed, and fig. 3 end elevation with cylinder cover removed of my improved rotary engine. Fig. 4 is an end elevation of the cylinder cover with the steam-chest cover taken off. Fig. 5 is a vertical section of cylinder through line *aa*, fig. 4. Figs. 6 and 7 are longitudinal section and end view of the arm piston. Fig. 8 is an outside elevation of the divisional ring, and fig. 9 a cross-section on the line *bb* in fig. 8. Figs. 10, 11, 12, and 13 are four different views of the rotary cut-off valve. Fig. 14 is a vertical section of a cylinder for a reversing rotary engine, and fig. 14a is section of part of cover and part divisional ring, showing the section of compensating or wearing pieces. Fig. 15 is an end elevation of the cylinder cover with the valve-chest cover removed, and fig. 16 vertical section of said cylinder as designed for a gas-engine. Fig. 17 is a side view of the rotary gas-valve. Fig. 18 is an end and fig. 19 a side elevation of my rotary engine cylinder as constructed for a water engine or pump.

Figs. 1 to 13 represent the several views and details of a simple acting rotary engine designed for being worked expansively either by steam or air, and in which A represents the cylinder fitted on the jacket A¹, which is secured to the bed-plate A². This bed-plate also carries the two standards A³, in the bearings of which the engine shaft A⁴ works, and on which is keyed the pulley A⁵ and fly-wheel A⁶. On the back cylinder cover A⁷ is cast or formed the valve chest A⁸, which has a suitable cover A⁹. A¹⁰ is the steam or air supply branch, and B¹ the exhaust branch, the former leading into the valve chest, and the latter projecting from the cylinder cover A⁷, but leading from the exhaust passage at bottom of cylinder A similarly marked. The front cylinder cover A¹² is provided with a stuffing box A¹³ and gland A¹⁴, as is usual for steam joints. B and B¹ are the steam and exhaust passages formed in the bottom of the cylinder, and having the line of the portholes B² and B³ for communicating with the interior of said cylinder A. The steam passage B leads upwards through the back cylinder cover A⁷, and enters the valve chest A⁸, through the valve face B¹. The arm piston C, which is keyed on the engine shaft A⁴, is recessed or grooved on its end, and on both edges, and fitted with the metallic strips C¹, which are cushioned or seated on the spiral springs C², placed in the holes provided for them, thereby forming a perfect steam- or air-tight joint. It will be noticed that the back face C³ of this arm piston is made perfectly flat, and the front face C⁴ is curved as shown, so as to vary the opening or gap in the divisional ring D as little as possible when in work. The divisional ring D is sprung into, and revolves in the annular grooves D¹, cut or formed in the cylinder covers, and has metallic rings D² sunk in on its outer periphery near its ends, so as to prevent steam escaping through the before-mentioned annular grooves D¹. At the bottom of the cylinder this ring travels on the metallic strip or pad D³ let into the recess in the bottom of cylinder, and which rests on the spiral springs D⁴. The edge of this ring in the gap at the back of the arm piston has a groove formed in it, in which is fitted a metallic strip D⁵ forced forward by the small spiral springs D⁶. The front edge in said gap has a friction roller D⁷ working in bearings formed thereon. There are also four compensating or wearing pieces K fitted flush into cylinder covers inside said divisional ring D as shown. These pieces are made adjustable by being fixed in their recesses by the screw pins K¹ which pass through oblong slots provided in said wearing pieces K, so as to allow them to be set to fit the inner circumference of divisional ring D, and prevent undue pressure on outer circumference of same. The rotary adjustable cut-off valve E has key-ways E¹ cut in it which fit on the feathers or pins fixed to the engine shaft A⁴, which carry and revolve said valve. This valve has a part E², as shown, and a recess formed on its outer periphery in which is fitted the two portions of a metallic ring E³, which is divided.

Improvements in Rotary Engines.

divided diagonally, as shown in fig. 12, directly opposite to the port E³. The one half of this ring E³ is a fixture, and the other half is secured to the valve E by the countersunk headed bolts E¹ which pass through oblong holes in said valve, thereby providing a means for adjusting the length of the port E². E³ is the governor pivoted to the valve on the tap bolt E⁴ and controlled by the spiral spring E⁵. This valve is turned on its outer circumference to work on valve face B¹, and faced up at the back to work on the facing provided on front cylinder cover, thereby preventing the escape of steam from chest to cylinder.

Fig. 14 illustrates a vertical section of the cylinder of a reversing rotary engine in which the additional parts necessary to convert the before-described single acting into a reversing engine are shown, and which may be worked expansively by the before-described rotary cut-off valve. In this fig. similar letters indicate similar parts to those previously referred to, and in addition thereto F is a slide valve working on the valve face in the valve chest F¹, and connected to the hand lever F² by the valve spindle F³. G is the steam-supply branch and G¹ the upper exhaust port. G² and G³ are the annular passages leading from the ports in valve face to the passages B¹ and B at the bottom of the cylinder before referred to. The divisional ring D for a reversing engine requires to have both its edges abutting on the arm piston C fitted with the metallic strip D¹ and spiral springs D², so as to form a steam joint on either side of said arm piston.

Fig. 14^a shows section of part of cylinder cover and part of divisional ring D with the before referred to compensating or wearing strips K fitted in position.

Figs. 15, 16, and 17 illustrate the additions and alterations necessary for working my improved rotary engine by the explosion and consequent expansion of a given quantity of gas fed at regular intervals, or to speak more simply, for converting it into a gas-engine. For this purpose the port now marked H in the rotary valve E is somewhat different, as it has no side opening, it being now simply a recess or chamber, as shown. The valve face supply and exhaust passages are similar to those previously described. The gas-supply pipe H¹ and air pipe H² are fixed in the position shown. A gas jet or flame H³ is also placed as shown opposite the hole H⁴, which is controlled by a trigger or flame-regulating valve II¹ pivoted in a recess inside of the cylinder A. This is opened by means of the sliding pin II², which is forced forward at the desired position by means of the spring II³, which, together with said pin, is fitted in the end of the arm piston C.

The annular passage L formed around the cylinder is used in my gas-engine as a cold-water jacket, into which the water is fed through the inlet pipe L¹, and finds egress through the outlet pipe L², as shown. Alternative set-up or wearing pieces are shown in fig. 15, where there are four friction rollers L³ let into cylinder covers and fitted on to four slide pieces L⁴ fixed to said covers as before.

Figs. 18 and 19 illustrate elevations of my rotary cylinder A as altered for either a water-engine or a suction pump, the internal parts of cylinder being a *fac simile* of that previously described for a steam-engine. It will be noticed that the valve chest and ports leading therefrom, and consequently the rotary cut-off valve, have been dispensed with, and that the inlet and outlet ports B and B¹ in the bottom of cylinder simply project far enough from cover to allow them to be connected to the supply and discharge or the suction and delivery for either an engine or pump.

The mode of operation in a single-acting engine, that is, an engine working one way only as described with reference to figs. 1 to 13, is as follows:—Steam or air being supplied through the branch pipe A¹⁰ into valve chest A⁹, from whence the port E² in the rotary cut-off valve E is travelling over port B in the valve face B¹ steam or air is admitted through said passage B into the cylinder A and pushes forward the arm piston C until such time as the port E² in said rotary valve E has traversed over the port B in said valve face B¹, after which the blank face of the valve passes over same, which cuts off the steam or air supply to cylinder, and the steam or air expanding still forces round the piston C and its attached divisional ring D, until the piston C has passed over the exhaust port B¹, when the steam or air is free to escape, and the arm piston C moving forward to the required distance beyond the steam or air port B the steam or air is again admitted, and the foregoing operation repeated until the engine is stopped by closing the supply cock. The speed of the engine is regulated by the governor E⁵ attached to the rotary valve E.

The operation of the double-acting or reversing engine is similar to the foregoing so far as action of the rotary cut-off valve E and the steam on the piston is concerned, and so far as its being admitted in one port and exhausting through the other, but the conducting of the steam into the required passage leading to said ports B and B¹ is accomplished by the slide valve F operated by the hand lever F². The steam then being admitted through the passage on the one side, after doing its duty in the cylinder, finds exit through the opposite passage, and finally exhausts under the slide valve F into the atmosphere or otherwise. And in the case of a compound engine the exhaust steam either enters direct into the adjoining low-pressed cylinder or into the valve chest on said low-pressed cylinder.

The operation in a rotary gas-engine which is fitted with my special valve hereinbefore described is that the required quantity of gas and air are admitted through recess in chamber H in said rotary cut-off valve and through gas passage B into cylinder, and the piston rotating opens the trigger valve H³, which allows enough gas to escape through hole H⁴ to ignite the gas in said cylinder. This trigger valve II¹ is almost immediately closed by reason of the arm piston C quickly passing over it, thereby preventing the flame from being blown out by the explosion of contained gas. The consequent explosion and expansion of the contained gas then forces the piston C forward until the exhaust port B is reached, when the above mechanical movements will be again repeated. During the working of the gas-engine a current of cold water is caused to pass through the annular passage L around cylinder. If it were desired to make this gas-engine reversible a trigger valve H⁵ would be required on the other side of piston also, and the gas and air would have to be led from the rotary cut-off valve to the opposite port and side of piston, the gas being then ignited on that side only for the time being.

The operation in my rotary engine driven by water-power is as follows:—The rotary valve E, valve chest A⁹, and ducts or passages leading therefrom to parts in bottom of cylinder would not be necessary. The water would be simply admitted in the one port and its force exerted on that side of piston C until the exhaust or discharge port was reached, where the water would find sufficient area for exit, and so on. If the reverse motion was desired, the water would require to be fed on the opposite side, and so on, as is well known.

Improvements in Rotary Engines.

I also desire to state that my rotary engine as before described can be used as a rotary suction or force pump, that is by its arm piston C being on and consequently driven by one of my before-described rotary engines affixed to the same bed when the power would be direct acting, or the rotary pump may be driven by having a pulley fixed on its piston shaft, which is driven by a belt or pulley on some other power, or by spur gearing or otherwise. The operation would be that the inlet pipe to pump cylinder would be fixed to the port on the one side of said cylinder, and the discharge fitted to the port on the other side.

Having thus described the nature of my invention and the manner of performing same, I would have it understood that what I believe to be new, and therefore claim as my improvements in rotary engine, is :—

- First—The rotary adjustable cut-off or expansion valve E fitted on the engine shaft A⁴, and with or without a governor E⁵, substantially as herein described and explained, and as illustrated in my drawings.
- Second—The metallic arm piston C keyed on engine shaft A⁴ made flat on one side and curved on the other, and having its end and two edges grooved out to receive strips of metallic packing C¹ held up by small spiral springs C², substantially as herein described and explained, and as illustrated in my drawings.
- Third—The divisional ring D, whose edges abut on the before-described arm piston, and both of which edges have transverse grooves cut in them filled with metallic packing strips D³ held forward by spiral springs D⁴, as shown in fig. 14, or instead of both edges having such grooves and packing, one only may be so constructed and the other provided with a friction roller D⁷, as shown in fig. 9, substantially as herein described and explained, and as illustrated in my drawings.
- Fourth—The compensating or wearing pieces K fitted flush in the cylinder covers A⁷ and A¹² inside said divisional ring D, substantially as and for the purpose herein described and explained, and as illustrated in my drawings.
- Fifth—The joint piece or pad D³ fitted into the recess formed in the bottom of a rotary engine cylinder A, in the manner and for the purpose substantially as herein described and explained, and as illustrated in my drawings.
- Sixth—The combination of the special rotary cut-off chamber valve E, the trigger valve H⁵, operating pin H⁶, spring H⁷, gas and air supply pipes H¹ and H² with the cylinder having an outer jacket L through which a current of cold water flows, and the before-described arm C, piston and divisional ring D, for the purpose of producing a gas-engine, substantially as herein described and explained, and as illustrated in figs. 15, 16, 17 of the drawings.
- Seventh—The governor E⁵ attached by a tap bolt E⁶ to the rotary valve E, and controlled by a spiral spring E⁷, also affixed to valve and governor, all substantially as herein described and explained, and as illustrated in my drawings.

In witness whereof, I, the said Richard Pickup Park, have hereto set my hand and seal, this eleventh day of February, one thousand eight hundred and eighty-four.

RICHARD PICKUP PARK.

Witness—

EDWD. WATERS,
Melbourne, Patent Agent.

This is the specification referred to in the annexed Letters of Registration granted to Richard Pickup Park, this sixteenth day of April, A.D., 1884.

AUGUSTUS LOFTUS.

REPORT.

Sir,

We have carefully examined the specification and drawings accompanying the application for Letters of Registration from Mr. Richard Pickup Park, 84-2, 168, entitled "Improvements in Rotary Engines," and we recommend that the petition be granted.

We have, &c.,

E. C. CRACKNELL.
ARCH. FRASER.

The Under Secretary of Justice.

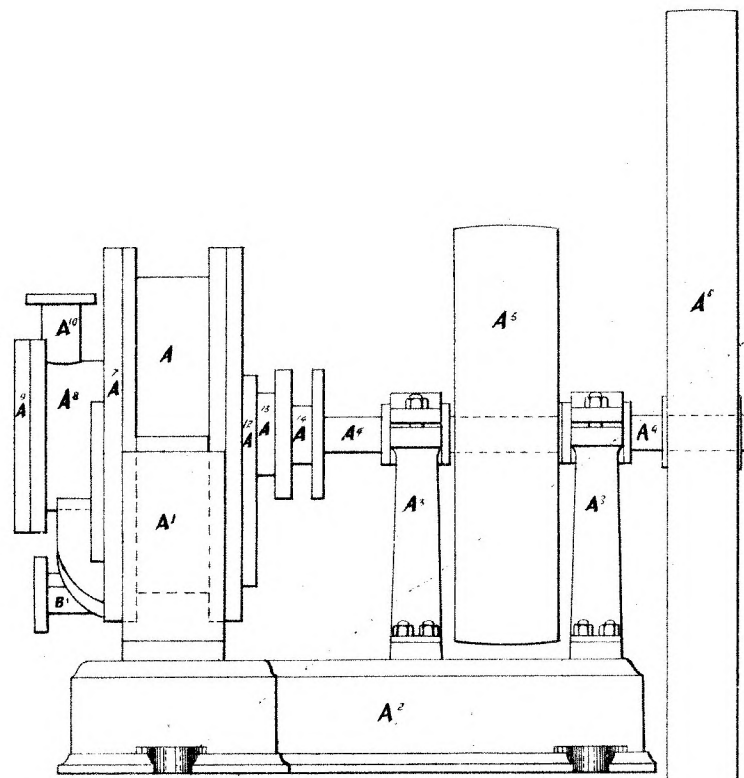


FIG. 1

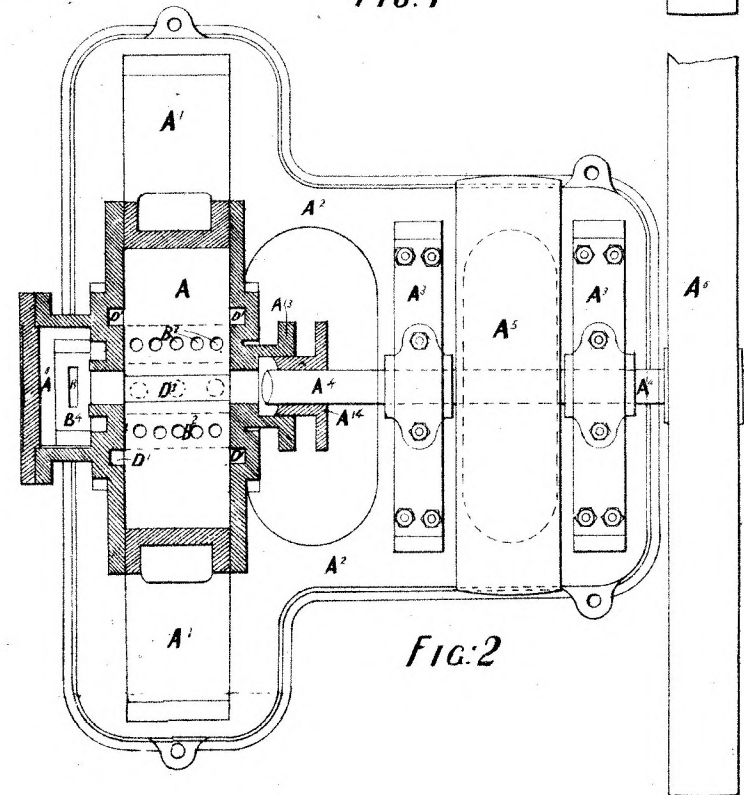


FIG. 2

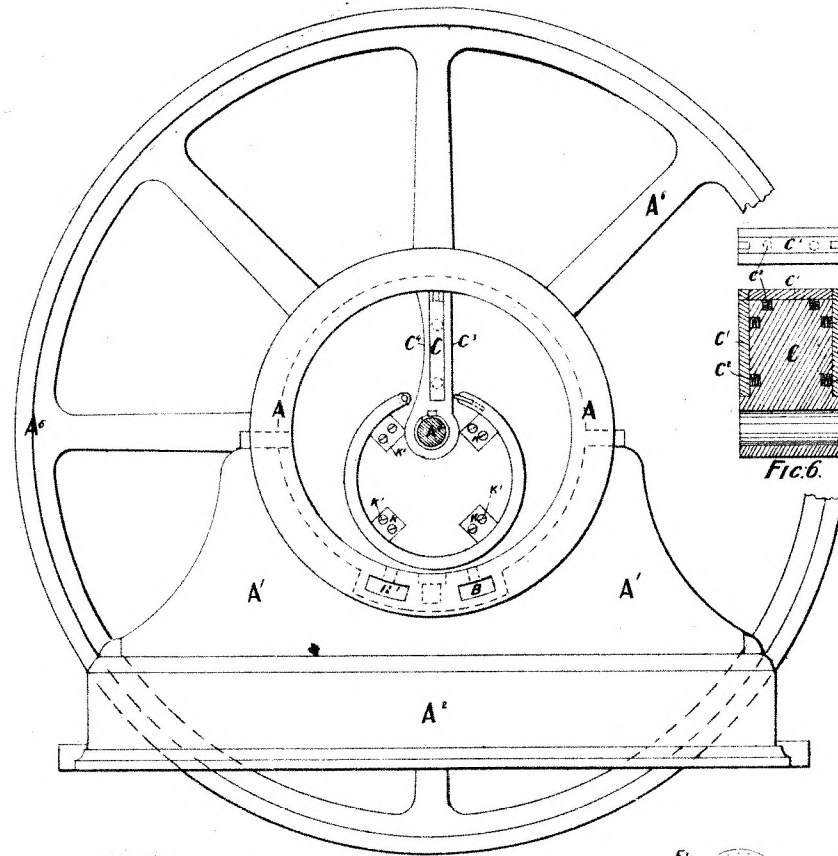


FIG. 3

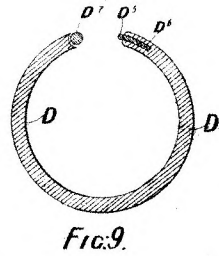


FIG. 9

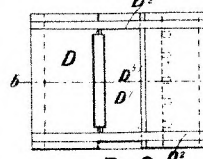


FIG. 8

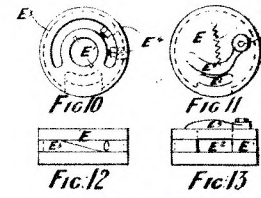


FIG. 10



FIG. 11



FIG. 12



FIG. 13

FIG. 17

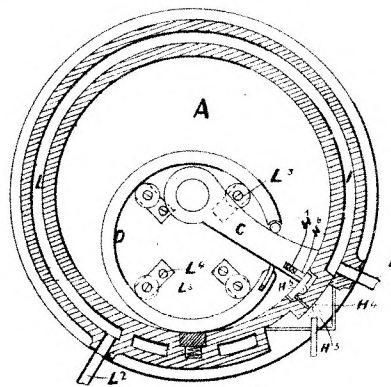


FIG. 6

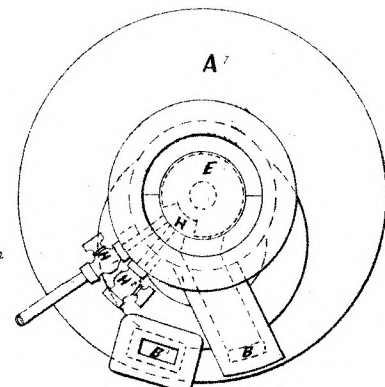


FIG. 15

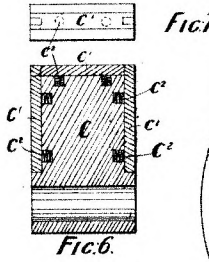


FIG. 6

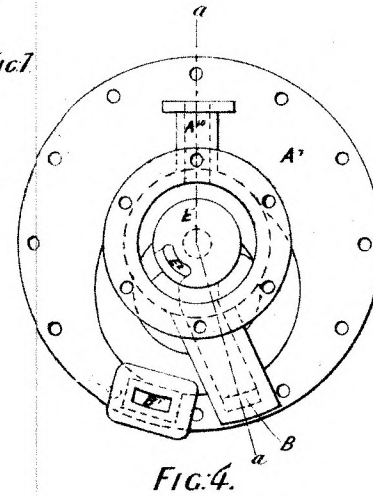


FIG. 4

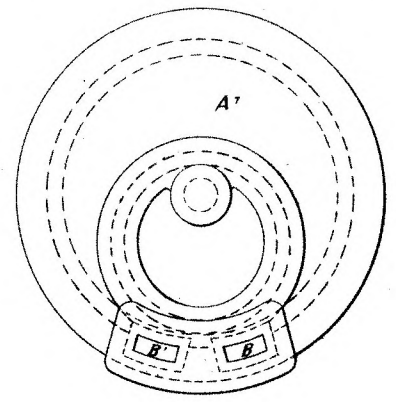


FIG. 18

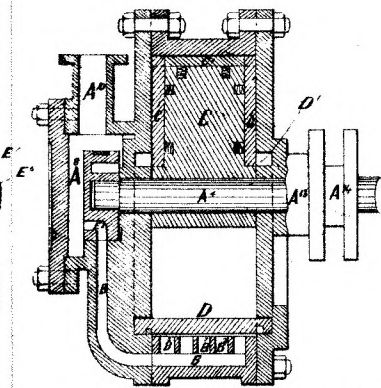


FIG. 5

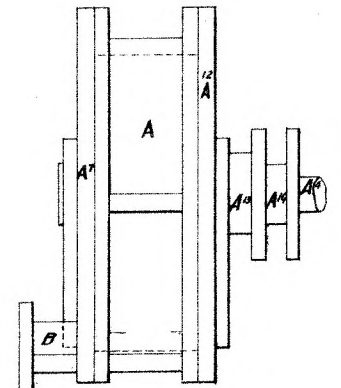


FIG. 19

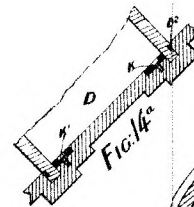


FIG. 14

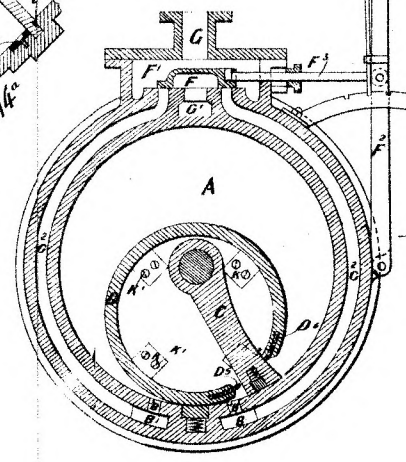


FIG. 14

R. P. PARK'S PATENT.

This is the Sheet of Drawings referred to in the annexed Letters of Registration granted to Richard Pickup Park, this sixteenth day of April, A.D. 1884.

Augustus Loftus.

PHOTO-LITHOGRAPHED AT THE GOVT. PRINTING OFFICE, SYDNEY, NEW SOUTH WALES.

(Sig 245-)



A.D. 1884, 16th April. No. 1410.

IMPROVEMENTS IN TELEPHONE EXCHANGE APPARATUS.

LETTERS OF REGISTRATION to William Henry Masters and Thomas Theophilus Draper, for Improvements in Telephone Exchange Apparatus.

[Registered on the 18th day of April, 1884, in pursuance of the Act 16 Vic. No. 24.]

BY HIS EXCELLENCY THE RIGHT HONORABLE SIR AUGUSTUS WILLIAM FREDERICK SPENCER LOFTUS (commonly called LORD AUGUSTUS LOFTUS), Knight Grand Cross of the Most Honorable Order of the Bath, a Member of Her Majesty's Most Honorable Privy Council, Governor and Commander-in-Chief of the Colony of New South Wales and its Dependencies.

TO ALL TO WHOM THESE PRESENTS SHALL COME, greeting :

WHEREAS WILLIAM HENRY MASTERS and THOMAS THEOPHILUS DRAPER, both of No. 55, Chancery-lane, Melbourne, in the Colony of Victoria, electricians, have, by their Petition, humbly represented to me that they are the authors or designers of a certain invention or improvement in manufactures, that is to say, of an invention entitled "Improvements in Telephone Exchange Apparatus," which is more particularly described in the specification and the sheet of drawings which are hereunto annexed ; and that they, the said Petitioners, have deposited with the Honorable the Treasurer of the said Colony of New South Wales the sum of Twenty Pounds sterling, for defraying the expense of granting these Letters of Registration, as required by the Act of Council, sixteenth Victoria, number twenty-four ; and have humbly prayed that I would be pleased to grant Letters of Registration, whereby the exclusive enjoyment and advantage of the said invention or improvement might be secured to them for a period of fourteen years : And I, being willing to give encouragement to all inventions and improvements in the arts or manufactures which may be for the public good, and having received a report favourable to the prayer of the said Petition, from competent persons appointed by me to examine and consider the matters stated therein and to report thereon for my information, am pleased, with the advice of the Executive Council, and in exercise of the power and authority given to me by the said Act of Council, to grant, and do by these Letters of Registration grant unto the said William Henry Masters and Thomas Theophilus Draper, their executors, administrators, and assigns, the exclusive enjoyment and advantage of the said invention or improvement, for and during the term of fourteen years from the date hereof ; to have, hold, and exercise unto the said William Henry Masters and Thomas Theophilus Draper, their executors, administrators, and assigns, the exclusive enjoyment and advantage thereof, for and during and unto the full end and term of fourteen years from the date of these presents next and immediately ensuing, and fully to be complete and ended : Provided always, that if the said William Henry Masters and Thomas Theophilus Draper shall not, within three days after the granting of these Letters of Registration, register the same in the proper office in the Supreme Court, at Sydney, in the said Colony of New South Wales, then these Letters of Registration, and all advantages whatsoever hereby granted, shall cease and become void.

In witness whereof, I have hereunto set my sign manual, and have caused the present Letters of Registration to be sealed with the seal of the said Colony of New South Wales, at Government House, Sydney, in New South Wales, this sixteenth day of April, in the year of our Lord one thousand eight hundred and eighty-four.

[L.S.]

AUGUSTUS LOFTUS.

Improvements in Telephone Exchange Apparatus.

SPECIFICATION of WILLIAM HENRY MASTERS and THOMAS THEOPHILUS DRAPER, both of No. 55, Chancery-lane, Melbourne, in the Colony of Victoria, electricians, for an invention entitled, "Improvements in Telephone Exchange Apparatus."

THIS invention is for the purpose of facilitating the working of telephone exchanges, and is intended to be termed the multiple switch-board system.

The two most important requisites for large telephone exchanges are speed and economy. These requisites we supply in a high degree by our multiple switch-board system, which we have elaborated from the fundamental idea of having each operator reach all the subscribers' lines in an exchange, with one motion for each line, and of having each operator do all the work involved in effecting the connecting and disconnecting of the subscribers on her switch-board with any of the subscribers to the exchange. An operator has a certain number of subscribers, whose calls she answers. When one of these subscribers calls for a connection with any other subscriber, the operator who takes the order makes the connection of the two lines instantly, and rings the bell of the subscriber wanted. She also disconnects the subscriber when receiving notice so to do. All this is done without the operator moving more than a step or two.

A switch-board on this multiple system is composed of—first, a certain number of spring-jacks, one for each line entering the exchange; second, a number of annunciator drops—200 we find most suitable for one board; third, a number of pairs of connecting cords, each with suitable keys and connections for the operator's telephone, the apparatus for ringing subscribers' bells, and the clearing-out drops. As many switch-boards are required in an exchange as there are times 200 subscribers. For instance, with 1,000 subscribers five switch-boards would be necessary.

Referring to our drawings, figures 1 and 1^a show the general construction of the switch-board, in which A A are the drops placed across the board below the spring-jacks, B the spring-jacks, C the clearing-out shutters, B¹ and B² the cords, B³ and B³ the plugs in connection with the cords, D the cam levers on the key-board, E the cords, and E¹ and E² the pulleys for raising cords B¹ when not in use.

In the general arrangement of the board, the annunciators are placed across the board below the spring-jack, with the operator's key-board below the annunciator, and the shelf for holding the cords and pulleys above the spring-jacks. This arrangement allows the placing of the boards together, end to end, thus enabling any operator at any board to make connection with the spring-jacks on her board to those on any adjacent board in cases where those spring-jacks are nearer than the corresponding ones on her own board. The spring-jacks are mounted on bases, each containing 100, and are placed across the board, space being left for new rows, as the growth of the exchange may demand. The shelf from which the cords are suspended is made movable, so that when new rows of spring-jacks are added the shelf may be raised out of the way. The spring-jacks used with these multiple boards differ from those ordinarily used in the spring and contact point against which the spring normally rests, being both insulated from the frame. Figures 2 and 2^a show the form of spring-jack used, *a* being the metal body of the jack, *a*¹ the flexible spring in contact with the insulated point *a*², *a*³ the metal connection with *a*², *a*⁴ the insulators, *a*⁵ the nuts, and *a*⁶ the washers for connecting the body of the jack. When a plug is inserted in the jack, figure 3, the spring *a*¹ is lifted from the insulated contact point *a*², breaking a connection therefrom, and establishing a new connection through the inserted plug, against which the spring now rests, and thence to the cord connecting with the plug.

Figure 4 in our drawings is a diagram of circuits, which shows three spring-jacks of a line placed respectively on three multiple switch-boards. The circuit through these three jacks and the annunciator is from the subscriber's line F, past the lightning arrester G, to the spring *a*¹ of the first jack 1; from the contact point *a*², upon which this spring rests, to the spring *a*¹ of the second jack 2; from the contact point *a*³, upon which the spring of the second jack rests, to the spring of the third jack 3; and from the contact point upon which this last spring rests the circuit is through the annunciator H, belonging to that line, and thence to the ground. As is evident, the annunciator may be placed at any of the three boards, but at whichever board it is placed its magnet must be included in the circuit, between the last spring-jack and the ground. The springs and contact points included in this circuit being, as above described, insulated from the frame of the jack by hard rubber, no connection exists between the line circuit and the frame of any jack during its normal condition—that is, when not in use. The frames of the three jacks are all connected together, but normally to nothing else, by wires I. The line circuit through the system, as shown in this diagram, is lettered F. The wire which serves to connect together the frames of the jacks is lettered I. The insertion of a plug B³ at one of the three jacks, as shown at the second jack on board 2, lifts the spring *a*¹ free from the contact point *a*², upon which it normally rests, thus disconnecting the annunciator H and the ground, and establishing connection between the line and the cord, connecting with the plug, as well as the cross connection between the wire I and the frame of the jack. The frames of all the jacks of the same number being connected together are consequently all crossed with the line. An operator at any other board may therefore determine the fact of a cross between the jack-frames and the line by touching the frame of the jack at the front of the board with the plug which she is about to insert into the jack to complete a connection.

The plug with its cord and the key-board system complete a circuit to the operator's telephone, and through a battery to the ground. These circuits are shown in the diagram of the key-board system represented in figure 5. The two cords of each pair, B¹ and B², are connected respectively to the levers J J¹ of the calling keys belonging to that pair of cords. The contact points against which these calling keys normally rest are connected together, a clearing-out annunciator being introduced into the connection. A connecting wire K is also run from this connection to the lever L of the listening key. The lever actuating it is provided with a cam or eccentric D; by means of which, when the lever is forward, the key will be held down against the contact point without the continued pressure of the operator's hand, and when thrown back the key will spring up, thus breaking the connection with the contact point. The circuit from the contact point is through the telephone receiver M, microphone N, and test battery O, to ground. The listening key, when pressed down (which is its normal condition), connects both cords to the telephone, microphone, test battery, and ground. Suppose a plug of either cord to be inserted into the spring-jack of the calling subscriber, instant communication is established between the operator and that subscriber upon the insertion of the plug, through a circuit consisting of the plug B³, its cord B¹, the calling

Improvements in Telephone Exchange Apparatus.

calling key J, to which that cord is connected, the contact point b , against which the calling key normally rests, the listening key L, the contact point b^1 , against which it is pressed, the transmitter telephone M, test battery O, and ground. The operator, upon learning what subscriber is wanted, touches the other plug B³ of the pair of cords to the frame of the spring-jack of the called subscriber, thus testing whether his line is busy, and if it is not busy inserts the plug into the jack, establishing communication between the two subscribers. The effect of touching the plug to the frame of the spring-jack as a test is to close the circuit of the test battery through the telephone, key system, and cord, to the frame of the jack, and thence by the established cross to the line, in case the line is busy. The click in the operator's telephone is an indication of the fact that the line is busy, and an absence of the click informs her that the line is free. This click is heard upon touching the frame of the jack only when a plug is inserted at some other jack of that line, the inserted plug producing the cross between all of the frames (they being connected together) and the line. When two subscribers are thus connected the operator's telephone is still on the third leg, and as soon as they are in conversation the lever of the listening key is thrown backwards. This releases the spring of the listening key, thus disconnecting the cords entirely from the operator's outfit, and leaving the clearing-out annunciator in the circuit of the connected subscribers. The calling of either subscriber is effected by pressing the calling key connecting with the plug inserted into the desired subscriber's jack. This key, when pressed, breaks the circuit from the clearing-out annunciator H and the operator's telephone, and closes it to a contact point b^2 b^3 leading to a generator and to ground. This arrangement prevents any dropping of the clearing-out annunciator when either subscriber is called. A pair of calling keys and a listening key is required for every pair of cords.

Figure 6 is simply a modification of the system illustrated in figure 5. B¹ and B³ are flexible cords, connected to plugs B² and B³, passing over pulleys E¹ and E², and connected to springs J and J¹. H is the clearing-out annunciator, one connection of which, b , terminates in an insulated point, against which the spring J rests when in its normal position, the other end being connected to the spring J¹. D is a cam-lever for depressing the springs J and J¹, thus placing them in contact with points b^3 and b^2 of the calling springs or keys L and L¹. b^1 and b^2 are insulated terminals, against which the springs or keys L and L¹ normally rest. M is the operator's telephone; N the receiver; O the test battery; b^4 and b^5 are insulated points in connection with the calling battery P. R and S are hard rubber blocks, used to insulate J from J¹. The operator, on receiving a call, forces down the lever D, and thus depresses the springs J and J¹ against the points b^2 and b^3 , at the same time breaking the circuit with the annunciator H at the point b . The operator then inserts the plug B² in the spring-jack of the subscriber calling, who is then placed in the circuit of the operator's telephone. The circuit being from subscriber's spring-jack to plug B², cord B¹, spring J, contact b^2 , key L, contact point b^1 , telephone M, receiver N, test battery O, contact b^4 , key L¹, contact b^3 , spring J¹, cord B³, and plug B³, to ground-plate Q, through the plug resting against the plate. The operator then inserts the plug B³ in the spring-jack of the subscriber wanted, and then presses the key of the spring L¹ against the contact point b^1 , thus throwing the current of the calling battery over the line of the subscriber wanted. He then raises the lever D, leaving them in direct communication with each other through the clearing-out shutter H, the operator's instrument being disengaged by the same operation. Should the subscriber wanted be engaged at another board, the operator, when he touches the face of the spring-jack in the operation of inserting the plug, will hear a clicking sound in his telephone. This is caused by the test battery 2 being placed in circuit through the frame of the spring-jack of the subscriber wanted, at the board he is already engaged, the circuit being from the subscriber calling through B¹, J, L, M, N, O, b^4 , L¹, b^3 , J¹, B³, and through the frame of the jack of the subscriber called at another board.

We prefer to use the method described in figure 6, it being a better and more convenient arrangement than that shown in figure 5.

The spring-jacks used with the multiple switch-board are constructed as shown in figures 2, 2^a, and 3. a is the frame of the spring-jack, which is constructed of brass, or other suitable metal; a^1 is a spring, and a^2 a metal connection, both of which are insulated from the frame of the jack by the hard rubber pieces. a^3 and a^4 are nuts for holding wires between the washers a^5 . When a plug is inserted in the jack the spring is lifted from the insulated contact point a^2 , breaking a connection therefrom, and a new connection is established to the tip of the inserted plug, in which the spring rests. A connection or cross is also established between the spring and the frame of the jack through the medium of the plug; this provides for the operator's test. Hitherto it has been found that considerable trouble has been caused by calling instruments placed in subscribers' offices, and the magnets call-bell, shown in figure 7, has been specially designed to overcome that trouble, although any other description of call-bell could be used.

Figure 7 is a generator, used for calling the subscribers, and is so arranged that it can be driven either by hand or power. T is the front board, removable at pleasure, to which all the working parts are attached; U are the fluid magnets; V the armature; W the spur-wheel; X the soft rubber pinion; Y are spring points for making contact when replacing the cover of the box.

Having thus described the nature of our invention, and the manner of performing the same, what we claim is—

- First—Constructing each operator's board with a spring-jack for every line, centering at the exchange, for the purpose herein described and explained.
- Second—Continuing each subscriber's line wire through each operator's board, the insulated contact point and spring of each spring-jack of that subscriber being included in the circuit.
- Third—Connecting the frames of all the spring-jacks of the same subscriber, but normally to nothing else, for the purpose described.
- Fourth—Spring-jacks so constructed as that the spring and the contact point, against which the spring normally rests, are both insulated from the frame of the jack.
- Fifth—Inserting a test battery in the circuit of the operator's telephone, substantially as described.

Sixth—

Improvements in Telephone Exchange Apparatus.

- Sixth—Placing to earth one of the plugs of each pair of cords, thus enabling the operator, by the insertion of the first plug to complete his connection with the subscriber calling, substantially as shown.
- Seventh—Holding down the operator's listening key when answering a call, and preferably by means of a cam lever, as shown in figures 5 and 6.
- Eighth—Connecting the operator's telephone, microphone, and test battery in a loop circuit, as described in figure 6.
- Ninth—Cutting out from the operator's circuit the clearing annunciator H, figure 6, while the operator's telephone and test battery are in use.
- Tenth—Constructing the magnets generator, as shown, with all the working parts attached to the front for easy removal.
- Eloventh—The screws F, with spring connections, for fastening the front of the box.
- Twelfth—The combination of a pinion X (on the amature) of soft rubber, and having broad teeth, with the metallic spur-wheel W, having narrow teeth (see figure 7).
- Thirteenth—The arrangement of the switch-board, with switches on each section, for all wires entering the exchange, and the arrangement of clearing-out shutters or cords on the shelf overhead.
- In witness whereof, we, the said William Henry Masters and Thomas Theophilus Draper, have hereto set our hands and seals, this twenty-third day of February, one thousand eight hundred and eighty-four.

W. H. MASTERS.
THOS. T. DRAPER.

—

This is the specification referred to in the annexed Letters of Registration granted to William Henry Masters and Thomas Theophilus Draper, this 16th day of April, A.D. 1884.

AUGUSTUS LOFTUS.

REPORT.

Sir,

We have examined the specification and drawings accompanying Messrs Masters and Draper's application S4-2,469, for Letters of Registration for "Improvements in Telephone Apparatus," and consider that the petition may be granted.

The Under Secretary of Justice.

Sydney, 29 February, 1884.

We, have, &c.,

E. C. CRACKNELL.
H. C. RUSSELL.

[Drawings—one sheet.]

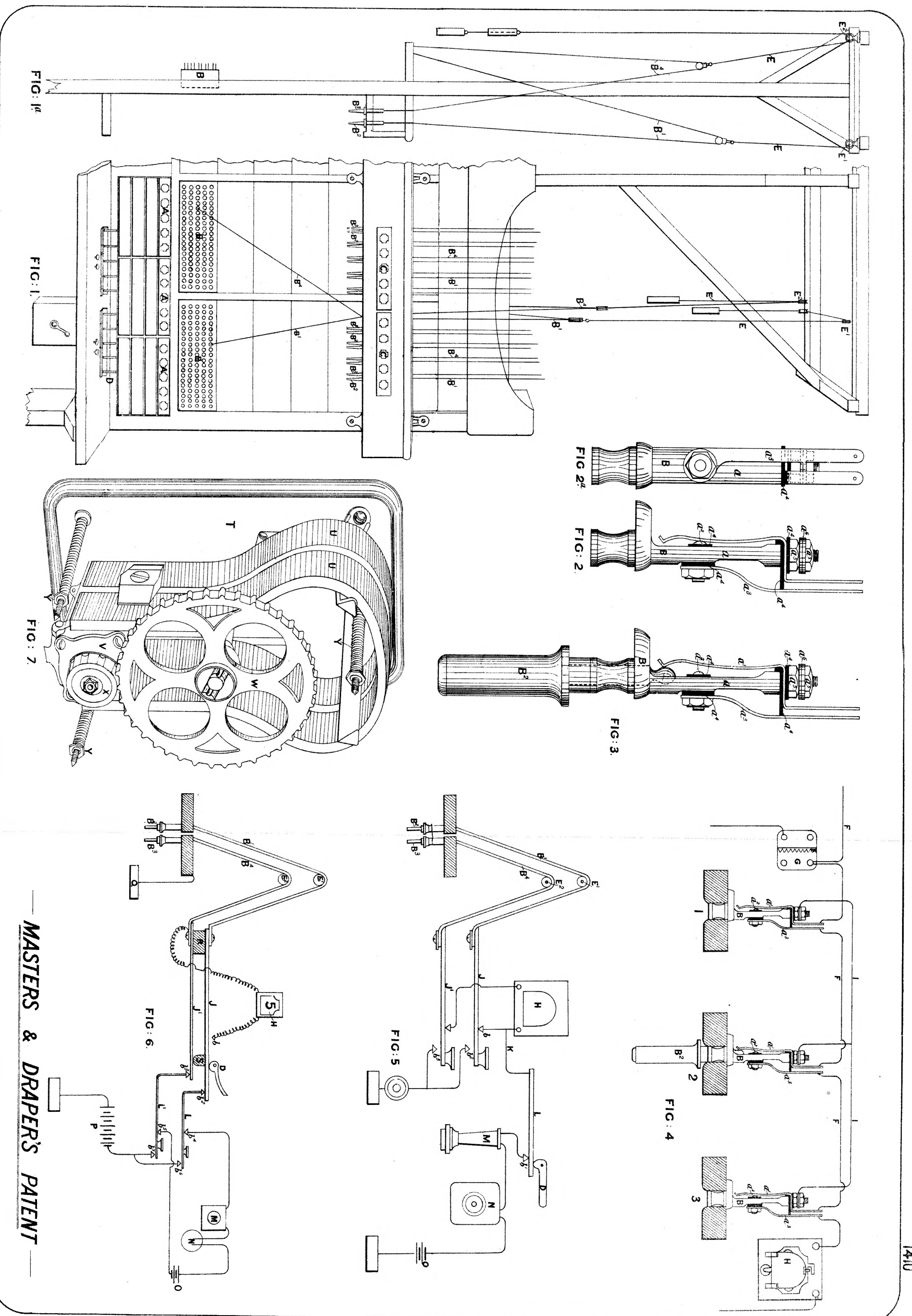


FIG. 1a

FIG. 1

FIG. 2

FIG. 2a

FIG. 3

FIG. 4

FIG. 5

FIG. 6

FIG. 7

—MASTERS & DRAPER'S PATENT—

*This is the Sheet of Drawings referred to in the annexed
 Letters of Registration, granted to William Henry Masters, and
 Thomas Theophilus Draper, this sixteenth day of April, A.D. 1884.
 Augustus Loftus.*

PHOTO-LITHOGRAPHED AT THE GOVT. PRINTING OFFICE,
 SYDNEY, NEW SOUTH WALES.

(Sig 245.)



A.D. 1884, 16th April. No. 1411.

IMPROVEMENTS IN WOOL-WASHING MACHINES.

LETTERS OF REGISTRATION to William Wilkinson, for Improvements in Wool-washing Machines.

[Registered on the 18th day of April, 1884, in pursuance of the Act 16 Vic. No. 24.]

BY HIS EXCELLENCY THE RIGHT HONORABLE SIR AUGUSTUS WILLIAM FREDERICK SPENCER LOFTUS (commonly called LORD AUGUSTUS LOFTUS), Knight Grand Cross of the Most Honorable Order of the Bath, a Member of Her Majesty's Most Honorable Privy Council, Governor and Commander-in-Chief of the Colony of New South Wales and its Dependencies.

TO ALL TO WHOM THESE PRESENTS SHALL COME, greeting :

WHEREAS WILLIAM WILKINSON, of Cathkin Cottage, Brunswick-street, North Fitzroy, in the Colony of Victoria, wool-sorter, hath by his Petition humbly represented to me that he is the author or designer of a certain invention or improvement in manufactures, that is to say, of an invention entitled "Improvements in Wool-washing Machines," which is more particularly described in the specification and the sheet of drawings which are hereunto annexed ; and that he, the said Petitioner, hath deposited with the Honorable the Treasurer of the said Colony of New South Wales the sum of Twenty Pounds sterling, for defraying the expense of granting these Letters of Registration, as required by the Act of Council, sixteenth Victoria, number twenty-four ; and hath humbly prayed that I would be pleased to grant Letters of Registration, whereby the exclusive enjoyment and advantage of the said invention or improvement might be secured to him for a period of fourteen years : And I, being willing to give encouragement to all inventions and improvements in the arts or manufactures which may be for the public good, and having received a report favourable to the prayer of the said Petition, from competent persons appointed by me to examine and consider the matters stated therein and to report thereon for my information, am pleased, with the advice of the Executive Council, and in exercise of the power and authority given to me by the said Act of Council, to grant, and do by these Letters of Registration grant unto the said William Wilkinson, his executors, administrators, and assigns, the exclusive enjoyment and advantage of the said invention or improvement, for and during the term of fourteen years from the date hereof ; to have, hold, and exercise unto the said William Wilkinson, his executors, administrators, and assigns, the exclusive enjoyment and advantage thereof, for and during and unto the full end and term of fourteen years from the date of these presents next and immediately ensuing, and fully to be complete and ended : Provided always, that if the said William Wilkinson shall not, within three days after the granting of these Letters of Registration, register the same in the proper office in the Supreme Court, at Sydney, in the said Colony of New South Wales, then these Letters of Registration, and all advantages whatsoever hereby granted, shall cease and become void.

In witness whereof, I have hereunto set my sign manual, and have caused the present Letters of Registration to be sealed with the seal of the said Colony of New South Wales, at Government House, Sydney, in New South Wales, this sixteenth day of April, in the year of our Lord one thousand eight hundred and eighty-four.

[L.S.]

AUGUSTUS LOFTUS.

Improvements in Wool-washing Machines.

SPECIFICATION of WILLIAM WILKINSON, of Cathkin Cottage, Brunswick-street, North Fitzroy, in the Colony of Victoria, wool-sorter, for an invention entitled "Improvements in Wool-washing Machines."

MY invention consists mainly in a novel mechanical arrangement for giving a peculiar motion to the tines or prongs used in dragging wool through the tanks of wool-washing machines. It also consists in the introduction of a shelf into the feeding end of such tanks.

The object of the peculiar motion given to the tines or prongs is, first, to descend into or on to and remove the waiting wool from a feeding shelf, which I prefer to make slotted or comb-shaped; second, to carry such wool a little below, and then longitudinally through the water; and, finally, to ascend up from the water without carrying any wool with them. To do this, I make my tines descend angularly to the back of the feeding-shelf, while from thence to the point of rising out of the water such tines are gradually assuming an upright position, and when they do so rise are perfectly upright or even slightly inclined backward.

Referring to my drawings, figs. 1 and 2 show, respectively, side and end views of my improved tines as applied to the tank of a wool-washing machine, while fig. 3 shows front and side views of one of the tines themselves; fig. 4 is a longitudinal section elevation of a wool-washing tank with my improvements fitted thereto, and fig. 5 is a plan of part of the feeding-shelf or grating F; fig. 6 shows side view of an alternative method of supporting the upper ends of said tines.

In all these figures the crank-shaft, marked A, is constructed with a series of three-throw cranks A¹, on which the clip-bearings B¹ of the tines B work and are supported. The upper portion B² of each tine constitutes a guide-rod, which passes through and works in the holes provided in the guide-bar C, which is secured at its ends to the brackets C¹, bolted to the tank D, as shown. Each crank-shaft A is supported in bearings A², secured to the top of the tank D, and derives its motion through the medium of the bevel gearing A³, from the line of shafting A⁴, as shown in fig. 2.

Fig. 6 shows an alternative method of supporting the upper end B² of the tines. In this case I form an eye B³ on said upper end, which is centred in another eye or fork formed on the end of the radius arms or levers B⁴, which are pivoted on the transverse shaft B⁵, supported in the standards B⁶, as shown.

In fig. 4 a delivery-fork K is shown. It is slightly dished at its lower end, and is worked by a single crank L, driven off the same line of shafting A⁴ as previously referred to.

The mode of operation is as follows (special reference being had to fig. 4):—In the first place, it will be obvious that when the tines B are being driven by the crank-shaft A, and the upper ends working in the guides C, that the travel of their extreme lower ends will describe a curvilinear line, as indicated by the dotted lines H in fig. 4. The wool to be washed is delivered from the cleansing rollers E on to the shelf or grating F, where it receives a shower or jet of clean water from a suitably perforated pipe G, and is then caught by the tines B, and drawn downward and forward through the water or liquid in the tank D, until it reaches the end of the stroke of said tines, where it receives a second shower or jet of water from the pipe G¹. The impetus given to the wool by the tines sends it forward until it comes within the range of the next series of lines, when it is again caught and carried along to a third shower or jet, and so on from one series of tines to the other, receiving a jet or shower of water between each until it reaches the end of the tank, where the wool is finally drawn along and under the water, and then lifted by the fork K on to the creper M, which delivers said wool into the next squeezing or cleaning rollers B⁷, or on to the table preparatory to drying or further treatment. N is a metal plate for directing the water jet on to the feeding shelf and prevent its being diverted by falling on the side of the lower roller E.

The operation of my alternative method, as shown in fig. 6, is similar to that already described with reference to figures 1 to 4; but it will be noticed that the extreme lower ends of the tines in their backward stroke make more of a curve, and in one full stroke describe an elliptical outline, as indicated by the dotted line H.

My feeding shelf may be plain, and not slotted, if so preferred, although I prefer them slotted or comb-shaped as shown.

Having thus described the nature of my invention, and the manner of performing same, I would have it understood that what I believe to be new, and therefore claim as my improvements in tank wool-washing machines, is—

First—The combination of a crank, preferably a three-throw crank, with elongated tines B, whose upper ends B² form guide-rods, and work in guide-bars C, substantially as herein described, and as illustrated in figs. 1 to 4 of my drawings.

Second—The construction of tank wool-washing machines with a feeding-shelf, preferably slotted or comb-shaped, substantially as and for the purposes herein described, and as illustrated in my drawings.

Third—The alternative method of supporting the upper ends B² of the tines B, by the radius levers B⁴, pivoted to a transverse shaft, substantially as herein described, and as illustrated in fig. 6 of my drawings.

In witness whereof, I, the said William Wilkinson, have hereto set my hand and seal, this fifteenth day of January, one thousand eight hundred and eighty-four.

Witness—

EDWD. WATERS,
Melbourne, Patent Agent.

W. WILKINSON.

This is the specification referred to in the annexed Letters of Registration granted to William Wilkinson, this sixteenth day of April, A.D. 1884.

AUGUSTUS LOFTUS.

W. WILKINSON'S PATENT

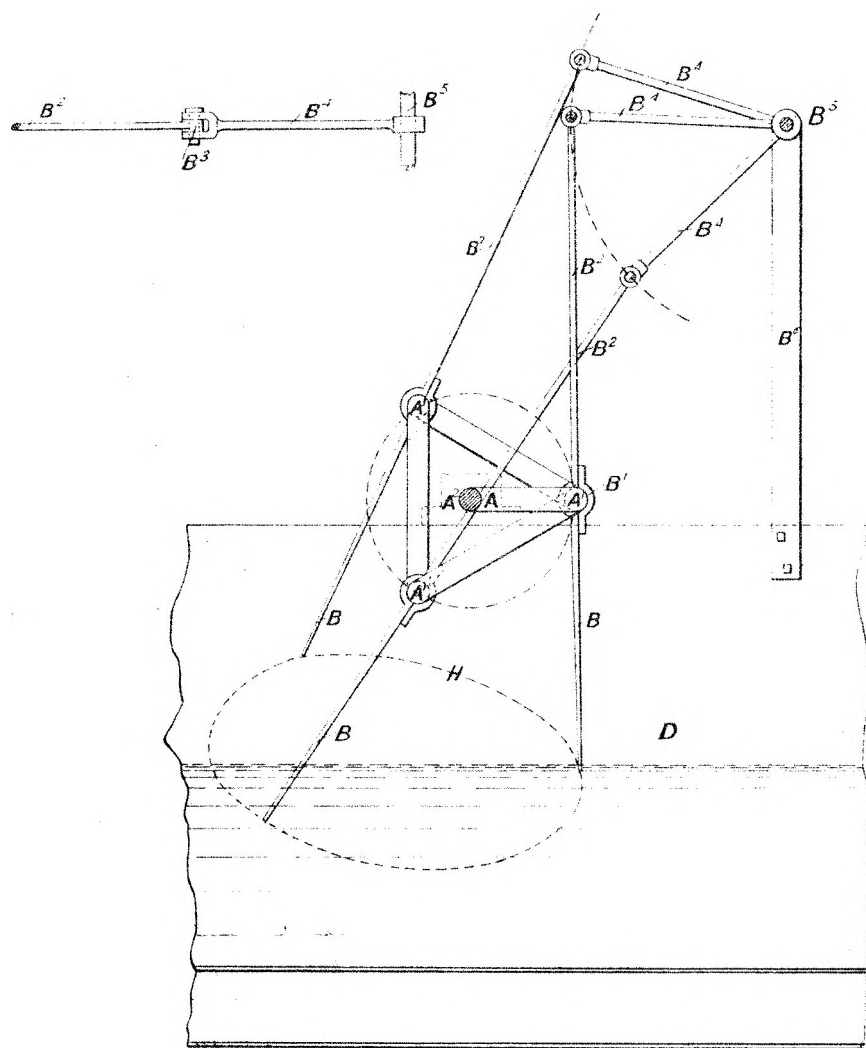


FIG: 6.

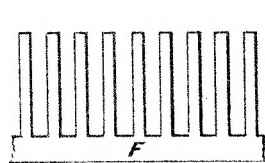


FIG: 5.

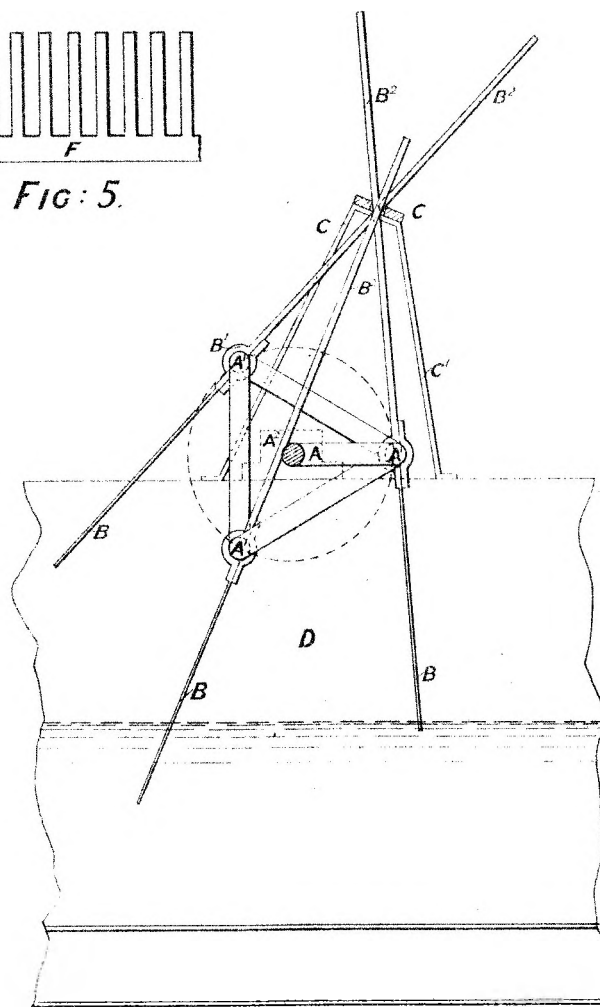


FIG: 1.

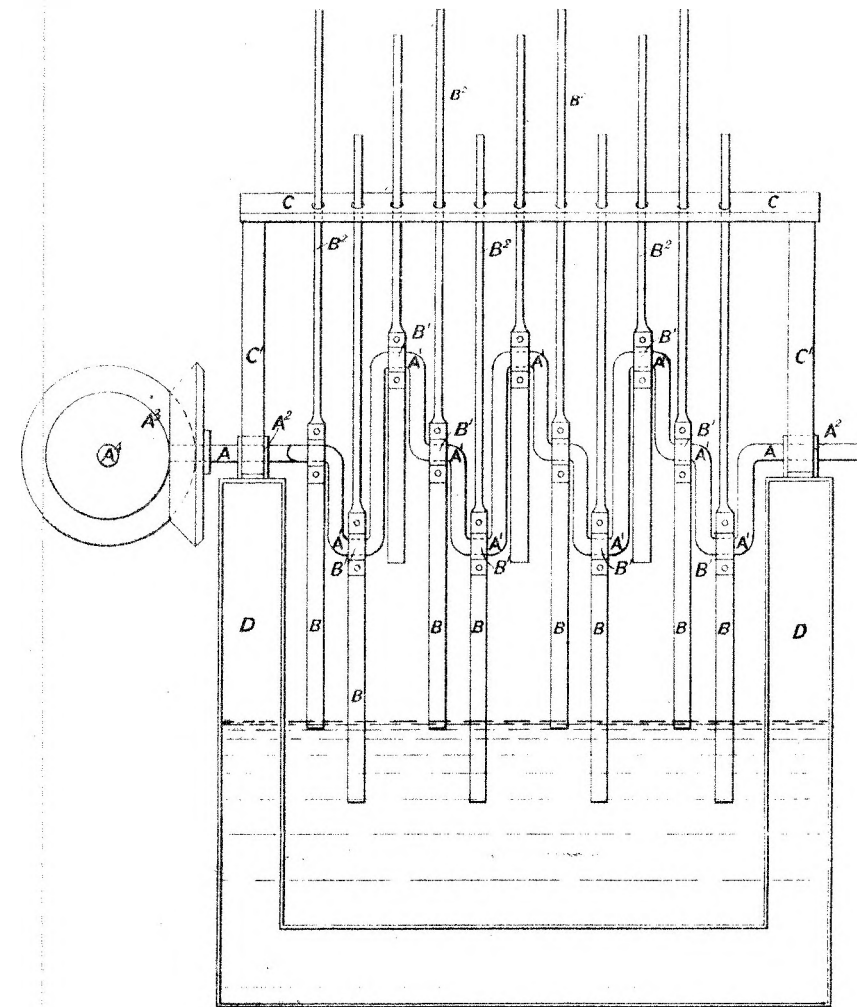


FIG: 2.

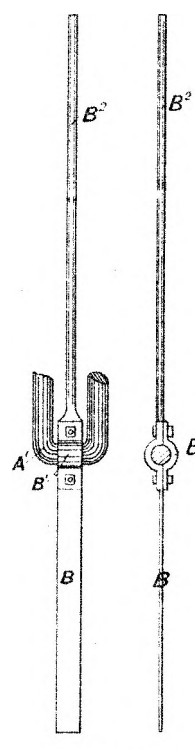


FIG: 3

This is the Sheet of Drawings referred to in the come ved Letters of Registration, granted to William Wilkinson, this sixteenth day of April, A.D., 1884.

Augustus Loftus.

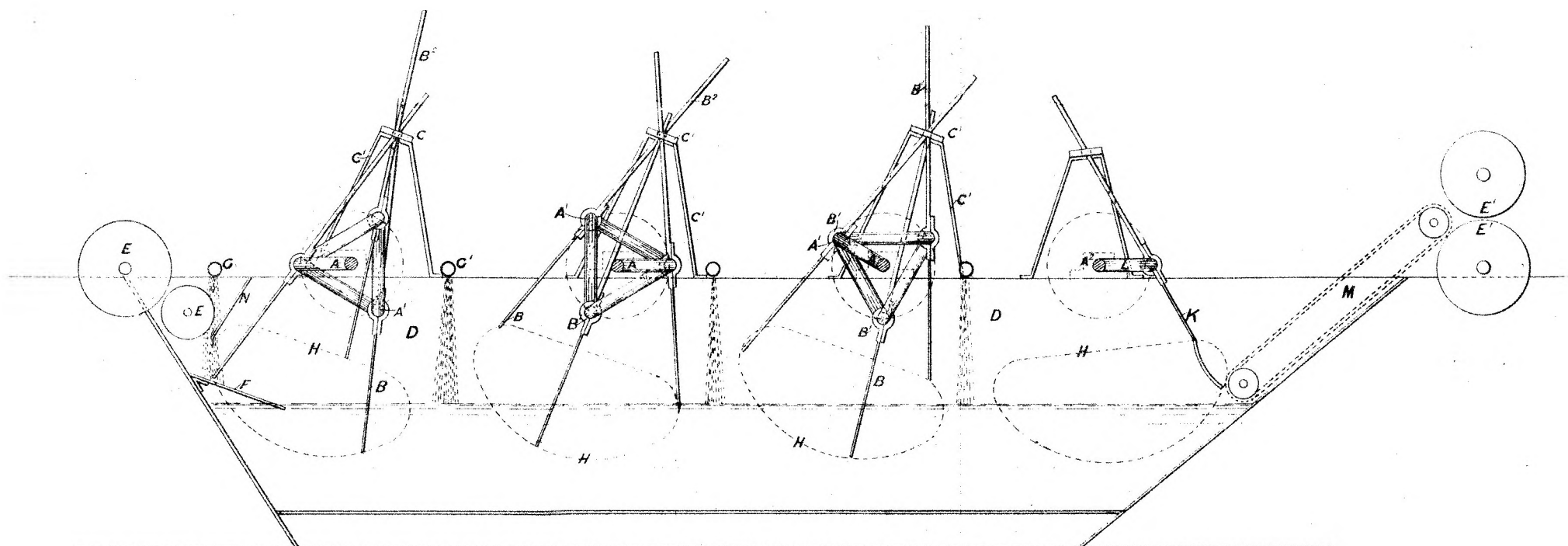


FIG: 4.



A.D. 1884, 16th April. No. 1412.

AN IMPROVEMENT IN WORKING BRAKES ON RAILWAY TRAINS.

LETTERS OF REGISTRATION to George Westinghouse, junior, for an Improvement in the connection of pipes for communicating fluid pressure to work Brakes on Railway Trains.

[Registered on the 18th day of April, 1884, in pursuance of Act 16 Vic. No. 24.]

BY HIS EXCELLENCY THE RIGHT HONORABLE SIR AUGUSTUS WILLIAM FREDERICK SPENCER LOFTUS (commonly called LORD AUGUSTUS LOFTUS), Knight Grand Cross of the Most Honorable Order of the Bath, a Member of Her Majesty's Most Honorable Privy Council, Governor and Commander-in-Chief of the Colony of New South Wales and its Dependencies.

TO ALL TO WHOM THESE PRESENTS SHALL COME, greeting:

WHEREAS GEORGE WESTINGHOUSE, junior, of Pittsburg, Pennsylvania, United States of America, hath by his Petition humbly represented to me that he is the author or designer of a certain invention or improvement in manufactures, that is to say, of an invention entitled "An improvement in the connection of pipes for communicating fluid pressure to work Brakes on Railway Trains," which is more particularly described in the specification and the sheet of drawings which are hereunto annexed; and that he, the said Petitioner, hath deposited with the Honorable the Treasurer of the said Colony of New South Wales the sum of Twenty Pounds sterling, for defraying the expense of granting these Letters of Registration, as required by the Act of Council, sixteenth Victoria, number twenty-four; and hath humbly prayed that I would be pleased to grant Letters of Registration, whereby the exclusive enjoyment and advantage of the said invention or improvement might be secured to him for a period of fourteen years: And I, being willing to give encouragement to all inventions and improvements in the arts or manufactures which may be for the public good, and having received a report favourable to the prayer of the said Petition, from competent persons appointed by me to examine and consider the matters stated therein and to report thereon for my information, am pleased, with the advice of the Executive Council, and in exercise of the power and authority given to me by the said Act of Council, to grant, and do by these Letters of Registration grant unto the said George Westinghouse, his executors, administrators, and assigns, the exclusive enjoyment and advantage of the said invention or improvement, for and during the term of fourteen years from the date hereof; to have, hold, and exercise unto the said George Westinghouse, his executors, administrators, and assigns, the exclusive enjoyment and advantage thereof, for and during and unto the full end and term of fourteen years from the date of these presents next and immediately ensuing, and fully to be complete and ended: Provided always, that if the said George Westinghouse shall not, within three days after the granting of these Letters of Registration, register the same in the proper office in the Supreme Court, at Sydney, in the said Colony of New South Wales, then these Letters of Registration, and all advantages whatsoever hereby granted, shall cease and become void.

In witness whereof, I have hereunto set my sign manual, and have caused the present Letters of Registration to be sealed with the seal of the said Colony of New South Wales, at Government House, Sydney, in New South Wales, this sixteenth day of April, in the year of our Lord one thousand eight hundred and eighty-four.

[L.S.]

AUGUSTUS LOFTUS.

An improvement in working Brakes on Railway Trains.

SPECIFICATION of GEORGE WESTINGHOUSE, junior, of Pittsburg, Pennsylvania, United States of America, for an invention entitled "An improvement in the connection of pipes for communicating fluid pressure to work Brakes on Railway Trains."

When the brakes of a railway train are worked by fluid pressure communicated by pipes extending throughout the train, these pipes have to be connected from carriage to carriage by flexible hose or multiple-jointed pipes, so as to allow for the oscillations of the carriages relatively to one another. These flexible pipe connections are liable to injury and deterioration, particularly when flexible hose pipes are used, and when rupture occurs of any one of them the working of the brakes throughout the train is seriously deranged or altogether prevented. In the case of the brakes being automatic, the rupture of one of the connections has the effect of putting on all the brakes of the train, which in certain circumstances might be productive of serious accidents; and when the brakes are not automatic the rupture of a connection prevents the brakes from being worked at all, and therefore involves very serious danger.

This invention relates to means of providing against such occurrences. For this purpose, instead of a single hose or a single set of jointed pipes for connecting from carriage to carriage, two separate hose pipes or two separate sets of jointed pipes are arranged to extend from a valve box attached to the fixed pipe on the one carriage to a similar valve box on the next carriage. Each of these valve boxes contains a duplex valve, which can seat itself in either of two positions, so as to close the one or the other, but not both of the two flexible branches. When these branches are sound, the valves in both boxes remain in an intermediate position, closing neither branch, so that there is free passage through both flexible pipes from the fixed pipe on one carriage to the fixed pipe on the next. But should either of the flexible connections become ruptured or so far damaged as to leak considerably, then, owing to the difference of pressure thus produced in the two branches, the valves seat themselves so as to close the mouths of the damaged branch, leaving the other branch, which is entire, in condition for efficient working of the brakes.

Some brakes are worked by transmission of compressed air along the train pipe, which therefore has normally within it a pressure above that of the external atmosphere. Some brakes, on the other hand, are worked by a vacuum, the train pipe having in that case within it a pressure below that of the external atmosphere. For these two cases the duplex valves have to be differently arranged, as will now be explained with reference to the accompanying drawings.

Fig. 1 is a longitudinal section and fig. 2 is a transverse section of the valve box for brake pipes having internal pressure above that of the atmosphere. Fig. 3 is a longitudinal section and fig. 4 is a transverse section of the valve box for brake pipes having internal pressure below that of the atmosphere. The middle chamber A of the valve box communicates by a branch B with the fixed pipe of the carriage. Each of the branches C C' is made as a nozzle to receive on it one of the flexible hose connections which forms the communication to a corresponding branch C or C' on the next carriage. When jointed pipes are used instead of flexible hose, the branches C C' are made of suitable form to connect to the joints of the pipe. In the sides of the middle chamber A are orifices, having round them valve seatings D D'. The seatings in figs. 1 and 2 are internal, to receive a ball valve E, which is guided by ribs F, along which it can freely move to seat itself either on D or on D'. When one of the flexible connections, such as that which is attached to C, gives way, the pressure in that connection becomes immediately reduced below that in A, and consequently the valve E seats itself, as shown in fig. 1, and as the valve on the next carriage takes a corresponding position, the damaged connection becomes thus cut off from the train pipe, the undamaged connection with its valve orifices D' open, maintaining the continuity of the communication throughout the train. The seatings D D' in figs. 3 and 4 are external, and two valves G G' are connected by ribs H, which serve as guides, so that the two valves can move to or fro together. When one of the flexible connections, such as that which is attached to C, gives way the pressure in that connection is immediately raised above that in A, where there is a partial vacuum, and consequently the valve G seats itself as shown in fig. 3, and as the corresponding valve on the next carriage also seats itself, the damaged connection becomes cut off from the train pipe, the undamaged connection, with its valve orifices D' open, maintaining the continuity of the communication throughout the train.

It is possible that when the increase of pressure above that of the atmosphere or the reduction of pressure below that of the atmosphere is first effected one or other of the orifices D D' might be closed by the valve, and if this closure continued the closed connection would be useless. To prevent this from occurring a little leakage is allowed past the valve by cutting a small groove such as L in one of the valve seatings, or drilling a small hole such as K through one side of the central chamber. The leakage through these small passages is sufficient to equalise in a short time the pressure in the two branches, but not sufficient to interfere with the working of the brakes when either connection is closed by its valves.

By thus employing two sets of flexible connections from carriage to carriage, instead of one set, the risk of accident is greatly diminished, as the simultaneous damage of both connections is highly improbable. The use of duplicate connections might be objected to, because it involves a double operation in coupling and uncoupling them when the carriages are brought together or taken apart. In order to remove this objection, the two flexible or jointed pipes proceeding from the two branches C C' of the valve box of one carriage, instead of extending to two separable couplings in the middle, and thence to the corresponding branches of the valve box on the next carriage, are connected to two branches of a similar valve box attached to one part of a single separable coupling. Thus in the connections from carriage to carriage there are four valve boxes of the kind described, one on each of the two carriages and one on each half of the single separable coupling between the carriages. This arrangement is shown at fig. 5, where B¹ B² are the two valve boxes, one on each of two coupled carriages, B³ B⁴ are the two similar valve boxes, one on each half of the single separable coupling X, and Y¹ Y² Y³ Y⁴ are the two pairs of flexible hose pipes, each pair connecting the valve box of a carriage to the valve box of the half coupling. By this arrangement all the advantages of the duplicate connections are maintained without duplication of the coupling or uncoupling operation, there being only one coupling to deal with between each pair of carriages.

Having

An improvement in working Brakes on Railway Trains.

Having thus described the nature of this invention, and in what manner the same is to be performed, I claim—

First—In combination with two sets of flexible hose or jointed pipes extending from carriage to carriage, each set having its own intermediate separable coupling, a pair of valve boxes each communicating with the fixed pipe of its carriage, and each provided with a duplex valve, substantially as and for the purpose herein set forth.

Second—In combination with two sets of flexible hose or jointed pipes connecting carriage to carriage with a single intermediate separable coupling, two pairs of valve boxes, each of the one pair communicating with the fixed pipe of its carriage, and each of the other pair communicating with one part of the coupling, and each provided with a duplex valve, substantially as and for the purpose herein set forth.

In witness whereof, I, the said George Westinghouse, junior, have hereto set my hand and seal, this twenty-eighth day of January, one thousand eight hundred and eighty-four.

GEORGE WESTINGHOUSE, JUN.
(By his Agent, EDWARD WATERS.)

Witness—

W. S. BAYSTON,
Patent Law Clerk, Melbourne.

This is the specification referred to in the annexed Letters of Registration granted to George Westinghouse, jun., this 16th day of April, A.D. 1884.

AUGUSTUS LOFTUS.

REPORT.

Sir,

In referenc to your B.C. of the 2nd instant, No. 84/1,315, forwarding a petition from Mr. George Westinghouse, jun., of Pittsburg, Pa., U.S.A., for Letters of Registration for an invention entitled "An improvement in the connection of pipes for communicating fluid pressure to work brakes on railway trains," we have the honor to report, after examination of the specification and plans accompanying the petition, that we consider that Letters of Registration should be granted for the invention referred to.

We have, &c.,

JOHN WHITTON.
E. O. MORIARTY.

The Under Secretary of Justice.

[Drawings —one sheet.]

FIG. 2.

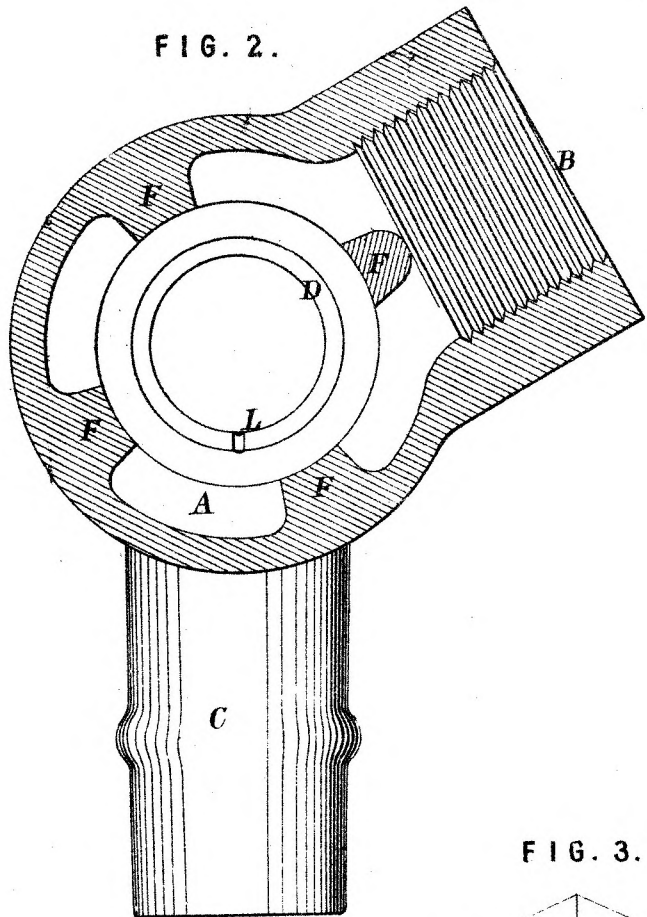


FIG. 1.

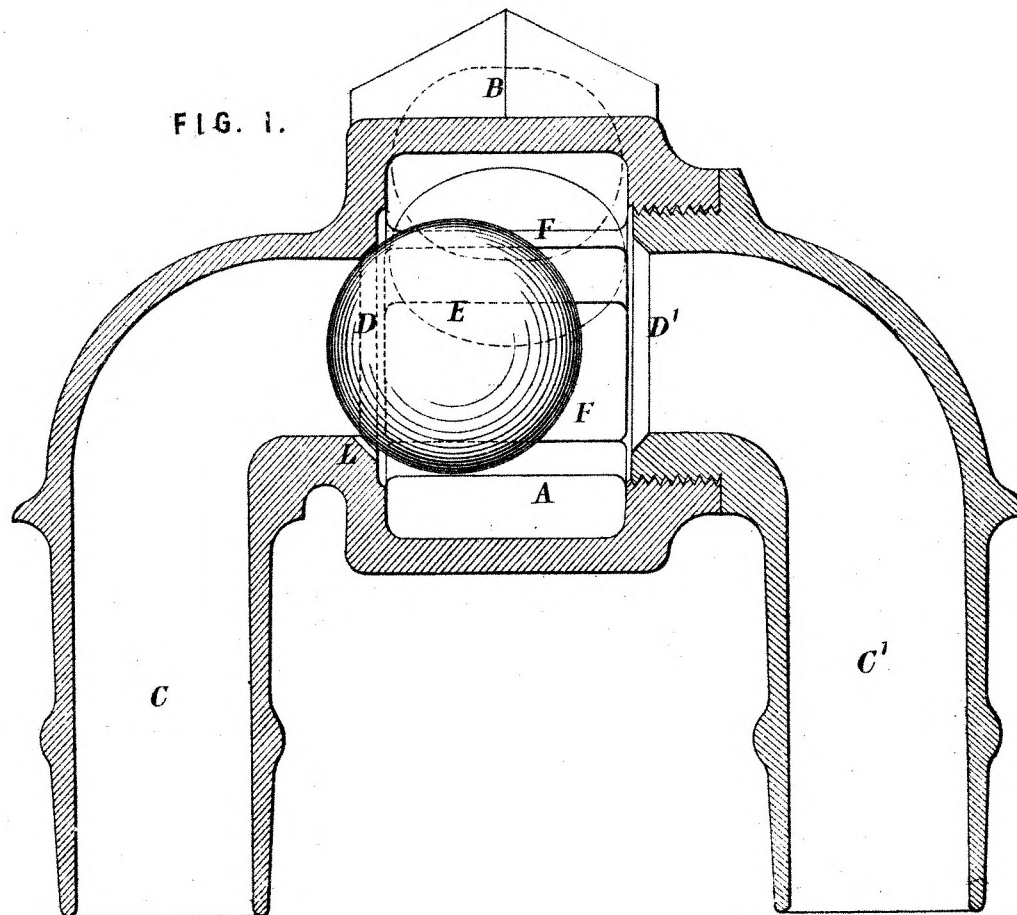


FIG. 3.

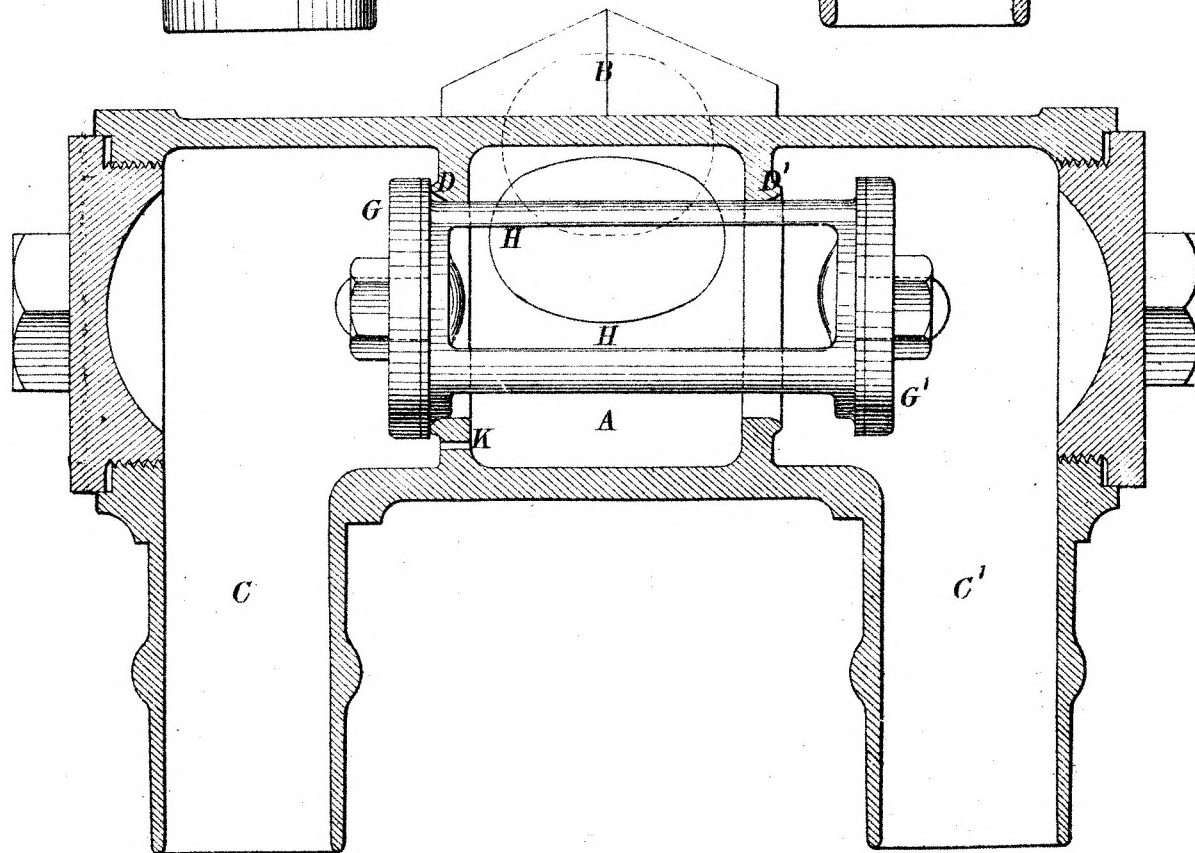


FIG. 4.

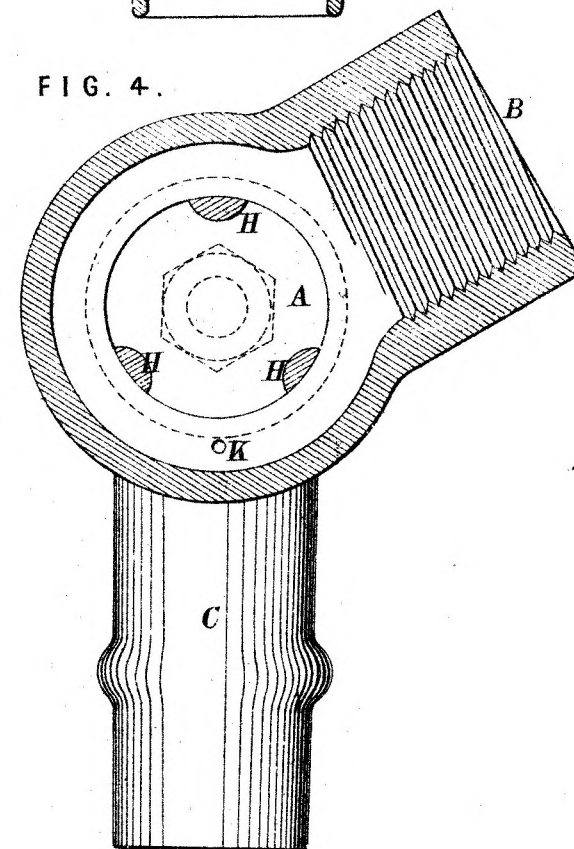
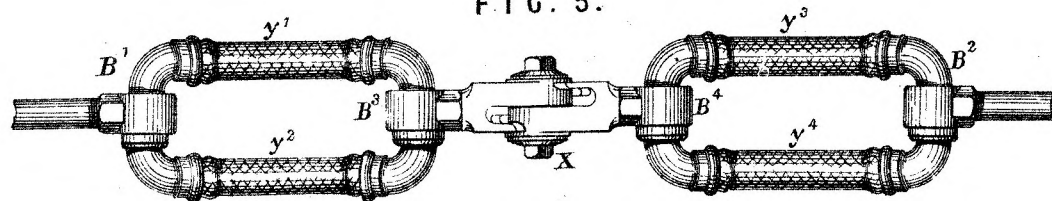


FIG. 5.



(Sig: 245~)

This is the Sheet of Drawings referred to in the annexed Letters of Registration, granted to George Westinghouse, Junr, this sixteenth day of April, A.D. 1884
Augustus Loftus.



A.D. 1884, 16th April. No. 1413.

IMPROVEMENTS IN MAKING ARTIFICIAL ICE.

LETTERS OF REGISTRATION to Thomas Douglas Kyle, for Improvements in apparatus for making Artificial Ice in blocks or slabs.

[Registered on the 18th day of April, 1884, in pursuance of the Act 16 Vic. No. 24.]

BY HIS EXCELLENCY THE RIGHT HONORABLE SIR AUGUSTUS WILLIAM FREDERICK SPENCER LOFTUS (commonly called LORD AUGUSTUS LOFTUS), Knight Grand Cross of the Most Honorable Order of the Bath, a Member of Her Majesty's Most Honorable Privy Council, Governor and Commander-in-Chief of the Colony of New South Wales and its Dependencies.

TO ALL TO WHOM THESE PRESENTS SHALL COME, greeting :

WHEREAS THOMAS DOUGLAS KYLE, of Sydney, in the Colony of New South Wales, engineer, hath by his Petition humbly represented to me that he is the author or designer of a certain invention or improvement in manufactures, that is to say, of an invention entitled "Improvements in apparatus for making Artificial Ice in blocks or slabs," which is more particularly described in the specification and the sheet of drawings which are hereunto annexed ; and that he, the said Petitioner, hath deposited with the Honorable the Treasurer of the said Colony of New South Wales the sum of Twenty Pounds sterling, for defraying the expense of granting these Letters of Registration, as required by the Act of Council, sixteenth Victoria, number twenty-four ; and hath humbly prayed that I would be pleased to grant Letters of Registration, whereby the exclusive enjoyment and advantage of the said invention or improvement might be secured to him for a period of fourteen years : And I, being willing to give encouragement to all inventions and improvements in the arts or manufactures which may be for the public good, and having received a report favourable to the prayer of the said Petition, from competent persons appointed by me to examine and consider the matters stated therein and to report thereon for my information, am pleased, with the advice of the Executive Council, and in exercise of the power and authority given to me by the said Act of Council, to grant, and do by these Letters of Registration grant unto the said Thomas Douglas Kyle, his executors, administrators, and assigns, the exclusive enjoyment and advantage of the said invention or improvement, for and during the term of fourteen years from the date hereof ; to have, hold, and exercise unto the said Thomas Douglas Kyle, his executors, administrators, and assigns, the exclusive enjoyment and advantage thereof, for and during and unto the full end and term of fourteen years from the date of these presents next and immediately ensuing, and fully to be complete and ended : Provided always, that if the said Thomas Douglas Kyle shall not, within three days after the granting of these Letters of Registration, register the same in the proper office in the Supreme Court, at Sydney, in the said Colony of New South Wales, then these Letters of Registration, and all advantages whatsoever hereby granted, shall cease and become void.

In witness whereof, I have hereunto set my sign manual, and have caused the present Letters of Registration to be sealed with the seal of the said Colony of New South Wales, at Government House, Sydney, in New South Wales, this sixteenth day of April, in the year of our Lord one thousand eight hundred and eighty-four.

[L.S.]

AUGUSTUS LOFTUS.

Improvements in apparatus for making Artificial Ice in blocks or slabs.

SPECIFICATION of THOMAS DOUGLAS KYLE, of Sydney, in the Colony of New South Wales, engineer, for an invention entitled "Improvements in apparatus for making Artificial Ice in blocks or slabs."

THE invention relates to improvements whereby the ice-boxes are made to produce a quantity of ice nearly equivalent to the heat abstracted by the freezing or cooling machine, and consists: Firstly, in certain improvements in connection with the cells, on the sides of which the ice is formed. Secondly, in an improved arrangement of the pipe and valve connections with the said cells, whereby the course of the cooling medium through the same can be reversed at pleasure in order to secure uniform thickness in the blocks or slabs of ice by one operation, and one box is made to thaw off the ice in another without employing a thawing-off pump, whereby no power whatever is lost, and the operation becomes a continuous reversible process.

In the drawings hereto annexed, figure 1 is a longitudinal section of a cell or flattened tube constructed in accordance with my invention; figure 2 shows transverse sections of two such cells with the ice blocks or slabs forming or formed thereon; figure 3 is a front elevation of a series of four ice-boxes showing my improved arrangements of the connections for conveying the cooling medium to and from the cells; and figure 4 shows a plan of one of such ice-boxes with the cells in place therein, and part of the connection with the said cells.

The cells or flattened tubes shown in figures 1 and 2 are made of iron, copper, zinc, or other suitable metal; they may be about $\frac{1}{2}$ inch wide, and divided horizontally by strips of wood screwed on to division-plates which divide the cells or tubes into two equal parts. These strips of wood divide the circulation of the cooling medium. The division-plate is studded with snags or pins which touch the plate of the cell or tube on either side, and thereby cut up the current of the cooling medium and cause fresh parts thereof to impinge continually against the inner surfaces of the said plates or sides of the cells or flattened tubes, whereby more heat is abstracted from such surfaces than if the snags or pins were not employed. In order to carry out the before-mentioned continuous reversible process, I prefer to employ four ice tanks or boxes, as shown in figures 3 and 4, each containing any required number of cells or flattened tubes, for example, three, as shown in figure 4. By this reversible process the cooling medium can be transmitted at will to any one of the ice-boxes that may be required, and the ice can thereby be made of uniform thickness without intermission, and in the event of any derangement taking place in any box, that box can be passed over till repairs are effected, and no stoppage of the machine is necessary. The front elevation, figure 3, shows the connections for effecting this continuous reversible process.

The cocks Nos. 1, 2, 3, 4, 5, 6, 7, and 8 are three-way cocks, and the cocks Nos. 9, 10, 11, 12, 13, and 14 are through-way cocks.

The pipes A, B, C, D are alternately delivery and suction pipes. The pipe E is the delivery from the cooling machine, and the pipe F is the return suction or overflow. The pipes g^1 , g^2 , g^3 , g^4 , g^5 , g^6 , g^7 , and g^8 are the cell connection pipes. The apparatus is worked as follows:—

Supposing the four ice-boxes, Nos. 1, 2, 3, and 4 (figure 3), to be filled with the water to be converted into ice, and that all the cocks are shut, the entrance for the cooling medium coming from the cooling machine being at E, and the outlet for same from the boxes at F. The cocks No. 11, No. 1, No. 2, and No. 14 are now opened, the medium now flows along the pipe A, through cock No. 1, it enters pipe g^1 , and passes from thence into the cells or flattened tubes in box No. 1. After traversing these cells it passes out by the pipe g^2 , and through the cock No. 2 to the pipe D, whence it escapes through the cock No. 14 to the outlet pipe F, to be returned to the cooling machine.

After the cooling machine has reduced the temperature down in box No. 1, the cock No. 3 is opened full to the delivery pipe A, the cock No. 4 is partially opened to the return pipe D, and as the temperature continues to fall the cock No. 4 is opened more and more until full open. The course of the medium is then changed so as to flow continually through No. 1 and No. 2 boxes, by opening cock No. 1 to pipe A, as before, cock No. 2 to pipe C, cock No. 4 to pipe C, cock No. 3 to pipe B, and cock No. 9 to pipes B and D. The medium is thus caused to enter box No. 1 by pipe g^1 , to leave same by pipe g^2 , to enter box No. 2 by pipe g^3 , to leave same by pipe g^4 , and to return to the cooling machine by pipe B, cock No. 9, pipe D, cock No. 14, and pipe F.

The temperature will continue to fall, and another will be required; the cock No. 5 is therefore opened to pipe A, and the cock No. 6 partially opened to pipe D; this is continued till the temperature again falls too low, and the cock No. 6 has been fully opened to suction pipe D. The course of the medium then changed so as to flow continuously through boxes Nos. 1, 2, and 3, by leaving cock No. 1 open to pipe A, cock No. 2 to pipe C, cock No. 4 to pipe C, cock No. 3 to pipe B, opening cock No. 5 to pipe B, cock No. 6 to pipe D, and shutting cock No. 9. The medium is thus caused to pass through boxes Nos. 1 and 2 successively, as before, then to enter box No. 3 by pipe g^5 , to leave same by pipe g^6 , and to return to the cooling machine by pipe D, cock No. 14, and pipe F. This circulation is continued for a time, and the ice in the boxes will be tapered in form as shown at z^1 in figure 2. The course of the medium must now be reversed so as to make the ice of uniform thickness. To effect this, cock No. 13 is opened, cock No. 2 is opened to pipe D, cock No. 1 to pipe B, cock No. 3 to pipe B, cock No. 4 to pipe C, cock No. 6 to pipe C, cock No. 5 to pipe A, cock No. 12 to pipe A, and cocks Nos. 14 and 11 are closed. The medium is then caused to enter box No. 1 by pipe g^7 , to leave same by pipe g^8 , to enter box No. 2 by pipe g^1 , to leave same by pipe g^2 , to enter box No. 3 by pipe g^3 , to leave same by pipe g^4 , and return to cooling machine by pipe A, cock No. 12, and pipe F. This circulation is continued until the ice formed on the cells or flattened tubes is of equal thickness, as shown at z^2 in fig. 2, when the ice will be ready for removal from box No. 1.

This removal of the ice is effected without a thawing-off pump in the following way:—The box No. 4 contains water to be frozen into ice at, say, 70° Fahrenheit, and the cooling medium from the cooling machine is caused to pass through the cells of this ice-box; first, it gets heated up therein, and is then passed through the cells of box No. 1, thawing the ice off from the cells before ice is formed in box No. 4. For this purpose, cock No. 8 is opened to pipe D, cock No. 7 to pipe B, cock No. 1 remains open to pipe B, cock No. 2 to pipe C, cock No. 10 to pipes A and C, cock No. 12 to pipes A and F, cock No. 13 remains open to pipe D, and cocks Nos. 3, 4, 5, 6, 9, 11, and 14 are closed. The medium is thus caused to enter box No. 4 by pipe g^5 , to leave same by pipe g^6 , to pass along by pipe B, and to enter box No. 1 by pipe g^1 , to leave same by pipe g^2 , to pass along by pipe C, cock No. 10, pipe A, cock No. 12, and pipe F, back to the cooling

Improvements in apparatus for making Artificial Ice in blocks or slabs.

cooling machine. The ice being now thawed off the cells in box No. 1, the cooling-machine is put in communication with box No. 2 as the first box, then box No. 3 as second, and box No. 4 as third; as the cooling machine only works on three boxes at one time, the remaining one is always the thawing-off box, and the surplus cold in the cold box is conveyed to the hot box. By this means no power whatever is lost, and a thawing-off pump is dispensed with.

Having now described the nature of the said invention, and the manner in which the same is to or may be carried into effect, I would have it understood that what I claim is—

- 1st. The employment of snags or pins in the cells or flattened tubes of ice-boxes for the purpose of cutting up the flow of the cooling medium, and causing fresh parts thereof to impinge continually against the surfaces of the said cells or flattened tubes, as hereinbefore described and illustrated in figs. 1 and 2 of the drawings hereunto annexed.
- 2nd. The arrangement of the connecting-pipes and cocks for conveying the cooling medium to and from the cells or flattened tubes of the ice-boxes in such manner that the course of the said cooling medium can be reversed so as to make the ice of uniform thickness, and also to effect the thawing-off of the ice from the cells or flattened tubes without requiring a thawing-off pump, as hereinbefore described and illustrated in figs. 3 and 4 of the drawings hereto annexed, and for the purposes herein specified.

In witness whereof, I, the said Thomas Douglas Kyle, have hereunto set my hand and seal, this sixth day of February, in the year of our Lord one thousand eight hundred and eighty-four.

Witness—

FRED. WALSH,
Manager, Edwd. Waters' Patent Office, Sydney.

THOMAS D. KYLE.

This is the specification referred to in the annexed Letters of Registration granted to Thomas Douglas Kyle, this sixteenth day of April, A.D. 1884.

AUGUSTUS LOFTUS.

REPORT.

Sir,

Sydney, 16 February, 1884.

The Petition of Mr. Thomas Douglas Kyle, for Letters of Registration for an invention entitled "Improvements in apparatus for making Artificial Ice in blocks or slabs," having been referred to us, we have examined the specifications and drawing accompanying the same, and have now the honor to report that we see no objection to the issue of Letters of Registration as prayed for.

We have, &c.,
J. SMITH.
A. LEIBJUS.

The Under Secretary of Justice.

[Drawings—one sheet.]

T. D. KYLE'S PATENT.

FIG I

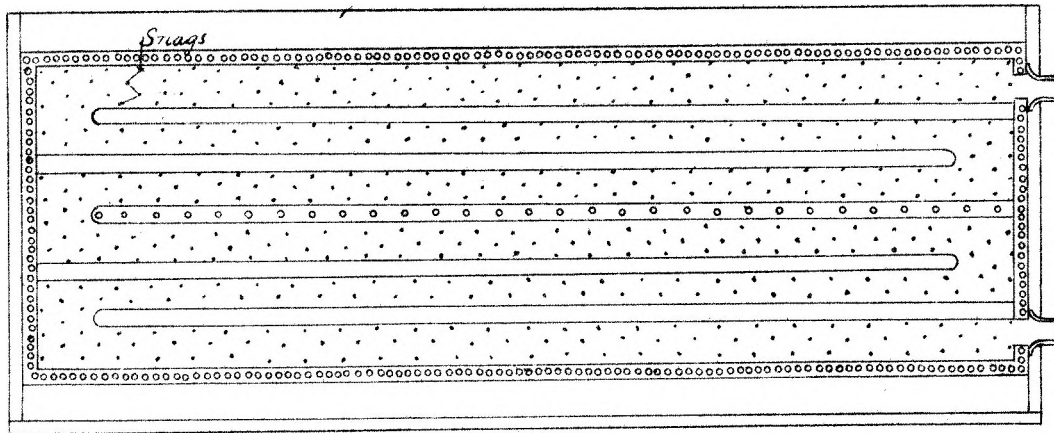


Fig II

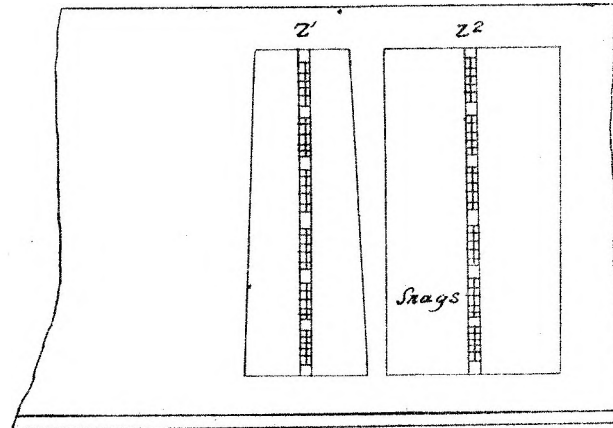


FIG IV

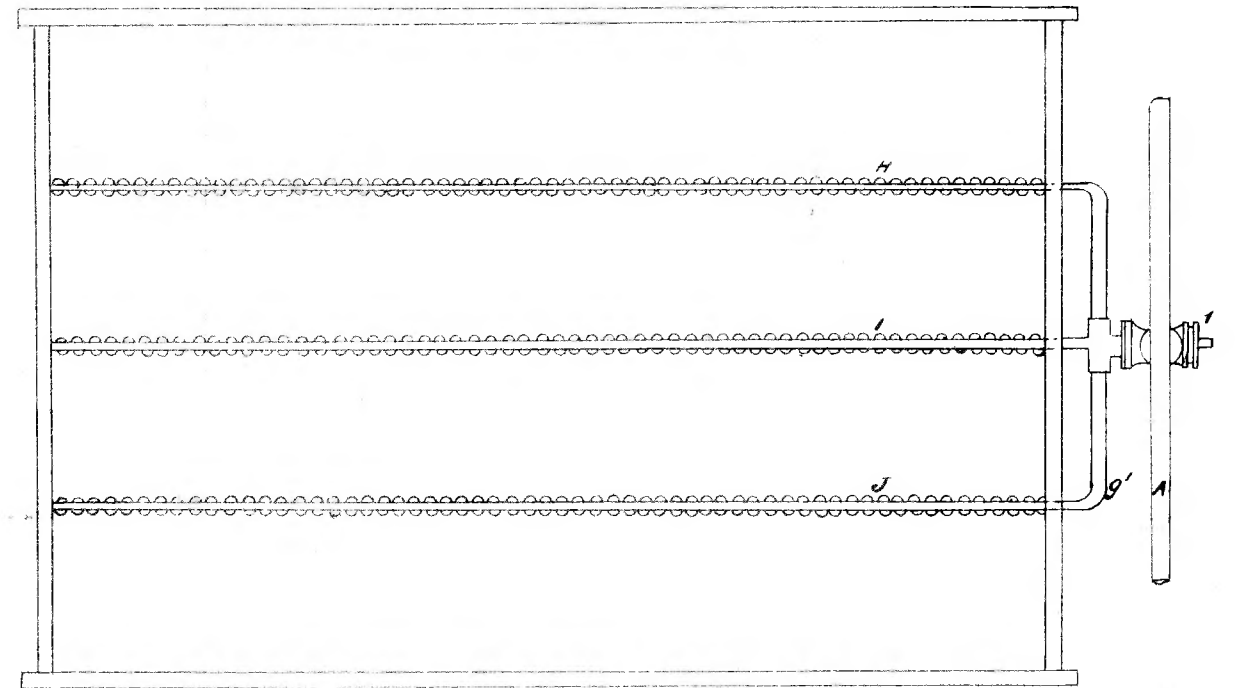
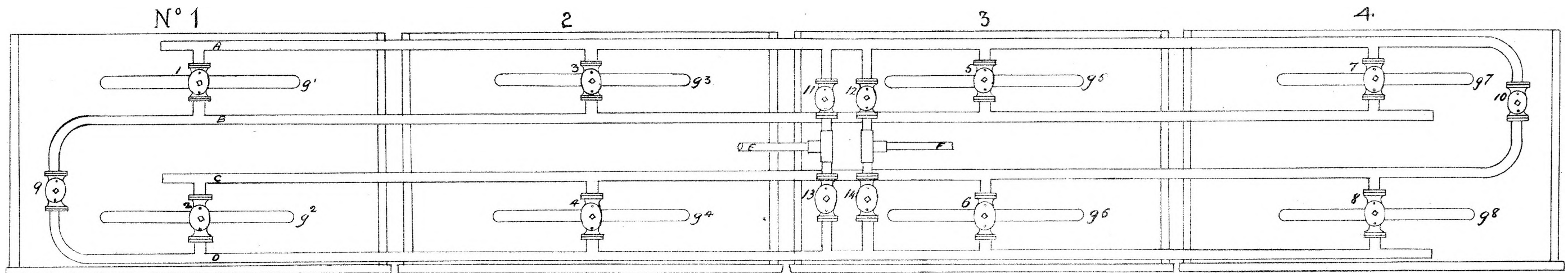


FIG III



This is the Sheet of Drawings referred to in the annexed Letters of Registration, granted to Thomas Douglas Kyle, this sixteenth day of April, A.D., 1884. Augustus Loftus.

(Sig: 245)



A.D. 1884, 17th April. No. 1414.

IMPROVEMENTS IN REFRIGERATOR CARS.

LETTERS OF REGISTRATION to Cassius Clay Palmer, for Improvements in Refrigerator Cars.

[Registered on the 18th day of April, 1884, in pursuance of the Act 16 Vic. No. 24.]

BY HIS EXCELLENCY THE RIGHT HONORABLE SIR AUGUSTUS WILLIAM FREDERICK SPENCER LOFTUS (commonly called LORD AUGUSTUS LOFTUS), Knight Grand Cross of the Most Honorable Order of the Bath, a Member of Her Majesty's Most Honorable Privy Council, Governor and Commander-in-Chief of the Colony of New South Wales and its Dependencies.

TO ALL TO WHOM THESE PRESENTS SHALL COME, greeting :

WHEREAS CASSIUS CLAY PALMER, of Oakland, in the State of California, United States of America, hath by his Petition humbly represented to me that he is the author or designer of a certain invention or improvement in manufactures, that is to say, of an invention entitled "Improvements in Refrigerator Cars," which is more particularly described in the specification which is hereunto annexed and the three sheets of drawings marked "A," "B," and "C," respectively, and which are also hereunto annexed ; and that he, the said Petitioner, hath deposited with the Honorable the Treasurer of the said Colony of New South Wales the sum of twenty pounds sterling, for defraying the expense of granting these Letters of Registration, as required by the Act of Council, sixteenth Victoria number twenty-four ; and hath humbly prayed that I would be pleased to grant Letters of Registration, whereby the exclusive enjoyment and advantage of the said invention or improvement might be secured to him for a period of fourteen years : And I, being willing to give encouragement to all inventions and improvements in the arts or manufactures which may be for the public good, and having received a report favourable to the prayer of the said Petition from competent persons appointed by me to examine and consider the matters stated therein and to report thereon for my information, am pleased, with the advice of the Executive Council, and in exercise of the power and authority given to me by the said Act of Council, to grant, and do by these Letters of Registration grant unto the said Cassius Clay Palmer, his executors, administrators, and assigns, the exclusive enjoyment and advantage of the said invention or improvement, for and during the term of fourteen years from the date hereof ; to have, hold, and exercise unto the said Cassius Clay Palmer, his executors, administrators, and assigns, the exclusive enjoyment and advantage thereof, for and during and unto the full end and term of fourteen years from the date of these presents next and immediately ensuing, and fully to be complete and ended : Provided always, that if the said Cassius Clay Palmer shall not, within three days after the granting of these Letters of Registration, register the same in the proper office in the Supreme Court, at Sydney, in the said Colony of New South Wales, then these Letters of Registration, and all advantages whatsoever hereby granted, shall cease and become void.

In witness whereof, I have hereunto set my sign manual, and have caused the present Letters of Registration to be sealed with the seal of the said Colony of New South Wales, at Government House, Sydney, in New South Wales, this seventeenth day of April, in the year of our Lord one thousand eight hundred and eighty-four.

[L.S.]

AUGUSTUS LOFTUS.

Improvements in Refrigerator Cars.

SPECIFICATION of CASSIUS CLAY PALMER, of Oakland, in the State of California, United States of America, for an invention entitled "Improvements in Refrigerator Cars."

THE object of my invention is to construct a machine which may be used to advantage to refrigerate air in railroad cars, by means of the compression, cooling, and expansion of a volatile fluid; and which machine is also especially adapted for employing chloride of ethyl as the volatile fluid.

In the drawings, figure 1 represents a vertical section through the line 1, 1, of figure 3.

Figure 2 represents a vertical section through the line 2, 2, of figure 3, the casing of the condenser being partially broken to show the arrangement of pipes within.

Figure 3 is a vertical transverse section through the line 3, 3, figure 1.

Figures 4 and 5 represent detailed views of the belt tightening mechanism.

Figures 6 and 7 represent two views of the pump used for communicating the expansive force of the air to compress the volatile fluid.

Figure 8 represents a section through the cylinders of the pump or engine on the line *z, z*, figure 7.

Figure 9 represents a cross-section of the same thing on the line *y, y*, of figure 6.

Figure 10 represents in detail the casing and absorbent covering of the air compressing cylinders.

The apparatus may be divided into two parts.

First—The apparatus, by means of which the gas compressing engine is driven.

This apparatus may be used on cars to advantage for driving engines or other machines, such as dynamo machines, which may be located on the car for generating electricity for electric lighting or other purposes.

Second—The apparatus for compressing the gas, cooling it, expanding it, and conducting the air into such proximity to it, that the heat of the air is absorbed by the gas.

When my apparatus is applied to a refrigerating car, the walls of the car are constructed in a non-conducting manner, and the interior of the car is divided into four compartments, as follows:—

A is the compartment where the articles to be refrigerated are placed, and which, when used for meat, is provided at its top with rods *a a*, running longitudinally along the ceiling, to which are attached the meat-hooks *a' a'' a''' a''''*. A suitable air duct or ducts is arranged within this chamber for the purpose of distributing or drawing off the air at such points as to keep up an equable distribution of the cold air among the articles being refrigerated. In the drawing this duct is represented at *b* as extending longitudinally along the centre of the ceiling of the car with perforations at frequent intervals, and into which the air from the car is drawn.

B is a compartment which is preferably located, as shown, at one end of the apartment A, and which is used for enclosing a fan-blower (in case a fan-blower is used) and the refrigerator of the air cooling apparatus. The air-duct *b*, in the arrangement shown in the drawings, connects with this compartment B at its top, and an oblong opening *b'* extends preferably all the way across the car, connecting the bottom of the compartment B with the bottom of the compartment A. By this arrangement, when the fan-blower *c* is revolved in the manner hereinafter referred to, the air is drawn into the openings of the duct *b*, conducted into the compartment B, where it comes into contact with the refrigerator of the air cooling apparatus, and whence it is discharged through the opening *b'*, and into the compartment A, to be again drawn into the duct *b*, and the operation repeated. The arrows in figure 1 represent the direction taken by the air in being thus circulated.

C is the compartment in which is placed the machinery for compressing the volatile fluid, and this compartment is preferably separated from the compartment B by a non-conducting wall, as shown.

D, figure 3, is a compartment within which the condenser for cooling the volatile fluid is enclosed. This compartment D in the drawing is represented as L shaped and extending partly across the ceiling of the compartment C, and partly down one side of said compartment.

I will now describe the apparatus which I prefer to use for applying power to drive the gas compressing engine.

In constructing an apparatus of this kind on a railroad car, to receive power from the axle of the car, it is desirable that provision should be made so that the varying speeds at which the axle revolves shall not produce a corresponding variation at the point of application of the power. It is also desirable that while the axles are revolving sufficient power should be stored to continue to drive the apparatus for a considerable time after the revolution of the axle has ceased to provide for the detentions which a railroad car is subject to.

Upon one of the axles *d*, I place a pulley 1; around this pulley is placed a driving-belt *e*, which extends through an opening of the floor of the car and around the driven pulley 2, which also acts as a fly-wheel of the air-compressing engine. The air-compressing engine is preferably located in one corner of the compartment C, and is of any ordinary construction, though I prefer to have it constructed with two single-acting cylinders, 3 4 (figures 3 and 10), enclosed within a wooden casing *f*, which confines a jacket of air around the cylinders 3 4, and prevents the compartment C becoming heated from those cylinders. To still further carry off the heat generated by compressing the air in these cylinders 3 and 4, I locate a funnel *g* upon the roof of the car and connect it by a pipe *g'* with the interior of the casing *f*. Another pipe, not shown in the drawing, is arranged to connect the interior of the casing *f* with the outside atmosphere in any convenient way so that the motion of the car causes air to enter the funnel *g*, and thence through the pipe *g'* into the casing *f*, whence it escapes through the other air-duct already referred to, and thus the air within the casing *f* is constantly changed, and the heat generated by the compression cylinders is carried off into the open air. The carrying off of this heat may be still further facilitated by enveloping the cylinders within the casing *f* with a wrapping of absorbent fibrous material, shown in figures 2 and 10 at *f'*. When this fibrous material is used, a water-pipe *f''* is arranged to convey to it a very small quantity of water from the water reservoir situated on top of the car so as to keep the fibrous material *f'* constantly moist, and thereby aid the removal of the heat from the cylinders 3 4 by the evaporation of the water.

The

Improvements in Refrigerator Cars.

The pistons within the cylinders 3 4 are driven from the same crank-shaft 5, provided with two fly-wheels 2 and 6. The suction pipe of this air-compressing engine may be arranged in any suitable manner to take the air to be compressed, either from the atmosphere outside of the car or from the atmosphere within the chill room of the car, though in the arrangement shown in the drawing the air to supply the air pump enters into the compartment D, through the funnel *h*, passes in contact with the outside of the pipes of the condenser, and is thence conducted to the cylinders of the air-compressor through the pipe *i*. In this pipe, between the chamber D and the compression cylinders, is introduced an automatic cut-off valve *j*, which is connected by a pipe *j'* with the discharge pipes from the compression cylinders in such a way that when the compression of the air in these discharge pipes reaches a certain point the supply of air to the compression cylinders will be automatically cut off and they will be run in a vacuum, thus preventing the performance by them of unnecessary work. 7 7 are the discharge pipes from the air-compressing cylinders, which serve to conduct the compressed air from those cylinders to one or more compressed air receptacles, such as 8 8 8 8, which are shown as located under the car, but which may be located on top or at any other convenient place. These compressed air receptacles are preferably made in the form of cylinders, extending preferably longitudinally under the car, and constructed as long as the distances between the trucks will permit. They are preferably about 14 inches in diameter and about four in number, though their size and number may be increased or diminished as the space will permit.

A check valve 9 is located in each pipe 7, to prevent any air from returning from the cylinders 8 8 8 8 to the compressing cylinders 3 4.

10 is a pipe connecting the compressed air cylinders 8 with the gas-compressing engine, and in this pipe is located a check valve 11, which prevents any compressed air which has passed out of the cylinders 8 from returning thereto.

For the purpose of supplying the compressed air at a uniform pressure to the fluid-condensing pump, I introduce in the pipe 10 an automatic pressure reducing valve *k*, and a compressed air reservoir *l*. By setting the valve *k* at the pressure requisite for driving the fluid-compressing pump, the reservoir *l* is made to contain compressed air always at that pressure, and hence the velocity of the fluid-compression pump is preserved constant, no matter how high the pressure in the cylinders 8 8 8 8 may become.

Figures 4 and 5 show a mechanism for keeping the driving-belt *e* tight, and yet allowing for sufficient extension of it to provide for the passing of the car around curves, and for the action of the springs of the car. An elevation of this mechanism is shown in figures 2 and 4. This tightening mechanism consists of two friction rollers 12 12, mounted upon guides 13 13. The belt *e* is passed between the rollers 12 12, as shown in figure 2, which are caused to bear against it on each side by suitable mechanism for pressing the rollers towards each other with a yielding pressure. This mechanism, as shown in the drawing, consists of the combination of a lever 14, pivoted to the bearings of one of the pulleys 12, provided on its longer arm with a weight and having its short arm secured to a spiral spring *u*, which is connected with the bearings of the other pulley, and is of such length that when the two rollers are pressing against the belt from opposite directions the weight will be raised in the position indicated in figures 2 and 4. In passing around curves the belt will sometimes be inclined so that one side of it would tend to press more heavily upon the pulleys 12 12 than the other side. To avoid this inequality of pressure, the connections between the axles of the pulleys 12 12 and the sliding carriages *t t* in which the bearings of these axles are located are made in the form of universal joints, so as to permit the two pulleys to occupy positions in the guides 13, which will cause the pulleys to be inclined in accordance with the inclination of the belt.

For the purpose of preventing cinders or dust coming in contact with the pulley 1 or belt or other parts of the apparatus, I surround the pulley 1 on three sides by a metallic box or case 15, which is firmly secured to the stationary spring timber *m* of the truck by a bracket, as shown in figure 2. This casing 15 is connected with the floor of the car by a flexible (preferably canvas) apron *n*, which excludes dust or ashes, and at the same time permits of the relative motion between the truck and body of the car.

The operation of the mechanism which I have just described for driving the gas engine is as follows: The motion of the car axle is communicated to the air-compressing pump through the medium of the driving-belt, which belt is kept tight by the mechanism shown in figures 4 and 5. The air-compressing engine takes air either from the outside atmosphere or from the interior of the chill room, compresses it, and forces it through the pipe 7 into the cylinders 8 8 8 8, where it is retained under pressure. In order to prevent the pressure of the air within the cylinders 8 8 8 8 from rising beyond a certain point, I adopt either of two devices. I either place in the pipe 7 a poppet-valve, which is regulated to blow off at the pressure which I desire to keep in the cylinders, or I place in the suction-pipe of the air-pump a cut-off valve, which is governed by the pressure generated in the pipe 7 and the cylinders 8, so as to close the suction-pipe when the pressure reaches a certain point and cause the pump to run under a vacuum. The latter is the arrangement which I have shown in the drawings. In this manner any desired pressure of air can be produced in the cylinders 8, which in practice will be in the neighbourhood of from 80 to 100 pounds. The pressure requisite for compressing chloride of ethyl (if that is the volatile fluid used) is only from 10 to 20 pounds. In order to supply the compressed air from the cylinders 8 to the cylinders of the gas-compressing engine uniformly at about this pressure, I place in the pipes 10 one of the well-known forms of valve which is adapted for automatically regulating the pressure at which the air is supplied to the gas-compressing pump. By this arrangement air is stored in the cylinders 8, under pressure, which will continue to operate the gas-compressing pump for a considerable time after the car has stopped, and the pressure under which the air is supplied to the gas-compressing pump continues to be uniform, independent of any variation in the velocity of rotation of the axle of the car. This result is facilitated and insured by the interposition of the cylinder *l* in the pipe 10.

The apparatus which I have just described may be used to advantage on cars for running apparatus other than the refrigerating apparatus which I am about to describe, and I do not intend to limit myself to its application to refrigerating apparatus, excepting where such limitation is expressed in the claims.

Having described the apparatus which supplies and stores power to drive the gas engine, I will now proceed to describe the arrangement of the apparatus by which the refrigeration of the air within the

car

Improvements in Refrigerator Cars.

car is produced. This apparatus consists of three principal parts—(1) The gas-compressing pump, which is shown in figures 1, 3, 5, 6, 7, and 8; (2) the condenser, which is shown in figures 1, 2, and 3; (3) the refrigerator, which is shown in figures 1 and 2.

I prefer to arrange the gas-compressing engine on the opposite side of the compartment C from that occupied by the air-compressing pump already referred to, and sufficiently distant from the end of the car to provide room between it and the end of the car, and at one side of the air-compressing pump, for an attendant to enter for the purpose of oiling or regulating the machinery. This gas-compressing pump contains two cylinders—an air cylinder 16, about 4 inches in diameter by 10 inches long, and a gas cylinder 17, about 5 inches in diameter and 8 inches long, and each provided with a piston connected with the same crank-shaft 18. The compressed air is admitted into the cylinder 16 through the pipe 19 leading from the reservoir *l*, which pipe is provided with a valve which is connected with suitable mechanism for cutting the air off at about half stroke in each direction so that the latter half of each stroke is performed by the expansion of the air in the cylinder 16. The cylinder 16 is a double-acting cylinder, and its ends project sufficiently beyond the ends of the cylinder 17 to permit the escape passages 20 and 21 for the expanded air from the cylinder 16 to pass within the heads of the cylinder 17, as shown in figure 9.

By this construction, the expanded air, which, by reason of its expansion, is lowered in temperature, absorbs some of the heat from the gas being compressed in the cylinder 17, and a considerable amount of economy is produced. The capacity of the cylinder 16 is preferably made about the same as the capacity of the cylinder 17, and for this purpose the diameter of the cylinder 16 is made sufficiently less than the diameter of the cylinder 17, to compensate for the extent to which the length of the cylinder 16 exceeds the length of the cylinder 17. By having the cylinder 16 longer than the cylinder 17, as described, not only is the economy already referred to produced, but the additional length of stroke which is thus afforded enables the expansion of the air to take place with greater efficiency in the cylinders, and less air is required to produce the required results. As a means of accomplishing further economy, I construct around the air-expanding cylinder 16, a chamber 22, shown in figures 8 and 9. 23 is an outlet from the cylinder 17 to the chamber 22, through which compressed gas escapes from the cylinder 17. 24 is an outlet pipe from the chamber 22, through which the compressed gas is conducted to the condenser. This construction causes the gas, after being compressed in the cylinder 17, to traverse the chamber 22 surrounding the cylinder 16, and the exterior of the cylinder being cooled by the expansion of the air within it, a considerable quantity of the heat in the compressed gas passing around it is absorbed by said cylinder, which not only produces economy of cold but also prevents the accumulation of frost on the exterior of the cylinder 16, which would be the case if said cylinder was exposed to the ordinary action of the atmosphere, and also prevents the accumulation of frost or ice in the valves, since in circulating through the chamber 22 the compressed gas also passes around the cut-off valve contained within the pipe 19. It will be understood that the relative lengths of the cranks on shaft 18 are properly regulated in accordance with the difference in length of stroke required by the two cylinders 16 and 17.

25 and 26 are fly-wheels located on the crank-shaft 18. Around one of these fly-wheels, as 25, may be passed a belt *o*, so as to drive the fan *e*, through the medium of the pulley *p* located upon its shaft, which for that purpose extends through the partition between the compartments D and C.

The passages 20 and 21, already referred to, are connected by pipes 20 and 21 with the pipes 27 and 28. One of these pipes 27, leads to the chamber D, and serves to conduct a portion of the expanded air from the gas-compressor, which is at a somewhat low temperature, into the chamber D surrounding the condenser, where it absorbs heat from the condenser and passes thence through a suitable opening out into the atmosphere. The other of these pipes 28 leads into the compartment B, and serves to conduct a portion of the expanded air into the chamber B, where it mingles with the atmosphere of the chill room and serves to supply any leakage of air from that chamber, and at the same time to keep up a slight internal pressure of the atmosphere within that chamber, so as to prevent the entrance of dust and heated air which would otherwise be carried into the chamber through crevices by any external air which might enter. The discharge of this pipe 28 is preferably located, as shown, in the upper portion of the compartment B, so that the expanded air may be still further cooled by contact with the refrigerator before it escapes into the chill room proper. In case the suction-pipe of the air-compressing pump, instead of being connected with the atmosphere, is, as already suggested, connected with the chill room of the car, then the pipe 27, instead of being connected with the chamber B surrounding the condenser, should be omitted, and the pipe 28 made sufficiently large to discharge all of the expanded air into the chamber B, where it would be cooled by the refrigerator preparatory to being returned to the chill room.

30 is the pipe through which the gas is supplied to cylinder 17 for compression. This gas is taken from the refrigerator, with the interior of which the pipe 30 is connected at the top, as shown in figures 1, 2, and 3.

The refrigerator is located within the chamber B, and consists preferably of two or more horizontal parallel pipes 31, connected with one another, and extending through the chamber B from one side of the car to the other near its top, and also two or more similar pipes connected with one another and extending horizontally through the chamber B near its bottom from one side of the car to the other. These pipes 31 are preferably each about $2\frac{1}{2}$ inches in diameter. 32 are vertical pipes, each about 1 inch in diameter, which connect the upper and lower pipes 31 at frequent intervals along their length, there being about $1\frac{1}{4}$ inch space between each pair of pipes 32. 33 is a pipe connecting the refrigerator with the condenser, through which pipe the compressed gas is conducted from the condenser in which it is cooled to the refrigerator in which it is expanded. In this pipe 33 a valve 34 is located, which may be adjusted so as to regulate the supply of liquified gas and keep the area of the supply opening sufficiently small with reference to the exhaust pipe 30, for the purpose of causing the gas pump to produce a partial vacuum within the pipes 31 and 32 of the refrigerator, and thus cause the gas admitted through the pipe 33 to be expanded in a partial vacuum.

If found desirable, within the chamber B, and around pipes 32 of the refrigerator, deflectors may be located for causing the air, in its passage through the chamber, to take a circuitous passage around the pipes and thus be brought in close contact with them for the purpose of being cooled.

The

Improvements in Refrigerator Cars.

The condenser is shown in figures 1, 2, and 3, and is located within the compartment D, which, for economy of space, I prefer to arrange in such manner that it projects above the space occupied by the air and gas compressing pumps and to a short distance at the side of said space. The condenser itself consists of two pipes 36 and 37, which are about 2 inches in diameter, and extend horizontally across the chamber D, in about the position shown. These are connected by the pipes 38 at frequent intervals, such pipes being about 1 inch in diameter. 39 is a pipe connecting one end of the condenser with the gas-compressing engine; and, as already stated, the other end of the condenser is connected with the refrigerator by the pipe 33. For the purpose of removing the heat from the compressed gas passing through the pipes of the condenser, I cause a portion of the expanded air escaping from the gas pump in the cold state to pass through the chamber D, as already described, or in case this shall not be considered sufficient to sufficiently cool the gas within the condenser, I arrange a tank *q* upon the roof of the car, from which a suitable pipe conducts water into the chamber D and distributes it upon the absorbent fibrous covering *r* which lays in contact with the pipes of the condenser. In addition to this covering, I also prefer to envelop each of the pipes of the condenser with a thin wrapping of some material like linen lawn; the object of both this envelope and the covering *r* being to absorb the water received from the tank *q* and distribute it in contact with the pipes, so that by its evaporation the cooling of those pipes are greatly facilitated.

When it is preferred, a funnel *h* may be arranged upon the outside of the car connecting with the chamber D surrounding the condenser in such manner that the motion of the car in running will cause a current of air to be received in the funnel and conducted thence over the pipes of the condenser and allowed to escape through openings in the rear of the car, or, as shown, through the funnel *s*; or any of the means already pointed out for cooling the condenser may be used in connection with the others.

The operation of the apparatus for refrigerating the air may be described as follows:—The compressed air for driving the gas compressor having been stored in the cylinders 8, as already described, is, in the manner already described, delivered to the gas-compressing pump so as to drive the same at a uniform rate of speed, and in passing from the air-expansion cylinder of the gas-compressing pump, it passes, as already described, through such passages adjacent to the compression cylinder, as to absorb considerable of the heat which is generated by the compression of the gas. The gas, after being compressed in the cylinder 17 by the power thus supplied, is conducted thence through pipe 39 to the condenser, where it remains sufficiently long to be cooled by contact with the circulating air or water surrounding the pipes of the condenser. Having been cooled within the pipes of the condenser, the gas, in a liquid condition, passes through pipe 33 to the pipes 31 and 32 of the refrigerator, within which it is expanded in a partial vacuum so as to produce intense cold. The intensity of this cold can be regulated to a considerable extent by means of the valve 34 already described within the pipe 33, which regulates the extent of vacuum under which the gas is expanded. From the refrigerator the gas in the expanded state is conveyed, through the pipe 30, back to the gas-compressing pump, after which the same operation is repeated upon the gas.

The air within the chill room passes up through openings in the pipe *b*, and is conducted through said pipe into the chamber B surrounding the cold pipes of the refrigerator, and having been in contact with said pipes a sufficiently long time to be cooled, the said air escapes through the opening *b'*, or conduits connected with said opening, back into the chill room. This circulation may be intensified by the operation of the fan-blower *c*.

The volatile fluid which I prefer to employ in working my apparatus is chloride of ethyl, because it possesses many advantages; but other fluids may be employed to advantage.

It will be noticed that by the arrangement of the check-valve 34 in the supply-pipe 33 the fluid is practically under compression up to the point of the check-valve, and the vacuum under which the expansion of the fluid takes place does not commence until the check-valve is passed. This check-valve is located in the pipe 33, near to where that pipe enters the pipes 31 of the refrigerator, so that the greater part of the expansion of the gas takes place in the lower pipes 31 of the refrigerator, and whatever crystals are formed in this expansion are practically deposited in these enlarged pipes 31, so as not to obstruct the flow of gas. In case any are deposited in the pipe 33, between the check valve 34 and where that pipe enters the refrigerator, the rapid flow of the fluid through that short section of pipe will be sufficient to force the crystals out into the refrigerator, so as to prevent any obstruction of the pipes. In practice, with the proportions of pipes shown, no part of the apparatus becomes clogged by the deposition of crystals, since in practical use the amount deposited in the pipes 31 will not be sufficient to obstruct the passage by reason of their enlarged area in comparison with the supply-pipe, and whenever the operation of the apparatus ceases, as it does at the end of the trip, when the car is opened the crystals spontaneously evaporate by reason of the increase of temperature.

It will be noticed that the bottom of the condenser is above the level of the bottom of the refrigerator, so that no liquified gas will accumulate in any part of the apparatus below the refrigerator. The chloride of ethyl will exist in the upper portion of the condenser in a gaseous state, which, as it gradually is converted by being cooled into a liquid condition, will accumulate to a limited depth at the bottom of the condenser.

This liquid flows through the connecting pipe into the bottom of the refrigerator, and, in the relative arrangement shown in the drawing, will accumulate in the refrigerator to a depth of from about $\frac{1}{2}$ to $\frac{2}{3}$ the height of the refrigerator. As it absorbs heat through the pipes of the refrigerator it is converted into a gas which bubbles up through the liquid and accumulates at the top of the refrigerator, whence it is drawn off by the suction-pipe of the gas-compressing engine with sufficient rapidity to preserve a partial vacuum in the upper part of the refrigerator.

The construction of refrigerator shown presents an extended surface of the liquified gas from which the vaporized gas may readily escape from the various parts of the liquid where it is formed.

In comparison with other systems which have been employed for refrigerating cars, I believe that my method herein described is superior in very many respects, among which may be mentioned that it requires less space in the car, requires no ice, and therefore may be run at a very much less cost to preserve a temperature which may be kept practically uniform; it removes the moisture and impurities from

Improvements in Refrigerator Cars.

from the air and keeps it perfectly pure and dry; and at the same time, if need be, it may be used with all the advantages of a forced circulation through the chill room. So far as I am aware, the system which I have described is the first which has been devised by means of which the use of ice can practically be dispensed with for the operation of a refrigerating car, and in this aspect my improvement will be useful to the extent of saving all of the difference in the costs between the great expense of ice and the comparatively small expense of running this apparatus.

I claim—

1. The process of refrigerating the air in a chill room which consists of compressing air within one or more compressed air compartments, compressing a volatile fluid in a compressor driven by the compressed air, cooling the compressed fluid, and expanding the same under a partial vacuum in a refrigerator, substantially as described.
2. The process of refrigerating the air of a chill room, which consists of compressing air within one or more compressed air compartments, compressing chloride of ethyl in a compressor driven by the compressed air, cooling the compressed chloride of ethyl, and expanding the same under a partial vacuum, substantially as described.
3. The method or process, substantially as described, of cooling air, which consists in compressing chloride of ethyl, condensing it by cooling, volatilizing it in a chamber of sufficient sectional area wherein to deposit its crystals without obstructing the passage of the gas, and conducting the volatilized fluid through constricted passages adjoining which the air circulates.
4. The method of driving an engine located upon a car, which consists in compressing and storing a gas by means of a pump operated by the motion of the car, and utilizing the gas for operating the engine, substantially as described.
5. The method of cooling a refrigerator located upon a car, which consists in compressing and storing a gas by means of a pump operated by the motion of the car, and utilizing this gas for operating an engine to compress a volatile fluid which is first compressed, then passed through a condenser where it is cooled, and then expanded in the refrigerator, substantially as described.
6. The herein described method of cooling the air in a chill room which employs two bodies of gas, the first of which is compressed and employed to drive the engine in which the second is compressed, and the second after being compressed by the power of the first being cooled in a condenser, and then being expanded to produce the requisite cold in the refrigerator.
7. The herein described method of cooling the air of a chill room which employs two bodies of gas, one of which, as air, is less easily compressed than the other, as chloride of ethyl, the first of these bodies of gas being compressed and employed to drive the engine in which the second body of gas is compressed, and the second body of gas being expanded in the refrigerator for producing the requisite cold therein.
8. The combination, substantially as described, with a railroad car of an air compressor located on the car, and operated by the motion thereof, and one or more compressed air storage compartments, wherein compressed air may be stored, to be used for driving apparatus located on the car.
9. A refrigerator car divided into a compartment for containing the articles to be refrigerated, a compartment containing the air-compressing and gas-compressing engines, a compartment containing the condenser, and a compartment containing the refrigerator, the last three being all arranged in a group and combined, substantially as described.
10. In combination, the chill room containing inlet and outlet air openings, the air-circulating fan-blower, the refrigerator arranged in the part of the current of air produced by the fan-blower, the condenser, the gas compressor, operated by compressed air, the compressed air storage compartment, and the air compressor, substantially as described.
11. In combination the mechanism, substantially as described, whereby the prime gas-compressing pump is operated by the motion of the car, the prime gas-compressing pump, the storage compartment, the pump wherein the gas used for cooling is compressed, the condenser, the refrigerator, and the chill room.
12. In combination with the gas compressor and condenser, the refrigerator constructed with the horizontal pipe or pipes 31, and the branch pipes 32, leading upward therefrom, whereby an extended surface is exposed for the escape of the gas from the liquified fluid, as set forth.
13. The combination, substantially as described, with a railroad car of a condenser, a refrigerator, and a gas-compressing engine, connected with one or more compressed air storage compartments, wherein is stored a body of compressed air for driving the gas-compressing engine, the body of compressed air having no communication with the gas which is compressed.
14. In combination with the chill room and the gas-compressing engine, a pipe leading from the expansion cylinder of said engine to said chill room, whereby the expanded air from the cylinder is conveyed to said chill room to supply leakage and prevent the entrance of dust or warm air into the chill room, substantially as described.
15. In combination with the car, the refrigerator and condenser arranged relatively to each other, substantially as described, so that the bottom of the condenser is above the level of the bottom of the refrigerator, whereby the liquified gas will be prevented from collecting in any portion of the apparatus below the refrigerator.
16. In combination with the gas-compressing engine and the passage or pipe for conveying the compressed gas to the refrigerator, the said refrigerator containing gas passages, in contact with the exterior of which the air of the chill room circulates, and provided with a passage or passages, substantially as described, of large area relatively to the supply passage, wherein the gas may expand and the obstruction of its passage avoided.
17. In combination, the air-compressing pump, the gas-compressing engine, and suitable passages connecting the suction-pipe of the air-compressing pump with the escape pipe of the expansion cylinder

Improvements in Refrigerator Cars.

- cylinder of the gas-compressing engine, and other passages connecting the escape pipe of the air-compressing pump with the induction pipe of the expansion cylinder of the gas-compressing engine, whereby the same supply of air is used over and over again.
18. In combination with the air-compressing engine located upon a car, the casing surrounding the cylinder of the same and forming an air-jacket, which is connected by air-ducts with the exterior atmosphere, whereby the motion of the car causes a circulation of air within said casing and around the compression cylinder, substantially as described.
 19. In combination with the compression cylinder, the absorbent covering f^1 and the water tank from which water is supplied to the covering through the pipe f^1 , substantially as described.
 20. In combination with the compression cylinder, the absorbent covering f^1 , the casing f , a suitable pipe for supplying the covering with moisture, and a suitable air-duct for causing a current of air to circulate within the casing, substantially as described.
 21. In combination with the car body, the condenser located upon the car for cooling the compressed fluid, the water tank located at the top of the car, and a suitable pipe for conveying the water from the tank and distributing it upon the condenser, substantially as described.
 22. In combination with the condenser arranged within an enclosure or casing upon a car, inlet and outlet air openings connected with said enclosure, substantially as described, whereby the motion of the car causes a current of air to flow in contact with said condenser, substantially as described.
 23. In combination with the condenser arranged upon a car, an absorbent covering in contact with said condenser, water-pipes for conveying water from a suitable source of supply to said absorbent covering, and air-ducts arranged substantially as described, whereby the motion of the car induces a current of air to pass in contact with said covering.
 24. In combination with the condenser and the gas compressing engine located on a car, a pipe leading from the expansion cylinder of the engine to the condenser, whereby the cooled expanded air is brought into contact with the condenser to cool the same, substantially as described.
 25. In combination with a railway car, the air compressor, the compressed air storage compartment, the gas compressor, the condenser, the refrigerator, and the chill room, all arranged and located on the car substantially as described.
 26. In combination with the cylinders 16 and 17, the compartment 22, connected with the cylinder 17, and surrounding the cylinder 16, substantially as described.
 27. In combination with the cylinders 16 and 17, the air passages 20 and 21 connected with the cylinder 16, and arranged with reference to the cylinder 17, substantially as described.
 28. In combination with the air cylinder 16, the gas-compressing cylinder 17, constructed shorter than the cylinder 16, the pistons of the two cylinders being connected by suitable mechanism, whereby the expansion of the air in cylinder 16 compresses the gas in cylinder 17, as and for the purpose set forth.
 29. In combination, the pulley connected with the axle of the car, the belt connecting said pulley with the air-compressor, the air-compressor, and the compressed air storage compartment, substantially as described.
 30. In combination, the pulley connected with the axle of the car, the belt whereby the motion of said pulley is communicated to apparatus on the car, reciprocating friction rollers bearing against said belt, and mechanism substantially as described, whereby said rollers are caused to approach each other and exert a yielding pressure upon said belt for the purpose set forth.
 31. In combination, the pulley connected with the car axle, the pulley whereby the motion of said belt is communicated to apparatus on the car, a reciprocating friction roller bearing against said belt, and adjustable bearings, whereby said roller may automatically incline to adjust itself to the varying inclinations of the belt, substantially as described.
 32. In combination with the pulley upon the car axle, the casing 15 secured to the spring timber m of the truck, substantially as described.
 33. In combination with the pulley upon the car axle, the casing enclosing the same, and the flexible apron n connecting with the car body, substantially as described.
 34. In combination with the pulley connected with the car axle and the belt connecting the same with apparatus located on the car, the friction rollers 12 12, mounted on the guide 13, and the spring whereby the rollers are caused to exert a yielding pressure against the belt, substantially as described.
 35. In combination with the pulley connected with the car axle and the belt for driving apparatus on the car from the same, a friction roller arranged to be pressed against the belt by the yielding pressure of a spring and the weighted lever 14, to which the spring is connected, whereby the belt can be released from the pressure of the spring by raising the lever whenever it is desired to stop the operation of the apparatus.
 36. In combination, the chamber surrounding the condenser, the air-compressing pump having its suction-pipe connected with said chamber, and the expansion cylinder of the gas-compressing engine having its escape pipe also connected with said chamber, whereby the air is taken from one part of said chamber, and after being compressed and expanded is delivered into another part of said chamber, substantially as described.
 37. In combination with the compressing pump, operated substantially as described by the motion of the car, the suction-pipe provided with the cut-off valve j , whereby the compressing pump may cease compressing when the pressure produced has reached a predetermined intensity, substantially as described.
 38. In combination with the gas-compressing engine and supply-pipe leading thereto, the pressure regulating valve k , and the reservoir l , interposed between the valve k and the gas-compressing engine, substantially as described.

Improvements in Refrigerator Cars.

39. The combination of the fan-blower with the compressing apparatus and suitable connections whereby the operation of the compressing apparatus operates the fan-blower, substantially as described.

In witness whereof, I, the said Cassius Clay Palmer, have hereto set my hand and seal, this twenty-ninth day of November, one thousand eight hundred and eighty-three.

CASSIUS CLAY PALMER

Witnesses—

W. F. HAPGOOD.

D. H. DRISCOLL.

This is the specification referred to in the annexed Letters of Registration granted to Cassius Clay Palmer, this seventeenth day of April, A.D. 1884.

AUGUSTUS LOFTUS

REPORT.

Sir,

Sydney, 7 February, 1884

In the matter of the application of Mr. C. C. Palmer for Letters of Registration for "Improvements in Refrigerating Cars," which has been referred to us, we have the honor to report as follows:— Having examined the specification and drawings submitted, we see no objection to the issue of Letters of Registration for the apparatus as a whole, substantially as figured and described; but when we consider the claims in detail, reaching the extraordinary number of 39, we find that some are for well-known contrivances which could not be separately protected—as, for example, claim 24, which is merely for a pipe leading from one part to another; but inasmuch as such items are only claimed in combination with others, and as necessary components of the complete refrigerating apparatus, we do not think it necessary to recommend that any of these claims should be expunged, although in our view quite unnecessary.

We have, &c.,

J. SMITH.

A. LEIBIUS.

The Under Secretary of Justice.

[Drawings—three sheets.]

Fig. 1.

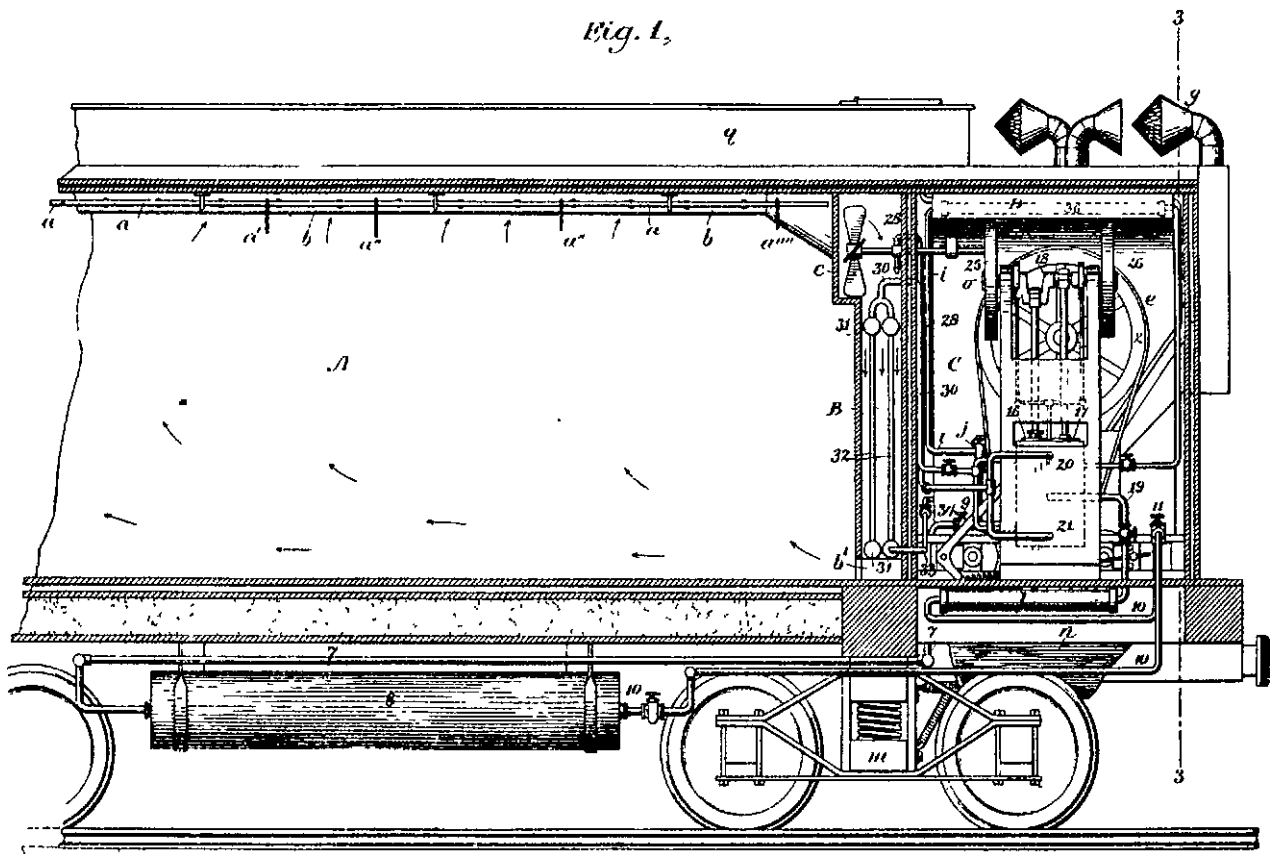


Fig. 2.

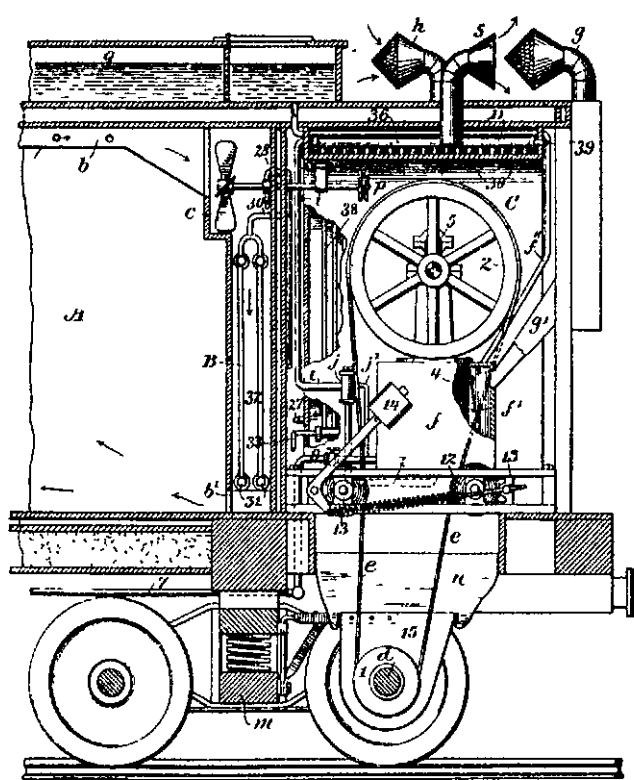
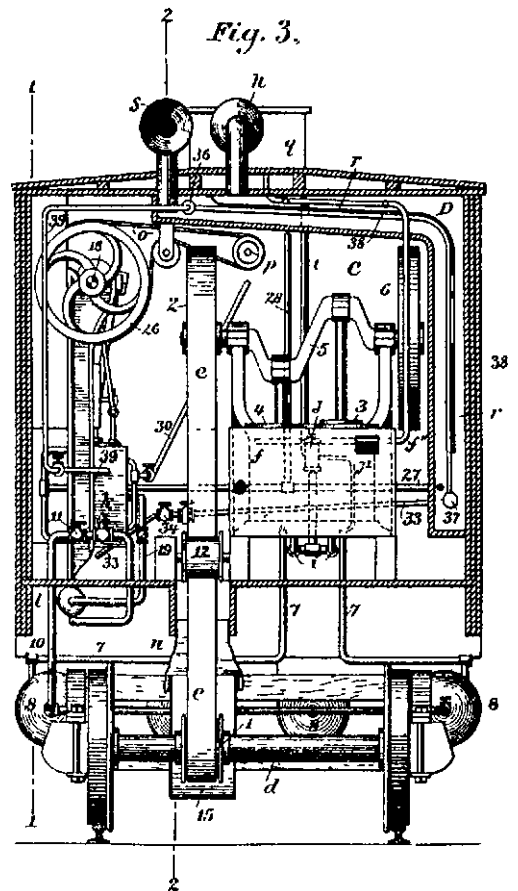


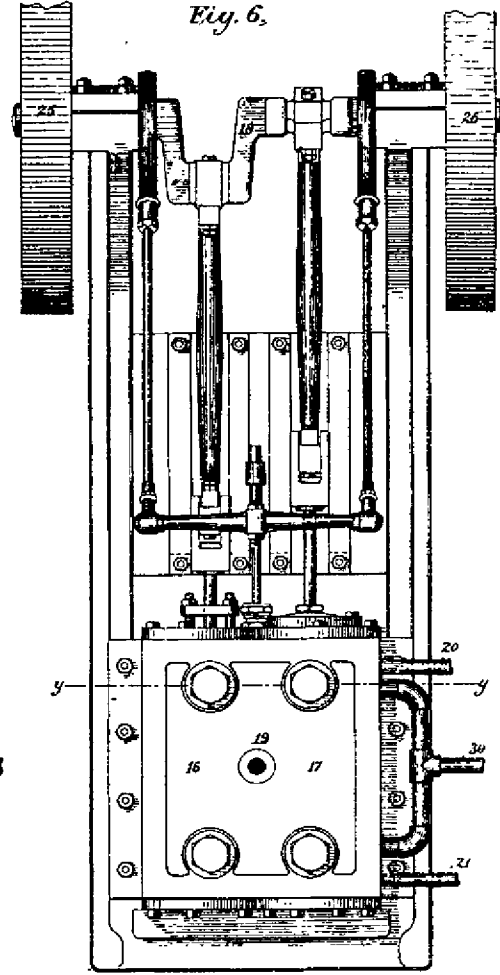
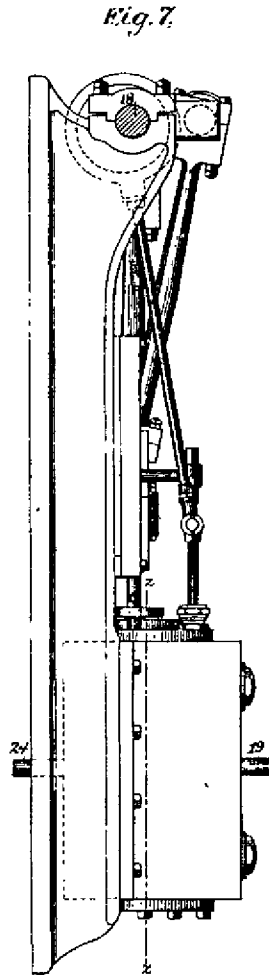
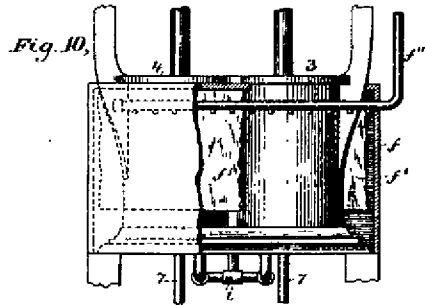
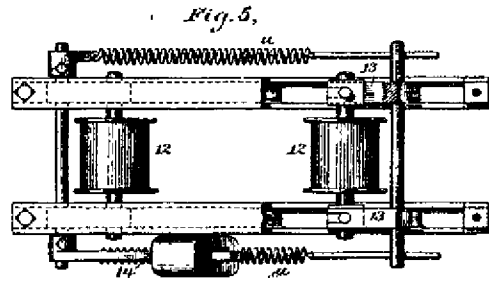
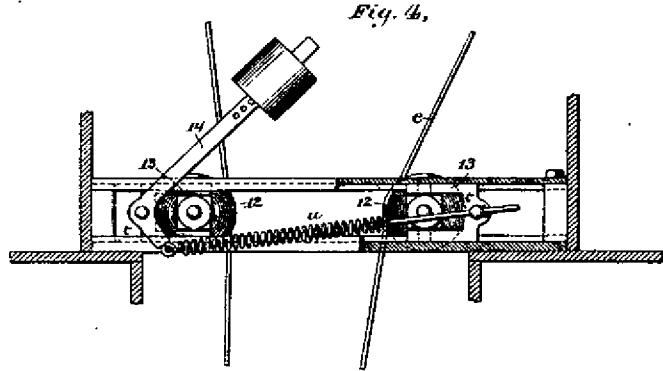
Fig. 3.



(Sig: 245~)

This is the Sheet of Drawings marked A referred to in the annexed Letters of Registration, granted to Cassius Clay Palmer, this seven-teenth day of April, A. D., 1884.

Augustus Loftus.

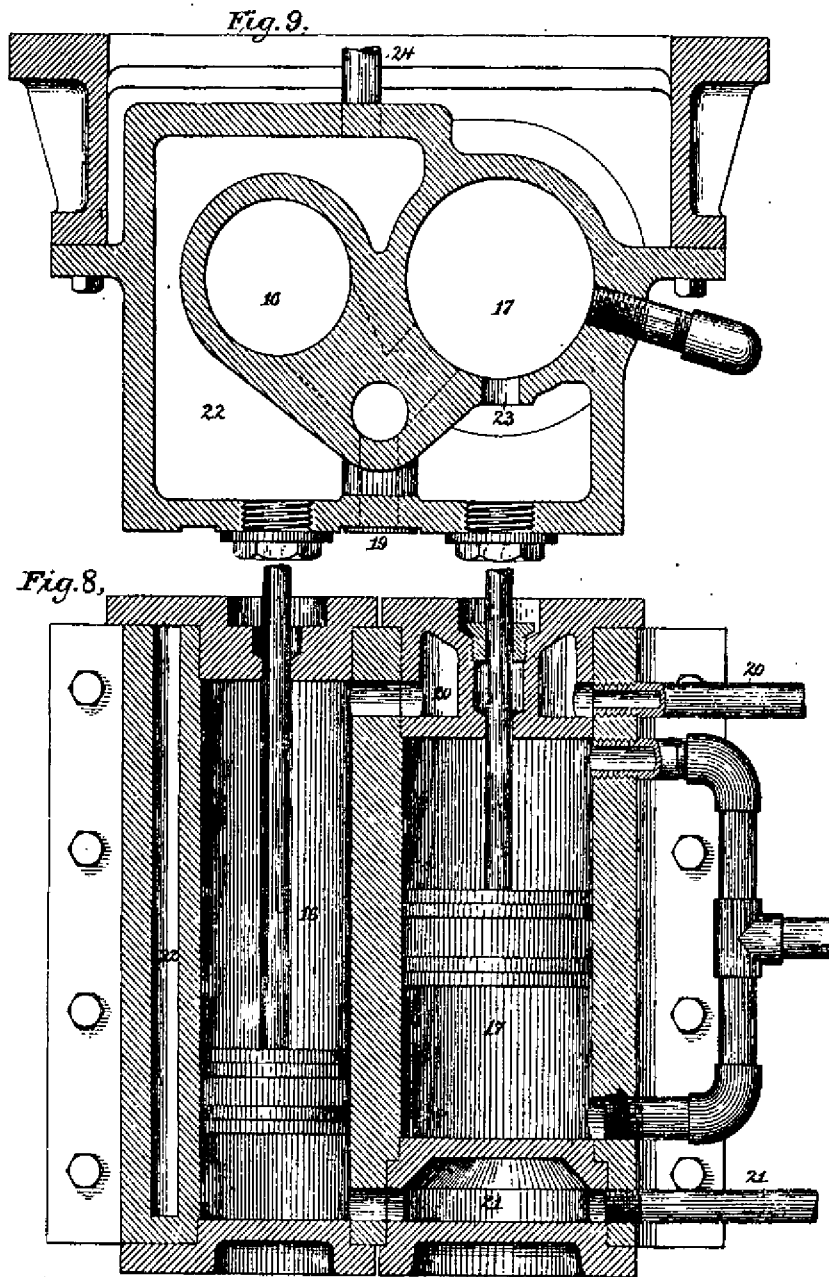


(Sig: 245~)

*This is the Sheet of Drawings marked B preferred to in the annexed
 Letters of Registration, granted to Cassius Clay Palmer; this seven-
 -teenth day of April, A.D., 1884. Augustus Loftus.*

C

1414



(Sig: 245~)

This is the Sheet of Drawings marked C, referred to in the annexed Letters of Registration, granted to Cassius Clay Palmer, this seventeenth day of April, A.D., 1884. **Augustus Loftus.**



A.D. 1884, 16th April. No. 1415.

IMPROVEMENTS IN APPARATUS FOR REVERSING THE MOTION OF STEAM
AND OTHER ENGINES.

LETTERS OF REGISTRATION to Ernest Boutard, for Improvements in apparatus
for reversing the motion of Steam and other Engines.

[Registered on the 18th day of April, 1884, in pursuance of the Act 16 Vic. No. 24.]

BY HIS EXCELLENCY THE RIGHT HONORABLE SIR AUGUSTUS WILLIAM FREDERICK SPENCER LOFTUS
(commonly called LORD AUGUSTUS LOFTUS), Knight Grand Cross of the Most Honorable Order of
the Bath, a Member of Her Majesty's Most Honorable Privy Council, Governor and Commander-in-
Chief of the Colony of New South Wales and its Dependencies.

TO ALL TO WHOM THESE PRESENTS SHALL COME, greeting :

WHEREAS ERNEST BOUTARD, of Leiston, in the county of Suffolk, England, mechanical draftsman, hath by his Petition humbly represented to me that he is the author or designer of a certain invention or improvement in manufactures, that is to say, of an invention entitled "Improvements in Apparatus for reversing the motion of Steam and other Engines," which is more particularly described in the specification and the sheet of drawings which are herunto annexed; and that he, the said Petitioner, hath deposited with the Honorable the Treasurer of the said Colony of New South Wales the sum of Twenty Pounds sterling, for defraying the expense of granting these Letters of Registration, as required by the Act of Council, sixteenth Victoria, number twenty-four; and hath humbly prayed that I would be pleased to grant Letters of Registration, whereby the exclusive enjoyment and advantage of the said invention or improvement might be secured to him for a period of fourteen years: And I, being willing to give encouragement to all inventions and improvements in the arts or manufactures which may be for the public good, and having received a report favourable to the prayer of the said Petition, from competent persons appointed by me to examine and consider the matters stated therein and to report thereon for my information, am pleased, with the advice of the Executive Council, and in exercise of the power and authority given to me by the said Act of Council, to grant, and do by these Letters of Registration grant unto the said Ernest Boutard, his executors, administrators, and assigns, the exclusive enjoyment and advantage of the said invention or improvement, for and during the term of fourteen years from the date hereof; to have, hold, and exercise unto the said Ernest Boutard, his executors, administrators, and assigns, the exclusive enjoyment and advantage thereof, for and during and unto the full end and term of fourteen years from the date of these presents next and immediately ensuing, and fully to be complete and ended: Provided always, that if the said Ernest Boutard shall not, within three days after the granting of these Letters of Registration, register the same in the proper office in the Supreme Court, at Sydney, in the said Colony of New South Wales, then these Letters of Registration, and all advantages whatsoever hereby granted, shall cease and become void.

In witness whereof, I have herunto set my sign manual, and have caused the present Letters of Registration to be sealed with the seal of the said Colony of New South Wales, at Government House, Sydney, in New South Wales, this sixteenth day of April, in the year of our Lord one thousand eight hundred and eighty-four.

[L.s.]

AUGUSTUS LOFTUS.

Improvements in apparatus for reversing the motion of Steam and other Engines.

SPECIFICATION of ERNEST BOUTARD, of Leiston, in the county of Suffolk, mechanical draftsman, for an invention entitled "Improvements in apparatus for reversing the motion of Steam and other Engines."

THE object of this invention is to provide a means for reversing the motion of portable, traction, marine, or other engines, whilst running, and without the use of duplicate eccentrics, link motion, or variable expansion gear.

This object is attained by means of a clutch arrangement, by which the ordinary eccentric driving the distributing valve may be disengaged at pleasure from the crank shaft and again connected therewith whilst the engine is still running, when the momentum of the crank shaft shall have carried the crank pin forward by so much of a single revolution as may be necessary in order to afford to the eccentric the requisite angle in relation to the crank pin for the reversal of the motion.

The means by which the re-engaging of the clutch is effected at the right moment consist in forming on or applying to one part a member of the clutch, a tooth, or projection, which, when the clutch is disengaged from the eccentric, is caused to act as a fixed stop, and is brought in contact with a tooth or projection on the other part or member of the clutch, when the momentum of the fly-wheel or crank shaft shall have carried the crank pin forward by so much of a single revolution as may be necessary in order to give to the eccentric the requisite angle in relation to the crank pin for the reversal of the engine.

Or, if it should be desired to arrange the reversal of the motion of the engine when it is not in action, the fly-wheel or crank shaft may be turned the required distance by hand, the eccentric being disengaged therefrom until the moment for re-engagement is determined by the contact of the said teeth or projections upon the clutch; or this operation may be performed by causing a partial revolution of the eccentric, instead of turning the fly-wheel or crank shaft.

Having thus stated the nature of the said invention, I will proceed to describe more particularly in what manner the same is to be performed by the aid of the accompanying drawings, in which are represented adaptations of the said clutch arrangement to a portable engine.

DESCRIPTION OF THE DRAWINGS.

FIGURE 1 shows the parts of apparatus in plan or horizontal view; figures 2 and 3 show portions of the same in elevation. It is to be observed that the eccentric *b* which works the distributing valve is mounted loosely on the crank shaft *a*, and is driven by the tapered pin *f* which is bolted to it, and is caused to pass through one or other of the two holes A or B formed in the disc *c*, accordingly as it may be desired to run the engine in one direction or the other.

By this means a connection is formed between the eccentric *b* and the disc *c*, that is to say, between the two members of the clutch.

The disc *c* is capable of sliding on a feather *d* on the crank shaft *a*, and is moved to the right or left as required by means of the lever *h*, working on the fulcrum *i*. For the convenience of the driver of the engine this lever is generally extended to the fire-box end of the boiler, or it may be extended or carried to any other situation required.

When it is desired to reverse the motion of the engine the disc *c* is slidden along the crank shaft *a*, so far as may be necessary, in order to disengage the taper pin *f* of the eccentric from the hole A or B in the disc. The eccentric and distributing valve then cease to move, and the disc is carried forward by the momentum of the crank shaft over so much of a single revolution as is required for the reversal of the engine, when the pin *f* of the eccentric is brought opposite to the other hole B (or A, as the case may be), and is prevented from going further by its contact with the projecting plate *e* upon the disc. The disc is then again slidden in the direction of the eccentric, so as to engage the driving pin *f* in the corresponding hole B (or A) in this disc, and the motion of the engine becomes thereby immediately and easily reversed.

Figure 4 shows a modified arrangement by which a precisely similar effect is produced. In this case the eccentric *b* sits loose upon a prolongation of the boss of the disc *c*, which is slidden as required upon the feather *d* on the crank shaft *a*, as under the previous arrangement.

Figure 5 shows another modification in which the eccentric *b* sits upon a feather *d* on a movable boss *g*, which sits loose upon the crank shaft and receives rotary motion by means of the clutch K, which is keyed fast upon the crank shaft, the movable boss *g* being slidden by means of a forked lever, as previously described, to the right or left upon the crank shaft, and through the eccentric, in order to effect this connection from and re-engagement with the clutch K, as may be required.

In all the above arrangements it will be seen that the disconnection of the eccentric from the crank shaft and its re-engagement therewith are respectively effected as required by moving one member of the clutch out of or into connection with the other member thereof, and that there is on one member a projection which by being brought in contact with a projection on the other member determines the proper moment for the re-engagement, in the manner substantially as described.

If it should be desired to arrange for the reversal of the motion of the engine when not in action, the fly-wheel or crank shaft may be turned the required distance by hand, the eccentric being disengaged therefrom until the moment for re-engagement is determined by the contact of the said projections upon the eccentric and the disc forming the two members of the clutch; or the operation may be performed by causing a partial revolution of the eccentric, instead of turning the fly-wheel or the crank shaft.

Having thus described the nature of the said invention, and in what manner the same is to be performed, I would remark that the parts constituting the clutch as represented and described may be varied in form and arrangement: Provided that in combination they are adapted to utilize the momentum of the crank shaft of a steam or other engine when in motion, in order to carry forward the fixed part or member of the clutch (after the eccentric which actuates the distributing valve of the engine is disengaged therefrom) by so much of a single revolution as may be necessary for the reversal of the engine, and also to determine the proper moment for re-engagement by the contact of teeth, pins, projections, plates, or their equivalent, upon the mechanism forming the said clutch, which imparts rotation to the eccentric actuating the distributing valve of a steam or other engine, and I claim as of my invention—

Reversing

Improvements in apparatus for reversing the motion of Steam and other Engines.

Reversing gear for a steam or other engine, consisting of a clutch arrangement in which a projection on one part or member of the clutch acting in combination with a suitably arranged projection on the other part or member thereof serves to determine the right moment for and to facilitate the re-engagement of the excentric (which actuates the distributing valve) with the crank shaft, as required, after its disengagement therefrom, thereby reversing the motion of the engine, in the manner substantially as hereinbefore described.

In witness whereof, I, the said Ernest Boutard, have hereto set my hand and seal, this eighth day of January, one thousand eight hundred and eighty-four.

ERNEST BOUTARD.

This is the specification referred to in the annexed Letters of Registration granted to Ernest Boutard, this 16th day of April, A.D. 1884.

AUGUSTUS LOFTUS.

REPORT.

Sir,

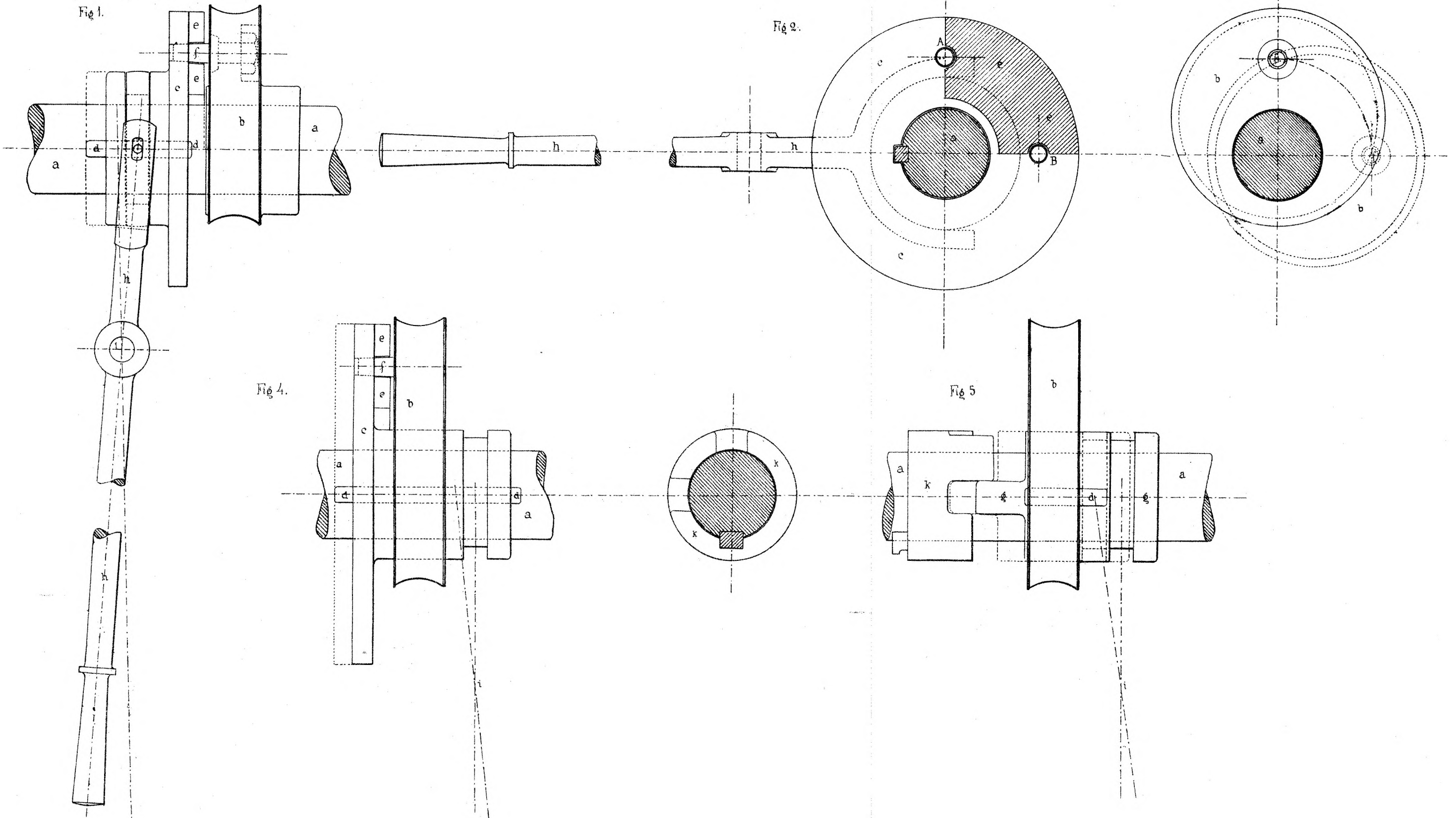
In reply to your letter of the 25th ultimo, we have the honor to report that we have examined Mr. Ernest Boutard's application for Letters of Registration for an invention entitled "Improvements in apparatus for reversing the motion of Steam and other Engines," also the specification and drawings therewith, and see no reason why his application should not be granted.

Sydney, 4 March, 1884.

We have, &c.,
FRANCIS HIXSON.
H. BRODERICK.

The Under Secretary of Justice.

[Drawings—one sheet.]



This is the Sheet of Drawings referred to in the annexed Letters of Registration, granted to Ernest Boutard, this sixteenth day of April, A.D., 1884.

(Sig: 245~)

Augustus Loftus.



A.D. 1884, 16th April. No. 1416.

IMPROVEMENTS IN MECHANICAL TELEPHONE APPARATUS.

LETTERS OF REGISTRATION to George Fred. Shaver, for Improvements in Mechanical Telephone Apparatus, chiefly designed for a central office or exchange system.

[Registered on the 18th day of April, 1884, in pursuance of the Act 16 Vic. No. 24.]

BY HIS EXCELLENCY THE RIGHT HONORABLE SIR AUGUSTUS WILLIAM FREDERICK SPENCER LOFTUS (commonly called LORD AUGUSTUS LOFTUS), Knight Grand Cross of the Most Honorable Order of the Bath, a Member of Her Majesty's Most Honorable Privy Council, Governor and Commander-in-Chief of the Colony of New South Wales and its Dependencies.

TO ALL TO WHOM THESE PRESENTS SHALL COME, greeting :

WHEREAS GEORGE FRED. SHAVER, of Eyrie, Pennsylvania, United States of America, hath by his Petition humbly represented to me that he is the author or designer of a certain invention or improvement in manufactures, that is to say, of an invention entitled "Improvements in Mechanical Telephone Apparatus, chiefly designed for a central office or exchange system," which is more particularly described in the specification and the sheet of drawings which are hereunto annexed; and that he, the said Petitioner, hath deposited with the Honorable the Treasurer of the said Colony of New South Wales the sum of Twenty Pounds sterling, for defraying the expense of granting these Letters of Registration, as required by the Act of Council, sixteenth Victoria, number twenty-four; and hath humbly prayed that I would be pleased to grant Letters of Registration, whereby the exclusive enjoyment and advantage of the said invention or improvement might be secured to him for a period of fourteen years: And I, being willing to give encouragement to all inventions and improvements in the arts or manufactures which may be for the public good, and having received a report favourable to the prayer of the said Petition, from competent persons appointed by me to examine and consider the matters stated therein and to report thereon for my information, am pleased, with the advice of the Executive Council, and in exercise of the power and authority given to me by the said Act of Council, to grant, and do by these Letters of Registration grant unto the said George Fred. Shaver, his executors, administrators, and assigns, the exclusive enjoyment and advantage of the said invention or improvement, for and during the term of fourteen years from the date hereof; to have, hold, and exercise unto the said George Fred. Shaver, his executors, administrators, and assigns, the exclusive enjoyment and advantage thereof, for and during and unto the full end and term of fourteen years from the date of these presents next and immediately ensuing, and fully to be complete and ended: Provided always, that if the said George Fred. Shaver shall not, within three days after the granting of these Letters of Registration, register the same in the proper office in the Supreme Court, at Sydney, in the said Colony of New South Wales, then these Letters of Registration, and all advantages whatsoever hereby granted, shall cease and become void.

In witness whereof, I have hereunto set my sign manual, and have caused the present Letters of Registration to be sealed with the seal of the said Colony of New South Wales, at Government House, Sydney, in New South Wales, this sixteenth day of April, in the year of our Lord one thousand eight hundred and eighty-four.

[L.S.]

AUGUSTUS LOFTUS.

Improvements in Mechanical Telephone Apparatus.

SPECIFICATION of GEORGE FRED. SHAVER, of Erie, Pennsylvania, United States of America, for an invention entitled "Improvements in Mechanical Telephone Apparatus, chiefly designed for a central office or exchange system."

THIS invention relates to mechanical telephones of the kind in which two vibratory diaphragms are connected by a line wire under a certain degree of tension. For such telephones it is necessary to support and maintain the tension of the line wires in such a manner as not to interfere with their power of conducting sound pulses, to construct the diaphragms in such a manner as to receive and transmit the pulses freely and effectively, and to provide means of readily connecting and disconnecting line wires in a central office or exchange from which they radiate. I will describe this invention which has these objects in view, referring to the accompanying drawings.

Fig. 1 is a front view, and fig. 2 is a section showing how the diaphragm K is mounted in a case R and connected to a line wire X. It will be seen that the line-wire branches out into a number of diagonal stretchers *k*, which are connected by ties *p* to the circumference. The diaphragm may be circular, as shown, or it may be square or polygonal. When the diaphragm is in a central office or place where it should be capable of being connected to wires in various directions, I arrange it as shown in front view by fig. 3, and in longitudinal section by fig. 4. The telephone L, that is to say, the diaphragm with its frame, is placed within a cylinder N, within which it can be slid to and fro by means of knobs *lz* projecting through slits cut along the opposite sides of the cylinder N, with rack teeth, between any two of which the pins of *lz* can be engaged. The cylinder N has a rectangular end O fitting into grooves in the framing C¹, and the telephone can be slid to and fro transversely so as to bring its wire X in position to connect with any wire which is hooked into one of the notches *h* of a rim C. Where the line-wire has to pass through a wall or partition, I attach it as shown in the perspective view fig. 5, to a diaphragm D, which is stretched in a ring frame fixed in the wall or partition. This diaphragm may be made of strong canvas with a washer *w* fixed on the wire A close against the diaphragm. Fig. 5 indicates the branching of one wire A into two, A and B. Figs. 6 and 7 show arrangements for stretching the line-wire A so as to allow for alterations of its length due to changes of temperature. For this purpose a lever I, which may be of bell crank form I¹, is mounted on a post P¹ and suspends from one of its arms a weight *a*. The other arm is connected to a bent or flexible bar H¹ or H² which has loops of cotton or other cord engaging the wire A. The bent bars H¹ or H² prevent the line-wire from bending at a sharp angle. Fig. 8 shows in perspective arrangements for forming connections of the line-wires in a central office or exchange. Round a central post P are fixed three annular frames C, C¹, and C², a section through which is shown in fig. 4. These are large enough to give room for the attendant to stand or sit within them, having under his command the various wires, which when loose are hooked into notches of the rings C and C², and a set of telephones which can be slid round the ring C¹. He has also within reach a set of horizontal bars M which can be slid up or down or turned round the post P, and fixed in position thereon by setting screws. On each of the bars M is fitted, free to slide and turn, a small windlass, which is shown to an enlarged scale in perspective at fig. 9. It consists of a sleeve E, which can be fixed by a setting screw T on the bar M, with brackets *e* projecting from it to support a barrel that can be turned by a handle S. Holes are provided in one of the brackets *e* to receive a stud *s* projecting from the handle. To the cord of the windlass is attached one of the flexible bars H, having looped to it a wire F, by which any two of the line wires are connected. The line wires AA¹, &c., pass through the diaphragms DD¹, &c., and any two of them are connected as A to A¹, A² to A³, while those that are not connected are hooked on to the ring C² as A¹. The branch wires BB¹, &c., from the several diaphragms DD¹, &c., are either loose hooked on to the ring C, as B, B¹ and B², or may be connected as B² to one of the telephones N in the ring C¹.

When the attendant desires to communicate with a station such as that to which the wire A² leads, he connects the branch B² to the wire *n* of one of his telephones in the ring C¹, and having moved back the telephone within its cylindrical case N to give B² the desired tension, he taps on the ring R, showing the distant person that he is ready. He then, if desired, connects A² to some other wire, as A³, and gives the proper tension by the windlass S. When a distant person desires to communicate with the central attendant he has only to tap on the rim of his telephone, and this signal is heard by the attendant proceeding from one of the diaphragms D.

Having thus described the nature of this invention, and in what manner the same is to be performed, I would have it understood that I make no claim to mechanical telephones consisting of vibratory diaphragms connected by stretched cords or wires, nor do I claim any mode of connecting or stretching the wires of such telephones, other than those mentioned in the following claiming clauses, but I claim—

- First—Connecting the line wire to the diaphragm K by diagonal stretchers *k* and ties *p*, substantially as described with reference to figs. 1 and 2.
- Second—Mounting the telephone L for use in a central office, to slide in a case N, movable in the ring C¹, substantially as described with reference to figs. 3 and 4.
- Third—For stretching the telephone wires A, the combination of the loaded lever I or I¹, and the bent bar H¹ or H² with loops attached to the wire, substantially as described with reference to figs. 6 and 7.
- Fourth—In a central telephone office or exchange the combination of a central post P, adjustable bars M, windlass S thereon, and flexible bars H, with their attachments, substantially as described with reference to figs. 8 and 9.
- Fifth—In a central telephone office or exchange, in combination with a number of line wires A, the wall diaphragms D, the branch wires B, and the notched rings C and C², substantially as described with reference to fig. 8.

In witness whereof, I, the said George Fred. Shaver have hereto set my hand and seal, this seventh day of February, one thousand eight hundred and eighty-four.

Witness—

W. S. BAYSTON,
Patent Law Clerk, Melbourne.

G. F. SHAVER.
(By his Agent, EDWD. WATERS).

This is the specification referred to in the annexed Letters of Registration granted to George Fred. Shaver, this sixteenth day of April, A.D. 1884.

AUGUSTUS LOFTUS.
REPORT.

Improvements in Mechanical Telephone Apparatus.

REPORT.

Sir,

Sydney, 25 February, 1884.

We do ourselves the honor to report, in reply to your blank cover of the 13th instant, No. 1,762, transmitting George Fred. Shaver's Petition for the Registration of "Improvements in Mechanical Telephone Apparatus, chiefly designed for a central office or exchange system," that we are of opinion the prayer of the Petitioner may be granted in terms of his specification, drawings, and claim.

We have, &c.,
E. C. CRACKNELL,
GOTHER K. MANN.

The Under Secretary of Justice.

[Drawings—one sheet.]

No. 1417.

[Assignment of No. 1038. See Letters of Registration for 1882, page 27.]

No. 1418.

[Assignment of No. 1038. See Letters of Registration for 1882, page 43.]

No. 1419.

[Assignment of No. 1038. See Letters of Registration for 1882, page 43.]

No. 1420.

[Assignment of No. 1038. See Letters of Registration for 1882, page 27.]

Fig: 8

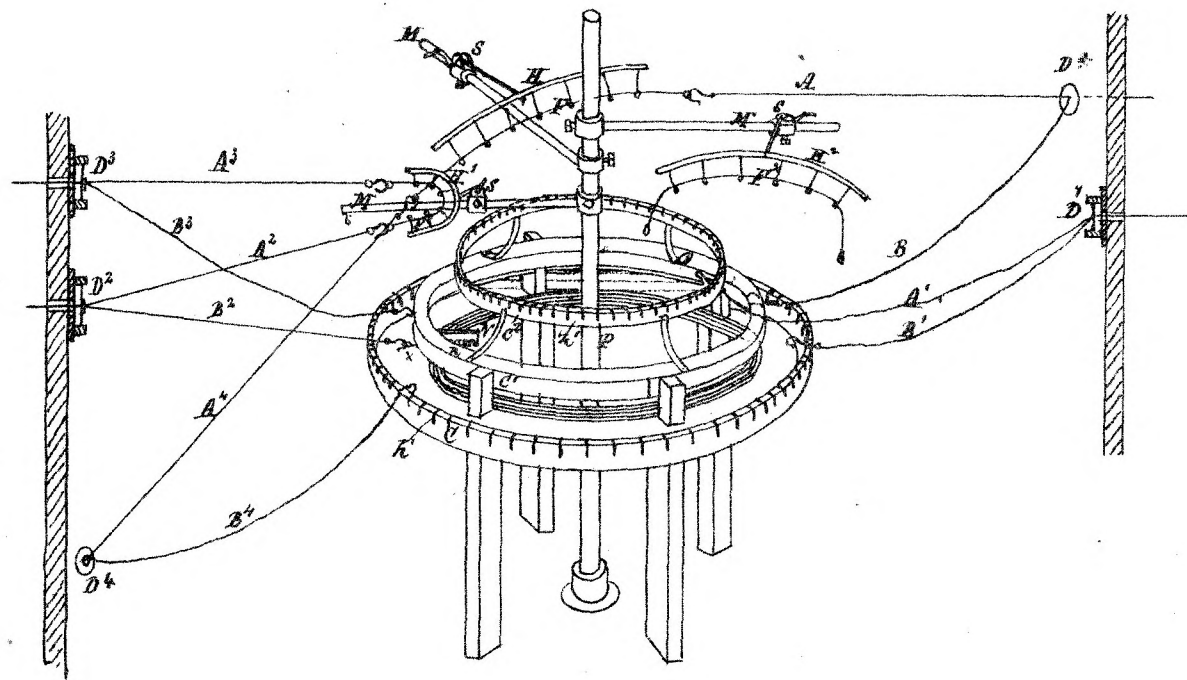


Fig: 6

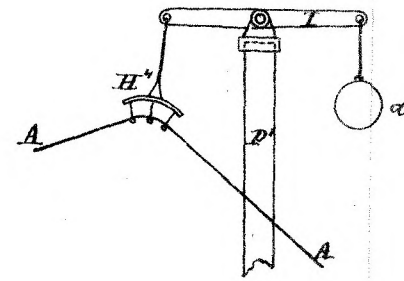


Fig: 7

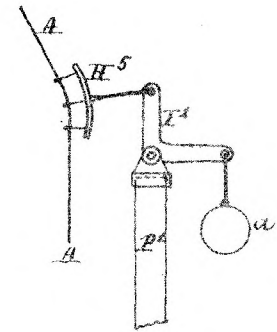


Fig: 5

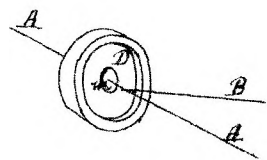


Fig: 9

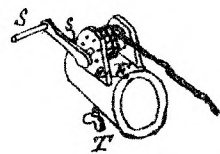


Fig: 1

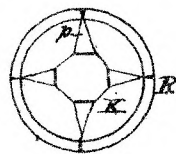


Fig: 2

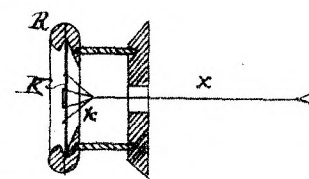
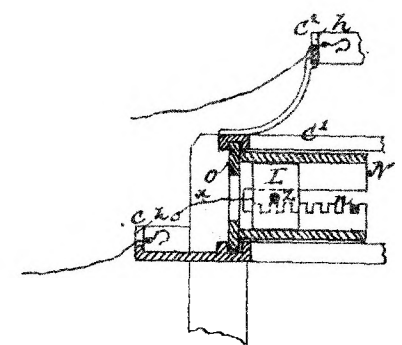


Fig: 3



Fig: 4



This is the Sheet of Drawings referred to in the annexed Letters of Registration, granted to George Fred Shaver; this sixteenth day of April, A. D., 1884.

Augustus Loftus.



A.D. 1884, 29th April. No. 1421.

IMPROVED METHOD FOR EXTRACTING METALS FROM THEIR ORES.

LETTERS OF REGISTRATION to Thomas Rowland Jordan and John Needham Longden, for an improved method or process and apparatus for extracting metals from their ores and concentrating heavy materials.

[Registered on the 30th day of April, 1884, in pursuance of the Act 16 Vic. No. 24.]

BY HIS EXCELLENCY THE RIGHT HONORABLE SIR AUGUSTUS WILLIAM FREDERICK SPENCER LOFTUS (commonly called LORD AUGUSTUS LOFTUS), Knight Grand Cross of the Most Honorable Order of the Bath, a Member of Her Majesty's Most Honorable Privy Council, Governor and Commander-in-Chief of the Colony of New South Wales and its Dependencies.

TO ALL TO WHOM THESE PRESENTS SHALL COME, greeting :

WHEREAS THOMAS ROWLAND JORDAN, of Gracechurch-street, in the city of London, England, engineer, and JOHN NEEDHAM LONGDEN, of Charters Towers, Queensland, but now residing in London, England, mining engineer, have by their Petition humbly represented to me that they are the authors or designers of a certain invention or improvement in manufactures, that is to say, of an invention entitled " An improved method or process and apparatus for extracting metals from their ores, and concentrating heavy materials," which is more particularly described in the specification and the sheet of drawing which are hereunto annexed; and that they, the said Petitioners, have deposited with the Honorable the Treasurer of the said Colony of New South Wales the sum of Twenty Pounds sterling, for defraying the expense of granting these Letters of Registration, as required by the Act of Council, sixteenth Victoria, number twenty-four; and have humbly prayed that I would be pleased to grant Letters of Registration, whereby the exclusive enjoyment and advantage of the said invention or improvement might be secured to them for a period of fourteen years: And I, being willing to give encouragement to all inventions and improvements in the arts or manufactures which may be for the public good, and having received a report favourable to the prayer of the said Petition, from competent persons appointed by me to examine and consider the matters stated therein and to report thereon for my information, am pleased, with the advice of the Executive Council, and in exercise of the power and authority given to me by the said Act of Council, to grant, and do by these Letters of Registration grant unto the said Thomas Rowland Jordan and John Needham Longden, their executors, administrators, and assigns, the exclusive enjoyment and advantage of the said invention or improvement, for and during the term of fourteen years from the date hereof; to have, hold, and exercise unto the said Thomas Rowland Jordan and John Needham Longden, their executors, administrators, and assigns, the exclusive enjoyment and advantage thereof, for and during and unto the full end and term of fourteen years from the date of these presents next and immediately ensuing, and fully to be complete and ended: Provided always, that if the said Thomas Rowland Jordan and John Needham Longden shall not, within three days after the granting of these Letters of Registration, register the same in the proper office of the Supreme Court at Sydney, in the said Colony of New South Wales, then these Letters of Registration, and all advantages whatsoever hereby granted, shall cease and become void.

In witness whereof, I have hereunto set my sign manual, and have caused the present Letters of Registration to be sealed with the seal of the said Colony of New South Wales, at Government House, Sydney, in New South Wales, this twenty-ninth day of April, in the year of our Lord one thousand eight hundred and eighty-four.

[L.s.]

ALFRED STEPHEN,
(Acting by virtue of a Deputation from His Excellency the Governor.)

An Improved Method for Extracting Metals from their Ores.

SPECIFICATION of THOMAS ROWLAND JORDAN, of Gracechurch-street, in the city of London, England, engineer, and JOHN NEEDHAM LONGDEN, of Charters Towers, Queensland, but now residing in London, England, mining engineer, for an invention entitled "An improved method or process and apparatus for extracting metals from their ores and concentrating heavy materials."

THIS invention relates to a novel method or process of treating ores containing silver and gold, to extract or separate the precious metals, which process also comprises the concentration of the residue of such ores and other heavy materials.

The said method or process consists in a series of consecutive operations carried into effect by a peculiar combination of machinery or apparatus as hereinafter described. Our invention is characterized by the treatment of the ores in a dry state, that is to say, by using air instead of water as the medium for automatically conveying or transferring the pulverized ore through the said apparatus. The said invention is not restricted or limited to the use of any special features of construction of such machinery or apparatus otherwise than in respect of the capability of each machine or apparatus, or each part thereof, to perform its specific function or functions in the said process or series of operations as herein specified. But for the purpose of performing these operations consecutively, as and for the purpose herein specified, the novel combination of such machines or apparatus in the order specified forms a subordinate part of our said invention.

The accompanying drawing is a plan showing the arrangement of the combined machines used in carrying our invention into practice.

For breaking the ore we use a stone-breaker A of the usual or any suitable construction. This machine delivers its produce by a chute *a* into a pulverizer B capable of reducing the broken ore to an extremely fine or small condition. As an example of the class or type of machine or apparatus requisite for this purpose, we here specify that commonly known as the "Jordan Patent Pulverizer." From this machine the pulverized material containing the gold or silver is delivered by an air current through a pipe or pipes *b* into a receiving chamber C. In this chamber it may be separated by the air current into different degrees of fineness, specific gravity, and value, and, if necessary, is concentrated therein, each grade being then passed by a screw-conveyor D or other suitable means to an amalgamator E F or G by a chute *c*. We may use any number, form, or kind of amalgamators, but by preference we employ such as are described in the specification of the said Thomas Rowland Jordan, filed with his application for Letters Patent on the same date as that of our present application.

In the arrangement shown we employ the three machines described in the said specifications, which machines are marked E F and G in the accompanying drawing.

After passing through the amalgamators, the residues or tailings are subjected to a further process of separation by a current or blast of air over the surface of the mercury, which blast conveys the tailings through a concentrating chamber, over which they are distributed by the air current, the particles of different density or specific gravity falling into the various divisions of the said concentrator, and the waste material being blown away to any required distance.

CLAIMS.

First—An automatic and continuous process for the extraction of gold and silver from their ores by reduction and amalgamation with mercury without the use of water, substantially as described.

Second—The continuous method or process of extracting or separating metals from their ores, consisting in the series of operations herein specified, carried into effect in and by the aid of the machinery or apparatus above set forth, or equivalent apparatus, arranged and operating in such a manner as to effect the reduction of the ores in a dry state.

Third—As a part of the said process, or as a further process of treating ores, or other heavy materials, the employment of the concentrating apparatus in the manner and for the purpose specified.

Fourth—In the said continuous process, the application and utilization of an air-blast, substantially as and for the purpose specified.

In witness whereof, we, the said Thomas Rowland Jordan and John Needham Longden, have hereto set our hands and seals, this twenty-ninth day of February, one thousand eight hundred and eighty-four.

T. R. JORDAN.

J. N. LONGDEN.

(By their Agent, EDWD. WATERS).

This is the specification referred to in the annexed Letters of Registration granted to Thomas Rowland Jordan and John Needham Longden, the 29th day of April, A.D. 1884.

ALFRED STEPHEN.

REPORT.

Sir,

Sydney, 8 March, 1884.

The petition of Messrs. Thomas Rowland Jordan and John Needham Longden, for Letters of Registration for an invention entitled "An improved method or process and apparatus for extracting metals from their ores and concentrating heavy materials," having been referred to us, we have examined the specification and drawing accompanying the same, and have the honor to report that we see no objection to the issue of Letters of Registration as prayed for.

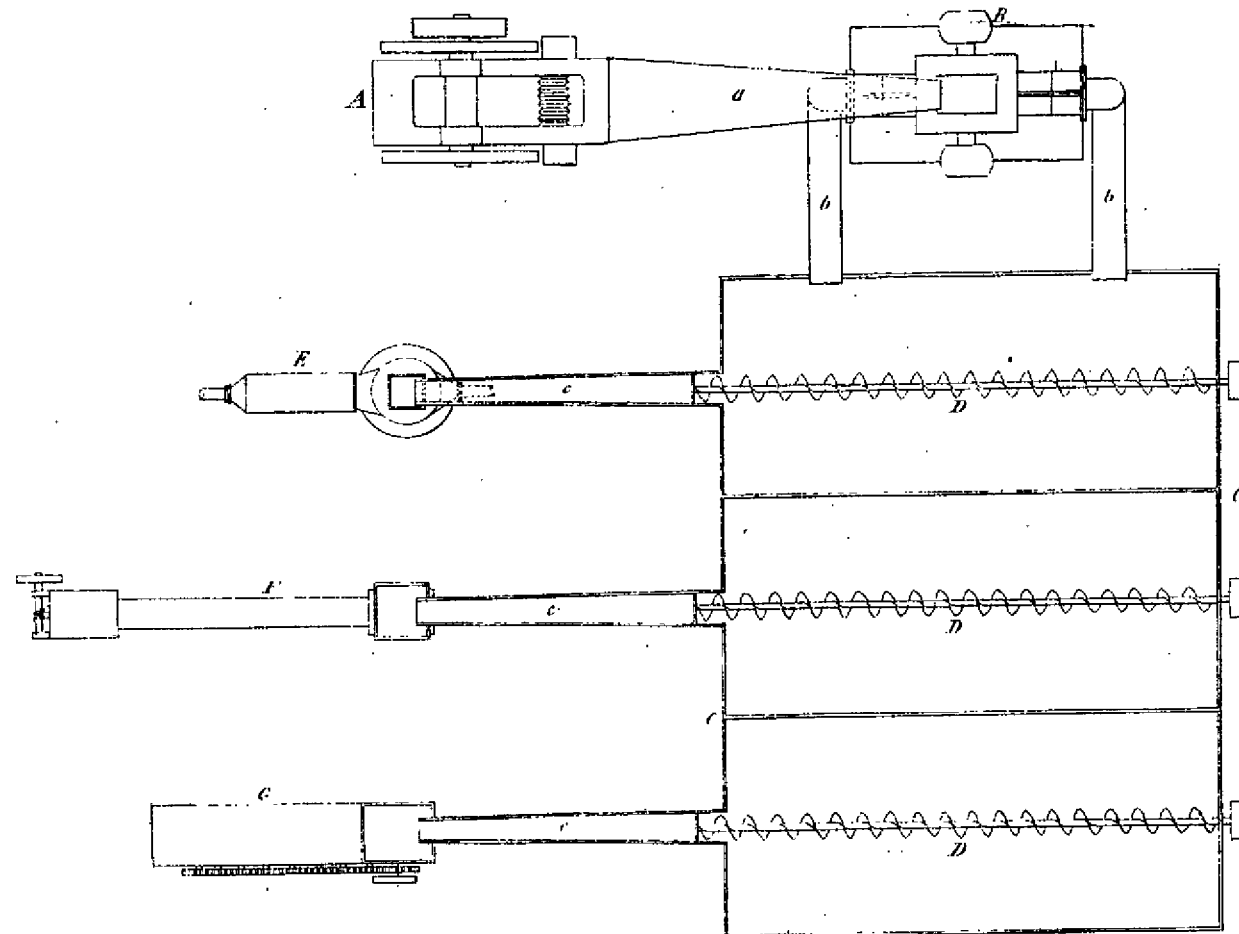
We have, &c.,

J. SMITH.

A. LEIBIUS.

The Under Secretary of Justice.

JORDAN & LONGDEN'S PATENT



This is the Sheet of Drawings referred to in the annexed Letters of Registration, granted to Thomas Rowland Jordan, and John Needham Longden, this twentieth day of April, A.D. 1884.

Alfred Stephen.

(Sig: 245~)



A.D. 1884, 29th April. No. 1422.

IMPROVEMENTS IN MACHINERY OR APPARATUS FOR TREATING ORES.

LETTERS OF REGISTRATION to Thomas Rowland Jordan, for Improvements in Machinery or Apparatus for treating Ores, chiefly for the extraction of Precious Metal therefrom.

[Registered on the 30th day of April, 1884, in pursuance of the Act 16 Vic. No. 24.]

BY HIS EXCELLENCY THE RIGHT HONORABLE SIR AUGUSTUS WILLIAM FREDERICK SPENCER LOFTUS (commonly called LORD AUGUSTUS LOFTUS), Knight Grand Cross of the Most Honorable Order of the Bath, a Member of Her Majesty's Most Honorable Privy Council, Governor and Commander-in-Chief of the Colony of New South Wales and its Dependencies.

TO ALL TO WHOM THESE PRESENTS SHALL COME, greeting :

WHEREAS THOMAS ROWLAND JORDAN, of Gracechurch-street, in the city of London, England, engineer, hath by his Petition humbly represented to me that he is the author or designer of a certain invention or improvement in manufactures, that is to say, of an invention entitled "Improvements in Machinery or Apparatus for treating Ores, chiefly for the extraction of precious metal therefrom," which is more particularly described in the specification and the sheet of drawings which are hereunto annexed ; and that he, the said Petitioner, hath deposited with the Honorable the Treasurer of the said Colony of New South Wales the sum of Twenty Pounds sterling, for defraying the expense of granting these Letters of Registration, as required by the Act of Council, sixteenth Victoria, number twenty-four ; and hath humbly prayed that I would be pleased to grant Letters of Registration, whereby the exclusive enjoyment and advantage of the said invention or improvement might be secured to him for a period of fourteen years : And I, being willing to give encouragement to all inventions and improvements in the arts or manufactures which may be for the public good, and having received a report favourable to the prayer of the said Petition, from competent persons appointed by me to examine and consider the matters stated therein and to report thereon for my information, am pleased, with the advice of the Executive Council, and in exercise of the power and authority given to me by the said Act of Council, to grant, and do by these Letters of Registration grant unto the said Thomas Rowland Jordan, his executors, administrators, and assigns, the exclusive enjoyment and advantage of the said invention or improvement, for and during the term of fourteen years from the date hereof ; to have, hold, and exercise unto the said Thomas Rowland Jordan, his executors, administrators, and assigns, the exclusive enjoyment and advantage thereof, for and during and unto the full end and term of fourteen years from the date of these presents next and immediately ensuing, and fully to be complete and ended : Provided always, that if the said Thomas Rowland Jordan shall not, within three days after the granting of these Letters of Registration, register the same in the proper office in the Supreme Court, at Sydney, in the said Colony of New South Wales, then these Letters of Registration, and all advantages whatsoever hereby granted, shall cease and become void.

In witness whereof, I have hereunto set my sign manual, and have caused the present Letters of Registration to be sealed with the seal of the said Colony of New South Wales, at Government House, Sydney, in New South Wales, this twenty-ninth day of April, in the year of our Lord one thousand eight hundred and eighty-four.

[L.S.]

ALFRED STEPHEN,

(Acting by virtue of a Deputation from His Excellency the Governor.)

Improvements in Machinery or Apparatus for treating Ores.

SPECIFICATION of THOMAS ROWLAND JORDAN, of Gracechurch-street, in the city of London, England, engineer, for an invention entitled "Improvements in Machinery or Apparatus for treating Ores, chiefly for the extraction of precious metal therefrom."

My invention relates to improvements in machinery or apparatus for passing ores containing gold or silver in a finely-divided condition through mercury or other amalgamating agent for the purpose of separating the precious metals from such ores by amalgamation, and for concentrating the residue of such ores or similar materials.

The special construction of this machinery or apparatus is designed with a view to introduce the ore sand under a head of mercury or other amalgamating agent, and to retain the particles in a finely-divided condition in or under the mercury or other material during any length of time necessary to effect the amalgamation of all the gold or silver contained in the sand; and, further, to recover from the tailings passing from the said machine the "sickened" mercury or other valuable metallic substance which may be contained therein.

According to one part or modification of my invention, the said machinery or apparatus is constructed as shown in figures 1 and 2, of which figure 1 is a plan or top view, and figure 2 a central vertical section partly in elevation.

The machine shown in these figures has a circular pan *a* of any required dimensions; this pan is constructed with a conical bottom *a*¹, and a cover *a*², and preferably provided with a steam jacket *a*³. In this pan *a* I arrange a vertical tube *b*, provided with a hopper *c* at its upper end, the said tube being provided with cone pulleys *d*, or other means whereby it may be revolved at any required speed. To the lower end of this tube *b*, or in any position thereon which is under the required depth or head of mercury, I attach a device *e*, which I term an injector, and which revolves with the said tube. The construction of this injector is peculiar, and is illustrated in figures 3 and 4, of which figure 3 is a horizontal section, and figure 4 is a vertical central section, both drawn to an enlarged scale; it comprises two circular plates or discs *e*¹ kept apart by blocks *e*² of wood or metal. These blocks are so arranged and curved from the centre to the periphery of the said discs as to form one or more passages *e*³, which extend from the aperture at the lower end of the vertical pipe *b* to the exterior of the injector.

In figure 2^a, which is a central section, I have shown a modification wherein I use a conical tube or pipe for the introduction of the sand into the amalgamating fluid or agent. I sometimes use an agitator arranged in any suitable manner to be rotated within the said tube to prevent the clogging of the ore-sand therein.

I, in some instances, modify the said injector by constructing it without the bottom disc, and making the aforesaid blocks from two to three inches deep at the side marked *e*⁴, and inclined to a feather edge at the side marked *e*⁵, the curved form of these blocks and the passages between them being retained, as above described. This modification of the injector is shown in vertical central section in figure 5. Further modifications are shown in horizontal section in figures 3^a, 3^b, 3^c, all these figures being also drawn to an enlarged scale.

The portion of the vertical tube *b* immersed in the mercury (the level of which is shown by a dotted line in figure 1) is surrounded by a drum *f* to which I attach blades, vanes, or wings *g*. These blades *g* project from the drum into the mercury, and extend nearly to the inner cylindrical surface of the pan *a* as shown. Provision is made for setting them at any required angle. A pulley *h*, a worm *h*¹, and a worm wheel *h*², or other suitable means, are provided for rotating the said drum and blades slowly in the reverse direction to that in which the vertical tube *b* rotates.

I sometimes form one or more passages in the drum *f* and tube *b*, as shown by dotted lines in figure 1, to cause a circulation of the mercury or other fluid when the tube and drum are rotated. Each passage has at one side an extension or projection *f*¹ to ensure the entrance of the fluid into the tube *b*.

At the upper part of the pan *a*, and in such a position as to be near and above the surface of the mercury (when the pan is properly filled therewith), I provide a pipe *i*, the mouth or orifice of which is flat and narrow. On the opposite side of the pan, and in the same horizontal plane, or nearly so, I arrange an outlet pipe or passage *j* leading to a concentrating chamber *k*. This part of the apparatus is constructed of wrought iron or other suitable material, and is divided at its lower portion into two or more compartments *k*¹ by vertical partitions. These partitions are each composed of a fixed plate *l*, and an adjustable plate *l*¹, the latter plate being secured by bolt *l*² passing through slots therein. Each compartment has a conical bottom *k*² and a sliding door *k*³. A waste pipe *m* is introduced at the top of the said chamber opposite the pipe or passage *j*, whereby the material enters from the pan *a*.

In using the above-described machine the ore-sand is fed into the hopper *c*, at the top of the central revolving tube *b*, and passing down this tube to the injector *e* is centrifugally forced into the mercury, in which a space is created to receive it by the peculiar form and action of the aforesaid injector. When entering the mercury the immediate tendency of the ore-sand is to rise rapidly to the surface thereof, and thus to escape too quickly for the precious metal to be properly extracted by amalgamation; this premature escape is, however, prevented by the aforesaid revolving blades *g*, which regulate the time of the retention of the ore in the mercury. These blades can be varied or adjusted in respect of their number, their angle, or their velocity, to suit different qualities of ore.

The sand on reaching the surface of the mercury in the pan encounters a blast from the aforesaid air-supply pipe *i*; this blast blows the sand through the pipe or passage *j* and across the compartments of the concentrating chamber, the particles of sand fall into the different compartments of the said chamber according to their specific gravity, the light waste being conveyed by the air current to the waste pipe *m*, which is suitably arranged to conduct it away from the concentrating chamber.

The amalgam formed in the pan *a* settles in the conical bottom *a*¹ thereof, and is drawn off at convenient intervals through a valve or cock *a*⁴ or other means provided for this purpose. A pipe *a*⁴ is provided for drawing off the liquid mercury or other amalgamating agent when desired.

According to another part of my invention, I provide for treating the ore-sand or the concentrated tailings as follows, that is to say:—I use the apparatus illustrated in figures 6 and 7, of which figure 6 is a longitudinal vertical section, and figure 7 is a section on the line *x x*, figure 6. This apparatus has two tanks *n n*¹ constructed of wrought or cast iron and connected by a tube *o*. In this tube, and extending through

Improvements in Machinery or Apparatus for treating Ores.

through the same, I arrange a spiral brush p , or a spiral blade, and in combination therewith I insert pegs or pins q of copper or other suitable material in the tube, so arranged that they project towards the centre of the same, as shown; a feed hopper r is fitted on the tank n , and a convenient worm and worm-wheel s or other suitable gearing is provided for rotating the spiral brush or blade at any required speed. Below the hopper the tube o is provided with a helical blade o^2 , and the brush is circular at this part. The tank n^1 and tube o are to be filled with mercury to the level of the upper portion of the tube o ; a return tube o^* connects the two ends of the tube o to keep the mercury at the same level in all parts throughout the said tube and the tank n^1 . A cock o^1 is provided in this tube for regulating the return of the mercury. The tank n , as shown, is designed to serve as a support for the hopper and one end of the tube o , and to receive any mercury that may overflow from the tube o ; but the said tank may also be filled with mercury in some cases.

The sand or tailings are fed into the hopper r , and by the action of the revolving spiral brush p , and the circulation of the mercury, will be gradually drawn through the tube o and the mercury to the tank n^1 ; at this stage of the operation the heavy amalgam drops to the bottom of the tank n^1 , whence it can be drawn off by a valve or other suitable means. The light sand ascends to the surface of the mercury, where it encounters a blast of air, for which provision is made, as shown in figures 1 and 2, or in any other suitable manner.

In combination with the above-described apparatus, or separately therefrom, I use the apparatus shown in figures 8, 9, and 10, of which figure 8 is a longitudinal vertical section, figure 9 is a plan, and figure 10 is a transverse section. This apparatus is constructed with a tank t containing a number of circular brushes w^1, w^2, w^3, w^4, w^5 , so arranged that their peripheries meet each other, the line passing through their centres being horizontal or slightly inclined. Their length is such that they fill, or nearly fill, the said tank, as shown in figure 10. A hopper v is placed at one end of the tank t , the first brush w^1 being fed directly from the same. The ore-sand or tailings being thus fed to the first brush will be conveyed or driven by the series of brushes through the mercury. All the brushes are rotated in the same direction by suitable gearing outside the tank, as shown in figures 9 and 10, the sand conveyed under the mercury by the first brush is again passed forward by the next brush, and so on as many times as there are brushes until the waste material is finally brushed out over the end of the tank, and a suitable receptacle is provided to receive and collect the amalgam as it comes from the outlet t' .

This apparatus is sometimes provided with a pipe w having a cock w^1 to permit the return of the mercury from one end of the tank t to the other end thereof.

CLAIMS.

- First—An amalgamating machine wherein the passage of the ore-sand through the amalgamating fluid or agent is continuously retarded or controlled for the purpose above set forth.
- Second—In a machine for extracting metals from their ores by amalgamation, the use of a revolving pipe and injector for forcing the sand under a head of the amalgamating fluid or agent in combination with screw-blades or brushes arranged to rotate in the amalgamating fluid or agent for the purpose of retarding and controlling the rising of the sand to the surface and for subdividing and distributing the particles of the sand while subjected to the action of the said fluid or agent.
- Third—In an amalgamating machine for the purposes above described, the application of an air-blast over the surface of the mercury for conveying the tailings away through a concentrating chamber or separator.
- Fourth—In an amalgamating machine, for the purposes above described, the use of a revolving spiral blade or brush in a tube filled or partially filled with an amalgamating fluid or agent for the purpose of drawing or forcing the sand through the said fluid or agent.
- Fifth—In an amalgamating machine, maintaining a slow circulation of the amalgamating fluid or agent by means of a spiral blade or brush, or by the rotation of the tube for the purpose of passing ore-sand through the same in the manner described.
- Sixth—In an amalgamating machine, the use of a series of revolving brushes for repeatedly passing ore-sand through a bath of mercury as an automatic continuous process.
- Seventh—The amalgamating machine consisting of the parts constructed and combined substantially as shown in figures 1 and 2, and operating as set forth for the purposes specified.
- Eighth—The amalgamating machine consisting of the parts constructed and combined substantially as shown in figures 6 and 7, and operating as set forth for the purposes specified.
- Ninth—The amalgamating machine consisting of the parts constructed and combined substantially as shown in figures 8, 9, and 10, and operating as set forth for the purposes specified.
- Tenth—In an amalgamating machine, the use of a conical pipe or tube as above described for introducing the ore-sand into the amalgamating fluid or agent.
- Eleventh—In an amalgamating machine, the use of an agitator, arranged within the tube for introducing the ore-sand into the mercury to prevent the clogging of the sand in the said tube, substantially as described.

In witness whereof, I, the said Thomas Rowland Jordan, have hereto set my hand and seal, this twenty-ninth day of February, one thousand eight hundred and eighty-four.

T. R. JORDAN,

(By his Agent, EDWD. WATERS).

This is the specification referred to in the annexed Letters of Registration granted to Thomas Rowland Jordan, this twenty-ninth day of April, A.D. 1884.

ALFRED STEPHEN.

Improvements in Machinery or Apparatus for treating Ores.

REPORT.

Sir,

Sydney, 8 March, 1884.

The petition of Mr. Thomas Rowland Jordan for Letters of Registration for an invention entitled "Improvements in Machinery or Apparatus for treating Ores, chiefly for the extraction of precious metal therefrom," having been referred to us, we have examined the specification and drawings accompanying the same, and have now the honor to report that we see no objection to the issue of Letters of Registration, in accordance with the specification, drawings, and claims.

We have, &c.,
J. SMITH,
A. LEIBIUS.

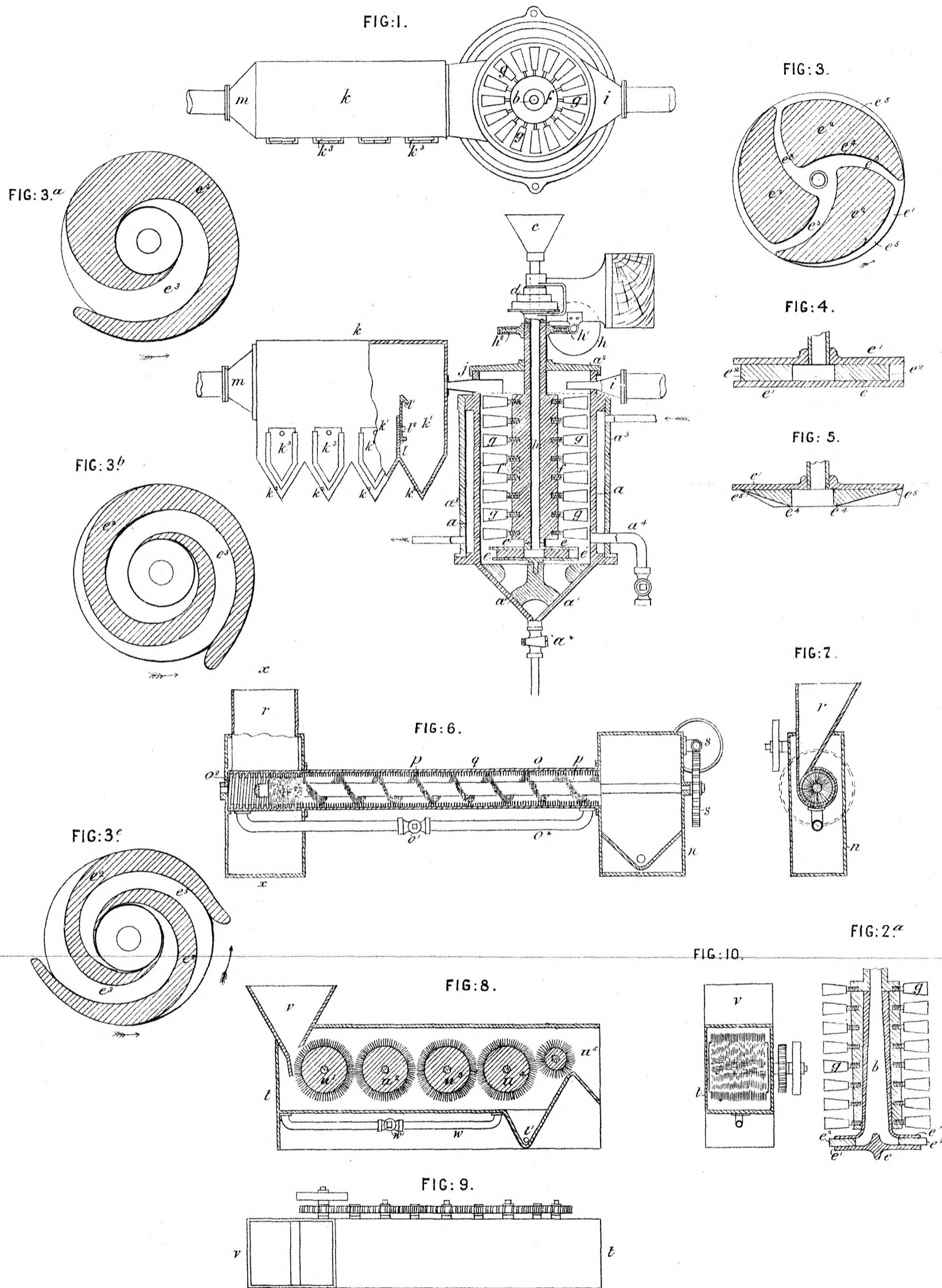
The Under Secretary of Justice.

[Drawings—one sheet.]

No. 1423.

[Assignment of No. 1185. See Letters of Registration for 1883, page 35.]

T.R.JORDAN'S PATENT.



This is the Sheet of Drawings referred to in the annexed Letters of Registration granted to Thomas Rowland Jordan, this twenty-ninth day of April, A.D. 1884.

Alfred Stephen.



A.D. 1884, 9th May. No. 1424.

IMPROVEMENTS IN SUSPENDERS OR BRACES.

LETTERS OF REGISTRATION to Thomas Otis Potter, for Improvements in Suspenders or Braces.

[Registered on the 10th day of May, 1884, in pursuance of the Act 16 Vic. No. 24.]

BY HIS EXCELLENCY THE RIGHT HONORABLE SIR AUGUSTUS WILLIAM FREDERICK SPENCER LOFTUS (commonly called LORD AUGUSTUS LOFTUS), Knight Grand Cross of the Most Honorable Order of the Bath, a Member of Her Majesty's Most Honorable Privy Council, Governor and Commander-in-Chief of the Colony of New South Wales and its Dependencies.

TO ALL TO WHOM THESE PRESENTS SHALL COME, greeting :

WHEREAS THOMAS OTIS POTTER, of Boston, in the County of Suffolk, in the State of Massachusetts, one of the United States of America, gentleman, hath by his Petition humbly represented to me that he is the author or designer of a certain invention or improvement in manufactures, that is to say, of an invention entitled "Improvements in Suspenders or Braces," which is more particularly described in the specification and the sheet of drawings which are hereunto annexed ; and that he, the said Petitioner, hath deposited with the Honorable the Treasurer of the said Colony of New South Wales the sum of Twenty Pounds sterling, for defraying the expenses of granting these Letters of Registration, as required by the Act of Council, sixteenth Victoria, number twenty-four ; and hath humbly prayed that I would be pleased to grant Letters of Registration whereby the exclusive enjoyment and advantage of the said invention or improvement might be secured to him for a period of fourteen years : And I, being willing to give encouragement to all inventions and improvements in the arts or manufactures which may be for the public good, and having received a report favourable to the prayer of the said Petition, from competent persons appointed by me to examine and consider the matters stated therein and to report thereon for my information, am pleased, with the advice of the Executive Council, and in exercise of the power and authority given to me by the said Act of Council, to grant, and do by these Letters of Registration grant unto the said Thomas Otis Potter, his executors, administrators, and assigns, the exclusive enjoyment and advantage of the said invention or improvement for and during the term of fourteen years from the date hereof ; to have, hold, and exercise unto the said Thomas Otis Potter, his executors, administrators, and assigns, the exclusive enjoyment and advantage thereof, for and during and unto the full end and term of fourteen years from the date of these presents next and immediately ensuing, and fully to be complete and ended : Provided always, that if the said Thomas Otis Potter shall not, within three days after the granting of these Letters of Registration, register the same in the proper office in the Supreme Court, at Sydney, in the said Colony of New South Wales, then these Letters of Registration, and all advantages whatsoever hereby granted, shall cease and become void.

In witness whereof, I have hereunto set my sign manual, and have caused the present Letters of Registration to be sealed with the seal of the said Colony of New South Wales, at Government House, Sydney, in New South Wales, this ninth day of May, in the year of our Lord one thousand eight hundred and eighty-four.

[L.S.]

AUGUSTUS LOFTUS.

Improvements in Suspenders or Braces.

SPECIFICATION of THOMAS OTIS POTTER, of Boston, Massachusetts, United States of America, gentleman, for an invention entitled "Improvements in Suspenders or Braces."

My invention relates to suspenders or braces, and the following is a full, clear, and exact description of the construction thereof, reference being had to the accompanying drawings, forming a part of the specification, in more fully explaining the nature of the invention, in which figure 1 shows in perspective a pair of suspenders or braces containing some of the features of my invention. Figure 2 is an elevation of one of the intermediate button-hole loops or connections of figure 1. Figure 3 is a plan of a metallic blank, from which the housing for the pulley is formed. Figure 4 is a central section of the housing pulley, and end of the strap or webbing with which it is used. Figure 5 represents a pair of suspenders containing certain features not shown in figure 1. Figures 6 and 7 are cross-sections, the first on the line XX of figures 1 and 2, and the second on the line YY, represent modifications of the construction of the housing and pulley to adapt them to be used either as a hook or with a hook. Figure 8 is a perspective and cross-section of a metallic clasp or binder, for fastening the end of a cord or web to itself, to form a button-hole. Figure 9 represents in elevation a metallic clamping device, for uniting the converging ends of straps or webbing. Figure 10 is a reverse view thereof. Figures 11, 12, 13, 14, 15, 16, and 17 relate to modifications in the use of the clamping device hereinafter specifically referred to. Figure 18 represents a metallic clasp of a different shape from that shown in figure 8. The principal features of my invention consist:—First, in providing the ends of the shoulder webs or straps of suspenders or braces with pulleys, secured in position, and to the end of the straps by metallic housings, and combining therewith two independent cords or straps, having button-holes at either end. Second, in combining with the shoulder-straps and independent cords or straps attached as above indicated, an intermediate connecting cord and pulley, as shown in figure 1. Third, in the novel construction of the metallic housing for the pulleys, whereby the pulleys are secured in place, and the housing adapted to be attached to the web or strap so as to be kept in proper position by the same. Fourth, in forming the button-holes by turning the end of the strap, cord, or webbing back upon itself, to form a loop, and securing the end to the part or portion against which it is turned by a splice or metallic clasp. Fifth, in means for fastening the contiguous ends of two straps or pieces together. In order that those skilled may fully understand how to make and use my invention, I will proceed to describe the same, referring by letters to the drawings. AA are the main shoulder-straps; they are connected at B in any well-known way; adjustably secured to the ends of these straps are metallic housings C (see figure 1), in which are secured pulleys D, which are free to turn on their axes, as will be presently explained. EE are two cords, the ends of which are formed into button-holes by returning the cord upon itself and securing it by a splice or metallic clasp. These two cords are passed over the pulleys at the ends of the webs, as shown in figure 1, and are free to render through the said pulleys. FF are two short cord or webbing connections, carrying at their ends the metallic housings G and pulleys, through which the cords E pass, and which connections have button-holes at their lower ends, by which they are fastened to the pantaloons (see figures 1 and 2). The metal housing C is formed from a blank C', which has long slots H at each end, and the perforations H for the pulley axes bearing. This blank is bent at its centre so that the two slots H will come together and coincide. The balance of the blank is spread apart to receive the pulley, which is secured thereto, so as to be capable of rotation. The main straps AA are passed through slot H, and fastened to the main portion of the straps by buckles (see figure 1), while I prefer to use the intermediate connecting device F, yet the cords E may have two button-holes at one end, and one at the other if desired, or the suspenders may be connected with the pantaloons at four points only, instead of at six. By this construction and arrangement the greatest freedom of action is allowed the wearer, without undue strain upon the straps or cords and buttons, although the straps and cords used are not elastic, for the reason that the cords are perfectly free to render through the pulleys and adapt themselves to the changing positions of the wearer. In figure 5 the metallic housings for the pulleys are somewhat different from those represented in figure 1, and their construction is shown more particularly in figures 6 and 7. The housing completely shields the sheave which is secured thereto, to be revolved, and the upper end or ends of the housing has a hole as in figure 7, or a hook as is shown in figure 6. I prefer to use, in forming button-holes, the metallic clasp E' shown in figures 5 and 8, the side edges of which are parallel for about half their length, from which point they decrease in width to such an extent that when folded and clasped around the cord and loop the broad portion of the clasp will embrace and confine in a fixed relation the cord *e* and its end *e'*, while the narrow or converging end of the clasp will, when closed, tightly surround the cord, only forming another grasping point, and at the same time concealing from view the end of the cord, and affording a neat and smooth finish. The clasp before it is applied may be partially formed, and the cord and its end arranged therein, when the outer portions are bent over upon the cord as shown, either by hand or by a press, and the clasp then assumes the form of substantially a double hollow cylinder at one end, and a single cylinder at the other end. If preferred, dies may be used for closing the clasp upon the cord, in which event it may be clasped or pressed in longitudinally at the time the clasp is applied to the cord, if desired. In addition to the clamping action, I prefer to provide the clasp additionally with barbs or points, which shall project inwardly and penetrate the cords and securely hold them in position. These barbs are formed preferably on the end of the metal, by cutting and turning in, but of course they may be made on any portion of the clasp without departing from the spirit of the invention. In figures 9 to 17 inclusive I show a fastening device for connecting or securing together the converging ends of straps comprising the plate M, whose edges are substantially parallel with the outer edge of the two converging straps, and the plate M', which has wings or extensions that are adapted to be bent over the sides of the plate *m*, upon the under surface thereof as shown in figure 10, and so locking the two plates and strap ends together. These plates are provided with spurs or points, which are formed by striking down, punching, or cutting from the metal itself, and the spurs or points are compressed into the material or straps in the act of applying the clamps. These clamping plates may be formed from blanks substantially like those shown in figures 11 and 12, or they may be made from separate blanks as represented in figures 14 and 15, in which case they must be connected by rivets or eyelets, or in some other way. The clamping plates may have holes for use with a hook, or they may have a hook to be used with the hole formed in the other clamping plate, or they may have slots through which the webbing is inserted. In figure 18 I represent a clasp similar to that shown in
figure

Improvements in Suspenders or Braces.

figure 8, the difference being that its diameter is not reduced, and that it is adapted to clamp two ends of a small cord to form a button-hole and unite or secure it to a larger cord or webbing. The advantages of the invention arising from the rendering of the lower straps or cords in relation to the shoulder straps are obvious, and those arising from the special feature of construction are important, because of the increased wear and durability obtained, and the cheapening of the cost of manufacture. Having thus fully described my invention, I claim and desire to secure by Letters Patent:—1. The improved brace or suspender, consisting of two shoulder straps, provided at their front and back ends with metallic housings and pulleys, in combination with two independent cords or straps EE provided at each end with button-holes, the cords or straps E being arranged to render through the front and rear of the pulleys respectively of each of the straps AA, substantially as and for the purposes set forth. 2. In combination with the main straps AA, and two independent cords or straps EE, arranged as described, the intermediate and independent connection F, secured to the cords EE, in the manner described and for the purposes set forth. 3. The sheet-metal housing C, formed at each end with loops or slots H, perforated, and swelled or enlarged around said perforation, to receive the pulley, whereby the pulley is secured and concealed, and the housing secured to the strap, substantially as and for the purposes set forth. 4. As a new article of manufacture, a suspender end formed from a single cord or strap, the end thereof being returned upon itself, and fastened in position to form a button-hole, substantially as and for the purposes set forth. 5. A metal clasp, having the double curved back portion and its edges bent up at right angles, the said edges being parallel for a portion of the length of the clasp, and then converging or inclined toward one end, substantially as and for the purposes set forth. 6. A suspender end composed of a cord or strap, the end of which is doubled or returned to form a button hole, and fastened in such position by a metal clasp, having when applied the form substantially of a double hollow cylinder at one end, and a single cylinder at the other, and adapted to conceal the end of the cord, substantially as specified. 7. A metallic clasp for securing the cord to form a button-hole, which when applied shall have the form of a double hollow cylinder at its lower end, and a single hollow cylinder at its upper end, and provided with harbs, substantially as and for the purposes set forth. 8. The sheet-metal housing C, having its lower end open, and extending down to cover the sides of the pulley, and its upper end formed with a slot or hook, as described, whereby a shield is afforded for the pulley, and the strain upon the upper end of the housing shall tend to hold it in position, as hereinbefore set forth. 9. As a means of fastening the converging ends of straps together, the plates MM', each of which has inwardly projecting prongs or spurs, and one of which has wings which lap upon the other, and fastens the two parts and straps together as described, either when provided with a hooked, slotted, or other end, as shown and set forth. And I do hereby for myself, my heirs, executors, and administrators, covenant with Her Majesty, her heirs and successors, that I believe the said invention to be a new invention, as to the public use and exercise thereof, and that I do not know or believe that any other person than myself is the true and first inventor of the said invention, and that I will not deposit these presents at the office of the Registrar-General with any such knowledge or belief as last aforesaid.

In witness whereof, I have hereunto set my hand and seal, this fifth day of January, one thousand eight hundred and eighty-four.

In presence of—

F. F. RAYMOND.
FRED. B. DOLAN.

THOMAS OTIS POTTER.

This is the specification referred to in the annexed Letters of Registration granted to Thomas Otis Potter, this 9th day of May, A.D. 1884.

AUGUSTUS LOFTUS.

REPORT.

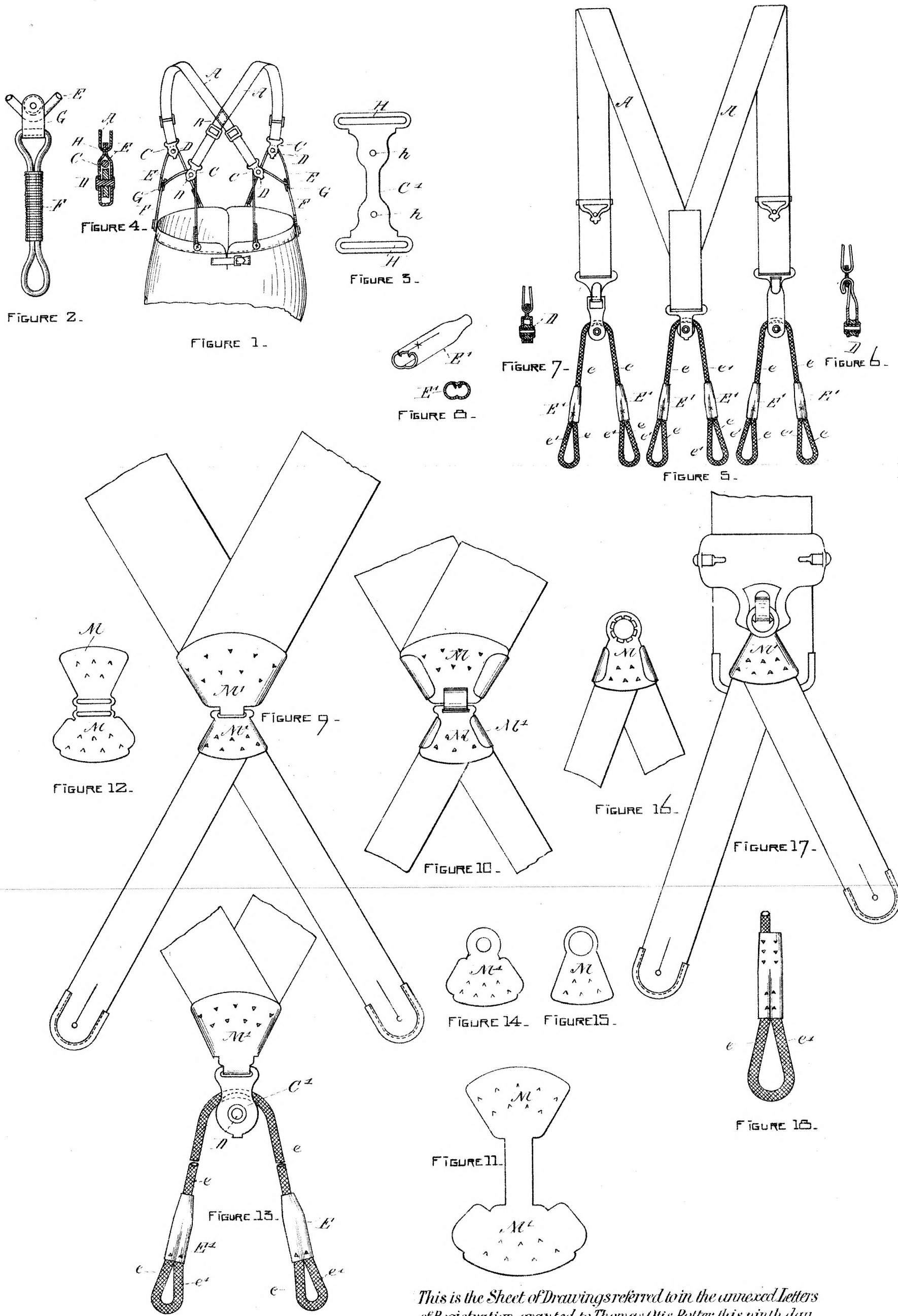
Sir,

Sydney, 19 March, 1884.

The application of Thomas Otis Potter for Letters of Registration for an invention entitled "Improvements in Suspenders or Braces," having been referred to us for report, we have examined the specification and plan accompanying the same, and have now the honor to report that we see no objection to the issue of Letters of Registration as applied for.

We have, &c.,
ARCH. C. FRASER.
THOS. RICHARDS.

The Under Secretary of Justice.



(Sig. 245~)

This is the Sheet of Drawings referred to in the annexed Letters of Registration, granted to Thomas Otis Potter, this ninth day of May, A. D., 1884.

Augustus Loftus.



A.D. 1884, 9th May. No. 1425.

IMPROVED LOCOMOTIVE BRAKE.

LETTERS OF REGISTRATION to William Edward Wilson, for an Improved Locomotive Brake.

[Registered on the 10th day of May, 1884, in pursuance of the Act 16 Vic. No. 24.]

BY HIS EXCELLENCY THE RIGHT HONORABLE SIR AUGUSTUS WILLIAM FREDERICK SPENCER LOFTUS (commonly called LORD AUGUSTUS LOFTUS), Knight Grand Cross of the Most Honorable Order of the Bath, a Member of Her Majesty's Most Honorable Privy Council, Governor and Commander-in-Chief of the Colony of New South Wales and its Dependencies.

TO ALL TO WHOM THESE PRESENTS SHALL COME, greeting :

WHEREAS WILLIAM EDWARD WILSON, of Sydney, in the Colony of New South Wales, accountant, hath by his Petition humbly represented to me that he is the agent of Ebenezer Beals, of Chenango, State of New York, United States of America, who is the author or designer of a certain invention or improvement in manufactures, that is to say, of an invention entitled "An Improved Locomotive Brake," which is more particularly described in the specification and the sheet of drawings which are hereunto annexed; and that he, the said Petitioner, hath deposited with the Honorable the Treasurer of the said Colony of New South Wales the sum of Twenty Pounds sterling, for defraying the expense of granting these Letters of Registration, as required by the Act of Council, sixteenth Victoria, number twenty-four; and hath humbly prayed that I would be pleased to grant Letters of Registration, whereby the exclusive enjoyment and advantage of the said invention or improvement might be secured to him for a period of fourteen years: And I, being willing to give encouragement to all inventions and improvements in the arts or manufactures which may be for the public good, and having received a report favourable to the prayer of the said Petition, from competent persons appointed by me to examine and consider the matters stated therein and to report thereon for my information, am pleased, with the advice of the Executive Council, and in exercise of the power and authority given to me by the said Act of Council, to grant, and do by these Letters of Registration grant unto the said William Edward Wilson, his executors, administrators, and assigns, the exclusive enjoyment and advantage of the said invention or improvement for and during the term of fourteen years from the date hereof; to have, hold, and exercise unto the said William Edward Wilson, his executors, administrators, and assigns, the exclusive enjoyment and advantage thereof, for and during and unto the full end and term of fourteen years from the date of these presents next and immediately ensuing, and fully to be complete and ended: Provided always, that if the said William Edward Wilson shall not, within three days after the granting of these Letters of Registration, register the same in the proper office in the Supreme Court, at Sydney, in the said Colony of New South Wales, then these Letters of Registration, and all advantages whatsoever hereby granted, shall cease and become void.

In witness whereof, I have hereunto set my sign manual, and have caused the present Letters of Registration to be sealed with the seal of the said Colony of New South Wales, at Government House, Sydney, in New South Wales, this ninth day of May, in the year of our Lord one thousand eight hundred and eighty-four.

[L.S.]

AUGUSTUS LOFTUS.

Improved Locomotive Brake.

SPECIFICATION.

SPECIFICATION of EBENEZER BEALS, of Norwich, in the county of Chenango, and State of New Jersey, one of the United States of America, for an invention of an Improved Locomotive Brake.

My invention relates to that class of brakes which are applicable to railway locomotive engines.

The object of my invention is the provision of a brake system for locomotives, which shall secure a uniform and equal pressure of the brake-shoes upon the driving wheels, the shoes being arranged one on either side of each wheel, and which is capable of indefinite extension by simple duplication, so as to operate upon any given number of wheels.

In locomotives the brake pressure cannot be distributed to wheels on both sides of the vehicle through a single line of transmission, as is usual with car-brakes, and as the number of driving-wheels upon a locomotive, on each side, vary from two to four, and all upon a side are rigidly connected longitudinally by connecting-rods and pins, it is evident that an excess of brake-pressure upon one of the said wheels must result in a blow or strain upon the rods and pins; and that, also, if the braking-pressure be not equalized upon opposite sides of each wheel, as well as between all the wheels, its thrust will be opposed to the stress of the connecting-rod, with resultant danger of locking, and consequent flattening of the wheels, and with certainty of unequal wear of boxes and brasses. To avoid these defects, a series of rock-arms or levers, bearing the brake-shoes, are, in the present apparatus, arranged on each side of each of the connected wheels (regardless of the number of the said wheels) and equalizers, and connecting-rods are provided by which to transmit power from a motor or motors longitudinally, and in parallel lines, to each of the two lateral series of wheels, thus distributing the pressure in equal increments to each and every brake-shoe.

In order that my invention may be fully understood, I will describe it with reference to the accompanying drawings, in which fig. 1 is a plan view of a locomotive frame, showing my invention applied on one side thereof; fig. 2 is a side elevation of the same; fig. 3 is an end view thereof; fig. 4 is a side view, illustrating a modification in the way of applying the power; figs. 5, 6, 7, and 8 are views of parts of the mechanism on a larger scale; figs. 9 and 10 are, respectively, a plan and a side view of parts of a tender-frame, showing the connections with the brake-system represented in figs. 1 and 2. A represents a part of the frame of a "Mogul" locomotive; $B B' B''$ are the driving-wheels of a lateral series which, in practice, are connected by rods (not here shown); $b b' b''$ are the axles of the driving-wheels.

Rock-arms C, made in two parts, as shown in fig. 5, are arranged on each side of each driver, and each rock-arm carries a brake-shoe F at its upper end. These shoes F are each swivelled at f upon a bolt or pin, which is to be constructed and adjusted so as to pinch the shoe-lug between two sides cc of the rock-arm, sufficiently to prevent chattering. The rock-arms C are themselves swivelled or fulcrumed each at cc ; in fulcrum-plate DD' , the fulcrum-plates D, located between the wheels, being double-ended, and fulcrum-plates $D'D'$, at the ends, being single-ended. These plates are attached to the frame in any convenient manner. In the detail, fig. 6, the double-plates are shown attached by brackets D'' , while the end plates are bent and bolted to attachments fastened to the frame for the purpose. All these fulcrums are in plane with the centre of the wheel-treads, and are nearer to the vertical planes of the respective axles than are the shoe-fulcrums f . This arrangement, together with the shape of the rock-arms, causes the weight of the shoes and of the equalizer system to aid the withdrawal of the shoes from contact with the wheel-treads. The lower end of each rock-arm is connected by a link h to one end of an equalizer G. The opposite end of each equalizer is connected by a tie H to the corresponding end of the equalizer, upon the opposite side of the same wheel, passing behind the wheel and below the frame. The equalizers that are between the two wheels afford a fulcrum to each other at e .

It will be seen that any desired extension can be given to the system by a simple duplication of parts. The equalizers and ties may be supported from any convenient part of the frame or attachments, by hangers D; but if the link h be beneath, as shown in detail in figs. 7 and 8, no hanger will be necessary, therefore none are shown. A pull from the motor M, applied through suitable intermediate levers NN' to either of the terminal equalizers, the opposite one being anchored to the frame as at g , will effect an application of each brake-shoe of the system, with a pressure exactly equal to that of each of the others. Rods RR connect the levers $N'N'$ with an ordinary brake-system on the running-gear of the tender, as shown in figs. 1, 2, 9, and 10, the levers N' being proportioned to apply the proper relative pressure to the brakes of the locomotive and tender respectively.

It is not necessary that the power should be applied at a terminal. In fig. 4 the invention is shown with a power applied between two central equalizers, with the same effect as that before described. Therefore, I do not confine myself to any special location of motor, nor do I prescribe a special kind of motor, nor am I limited to the use of a single nor yet to a double motor or duplicate motors.

If desired, alternative motors may be used as a steam-cylinder, and a hand-windlass adapted for optional use. The motor cylinder may be placed anywhere in the cab, or under it, on the tender, or at each side of the locomotive, as illustrated in fig. 4, or under the forward part of the boiler—in fact wherever most convenient—since transmitting tire-rods and levers can readily be arranged to transmit motion and pressure from the source of power to the brake-system, as also from the same source of power to the brakes of the tender. The rock-arms in the drawings are all levers of the first order. They, as well as the equalizers, may be of any of the three orders, without affecting the principle of the invention. So, also, power may be transmitted through the ties by thrust as well as by tension. The link h is readily formed by punching or drilling bolt-holes in the ends of a piece of metal of suitable dimension, and giving to said metal between the said holes a quarter or other amount of twist, so as to bring the axis of the said holes at right angles, or at any desired angle, to each other.

Having

Improved Locomotive Brake.

Having thus described my invention, what I claim as new therein, and desire to secure by Letters of Registration is—

First—The combination with the rock-arms of fulcrum-plates attached to the locomotive-frame, and affording centres or fulcrums for the said rock-arms at points in the plane of the wheel-treads, below the horizontal plane of the axles, and nearer their respective vertical planes than are the shoe-centres *f*.

Second—In a locomotive brake, a connected series of brake-shoes, distributed and bearing with self-equalizing pressure, one upon each side of each driving-wheel, and actuated solely by lines of connection passing behind the wheels and below their axles.

In witness whereof, I, the said Ebenezer Beals, have hereto set my hand and seal, this twenty-seventh day of August, one thousand eight hundred and eighty-three.

EBENEZER BEALS,
(By his Agent, Wm. Ed. Wilson).

Witness—

FRED. WALSH,
Manager, Edwd. Waters' Patent Office, Sydney.

This is the specification referred to in the annexed Letters of Registration granted to William Edward Wilson, the ninth day of May, A.D., 1884.

AUGUSTUS LOFTUS.

REPORT.

Sir,

Sydney, 15 September, 1883.

In reply to your B.C. minute of 29th August, enclosing application from Mr. Wm. E. Wilson for Letters of Registration for "An Improved Locomotive Brake," we have to report that we are of opinion that the prayer of such petition might be complied with.

We have, &c.,
JAMES BARNET.
WILLIAM C. BENNETT.

The Under Secretary of Justice.

[Drawings—one sheet.]

Fig. 1.

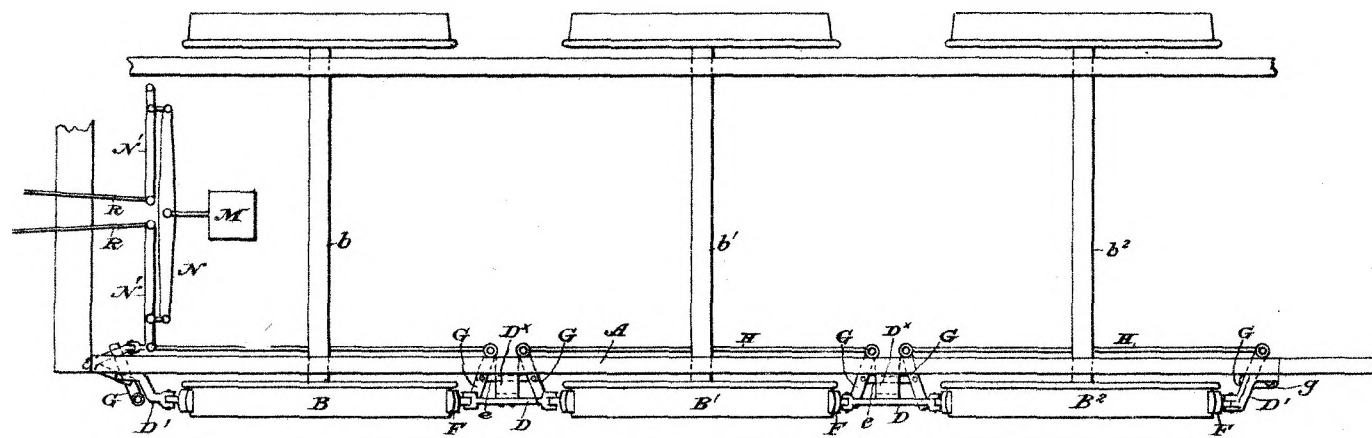


Fig. 2.

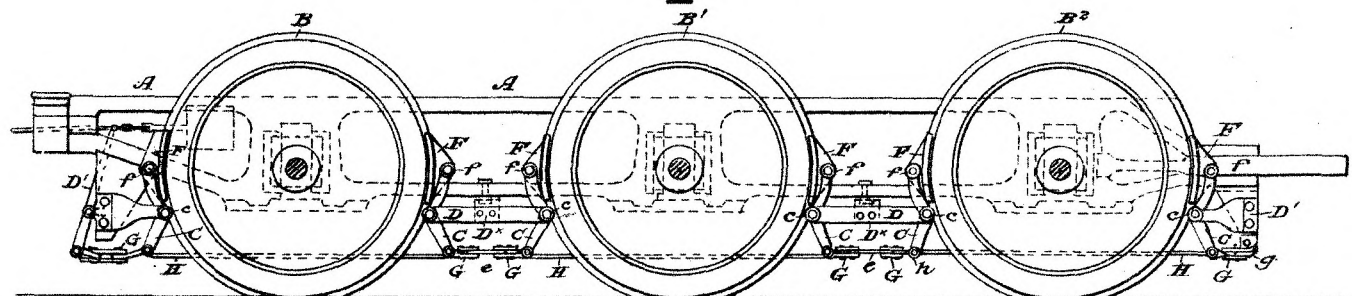


Fig. 3.

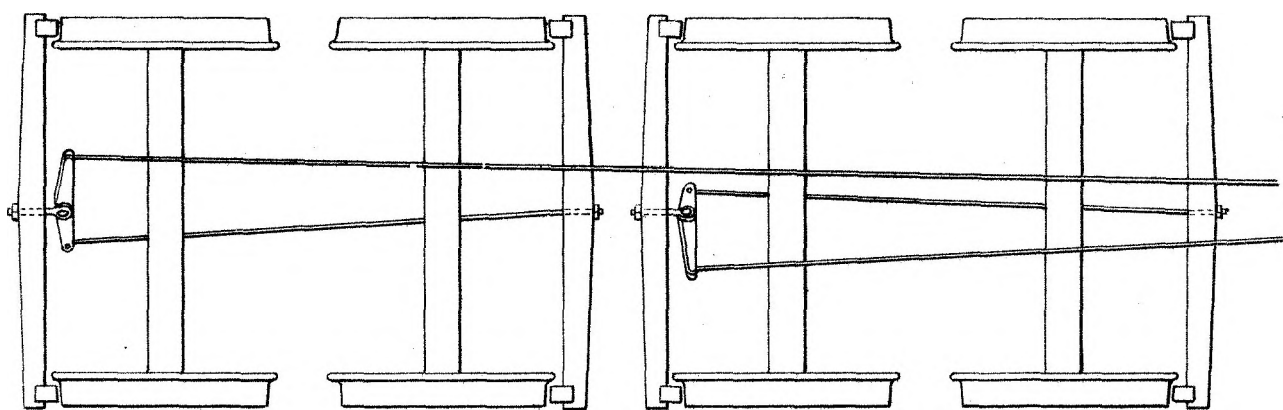


Fig. 10.

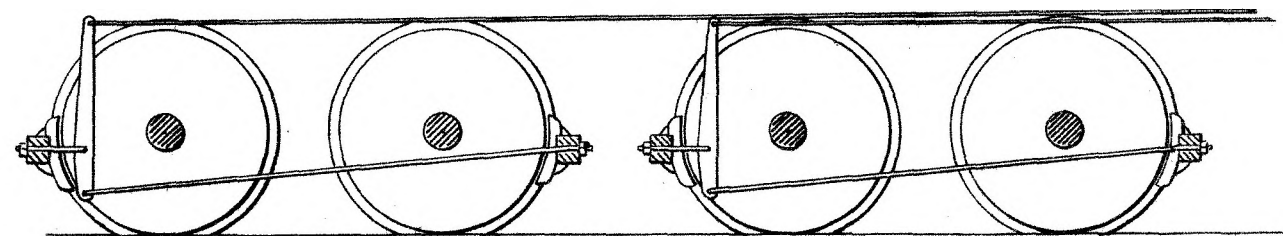


Fig. 3.

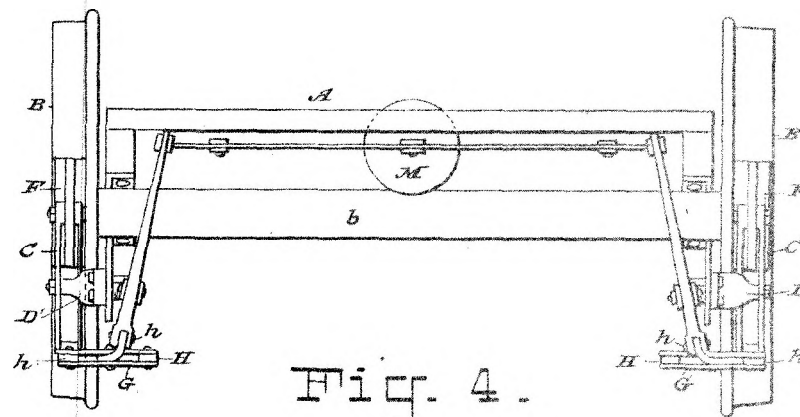


Fig. 4.

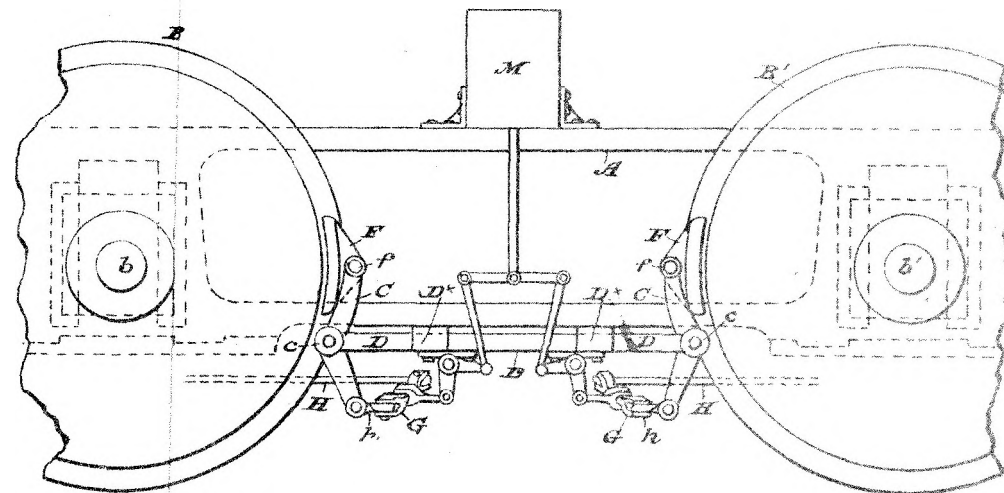


Fig. 5.

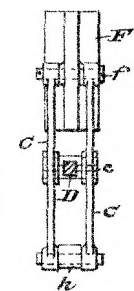


Fig. 7.

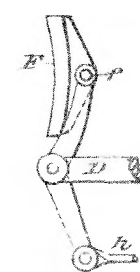


Fig. 6.

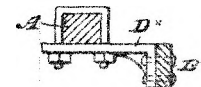


Fig. 8.



(Sig: 245~) This is the Sheet of Drawings referred to in the annexed Letters of Registration, granted to William Edward Wilson, the ninth day of May, A. D., 1884.

Augustus Loftus



A.D. 1884, 9th May. No. 1426.

**IMPROVEMENTS IN OR APPLICABLE TO GAS-FITTINGS, READING-LAMPS, AND
SHADES FOR GAS, &c.**

LETTERS OF REGISTRATION to John James Royle, for Improvements in or applicable to Gas-fittings, Reading-lamps, and Shades for Gas and other Lights, and for supplying Gas to Stoves, and for other purposes.

[Registered on the 10th day of May, 1884, in pursuance of the Act 16 Vic. No. 24.]

BY HIS EXCELLENCY THE RIGHT HONORABLE SIR AUGUSTUS WILLIAM FREDERICK SPENCER LOFTUS (commonly called LORD AUGUSTUS LOFTUS), Knight Grand Cross of the Most Honorable Order of the Bath, a Member of Her Majesty's Most Honorable Privy Council, Governor and Commander-in-Chief of the Colony of New South Wales and its Dependencies.

TO ALL TO WHOM THESE PRESENTS SHALL COME, greeting :

WHEREAS JOHN JAMES ROYLE, of 71, Market-street, Manchester, in England, hath by his Petition humbly represented to me that he is the author or designer of a certain invention or improvement in manufactures, that is to say, of an invention entitled "Improvements in or applicable to gas-fittings, reading-lamps, and shades for gas and other lights, and for supplying gas to stoves, and other purposes," which is more particularly described in the specification and sheet of drawings which are herunto annexed; and that he, the said Petitioner, hath deposited with the Honorable the Treasurer of the said Colony of New South Wales the sum of Twenty Pounds sterling, for defraying the expense of granting these Letters of Registration, as required by the Act of Council, sixteenth Victoria, number twenty-four; and hath humbly prayed that I would be pleased to grant Letters of Registration, whereby the exclusive enjoyment and advantage of the said invention or improvement might be secured to him for a period of fourteen years; and I, being willing to give encouragement to all inventions and improvements in the arts or manufactures which may be for the public good, and having received a report favourable to the prayer of the said Petition, from competent persons appointed by me to examine and consider the matters stated therein and to report thereon for my information, am pleased, with the advice of the Executive Council, and in exercise of the power and authority given to me by the said Act of Council, to grant, and do by these Letters of Registration grant unto the said John James Royle, his executors, administrators, and assigns, the exclusive enjoyment and advantage of the said invention or improvement, for and during the term of fourteen years from the date hereof; to have, hold, and exercise unto the said John James Royle, his executors, administrators, and assigns, the exclusive enjoyment and advantage thereof, for and during and unto the full end and term of fourteen years from the date of these presents next and immediately ensuing, and fully to be complete and ended: Provided always, that if the said John James Royle shall not, within three days after the granting of these Letters of Registration, register the same in the proper office in the Supreme Court, at Sydney, in the said Colony of New South Wales, then these Letters of Registration, and all advantages whatsoever hereby granted, shall cease and become void.

In witness whereof, I have hereunto set my sign manual, and have caused the present Letters of Registration to be sealed with the seal of the said Colony of New South Wales, at Government House, Sydney, in New South Wales, this ninth day of May, in the year of our Lord one thousand eight hundred and eighty-four.

[L.S.]

AUGUSTUS LOFTUS.

Improvements in or applicable to gas-fittings, reading-lamps, and shades for gas, &c.

SPECIFICATION of JOHN JAMES ROYLE, of 71, Market-street, Manchester, in England, mechanical engineer, for an invention entitled "Improvements in or applicable to gas-fittings, reading-lamps, and shades for gas and other lights, and for supplying gas to stoves, and for other purposes."

THE first part of this invention relates to a removable fitting capable of being suspended from the burner of a gas chandelier bracket or other gas-fitting so as to bring down the lighted burner nearer to the table or floor, and which burner being surrounded by a suitable shade or reflector thus diffuses the light where it is most required, and dispenses with the necessity of having so many lights burning in the apartment at the same time. One mode of carrying out my invention is to utilise my improved connection protected by British Letters Patent numbered 2350, and dated the thirteenth day of June, one thousand eight hundred and seventy-nine, for the purpose of making the temporary connection required to the gas-burner, and branching from this joint I arrange a pipe which is turned downwards, and is by preference connected at a lower point with tubular arms or branches which constitute not only the passage for the gas, but also the support for the shade or reflector.

In fig. 1 of the accompanying drawing A is my patent union or connection, seen also in section (on a larger scale) in fig. 2, and as applied to a gas-burner in fig. 3. This union A consists, as described in my former specification, of a metallic box or chamber enclosing at its mouth or opening an India-rubber lip ring *a*, which in this case fits on to the burner *b*, and makes a gas-tight connection therewith. Branching from this union A I arrange a pipe B, which is turned downwards and is by preference connected at a lower point with three tubular arms or branches C, which constitute not only the passage for the gas to the burner D (which being ignited gives the illuminating flame), but also the support for the shade or reflector E, formed of card-board, sheet metal, glass, or other suitable material.

In fig. 4 I illustrate another form of my invention, which only differs from fig. 1 in the number of the arms or branches C, in the shape of the shade or reflector, and in the pipe B being arranged to slide telescopically inside the larger tube B' (through the stuffing-box B²), and thus afford facility for adjusting the height of the light from the table or floor. In this manner I am enabled to make a connection to the gas-burner without removing the gas-globe, as the upper part or union A of the apparatus is capable of being inserted between the gallery and the globe, as seen in figs. 3 and 4, and the union A being then drawn down over the burner the apparatus becomes suspended, and a perfectly gas-tight joint is effected.

I wish it to be understood that any other suitable joint might be substituted and applied to my improved fitting for connecting the apparatus to the burner. It will be readily apparent that the same description of fitting is suitable for supporting a candle or other lamp or light from an existing gas-fitting,—say, for instance, an oil-lamp in which the reservoir of oil would be situated at a point above the junction of the tubular arms C with the pipe B, and that one or more of the tubular arms C could form the passage of the oil down to the wick or burner of the lamp, which would in this case be substituted for the gas-burner D; or an electric light, either alone or in combination with gas, and with or without a globe or shade, could be supported in a similar manner.

In fig. 5 I illustrate a modification of my present invention as applicable to making a connection to the burner of a gas-fitting without necessarily removing the globe for supplying gas to reading-lamps, stoves, and for other lighting or heating purposes by means of an India-rubber or other flexible tube affixed in the ordinary manner to the tail piece F.

In figs. 6 and 7 I illustrate a front and side view respectively of a further modification of my invention applied to the purpose of supporting and heating a vessel H containing water or other liquid or food, and beneath which is a gas-burner J, which being lighted thus constitutes a food-warming apparatus suitable specially for infants' or invalids' food, or which vessel H may partake of the form of a kettle or other like contrivance, or may be used for heating glue-kettles, and for other analogous purposes. In this arrangement it will be obvious that when the vessel H is removed (by lifting it out of the supporting platform I), the gas-burner J could be used for illuminating purposes, whilst being turned down such burner serves the purpose of a night-light, and constitutes an adjustable means of keeping the contents of the vessel H at any desired temperature.

In fig. 8 I represent my invention as applied to a gas-pressure gauge for indicating the pressure of gas, and consisting of the union A with the pipe L connecting the same with the ordinary glass U tube M, and thus affording a ready means of temporarily connecting such gauge to any gas-burner (without necessarily removing the globe), and so to ascertain the pressure of the gas supply.

Having thus particularly described and ascertained the nature of this my said invention, together with the best methods with which I am acquainted for carrying the same into practical effect, I wish it to be distinctly understood that I do not confine myself to the precise details, relative proportions, or dimensions of the various parts of the improved apparatus hereinbefore described and illustrated in the accompanying drawing, as the same may be considerably varied without departing from the invention, but what I claim is—

First—The combination of my improved union forming the subject matter of British Letters Patent, No. 2350, A.D. 1879, or other suitable joint with the apparatus hereinbefore described, for connecting and bringing down or suspending a light from the burner of an existing gas-fitting nearer to the table or floor, substantially as and for the purposes hereinbefore described and illustrated in the accompanying drawing.

Second—The adaptation of my improved union as aforesaid to the purpose of connecting gas-pressure gauges, India-rubber or other flexible tubing, to gas-burners without necessarily removing the globe from the gas-fitting, substantially as and for the purposes hereinbefore described and illustrated in the accompanying drawing.

In witness whereof, I, the said John James Royle, have hereto set my hand and seal, this eighteenth day of March, one thousand eight hundred and eighty-four.

Witness—

FRED. WALSH,
Manager, E. Waters' Patent Office, Sydney.

JOHN J. ROYLE,
(By his Agent, BASIL G. WOOLLEY).

This is the specification referred to in the annexed Letters of Registration granted to John James Royle, the 9th day of May, A.D. 1884.

AUGUSTUS LOFTUS.

REPORT

Improvements in or applicable to gas-fittings, reading-lamps, and shades for gas, &c.

REPORT.

Sir, We do ourselves the honor to report, in reply to your blank cover of the 20th instant, transmitting John James Royle's Petition for the registration of "Improvements in or applicable to gas-fittings, reading-lamps, and shades for gas and other lights, and for supplying gas to stoves, and for other purposes," that we are of opinion the prayer of the petitioner may be granted in terms of his specification, drawings, and claim.

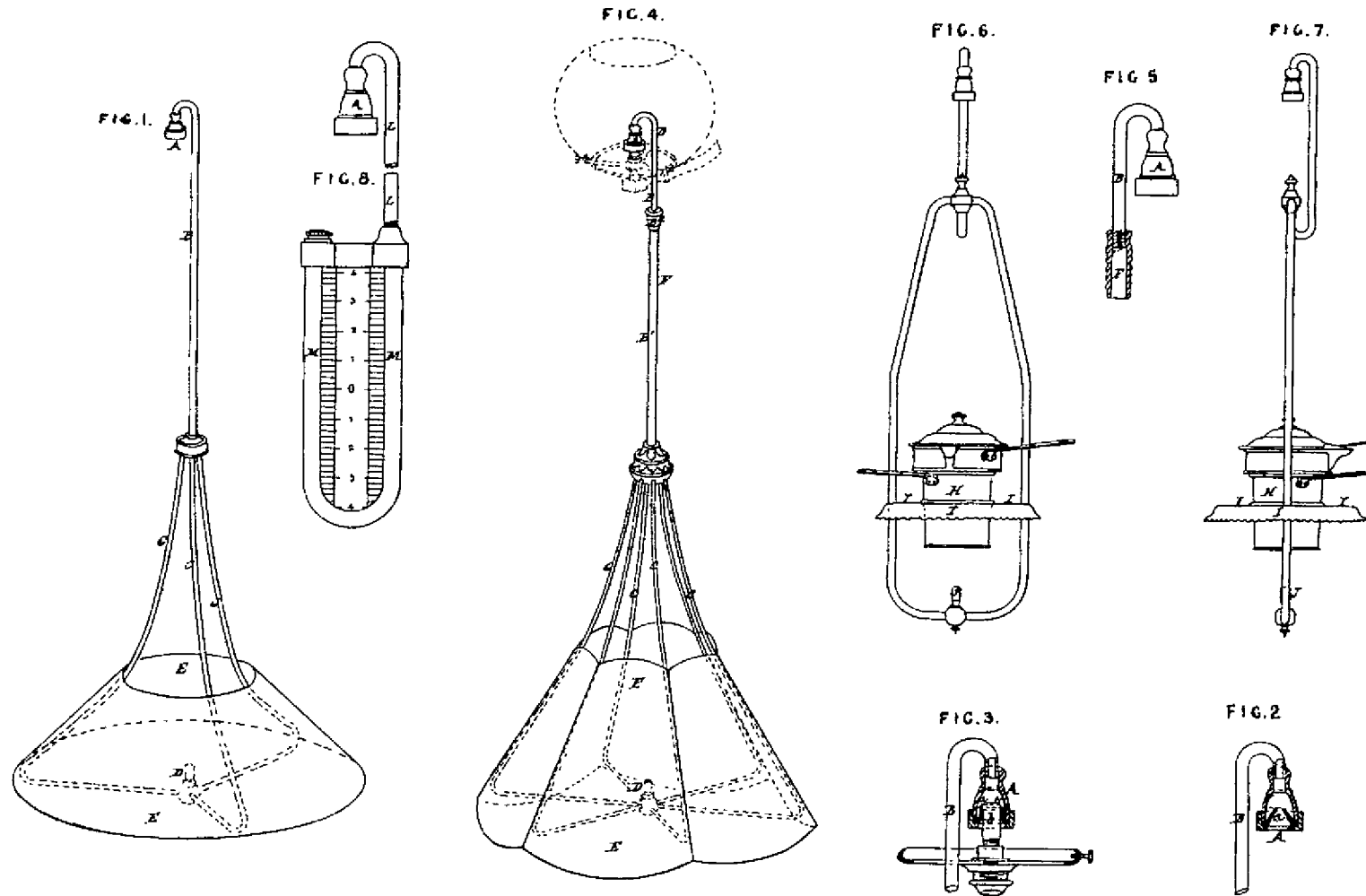
The Under Secretary of Justice.

Sydney, 25 March, 1884.

We have, &c.,

E. C. CRACKNELL.
GOTHEK K. MANN.

[Drawings—one sheet.]



This is the Sheet of Drawings referred to in the annexed Letters of Registration, granted to John James Royle, the ninth day of May, A. D. 1884. Augustus Loftus.

(Sig: 245-)



A.D. 1884, 9th May. No. 1427.

IMPROVEMENTS IN DRYING APPARATUS.

LETTERS OF REGISTRATION to John Forsyth Johnstone, for Improvements in Drying Apparatus, applicable especially for drying all kinds of waste animal fish or other matter.

[Registered on the 10th day of May, 1884, in pursuance of the Act 16 Vic. No. 24.]

BY HIS EXCELLENCY THE RIGHT HONORABLE SIR AUGUSTUS WILLIAM FREDERICK SPENCER LOFTUS (commonly called LORD AUGUSTUS LOFTUS), Knight Grand Cross of the Most Honorable Order of the Bath, a Member of Her Majesty's Most Honorable Privy Council, Governor and Commander-in-Chief of the Colony of New South Wales and its Dependencies.

TO ALL TO WHOM THESE PRESENTS SHALL COME, greeting :

WHEREAS JOHN FORSYTH JOHNSTONE, of Brooksby Chemical Works, Bow Common Lane, in the county of Middlesex, England, chemical and manure manufacturer, hath by his Petition humbly represented to me that he is the author or designer of a certain invention or improvement in manufactures, that is to say, of an invention entitled "Improvements in Drying Apparatus, applicable especially for drying all kinds of waste animal fish or other matter," which is more particularly described in the specification and the sheet of drawings which are hereunto annexed ; and that he, the said Petitioner, hath deposited with the Honorable the Treasurer of the said Colony of New South Wales the sum of Twenty Pounds sterling, for defraying the expense of granting these Letters of Registration, as required by the Act of Council, sixteenth Victoria, number twenty-four ; and hath humbly prayed that I would be pleased to grant Letters of Registration, whereby the exclusive enjoyment and advantage of the said invention or improvement might be secured to him for a period of fourteen years : And I, being willing to give encouragement to all inventions and improvements in the arts or manufactures which may be for the public good, and having received a report favourable to the prayer of the said Petition, from competent persons appointed by me to examine and consider the matters stated therein and to report thereon for my information, am pleased, with the advice of the Executive Council, and in exercise of the power and authority given to me by the said Act of Council, to grant, and do by these Letters of Registration grant unto the said John Forsyth Johnstone, his executors, administrators, and assigns, the exclusive enjoyment and advantage of the said invention or improvement, for and during the term of fourteen years from the date hereof ; to have, hold, and exercise unto the said John Forsyth Johnstone, his executors, administrators, and assigns, the exclusive enjoyment and advantage thereof, for and during and unto the full end and term of fourteen years from the date of these presents next and immediately ensuing, and fully to be complete and ended : Provided always, that if the said John Forsyth Johnstone shall not, within three days after the granting of these Letters of Registration, register the same in the proper office in the Supreme Court, at Sydney, in the said Colony of New South Wales, then these Letters of Registration, and all advantages whatsoever hereby granted, shall cease and become void.

In witness whereof, I have hereunto set my sign manual, and have caused the present Letters of Registration to be sealed with the seal of the said Colony of New South Wales, at Government House, Sydney, in New South Wales, this ninth day of May, in the year of our Lord one thousand eight hundred and eighty-four.

[L.S.]

AUGUSTUS LOFTUS.

Improvements in Drying Apparatus.

SPECIFICATION of JOHN FORSYTH JOHNSTONE, of Brooksby Chemical Works, Bow Common Lane, in the county of Middlesex, England, chemical and manure manufacturer, for an invention entitled "Improvements in Drying Apparatus, applicable especially for drying all kinds of waste animal fish or other matter."

THE object of my invention is mainly to construct drying apparatus in such a manner that waste animal fish or other matter can be dried without allowing any noxious vapours to escape into the outside atmosphere, and at a much less cost than has hitherto been done; the apparatus is, however, applicable for drying a great variety of other substances.

The apparatus consists of a shallow pan, made of iron, steel, or other metal, having around its lower part a jacket for holding high-pressure steam, or other heating medium. The top of the pan is closed over by covering plates, through which is an opening, at which the material to be operated upon may be placed into the pan; an outlet pipe is also led away from the top of the pan for conveying away vapours. The waste material is kept in motion during the drying process by agitators, fixed to a central upright shaft. Each agitator is formed of a curved metal blade extending horizontally from the shaft, with its lower edge as near as possible to the bottom of the pan; a series of curved flat-bladed springs are also secured to the agitators; their ends scrape the bottom of the pan just in rear of the agitators, and by them the whole bottom surface of the pan is continuously scraped over. From the bottom of the pan is also an outlet passage carried downwards through the steam-jacket. Whilst the apparatus is in operation this passage is closed by a door, the top of which comes on a level with the surface of the bottom of the pan. When the material has been dried the door is opened and the dried material is allowed to pass out through the outlet passage.

The drawings annexed show a machine constructed according to my invention.

Figure 1 is a plan of the machine with the cover plates removed, and also part of the wheel by which the axis of the agitator is revolved.

Figure 2 is a side elevation of the machine.

Figure 3 is a section on the line AB in figure 1.

Figure 4 is a plan showing the covers, but with the driving gear removed.

Figure 5 is a cross-section on a larger scale taken through that part of the bottom of the pan at which the outlet door is situated.

Figures 6 and 7 show two elevations taken at right angles to one another of the lower part of the agitator axis.

Figure 8 shows in elevation the lower part of the agitator axis and one of the agitators.

Figure 9 is a cross-section of the agitator taken on the line AB, figure 8; and

Figure 10 is a cross-section of the agitator taken on the line CD, figure 8.

aaa is a circular pan, with a flange extending outwards all around it; the flange rests upon the top of another flanged pan *bbb*, which is of a larger diameter (see figures 2 and 3); both pans I make, by preference, of cast iron. The inner pan does not extend to the bottom of the outer pan, so that a space *c* is left between the two pans, around the sides and at the bottom. This space forms a steam-jacket, to which steam at high pressure, superheated steam, or other heating medium, such as hot air, is supplied, for the purpose of heating the inner pan and drying any material which may be placed in it. The steam or other heating medium may be supplied through a pipe connected to any convenient part of the bottom of the pan *b*. On the underside of the bottom of the pan *a* are projections *a'* to rest on the bottom of the larger pan *b*, and bolts *b'* are passed through the bottom of the pan *b* into these projections, so as to bolt together the bottoms of the two pans, and allow of steam at a pressure of say 60 to 80 lb. to the inch being supplied to the space between them. The top of the pan *a* is closed over by covering plates *f*; the edges of the plates are bolted down to the top flange of the pan *a* and to a strong girder *m*, which is fixed across the top of the pan. Where the plates abut one against the other the aperture between them is covered by a bar secured to the underside of one of the plates, or the side edges of the plates may be made to overlap one another, in the manner shown at figure 11. In this way the pan is closed over in an air-tight manner, or nearly so.

The substance to be dried is fed into the inner pan *a* through an opening *e* in one of the top covering-plates *f* (see figures 3 and 4); this opening is, as shown, provided with a suitable cover, by which it can be closed during the drying operation. *g* are the agitators shown in figures 1, 2, and 3; they extend horizontally from a vertical axis *h*, to which a slow revolving motion is imparted. The agitators just clear the side and bottom of the pan; they are formed of a metal plate curved in the manner shown at figure 1, and fixed at one end to a lug or projection *h'*, which stands out from the axis *h*, whilst the opposite end is bent upwards at right angles, and is, at its extremity, bolted to one end of a connecting rod *h''*, which rod at its other end is fixed to the extremity of a radial arm *h'''*, which stands out from the axis, as seen in figures 1 and 8. The connecting rod serves to drag round the outer end of the agitator whenever the axis is revolved. The lugs *h'* and agitator blade *g* are, as shown, inclined at an angle to the bottom of the pan; the material scraped up in front of the agitator escapes backwards over its upper edge, and so, after being lifted by the agitator, drops down behind it. The agitators also carry a series of curved flat-bladed springs *pppp* (see figures 1, 3, 8, 9, and 10). The springs are riveted to a bar *g'*, which is itself bolted to the agitator blade by bolts *g''*. The springs form a series of scrapers which scrape over the whole of the bottom of the pan; that portion of the bottom of the pan not scraped over by the scrapers carried by one agitator blade being scraped over by the scrapers carried by the other agitator blade. Each spring scraper is also somewhat twisted, so that its scraping edge is not radial to the axis, but is somewhat inclined to a radial line, in order that the matters scraped up by it may be moved inwards towards the axis, and pass through the spaces between the scrapers instead of being carried forward in front of them. When the scrapers become worn or unserviceable the bolts *g''* are unscrewed; the bar *g'* can then be taken off, and another one, similarly carrying a set of spring scrapers, be put on instead of it.

The vertical spindle *h*, in figures 1, 2, 3, is driven by a worm wheel *i*, seen in figures 1, 2, 3; this is firmly fixed on the vertical spindle *h*, and engages a worm *j* on the horizontal shaft *k* (see figures 1, 2, 3). The vertical spindle *h* works in a bearing carried by the strong girder *m* fixed across the top of the pan *a*, and at the bottom of the pan the spindle takes its bearing in a step *n*, or otherwise. The

Improvements in Drying Apparatus.

The worm *j* is free to turn on the horizontal shaft *k*, but can be locked to it by a clutch *k*¹, which can be slid endwise along the shaft, and when moved into position to lock the worm to the shaft can be secured to the shaft by a locking screw-bolt *k*². Usually I prolong the shaft *k*, so that the agitators of two, three, or more machines ranged in a row may, in like manner, be driven from it, whilst any one or other of them can be put out of operation whenever desired, by setting the worm *j*¹, which drives its agitator free from the shaft *k*, and allowing the shaft to revolve within it without turning the worm. Any number of rows of machines may likewise be erected in lines parallel with one another, and the shafts *k* which transmit motion to the axes of their agitators all be driven from one driving, shaft *l*, mounted at right angles to them. Motion may be transmitted to each of the shafts *k* from the main driving shaft *l* by suitable gearing such as shown at *l*¹, or by belting, or by other suitable means.

When the matter in any one machine has been dried to a proper condition it is let out from the machine through a door or trap *o* at the bottom of the under pan *bbb*. This door, as will be seen at figures 1 and 2, is made to open downwards on a hinge joint *o*¹. When the door is closed it fills up a passage *c*¹, formed through the steam space *c*, and its top comes level with the bottom of the pan *a*. The steam evaporated from the material during the process of drying is led off or exhausted out of the machine through a pipe *g* secured to an opening in the cover, and, if necessary, may be condensed or otherwise rendered innocuous.

Having thus described the nature of my invention, and the manner of performing the same, I would have it understood that I claim—

First—The combination of the pan *a*, steam-jacket *c* surrounding the sides and bottom of pan, passage *c*¹ leading through steam-jacket *c*, door *o*, for closing this passage, cover plates *f*, axis *h*, agitators *g*, carrying spring scrapers *p*, substantially as described.

Second—The combination of the pan *a* surrounding pan *b*, distance pieces *a*¹, bolts *b*¹, passage *c*¹ leading down through steam space *c*, door *o*¹, for closing this passage, cover plates *f* for closing over the top of pan *a*, exhaust or outlet passage *g*, axis *h*, agitators *g*, carrying spring scrapers *p*, substantially as described.

Third—The combination of the pan *a*, the surrounding pan *b*, the distance pieces *a*¹, bolts *b*¹, passage *c*¹, door *o*, cover plates *f*, outlet passage *c*¹, axis *h*, and agitators *g*, substantially as described.

In witness whereof, I, the said John Forsyth Johnstone, have hereunto set my hand and seal, this nineteenth day of January, 1884.

JOHN F. JOHNSTONE.

This is the specification referred to in the annexed Letters of Registration granted to John Forsyth Johnstone, the ninth day of May, A.D. 1884.

AUGUSTUS LOFTUS.

REPORT.

Sir,

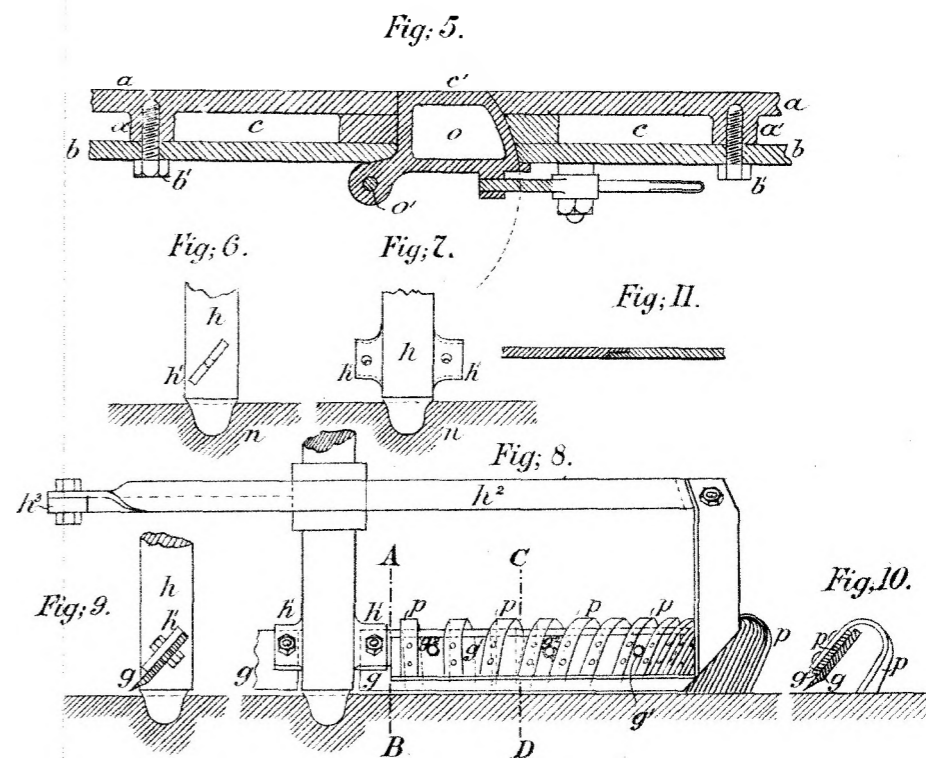
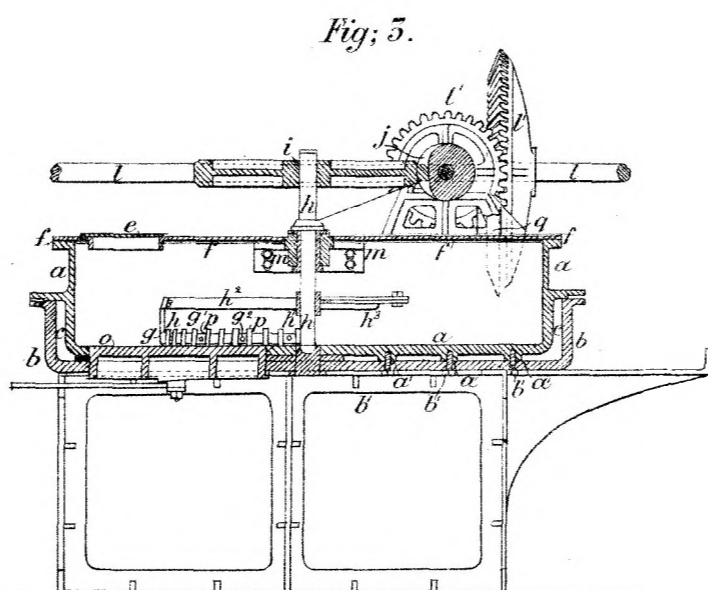
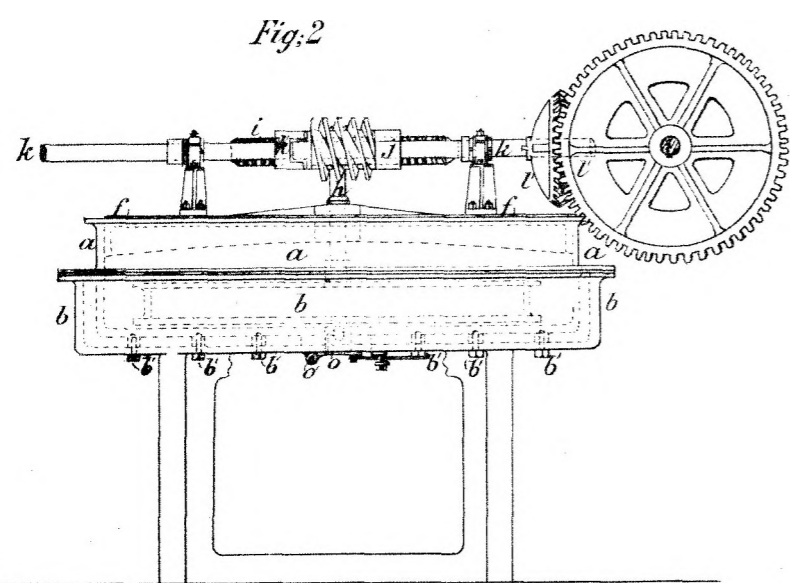
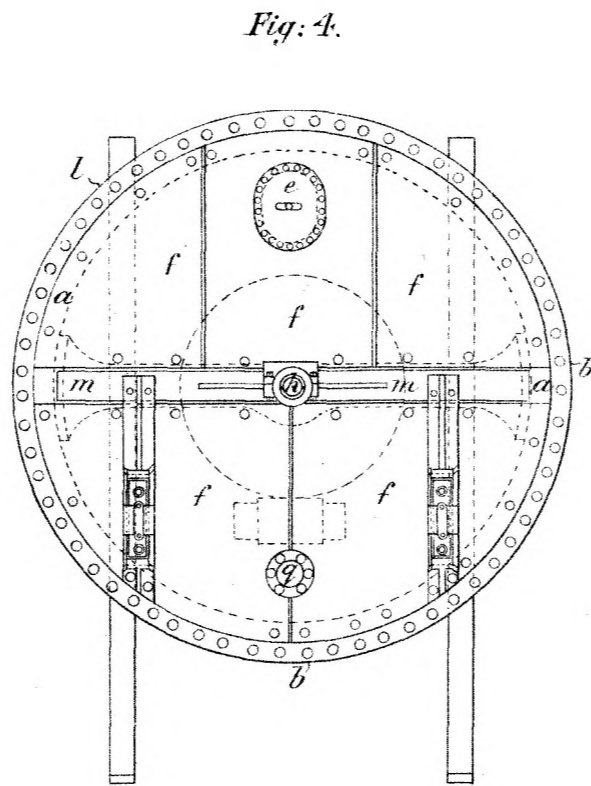
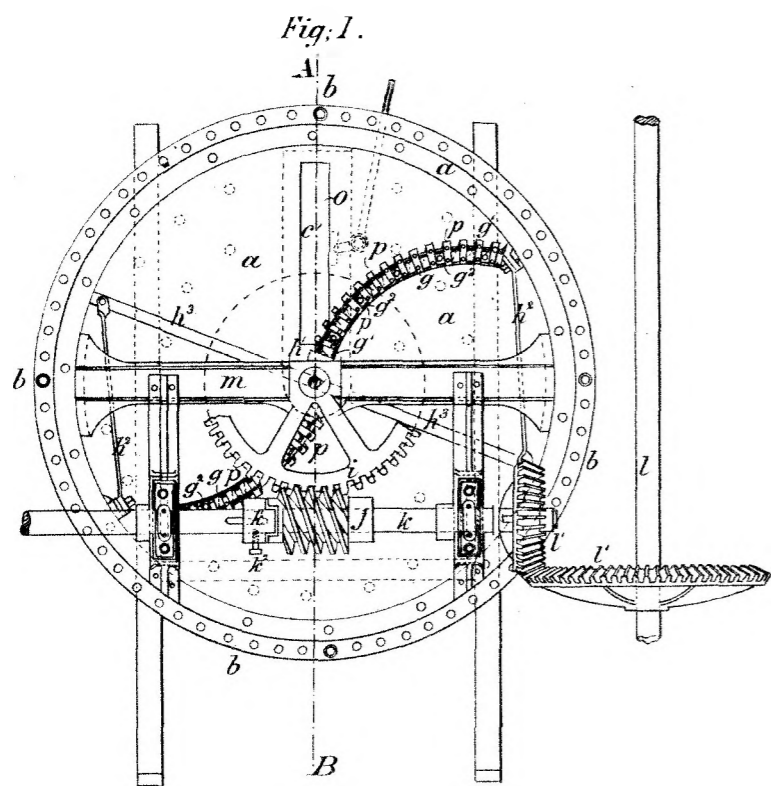
The petition of Mr. John Forsyth Johnstone for Letters of Registration for an invention entitled "Improvements in Drying Apparatus, applicable especially for drying all kinds of waste animal fish or other matter," having been referred to us, we have examined the specification and drawings accompanying the same, and have the honor to report that we see no objection to the granting of said petition in accordance with specification, drawings, and claim.

Sydney, 24 March, 1884.

We have, &c.,
J. SMITH.
A. LEIBIUS.

The Under Secretary of Justice.

[Drawings—one sheet.]



This is the Sheet of Drawings referred to in the annexed Letters of Registration granted to John Forsyth Johnstone, the Ninth day of May, A. D., 1884.
Augustus Loftus.



A.D. 1884, 9th May. No. 1428.

IMPROVEMENTS IN SUGAR-CANE MILLS.

LETTERS OF REGISTRATION to Duncan Stewart for Improvements in
Sugar-cane Mills.

[Registered on the 10th day of May, 1884, in pursuance of the Act 16 Vic. No. 24.]

BY HIS EXCELLENCY THE RIGHT HONORABLE SIR AUGUSTUS WILLIAM FREDERICK SPENCER LOFTUS (commonly called LORD AUGUSTUS LOFTUS), Knight Grand Cross of the Most Honorable Order of the Bath, a Member of Her Majesty's Most Honorable Privy Council, Governor and Commander-in-Chief of the Colony of New South Wales and its Dependencies.

TO ALL TO WHOM THESE PRESENTS SHALL COME, greeting :

WHEREAS DUNCAN STEWART, of Glasgow, in the county of Lanark, Scotland, engineer, hath by his Petition humbly represented to me that he is the author or designer of a certain invention or improvement in manufactures, that is to say, of an invention entitled "Improvements in Sugar-cane Mills," which is more particularly described in the specification and sheet of drawings which are hereunto annexed ; and that he, the said Petitioner, hath deposited with the Honorable the Treasurer of the said Colony of New South Wales the sum of Twenty Pounds sterling, for defraying the expense of granting these Letters of Registration, as required by the Act of Council, sixteenth Victoria, number twenty-four ; and hath humbly prayed that I would be pleased to grant Letters of Registration, whereby the exclusive enjoyment and advantage of the said invention or improvement might be secured to him for a period of fourteen years : And I, being willing to give encouragement to all inventions and improvements in the arts or manufactures which may be for the public good, and having received a report favourable to the prayer of the said Petition, from competent persons appointed by me to examine and consider the matters stated therein and to report thereon for my information, am pleased, with the advice of the Executive Council, and in exercise of the power and authority given to me by the said Act of Council, to grant, and do by these Letters of Registration grant unto the said Duncan Stewart, his executors, administrators, and assigns, the exclusive enjoyment and advantage of the said invention or improvement, for and during the term of fourteen years from the date hereof ; to have, hold, and exercise unto the said Duncan Stewart, his executors, administrators, and assigns, the exclusive enjoyment and advantage thereof, for and during and unto the full end and term of fourteen years from the date of these presents next and immediately ensuing, and fully to be complete and ended : Provided always, that if the said Duncan Stewart shall not, within three days after the granting of these Letters of Registration, register the same in the proper office in the Supreme Court, at Sydney, in the said Colony of New South Wales, then these Letters of Registration, and all advantages whatsoever hereby granted, shall cease and become void.

In witness whereof, I have hereunto set my sign manual, and have caused the present Letters of Registration to be sealed with the seal of the said Colony of New South Wales, at Government House, Sydney, in New South Wales, this ninth day of May, in the year of our Lord one thousand eight hundred and eighty-four.

[L.S.]

AUGUSTUS LOFTUS.

Improvements in Sugar-cane Mills.

TO ALL TO WHOM THESE PRESENTS SHALL COME: I, DUNCAN STEWART, of Glasgow, in the county of Lanark, Scotland, send greeting:

WHEREAS I am desirous of obtaining Letters of Registration for the Colony of New South Wales, securing unto me Her Majesty's special license, that I, my executors, administrators, and assigns, and such others as I or they should at any time agree with, and no others, should and lawfully might from time to time and at all times during the term of fourteen years next and immediately after the date of the said Letters of Registration make, use, exercise, and vend, within the said Colony of New South Wales, an invention for "Improvements in Sugar-cane Mills": And whereas, in order to obtain such Letters of Registration, I must, by an instrument or specification in writing under my hand and seal, particularly describe and ascertain the nature of the said invention, and in what manner the same is to be performed.

Now, know ye, that the nature of the said invention, and the manner in which the same is to be performed, is particularly described and ascertained in and by the following statement in writing, reference being had to the accompanying drawings, that is to say:

My said invention has for its objects to render sugar-cane mills less liable to breakage or injury from careless or irregular feeding, and to provide convenient means for adjusting or regulating the pressure of the rolls. My invention consists in holding the rolls in position by improved appliances capable of yielding on the occurrence of excessive strains instead of being rigid or unyielding as formerly. I apply my invention to a mill of the well known three-roller class, the bearing-caps of the upper or middle roll being held down in the usual way, whilst the two lower rolls are pressed horizontally inwards by the rams of hydraulic cylinders, the rams acting on the bearing-blocks, which are fitted on horizontal guide-beds. The hydraulic cylinders are held in their places by rods or long bolts passing horizontally and completely through the housings or headstocks, a pair of such rods or long bolts, one above and the other below the bearing, serving for the two lower bearings in each housing. The hydraulic cylinders are supplied with water, or other suitable liquid under pressure, from an accumulator loaded to a suitable pressure. When strains occur, corresponding to a greater pressure than that for which the accumulator is loaded, the rams yield, and breakage is avoided; and to give a still greater elasticity of action and sensitiveness, air-vessels are fitted in connection with the hydraulic cylinders. The lower rolls being thus liable to horizontal movement, it is necessary to provide means to keep the edge of what is known as the "returner" in contact with that one of the lower rolls between which and the middle roll the canes are first passed. For this purpose the ends of the returner have adjustably fixed to them links or bars which are curved to pass without frictional contact over the journals of the roll, and are attached to the bearing-blocks, so that the returner moves with the blocks, and in consequence its edge keeps close to the roll.

And, in order that my said invention and the manner of performing the same may be properly understood, I herewith append a sheet of explanatory drawings, to be hereinafter referred to, and representing a sugar-cane mill, as constructed or fitted with my improvements.

In the accompanying drawings fig. 1 is a sectional end elevation, and fig. 2 is a side elevation. Figs. 3 and 4 are vertical and horizontal sections, explanatory of the returner details. In these drawings the same reference numerals are used to mark the same or like parts wherever they are repeated.

The framing consists, as usual, of a pair of massive housings or headstocks 5 fixed on a bed-plate 6, and it carries three rolls 7, 8, 9, the middle one 8 being partly between and partly above the other two, which are at the same level. The upper or middle roll 8 is held in ordinary bearings, the caps 10 of which are held down in the usual way. The lower rolls 7, 9, are held on bearing-blocks 11, which are fitted to slide on horizontal guide-beds 12, and which are pressed inwards by the rams 13 of hydraulic cylinders 14. These cylinders 14 are formed with collars or lugs 15, by means of which they are fixed to the framing, and they are securely held by nuts 16 screwed on the ends of horizontal rods or long bolts 17 passing completely through the housings 5 and through the lugs 15, and transmitting the horizontal strains between the opposite cylinders. The cylinders 14 are supplied with water or other suitable liquid under pressure by branch pipes 18, leading it from a suitably loaded accumulator; and near each cylinder there is connected to its pipe an air-vessel 19, the air in which renders the relieving action quicker when sudden strains occur.

The returner 20 which guides the canes round under the middle roller 8 rests and is movable on the upper horizontal surface of a bearer 21, fixed in openings in the housings 5, and the returner is made with ends 22, which project through the same openings, and which have curved bars or links 23 attached to them. These links 23 are curved to pass without frictional contact over the roller journals 24, and they are formed with eyes at their outer ends to be set on studs or projecting pins formed on the bearing-blocks 11 or on the heads of the rams 13, which bear against the blocks 11. The inner ends of the links 23 are screwed and passed through holes in the returner ends 22, to which they are adjustably fixed by screw-nuts at each side.

Having thus particularly described my said invention, and the manner of performing the same, I have to state that I do not restrict myself to the precise details herein described or delineated, but that what I believe to be novel and original, and claim as the invention which I desire to secure by Letters of Registration, is:—

Claims—

1. Three rolls, of which two are at one level and the third above and between the others, the said third roll being held in ordinary immovable bearings, and the two lower rolls in bearings which are pressed horizontally inwards by the rams of cylinders supplied with liquid of a definite or limited pressure, substantially as and for the purposes set forth.
2. The combination of air-vessels with hydraulic cylinders by which pressure is applied to the lower rolls of sugar-cane mills, substantially as and for the purposes set forth.
3. The combination of rods or long bolts with hydraulic cylinders, by which pressure is applied to the lower rolls, the said rods or long bolts passing through the housings and connecting the cylinders at opposite parts thereof, substantially as and for the purposes set forth.

FIG. 1.

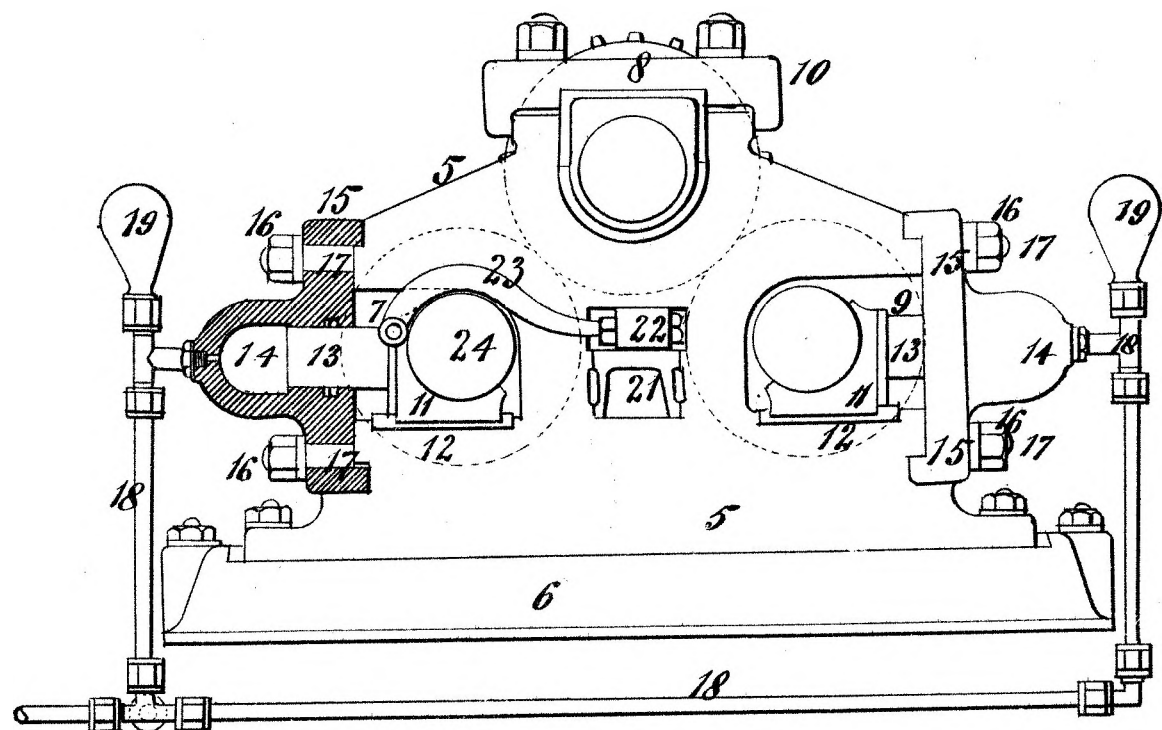


FIG. 2.

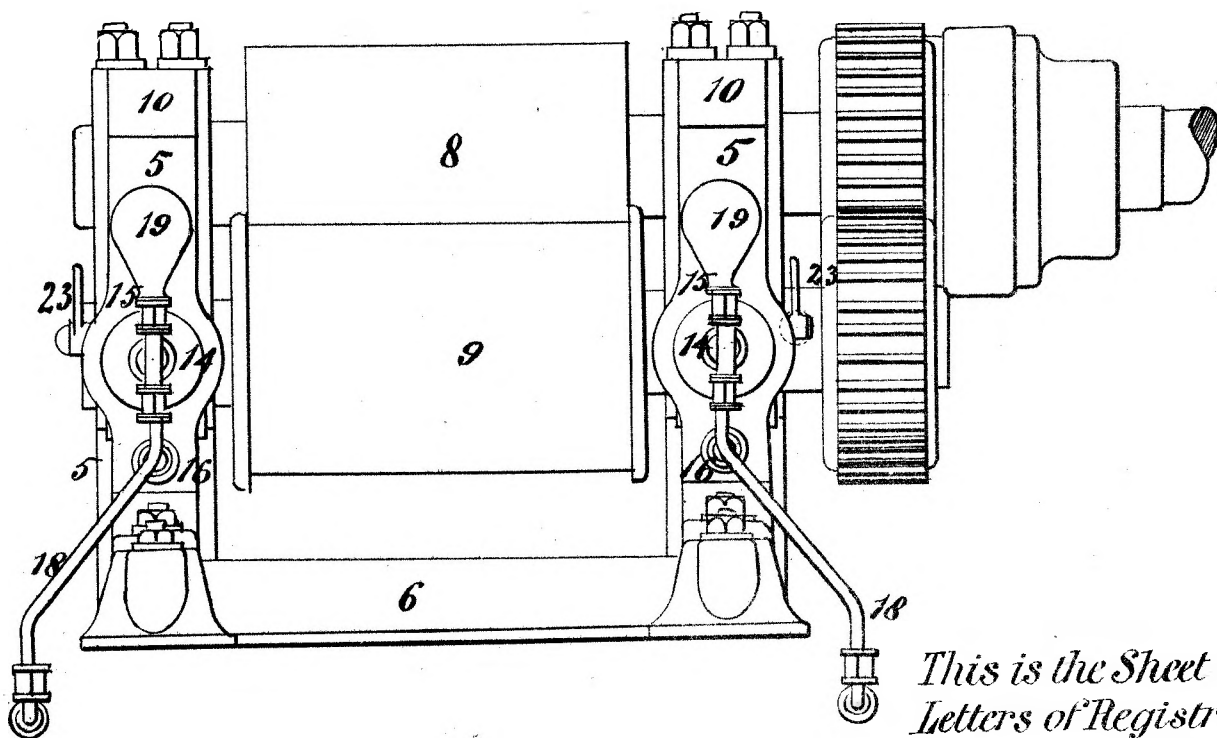


FIG. 3.

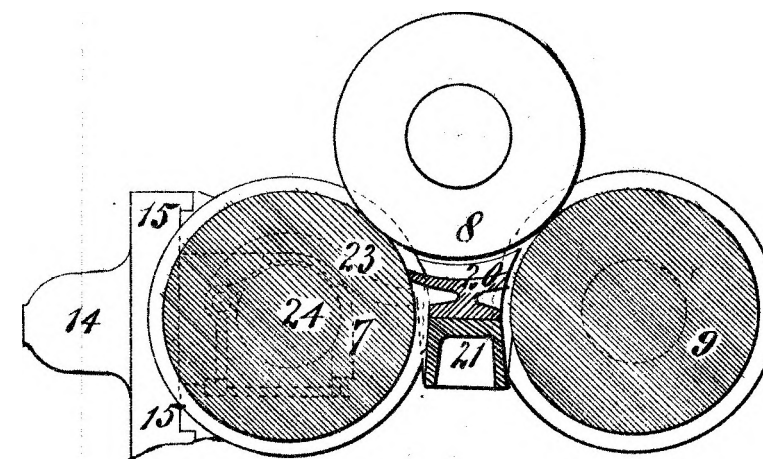
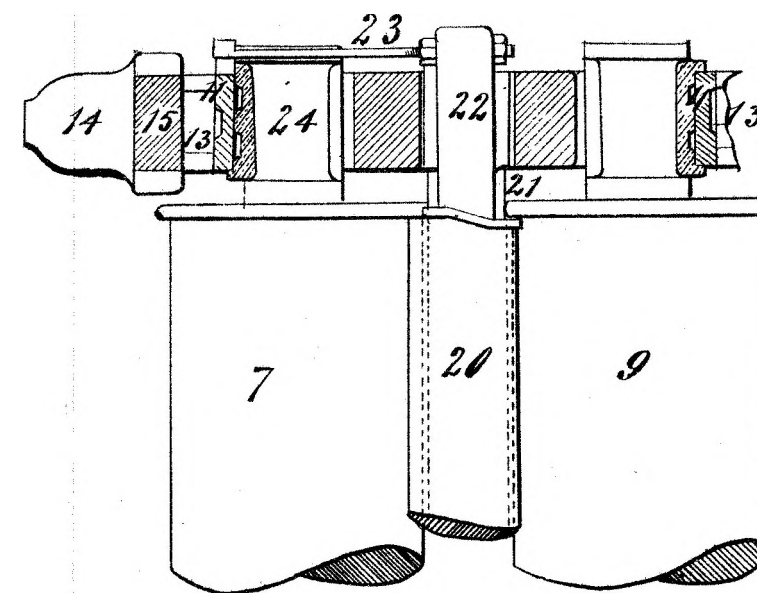


FIG. 4.



This is the Sheet of Drawings referred to in the annexed
 Letters of Registration, granted to Duncan Stewart, the
 ninth day of May, A.D., 1884. *Augustus Loftus.*

Duncan Stewart

(Sig: 245~)



A.D. 1884, 9th May. No. 1429.

A WEDGE-SHAPED CIGARETTE.

**LETTERS OF REGISTRATION to Soloman De Beer and Louis Henry Hart,
for a Wedge-shaped Cigarette.**

[Registered on the 10th day of May, 1884, in pursuance of the Act 16 Vic. No. 24.]

BY HIS EXCELLENCY THE RIGHT HONORABLE SIR AUGUSTUS WILLIAM FREDERICK SPENCER LOFTUS (commonly called LORD AUGUSTUS LOFTUS), Knight Grand Cross of the Most Honorable Order of the Bath, a Member of Her Majesty's Most Honorable Privy Council, Governor and Commander-in-Chief of the Colony of New South Wales and its Dependencies.

TO ALL TO WHOM THESE PRESENTS SHALL COME, greeting :

WHEREAS SOLOMAN DE BEER and LOUIS HENRY HART, trading under the style or firm of "De Beer, Hart, & Company," of Clarence-street, Sydney, in the Colony of New South Wales, cigar manufacturers, have by their Petition humbly represented to me that they are the assignees of Louis Ludzki, of Sydney aforesaid, cigarette maker, who is the author or designer of a certain invention or improvement in manufactures, that is to say, of an invention entitled "A Wedge-shaped Cigarette," which is more particularly described in the specification and the sheet of drawings which are hereunto annexed ; and that they, the said Petitioners, have deposited with the Honorable the Treasurer of the said Colony of New South Wales the sum of Twenty Pounds sterling for defraying the expense of granting these Letters of Registration, as required by the Act of Council, sixteenth Victoria, number twenty-four ; and have humbly prayed that I would be pleased to grant Letters of Registration whereby the exclusive enjoyment and advantage of the said invention or improvement might be secured to them for a period of fourteen years : And I, being willing to give encouragement to all inventions and improvements in the arts or manufactures which may be for the public good, and having received a report favourable to the prayer of the said Petition from competent persons appointed by me to examine and consider the matters stated therein and to report thereon for my information, am pleased, with the advice of the Executive Council, and in exercise of the power and authority given to me by the said Act of Council, to grant, and do by these Letters of Registration grant unto the said Soloman De Beer and Louis Henry Hart, their executors, administrators, and assigns, the exclusive enjoyment and advantage of the said invention or improvement, for and during the term of fourteen years from the date hereof ; to have, hold, and exercise unto the said Soloman De Beer and Louis Henry Hart, their executors, administrators, and assigns, the exclusive enjoyment and advantage thereof, for and during and unto the full end and term of fourteen years from the date of these presents next and immediately ensuing, and fully to be complete and ended : Provided always, that if the said Soloman De Beer and Louis Henry Hart shall not, within three days after the granting of these Letters of Registration, register the same in the proper office in the Supreme Court, at Sydney, in the said Colony of New South Wales, then these Letters of Registration, and all advantages whatsoever hereby granted, shall cease and become void.

In witness whereof, I have hereunto set my sign manual, and have caused the present Letters of Registration to be sealed with the seal of the said Colony of New South Wales, at Government House, Sydney, in New South Wales, this ninth day of May, in the year of our Lord one thousand eight hundred and eighty-four.

[L.S.]

AUGUSTUS LOFTUS.

A Wedge-shaped Cigarette.

SPECIFICATION by LEWIS LUDZKI, of Sydney, in the Colony of New South Wales, cigarette maker, of the invention of a Wedge-shaped Cigarette.

I, THE above-named Lewis Ludzki, do hereby declare the nature of my said invention of a wedge-shaped cigarette, the particulars thereof, and in what manner the same is to be constructed, to be particularly described and ascertained in and by the following statement, reference being made to the sheet of drawings hereunto annexed.

The said invention consists of an improved form of cigarette, constructed in the shape of a wedge, either round or flattened, as shown in figure 1 of the annexed drawings, the end of the cigarette intended for lighting being thicker than any other portion of the cigarette throughout the length thereof, and the cigarette tapering throughout its length towards the other end intended for the mouth, at which end the cigarette is thinner than at any other portion of its length.

The said invention of a wedge-shaped cigarette has for its object to secure in cigarettes a uniform flavour and taste, or an approximation thereto throughout the entire cigarette during the progress of smoking, which is effected by the new and improved form given to the cigarette. And for the following reasons: 1. A cigarette has strength and flavour in proportion to its thickness, a thick cigarette having more strength and flavour than a thin cigarette of the same tobacco. 2. After a cigarette or cigar is smoked for a portion of its length, the chemical ingredients of the tobacco, liberated by the burning thereof, pass through the unsmoked portion of the cigarette or cigar by suction, or in the form of smoke, and impart a fuller flavour and give a stronger or different taste to the unsmoked portion. And the nearer the cigarette or cigar is burned towards the mouth the fuller it becomes in flavour and in taste. This is the case to a greater extent with cigarettes than cigars, the tobacco of the cigarette being generally fresher and containing more moisture than the leaf of the cigar. This difference in flavour and taste is entirely avoided in the wedge-shaped cigarette. As it tapers gradually towards the mouth, the end intended for the mouth being about one-third the size of the end intended for lighting, the difference in the quantity of tobacco would of itself give an increase of mildness or decrease of flavour as the cigarette is smoked, which allows for the increase in flavour and taste obtained in the process of smoking, as hereinbefore mentioned, the latter being in effect moderated by the form of the cigarette.

The improved form of cigarette hereinbefore described is constructed or manufactured by me by cutting ordinary cigarette-paper into the shape which will form a wedge when rolled up, the shape and size of the paper used by me being shown in figure 2 of the annexed drawings, and being in dimensions one inch and eleven-sixteenths across one end for the lower portion of the cigarette, and one inch across the other end, and being two and three quarter inches long in the centre of the paper, but the same can of course be of any size. The paper being laid flat, the tobacco is placed thereon in the same way as is done for the making of an ordinary round cigarette, except that a larger quantity of tobacco must be placed at the end intended for the thick portion of the cigarette, and the quantity of tobacco gradually lessened towards the other end. The cigarette is then rolled by the hand in the ordinary way, and in the same manner as in the manufacture of a round cigarette by hand. I use the ordinary appliance of a piece of stout paper or cloth laid on the table upon which the open cigarette-paper with the tobacco laid thereon is placed, the whole being rolled up together until the tobacco is even. The edges are secured by me with a gum-stick, that is a thin piece of stick wetted with gum placed alongside.

I do not claim as my invention, or any part thereof, the mode in which the said cigarette is made by me, as hereinbefore mentioned, the same being the ordinary way in which a round cigarette is made.

But I claim as my invention the application of the said wedge shape to cigarettes as an improved form of cigarette, with the advantage attaching thereto hereinbefore set forth.

In witness whereof, I, the said Lewis Ludzki, have hereunto set my hand, this sixteenth day of January, one thousand eight hundred and eighty-four.

LEWIS LUDZKI.

Signed by the said Lewis Ludzki, in the presence of—

RICHARD J. HANSON,
Clerk to A. De Lissa, Solicitor, Sydney.

This is the specification referred to in the annexed Letters of Registration granted to Solomon De Beer and Louis Henry Hart, the ninth day of May, A.D. 1884.

AUGUSTUS LOFTUS.

REPORT.

Sir,

Having examined the specification and plan accompanying the petition of Messrs. De Beer, Hart, & Co., for an invention entitled "A Wedge-shaped Cigarette," we are of opinion that the prayer of the petitioner may be granted.

Sydney, 5 February, 1884.

We have, &c.,
THOS. RICHARDS.
JAMES BARNET.

The Under Secretary of Justice.

This

A Wedge-shaped Cigarette.

This is the Sheet of Drawings referred to in the annexed specification under my hand, bearing date the sixteenth day of January, one thousand eight hundred and eighty-four.

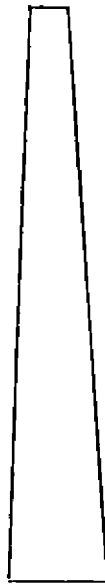
LEWIS LUDZKI.

Fig:1



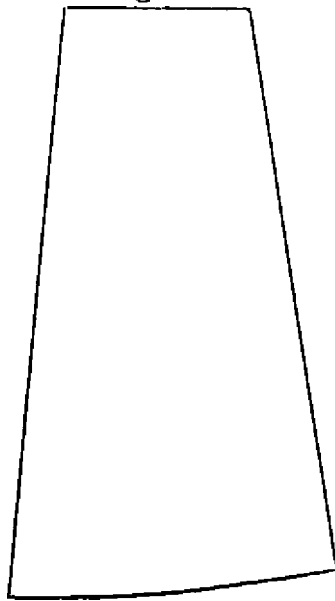
Round

Fig:1.



Flat.

Fig:2.



This is the Sheet of Drawings referred to in the annexed Letters of Registration granted to Soloman De Beer and Lewis Henry Hart, the ninth day of May, A.D, 1884.

AUGUSTUS LOFTUS.



A.D. 1884, 27th May. No. 1430.

**IMPROVEMENTS IN EXTRACTING COBALT, NICKEL, AND MANGANESE FROM
THEIR ORES.**

**LETTERS OF REGISTRATION to John Clark, for Improvements in extracting
Cobalt, Nickel, and Manganese from their Ores.**

[Registered on the 29th day of May, 1884, in pursuance of the Act 16 Vic. No. 24.]

By HIS EXCELLENCY THE RIGHT HONORABLE SIR AUGUSTUS WILLIAM FREDERICK SPENCER LOFTUS (commonly called LORD AUGUSTUS LOFTUS), Knight Grand Cross of the Most Honorable Order of the Bath, a Member of Her Majesty's Most Honorable Privy Council, Governor and Commander-in-Chief of the Colony of New South Wales and its Dependencies.

TO ALL TO WHOM THESE PRESENTS SHALL COME, greeting :

WHEREAS JOHN CLARK, of Glasgow, in the county of Lanark, Scotland, hath by his Petition humbly represented to me that he is the author or designer of a certain invention or improvement in manufactures, that is to say, of an invention entitled "Improvements in extracting Cobalt, Nickel, and Manganese from their Ores," which is more particularly described in the specification which is hereunto annexed; and that he, the said Petitioner, hath deposited with the Honorable the Treasurer of the said Colony of New South Wales the sum of Twenty Pounds sterling, for defraying the expense of granting these Letters of Registration, as required by the Act of Council, sixteenth Victoria, number twenty-four; and hath humbly prayed that I would be pleased to grant Letters of Registration, whereby the exclusive enjoyment and advantage of the said invention or improvement might be secured to him for a period of fourteen years: And I, being willing to give encouragement to all inventions and improvements in the arts or manufactures which may be for the public good, and having received a report favourable to the prayer of the said Petition, from competent persons appointed by me to examine and consider the matters stated therein and to report thereon for my information, am pleased, with the advice of the Executive Council, and in exercise of the power and authority given to me by the said Act of Council, to grant, and do by these Letters of Registration grant unto the said John Clark, his executors, administrators, and assigns, the exclusive enjoyment and advantage of the said invention or improvement, for and during the term of fourteen years from the date hereof; to have, hold, and exercise unto the said John Clark, his executors, administrators, and assigns, the exclusive enjoyment and advantage thereof, for and during and unto the full end and term of fourteen years from the date of these presents next and immediately ensuing, and fully to be complete and ended: Provided always, that if the said John Clark shall not, within three days after the granting of these Letters of Registration, register the same in the proper office in the Supreme Court, at Sydney, in the said Colony of New South Wales, then these Letters of Registration, and all advantages whatsoever hereby granted, shall cease and become void.

In witness whereof, I have hereunto set my sign manual, and have caused the present Letters of Registration to be sealed with the seal of the said Colony of New South Wales, at Government House, Sydney, in New South Wales, this twenty-seventh day of May, in the year of our Lord one thousand eight hundred and eighty-four.]

AUGUSTUS LOFTUS.

Improvements in extracting Cobalt, Nickel, and Manganese from their Ores.

TO ALL TO WHOM THESE PRESENTS SHALL COME: I, JOHN CLARK, of Glasgow, in the county of Lanark, Scotland, send greeting:

WHEREAS I am desirous of obtaining Letters of Registration for the Colony of New South Wales, securing unto me Her Majesty's Special License that I, my executors, administrators, and assigns, and such others as I or they should at any time agree with, and no others, should and lawfully might from time to time, and at all times, during the term of fourteen years next and immediately after the date of the said Letters of Registration, make, use, exercise, and vend within the said Colony of New South Wales an invention for "Improvements in extracting Cobalt, Nickel, and Manganese from their Ores." And whereas in order to obtain such Letters of Registration I must, by an instrument or specification in writing under my hand and seal, particularly describe and ascertain the nature of the said invention, and in what manner the same is to be performed: Now, know ye, that the nature of the said invention, and the manner in which the same is to be performed, is particularly described and ascertained in and by the following statement in writing, that is to say—

My said invention has for its object the extraction of cobalt, nickel, and manganese from their ores by improved and economical processes, and an important feature of my invention is the utilisation and advantageous application of protochloride of iron, which is a residual or waste product obtained in the extraction of copper. My invention also comprises other advantageous features.

In carrying out my invention, protochloride of iron in solution, and obtained as a residual product or otherwise, is added to the ore, which is in a ground state, and either calcined or uncalcined. The mixture is boiled down to dryness, and the dry mass is next put into a muffle or reverberatory furnace, and is heated to a temperature by preference not exceeding 700 degrees Fahrenheit, but so as to decompose the protochloride of iron and separate the iron in the form of an insoluble oxide, and without decomposing the chlorides of cobalt, nickel, and manganese. This part of the process is to be stopped whenever hydrochloric acid ceases to come off in quantity. The hydrochloric acid is recovered by condensation and absorption by water in the usual way,

The next part of the process consists in dissolving out the chlorides of cobalt, nickel, and manganese, with water, and in subsequently heating the solution to boiling temperature, and adding a soluble sulphide of calcium in just sufficient quantity to precipitate the sulphides of cobalt and nickel, leaving the manganese in solution. If any iron or alumina is found in the solution it should be precipitated with carbonate of lime or dolomite, and separated before heating the solution. After separating the precipitated sulphides of cobalt and nickel, lime is added to precipitate the manganese, which can be converted into a higher oxide by any of the known processes.

My improved process is specially applicable for treating ores of the kind obtained in New Caledonia; and in the case of such ores, containing, for example, 26 parts per cent. of oxides of manganese, 3 parts per cent. of oxide of cobalt, and 1 part per cent. of oxide of nickel, the quantity of protochloride of iron to be used will be as much as contains 60 parts per cent. of iron. The precise proportions may, however, be varied in different cases.

Having thus particularly described my said invention, and the manner of performing same, I have to state that what I claim is the combination of processes hereinbefore described, the essential features being—1, the application of the protochloride of iron; 2, the separation of the iron by heating and driving off the hydrochloric acid; and 3, the precipitating of the sulphides of cobalt and nickel by means of sulphide of calcium.

In witness whereof, I, the said John Clark, have hereunto set my hand and seal, this twenty-first day of February, in the year of our Lord one thousand eight hundred and eighty-four.

JOHN CLARK.

Signed and sealed in the presence of—

EDMUND HUNT, witness.

DAVID FERGUSON, witness.

This is the specification referred to in the annexed Letters of Registration granted to John Clark, the 27th day of May, A.D. 1884.

AUGUSTUS LOFTUS.

REPORT.

Sir,

The application of Mr. John Clark for Letters of Registration for "Improvements in extracting Cobalt, Nickel, and Manganese from their Ores," having been referred to us, we have examined the specification accompanying the same, and have now the honor to report that we see no objection to the issue of Letters of Registration as prayed for.

Sydney, 19 April, 1884.

We have, &c.,
J. SMITH.
A. LEIBIUS.

The Under Secretary of Justice.



A.D. 1884, 27th May. No. 1431.

IMPROVEMENTS IN FLUSHING TANKS, &c.

LETTERS OF REGISTRATION to William Bartholomew, for Improvements in flushing tanks or vessels for receiving water or liquid, and, when full, automatically discharging it.

[Registered on the 29th day of May, 1884, in pursuance of the Act 16 Vic. No. 24.]

BY HIS EXCELLENCY THE RIGHT HONORABLE SIR AUGUSTUS WILLIAM FREDERICK SPENCER LOFTUS (commonly called LORD AUGUSTUS LOFTUS), Knight Grand Cross of the Most Honorable Order of the Bath, a Member of Her Majesty's Most Honorable Privy Council, Governor and Commander-in-Chief of the Colony of New South Wales and its Dependencies.

TO ALL TO WHOM THESE PRESENTS SHALL COME, greeting :

WHEREAS WILLIAM BARTHOLOMEW, of Messrs. Doulton & Co., sanitary engineering works, Albert Embankment, Lambeth, in the county of Surrey, England, hath by his Petition humbly represented to me that he is the author or designer of a certain invention or improvement in manufactures, that is to say, of an invention entitled "Improvements in flushing tanks or vessels for receiving water or liquid, and, when full, automatically discharging it," which is more particularly described in the specification and the sheet of drawings which are hereunto annexed ; and that he, the said Petitioner, hath deposited with the Honorable the Treasurer of the said Colony of New South Wales the sum of Twenty Pounds sterling, for defraying the expense of granting these Letters of Registration, as required by the Act of Council, sixteenth Victoria, number twenty-four ; and hath humbly prayed that I would be pleased to grant Letters of Registration, whereby the exclusive enjoyment and advantage of the said invention or improvement might be secured to him for a period of fourteen years : And I, being willing to give encouragement to all inventions and improvements in the arts or manufactures which may be for the public good, and having received a report favourable to the prayer of the said Petition, from competent persons appointed by me to examine and consider the matters stated therein and to report thereon for my information, am pleased, with the advice of the Executive Council, and in exercise of the power and authority given to me by the said Act of Council, to grant, and do by these Letters of Registration grant unto the said William Bartholomew, his executors, administrators, and assigns, the exclusive enjoyment and advantage of the said invention or improvement for and during the term of fourteen years from the date hereof ; to have, hold, and exercise unto the said William Bartholomew, his executors, administrators, and assigns, the exclusive enjoyment and advantage thereof, for and during and unto the full end and term of fourteen years from the date of these presents next and immediately ensuing, and fully to be complete and ended : Provided always, that if the said William Bartholomew shall not, within three days after the granting of these Letters of Registration, register the same in the proper office in the Supreme Court, at Sydney, in the said Colony of New South Wales, then these letters of Registration, and all advantages whatsoever hereby granted, shall cease and become void.

In witness whereof, I have hereunto set my sign manual, and have caused the present Letters of Registration to be sealed with the seal of the said Colony of New South Wales, at Government House, Sydney, in New South Wales, this twenty-seventh day of May, in the year of our Lord one thousand eight hundred and eighty-four.

[L.S.]

AUGUSTUS LOFTUS.

Improvements in Flushing Tanks, &c.

SPECIFICATION of WILLIAM BARTHOLOMEW, of Messrs. Doulton & Co.'s Sanitary Engineering Works, Albert Embankment, Lambeth, in the county of Surrey, England, for an invention entitled "Improvements in flushing tanks or vessels for receiving water or liquid, and, when full, automatically discharging it."

THIS invention has for its object improvements in flushing tanks or vessels for receiving water or liquid, and, when full, automatically discharging it.

For this purpose I employ a receiving vessel or tank having a pipe or passage ascending through the bottom, and formed into a siphon, with its mouth at a short distance from the bottom of the tank. Below the bottom of the tank, the siphon pipe already mentioned terminates in a trumpet mouth, and it dips down into a box or receptacle from which there is an outlet leading (in the case of a flushing tank) to a drain or to other place where it is required that the liquid should be delivered. This outlet is so placed that the trumpet end of the siphon pipe is immersed to some depth in liquid contained in the box or receptacle.

If the entrance of the liquid into the receiving vessel be intermittent, the apparatus will be operative without any further appliance. The siphon action is set up when the tank or receiving vessel is full by the escape of air from the siphon pipe.

In consequence of the mouth of the siphon pipe dipping into the liquid in the box or receptacle, and the trumpet-like form given to the mouth, the escape of air from the siphon pipe takes place intermittently, a considerable quantity of air passing away at a time sufficient to start the flow.

If the entrance of the liquid to the receiving vessel or tank be always slow, it is advisable, in order to ensure efficient action, to provide a vent from the siphon pipe by a passage sealed by a trap offering less resistance to the escape of air than is offered by the liquid covering its mouth. The rise of the liquid in the receiving vessel or tank then compresses the air in the siphon tube, until the vent is opened by the liquid being forced out of its trap. The air then freely escapes from the siphon, and is replaced by an inflow of liquid which starts the siphon's action. To recharge the trap upon the air vent, a small pocket is provided, from which liquid gradually descends into it.

In order that the vent may not be forced at too early a period, I also provide an orifice by which air can for a time escape freely from the siphon pipe, but this orifice after a time becomes covered by the rise of the liquid in the receiving vessel or tank.

Thus, in this apparatus (which has no moving parts) the discharge is determined by the disturbance of equilibrium resulting from the sudden escape of a considerable quantity of air, and not by the sudden inrush of liquid to the cistern or receiving vessel, or by the operation of the liquid in the cistern or floats, or moving mechanism, as in other flushing tanks of this class.

And in order that my said invention may be fully understood, and readily carried into effect, I will proceed to describe the drawings hereunto annexed.

DESCRIPTION OF THE DRAWINGS.

Figure 1 is a vertical section of the flushing apparatus in its simpler form.

Figure 2 shows a like apparatus, but different in the detail of construction.

Figure 3 is an underside view of one limb of the siphon pipe.

Figure 4 is a section of the same.

Figure 5 shows another modification of figure 1.

Figure 6 shows the apparatus, with additions, to meet the case of a very slow entry of liquid to the receiving vessel or tank.

Figure 7 shows to a larger scale a detail of figure 6.

In figure 1 the siphon is formed by means of a bell inverted over an upright pipe. *a* is a receiving vessel or tank of metal or pottery-ware. *b* is the portion within the tank of an ascending pipe. *b*¹ is the part of this pipe below the bottom of the tank *a*; it also terminates in a trumpet mouth. *b*² is a bell inverted over *b*, and completing the siphon. This bell is supported with its mouth at a short distance from the bottom of the tank, so that there is a free passage beneath it. *d* is a box or receptacle below the tank *a*, into which the pipe *b*¹ dips. The outlet *e* is situated some distance above the bottom of the receptacle *d* so that water always remains in the receptacle *d*, and into this water the pipe *b*¹ dips.

Figure 2 shows the apparatus in another form, the pipe *b* itself being bent downwards, in place of being covered by a bell. Its trumpet-mouth is channelled in the manner illustrated by the figures 3 and 4, which are respectively an underside view and a section of the lower end of this pipe. These channels prevent the end of the pipe becoming uncovered. This is of importance where the tank *a* receives fat from a sink which should not be allowed to pass at once into the drain. The fat floats on the water, and remains in the tank.

The channels in the mouth of the bell admit air to the siphon pipe to recharge it.

Figure 5 shows another form in which the fat or other floating matter is kept back by an outer bell or cylinder *f*, open above and below, and this then serves as a support for the bell *b*².

Figure 6 shows the apparatus as arranged to meet the case of a very slow entry of liquid to the receiving vessel or tank *a*. The parts *a*, *b*, *b*¹, *b*², *d*, and *e* are as in figure 1. *f* is a tube forming a communication between the interior and the exterior of the siphon pipe; it is bent at its lower end to a U form, and this bend, becoming full of liquid, forms a trap somewhat less deep than the immersion of the lower end of *b*¹ in the box or receptacle *d*, and as the receiving vessel or tank *a* falls the liquid is blown out of the bend in the pipe *f* before it can escape from the mouth of the siphon pipe. *g* is also a small tube providing an escape of air from the siphon; it terminates at its upper end above the level to which the liquid rises in the vessel *a*, so that it is not liable to be stopped by floating bodies. The open lower end of this tube is so placed that the liquid may rise nearly to the top of the pipe *b* before the pressure causes the tube *f* to become untrapped.

By this arrangement, however slow the inflow at a given point, the pressure within the siphon is suddenly relieved, liquid rushes in, and the siphon-like action is set up. The

Improvements in Flushing Tanks, &c.

The bend of the tube *f* becomes refilled during the delivery from the receiving vessel or tank *a*, but in some cases the suction might again empty it; I therefore provide upon it in the pocket *f'*, shown to a larger scale at figure 7. This pocket catches a portion of the liquid during the outward rush, and allows it gradually to descend into the trap after the siphon-like action has ceased.

Having thus described the nature of my said invention, and the manner of performing the same, I would have it understood that I claim as my improvements in flushing tanks or vessels for receiving water or liquid, and, when full, automatically discharging it—

First—The combination of the receiving vessel or tank, the siphon, and the box or receptacle containing liquid, into which the lower limb of the siphon dips, substantially as described.

Second—In an automatic flushing apparatus, the combination of the receiving vessel or tank, the siphon with the trumpet-like mouth at its lower end, and the box or receptacle containing liquid, into which the said mouth of the siphon dips, substantially as described.

Third—The combination with the receiving vessel or tank, the siphon, and the box or receptacle containing liquid, into which the lower end of the siphon dips, of the trapped vent passage *f*, operating substantially as described.

In witness whereof, I, the said William Bartholomew, have hereunto set my hand and seal, this twenty-eighth day of January, 1884.

WILLIAM BARTHOLOMEW.

This is the specification referred to in the annexed Letters of Registration granted to William Bartholomew, the 27th day of May, A.D. 1884.

AUGUSTUS LOFTUS.

REPORT.

Sir,

In reply to your B.C. of 17th instant, forwarding a petition from Mr. William Bartholomew, of Lambeth, London, for Letters of Registration for an invention entitled "Improvements in flushing tanks or vessels for receiving water or liquid, and, when full, automatically discharging it," we have the honor to inform you, that, having examined the plans and specifications accompanying the application, we are of opinion that the prayer of the Petitioner should be acceded to.

Sydney, 26 March, 1884.

We have, &c.,
JOHN WHITTON.
E. O. MORIARTY.

The Under Secretary of Justice.

[Drawings—one sheet.]

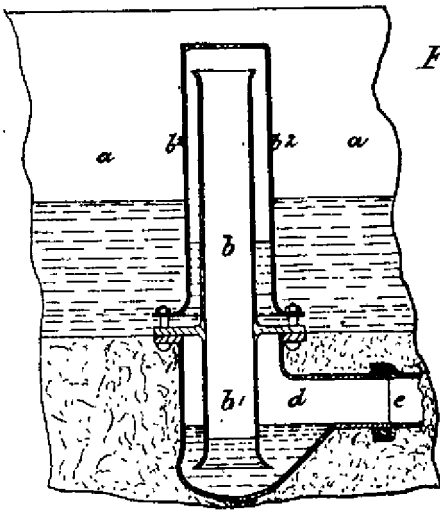


Fig. 1.

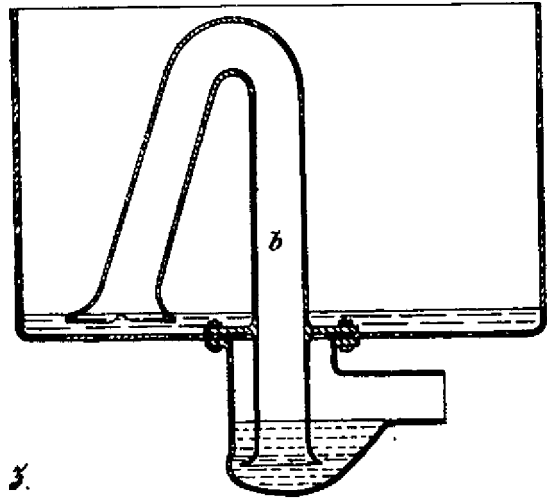


Fig. 2.

Fig. 5.

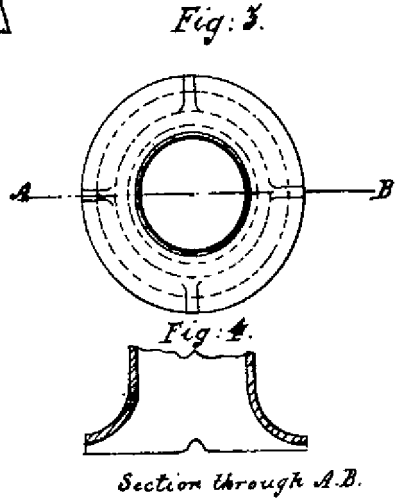
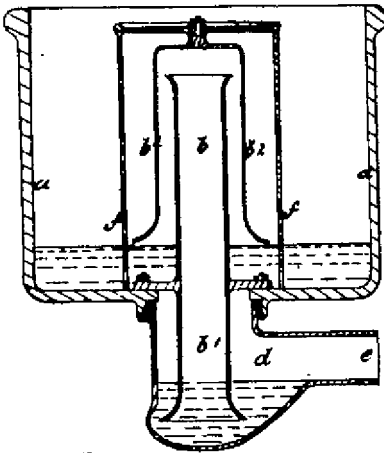


Fig. 3.

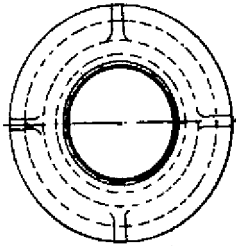


Fig. 4.

Section through A.B.

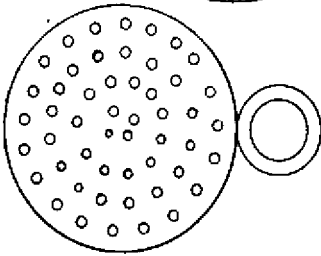


Fig. 7.

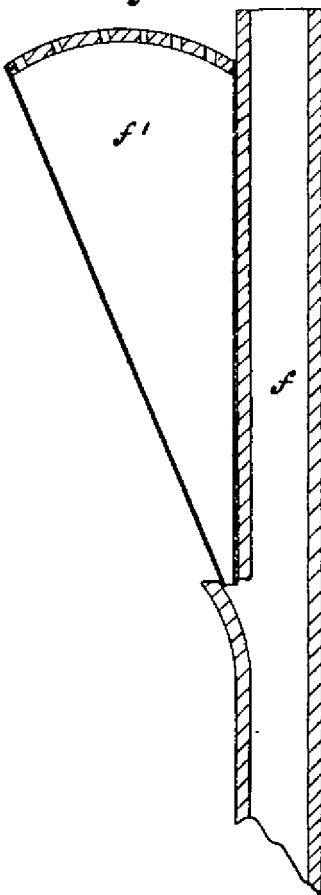
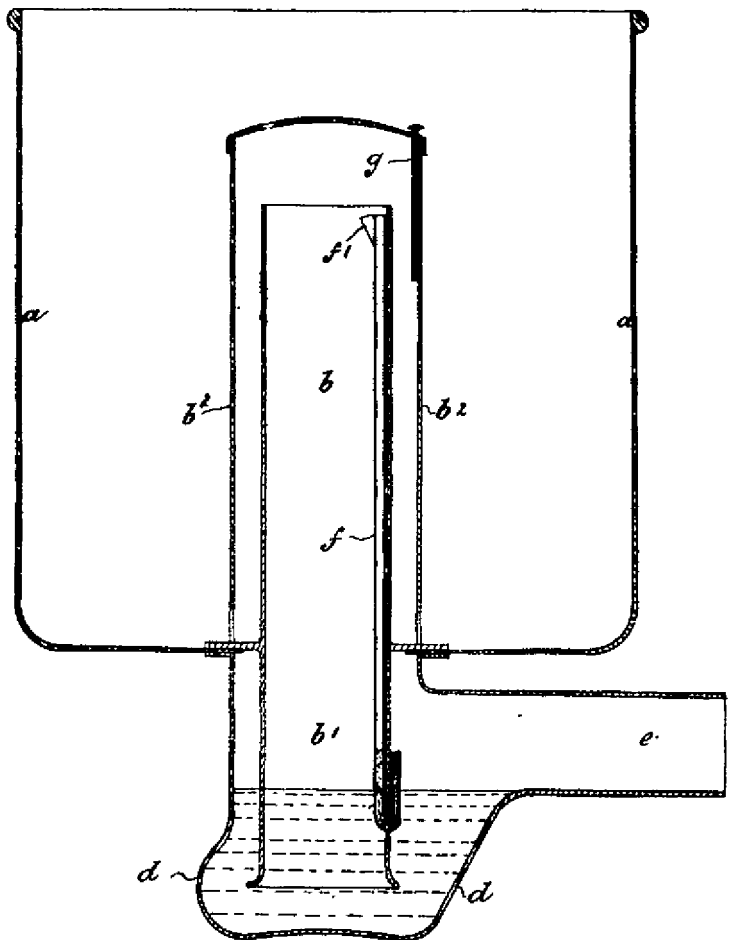


Fig. 6.



(Sig: 245-)

This is the Sheet of Drawings referred to in the annexed Letters of Registration, granted to William Bartholomew, this twenty seventh day of May, A.D., 1884.

Augustus Loftus.



A.D. 1884, 27th May. No. 1432.

IMPROVEMENTS IN FRET-SAW MACHINERY, &c.

LETTERS OF REGISTRATION to George Jackson and Henry Upton Alcock, for Improvements in Fret-saw Machinery, a part of which is applicable to other machinery.

[Registered on the 29th day of May, 1884, in pursuance of the Act 16 Vic. No. 24.]

BY HIS EXCELLENCY THE RIGHT HONORABLE SIR AUGUSTUS WILLIAM FREDERICK SPENCER LOFTUS (commonly called LORD AUGUSTUS LOFTUS), Knight Grand Cross of the Most Honorable Order of the Bath, a Member of Her Majesty's Most Honorable Privy Council, Governor and Commander-in-Chief of the Colony of New South Wales and its Dependencies.

TO ALL TO WHOM THESE PRESENTS SHALL COME, greeting :

WHEREAS GEORGE JACKSON, late of Dunedin, in the Colony of New Zealand, but now of Melbourne, in the Colony of Victoria, wood-worker, and HENRY UPTON ALCOCK, of Melbourne aforesaid, timber merchant, have by their Petition humbly represented to me that the said George Jackson is the author or designer of a certain invention or improvement in manufactures, that is to say, of an invention entitled "Improvements in Fret-saw Machinery, a part of which is applicable to other machinery," which is more particularly described in the specification and the sheet of drawings which are hereunto annexed; and that the said Henry Upton Alcock is the assignee of one half share of and in the said invention so far as the Colony of New South Wales is concerned; and that they, the said Petitioners, have deposited with the Honorable the Treasurer of the said Colony of New South Wales the sum of Twenty Pounds sterling, for defraying the expense of granting these Letters of Registration, as required by the Act of Council, sixteenth Victoria, number twenty-four; and have humbly prayed that I would be pleased to grant Letters of Registration, whereby the exclusive enjoyment and advantage of the said invention or improvement might be secured to them for a period of fourteen years: And I, being willing to give encouragement to all inventions and improvements in the arts or manufactures which may be for the public good, and having received a report favourable to the prayer of the said Petition from competent persons appointed by me to examine and consider the matters stated therein and to report thereon for my information, am pleased, with the advice of the Executive Council, and in exercise of the power and authority given to me by the said Act of Council, to grant, and do by these Letters of Registration grant unto the said George Jackson and Henry Upton Alcock, their executors, administrators, and assigns, the exclusive enjoyment and advantage of the said invention or improvement, for and during the term of fourteen years from the date hereof; to have, hold, and exercise unto the said George Jackson and Henry Upton Alcock, their executors, administrators, and assigns, the exclusive enjoyment and advantage thereof, for and during and unto the full end and term of fourteen years from the date of these presents next and immediately ensuing, and fully to be complete and ended: Provided always, that if the said George Jackson and Henry Upton Alcock shall not, within three days after the granting of these Letters of Registration, register the same in the proper office in the Supreme Court, at Sydney, in the said Colony of New South Wales, then these Letters of Registration, and all advantages whatsoever hereby granted, shall cease and become void.

In witness whereof, I have hereunto set my sign manual, and have caused the present Letters of Registration to be sealed with the seal of the said Colony of New South Wales, at Government House, Sydney, in New South Wales, this 27th day of May, in the year of our Lord one thousand eight hundred and eighty-four.

[L.S.]

AUGUSTUS LOFTUS.

Improvements in Fret-saw Machinery, &c.

SPECIFICATION of GEORGE JACKSON, late of Dunedin, in the Colony of New Zealand, but now of Melbourne, in the Colony of Victoria, wood-worker, and HENRY UPTON ALCOCK, of Russel-street, Melbourne, in the said Colony of Victoria, timber merchant, for an invention entitled "Improvements in Fret-saw Machinery, a part of which is applicable to other machinery."

Our improvements in fret-saw machinery relate—first, to the saw; second, to the arms for supporting the saw; and third, to the bearings for supporting the spindle around which the butt-end of the arms are wound.

Our improvement in fret-saws consists in making them with an enlargement at each end of sufficient size to form a shoulder for holding them in their supporting arms.

Our improvements in the arms for supporting fret-saws consist, first, in the peculiar construction of the upper one, which is made of two lengths of wire, each of which is fastened at its base to the base-board or table of the machine, and is then coiled around its supporting spindle until it reaches the bearing near its outer end, when it is carried forward to the point of travel of the saw.

The two forward ends of these wires are then twisted together, and one is allowed to project a little farther than the other. This projecting part is bent slightly upward, and is slit or slotted for the reception of the top end of the saw. A check-chain passes around each of the forward ends of said wire to prevent them springing upwards too far, in the event of the upper arm, which they constitute, becoming accidentally or intentionally disconnected from the saw. Our improvements in the arms for supporting fret-saws, consist secondly, in the peculiar construction of the lower arm, which is made of two wires twisted together for a short distance at the one end, and then spread out for a distance of about 2½ to 3 in., and then brought together again so as to form an oblong slot or hole for the guide or crank block to slide in. One wire is carried out a little distance beyond the other (as in the top arm) and bent slightly downward, and into this a slot is cut for inserting the saw. The other ends of the wires are separately twisted or coiled into the form of a spiral spring, and their ends fastened or inserted into the base-board table or stand. Into the spirals or coils we pass a wood or metal spindle.

Our improvements in the bearings for supporting the spindle around which the butt-ends of the arms are wound consist of wire twisted into the form of a spiral of two or more coils, the hole formed in the spiral constituting the bearing. The ends of these wires are bent over, and eyes are formed in their ends for the passage of screws with which to fasten them to the table. This is the part of our invention which is applicable to other machinery beside fret-saws.

Referring to our drawings, figure 1 shows top view of a fret-saw and its attachments, constructed according to this invention; figure 2 side elevation; and figure 3 view of same turned bottom upwards. Figure 4 shows our fret-saw with the enlargement at the end, and figure 5 perspective of our novel bearings. The two wires which form the upper arm are marked A and A', the latter having a slit A² at its extremity for the reception of the upper end of the fret-saw B, the enlargement B¹ on which prevents it slipping through said slit. The two wires which form the lower-arm are marked C and C', the latter having a slit C² at its extremity for the reception of the lower end of the fret-saw B, which also has an enlargement B¹ to prevent it slipping through slit C². A³ is the supporting spindle for the upper arm, and A⁴ the coiled wire-bearings which support it. A⁵ is the check-chain hereinbefore referred to. C³ is the supporting spindle for the lower arm and C⁴ the coiled wire-bearings which support it. C⁵ is the oblong space for the passage of the crank-block D to slide in. This crank-block is worked by the crank-spindle D¹, which rests in coiled wire-bearings D², and is driven by a strap or cord passing around pulley D³, and receiving motion by treadle or otherwise, as is well understood. D⁴ D⁴ are simply coiled wire collars to prevent any lateral movement of the crank-spindle.

Fret-saw machinery constructed according to this invention is very cheap, easily worked, and the saws can be connected and disconnected almost instantaneously.

Having thus described the nature of this invention, and the manner of performing same, we would have it understood that what we believe to be new, and therefore claim as our improvements in fret-saw machinery, is—

First—Constructing the upper arm of two wires coiled around a common spindle twisted together at their projecting ends, and with a slit in one of them for the reception of the saw, substantially as herein described and explained.

Second—Constructing the lower arm of two wires coiled around a common spindle and projecting forwards to the line of travel of the saw, where the two wires are twisted together, and where the longest one has a slit in it to receive the saw, and behind which there is a slot between them for the travel of the crank-block, substantially as herein described and explained.

Third—Constructing fret-saws with an enlargement at each end to prevent them from slipping through their bearings, substantially as herein described and explained.

Fourth—Constructing bearings for the spindles of fret-saw and any other machinery of coiled wire, substantially as herein described and explained.

In witness whereof, we, the said George Jackson and Henry Upton Alcock, have hereto set our hands and seals, this twenty-eighth day of March, 1884.

GEORGE JACKSON.
H. U. ALCOCK.

Witness to the signatures of Geo. Jackson and H. U. Alcock,—
ROBERT NAIRN.

This is the specification referred to in the annexed Letters of Registration granted to George Jackson and Henry Upton Alcock, the twenty-seventh day of May, A.D. 1884.

AUGUSTUS LOFTUS.

REPORT:

Sir,

The application of Messrs. Jackson and Alcock for Letters of Registration for an invention entitled "Improvements in Fret-saw Machinery," having been referred to us, we have examined the plan and specification accompanying same, and have now the honor to report that we see no objection to the issue of Letters of Registration, as applied for.

We have, &c.,
ARCH. C. FRASER.
THOS. RICHARDS.

The Under Secretary of Justice.

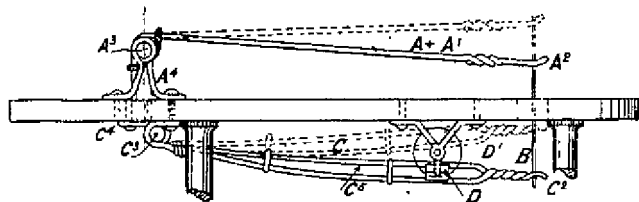


Fig: 2.

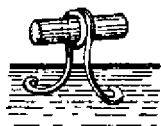


Fig: 5.

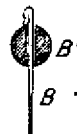


Fig: 4.

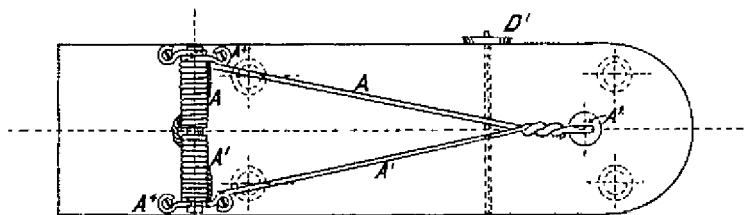


Fig: 1.

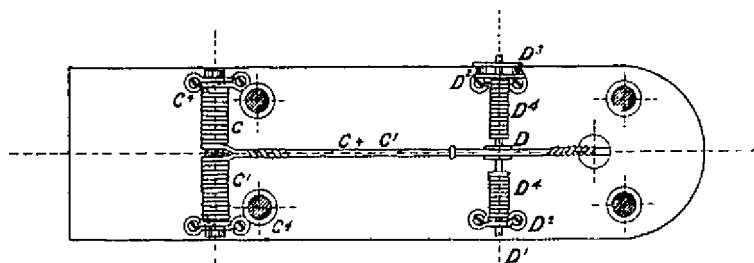


Fig: 3

This is the Sheet of Drawings referred to in the annexed Letters of Registration, granted to George Jackson and Henry Upton Alcock, the twenty-seventh day of May, A. D. 1884.

Augustus Loftus.

(Sig; 245.-)



A.D. 1884, 27th May. No. 1433.

IMPROVED APPARATUS FOR DELIVERING PREPAID GOODS.

LETTERS OF REGISTRATION to John Glas Sandeman and Percival Everitt,
for an Improved Apparatus for Delivering Prepaid Goods.

[Registered on the 29th day of May, 1884, in pursuance of the Act 16 Vic. No. 24.]

BY HIS EXCELLENCY THE RIGHT HONORABLE SIR AUGUSTUS WILLIAM FREDERICK SPENCER LOFTUS
(commonly called LORD AUGUSTUS LOFTUS), Knight Grand Cross of the Most Honorable Order of
the Bath, a Member of Her Majesty's Most Honorable Privy Council, Governor and Commander-in-
Chief of the Colony of New South Wales and its Dependencies.

TO ALL TO WHOM THESE PRESENTS SHALL COME, greeting :

WHEREAS JOHN GLAS SANDEMAN, gentleman, and PERCIVAL EVERITT, engineer, both of London, England, have by their Petition humbly represented to me that they are the authors or designers of a certain invention or improvement in manufactures, that is to say, of an invention entitled "Improved Apparatus for Delivering Prepaid Goods," which is more particularly described in the specification and the sheet of drawings which are hereunto annexed; and that they, the said Petitioners, have deposited with the Honorable the Treasurer of the said Colony of New South Wales the sum of Twenty Pounds sterling, for defraying the expense of granting these Letters of Registration, as required by the Act of Council, sixteenth Victoria, number twenty-four; and have humbly prayed that I would be pleased to grant Letters of Registration, whereby the exclusive enjoyment and advantage of the said invention or improvement might be secured to them for a period of fourteen years: And I, being willing to give encouragement to all inventions and improvements in the arts or manufactures which may be for the public good, and having received a report favourable to the prayer of the said Petition, from competent persons appointed by me to examine and consider the matters stated therein and to report thereon for my information, am pleased, with the advice of the Executive Council, and in exercise of the power and authority given to me by the said Act of Council, to grant, and do by these Letters of Registration grant unto the said John Glas Sandeman and Percival Everitt, their executors, administrators, and assigns, the exclusive enjoyment and advantage of the said invention or improvement, for and during the term of fourteen years from the date hereof; to have, hold, and exercise unto the said John Glas Sandeman and Percival Everitt, their executors, administrators, and assigns, the exclusive enjoyment and advantage thereof, for and during and unto the full end and term of fourteen years from the date of these presents next and immediately ensuing, and fully to be complete and ended: Provided always, that if the said John Glas Sandeman and Percival Everitt shall not, within three days after the granting of these Letters of Registration, register the same in the proper office in the Supreme Court, at Sydney, in the said Colony of New South Wales, then these Letters of Registration, and all advantages whatsoever hereby granted, shall cease and become void.

In witness whereof, I have hereunto set my sign manual, and have caused the present Letters of Registration to be sealed with the seal of the said Colony of New South Wales, at Government House, Sydney, in New South Wales, this twenty-seventh day of May, in the year of our Lord one thousand eight hundred and eighty-four.

[L.S.]

AUGUSTUS LOFTUS.

Improved Apparatus for Delivering Prepaid Goods.

SPECIFICATION of JOHN GLAS SANDEMAN and PERCIVAL EVERITT, both of London, England, for an invention entitled "Improved Apparatus for Delivering Prepaid Goods."

THE main object of this invention is to facilitate the automatic delivery of post-cards and stamped envelopes with a blank enclosure to persons depositing, say, a penny or two pence, in a slit or slits prepared for the reception of such coin.

For this purpose we provide a case or box made either of wood or metal (say, for example, cast iron) with suitable locked receptacles for the articles to be sold, and for the purchase money.

In this case we fit an arrangement of mechanism, which is designed to be set in action by the deposit of the coin given in exchange, say for the post-card, which mechanism will unlock a slide, and permit of its being drawn out with a post card upon it; the coin, meanwhile, will find its way into a locked drawer.

In the accompanying drawing, figure 1 is a front elevation of the apparatus, the upper part of the case being slanted to form a writing-desk; figure 2 is a plan view of the same, the slide being drawn out, showing a post-card upon the same; and figure 3 is a side elevation of the same.

Figure 4 is a sectional plan of the apparatus taken in the line 1-2 of figure 1; figure 5 is a vertical section taken in the line 3-4 of figure 2; and figures 6 and 7 are transverse vertical sections, taken respectively in the lines 5-6 and 7-8 of figure 3.

In these figures A is the case, made by preference of wood for indoor use, and of cast iron for out of door use. The inclined top of this case is composed of two pieces *a*, *a'*. The piece *a* is hinged to the case, and is provided with a ledge for preventing the slipping off of the post-card, which the purchaser may place thereon as on a writing-desk. The piece *a'* is made fast in its place, it being provided with a pendant screw-bolt *a''*, which passes through a socket fixed within the case, and is secured by a binding nut. This arrangement of the part *a'* permits of its removal to allow of the insertion or withdrawal of the mechanism, the construction of which will now be described.

In the case A we fit vertically a skeleton frame B, which is provided at bottom with ledges *bb* to receive and support a pile of post-cards. This frame rests upon the rebated edges of a delivery slide C, which is mounted in suitable guides in the case, and is prevented from being withdrawn from the case by means of a stop provided for the purpose. This slide is partially covered with a plate of metal C, which projects above its face a distance corresponding to the thickness of the article to be delivered. This plate is slotted to correspond with slots in the slide C, hereinafter mentioned.

Recessed into the face of this slide are springs *c'e'*, which bear up against the bottom of the pile of cards contained in the skeleton frame B, but are held down level with the slide by means of a weight B' overlying the pile of cards.

This slide C, when in its normal position, is locked in place; but when unlocked, in the manner to be presently explained, it will be free to be drawn forward by the aid of a handle, with which it is provided, and in moving forward it will draw out, by means of the plate *c* the undermost card, which will then be lifted by the spring *c'* into a position that will facilitate its being picked up by the purchaser (as shown at figure 3).

Underlying this delivery slide is a locked receptacle D for the coin dropped into the case to cover the purchase made. There is also, situate under this slide, a chute E leading to a cup E' set in front of the case for the purpose of receiving coin that is rejected by the apparatus as insufficient to cover the intended purchase.

In the fixed piece *a'* of the case a slit *l* is made for the admission of the coin, and above this a larger slit 2 is made for the purpose to be hereafter explained. The coin on dropping through the slit *l* passes down a vertical channel F, formed by bolting two flat plates of metal F¹ F² together. It is upon the plate F¹, or upon the side of plate F² next to F¹ where the plate F¹ is cut away for lightness sake, that all the moving mechanism of the apparatus is mounted.

The channel F, the course of which is clearly shown by dotted lines in figures 5 and 6, is contracted in width by an arm G, pendant from a pivot pin on the channel-plate F², the lower end of which enters a slot *g*, formed in the delivery slide C, one end of the slot inclining transversely thereto.

Opposed to this pendant arm is the bent end *h* of a weighted rock lever H, pivoted in a bracket upon the plate F². The bent end *h* of this rock lever H is so arranged with respect to the channel F as to receive upon it the penny which is inserted into the case. The weight of the penny will rock this lever, and cause it to tip out of the vertical the pendant end *i* of a suitably placed bell-crank lever I, which serves to lock the delivery slide C by dipping into a slot J formed therein. This tipping of the bell-crank lever I will bring its pendant arm I into line with an opening *j* in the slot J, running in the line of transverse of the delivery slide, and thus unlock the slide, leaving it free to be drawn out, as already explained.

As the drawing out takes place the inclined part of the slot *g*, before mentioned, will draw back the pendant arm G against which the penny bears, thus making room for the penny to slide off the bent end *h* of the rock lever H, which supports it, and drop into the delivery slide C. A further forward movement of this slide will present an opening *d* to the penny, which, falling through the opening, will be received into the drawer D below.

It will now be understood that the apparatus in the act of delivering the prepaid post-card will open a way for the deposit of the money into the locked depository D for the coin.

Supposing now it should be attempted to obtain a post-card by the payment of a smaller coin than a penny, this coin will not be retained by the weighted lever H and pendant arm G, but it will fall directly through an opening *e* in the slide C, and being caught by the chute E, before mentioned, which underlies that slide, will be conducted into the cup E', before mentioned, without acting upon the mechanism in the case.

In order that the attendant may know when the skeleton frame B is exhausted of post-cards, the following contrivance is provided:—Pivoted to a bracket K mounted upon the plate F¹ is a frame *k*, carrying a tablet bearing the word "empty", projecting from the side of the frame *k* is a lug *k'*, which overlies and is acted upon by a vertical rod *l* passing through a guide K' upon the bracket K, and pivoted to the lighter arm at *l'* of a weighted rock lever L. The weighted rock lever L is pivoted to a bracket L' carried by the plate F², and has its arm L² produced and bent so as to underlie and be depressed by the pile of post-cards pressed down in the skeleton frame B by the weight B'. As

Improved Apparatus for Delivering Prepaid Goods.

As long as a card remains in the skeleton frame B the arm L^2 of the weighted rock lever L is held depressed, and the weighted arm raised, but so soon as the last card is withdrawn the arm L^2 of the lock lever is no longer depressed, a hole b^1 in the weight B^1 being provided to allow it to rise; the weighted end of the lever L therefore falls, and the lever L is rocked upon its pivot. The rocking of this lever L raises the vertical rod l , and thereby lifts, by means of the lug k^1 , the frame k . The tablet bearing the word "empty," which is carried by the frame k , is thus raised through the slit 2 in the fixed piece a^1 of the case above mentioned, and exposed to view.

When the skeleton frame B is exhausted of post-cards it is advisable to close the slit l to prevent the insertion of purchase money to no purpose.

This closing is effected by rocking the end of a curved closing piece M mounted in bearings in the bracket K across the slit l . The rocking of the closing piece M is effected by a horizontal projection m on its lower part coming in contact with a projection on the rod l as it is raised by the rocking of the weighted lever L when the last post-card is withdrawn from the frame B. It will thus be seen that the act of withdrawing the last post-card will perform the double office of closing the slit l and exposing the tablet bearing the word "empty" to view.

To prevent the deposit of two coins in succession, or before the slide has been drawn out to deliver a card for the first payment, provision is made for closing the slit l , and retaining it closed until the slide has been drawn out and the post-card paid for delivered to the purchaser. The closing of the slit in this case is effected by the closing piece M, actuated by a vertical rod m^1 , pivoted thereto at or near the projection m . The end of this vertical rod m^1 overlies the weighted end of the rock lever H, so that when the lever H is rocked by the dropping of a coin into its bent end h its weighted end strikes against the end of the rod m^1 and thrusts it in an upward direction, thereby rocking the closing piece M and shutting the slit l . As long as the coin remains upon the end h of the lever H or the slide C remains closed the slit l will remain shut. A provision is also made for keeping the slit l shut until the slide C, after being drawn out, is returned to its normal position. For this purpose a vertical rod m^2 underlies a lug upon the closing piece M in such a way that if the rod m^2 is thrust in an upward direction the closing piece M is rocked across the slit l . The end of this vertical rod m^2 is pivoted to the light end of a weighted lever N, pivoted horizontally at about the middle of its length in a bracket upon the plate F^2 , and having a tail n which catches against the end of a groove n^1 in the slide C when pushed in, thereby tipping up the weighted end of the lever N. When, however, the slide C is drawn out, the tail n of the lever N is released, and the weighted end falls. The light end rising drives the rod m^2 in an upward direction, thereby rocking the closing piece M, and shutting the slit l .

The closing piece M in every case falls back by its own weight, and leaves the slit l open, as soon as the apparatus resumes its normal position.

In adapting the invention for delivering stamped envelopes containing a sheet of writing-paper we prefer to duplicate the locking apparatus, so that it will require the application of two coins of the proper denomination to unlock the delivery slide, instead of one, as above explained.

These two forms of the apparatus or apparatus for delivering stamped envelopes and post-cards may be combined in one box or case, which case we propose to secure to a desk or table in public rooms, at railway stations, and similar places of resort where it may be found convenient to provide facilities for writing.

We also propose to attach such apparatus to pillar-boxes, so that post-cards may be obtained at the spot where provision is made for posting them.

It will be obvious from the foregoing that our invention is applicable to the delivery of other prepaid goods than those already mentioned, such, for example, as packets of cigarettes, the fittings of the delivery slide, and also the skeleton frame, being modified to suit the change of circumstances.

Having now described the nature of the said invention of "Improved Apparatus for Delivering Prepaid Goods," and explained the manner of carrying the same into effect, we claim—

The arrangement of apparatus above described, where by the deposit in the case containing the articles to be purchased of the proper money for effecting such purchase will unlock a delivery slide, and will discharge the money into a receptacle on the drawing out of the slide.

In witness whereof, we, the said John Glas Sandeman and Percival Everitt, have hereto set our hands and seals, this twentieth day of January, one thousand eight hundred and eighty-four.

JOHN GLAS SANDEMAN.
P. EVERITT.

This is the specification referred to in the annexed Letters of Registration granted to John Glas Sandeman and Percival Everitt, the twenty-seventh day May, A.D. 1884.

AUGUSTUS LOFTUS.

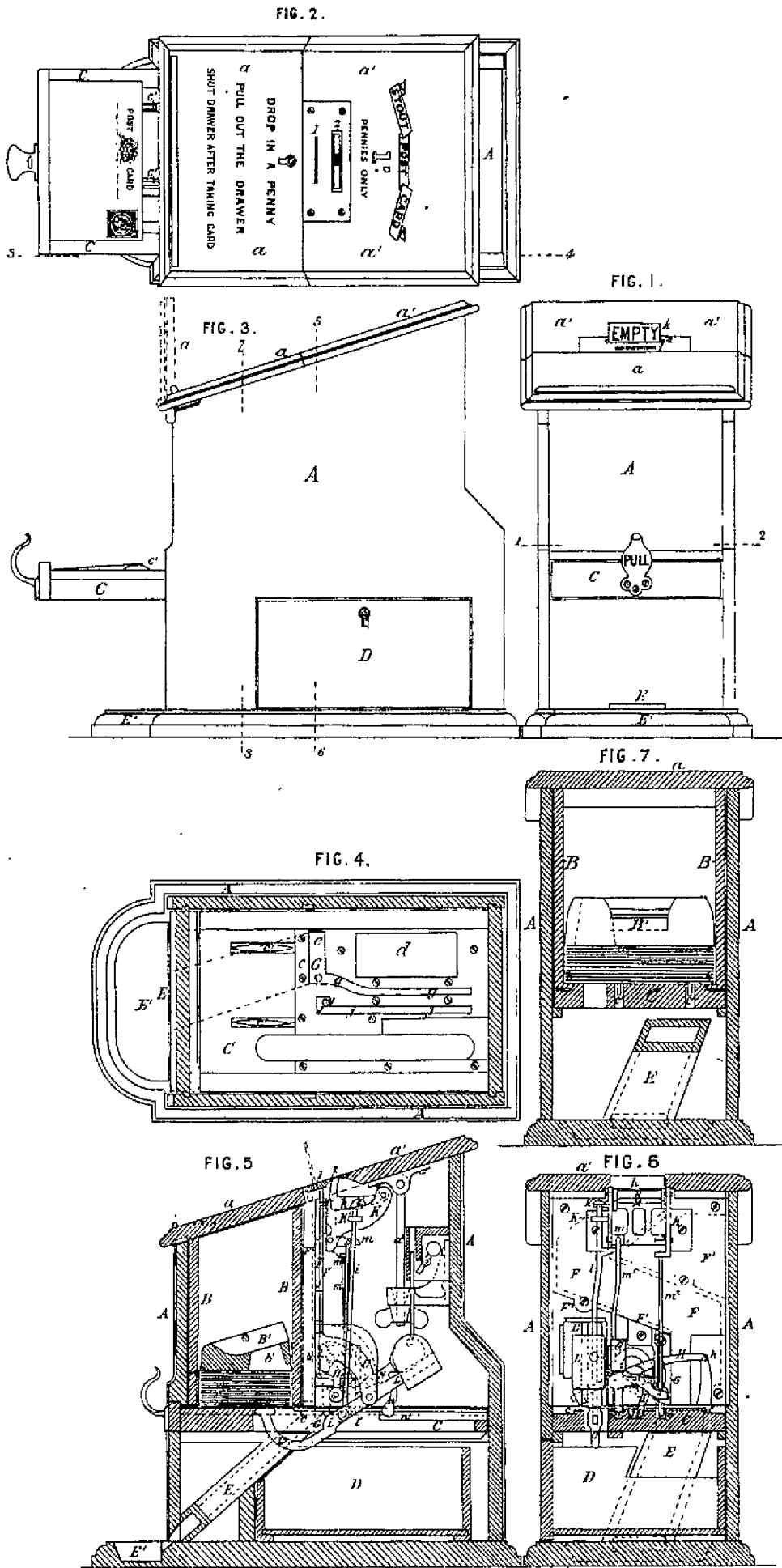
REPORT.

Sir,

The application of Messrs. John Glas Sandeman and Percival Everitt, for Letters of Registration for "Improved Apparatus for Delivering Prepaid Goods" having been referred to us by your blank cover of 4th instant, we do ourselves the honor to report that we have examined the specification and drawings accompanying the same, and that we see no objection to the issue of Letters of Registration, in accordance with the prayer of the Petition.

Sydney, 10 April, 1884.
We have, &c.,
ARCH. C. FRASER.
THOS. RICHARDS.

The Under Secretary of Justice.



This is the Sheet of Drawings referred to in the annexed Letters of Registration, granted to John Glas Sandeman and Percival Everitt, the twenty seventh day of May, A.D., 1884.

Augustus Loftus.



A.D. 1884, 27th May. No. 1434.

IMPROVEMENTS IN ELECTRIC CABLES OR CONDUCTORS.

LETTERS OF REGISTRATION to Louis Adolphe Fortin Herrmann, for Improvements in Electric Cables or Conductors.

[Registered on the 29th day of May, 1884, in pursuance of the Act 16 Vic. No. 24.]

BY HIS EXCELLENCY THE RIGHT HONORABLE SIR AUGUSTUS WILLIAM FREDERICK SPENCER LOFTUS (commonly called LORD AUGUSTUS LOFTUS), Knight Grand Cross of the Most Honorable Order of the Bath, a Member of Her Majesty's Most Honorable Privy Council, Governor and Commander-in-Chief of the Colony of New South Wales and its Dependencies.

TO ALL TO WHOM THESE PRESENTS SHALL COME, greeting :

WHEREAS LOUIS ADOLPHE FORTIN HERRMANN, of Paris, in the Republic of France, hath by his Petition humbly represented to me that he is the author or designer of a certain invention or improvement in manufactures, that is to say, of an invention entitled "Improvements in Electric Cables or Conductors," which is more particularly described in the specification and the sheet of drawings which are hereunto annexed ; and that he, the said Petitioner, hath deposited with the Honorable the Treasurer of the said Colony of New South Wales the sum of Twenty Pounds sterling, for defraying the expense of granting these Letters of Registration, as required by the Act of Council, sixteenth Victoria, number twenty-four ; and hath humbly prayed that I would be pleased to grant Letters of Registration, whereby the exclusive enjoyment and advantage of the said invention or improvement might be secured to him for a period of fourteen years : And I, being willing to give encouragement to all inventions and improvements in the arts or manufactures which may be for the public good, and having received a report favourable to the prayer of the said Petition, from competent persons appointed by me to examine and consider the matters stated therein and to report thereon for my information, am pleased, with the advice of the Executive Council, and in exercise of the power and authority given to me by the said Act of Council, to grant, and do by these Letters of Registration grant unto the said Louis Adolphe Fortin Herrmann, his executors, administrators, and assigns, the exclusive enjoyment and advantage of the said invention or improvement, for and during the term of fourteen years from the date hereof ; to have, hold, and exercise unto the said Louis Adolphe Fortin Herrmann, his executors, administrators, and assigns, the exclusive enjoyment and advantage thereof for and during and unto the full end and term of fourteen years from the date of these presents next and immediately ensuing, and fully to be complete and ended : Provided always, that if the said Louis Adolphe Fortin Herrmann shall not, within three days after the granting of these Letters of Registrations, register the same in the proper office in the Supreme Court, at Sydney, in the said Colony of New South Wales, then these Letters of Registration, and all advantages whatsoever hereby granted, shall cease and become void.

In witness whereof, I have hereunto set my sign manual, and have caused the present Letters of Registration to be sealed with the seal of the said Colony of New South Wales, at Government House, Sydney, in New South Wales, this twenty-seventh day of May, in the year of our Lord one thousand eight hundred and eighty-four.

[L.S.]

AUGUSTUS LOFTUS.

Improvements in Electric Cables or Conductors.

TO ALL TO WHOM IT MAY CONCERN: Be it known that I, LOUIS ADOLPHE FORTIN HERRMANN, of Paris, in the Republic of France, have invented or discovered Improvements in Electric Cables or Conductors; and I, the said Louis Adolphe Fortin Herrmann, do hereby declare the nature of the said invention, and in what manner the same is to be performed, to be particularly described and ascertained in and by the following statement thereof, that is to say:—

My invention relates to such a construction of the insulating covering of electric conducting wires or cables that the wire or wires shall be bathed in a free circulation of air or gas, or even a liquid within an external envelope or tube.

To this end the wire or cable is insulated and held in place within a tubular envelope or covering, which may be of conducting or non-conducting material, by stringing or threading upon the wire or cable short tubular pieces of insulating material having more or less the external form of beads, which leave spaces to allow of a free circulation of air or gas around the wire or cable.

In order that the invention may be more readily understood, I have illustrated some examples of the same in the accompanying drawings. Figure 1 is a longitudinal section of a cable composed of seven wires, and figure 2 a cross-section of same on line 1-2; figure 3 is a longitudinal section of a cable of seven wires, and figure 4 a cross-section of same on line 3-4; figure 5 shows the mode of splicing two lengths of cable, and figure 6 a cross-section of the splice taken on line 5-6; figure 7 shows a modified form of splice, figure 8 a cross-section taken on line 7-8, and figure 9 a plan of same. The same letters of reference denote the same parts in all the figures.

a is the conducting wire or cable upon which are strung short lengths or bead-like pieces *b* of insulating material, such as wood, glass, enamelled-ware, or porcelain, which may be either round, as in figures 1, 2, 5, 6, or elongated as in figures 3, 4, 7, 8, and of any size desired. The wire or cable after being threaded through these bead-like pieces is introduced into a tubular envelope *c*, which may or may not be of insulating material, leaving vacant spaces *d* in which air or gas, or it may be a liquid, may freely circulate. Any number of wires or cables *a*, strung with insulating beads or tubular pieces *b*, may be laid side by side and enclosed within the same envelope or tube *c* of sufficient diameter.

The wires or cables may before being strung with bead-like distance and insulating pieces *b* receive one or more servings, and the envelope or tube may be sheathed if desired.

The splicing of the wires is effected by introducing the ends, which are bevelled off, so as to form a scarf-joint, into a small tube *e e* of thin metal; figures 5 to 9, open on the upper side at *f f* for soldering the whole together with tin or silver solder; in figures 7, 8, and 9, the tube *e e* is shown as enclosed in a distance piece *b'*, which may be of the sectional form shown at figure 8 for example, against which the ends of the two tubes or envelopes *c* abut, but in figures 5 and 6 this piece *b'* is absent, the ends of tubes *c* abutting together. In both cases the joint of the envelope *c* is enclosed in a sleeve *g* soldered at *h h*.

The form, dimensions, and details of the various parts may be varied without departing from the invention.

Having thus described the nature of my invention, and the manner of performing the same, I declare that what I claim as my invention is—

- 1st. An electric conductor or cable, consisting in the combination with the conducting wire or wires of bead-like lengths, pieces or cylinders of insulating material strung thereon, and of an outer tubular covering (conducting or otherwise) enclosing said bead-like pieces so as to permit the free circulation of a gas or liquid, substantially as shown and described.
- 2nd. The modes of splicing the cables hereinbefore specified, substantially as shown in the drawings.
- 3rd. The grouping of a number of wires or cables in the same envelope, each having bead-like lengths of insulating material strung upon it, substantially as described.

The above specification of my invention, signed by me this 23rd day of January, A.D. 1884.

L. A. FORTIN HERRMANN.

This is the specification referred to in the annexed Letters of Registration granted to Louis Adolphe Fortin Herrmann, the 27th day of May, A.D., 1884.

AUGUSTUS LOFTUS.

REPORT.

Sir,

We have examined the drawings and specification of Mr. Louis A. Fortin Herrmann, 84-3290, applying for Letters of Registration for "Improvements in Electric Cables or Conductors," and see no objection to the petition being granted.

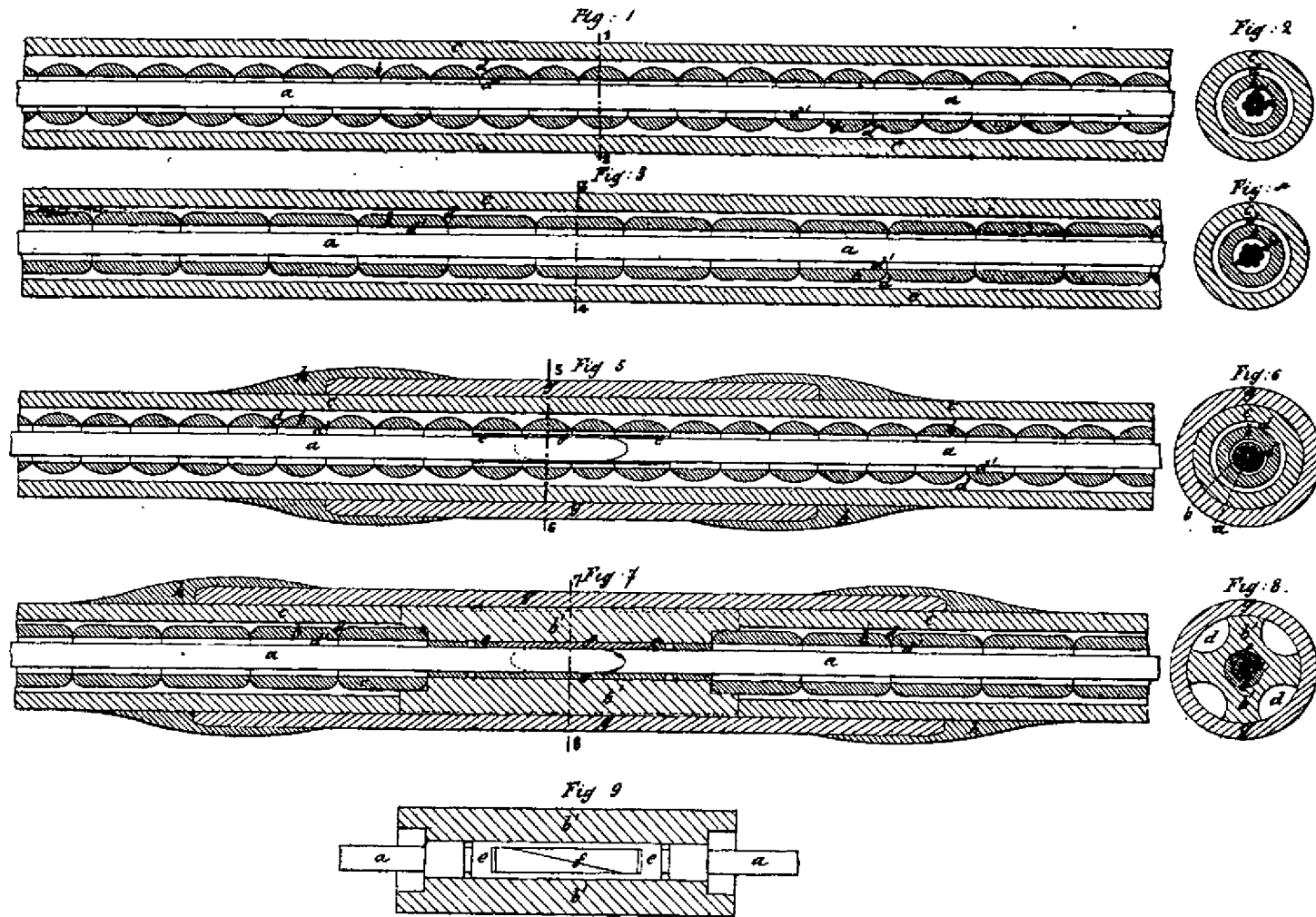
Sydney, 20 March, 1884.
We have, &c.,
E. C. CRACKNELL.
H. C. RUSSELL.

The Under Secretary of Justice.

[Drawings—one sheet.]

No. 1435.

[Assignment of No. 1413.]



(Sig: 245~)

*This is the Sheet of Drawings referred to in the annexed Letters
of Registration, granted to Louis Adolphe Fortin Herrmann,
this twenty seventh day of May, A.D., 1884.*

Augustus Loftus.



A.D. 1884, 16th June. No. 1436.

IMPROVEMENTS IN STEAM-SHIP PROPELLERS.

LETTERS OF REGISTRATION to Robert Wilcox, for Improvements in Steam-ship Propellers and in Machinery for driving same.

[Registered on the 18th day of June, 1884, in pursuance of the Act 16 Vic. No. 24.]

BY HIS EXCELLENCY THE RIGHT HONORABLE SIR AUGUSTUS WILLIAM FREDERICK SPENCER LOFTUS (commonly called LORD AUGUSTUS LOFTUS), Knight Grand Cross of the Most Honorable Order of the Bath, a Member of Her Majesty's Most Honorable Privy Council, Governor and Commander-in-Chief of the Colony of New South Wales and its Dependencies.

TO ALL TO WHOM THESE PRESENTS SHALL COME, greeting :

WHEREAS ROBERT WILCOX, of Fawkner-street, St. Kilda, in the Colony of Victoria, engineer, hath by his Petition humbly represented to me that he is the author or designer of a certain invention or improvement in manufactures, that is to say, of an invention entitled "Improvements in Steam-ship Propellers and in Machinery for driving same," which is more particularly described in the specification, marked A, and the two sheets of drawings, marked B and C, respectively, which are hereunto annexed; and that he, the said Petitioner, hath deposited with the Honorable the Treasurer of the said Colony of New South Wales, the sum of Twenty Pounds sterling, for defraying the expense of granting these Letters of Registration, as required by the Act of Council, sixteenth Victoria, number twenty-four; and hath humbly prayed that I would be pleased to grant Letters of Registration whereby the exclusive enjoyment and advantage of the said invention or improvement might be secured to him for a period of fourteen years: And I, being willing to give encouragement to all inventions and improvements in the arts or manufactures which may be for the public good, and having received a report favourable to the prayer of the said Petition, from competent persons appointed by me to examine and consider the matters stated therein and to report thereon for my information, am pleased, with the advice of the Executive Council, and in exercise of the power and authority given to me by the said Act of Council, to grant, and do by these Letters of Registration grant unto the said Robert Wilcox, his executors, administrators, and assigns, the exclusive enjoyment and advantage of the said invention or improvement, for and during the term of fourteen years from the date hereof; to have, hold, and exercise unto the said Robert Wilcox, his executors, administrators, and assigns, the exclusive enjoyment and advantage thereof, for and during and unto the full end and term of fourteen years from the date of these presents next and immediately ensuing, and fully to be complete and ended: Provided always, that if the said Robert Wilcox shall not, within three days after the granting of these Letters of Registration, register the same in the proper office in the Supreme Court, at Sydney, in the said Colony of New South Wales, then these Letters of Registration, and all advantages whatsoever hereby granted, shall cease and become void.

In witness whereof, I have hereunto set my sign manual, and have caused the present letters of Registration to be sealed with the seal of the said Colony of New South Wales, at Government House, Sydney, in New South Wales, this sixteenth day of June, in the year of our Lord one thousand eight hundred and eighty-four.

[L.s.]

AUGUSTUS LOFTUS.

Improvements in Steam-ship Propellers.

A.

SPECIFICATION of Robert Wilcox, of Fawkner-street, St. Kilda, in the Colony of Victoria, engineer, for an invention entitled "Improvements in steam-ship propellers and in machinery for driving same."

My improved propeller for steam-ships has been designed for the purpose of superseding the screw propellers at present in use, which are placed at the stern of the ship, and is intended to be called the "oscillating propeller."

My propeller is placed under the bottom of the ship, so that it is always under water, and consequently cannot "race," which is one of the greatest objections to ordinary screw propellers.

My improved propeller consists of two oar-shaped blades whose shafts are properly fitted and work in the bearings provided in the lower end of a vertical cylindrical trunk, which also works in suitable water-tight bearings, and projects through the bottom of the ship in a gap provided in the keel of the vessel for that purpose. To this trunk, and consequently to the blades, a reciprocating motion is given by an arm on it which is worked by a connecting rod from the crank-shaft of an engine whose stroke is so regulated as to give to said blades a travel of one hundred and nine degrees or thereabouts. The reciprocating motion may be imparted to the trunk through any arrangement of machinery and by any description of engine. A feathering motion, or motion whereby the blades are alternately turned on their edge at one end and on their side at the other end of the stroke, is given to said blades, so that when they are working in the same direction as the ship the edge of same offers as little resistance as possible to the water, as hereinafter more fully explained. Reversing gear is also provided, by means of which the blade-feathering mechanism may be so set as to immediately alter the blades from propelling the vessel ahead to propelling her astern, or one of the blades may be caused to work ahead and the other astern, so as to turn said vessel. These movements can be accomplished while said trunk and attached mechanism and blades are in full work, and without stopping or reversing the engine.

Referring to my drawings (on sheet 1), figure 1 shows a longitudinal view of a vessel having a pair of my propellers fitted thereto at their proposed positions, and figure 2 cross-section on the line *aa* looking forward. Figure 3, cross-section on the line *bb*, also looking forward, showing the blades in their normal working positions. Figure 4 (sheet 2) is an athwart ship, and figure 5 a fore and aft elevation of my improved propeller and of the machinery for driving it. Figure 6 is an athwart ship sectional elevation of same. Figure 7 is a plan of lower part of same, showing connection from crank-shaft of steam engine to trunk; and figure 8 is a plan on top of suspension plate. Figure 9 is a vertical fore and aft section of the trunk. Figures 10 and 11 are top and bottom plans of same. Figure 12 is a horizontal section at *cc* in figure 9, and figure 13 plan of bottom of said trunk with lower cap removed. Figures 12^a and 10^a are similar views to figures 12 and 10 of an alternative method of arranging the feathering cranks. Figures 9^a and 13^a show vertical section and plan of an alternative construction of the bearings for the propeller shafts. Figure 14 is a back view of the roller carriage. Figure 15 is a plan of top, and figure 16 a plan of bottom roller paths. Figure 17, horizontal section at *dd*, figure 4. Figures 18 and 19 are plans of the upper and lower striking gear for operating the paths, and figures 18^a and 19^a show an alternative construction of the striking arms by facing them with vulcanite or some such material, marked R. Figure 20 shows an alternative form of blade for the propellers. Figures 21 and 21^a show alternative constructions of the feathering rods, and figure 22 shows half elevation and half section, and figure 23 half top plan and half horizontal section of an alternative arrangement for transmitting the feathering motion to the before-mentioned propeller blades.

I will refer now to all the figures excepting those showing alternative methods. Similar letters will indicate the same parts throughout the drawings.

A and A¹ are the two blades, each on its own stem or shaft A² and forming together one propeller. On these shafts are formed the solid collar A³, discs A⁴, and crank pins A⁵, as shown. B is the trunk, and B¹ the vertical shafts to which it is attached by flanges B² bolted together by the tap bolts B³. The lower end of the trunk B is enlarged in diameter, and has a cap B⁴ fitted thereon. This cap is let into a suitable recess in the trunk, and bolted thereto by means of the tap bolts B³. This cap and the lower end of the trunk form the bearings for the shafts A² and discs A⁴, and a packing gland B⁵ is also fitted into them, as shown. In said trunk B a hole is provided at *b* so as to form an outlet for any sea water which may get there. C is the bed plate to which the standards C¹ are bolted, said standards supporting the circular frame D of the roller paths. Into the top flange of said frame D is fixed the four columns E which support and are bolted to the suspension plate E¹, which has a central boss E² on its upper face to form a bearing for the vertical shaft B¹, and also to form a path on which the suspension rollers E³ travel. These rollers revolve on the transverse shaft E⁴ which is fitted into the uppermost end of said vertical shaft B¹. E⁵ is a loose collar fitted on the shaft B¹ and working against the under side of suspension plate E¹, as shown. A large boss C² is formed on and projects downwards from the bed plate C. Into this boss is fitted a bush C³ which is lined inside with strips of lignum vitæ C⁴, as shown in figure 17. Above this is a stuffing box C⁵ fitted with gland C⁶. These parts C², C³, and C⁵ are made in halves, C⁵ being bolted to the bed plate by the bolts C⁷, while the gland into stuffing box is fastened by the bolts C⁸. B⁷ are the connecting rods, B⁸ the cranks working in the bearings B⁹, which are fitted into the upper square portion of trunk B. F are the roller carriage brackets carrying the path rollers F¹, friction rollers F², and guide rods F³, which work in the guide brackets F⁴ fitted on the outside of trunk B. This carriage has an oblong hole or slot F⁵ formed in its back face in which the outer pins on cranks B⁸ work. D¹ are the upper and D² the lower movable roller paths, the upper ones having a dovetailed slide piece D³ formed on them which slides in a suitable recess formed in the path or flange of frame D, and the lower ones having the two dovetailed slide pieces D⁴ which work in suitable recesses in lower roller face of the frame D. It will be noticed that the working surface of the lower roller paths D² are bevelled to suit the lower rollers F¹ as shown. These movable paths D¹ and D² have snugs D⁵ formed on their outer periphery, between which the pins D⁶ are fitted. GG are brackets fixed to the frame D by means of the bolts G¹, and have a pin G² fitted into them which supports the lever G³. G⁴ is a rod connecting said lever G³ with bell crank G⁵. This bell crank has a slotted hole G⁶ for regulating the stroke, and is supported in the bracket G⁷, which is bolted to the top of the

Improvements in Steam-ship Propellers.

the circular frame D. G^8 is a rod connecting the arm G^9 on the square portion of the tappet shaft H to said bell-crank G^5 . G^{10} is a forked bracket bolted to the suspension plate for supporting the arm G^9 . H^1 is a cranked lever supported in the bracket H^2 bolted to the top of suspension plate E¹. This lever has a bow or forked end which carries two pins H^3 fitted therein, said pins being placed in the groove formed in the circular disc H^4 which is keyed to the top end of the tappet shaft H. This tappet shaft is supported at top in a bearing in the suspension plate, and at bottom in a bearing in the arm H^6 projecting from before-mentioned bracket G^7 . H^6 , H^7 , and H^8 are the tappet-arms projecting from said tappet-shaft H. I is the upper collar of the form shown in figure 18, having the three striking pins I^1 bolted into the three oblong holes provided therein. It is keyed on to the vertical shaft B¹ as shown. J is the lower collar of the form shown in figure 19, and having the three striking pins J^1 bolted in the oblong holes therein, which said holes are for the purpose of adjustment, and which said collar is also keyed on to the vertical shaft B¹. The pins I^1 and J^1 in the brackets I and J may have set screws, as shown at J^2 , fitted into the lugs so as to prevent said pins from moving sideways.

K is the cylinder of the engine, K^1 its piston rod, K^2 cross-head, K^3 connecting rod, K^4 crank shaft supported in bearings K^5 at top, and footstep K^6 at bottom, which has a wearing piece of lignum vitæ K^7 fitted therein. K^8 is the fly-wheel. This engine gives the necessary motion to the connecting rod L, which is connected at the one end to the crank shaft K^4 and at the other end to the pin L^1 between the arms L^2 formed on the vertical trunk B, thereby giving the required reciprocating motion through said trunk to the propeller.

The alternative arrangement of one of the double-ended cranks B^8 so as to cause the after edges of the blades to always lift up in the feathering motion when going aft, and which, I think, is preferable, is accomplished by simply making one of the cranks with the pins on different sides of its centre, which crank is marked B^{10} in figure 12^a of the drawings. Figure 10^a shows top view of trunk B with the guide brackets F altered to suit this construction.

Figures 9 and 13^a show the alternative construction of the bearings for the propeller shaft in which the half brasses M are set into the bottom of the trunk and cap, and held therein by the set screws M^1 ; metallic and india-rubber packing rings M^2 and M^3 are inserted in the stuffing-box, as shown.

Figure 21 shows the alternative construction of the feathering rods so as to be able to adjust the top and bottom brasses N by the nuts N^1 on the ends of the strap N^2 , which strap passes around the rod N^3 and the lower brasses, or the end of the strap may be formed into a bow having a central set bolt N^4 , as shown in figure 21^a of the drawings.

Figures 22 and 23 show an alternative arrangement for conveying the motion from the roller paths to the feathering rods in the trunk B. By this arrangement the cranks B^8 in figure 12 and the carriage F in figure 14 are dispensed with, and the path rollers F^1 work on bearings projecting from the guide block O, which has friction rollers O^1 fitted to it working against the inner side of the guide-box O^2 on the one side, and against the flat face of the trunk B on the other side. Projecting inwards from said guide block O, and through the slot in the said trunk, is a pin O^3 to which the connecting rod B^7 is attached. From thence to the blades the mechanical arrangements are the same as already described and shown, more especially in figures 6 and 9.

In each steam-ship there may be two or more of my propellers, and two or more sets of the requisite driving machinery. In figures 1, 2, and 3 I have shown two of such sets, which is what I prefer.

The operation of my propellers, and the machinery for driving and governing same in a ship fitted as I prefer with a pair of such propellers and their driving gear, as illustrated in figures 1, 2, and 3, is as follows:—Motion being imparted to the trunks, and from them to the propellers, by the contrivances shown and already described, causes the starboard blade on the forward and the port blade on the after propeller to be vertical when travelling aft, and consequently the ship to be thereby propelled forward, and the port blade on the forward propeller and the starboard blade on the after propeller to be in the reverse position, that is, edgewise against the water while travelling forward, or, in other words, one of the blades of each propeller should be vertical for that portion of the astern stroke during which it is designed to be so, and edgewise for its full forward stroke, as shown at A¹ and A in figure 4. At each end of the stroke, and in this case, as the lower tappets H^8 are in position, and supposing the machine to have just returned from the forward end on the port side, then the lower striking frame J, which is keyed on to the upright shaft extension B¹, of the trunk B would have come into contact with the arm-tappet H^8 on the tappet shaft H, and through the medium of the arms G^9 , connecting rod G^8 , bell-crank G^5 , connecting rod G^4 , and lever G^3 , which operates the top and bottom movable paths D¹ and D² will place them in the position shown in figure 4, the dotted circles in figure 19 indicating the position the pins J^1 assumed at such time, so as to so place the movable paths. When the end of this stroke is reached, and while the path rollers F^1 are clear of the movable paths D¹ and D², the striking pins J^1 will come in contact with the opposite side of the tappet arms H^8 , thereby shifting the movable paths to the reverse positions, the top one D¹ on the port side will be out, and the lower one D² in, and on the starboard side the top one D¹ will be in, and the lower one D² out, so that the carriages F and rollers F^1 travelling between the paths, as described, will cause the blade A to be vertical in coming astern, and the blade A¹ edgewise in going ahead. The feathering gear from path rollers F^1 to blades A and A¹ is as follows:—The rollers F^1 being attached to the carriages F, and such carriages having slots F^3 at their back faces into which the outer pins of the double cranks B^8 work, and the connecting rods B^7 inside the trunk B being connected at their top end to the inner pins of the cranks B^8 and at their lower ends to the pins A^5 on the discs A⁴, the carriages F are caused to rise and fall by travelling on the paths, and so cause the blades A and A¹ to twist or feather from the vertical to the horizontal position.

When it is required to reverse the course of the ship from ahead to astern, which in practice means that the carriage F should travel on top of the movable roller paths D² when working forward, and consequently the blades be vertical when going forward, I require to place the cranked hand-levers H^1 in the position shown in figure 6, and so raise the lower arm-tappets H^8 clear of the lower striking frame J; and the same movement brings the upper arm-tappets H^6 and H^7 into the line of contact with the upper striking-frame I, which, when said frame and tappets come in contact, reverses the movable paths, as required.

Having

Improvements in Steam-ship Propellers.

Having thus described the nature of my invention and the manner of performing same, I would have it understood that I do not confine myself to the particular shapes or forms of the propeller blades shown in the drawings, as any convenient form of blade having the required surface to propel the ship may be used; and further, I do not confine myself to any particular form of steam-engine for driving my propeller, as any description will do if of sufficient power, and placed in any convenient position adjacent to the trunk of said propellers. But what I believe to be new, and therefore claim as my improvements in steam-ship propellers, and in the machinery for driving same, is:—

First—Constructing steam-ship propellers with two oar-shaped blades, so arranged and connected as that each blade has a horizontal reciprocating and a feathering motion, substantially as herein described, and as illustrated in the accompanying drawing.

Second—The combination with my said propellers of a hollow trunk to receive the rods which give the feathering motion to the propeller, substantially as herein described and explained.

Third—The combination of parts forming my improved machinery for communicating and translating the motion of the piston rod of the engine into the necessary motions for working my said propellers, substantially as herein described and explained.

In witness whereof, I, the said Robert Wilcox, have hereto set my hand and seal, this third day of April, one thousand eight hundred and eighty-four.

Witness—

EDWARD WATERS,
Patent Agent, Melbourne.

ROBERT WILCOX.

This is the specification marked A, referred to in the annexed Letters of Registration granted to Robert Wilcox, this sixteenth day of June, A.D. 1884.

AUGUSTUS LOFTUS.

REPORT.

Sir,

Sydney, 26 April, 1884.

In reply to your B.C. of the 7th instant, we have the honor to report that we have examined Mr. Robert Wilcox's application for Letters of Registration for an invention entitled "Improvements in steam-ship propellers and in machinery for driving same," also the specification and drawings therewith, and we see no reason why his application should not be granted.

We have, &c.,
FRANCIS HIXSON.
H. BRODERICK.

The Under Secretary of Justice.

[Drawings—two sheets.]

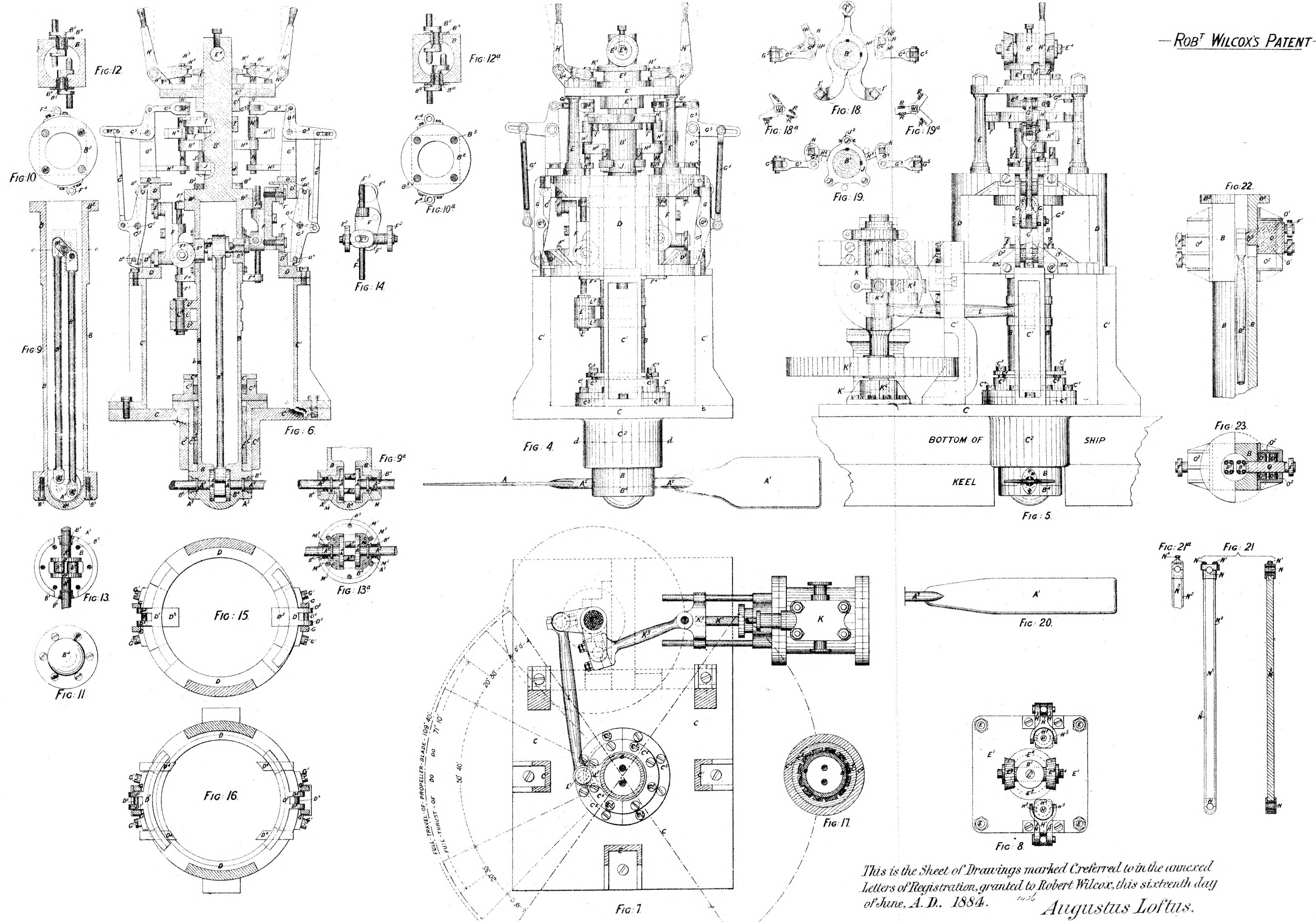
No. 1437.

[Assignment of No. 1255. See Letters of Registration for 1883, page 223.]

No. 1438.

[Assignment of No. 1238. See Letters of Registration for 1883, page 171.]

—ROBT WILCOX'S PATENT—



This is the Sheet of Drawings marked C referred to in the annexed Letters of Registration, granted to Robert Wilcox, this sixteenth day of June, A. D. 1884.

Augustus Loftus.

ROBT WILCOX'S PATENT

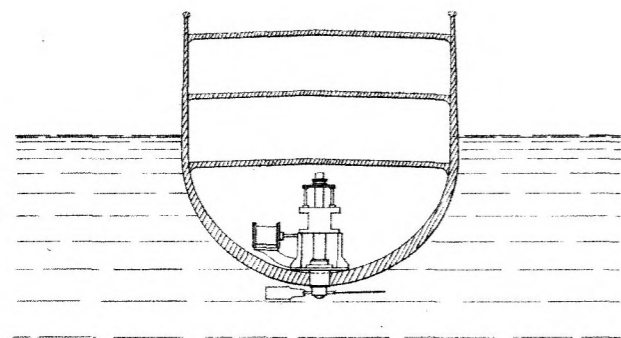


Fig. 2

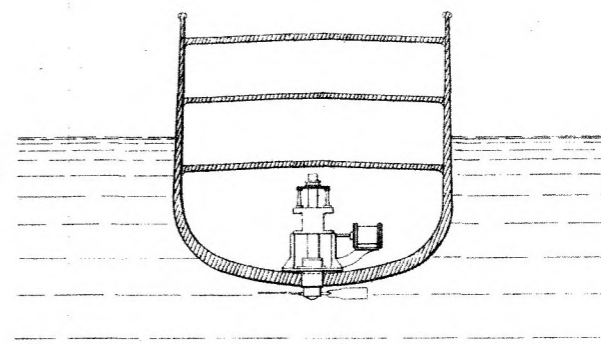


Fig. 3.

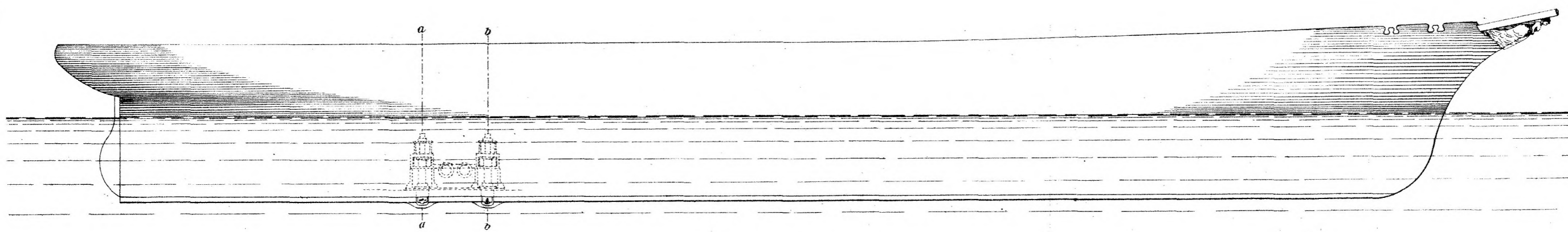
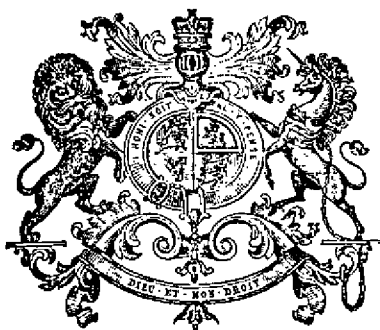


Fig. 1.

*This is the Sheet of Drawings marked B, referred to in the annexed
 Letters of Registration, granted to Robert Wilcox, this sixteenth day
 of June, A. D., 1884.*

Augustus Loftus



A.D. 1884, 23rd June. No. 1439.

IMPROVEMENTS IN THE TREATMENT OF FINELY-DIVIDED AURIFEROUS MATERIAL, &c.

LETTERS OF REGISTRATION to Edward Spencer, for Improvements in the treatment of finely-divided auriferous material for the extraction of Gold and Quicksilver, the residual product being a useful pigment.

[Registered on the 24th day of June, 1884, in pursuance of the Act 16 Vic. No. 24.]

BY HIS EXCELLENCY THE RIGHT HONORABLE SIR AUGUSTUS WILLIAM FREDERICK SPENCER LOFTUS (commonly called LORD AUGUSTUS LOFTUS), Knight Grand Cross of the Most Honorable Order of the Bath, a Member of Her Majesty's Most Honorable Privy Council, Governor and Commander-in-Chief of the Colony of New South Wales and its Dependencies.

TO ALL TO WHOM THESE PRESENTS SHALL COME, greeting :

WHEREAS EDWARD SPENCER, of No. 146, Canning-street, North Carlton, in the Colony of Victoria, builder, hath by his Petition humbly represented to me that he is the author or designer of a certain invention or improvement in manufactures, that is to say, of an invention entitled "Improvements in the treatment of finely-divided auriferous material for the extraction of gold and quicksilver, the residual product being a useful pigment," which is more particularly described in the specification and the sheet of drawings which are hereunto annexed ; and that he, the said Petitioner, hath deposited with the Honorable the Treasurer of the said Colony of New South Wales the sum of Twenty Pounds sterling, for defraying the expense of granting these Letters of Registration, as required by the Act of Council, sixteenth Victoria, number twenty-four ; and hath humbly prayed that I would be pleased to grant Letters of Registration, whereby the exclusive enjoyment and advantage of the said invention or improvement might be secured to him for a period of fourteen years : And I, being willing to give encouragement to all inventions and improvements in the arts or manufactures which may be for the public good, and having received a report favourable to the prayer of the said Petition, from competent persons appointed by me to examine and consider the matters stated therein and to report thereon for my information, am pleased, with the advice of the Executive Council, and in exercise of the power and authority given to me by the said Act of Council, to grant, and do by these Letters of Registration grant unto the said Edward Spencer, his executors, administrators, and assigns, the exclusive enjoyment and advantage of the said invention or improvement, for and during the term of fourteen years from the date hereof ; to have, hold, and exercise unto the said Edward Spencer, his executors, administrators, and assigns, the exclusive enjoyment and advantage thereof, for and during and unto the full end and term of fourteen years from the date of these presents next and immediately ensuing, and fully to be complete and ended : Provided always, that if the said Edward Spencer shall not, within three days after the granting of these Letters of Registration, register the same in the proper office in the Supreme Court, at Sydney, in the said Colony of New South Wales, then these Letters of Registration, and all advantages whatsoever hereby granted, shall cease and become void.

In witness whereof, I have hereunto set my sign manual, and have caused the present Letters of Registration to be sealed with the seal of the said Colony of New South Wales, at Government House, Sydney, in New South Wales, this twenty-third day of June, in the year of our Lord one thousand eight hundred and eighty-four.

[L.S.]

AUGUSTUS LOFTUS.

Improvements in the treatment of finely-divided auriferous material, &c.

SPECIFICATION of EDWARD SPENCER, of No. 146, Canning-street, North Carlton, in the Colony of Victoria, builder, for an invention entitled "Improvements in the treatment of finely-divided auriferous material for the extraction of gold and quicksilver, the residual product being a useful pigment."

This invention has been designed mainly for the purpose of treating those classes of auriferous material which contain sulphur and arsenic, and its principal object is to extract the gold therefrom, the residual product being a useful pigment. It is equally useful, however, in the treatment of those classes of auriferous material which are destitute of these baser metals, and incidentally it will save any quicksilver that may have become mixed with the material treated.

In order to vitiate the deleterious effect of the arsenic and sulphur I repeatedly wash the material containing it in a chemical solution, which sets the gold free, and allows it to amalgamate with the quicksilver whenever it has an opportunity; and in order to effect this washing and amalgamation, I subject it to the action of certain mechanical contrivances which are hereinafter explained, and are illustrated by the drawings hereto attached. This chemical solution and these mechanical contrivances and the use of the residual product as a pigment form the subject matter of my invention.

My chemical solution consists of a solution of Roche lime and washing-soda, thus:—I take, say, two hundredweight of fresh Roche lime, and mix it and six pounds of common washing-soda with, say, one hundred and twenty gallons of fresh water, stirring it all well together. I then remove this mixture to another vessel and allow it to settle. When settled I draw off the supernatant liquor, which is the solution I use.

My mechanical contrivances are illustrated in the sheet of drawings hereto attached, in which figure 1 shows a plan of the whole drawn to a smaller scale than any of the other figures, while figure 2 shows vertical section on the line *aa*, in figure 1. Figure 3 cross-section on the line *bb* in figure 2, with the framing and gearing shown in elevation, and figure 4 is a side elevation of No. 6 box and framing, the box having portion of its side broken away so as to show the cistern *E*, which, with the rake-box, is a vertical section on the line *cc* in figure 1. Figure 5 shows end section on the line *dd* in figure 2, with the overhead framing and shoot in elevation. Figure 6, longitudinal section on the line *ee* in figure 4. Figure 7 shows on a larger scale a section of the pipes *F* and *F'*, the boss *L*, the india-rubber washer *L'*, part of the tank *E*, and the amalgam discharge pipe *M*. Figure 8 shows on an enlarged scale the pipe *F* and part of the tank *E* in figure 3, whilst figure 9 shows details of the agitating cage.

Referring to figures 2, 3, and 5, *A* is a feed-box for the material to be treated; *B* is an elevator, enclosed for the most part of its length in a sheet-iron casing *B'*; *C* is a box, which may be made of either wood or iron; if made of wood, it must be lined with either copper or iron plating. It is quite closed except at the holes made for the feed shoot *B'*, and for the sheet-iron casing *D* of the elevator *D'*, which discharges itself into the shoot *P* leading to the cistern in the next box. *E* is a strong iron cistern supported on side bars *E'*, and having in its bottom a tapped opening, through which is screwed a pipe *F*. In this cistern is a series of converging wire rods *G*, connected together at top by a flat iron ring *G'*, and near the bottom by a smaller flat iron ring *G''*. On the inner side of each of these wire rods are two projecting studs or fingers *G'''*. This series of agitators is connected by a cross-head *G''''*, with a vertical shaft *G'''''*, which is revolved by the well-known contrivances shown. Below the cistern *E* is a shaking or oscillating iron table *H* connected by bell-crank *H'* and rod *H''* with crank *H'''* on shaft *I*. *J* is a flat bar or connection for sustaining and conveying an oscillating motion to rake *J'*, which is stayed by rod *J''*, pivoted at either end. *C'* is a discharge tap for the solid deposits; *C''* and *C'''* are discharge taps for the waste; and *K* is a steam-supply pipe which is not used in boxes 4 and 5. The elevator cups or buckets are perforated so as to remove as little liquid as possible.

Referring to figure 4, the strong iron cistern *E* is lined inside with an amalgamated copper lining, and through the hole in its bottom is a pipe like *F*, see figure 7, but containing a second pipe *F'*, which screws into *F*, and around said pipe *F* inside the cistern is a thick copper boss *L* screwed tightly down on to an india-rubber washer *L'*. The dark lines at the bottom of the pan represent the quicksilver, and *M* the amalgam draw-off pipe. In this case the oscillating table *H* consists of an amalgamated copper plate instead of iron, as in the other boxes.

Referring to figures 4 and 6, *NNN* are harrows or rakes supported by one common framing, and attached to a rocking shaft *N'*, to which motion is imparted by rods *N''* and *N'''* from crank *N''''*, as shown.

Figures 2, 3, and 5 represent boxes marked 1, 2, 3, 4, and 5 in the plan, figure 1, and figure 4 represents the box marked 6 in the plan.

Boxes 1, 2, and 3 are supplied with my chemical solution to the level shown, and have covers fitted on them; whilst boxes 4, 5, and 6 are supplied with water to the same level, and are without covers.

The cistern *E* in box 6 is the only one that contains any quicksilver.

In the first three boxes the gold is freed from the baser metals by my chemical solution, in the fourth and fifth the auriferous material is washed of the chemical solution, and in the sixth the gold is amalgamated.

The *modus operandi* is as follows:—First of all, the boxes 1, 2, and 3 are charged with the chemical solution, and boxes 4, 5, and 6 with water, and the cistern in box 6 with quicksilver. Then steam is supplied through the pipes *K*, and the apparatus is ready for treating material. This must be supplied dry to the box *A*, from whence it is lifted by elevator *B*, and discharged down shoot *B'* into the iron cistern *E* in box 1. Here it is agitated by the agitating rods *G*, and finally finds its way down the pipe *F*, falls on to the shaking plate *H*, and then either deposits itself at the bottom of the box, there to be agitated by the rake *J'*, or is carried by the elevators *D'* and discharged through shoot *P* into box 2, where it is treated in identically the same way, and so on from box to box until it reaches box 6, where the amalgamation takes place, and the waste only falls down the pipes *F'* *F* into the bottom of this box. After these boxes have been sufficiently used they are disconnected from the driving power, and whatever deposits are found therein are removed to the rake-box (figure 6), where they are subjected to a further raking to and fro, after which the water is drawn off, and the light stuff at the top removed, while the bottom layer is conveyed to box 6 (see figure 4), and there treated in the same way as the other material subjected to its operation. The light stuff at the top is my novel pigment.

Improvements in the treatment of finely-divided auriferous material, &c.

In the event of its being desired to treat auriferous material having no arsenic or sulphur, it is only necessary to use box G, as this will effect the extraction and amalgamation of the gold.

Having thus described the nature of my invention, and the manner of performing same, I would have it understood that what I believe to be new, and therefore claim as the improvements in the treatment of finely-divided auriferous material for the extraction of gold and quicksilver, the residual product being a novel pigment, for which I am desirous of securing a patent, is—

First—The use of a solution of Roche lime and common washing-soda for the purpose of setting free the gold in auriferous material containing arsenic and sulphur.

Second—The agitators (see figure 9) working in a cistern E having a pipe F through the centre of its bottom, substantially as and for the purposes described.

Third—The inclined shaking plate H, and the oscillating rake J', supported and worked in the manner and for the purpose described.

Fourth—The cistern E, having an inner copper lining, a hole in the centre of the bottom fitted with a screwed pipe F containing another screwed pipe F', and a solid copper boss L, all combined and arranged substantially as and for the purposes described.

Fifth—The combination of the rake-box and rakes NNN with the other parts of the apparatus shown, and forming together my complete plant, for the purposes stated.

Sixth—The use of the residual products from my method of treating finely-divided auriferous material containing arsenic or sulphur, or both, as a pigment, substantially as described and explained.

In witness whereof, I, the said Edward Spencer, have hereto set my hand and seal, this eighth day of May, one thousand eight hundred and eighty-four.

Witness—

EDWD. WATERS, Melbourne, Patent Agent.

EDWARD SPENCER.

This is the specification referred to in the annexed Letters of Registration granted to Edward Spencer, the twenty-third day of June, A.D. 1884.

AUGUSTUS LOFTUS.

REPORT.

Sir,

In the matter of the application of Mr. Edward Spencer, for Letters of Registration for "Improvements in the treatment of finely-divided auriferous material for the extraction of gold and quicksilver, the residual product being a useful pigment," we have examined the specification and drawings accompanying the same, and have now the honor to report that we see no objection to the issue of Letters of Registration as prayed for.

Sydney, 17 May, 1884.
We have, &c.,

J. SMITH,

A. LEIBIUS.

The Under Secretary of Justice.

[Drawings—one sheet.]

EDW^d SPENCER'S PATENT.

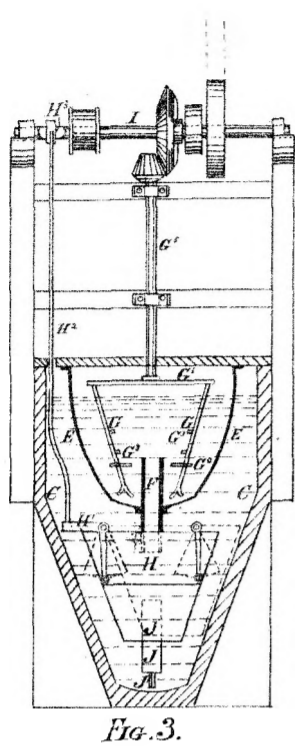


Fig. 3.

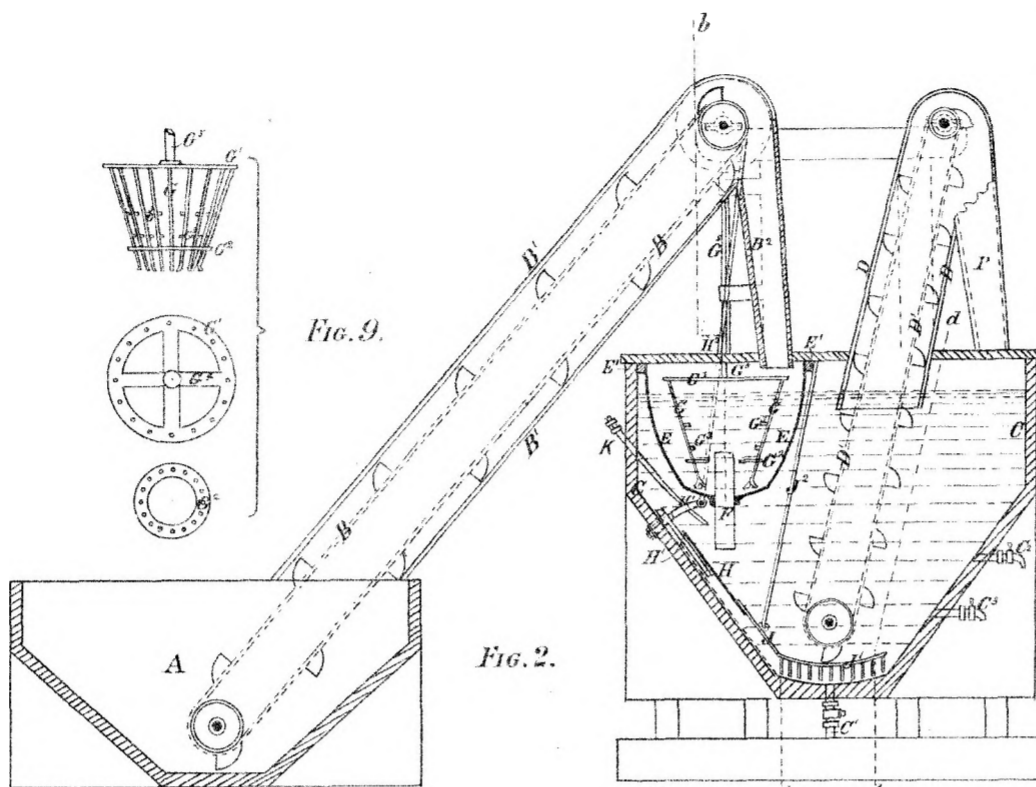


Fig. 2.

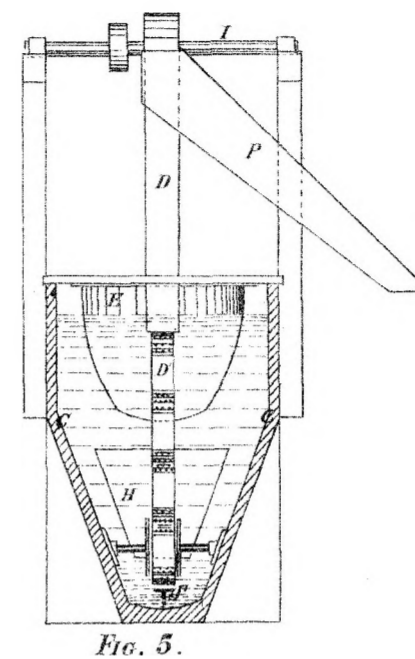


Fig. 5.

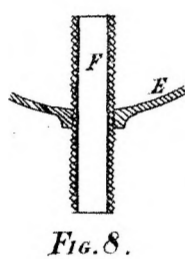


Fig. 8.

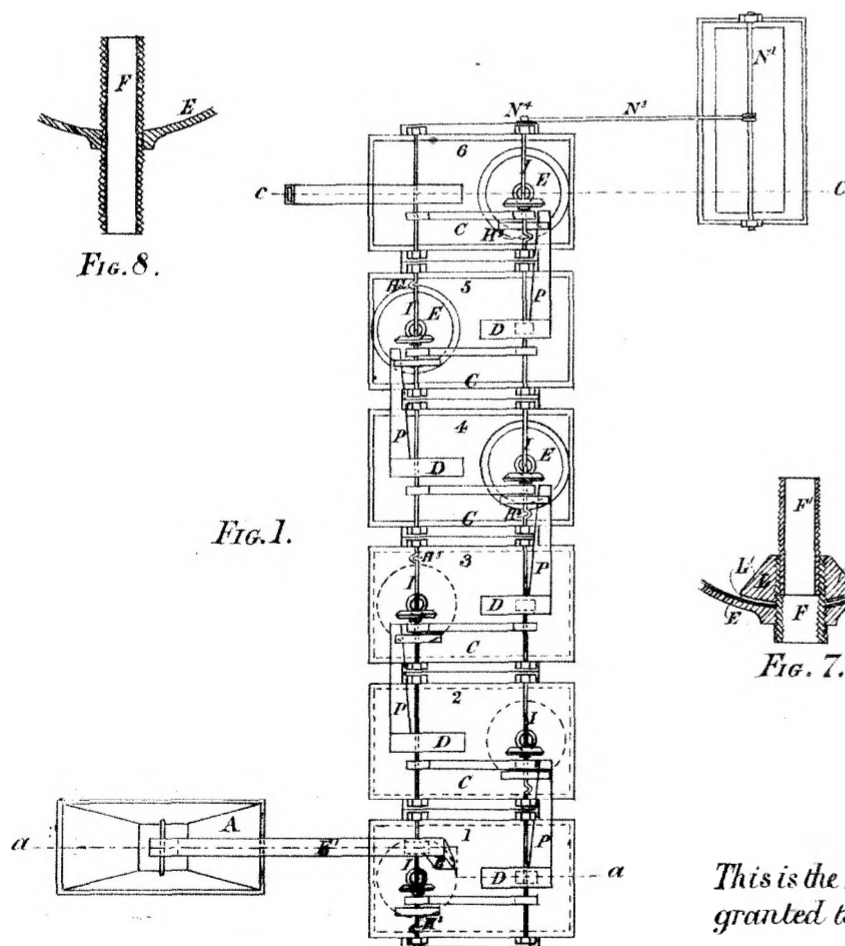


Fig. 1.

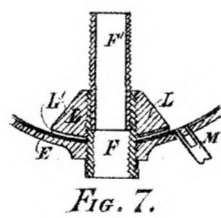


Fig. 7.

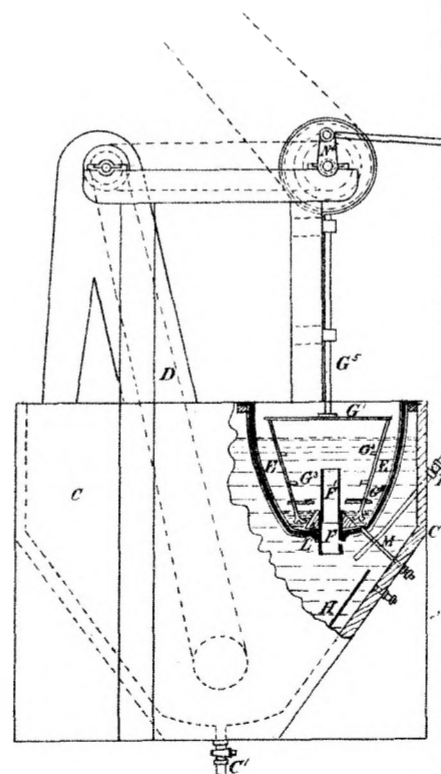


Fig. 4.

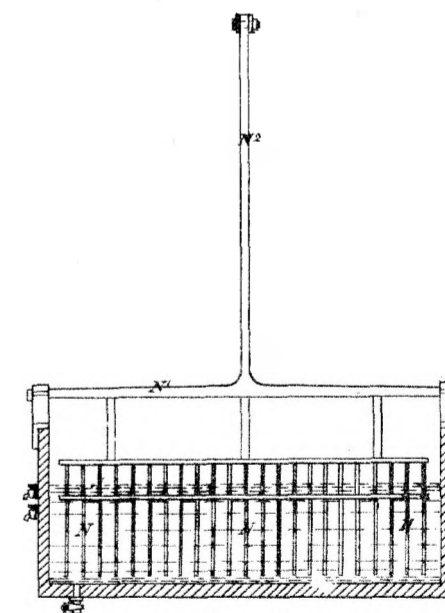
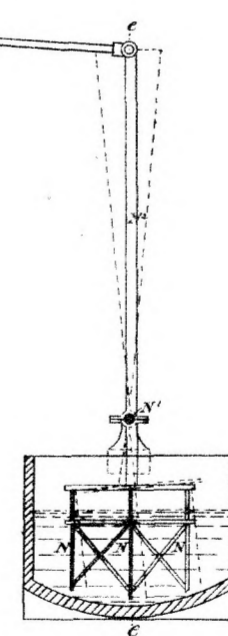


Fig. 6.

This is the Sheet of Drawings referred to in the annexed Letters of Registration, granted to Edward Spencer, the twenty-third day of June, A. D., 1884.

Augustus Loftus.

(Sig. 245.)



A.D. 1884, 23rd June. No. 1440.

AN IMPROVED PROCESS FOR THE TREATMENT OF PYRITES

LETTERS OF REGISTRATION to Conrad Icke, for Icke's Cupola Oven or Furnace for the treatment of pyrites and other ores or substances.

[Registered on the 24th day of June, 1884, in pursuance of the Act 16 Vic. No. 24.]

BY HIS EXCELLENCY THE RIGHT HONORABLE SIR AUGUSTUS WILLIAM FREDERICK SPENCER LOFTUS (commonly called LORD AUGUSTUS LOFTUS), Knight Grand Cross of the Most Honorable Order of the Bath, a Member of Her Majesty's Most Honorable Privy Council, Governor and Commander-in-Chief of the Colony of New South Wales and its Dependencies.

TO ALL TO WHOM THESE PRESENTS SHALL COME, greeting :

WHEREAS CONRAD ICKE, of Sydney, in the Colony of New South Wales, engineer, hath by his Petition humbly represented to me that he is the author or designer of a certain invention or improvement in manufactures, that is to say, of an invention entitled "Icke's Cupola Oven or Furnace for the treatment of pyrites and other ores or substances," which is more particularly described in the amended specification and the drawing which are hereunto annexed; and that he, the said Petitioner, hath deposited with the Honorable the Treasurer of the said Colony of New South Wales the sum of Twenty Pounds sterling, for defraying the expense of granting these Letters of Registration, as required by the Act of Council, sixteenth Victoria, number twenty-four; and hath humbly prayed that I would be pleased to grant Letters of Registration, whereby the exclusive enjoyment and advantage of the said invention or improvement might be secured to him for a period of fourteen years: And I, being willing to give encouragement to all inventions and improvements in the arts or manufactures which may be for the public good, and having received a report favourable to the prayer of the said Petition, from competent persons appointed by me to examine and consider the matters stated therein and to report thereon for my information, am pleased, with the advice of the Executive Council, and in exercise of the power and authority given to me by the said Act of Council, to grant, and do by these Letters of Registration grant unto the said Conrad Icke, his executors, administrators, and assigns, the exclusive enjoyment and advantage of the said invention or improvement, for and during the term of fourteen years from the date hereof; to have, hold, and exercise unto the said Conrad Icke, his executors, administrators, and assigns, the exclusive enjoyment and advantage thereof, for and during and unto the full end and term of fourteen years from the date of these presents next and immediately ensuing, and fully to be complete and ended: Provided always, that if the said Conrad Icke shall not, within three days after the granting of these Letters of Registration, register the same in the proper office in the Supreme Court, at Sydney, in the said Colony of New South Wales, then these Letters of Registration, and all advantages whatsoever hereby granted, shall cease and become void.

In witness whereof, I have hereunto set my sign manual, and have caused the present Letters of Registration to be sealed with the seal of the said Colony of New South Wales, at Government House, Sydney, in New South Wales, this twenty-third day of June, in the year of our Lord one thousand eight hundred and eighty-four.

[L.S.]

AUGUSTUS LOFTUS.

An improved process for the treatment of Pyrites.

TO ALL TO WHOM THESE PRESENTS SHALL COME: I, CONRAD ICKE, of Sydney, in the Colony of New South Wales, engineer, send greeting:

WHEREAS I am desirous of obtaining Royal Letters Patent for securing unto me Her Majesty's special license that I, my executors, administrators, and assigns, or such other persons as I or they may at any time agree with, and no others, should, and lawfully might, from time to time, and at all times, during a period of fourteen years, to be computed from the day on which this instrument is lodged in the office of the Chief Secretary, make, use, exercise, and sell, within the Colony of New South Wales and its dependencies, an invention for the extraction of gold, silver, copper, lead, and other metals from pyrites and other ores and substances, such invention to be designated "Icke's Cupola Oven or Furnace for the treatment of pyrites and other ores or substances," and which cupola oven or furnace I describe in manner hereinafter following:—

SPECIFICATION of Icke's Cupola Oven or Furnace, for raising a high temperature by the assistance of compressed air:—The oven is built with boilerplate-iron or stout sheet-iron, and lined on the inside with fire-bricks; on the outside of the first wall of plate or sheet iron is a second wall, made of sheet-iron, and which encircles the first wall to any given height. The space between the two walls forms a reservoir or cylinder for the reception of a current of common air, which is supplied by an air-pump or fan; this air is then forced in a compressed form through four, eight, or more pipes into the body of the oven.

A in the plan or drawing above referred to shows inside of oven. B, fire-bricks, or other suitable material. C shows bottom of oven, on which metals collect. D, feed-door for reception of coal, metal, or ore. E, iron door or cover to top of oven. F, pipes or iron flues, by which the hot compressed air is conveyed into the body of the oven. G shows opening for discharge of metal or slag when molten. H is the external cylinder or reservoir to receive air from pump or fan prior to its being conveyed by pipes F into oven; I, pipe through which air is conveyed into reservoir H; K, door or transparent cap for observation of internal action of oven; L, opening through which smoke and fumes are conveyed to my condensing flues, or smoke-stack, as may be required; M, valve to regulate the supply of air.

Having thus described as fully as possible the cupola oven or furnace which I now seek to patent, and which I propose using in the treatment of pyrites and other ores and substances, I now specify my claim thus—

I claim as my own invention the pattern of an improved cupola oven or furnace, as described and shown in the specification herein written, and in the drawings hereto attached, and which drawings are marked "Plan B 1."

And I certify that to the best of my knowledge and belief no person other than myself is entitled to a patent for the invention hereinbefore described, of which I believe myself to be the true and first inventor.

Pr. CONRAD ICKE,
B. O. HOLTERMANN.

This is the amended specification referred to in the annexed Letters of Registration granted to Conrad Icke, the 23rd June, A.D., 1884.

AUGUSTUS LOFTUS.

REPORTS.

Sir,

Sydney, 29 March, 1884.

In the matter of the application of Mr. Conrad Icke for Letters of Registration for "A process for the treatment of pyrites and other ores," which has been referred to us, we have given careful consideration to the specification and drawings accompanying the same, and have now the honor to report as follows:—

The specification presents eight distinct claims, four being for furnaces and flues, and four for processes connected therewith. Of the furnaces, one is the ordinary type of reverberatory furnace, and presents no feature of novelty. Another is a well-known form of furnace for cupellation. As to the flues for condensing volatile vapours, if there be any novelty about them it is not disclosed in the specification. The four claims referring to processes show no novelty whatever. There remains only the second claim, which refers to an "Improved Cupola Oven or Furnace." In this we consider there is a small amount of originality, and if Mr. Icke should think it worth while to have this one item in his specification protected by Letters of Registration we would offer no objection; but all the rest of the specification and claims must be rejected.

We have, &c.,

J. SMITH.
A. LEIBIUS.

The Under Secretary of Justice.

3 May, 1884.

MEMO.—An amended specification must be sent in, omitting the apparatus, processes, and claims that have been disallowed, and the drawings should include only the "Improved Cupola Oven or Furnace," for which, according to our report of March 29th, Letters of Registration may be granted.

J. SMITH.
A. LEIBIUS.

The Under Secretary of Justice.

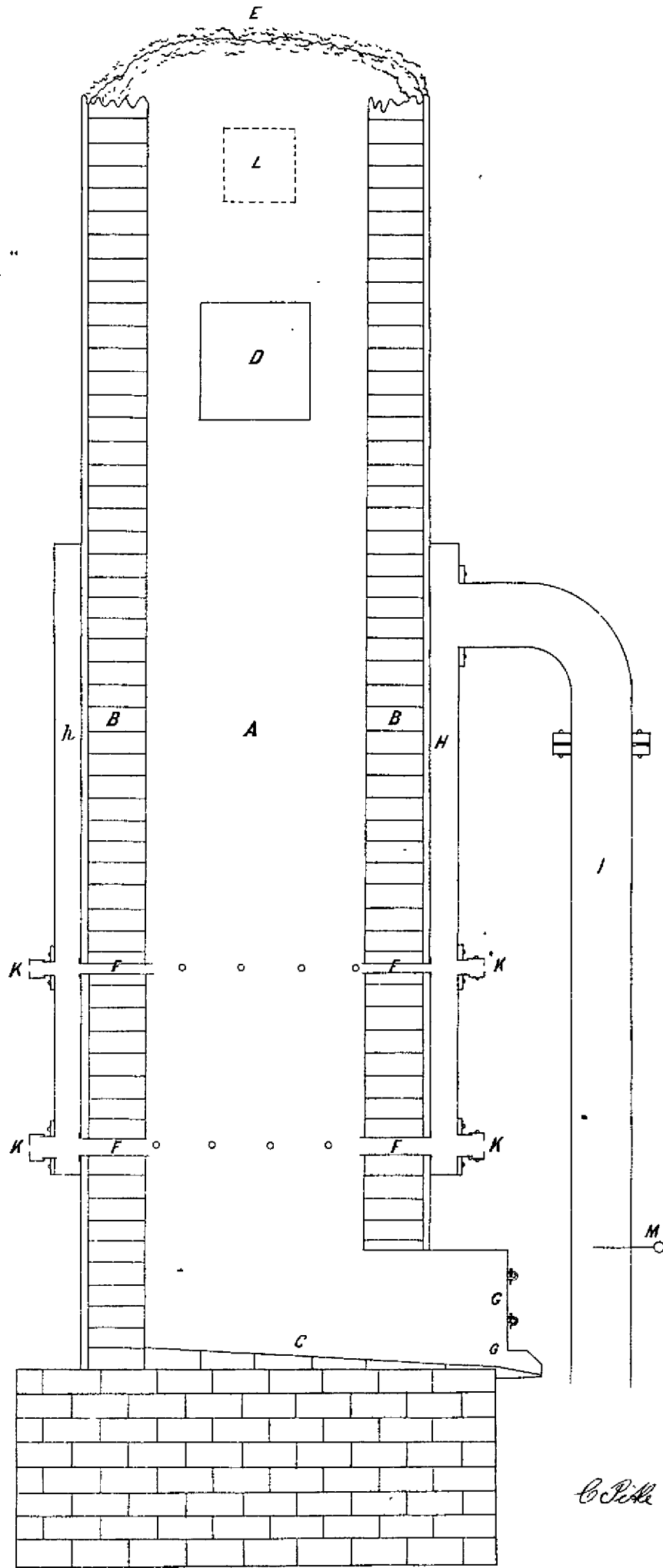
10 May, 1884.

MEMO.—We consider that Letters of Registration may now be issued on the amended specification.

J. SMITH.
A. LEIBIUS.

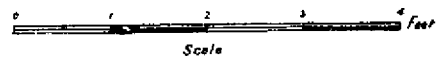
The Under Secretary of Justice.

"PLAN B.I."



This is the Drawing referred to in the annexed Letters of Registration granted to Conrad Icke, the twenty third day of June, A. D., 1884

Augustus Loftus.





A.D. 1884, 23rd June. No. 1441.

FILTRATION AND SEPARATION OF SEWAGE.

LETTERS OF REGISTRATION to The Roberts Patent Sanitary Process Company (Limited), for Improvements in the Filtration and Separation of Sewage.

[Registered on the 24th day of June, 1884, in pursuance of the Act 16 Vic. No. 24.]

BY HIS EXCELLENCY THE RIGHT HONORABLE SIR AUGUSTUS WILLIAM FREDERICK SPENCER LOFTUS (commonly called LORD AUGUSTUS LOFTUS), Knight Grand Cross of the Most Honorable Order of the Bath, a Member of Her Majesty's Most Honorable Privy Council, Governor and Commander-in-Chief of the Colony of New South Wales and its Dependencies.

TO ALL TO WHOM THESE PRESENTS SHALL COME, greeting :

WHEREAS THE ROBERTS PATENT SANITARY PROCESS COMPANY (Limited), of New Zealand, hath by its Petition humbly represented to me that it is the assignee of Thomas Roberts, of Christchurch, New Zealand, civil engineer, who is the author or designer of a certain invention or improvement in manufactures, that is to say, of an invention entitled "Filtration and Separation of Sewage," which is more particularly described in the specification which is hereunto annexed; and that the said Petitioner hath deposited with the Honorable the Treasurer of the said Colony of New South Wales the sum of Twenty Pounds sterling, for defraying the expense of granting these Letters of Registration, as required by the Act of Council, sixteenth Victoria, number twenty-four; and hath humbly prayed that I would be pleased to grant Letters of Registration whereby the exclusive enjoyment and advantage of the said invention or improvement might be secured to him for a period of fourteen years: And I, being willing to give encouragement to all inventions and improvements in the arts or manufactures which may be for the public good, and having received a report favourable to the prayer of the said Petition from competent persons appointed by me to examine and consider the matters stated therein and to report thereon for my information, am pleased, with the advice of the Executive Council, and in exercise of the power and authority given to me by the said Act of Council, to grant, and do by these Letters of Registration grant unto the Roberts Patent Sanitary Process Company (Limited) aforesaid and its assigns, the exclusive enjoyment and advantage of the said invention or improvement, for and during the term of fourteen years from the date hereof; to have, hold, and exercise unto The Roberts Patent Sanitary Process Company (Limited) aforesaid and its assigns, the exclusive enjoyment and advantage thereof, for and during and unto the full end and term of fourteen years from the date of these presents next and immediately ensuing, and fully to be complete and ended: Provided always, that if The Roberts Patent Sanitary Process Company (Limited) aforesaid shall not, within three days after the granting of these Letters of Registration, register the same in the proper office in the Supreme Court, at Sydney, in the said Colony of New South Wales, then these Letters of Registration, and all advantages whatsoever hereby granted, shall cease and become void.

In witness whereof, I have hereunto set my sign manual, and have caused the present Letters of Registration to be sealed with the seal of the said Colony of New South Wales, at Government House, Sydney, in New South Wales, this twenty-third day of June, in the year of our Lord one thousand eight hundred and eighty-four.

[L.S.]

AUGUSTUS LOFTUS.

Filtration and Separation of Sewage.

SPECIFICATION of an invention for the Filtration and Separation of Sewage.

THE said invention is a process by which all excreta and sewage may be filtrated in a manner so that the liquid portions thereof are completely separated from the solid portions thereof, and may be at the same time disinfected and deodorised.

Although the said process can be made applicable to all sewage matter, it is intended specially for application to the treatment of human excremental sewage by means of what is generally termed or known as a "pan or pail system," in manner following:—The closet pans or receptacles of the excremental matters, being made of any suitable material, may be of any convenient size and form, but preferably of cylindrical shape, and each with the bottom of less diameter than the top. Such pans or receptacles, of whatever material or materials made or composed, must each and in every case be perforated with a sufficient number of holes in the sides and bottom to permit liquid matter to pass freely from them. Such said pans or receptacles being perforated as above described, are to be lined throughout with the "filtrating lining," hereinafter specified, such filtrating lining being made and applied in one or more sheets or pieces for each pan or receptacle; and every such pan or receptacle is to be relined with a new filtrating lining of the same description as above referred to immediately after every discharge of the matter that may have accumulated therein, when such pan or receptacle may be required for further use of a like nature. The filtration is to be obtained and effected by the use of a material or substance herein referred to as the "filtrating lining," and which is to be manufactured or made out of straw, grass, or any other suitable fibrous matters, such manufacture consisting of boiling, and otherwise converting into a somewhat coarse pulp, the said straw, grass, or any other suitable fibrous matters, and after impregnating such pulp with oil of eucalyptus, or with permanganate of potash, or with carbolic acid, or with any other sufficient antiseptic fluid or substance, to press the same into sheets of a quarter of an inch in thickness (more or less), the thickness being made proportionate to the size of the pans or receptacles in which the said sheets may be intended to be used, and then dried. The filtrated liquid, or effluence, may either pass into any other suitable receptacles for same, placed underneath, or contiguous to, or connected with, any such of the aforesaid pans or receptacles for faecal matter or sewage, and afterwards disposed of on adjoining land or otherwise, as may be most convenient or desirable; or it may fall into a suitable trough or open channel placed or made underneath the closet pan or receptacle, and thence be conveyed to where it may be desired, either by a continuation of such trough or open channel, or by a pipe connecting with same. The manner of disposing of the said liquid will depend chiefly on the following considerations, namely:—

1. The nature of the site and arrangement of the premises where it originates or is made.
2. Local circumstances and means of drainage.
3. The purpose (if any) to which it may be required to apply such liquids.

The solid faecal matter that will become retained in the pans or receptacles for same will be in a form that may be readily converted into a valuable marketable manure.

F. E. AMINNITT,

Attorney for The Roberts Patent Process Company (Limited).

Witness—

THOS. J. SOUTHERN, Clerk to Messrs. Want, Johnson, & Scarvall, solicitors, 60, Pitt-street, Sydney.

This is the specification referred to in the annexed Letters of Registration granted to The Roberts Patent Sanitary Process Company (Limited), the twenty-third day of June, A.D. 1884.

AUGUSTUS LOFTUS.

REPORT.

Sir,

In the matter of the application of The Roberts Patent Sanitary Process Company (Limited), for Letters of Registration for an invention for "The Filtration and Separation of Sewage," which has been referred to us, we have examined the specification accompanying the same, and have now the honor to report that we see no objection to the issue of Letters of Registration as prayed for.

We have, &c.,

J. SMITH,

A. LEIBIUS.

The Under Secretary of Justice.



A.D. 1884, 23rd June. No. 1442.

LOCKING AND INTERLOCKING RAILWAY SIGNALS AND POINTS.

LETTERS OF REGISTRATION to Stanley Charles Cuthbert Currie and Illius Augustus Timmis for Improvements in the means for working and locking and interlocking Railway Signals and Points.

[Registered on the 24th day of June, 1884, in pursuance of the Act 16 Vic. No. 24.]

BY HIS EXCELLENCY THE RIGHT HONORABLE SIR AUGUSTUS WILLIAM FREDERICK SPENCER LOFTUS (commonly called LORD AUGUSTUS LOFTUS), Knight Grand Cross of the Most Honorable Order of the Bath, a Member of Her Majesty's Most Honorable Privy Council, Governor and Commander-in-Chief of the Colony of New South Wales and its Dependencies.

TO ALL TO WHOM THESE PRESENTS SHALL COME, greeting:

WHEREAS STANLEY CHARLES CUTHBERT CURRIE, of 22, Clarges-street, Piccadilly, gentleman, and ILLIUS AUGUSTUS TIMMIS, of 2, Great George-street, in the city of Westminster, civil engineer, both in the county of Middlesex, England, have by their Petition humbly represented to me that they are the authors or designers of a certain invention or improvement in manufactures, that is to say, of an invention entitled "Improvements in the means for working and locking and interlocking Railway Signals and Points," which is more particularly described in the specification and the sheet of drawings which are hereunto annexed; and that they, the said Petitioners, have deposited with the Honorable the Treasurer of the said Colony of New South Wales the sum of Twenty Pounds sterling, for defraying the expense of granting these Letters of Registration, as required by the Act of Council, sixteenth Victoria, number twenty-four; and have humbly prayed that I would be pleased to grant Letters of Registration, whereby the exclusive enjoyment and advantage of the said invention or improvement might be secured to them for a period of fourteen years: And I, being willing to give encouragement to all inventions and improvements in the arts or manufactures which may be for the public good, and having received a report favourable to the prayer of the said Petition, from competent persons appointed by me to examine and consider the matters stated therein and to report thereon for my information, am pleased, with the advice of the Executive Council, and in exercise of the power and authority given to me by the said Act of Council, to grant, and do by these Letters of Registration grant unto the said Stanley Charles Cuthbert Currie and Illius Augustus Timmis, their executors, administrators, and assigns, the exclusive enjoyment and advantage of the said invention or improvement, for and during the term of fourteen years from the date hereof; to have, hold, and exercise unto the said Stanley Charles Cuthbert Currie and Illius Augustus Timmis, their executors, administrators, and assigns, the exclusive enjoyment and advantage thereof, for and during and unto the full end and term of fourteen years from the date of these presents next and immediately ensuing, and fully to be complete and ended: Provided always, that if the said Stanley Charles Cuthbert Currie and Illius Augustus Timmis shall not, within three days after the granting of these Letters of Registration, register the same in the proper office in the Supreme Court, at Sydney, in the said Colony of New South Wales, then these Letters of Registration, and all advantages whatsoever hereby granted, shall cease and become void.

In witness whereof, I have hereunto set my sign manual, and have caused the present Letters of Registration to be sealed with the seal of the said Colony of New South Wales, at Government House, Sydney, in New South Wales, this twenty-third day of June, in the year of our Lord one thousand eight hundred and eighty-four.

[L.S.]

AUGUSTUS LOFTUS.

Locking and Interlocking Railway Signals and Points.

SPECIFICATION of STANLEY CHARLES CUTHBERT CURRIE, of 22, Clarges-street, Piccadilly, gentleman, and ILLIUS AUGUSTUS TIMMIS, of 2, Great George-street, in the city of Westminster, civil engineer, both in the county of Middlesex, England, for an invention entitled, "Improvements in the means for working and locking and interlocking Railway Signals and Points."

THE objects of this invention are to provide means whereby railway signals (of whatever description, semaphore or otherwise) can be worked by electro-magnets, safely, simply, and economically, and locked and interlocked with points.

With these objects in view we take ordinary signal-posts and signal-arms, and we pull the signal-arms down free "line clear" by means of an electro-magnet. Where signals are made to show three positions ("danger," "caution," and "line clear") we use a double magnet. One part of the magnet pulls the signal-arm to "caution," and the other part pulls it to a position signifying "line clear." The three positions may be exhibited at any suitable angles; but we have shown the old "horizontal," "45°," and "vertical," as illustrating respectively "danger," "caution," and "line clear."

We not only pull the arms down, "caution" or "line clear," but we hold them down by the armature of the electro-magnet remaining in contact (or practically in contact) with its bobbin, and when they are in contact the main or "lowering" current is reduced from 5 or 10 amperes (or whatever other ampere current is used) to a very much less current. As a rule we find 2 ampere more than sufficient to hold the armature and bobbin together and the signals lowered.

By this means the expenditure of electricity is so reduced that, in working with low electro motive force magnets and accumulator batteries, the electrical horse-power used per signal per twenty-four hours is not more than .02. The normal position of every signal is thus, as it should be, at "danger," and the signals (whether semaphores or ground-lamps, or of any other form) are pulled down "caution" or "line clear," and held down by a continuous current of electricity, and, if there is any break in the current, the signals go to "danger" automatically, and are locked automatically, without the aid of catches, springs, or extra magnets. The rail treadles, which are used in station to station signalling, break and make the current as required, and so do the "receiving" and "transmitting" instruments in the signal-boxes. The action of every magnet and its signal is recorded by a return small current from the magnet actuating a repeater-needle in the signal-box, which records the travel of the armature and the completion of its travel, and the breaking of its contact with the bobbin. These arrangements are made practicable by the use of a continuous maximum or reduced current of electricity, which is one main feature in this invention, and which lowers and holds all signals at "caution" or "line clear" without the aid of any catches or extra parts, springs, extra magnets, &c.; and yet, if anything happens to the electrical or mechanical parts, the signals go to "danger" automatically.

The second part of this invention relates to the automatic locking of the signal-arms (or ground-lamps, &c.) when at "danger," without the aid of catches, springs, extra magnets, &c., thus simplifying and perfecting the working of railway signals. The accompanying drawings explain how this is carried out.

Fig. 1 represents the signal-arm A at "danger" fixed on the spindle B and actuated by the crank R, which is connected to the bell-crank T' by the rod Q at C and D. The bell-crank T' revolves upon the centre G, and the centre E, at the other extremity of the bell-crank, is on the line L Z. This centre E is connected to the centre I by the rod P, and the centre I is connected to the spindle H by the lever-arm X, which is fastened to and revolves with the spindle H. The spindle H is supported by the bracket J, and on it and revolving with it are the lever-arm X and disc O. This disc may be substituted by a bell-crank or other arrangement. There is a chain or wire or rope U fastened to the disc O and wound partially round it, and the other end of the chain or wire or rope is fastened to the magnet M, and is actuated by it; of course it can be actuated by any other means (manual, pneumatic, or otherwise). The three centres E, H, and I, are, it will be noted, in the line L Z. In order to lower the signal-arm A the centre C of the crank R has to describe the arc C C', and the centres D and E of the bell-crank T' describe the arcs D S and E F respectively; but this cannot be done as long as the three centres E, H, I are in the line L Z, because the centre E is attached to the centre I by the rod P.

In order then to lower the signal-arm the centre I of the lever-arm X must be raised above the line L Z and made to describe the arc I K (see fig. 2), and this is done by the chain or rope U revolving the disc O and bringing the lever-arm X, and rod P, and bell-crank T' into the positions shown in fig. 2.

It is then evident that as long as the centres E, H, and I are in the line L Z it is impossible, by any pull of the rod Q on the centre D, to move the bell-crank T', and thus the signal-arm A, when it is brought to a position of "danger," as shown in fig. 1, by the weighted lever W, is automatically locked by mechanical means, without the aid of any catches or electrical methods. We prefer to allow the weighted lever to fall rather below the position shown in fig. 1, and this is regulated by the stop V, in which case the centre I falls somewhat below the line L Z, and any pull on the centre D of the bell-crank T' pulls the weighted lever W still more firmly against the stop V, and increases the efficiency of the locking of the signal-arm A at "danger."

Figs. 3 and 4 show a different form of signal, in which the arm A is balanced in the centre G, and thus any accidental weight, such as an accumulation of snow on the arm, does not disturb it or tend to depress it.

Referring to the drawing—Figs. 3 and 4, the arm A, pivot G, centre E, rod P, centre I, spectacles W, stop V, disc U, spindle H, bobbin M, armature N, are parts of the signal-post and magnet and fittings.

When a maximum or "lowering" current of electricity is passed through the magnet it causes the armature N to be attracted to the bobbin M. The disc U revolves by means of the chain (or wire or rope) which is partly wound round it. The disc U is fixed to the spindle H, and on the opposite side of posts is fixed on the same spindle H the spectacles W, which carry the pin l. Then, on the disc revolving in the direction of the arrow, the spectacles rise, and the centre I describes the arc I K, which carries with it the rod P. But the rod P is attached to the centre E, and this centre is thus caused to traverse the arc E F, and the arm then assumes the position shown in fig. 4. On the current being broken, either accidentally

Locking and Interlocking Railway Signals and Points.

accidentally or otherwise, the armature is released, and the weight of the spectacles brings the arm back to the horizontal position. And it must be especially pointed out that when the spectacles have fallen back to their normal position and the arm is horizontal (fig. 3) the three centres E, H, and I are in one straight line L O, and therefore the arm is locked, and cannot possibly be moved until the spectacles are raised, by the armature N being attracted to and moving towards the bobbin M.

On referring to fig. 3 it will be seen that the arm can be made to assume three positions (two positions being indicated by dotted lines) *i.e.* :—

1. Horizontal position, indicating "danger."
2. Angle of 45° position, indicating "go ahead cautiously."
3. Vertical position, indicating "line clear."

The last two positions are obtained by the use of the double magnet, fig. 5, which takes the place on the post of the single magnet, figs. 3 and 4, by means of which the arm can be brought to position No. 2 and held there firmly, or to position No. 3 and held there. The arm is allowed to fall back to "danger" in the same manner as before described, and is there mechanically locked, without the aid of catches, springs, or extra magnets.

We would specially point out here, having described the way the signals are worked by the magnets, by a continuous current which is used at its maximum to lower the signals, that when the armature and bobbin of the magnets come together a resistance is switched in, which reduces the "lowering" to the "retaining" current. Any suitable kind of resistances may be used, but we find a small incandescent lamp to answer the purpose well. This incandescent lamp (or other resistance) may be switched in in a very great number of ways, but we generally use the arrangement shown in fig. 6. The lever Y is pivoted on the pin R, and is held back at X or forward at Z by the spring S acting against the surfaces A and A'. When the lever Y is back there is no current running through the magnet, and hence its signal is locked; but the contact pieces B B (fig. 6) are connected by the strip C, and the current is enabled to go through to the other signals, and, on the other hand, when the lever Y goes to Z or Z', B B are disconnected, but when it is forward at Z' the maximum "lowering" current is running, and the signalman has to hold it there till he sees the signal-arm come down "caution" or "line clear," or till he sees the repeater-needle, which is in the signal-box N, fig. 6, indicate that the signal is down.

There may be a repeater or "tell-tale" for each signal, but this is not necessary, as no two signals are down simultaneously, and if any number are lowered one after the other one repeater is enough. The repeater, which may be of any suitable shape, is actuated, by preference, by an earth current, though it may be worked by separate wires. When the signal arm is being lowered the maximum or "lowering" current, which is regulated by a variable resistance in the cabin, runs through the contact piece L, and as soon as it is lowered the signal-man lets go the lever, and it assumes the position Z, and is held there by the spring S. The current then runs through the contact piece H, and in this circuit there is the resistance before-mentioned, which reduces the "lowering" current to the "retaining current." This "retaining" current holds the signal down at a minimum of cost, and this reduction of current is one main feature in our invention.

Having described the way in which the electric current is used to lower signals (arms, lamps, &c.) and to hold them down, and how the signalman has a check on all such operations by a "repeater" in his cabin; and how the lever Y, fig. 6, controls both the "lowering" and "retaining" currents, and also the breaking of the current by being put back to X, fig. 6; and having described how the signal-arm goes to "danger" when the current is broken, and is automatically locked there, we would point out that in our system of station to station signalling, the continuous maximum current and the reduced current are of immense value when worked in conjunction with rail-treadles and "transmitting" and "receiving" instruments in the cabins, as a thorough and complete control is established over all signals by two or more signalmen, at different cabins, acting in conjunction with passing trains.

The various details are capable of an almost infinite variety of arrangement and parts, but we claim—

The use of a continuous maximum "lowering" electric current, and its reduction to a continuous minimum "retaining" electric current, for actuating signal-arms (ground-lamps, &c.) in conjunction with the arrangement for locking them at "danger," substantially as and for the purposes hereinbefore described.

In witness whereof, we, the said Stanley Charles Cuthbert Currie and Illius Augustus Timmis have hereunto set our hands and seals, this twenty-ninth day of February, in the year of our Lord one thousand eight hundred and eighty-four.

STANLEY C. C. CURRIE.
I. A. TIMMIS.

Witnesses—

F. G. EDWARDS, 2, Great George-street, S.W.
S. E. GUNSON, 13, Farleigh Road, Stoke, Newington, London.

This is the specification referred to in the annexed Letters of Registration granted to Stanley Charles Cuthbert Currie and Illius Augustus Timmis, the twenty-third day of June, A.D. 1884.

AUGUSTUS LOFTUS.

REPORT.

Sir,

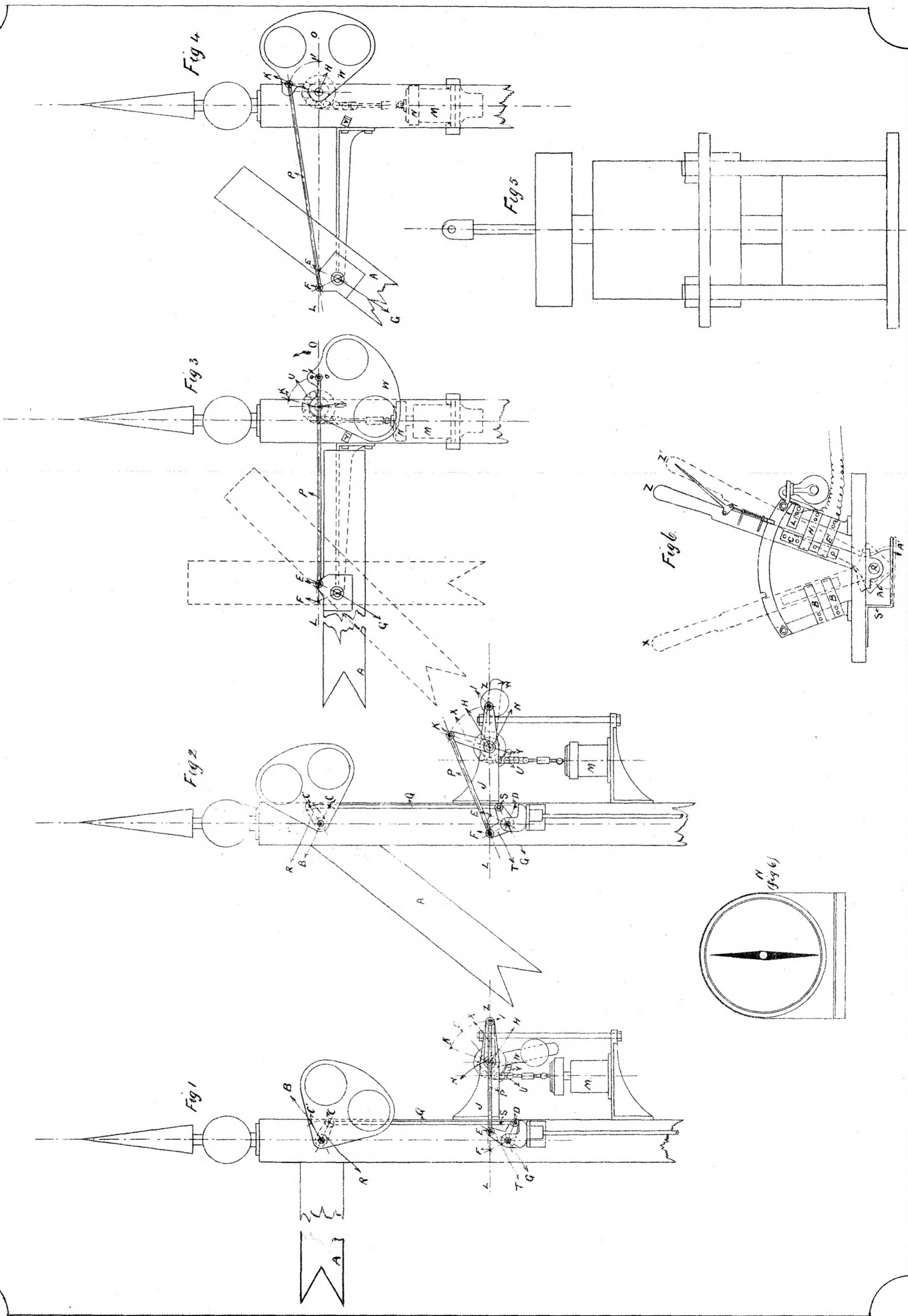
Sydney, 14 May, 1884.

In reference to your B.C. of 30th ultimo, forwarding a Petition from Messrs. Currie and Timmis for Letters of Registration for an invention entitled "Improvements in the means for working and locking and interlocking railway signals and points," we have the honor to report that, having examined the plan and specification accompanying the Petition, we are of opinion that the prayer of the Petitioners should be granted.

We have, &c.,

JOHN WHITTON.
E. O. MORIARTY.

The Under Secretary of Justice.



This is the Sheet of Drawings referred to in the annexed Letters of Registration granted to Stanley Charles Hubbard Currie, and Jltias Augustus Loftus, the twenty third day of June A.D. 1884

AUGUSTUS LOFTUS.



A.D. 1884, 23rd June. No. 1443.

AN IMPROVED METHOD OF GENERATING HEAT.

LETTERS OF REGISTRATION to Moritz Honigmann, for an Improved Method of Generating Heat, and an Improved Apparatus for carrying such method into effect.

[Registered on the 24th day of June, 1884, in pursuance of the Act 16 Vic. No. 24.]

BY HIS EXCELLENCY THE RIGHT HONORABLE SIR AUGUSTUS WILLIAM FREDERICK SPENCER LOFTUS (commonly called LORD AUGUSTUS LOFTUS), Knight Grand Cross of the Most Honorable Order of the Bath, a Member of Her Majesty's Most Honorable Privy Council, Governor and Commander-in-Chief of the Colony of New South Wales and its Dependencies.

TO ALL TO WHOM THESE PRESENTS SHALL COME, greeting :

WHEREAS MORITZ HONIGMANN, of Achen, in Germany, gentleman, hath by his Petition humbly represented to me that he is the author or designer of a certain invention or improvement in manufactures, that is to say, of an invention entitled "An Improved Method of Generating Heat, and an Improved Apparatus for carrying such method into effect," which is more particularly described in the specification and the drawing which are hereunto annexed ; and that he, the said Petitioner, hath deposited with the Honorable the Treasurer of the said Colony of New South Wales the sum of Twenty Pounds sterling, for defraying the expense of granting these Letters of Registration, as required by the Act of Council, sixteenth Victoria, number twenty-four ; and hath humbly prayed that I would be pleased to grant Letters of Registration, whereby the exclusive enjoyment and advantage of the said invention or improvement might be secured to him for a period of fourteen years : And I, being willing to give encouragement to all inventions and improvements in the arts or manufactures which may be for the public good, and having received a report favourable to the prayer of the said Petition, from competent persons appointed by me to examine and consider the matters stated therein and to report thereon for my information, am pleased, with the advice of the Executive Council, and in exercise of the power and authority given to me by the said Act of Council, to grant, and do by these Letters of Registration grant unto the said Moritz Honigmann, his executors, administrators, and assigns, the exclusive enjoyment and advantage of the said invention or improvement, for and during the term of fourteen years from the date hereof ; to have, hold, and exercise unto the said Moritz Honigmann, his executors, administrators, and assigns, the exclusive enjoyment and advantage thereof, for and during and unto the full end and term of fourteen years from the date of these presents next and immediately ensuing, and fully to be complete and ended : Provided always, that if the said Moritz Honigmann shall not, within three days after the granting of these Letters of Registration, register the same in the proper office in the Supreme Court, at Sydney, in the said Colony of New South Wales, then these Letters of Registration, and all advantages whatsoever hereby granted, shall cease and become void.

In witness whereof, I have hereunto set my sign manual, and have caused the present Letters of Registration to be sealed with the seal of the said Colony of New South Wales, at Government House, Sydney, in New South Wales, this twenty-third day of June, in the year of our Lord one thousand eight hundred and eighty-four.

[L.S.]

AUGUSTUS LOFTUS.

Improved Method of Generating Heat.

SPECIFICATION of MORITZ HONIGMANN, of Aachen, in Germany, gentleman, for an invention entitled "An Improved Method of Generating Heat, and an Improved Apparatus for carrying such method into effect."

My improved method of generating heat consists primarily in the use of heated brine as the heating agent. It is based on the fact, that a solution of any kind of salt has a higher boiling point than that of water, and is able to condense and to absorb steam as cold water does, notwithstanding the higher temperature of the solution or brine. A solution of hydrate of soda in water possesses a prominent capacity in this respect, and I use it in preference, but not to the exclusion of solutions of other salts. The capacity of condensing and fully absorbing steam depends on the boiling point of the brine which varies with the degree of its concentration; for instance, a brine containing 100 parts (in weight) of hydrate soda, and 10 parts of water has its boiling point at 256 degrees centigrade (472 degrees Fahrenheit), equivalent to a steam pressure of 43 atmospheres; a brine of 100 parts of hydrate of soda and 100 parts of water has its boiling point at 141 degrees centigrade (291 degrees Fahrenheit), equivalent to a steam pressure of 3.3 atmospheres; and a brine containing 100 parts of hydrate of soda and 450 parts of water has its boiling point at 106 degrees centigrade (222 degrees Fahrenheit), equivalent to a steam pressure of 0.27 atmospheres.

A sufficiently strong solution of hydrate of soda in water therefore is able to condense and totally absorb steam, even if the former has a temperature of 150 degrees to 200 degrees centigrade (299 degrees to 392 degrees Fahrenheit). By absorbing the steam the brine is raised in its temperature, and it is to be remarked that there are two different processes going on, a physical and a chemical one. By the physical process the heat carried by the waste steam is set free, when it is absorbed. The chemical process consists of the delusion of the brine by which the heat is set free, which was absorbed by the brine when its concentration took place in a heated covered pan.

The absorbing capacity of the brine will cease when the entering steam has a temperature equal to that of the boiling point of the brine, or when the brine is so much diluted that its boiling point is equal to that of the entering steam.

To illustrate my invention I will show how it can be applied to the generation of steam in what I call my fireless boiler.

Referring to the annexed drawing, a common steam-boiler A is inserted into a vessel B, which is water-tight, but not necessarily steam-tight. To the boiler A are fixed on its lower part a number of pipes a, say 90 to 100, or more, which are for the purpose of increasing the surface of the boiler, and which are in connection with the interior of the boiler A, but closed on the ends. This latter is about three-fourths filled with hot water, and the vessel B is about half-filled with brine as mentioned above. A steam-pipe a' connects the top of the boiler A with the steam-engine, and another pipe b connects the waste steam outlet of the engine with the vessel B. This pipe passes through the cover of the latter, and forms near the bottom one or more coils C, having small holes on the inner side, through which the waste steam is ejected into the brine in the shape of fine jets. During the time the steam-engine is going all waste steam is ejected into the brine, the temperature of which is raised, and as a necessary consequence the temperature in the boiler is raised and steam generated, so that the heat which has left the boiler carried by the steam which feeds the engine passes through the engine cylinders and returns (so far as it is not lost by radiation, labour executed, &c.) with the waste steam into the brine in the vessel B, and is, together with the heat generated by the dilution of the brine, transmitted through the boiler-plates to the water in the boiler A for again generating steam. By this process a part of the water in the boiler A passes (in the shape of steam) through the engine into the vessel B, where it mixes with the brine and lowers both its degree of concentration and its boiling temperature. After a certain time, which can be extended to several hours, so much water finds its way from the boiler A into the vessel B, as to reduce the boiling point of the brine to the temperature of the waste steam, and this is the point where the brine becomes unfit for absorbing steam of the same pressure as before. To further work the engine it is necessary, either to replace the diluted brine by some of higher strength or to increase its strength by dissolving solid salt in it, or else to work with steam of lower pressure.

A glance over the boiling temperatures of some soda brines of different strength will show the nature of the whole process. For instance, if the vessel B is charged with brine of 185 degrees to 200 degrees centigrade (365 degrees to 392 degrees Fahrenheit), boiling temperature, the process may be started with water in the boiler A of 166 degrees centigrade (330.8 degrees Fahrenheit), equivalent to 6 atmospheres pressure, and can be continued till the brine is so much diluted by the waste steam that its boiling point has been lowered to 166 degrees centigrade (330.8 degrees Fahrenheit). The brine then becomes unable to absorb all the waste steam, part of it therefore must escape uncondensed, and the other part which is absorbed by the brine cannot supply the latter with such an amount of heat as is required for keeping the pressure of steam in the boiler up to six atmospheres. Nevertheless, the process can be continued if the tension of the steam, and thereby the temperature is lowered,—for instance, to three atmospheres, equivalent to 141 degrees centigrade (291 degrees Fahrenheit). The brine then is able to again absorb waste steam, till it is so much diluted that its boiling point falls to 141 degrees centigrade (291 degrees Fahrenheit), and so forth.

This shows that the steam generated in the boiler can be of very high or of low pressure, dependent on the strength of the brine. If high pressure is used, say of fifteen to sixteen atmospheres (225 to 240 lbs. per square inch) or more (as in locomotive engines), the boiler A is supplied with water from another stationary boiler under similar pressure. But as the actual pressure of steam in the cylinders of an engine does not usually exceed four or five atmospheres it is not necessary to use a second boiler. If the water contents of the soda brine is about 20 to 25 per cent., the boiling point of this brine is equal to about 210 degrees centigrade (410 degrees Fahrenheit), and if the boiler A is supplied with hot water of 80 to 90 degrees centigrade (176 to 194 degrees Fahrenheit) without any pressure, steam is generated as soon as the hot brine (also without pressure as being below its boiling point) enters the vessel B, and the engine can start working. A second boiler, therefore, can be dispensed with, as it is sufficient to have a hot water vessel heated by the off heat of the pans in which the brine is (without pressure) generated and the diluted brine concentrated. It may be mentioned that the temperature of the brine in
vessel

Improved Method of Generating Heat.

vessel B does not exceed that of the water in the boiler A by more than 6 degrees to 10 degrees centigrade (10 degrees to 18 degrees Fahrenheit). The annexed sketch shows one shape only in which the boiler can be constructed, but any other form can be adopted,—for instance, the vessel for the brine can form the interior part inserted into the boiler; boiler and brine vessel can be arranged in horizontal instead of vertical position; the boiler can be a tubular one, and so on. Furthermore, the steam-pipe *a'* leading the steam to the engine, &c., can be bent down into the brine vessel and form several coils submerged in the hot brine, whereby the steam is dried and superheated.

My process is also applicable to existing boilers and engines, and for drying and superheating steam generally. In such case a coil of steam-pipe lying in a vessel filled with brine is inserted between boiler and engine, and a small quantity of waste steam of the engine is injected into the brine.

A similar arrangement can be made use of in case superheated steam is to be used for drying or heating air or other substances.

To show the usefulness of my invention, I state the following, viz. :—

1. The pressure in the boiler is constant during the whole process, and the engine is always working with full power, so that the objectionable regulating is done away with, because the engine itself regulates the generation of the quantity of steam required. When an increase of power is wanted a larger quantity of steam is used, and the waste steam increases at the same ratio, thereby generating a larger quantity of steam in the boiler. In many cases an engine-driver is therefore not required.

2. The difference between the temperature of the water and that of the brine is very little, 6 degrees to 10 degrees centigrade (10 degrees to 18 degrees Fahrenheit), consequently the material of the boiler is not exposed to the enormous heat of burning fuel as common boilers are, and so the main source of danger (insufficient feeding with water and overheating of the boiler-plates to red-heat) is avoided, and the construction of the boiler consequently rendered simple and cheap.

3. The brine vessel has to sustain no pressure whatever, and can be of the simplest and cheapest construction.

4. The condensation and absorption of the waste steam is complete, and the application of my process to any engine offers all the benefits of a condenser.

5. The boiler works without fire and without expelling fire-gases, smoke, half burnt fuel, or ashes.

6. Engines supplied with steam by my boiler work absolutely noiseless; no steam is ejected into the air; the condensation of the waste steam in the brine takes place without any noise, even if large quantities of condensing water enters the brine suddenly.

7. Engines supplied with steam by my boiler can be of the simplest construction; it is not necessary to use complicated expansion gear to prevent waste of fuel, because all heat of the waste-steam is made use of.

8. Locomotive engines supplied with my boiler excel by their simplicity, absence of danger, smoke, waste-steam, and noise, and by their cheapness in using fuel, and in repair. They can be driven by one man only. When ascending steep gradients the engine runs with the same speed as on level ground, because the engine itself automatically demands and regulates the generation of the steam it requires.

9. In using my process for superheating steam a great economy is effected without the danger usually attached to such process, and with the greatest accuracy.

10. My process can be applied to existing steam engines as the cheapest condenser obtainable, especially where no large supply of condensing water is available.

11. The heat which is used in my process is generated under most favourable conditions, by concentrating and heating brine and water mostly under no pressure, whereby the heating power of the fuel can be used at the highest degree. The cheapest fuel can be used.

12. There is no loss of salt, as the brine is never exposed to any pressure where leaking may happen.

Having thus described the nature of this invention, and the manner of performing same, I would have it understood that what I believe to be new, and therefore claim, is—

First—The use of heated brine of a high boiling temperature for absorbing and condensing steam, and thereby producing heat in such brine, for generating, drying, and superheating steam, drying, and heating air and other substances, substantially as herein described and explained.

Second—The combination and arrangement of parts forming my fireless boiler, substantially as herein described and explained, and as illustrated in my drawing.

In witness whereof, I, the said Moritz Honigmann, have hereto set my hand and seal, this twenty-first day of April, one thousand eight hundred and eighty-four.

MORITZ HONIGMANN.

(By his Agent, P. MAGEMANN.)

Witness—

EDWD. WATERS,
Melbourne, Patent Agent.

This is the specification referred to in the annexed Letters of Registration granted to Moritz Honigmann, the twenty-third day of June, A.D. 1884.

AUGUSTUS LOFTUS.

REPORT.

Sir,

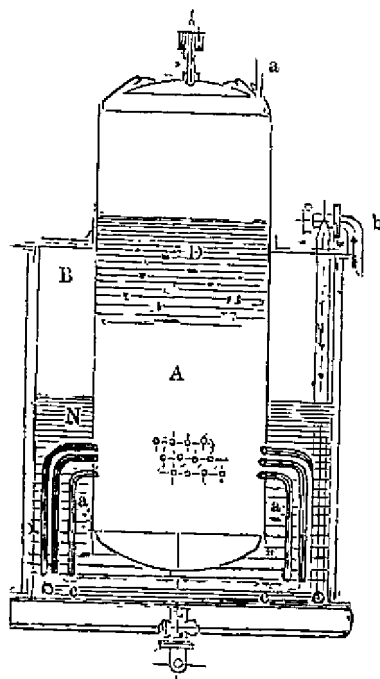
We do ourselves the honor to report, in reply to your blank cover of the 24th instant (No. 4615), transmitting the Petition of Mr. Moritz Honigmann, for the registration of an invention entitled "An Improved Method of Generating Heat, and an Improved Apparatus for carrying such method into effect," that we are of opinion that the prayer of the Petitioner may be granted in terms of the specification, drawing, and claim.

The Under Secretary of Justice.

Sydney, 30 April, 1884.

We have, &c.,

E. C. CRACKNELL,
GOTHER K. MANN.



This is the Drawing referred to in the annexed Letters of Registration granted to Moritz Honigmann, this twenty-third day of June, A. D., 1884.

"AUGUSTUS LOFTUS."



A.D. 1884, 23rd June. No. 1444.

IMPROVEMENTS IN SECONDARY BATTERIES.

LETTERS OF REGISTRATION to Charles Francis Brush, for Improvements in the Process or Method of, and in Apparatus for, "forming" or preparing Plates or Elements for use in Secondary Batteries.

[Registered on the 24th day of June, 1884, in pursuance of the Act 16 Vic. No. 24.]

BY HIS EXCELLENCY THE RIGHT HONORABLE SIR AUGUSTUS WILLIAM FREDERICK SPENCER LOFTUS (commonly called LORD AUGUSTUS LOFTUS), Knight Grand Cross of the Most Honorable Order of the Bath, a Member of Her Majesty's Most Honorable Privy Council, Governor and Commander-in-Chief of the Colony of New South Wales and its Dependencies.

TO ALL TO WHOM THESE PRESENTS SHALL COME, greeting :

WHEREAS CHARLES FRANCIS BRUSH, of Cleveland, Ohio, one of the United States of America, hath by his Petition humbly represented to me that he is the author or designer of a certain invention or improvement in manufactures, that is to say, of an invention entitled "Improvements in the Process or Method of, and in Apparatus for, 'forming' or preparing Plates or Elements for use in Secondary Batteries," which is more particularly described in the specification and the sheet of drawings which are hereunto annexed; and that he, the said Petitioner, hath deposited with the Honorable the Treasurer of the said Colony of New South Wales the sum of Twenty Pounds sterling, for defraying the expense of granting these Letters of Registration, as required by the Act of Council, sixteenth Victoria number twenty-four; and hath humbly prayed that I would be pleased to grant Letters of Registration, whereby the exclusive enjoyment and advantage of the said invention or improvement might be secured to him for a period of fourteen years: And I, being willing to give encouragement to all inventions and improvements in the arts or manufactures which may be for the public good, and having received a report favourable to the prayer of the said Petition, from competent persons appointed by me to examine and consider the matters stated therein and to report thereon for my information, am pleased, with the advice of the Executive Council, and in exercise of the power and authority given to me by the said Act of Council, to grant, and do by these Letters of Registration grant unto the said Charles Francis Brush, his executors, administrators, and assigns, the exclusive enjoyment and advantage of the said invention or improvement, for and during the term of fourteen years from the date hereof; to have, hold, and exercise unto the said Charles Francis Brush, his executors, administrators, and assigns, the exclusive enjoyment and advantage thereof, for and during and unto the full end and term of fourteen years from the date of these presents next and immediately ensuing, and fully to be complete and ended: Provided always, that if the said Charles Francis Brush shall not, within three days after the granting of these Letters of Registration, register the same in the proper office in the Supreme Court, at Sydney, in the said Colony of New South Wales, then these Letters of Registration, and all advantages whatsoever hereby granted, shall cease and become void.

In witness whereof, I have hereunto set my sign manual, and have caused the present Letters of Registration to be sealed with the seal of the said Colony of New South Wales, at Government House, Sydney, in New South Wales, this twenty-third day of June, in the year of our Lord one thousand eight hundred and eighty-four.

[r.s.]

AUGUSTUS LOFTUS.

Improvements in Secondary Batteries.

SPECIFICATION of CHARLES FRANCIS BRUSH, of Cleveland, in the United States of America, for an invention entitled "Improvements in the Process or Method of, and in Apparatus for, 'forming' or preparing Plates or Elements for use in Secondary Batteries."

THE present invention relates to certain improvements in the "forming," as it is technically termed, of electrodes, elements, or plates for use in secondary batteries, and the nature of it consists chiefly and in general terms in a process or method of operation, wherein the lead plate, or other form of battery element, is alternately heated and cooled after and during or in the intervals of an electro-chemical charging action, substantially as hereinafter set forth and claimed.

The use of lead plates, frames, diaphragms, &c., of various shapes and constructions, whereon to "form" a peroxide coating, is already, to a certain extent, known in the art; and various processes have been described and patented relative to such "forming" operations. So much of such "forming" operation as results from the passage of an electric current through the battery from any suitable electric generator, with reference to the production of such peroxide, is commonly known in the art as "charging," and it will be designated by that term herein; and as regards this "charging" operation, any suitable means, apparatus, or process adapted to electro-chemically produce a peroxide surface on the electrode or element may be employed; and such operations are now so well understood in the art that I do not deem it necessary to describe them, or any of them, in detail.

But, in general terms, it may be stated that in such charging operations, two or more lead plates, of any suitable form, immersed in dilute sulphuric acid, and properly associated and coupled, are subjected to the action of the current of an electric generator, in such manner as to produce on the surface of one called the oxygen element, or on more than one if properly coupled, a coating of peroxide of lead. In this operation, water is decomposed, hydrogen is occluded by or combines with one or more of the lead plates, which are hence called hydrogen elements, and the oxygen combines with the lead of the other plate or plates, or oxygen element or elements, to form the peroxide coating. Now, if the exciting current be cut off, it will be found that the apparatus has become a powerful battery, giving a current in a direction opposite to that of the exciting one; but this current is of short duration. Repeated or long continued charging of the apparatus increases somewhat its capacity, but the latter will remain small. It has been found, however, that the capacity of the apparatus may be greatly increased by reversing the charge from time to time, frequently during the first few days, and more rarely afterwards. Also an increase of capacity has been secured by alternately charging and discharging, the peroxide coating being a little thicker or deeper after each discharge and recharge. And still further, the work of charging has been done intermittently, the battery being allowed to lie idle or rest for a time after one charging operation, and before the next. Any of these, or other kindred operations, come within the meaning of what I term "charging" or "re-charging." And, as regards the lead plate or other battery element employed, I prefer the use of plates made of cast lead, with surfaces so ribbed, grooved, or corrugated, as to give a large surface exposed to a peroxidizing action. I have found that cast lead is peculiarly adapted to this purpose, partly at least for the reason that it is more porous or more permeable to the peroxidizing action referred to than when it is compacted by rolling; but sheet, rolled, or wrought lead, may be employed, or lead in granulated or spongy or porous or other suitable form, and the shape or form of the plates or elements may also be varied at pleasure.

In the processes of "forming" secondary battery elements, as above referred to, or in any other processes known to me prior to the date of the present invention, a long time is required, say several months, to so completely "form" the same as to secure economic commercial results. A peroxide coating once secured over the surface of the sheet, itself constitutes a partial barrier or protection as against a deeper oxidation of the lead plate by the charging current, if the latter be continued. If, now, the current be cut off for a time, "local action," somewhat similar to that in ordinary galvanic batteries, and electrical in its nature, commences between the peroxide of lead and the backing or support of metallic lead with which it is in contact. By this local action the peroxide of lead is gradually reduced to a lower state of oxidation and more of the metallic lead back of or beneath it is oxidized by the oxygen thus made available. Then if the current be again turned on, such oxidized coating, deeper or thicker than before, will be brought up to the state or condition of a peroxide, with perhaps some little peroxidizing action on the metallic lead beneath the already oxidized coating. In order to secure good results, these operations, so alternated, must, as heretofore practised, be continued for a long time.

My present invention is chiefly directed to the facilitating or hastening of the "local action" above referred to so as thereby to shorten materially the time required therefor. And this I do by alternately heating and cooling the battery element or plate after each charging operation. This I repeat as often as may be necessary or desirable, and finally I recharge so as to bring the entire oxidized coating up to a peroxide state or condition. And the useful results I secure are, as I now believe, due, in part at least, to the unequal or ununiform expansion and contraction of the metallic lead and the peroxide coating, under the different and varying temperatures employed, whereby the metallic lead along the plane of union of the peroxide therewith is more perfectly or completely opened up or perhaps slightly disintegrated, so as to be more completely and more quickly subjected to the "local action" above referred to. And by thus facilitating, hastening, and deepening the "local action," I correspondingly facilitate, hasten, and deepen the peroxidizing work or effect sought for.

The lead element adopted, being placed in a "forming" cell or battery, and properly associated with a counter-electrode, acid bath, &c., is charged in any suitable way continuously or intermittently a greater or less length of time, or till the electro-chemical action of the charging current shall have produced a considerable coating of peroxide, or such or about such a coating as can be economically produced in that way and under such conditions. Such coating is formed rapidly at first, and more slowly as the work goes on, and hence the point at which it may be best arrested, preliminary to the next step of the process, may be left largely to the discretion of the skilled operator; but preferably as heavy a coating should be made as can be secured advantageously or with due regard to economy. Then the lead element still in the cell, but with the charging current cut off, or suspended or weakened if previously heavy, is heated in any suitable or desired way to a temperature of about 200° or 212° Fah., more or less, though some benefit will follow from an elevation of temperature much less than that thus indicated.

The

Improvements in Secondary Batteries

The battery element or elements thus heated are preferably kept at, or approximately at, the temperature thus indicated for a few hours, say for a period of about six or eight hours, though beneficial results will follow even if the plates be allowed to cool in a less time, or even if allowed to cool down immediately after heating. Care should be taken that they are not kept at a high temperature so long as to produce any material peeling or loosening of the peroxide, or other injurious results; and within this limit the length of such time may be varied at pleasure. Next, the battery element or elements are allowed to cool down, or are by artificial means cooled down, by preference to or nearly to, or even below, atmospheric temperature, and are then again subjected to the action of the charging current.

One such series of operations, that is, heating (after the primary charging), cooling, and recharging, will give a beneficial result, by increasing the thickness of the peroxide coating to a much greater extent than would be possible by a continuation of the primary charging operation during the same length of time; but it will be better to repeat the process one or more times, that is, by again heating, cooling, and recharging, and so on, with these operations following each other in regular orderly succession, until the desired thickness or depth of peroxide coating is obtained.

As already stated, any suitable apparatus or means may be employed in the heating operation above described, and also for cooling; but, in the accompanying drawing, I have shown one which I have found to be suitable for the purpose, and one which I include herein as a part of the present invention.

Referring to the drawing forming part of this specification, fig. 1 is a longitudinal vertical section of an apparatus illustrative of my present invention, fig. 2 is a transverse vertical section thereof, and fig. 3 shows a modification of the heating apparatus.

In the drawing, A represents a box, case, or retort of any desired size or capacity, and provided with a cover or lid A', either removable or secured by hinge *g* and key *g'*. The lower edges of the sides and ends are flared inward as at *a*; and immediately beneath these flanges a pan-shaped bottom B is secured by bolts or by hinges *h* and keys *h'*, and the lead lining *e* of the box has a downward flange *e'* to make a seal or water trap. The box is provided with any suitable seats or supports *b* of insulating material, and the battery cells R, with the lead plates, acid, &c., therein, are arranged side by side on such supports, but out of contact with the sides of the box, and kept from coming in contact with each other by means of interposed racks *d*, also of insulating material; and in order that the charging, heating, and cooling may be done without the necessary removal of the cells R from and back to the box A, I provide for charging by coupling up the positive and negative electrodes by wires or other suitable conductors *e e*, and connect the circuit charging terminal wires *e'* therewith in any suitable way. In order to do the heating as described, I make use of free steam, and admit the same at the proper times directly or indirectly from any suitable steam generator by a suitable pipe entering at any desired point, as at *s*.

In operation, with an apparatus thus constructed, the cells with their plates, &c., properly arranged and coupled and placed on the insulating supports, are charged until peroxidized as may be desired. The charging current is then cut off or stopped, or (as may be done) so far weakened that practically it will be inoperative as regards any rapid peroxidizing action or result, and then steam is turned on through the port *s*. The steam passes freely all round and between the cells R, and at first is condensed somewhat rapidly, so that the water of condensation, accumulating in the pan-shaped bottom B, forms a seal or water trap around the edges of the flange *e'*; and if the bottom pan becomes full, the excess flows out at the joint of the bottom pan B and box A. The steam heats up the cells and their contents to about the temperature specified. As soon as this is done, or after a few hours as above stated, the steam is shut off, the bottom B is removed (if bolted) or dropped down (if hinged), and the lid or cover A' is raised, so that external air may pass freely up, around, and between the cells, and so cool them down rapidly. I consider that rapid cooling is desirable, and hence artificial means of refrigeration of any known or suitable construction may be added. As soon as the cooling is done, the battery element may be again charged; and if further treatment is desired, the box should be reclosed and the battery elements be again heated, cooled, and charged, and so on as often as may be desired.

In this description I have assumed that the cells R are made, as I commonly make them, of lead; and in such case I so couple them with the battery element or elements therein that they shall constitute the counter-electrode hereinbefore referred to. But with other forms or kinds of cells, the arrangement of the elements and the coupling should be suitably changed.

I have described the plates or electrodes or battery elements as remaining in their cells during all the operations described; but while charging must of course be done under such conditions, it is also true that for heating and cooling purposes they may be removed from their cells, placed in a suitable box, retort, or chamber, and heated by steam in the manner set forth. And in this connection steam is especially beneficial, since it has the capacity of keeping the plates moist while being heated or kept in a heated state; but when the plates are thus treated while in the acid of the cells, hot air or other hot fluid or other manner of applying heat may be used. Or, instead of using free steam, the steam or other hot fluid may be passed through a coil or coils of pipe arranged in the box, as at *n*, fig. 2, or even in the cells themselves, as in fig. 3. Such of the plates thus treated or "formed," as are intended to be used as the negative or hydrogen elements of a secondary battery, are of course to be subsequently treated by an electric current in a reverse direction, so as to reduce the oxide to a metallic sponge, as is well understood in the art. In such case, recharging, after the last cooling, may be unnecessary.

Also, without departing from the present invention, other steps or features of secondary battery "formation" may be added or interjected as desired, such as discharging the battery, reversing the current, &c.

While I have described the operations of primary charging, heating, cooling, and recharging as going on or being performed separately and in orderly succession, and while I believe that to be the best manner of working the invention, and for that reason have so described it, the process may in some respects be modified without any material departure from the scope of the invention; as, for example, the recharging current may be allowed to act during all or a portion of the time occupied in heating and cooling, provided such current be so weak, or if previously strong, be so weakened that its peroxidizing effect is inappreciable or even slow as distinguished from rapid; for I have found that a rapid peroxidizing action, during the heating and cooling operations, tends to defeat the object in view: or the recharging operation may lap somewhat on to the cooling, or on to the heating when the latter is prolonged, so that recharging may begin at an earlier stage of the operation, thus economizing time if found desirable.

CLAIMS.

Improvements in Secondary Batteries.

CLAIMS.

- 1st. In the operation of "forming" plates, elements, or electrodes for secondary battery use, and as a preparatory to further treatment by recharging or reversal of the current, the described process of treatment which consists in successively charging, heating, and cooling the same, substantially as set forth.
- 2nd. The process of "forming" plates, elements, or electrodes for secondary battery use by successively charging, heating, and cooling the same and recharging, substantially as set forth.
- 3rd. The method of "forming" plates, elements, or electrodes for secondary battery use, by repeatedly charging, heating, and cooling the same in regular succession, and finally recharging, substantially as set forth.
- 4th. As a step in the process of "forming" plates, electrodes, or elements for secondary battery use, heating and cooling the same after the action of a peroxidizing current, substantially as set forth.
- 5th. As an apparatus for the "forming" of elements for secondary battery use, a box, case, or retort, having in combination means for alternately heating and cooling the elements while contained in their cells, suitable supports of insulating material for receiving the cells, and charging circuit terminals, through which to charge and recharge the elements without the necessary removal thereof from their cells, substantially as set forth.

Witness—

W. S. BAYSTON,
Patent Law Clerk, Melbourne.

C. F. BRUSH,
(By his Agent, EDWD. WATERS).

This is the specification referred to in the annexed Letters of Registration granted to Charles Francis Brush, the twenty-third day of June, A.D. 1884.

AUGUSTUS LOFTUS.

REPORT.

Sir,

We do ourselves the honor to report, in reply to your blank cover of the 19th instant, No. 4360, transmitting the Petition of Mr. Charles Francis Brush for the registration of an invention entitled, "Improvements in the process or method of, and in apparatus for, forming or preparing plates or elements for use in Secondary Batteries," that we are of opinion the prayer of the Petitioner may be granted, in terms of his specification, drawings, and claim.

We have, &c.,
E. C. CRACKNELL.
GOTHEK. MANN.

The Under Secretary of Justice.

[Drawings—one sheet.]

FIG. 1.

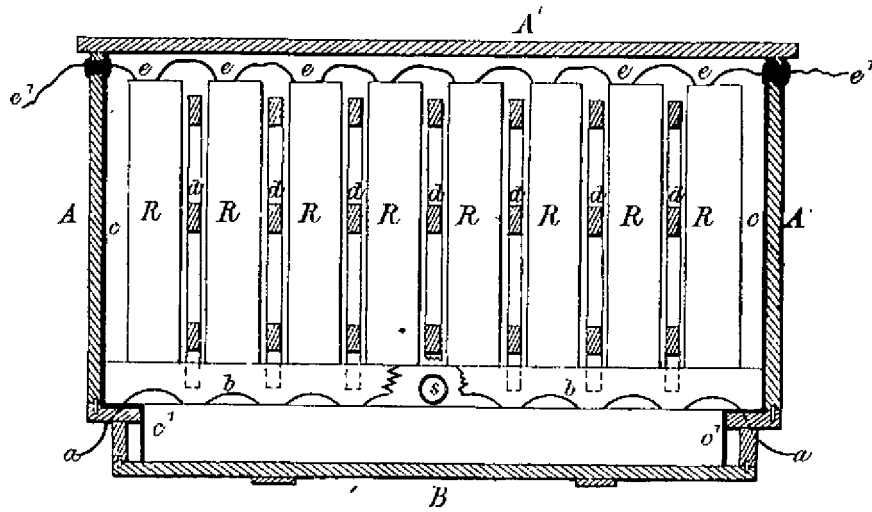


FIG. 2.

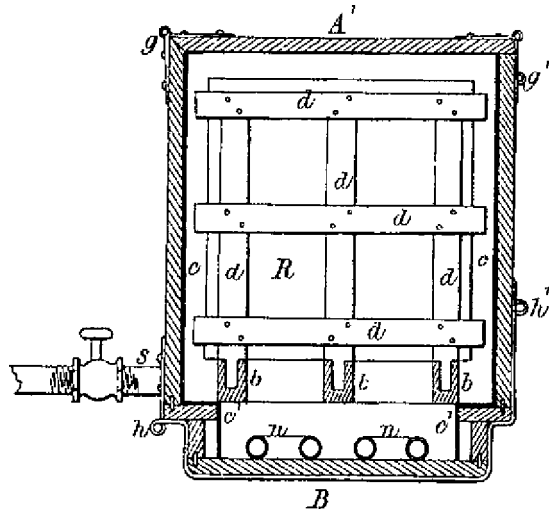
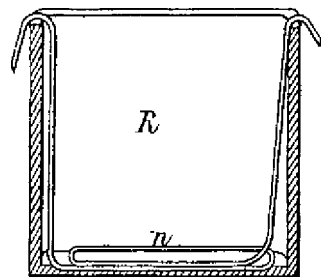


FIG. 3.



*This is the Sheet of Drawings referred to in the annexed
Letters of Registration granted to Charles Francis
Brash, the twenty third day of June, A.D. 1884.*

Augustus Loftus.

(Sig 245-)



A.D. 1884, 23rd June. No. 1445.

IMPROVEMENTS IN MACHINERY FOR TYING KNOTS.

LETTERS OF REGISTRATION to Joshua Alexander Kay, Nathaniel Buchanan, and Alexander Robert Wallis, for Improvements in Machinery for Tying Knots.

[Registered on the 24th day of June, 1884, in pursuance of the Act 16 Vic. No. 24.]

BY HIS EXCELLENCY THE RIGHT HONORABLE SIR AUGUSTUS WILLIAM FREDERICK SPENCER LOFTUS (commonly called LORD AUGUSTUS LOFTUS), Knight Grand Cross of the Most Honorable Order of the Bath, a Member of Her Majesty's Most Honorable Privy Council, Governor and Commander-in-Chief of the Colony of New South Wales and its Dependencies.

TO ALL TO WHOM THESE PRESENTS SHALL COME, greeting :

WHEREAS JOSHUA ALEXANDER KAY, NATHANIEL BUCHANAN, and ALEXANDER ROBERT WALLIS, of Melbourne, in the Colony of Victoria, have by their Petition humbly represented to me that they are the authors or designers of a certain invention or improvement in manufactures, that is to say, of an invention entitled "Improvements in Machinery for Tying Knots," which is more particularly described in the specification and the sheet of drawings which are hereunto annexed ; and that they, the said Petitioners, have deposited with the Honorable the Treasurer of the said Colony of New South Wales the sum of Twenty Pounds sterling, for defraying the expense of granting these Letters of Registration, as required by the Act of Council, sixteen Victoria, number twenty-four ; and have humbly prayed that I would be pleased to grant Letters of Registration, whereby the exclusive enjoyment and advantage of the said invention or improvement might be secured to them for a period of fourteen years : And I, being willing to give encouragement to all inventions and improvements in the arts or manufactures which may be for the public good, and having received a report favourable to the prayer of the said Petition, from competent persons appointed by me to examine and consider the matters stated therein and to report thereon for my information, am pleased, with the advice of the Executive Council, and in exercise of the power and authority given to me by the said Act of Council, to grant, and do by these Letters of Registration grant unto the said Joshua Alexander Kay, Nathaniel Buchanan, and Alexander Robert Wallis, their executors, administrators, and assigns, the exclusive enjoyment and advantage of the said invention or improvement, for and during the term of fourteen years from the date hereof ; to have, hold, and exercise unto the said Joshua Alexander Kay, Nathaniel Buchanan, and Alexander Robert Wallis, their executors, administrators, and assigns, the exclusive enjoyment and advantage thereof, for and during and unto the full end and term of fourteen years from the date of these presents next and immediately ensuing, and fully to be complete and ended : Provided always, that if the said Joshua Alexander Kay, Nathaniel Buchanan, and Alexander Robert Wallis shall not, within three days after the granting of these Letters of Registration, register the same in the proper office in the Supreme Court, at Sydney, in the said Colony of New South Wales, then these Letters of Registration, and all advantages whatsoever hereby granted, shall cease and become void.

In witness whereof, I have hereunto set my sign manual, and have caused the present Letters of Registration to be sealed with the seal of the said Colony of New South Wales, at Government House, Sydney, in New South Wales, this twenty-third day of June, in the year of our Lord one thousand eight hundred and eighty-four.

[L.S.]

AUGUSTUS LOFTUS.

Improvements in Machinery for Tying Knots.

SPECIFICATION of an invention intituled "Improvements in Machinery for Tying Knots."

TO ALL WHOM IT MAY CONCERN: Be it known that we, JOSHUA ALEXANDER KAY, NATHANIEL BUCHANAN, mechanical engineers, and ALEXANDER ROBERT WALLIS, machinery merchant, all of Melbourne, in the Colony of Victoria, Australia, have invented certain improvements in machinery for tying knots, of which the following is a specification:—

This invention relates to machinery for tying knots, the novelty of which consists in our knotting apparatus being constructed in one single piece. The ordinary knotting hook, which is composed of three pieces, namely, knotting hook, movable jaw, and friction roller, is replaced by our single-action knotting hook, which consists of an outer and inner jaw, which are tapered and slightly curved to a point, and cast or formed in one piece. The point of outer jaw is bent in form of a hook, by preference projecting inward in a slanting position, as shown in accompanying drawings. Figure 1 represents front elevation of our knotting hook; figure 1^b, top view of the same. Figure 2 shows side elevation of our knotting hook; figure 2^b, top view of the same. Figure 3, back elevation of our knotting hook; figure 3^b, top view of the same. Figure 4, back elevation, with shank or spindle displaced about $\frac{3}{8}$ of an inch off the centre of the hook, to give the hook an eccentric motion, with the view of allowing the hook to revolve close against the knife to ensure short ends; figure 4^b, top view of the same. A is the shank or spindle; B is the inner jaw; C is the outer jaw; C' is the retaining hook.

The mode of operation is as follows:—When the twine is twisted round the hook in the ordinary manner, the jaws being apart allows the ends which are to be cut off to slip in between the jaws B and C, and is pushed into position by the action of the string guide, where it is caught by the retaining hook C', in which position the loop is pulled off the jaws by the knife arm; immediately following this movement the twine is cut, the ends being retained by the hook C', are drawn through the loop, thus forming and completing a perfect knot.

The advantages of our invention over the existing hook are—

First—Its simplicity, being comprised in one piece, obviating the necessity of a jointed jaw, friction roller, eccentric-faced bearing, strong-pressure spring, and cam.

Second—The knot is tied previous to the twine being cut.

Third—The ends of twine are always pulled through the knot, thus securing against the probability of becoming loose or untied.

Fourth—Its non-liability to get out of order, being positive in its action.

For existing binding machines the shank or spindle of our knotting hook would require to be about $\frac{3}{8}$ of an inch off the centre of hook, as shown in figure 4; but when for machines with wider space in knife arm, and otherwise simplified as already stated, the shank or spindle or knotting hook may be in a straight line with centre of knotting hook, as shown in figure 3.

The retaining hook C' may be either on the outer or inner jaw, but we prefer to place it in connection with the outer jaw.

Having thus described the nature of our invention, and the manner in which the same is to be performed, we would have it understood that what we claim as new, and therefore desire to secure by Letters Patent, is—

First—A knotting hook with double jaw, made or formed in one piece, substantially as described and shown in accompanying drawings.

Second—A double-jaw knotting apparatus with retaining hook on either the outer or inner jaw, substantially as described and shown in accompanying drawings.

Third—A double-jaw knotting hook in one piece, with shank or spindle either in a line with centre of hook or placed a given distance off the centre, to give the hook an eccentric motion, substantially as described and shown in accompanying drawings.

JOSHUA ALEXANDER KAY.
N. BUCHANAN.
A. R. WALLIS.

Witnesses to signatures—
JOHN H. WINTON,
H. F. HAYES.

This is the specification referred to in the annexed Letters of Registration granted to Joshua Alexander Kay, Nathaniel Buchanan, and Alexander Robert Wallis, the twenty-third day of June, A.D. 1884.

AUGUSTUS LOFTUS.

REPORT.

Sir,

We do ourselves the honor to report, in reply to your blank cover of the 18th instant, No. 4384, transmitting the petition of Joshua Alexander Kay, Nathaniel Buchanan, and Alexander Robert Wallis, for the registration of an invention entitled "Improvements in Machinery for Tying Knots," that we are of opinion the prayer of the petitioners may be granted, in terms of their specification, drawings, and claim.

We have, &c.,

E. C. CRACKNELL.
GOTHER K. MANN.

The Under Secretary of Justice.

Fig. 1^o

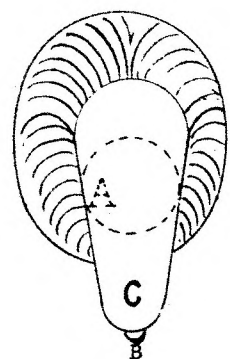


Fig. 2^o

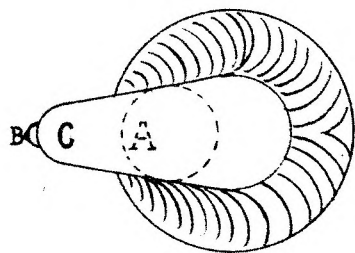


Fig. 3^o

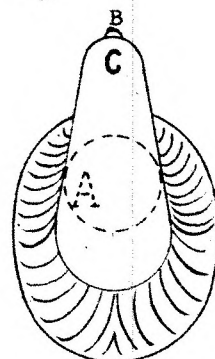


Fig. 4^o

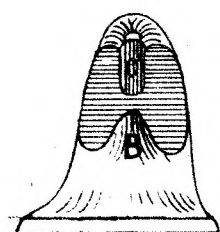
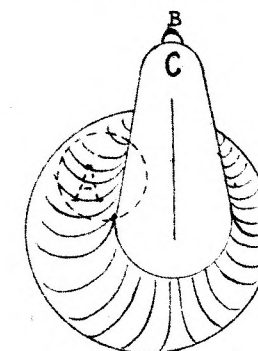


Fig. 1.

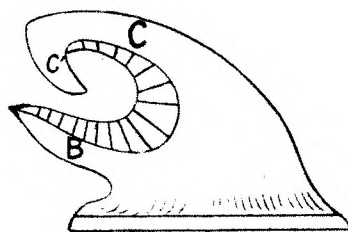


Fig. 2.

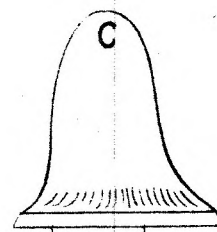


Fig. 3.

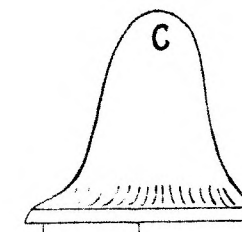


Fig. 4.

Witness to Signatures
John A. Windsor
H. F. Harris

Joshua Alexander May
J. Buchanan
A. R. Wallis.

(Sig 245-)

This is the Sheet of Drawings referred to in the annexed Letters of Registration granted to Joshua Alexander May, Nathaniel Buchanan, & Alexander Robert Wallis, the twenty third day of June, A.D. 1884.
Augustus Loftus.



A.D. 1884, 23rd June. No. 1446.

IMPROVEMENTS IN EXTRACTING NICKEL FROM ITS ORES.

LETTERS OF REGISTRATION to John Clark for Improvements in extracting Nickel from its Ores.

[Registered on the 24th day of June, 1884, in pursuance of the Act 16 Vic. No. 24.]

BY HIS EXCELLENCY THE RIGHT HONORABLE SIR AUGUSTUS WILLIAM FREDERICK SPENCER LOFTUS, (commonly called LORD AUGUSTUS LOFTUS), Knight Grand Cross of the Most Honorable Order of the Bath, a Member of Her Majesty's Most Honorable Privy Council, Governor and Commander-in-Chief of the Colony of New South Wales and its Dependencies.

TO ALL TO WHOM THESE PRESENTS SHALL COME, greeting :

WHEREAS JOHN CLARK, of Glasgow, in the county of Lanark, Scotland, hath by his Petition humbly represented to me that he is the author or designer of a certain invention or improvement in manufactures, that is to say, of an invention entitled "Improvements in extracting Nickel from its Ores," which is more particularly described in the amended specification which is hereunto annexed ; and that he, the said Petitioner, hath deposited with the Honorable the Treasurer of the said Colony of New South Wales the sum of Twenty Pounds sterling, for defraying the expense of granting these Letters of Registration, as required by the Act of Council, sixteenth Victoria, number twenty-four ; and hath humbly prayed that I would be pleased to grant Letters of Registration, whereby the exclusive enjoyment and advantage of the said invention or improvement might be secured to him for a period of fourteen years : And I, being willing to give encouragement to all inventions and improvements in the arts or manufactures which may be for the public good, and having received a report favourable to the prayer of the said Petition, from competent persons appointed by me to examine and consider the matters stated therein and to report thereon for my information, am pleased, with the advice of the Executive Council, and in exercise of the power and authority given to me by the said Act of Council, to grant, and do by these Letters of Registration grant unto the said John Clark, his executors, administrators, and assigns, the exclusive enjoyment and advantage of the said invention or improvement, for and during the term of fourteen years from the date hereof ; to have, hold, and exercise unto the said John Clark, his executors, administrators, and assigns, the exclusive enjoyment and advantage thereof, for and during and unto the full end and term of fourteen years from the date of these presents next and immediately ensuing, and fully to be complete and ended : Provided always, that if the said John Clark shall not, within three days after the granting of these Letters of Registration, register the same in the proper office in the Supreme Court, at Sydney, in the said Colony of New South Wales, then these Letters of Registration, and all advantages whatsoever hereby granted, shall cease and become void.

In witness whereof, I have hereunto set my sign manual, and have caused the present Letters of Registration to be sealed with the seal of the said Colony of New South Wales, at Government House, Sydney, in New South Wales, this twenty-third day of June, in the year of our Lord one thousand eight hundred and eighty-four.

[L.S.]

AUGUSTUS LOFTUS.

Improvements in extracting Nickel from its Ores.

TO ALL TO WHOM THESE PRESENTS SHALL COME: I, JOHN CLARK, of Glasgow, in the county of Lanark, Scotland, send greeting:

WHEREAS I am desirous of obtaining Letters of Registration for the Colony of New South Wales, securing unto me Her Majesty's special license that I, my executors, administrators, and assigns, and such others as I or they should at any time agree with, and no others, should and lawfully might from time to time, and at all times, during the term of fourteen years next and immediately after the date of the said Letters of Registration, make, use, exercise, and vend within the said Colony of New South Wales an invention for "Improvements in extracting Nickel from its Ores." And whereas, in order to obtain such Letters of Registration, I must, by an instrument or specification in writing under my hand and seal, particularly describe and ascertain the nature of the said invention and in what manner the same is to be performed: Now know ye, that the nature of the said invention, and the manner in which the same is to be performed, is particularly described and ascertained in and by the following statement in writing, that is to say—

My said invention has for its object the extraction of nickel from its ores by new and improved processes, which are advantageously applicable to ores of the nature of those found in New Caledonia, and which consist principally of oxides of nickel, magnesia, and silica.

In carrying out the invention the nickel ore, either raw or calcined, is reduced to a fine state of division, and is heated in a suitable vessel with hydrochloric acid. For this purpose two and a half parts by weight of strong hydrochloric acid for each part of the ore will usually be sufficient, and will form a solution containing chlorides of nickel, magnesium, iron, and aluminium. The solution is drawn off and boiled with a fresh quantity of the ore so as to utilise any remaining free acid; or, the solution may be at once neutralised, preferably whilst cold, with carbonate of lime or dolomite, which also precipitates any iron and alumina in the solution.

The neutral liquor is separated from the precipitates and transferred into a large wrought-iron or steel boiler, which is by preference fitted with rotating or other agitators. In this boiler there is mixed with the liquor a suitable quantity of finely-divided carbonate of lime, dolomite, or carbonate of magnesia, and the mixture is boiled under a pressure of 90 lb. per square inch, or other sufficient pressure. By means of the pressure and heat thus applied a carbonate of nickel is formed and precipitated whilst chloride of calcium or of magnesium enters into solution, the reaction being one which does not take place under ordinary conditions. The contents of the boiler are next transferred to settling tanks, and after settling the liquor is run off and the precipitated carbonate of nickel is washed and pressed. The carbonate of nickel thus obtained may be converted into oxide of nickel by calcination, or treated according to any suitable known process for the production of metallic nickel or its salts.

When magnesia is used the resulting solution containing chloride of magnesium is evaporated, the application of moderate heat being continued after dryness is attained so as to obtain hydrochloric acid and magnesia, to be used over again.

Instead of boiling the neutral liquor under pressure with carbonate of lime or dolomite, or carbonate of magnesia, the nickel may be precipitated as oxide by boiling with caustic lime or caustic magnesia, or a mixture of both, either in an open vessel or under pressure, the precipitated oxide being afterwards separated from the solution and washed and pressed.

Instead of heating the nickel ore with hydrochloric acid, as hereinbefore described, the ore may be placed on the bed of a reverberatory furnace similar to what is used for making salt cake, but with a deeper bed, and the necessary quantity of hydrochloric acid may be gradually added to it. Heat is applied so as to evaporate the solution to dryness, or nearly so, and the residue is gently heated for a short time. The dry product is removed from the furnace and boiled with water, when the nickel is obtained in solution as chloride, whilst the iron and alumina are for the most part insoluble, being rendered so by the magnesia due to the decomposition of the chloride of magnesium in the furnace. Any iron and alumina remaining in solution are precipitated with carbonate of lime or dolomite, and the nickel in the neutral liquor may afterwards be separated in the manner hereinbefore described.

Sulphuric acid may be substituted for hydrochloric acid in the processes hereinbefore described, and the neutral solution obtained as hereinbefore described will contain sulphate of nickel instead of chloride. The sulphate of nickel may be converted to carbonate by boiling with carbonate of lime or dolomite under a suitable pressure; or, the sulphate of nickel may be converted to oxide of nickel by treatment with caustic lime or burned dolomite.

Having thus particularly described my said invention, and the manner of performing the same, I declare that what I claim is—

First—The production of a carbonate of nickel by boiling the chloride under pressure with carbonate of lime or dolomite, or carbonate of magnesia.

And secondly—The production of a carbonate of nickel by boiling the sulphate under pressure with carbonate of lime or dolomite, or carbonate of magnesia.

In witness whereof, I, the said John Clark, have hereunto set my hand and seal, this twenty-first day of February, in the year of our Lord one thousand eight hundred and eighty-four.

JOHN CLARK.

Signed and sealed in the presence of—

EDMUND HUNT, Witness.

DAVID FERGUSON, Witness.

This is the amended specification referred to in the annexed Letters of Registration granted to John Clark, the twenty-third day of June, A.D. 1884.

AUGUSTUS LOFTUS.

Improvements in extracting Nickel from its Ores.

REPORT.

Sir,

In the matter of the application of Mr. John Clark for Letters of Registration for "Improvements in extracting Nickel from its Ores," we have examined the specification accompanying the same, and have now the honor to report as follows:—Of the five claims made in the specification we find that only Nos. 2 and 3 have sufficient originality to warrant protection. The other three are for well-known processes. We therefore recommend that claims 1, 4, and 5 be expunged, and Letters of Registration granted for Nos. 2 and 3.

The Under Secretary of Justice.

Sydney, 19 April, 1884.

We have, &c.,

J. SMITH.

A. LEIBIUS.

MEMO.—We consider that Letters of Registration may now be issued on the amended specification.

The Under Secretary of Justice.

10 May, 1884.

J. SMITH.

A. LEIBIUS.



A.D. 1884, 23rd June. No. 1447.

IMPROVEMENTS IN THE CONSTRUCTION OF SHEEP AND CATTLE TRUCKS.

LETTERS OF REGISTRATION to Frank Mack, for Improvements in the construction of Sheep and Cattle Trucks.

[Registered on the 24th day of June, 1884, in pursuance of the Act 16 Vic. No 24.]

BY HIS EXCELLENCY THE RIGHT HONORABLE SIR AUGUSTUS WILLIAM FREDERICK SPENCER LOFTUS (commonly called LORD AUGUSTUS LOFTUS), Knight Grand Cross of the Most Honorable Order of the Bath, a Member of Her Majesty's Most Honorable Privy Council, Governor and Commander-in-Chief of the Colony of New South Wales and its Dependencies.

TO ALL TO WHOM THESE PRESENTS SHALL COME, greeting :

WHEREAS FRANK MACK, of Murgha, near Deniliquin, in the Colony of New South Wales, gentleman, hath by his Petition humbly represented to me that he is the author or designer of a certain invention or improvement in manufactures, that is to say, of an invention entitled "Improvements in the construction of Sheep and Cattle Trucks," which is more particularly described in the specification and the sheet of drawings which are hereunto annexed; and that he, the said Petitioner, hath deposited with the Honorable the Treasurer of the said Colony of New South Wales the sum of Twenty Pounds sterling, for defraying the expense of granting these Letters of Registration, as required by the Act of Council, sixteenth Victoria, number twenty-four, and hath humbly prayed that I would be pleased to grant Letters of Registration, whereby the exclusive enjoyment and advantage of the said invention or improvement might be secured to him for a period of fourteen years. And I, being willing to give encouragement to all inventions and improvements in the arts or manufactures which may be for the public good, and having received a report favourable to the prayer of the said Petition, from competent persons appointed by me to examine and consider the matters stated therein, and to report thereon for my information, am pleased, with the advice of the Executive Council, and in exercise of the power and authority given to me by the said Act of Council, to grant, and do by these letters of Registration grant unto the said Frank Mack, his executors, administrators, and assigns, the exclusive enjoyment and advantage of the said invention or improvement, for and during the term of fourteen years from the date hereof; to have, hold, and exercise unto the said Frank Mack, his executors, administrators, and assigns, the exclusive enjoyment and advantage thereof, for and during and unto the full end and term of fourteen years from the date of these presents next and immediately ensuing, and fully to be complete and ended: Provided always, that if the said Frank Mack shall not, within three days after the granting of these Letters of Registration, register the same in the proper office in the Supreme Court, at Sydney, in the said Colony of New South Wales, then these Letters of Registration, and all advantages whatsoever hereby granted, shall cease and become void.

In witness whereof, I have hereunto set my sign manual, and have caused the present Letters of Registration to be sealed with the seal of the said Colony of New South Wales, at Government House, Sydney, in New South Wales, this twenty-third day of June, in the year of our Lord one thousand eight hundred and eighty-four.

[L.S.]

AUGUSTUS LOFTUS.

Improvements in the construction of Sheep and Cattle Trucks.

SPECIFICATION of FRANK MACK, of Murgba, near Deniliquin, in the Colony of New South Wales, gentleman, for an invention entitled "Improvements in the construction of Sheep and Cattle Trucks."

THIS invention has been designed for the purpose of enabling a whole train of trucks to be emptied and filled with sheep or cattle in a continuous stream, instead of emptying and filling each truck separately. This I accomplish by supplying each truck with removable longitudinal partitions or barriers, which can be fitted into position so as to form a passage or race along which the sheep or cattle can travel to the end truck, and with a door at the end of each truck sufficiently large for the passage of the animals, and with a removable platform to connect each truck with its neighbour, such platform having sides, so as to make it a sort of gangway. As each truck is filled these doors are closed, and the gangways and partitions removed when required. For sheep these trucks are made with an upper and a lower floor, and with removable partitions, doors, and gangways for each.

In order, however, that my invention may be clearly understood, I will now refer to the drawings hereto attached, in which fig. 1 represents a side elevation of the whole of one and part of another sheep truck connected together by my removable gangway. Fig. 2 shows end view of a sheep truck with the gangways slid below the floor, and having the lower door closed and the upper door open, and with part of the lower end broken away to show one form of sliding barrier. Fig. 3 is a plan underneath the lower floor of the truck to show the sliding platform, and the contrivances for sliding it. Figs. 4 and 5 represent the removable partitions, of which figs. 6 and 7 are details. Figs. 8, 9, and 10 represent three different methods of constructing these removable partitions or barriers.

From these drawings it will be seen that there are various details of construction whereby my invention may be carried into effect, as I have shown three methods of constructing the removable partitions; and although I have shown only one method of constructing and arranging the doors and the gangways, it is evident that other methods could readily be devised.

Referring first to the gangways—these consist of a floor and sides, the latter being hinged to the former, and the whole being slid along underneath the end of the truck, and slid out again by the handle B attached to lever D, pivoted at F. The floor rests on a projecting ledge N on the next truck, and the sides are kept upright by catches A (see fig. 2). Guides P are for supporting the gangways. Q and Q' are notches for catching the lever D, and so preventing the gangway from sliding from its position.

The doors may be made of any material, and either sliding or hinged. I prefer them of wood and iron, and sliding as shown in fig. 2, where the closed one is marked B².

The removable partitions or barriers may be of any approved material, although I prefer them made like the side of a cattle truck—that is, with a wooden frame and iron rods; and of the three methods of moving them shown, I prefer that marked barrier No. 2 in fig. 9. In fig. 2 the partition or barrier is marked C. It is suspended by hooks and friction rollers H (see figs. 4, 5, 6, and 7) on rods C', and is removed by being slid along such rods. In fig. 9 the removable partition or barrier is hinged at the top and is swung out of or lowered into position by means of chains K and pulleys J. In fig. 10 the removable partition or barrier L is hinged at the ends like folding gates, so as to be opened and closed by the handle O jointed at N to the rods M. In figs. 1 and 4 G shows the catches or bolts for keeping the removable partitions or barriers in position. In the drawings I have represented a sheep truck only, but I adopt precisely the same arrangement and method of construction for cattle trucks, except that there is only one floor instead of two, the doors open the whole height of the truck, the sides of the gangway are made higher, and the removable partitions or barriers are made to fit.

The mode of using my sheep and cattle trucks is as follows:—In commencing to fill a train, all the trucks, except the furthest from the entering end, have the removable partitions or barriers placed in position so as to form a race, the doors are all opened, and the gangways between the trucks lowered and connected; the animals then enter truck No. 1 and pass from it to the next, and so on all along the train until the last truck is filled; then communication with it is cut off by closing its door; the exit door also of the next truck to it is closed, the gangway slid underneath the floor as in fig. 3, and its removable partitions or barriers removed. This truck is then filled, and so on all along the train until all the trucks are filled. In unloading the train the trucks can be reconnected by opening the doors and sliding the gangways into position, and the animals will then disembark in two continuous streams—one from the upper floor, and one from the lower floor.

Having thus described the nature of my invention, and the manner of performing same, I would have it understood that what I believe to be new, and therefore claim, is—

The construction of sheep and cattle trucks with these three peculiarities—first, a removable longitudinal partition or barrier; second, doors at each end; and third, a gangway between each truck and its neighbour, substantially as herein described and explained.

In witness whereof, I, the said Frank Mack, have hereto set my hand and seal, this twenty-second day of April, one thousand eight hundred and eighty-four.

Witness—

EDWD. WATERS, Melbourne, Patent Agent.

FRANK MACK,

(By his Attorney, THOMAS H. BRAIN, junr.)

This is the specification referred to in the annexed Letters of Registration granted to Frank Mack, the twenty-third day of June, A.D. 1884.

AUGUSTUS LOFTUS.

REPORT.

Improvements in the construction of Sheep and Cattle Trucks.

REPORT.

Sir, Sydney, 5 May, 1884.
The application of Mr. Frank Mack for Letters of Registration for "Improvements in the construction of Sheep and Cattle Trucks," having been referred to us, we have examined the plans and specification accompanying the same, and have now the honor to report that we see no objection to the issue of Letters of Registration as prayed for.

The Under Secretary of Justice.

We have, &c.,
JAMES BARNET.
EDMUND FOSBERY.

[Drawings—one sheet.]

No. 1448.

[Assignment of No. 1065. See Letters of Registration for 1882, page 153.]

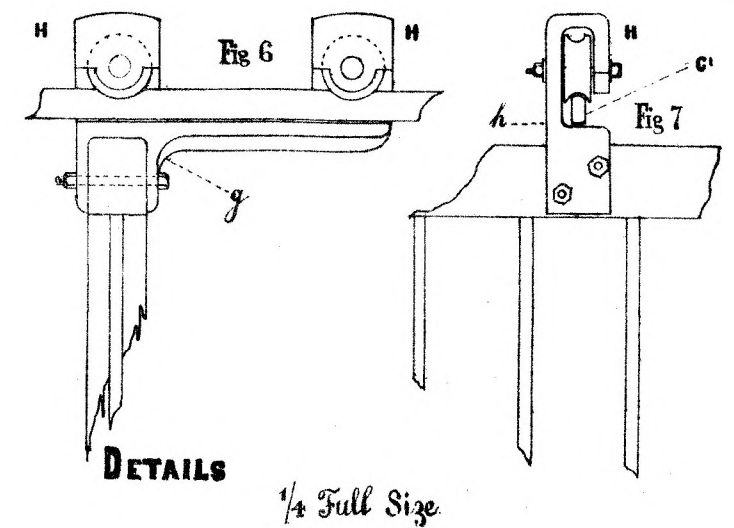
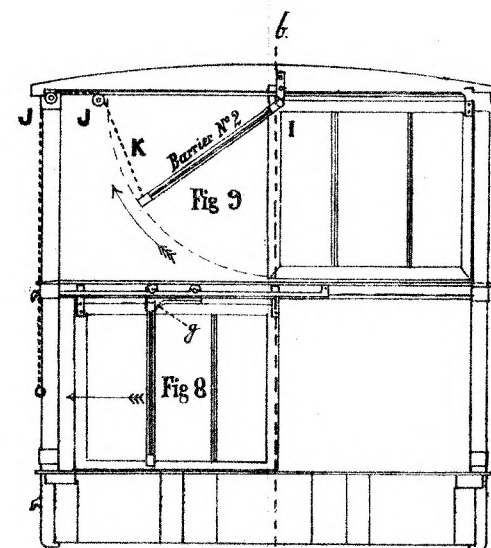
THE "MURCHA" PATENT SHEEP & CATTLE TRUCK

FOR FACILITATING THE TRUCKING OF

Sheep and Cattle

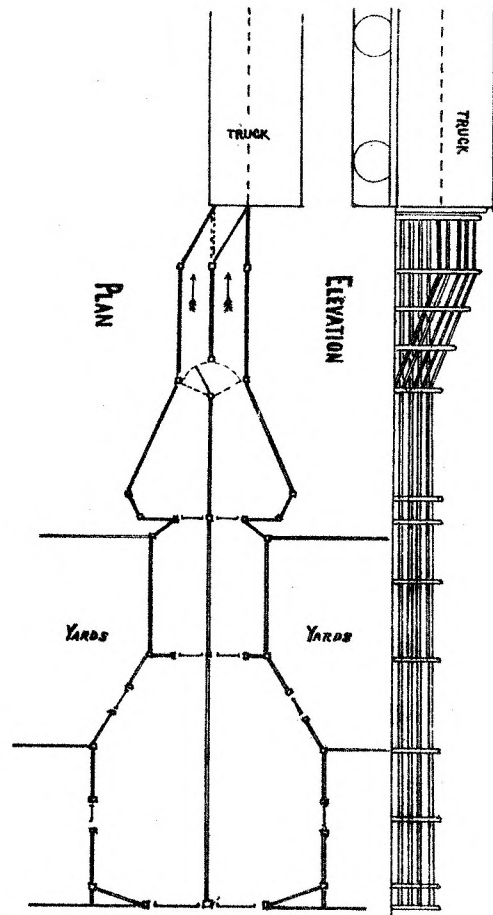
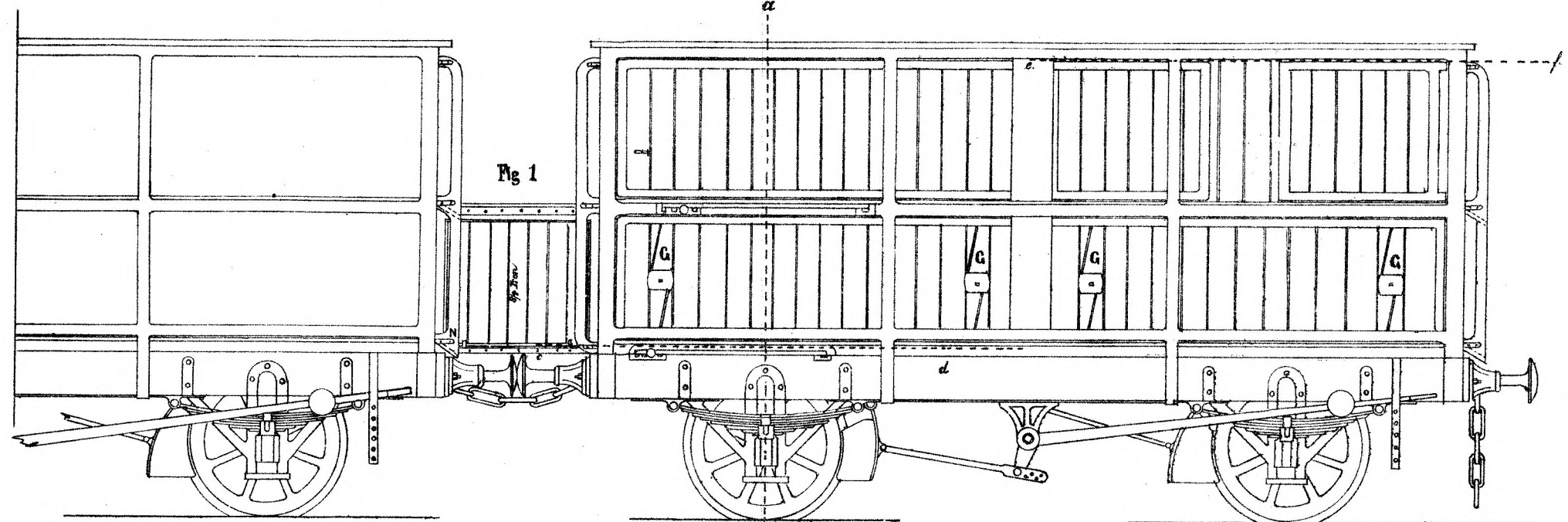
Scale 1/2 Inch to One Foot

BRUFORD & BRAIM
Engineers
67 Chancery Lane
MELBOURNE

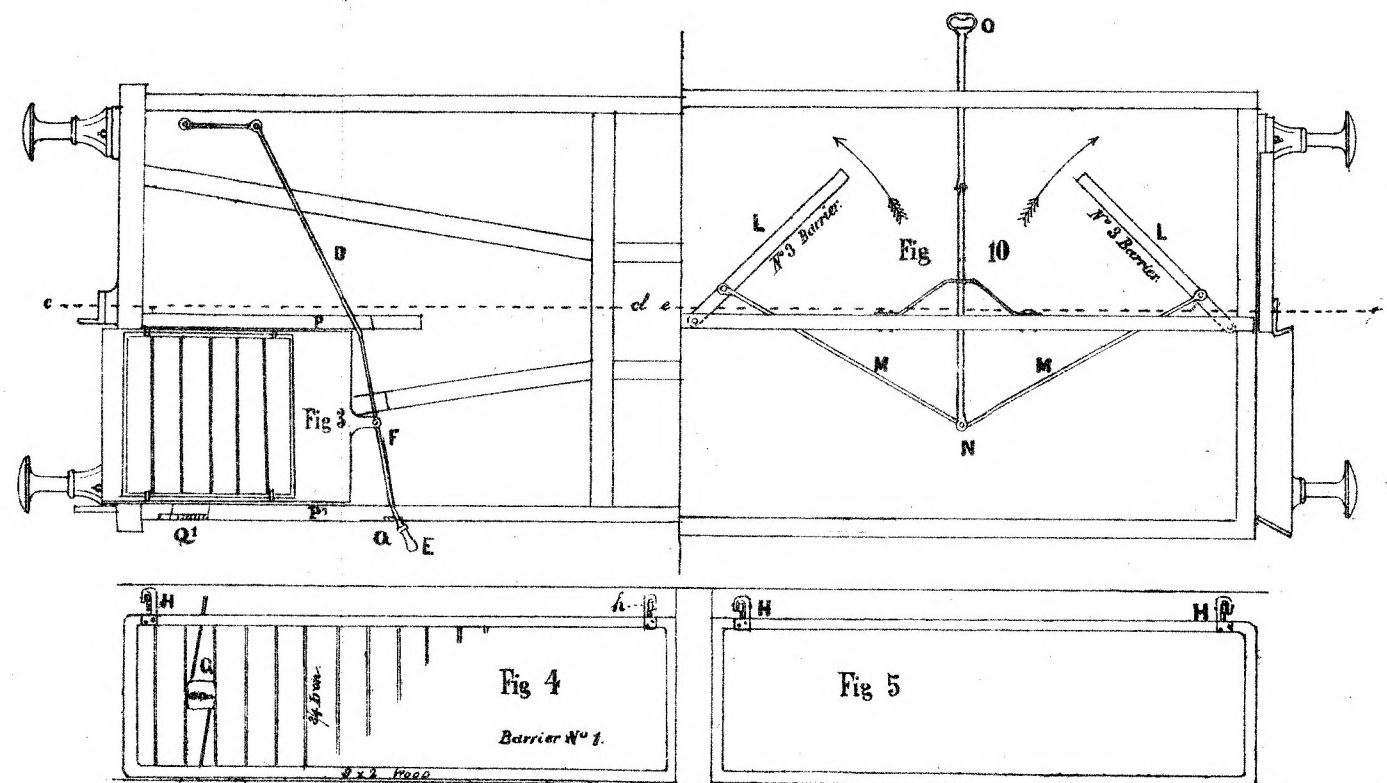
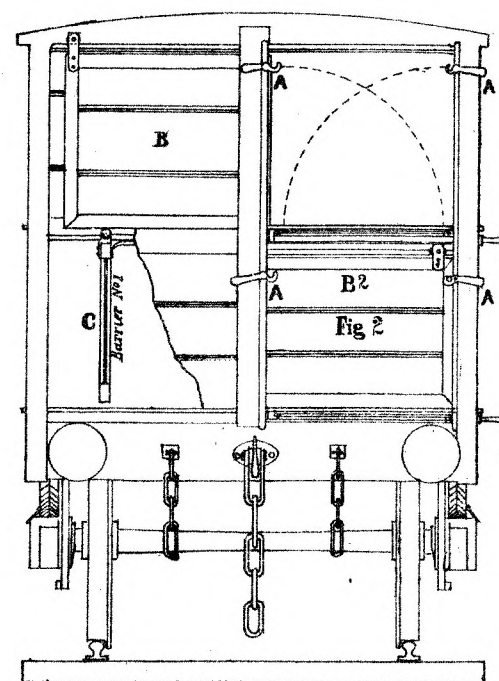


DETAILS

1/4 Full Size



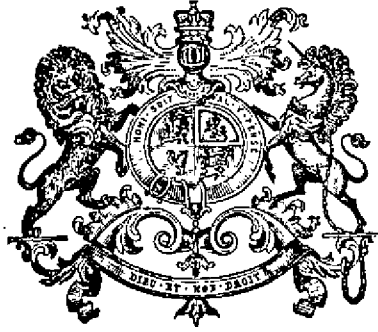
PLAN OF YARDS



This is the Sheet of Drawings referred to in the annexed Letters of Registration granted to Frank Mack, the twenty third day of June, A.D. 1884.
Augustus Loftus.

PHOTO-LITHOGRAPHED AT THE GOVT. PRINTING OFFICE, SYDNEY, NEW SOUTH WALES.

(Sig 245-)



A.D. 1884, 7th July. No. 1449.

PNEUMATIC VENTILATOR.

LETTERS OF REGISTRATION to Robert Newton Helme, for an invention entitled "Pneumatic Ventilator."

[Registered on the 8th day of July, 1884, in pursuance of the Act 16 Vic. No. 24.]

BY HIS EXCELLENCY THE RIGHT HONORABLE SIR AUGUSTUS WILLIAM FREDERICK SPENCER LOFTUS (commonly called LORD AUGUSTUS LOFTUS), Knight Grand Cross of the Most Honorable Order of the Bath, a Member of Her Majesty's Most Honorable Privy Council, Governor and Commander-in-Chief of the Colony of New South Wales and its Dependencies.

TO ALL TO WHOM THESE PRESENTS SHALL COME, greeting :

WHEREAS ROBERT NEWTON HELME, of Sydney, in the Colony of New South Wales, hath by his Petition humbly represented to me that he is the author or designer of a certain invention or improvement in manufactures, that is to say, of an invention entitled "Pneumatic Ventilator," which is more particularly described in the specification and the sheet of drawings which are hereunto annexed ; and that he, the said Petitioner, hath deposited with the Honorable the Treasurer of the said Colony of New South Wales the sum of Twenty Pounds sterling, for defraying the expense of granting these Letters of Registration, as required by the Act of Council, sixteenth Victoria, number twenty-four ; and hath humbly prayed that I would be pleased to grant Letters of Registration, whereby the exclusive enjoyment and advantage of the said invention or improvement might be secured to him for a period of fourteen years : And I, being willing to give encouragement to all inventions and improvements in the arts or manufactures which may be for the public good, and having received a report favourable to the prayer of the said Petition, from competent persons appointed by me to examine and consider the matters stated therein and to report thereon for my information, am pleased, with the advice of the Executive Council, and in exercise of the power and authority given to me by the said Act of Council, to grant, and do by these Letters of Registration grant unto the said Robert Newton Helme, his executors, administrators, and assigns, the exclusive enjoyment and advantage of the said invention or improvement, for and during the term of fourteen years from the date hereof ; to have, hold, and exercise unto the said Robert Newton Helme, his executors, administrators, and assigns, the exclusive enjoyment and advantage thereof, for and during and unto the full end and term of fourteen years from the date of these presents next and immediately ensuing, and fully to be complete and ended : Provided always, that if the said Robert Newton Helme shall not, within three days after the granting of these Letters of Registration, register the same in the proper office in the Supreme Court, at Sydney, in the said Colony of New South Wales, then these Letters of Registration, and all advantages whatsoever hereby granted, shall cease and become void.

In witness whereof, I have hereunto set my sign manual, and have caused the present Letters of Registration to be sealed with the seal of the said Colony of New South Wales, at Government House, Sydney, in New South Wales, this seventh day of July, in the year of our Lord one thousand eight hundred and eighty-four.

[L.S.]

AUGUSTUS LOFTUS.

Pneumatic Ventilator.

SPECIFICATION OF PNEUMATIC VENTILATOR.

FIGURES 1, 2, and 3 are respectively plan, section, and elevation of one form of my new and improved ventilator, in which *a* represents the upcast shaft (which may be cylindrical, rectangular, or otherwise); *b* the first or inner rim of deflectors, arranged with openings between each; *c* the second or middle rim of deflectors, placed opposite the opening in the inner rim; and *d* the third or outer rim of deflectors, placed opposite the openings in the middle rim. By preference these rims are concentric, but they may likewise take a variety of forms, as shown in figure 4, the combinations and effects being substantially the same. *a'*, *b'*, *c'*, show the same arrangement treated hemispherically, to form the upper part or crown; it will have a plain or other suitable bottom, with opening in same fixed over the upcast shaft.

The lower part may be treated as a perfect ventilator in itself, and instead of the hemispherical arrangement of deflectors for a crown, may have a plain flat top, surmounted by a conical or other suitable crown (as shown in figure 5). A modification of the hemispherical arrangement may be used without the lower or cylindrical arrangement of deflectors, and form a perfect ventilator in itself (as shown in figures 6 and 7), which are respectively section and elevation. The letters *a''*, *b''*, *c''*, *d''* corresponding to the letters *a'*, *b'*, *c'*, *d'*, in figure 2, with the addition of a collar at *e*, the object of which is to prevent a down-draught when the wind acts vertically upwards, or nearly so. In this case the inner cone or deflector may or may not be omitted. This ventilator is very suitable for and would be used by preference for smoke-flues, soil-pipes, &c.

The deflectors may be made broader or narrower, or the comparative distances between the rims may be made greater or less, as desired. The number of deflectors in each rim may be from two upwards, but by preference three or four. They may be, further, placed together in groups of two, three, four, or more, which may each be connected to separate or all to one upcast shaft. A plan of a group of four such is shown in figure 8. They may all be made of sheet, metal, or other suitable materials, which may be soldered, riveted, or otherwise fitted or put together.

The action of the wind, blowing in any direction whatever, on these modified forms of my new and improved ventilator, will be to induce a strong up-current in the upcast shafts to which they may be attached.

The chief novelty in this arrangement is the first or inner rim of deflectors, the presence of which will admit of the openings in the second or middle rim being made much wider in proportion than in any other existing ventilator, without fear of the weather entering, or a down-draught being created in the upcast shaft, and by this arrangement the power of the ventilator is considerably increased.

Figure 9 shows an arrangement for an inlet ventilator, which admits fresh air, but any rain, &c, entering in is not allowed to descend the downcast shaft, but passes over the lip at *x* and out again at the hooded aperture *y*. The arrangement of the various plates will at once show that the air-current passes forward and downward, as indicated by the arrows.

Figures 10 and 11 show sections of two forms of inlet ventilators for distributing the fresh air as it enters an apartment. Figure 10 has two conical envelopes, between which the air passes, thus entering the apartment in the form of an expanding hollow cone, being at once distributed and decreased in velocity, so that no draughts can be felt.

Figure 11 has two or more radial plates, which have a similar effect on an entering current as the arrangement last described.

And having thus particularly described my said invention, and the manner in which the same is to be performed, I have to state that I do not restrict myself to the precise details herein described or delineated; but that which I believe to be novel and original, and claim as the invention, is the combining of the parts of ventilators, substantially, in the improved modes herein described.

In witness whereof, I, the said Robert Newton Helme, have hereunto set my hand and seal, this first day of May, in the year of our Lord one thousand eight-hundred and eighty-four.

R. NEWTON HELME.

This is the specification referred to in the annexed Letters of Registration granted to Robert Newton Helme, the seventh day of July, A.D. 1884.

AUGUSTUS LOFTUS.

REPORT.

Sir,

The application of Mr. R. Newton Helme for Letters of Registration for invention of a "Pneumatic Ventilator" having been referred to us, we have examined the plans and specification accompanying the same, and have now the honor to report that we see no objection to the issue of Letters of Registration as prayed for.

We have, &c.,

JAMES BARNET.
EDMUND FOSBERY.

The Under Secretary of Justice.

[Drawings—one sheet.]

No. 1450.

[Assignment of No. 1261. See Letters of Registration for 1883, page 237.]

No. 1451.

[Assignment of No. 949. See Letters of Registration for 1881, page 187.]

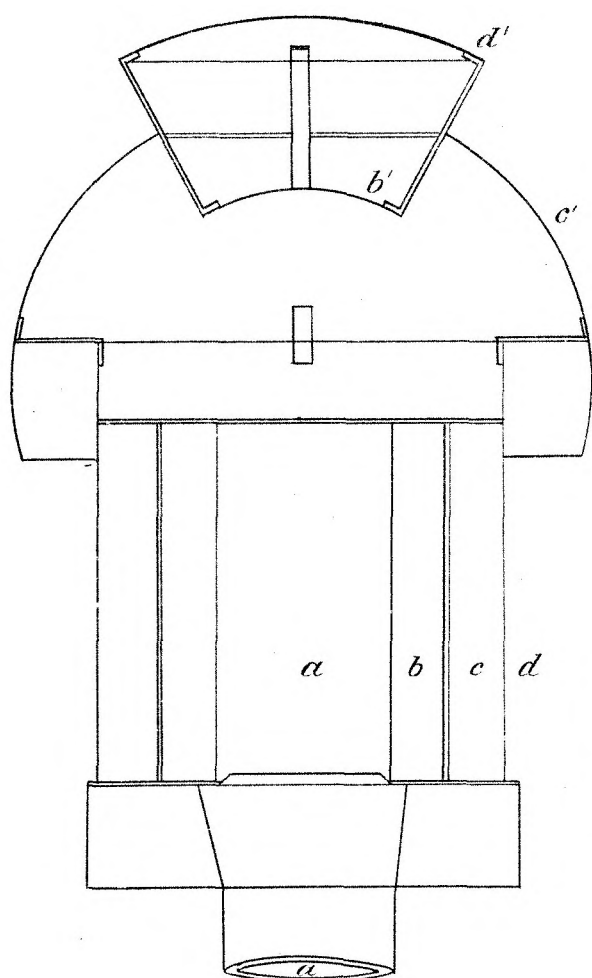


Fig: 2

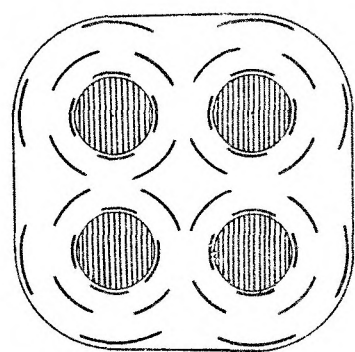


Fig: 5.

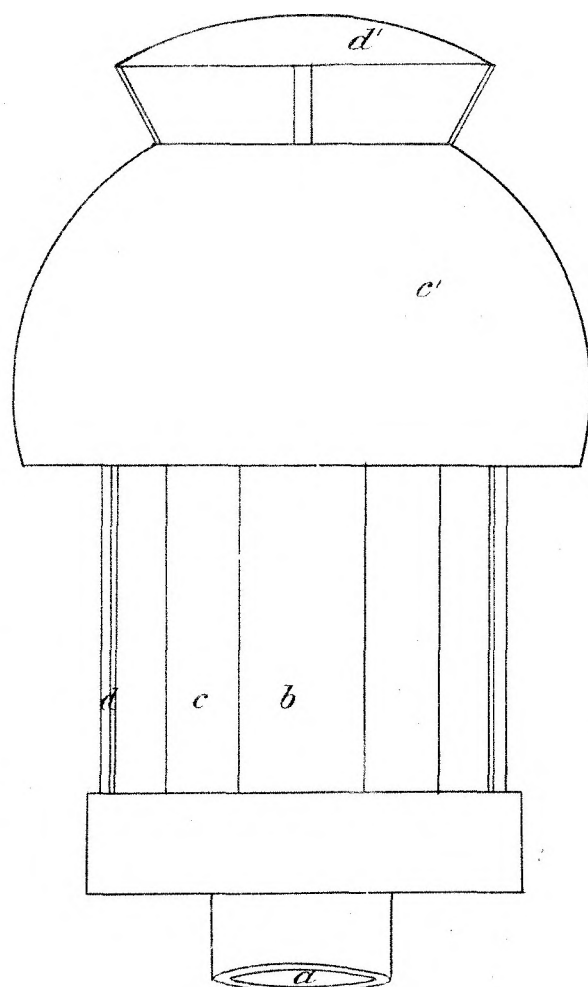


Fig: 3.

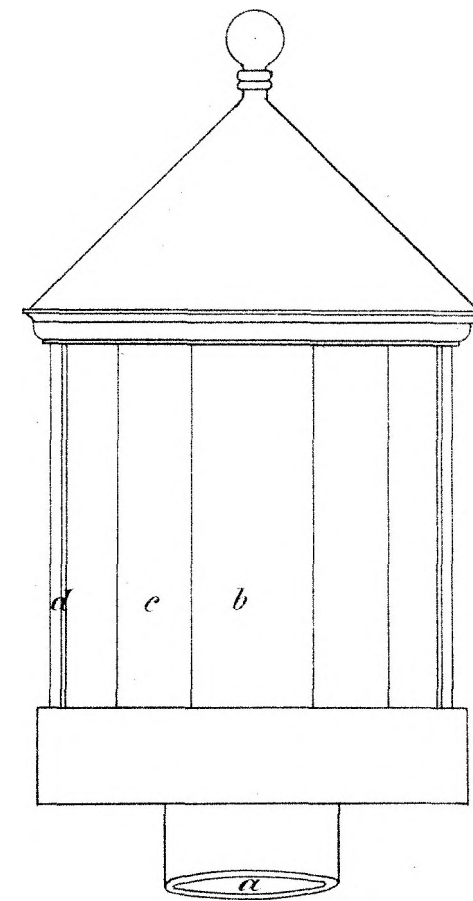


Fig: 5.

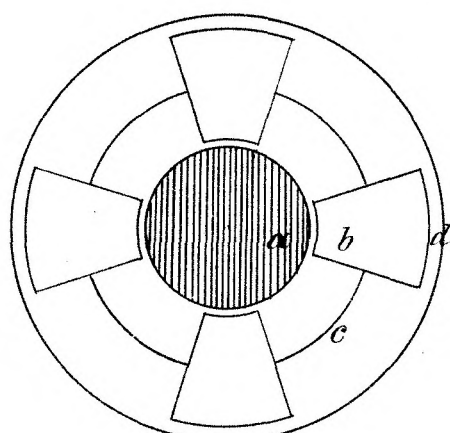


Fig: 1.

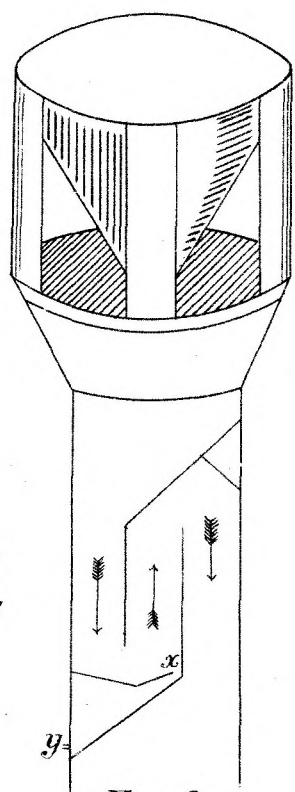


Fig: 9.

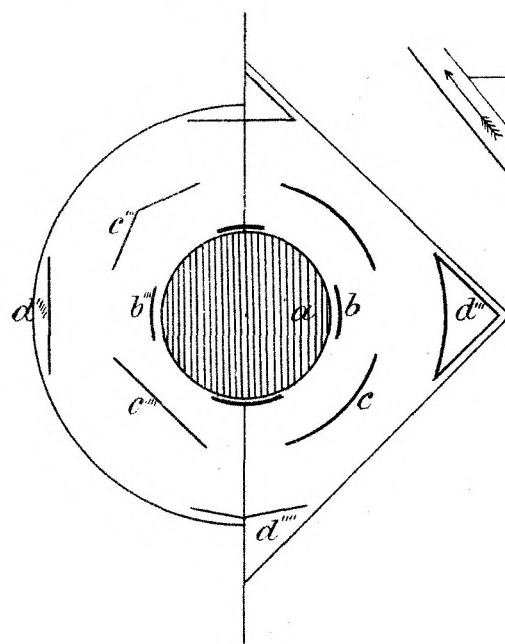


Fig: 4.

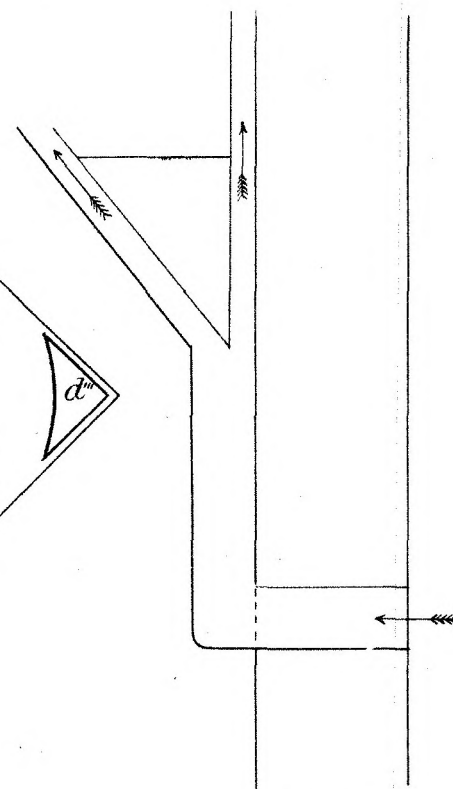


Fig: 10.

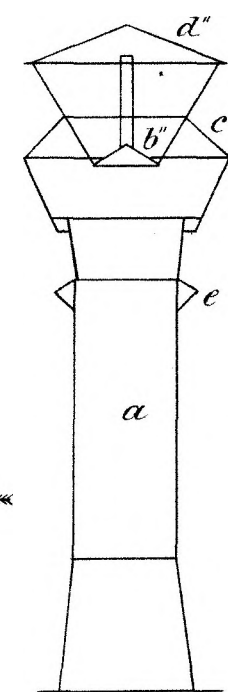


Fig: 6.

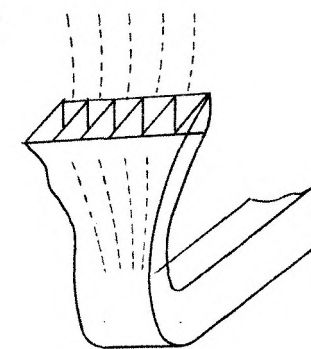


Fig: 11.

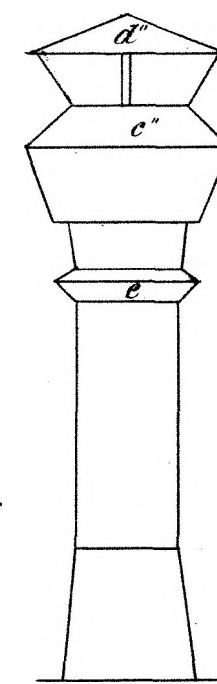


Fig: 7.

This is the Sheet of Drawings referred to in the annexed Letters of Registration, granted to Robert Newton Helme, the seventh day of July, A.D., 1884.

Augustus Loftus.



A.D. 1884, 7th July. No. 1452.

WINDOW SUPPORTER AND LOCK.

LETTERS OF REGISTRATION to David Moritz, for an invention entitled
"Window Supporter and Lock."

[Registered on the 10th day of July, 1884, in pursuance of the Act 16 Vic. No. 24.]

BY HIS EXCELLENCY THE RIGHT HONORABLE SIR AUGUSTUS WILLIAM FREDERICK SPENCER LOFTUS
(commonly called LORD AUGUSTUS LOFTUS), Knight, Grand Cross of the Most Honorable Order of
the Bath, a Member of Her Majesty's Most Honorable Privy Council, Governor and Commander-in-
Chief of the Colony of New South Wales and its Dependencies.

TO ALL TO WHOM THESE PRESENTS SHALL COME, greeting :

WHEREAS DAVID MORITZ, of Ulmarra, Clarence River, in the Colony of New South Wales, engineer, hath by his Petition humbly represented to me that he is the author or designer of a certain invention or improvement in manufactures, that is to say, of an invention entitled "Window Supporter and Lock," which is more particularly described in the specification and the sheet of drawings which are hereunto annexed ; and that he, the said Petitioner, hath deposited with the Honorable the Treasurer of the said Colony of New South Wales the sum of Twenty Pounds sterling, for defraying the expense of granting these Letters of Registration, as required by the Act of Council, sixteenth Victoria, number twenty-four ; and hath humbly prayed that I would be pleased to grant Letters of Registration whereby the exclusive enjoyment and advantage of the said invention or improvement might be secured to him for a period of fourteen years : And I, being willing to give encouragement to all inventions and improvements in the arts or manufactures which may be for the public good, and having received a report favourable to the prayer of the said Petition, from competent persons appointed by me to examine and consider the matters stated therein and to report thereon for my information, am pleased, with the advice of the Executive Council, and in exercise of the power and authority given to me by the said Act of Council, to grant, and do by these Letters of Registration grant unto the said David Moritz, his executors, administrators, and assigns, the exclusive enjoyment and advantage of the said invention or improvement for and during the term of fourteen years from the date hereof ; to have, hold, and exercise unto the said David Moritz, his executors, administrators, and assigns, the exclusive enjoyment and advantage thereof, for and during and unto the full end and term of fourteen years from the date of these presents next and immediately ensuing, and fully to be complete and ended : Provided always, that if the said David Moritz shall not, within three days after the granting of these Letters of Registration, register the same in the proper office in the Supreme Court, at Sydney, in the said Colony of New South Wales, then these Letters of Registration, and all advantages whatsoever hereby granted, shall cease and become void.

In witness whereof, I have hereunto set my sign manual, and have caused the present Letters of Registration to be sealed with the seal of the said Colony of New South Wales, at Government House, Sydney, in New South Wales, this seventh day of July, in the year of our Lord one thousand eight hundred and eighty-four.

[L.S.]

AUGUSTUS LOFTUS.

Window Supporter and Lock.

SPECIFICATION of Improvements claimed for DAVID MORITZ's Sash Supporter and Lock.

THIS invention consists of a window-fastener or sash-supporter which is in the shape of the end of an oval. It is secured to the sash by a pivot screw, upon which it turns, the pivot being in the long diameter. It may be made of brass or iron, or any other metal or combination of metals, or any other material sufficiently dense to stand the necessary strain. Its action is that of an eccentric by reason of the axis being removed from the centre, and it holds the sash firmly in any position that may be desired, thus dispensing with sash lines, pulley axles, and counterpoise weights. It also prevents vibration and rattling, which is sometimes very annoying with windows not so fastened.

This invention may be used in the form shown on figure 1 of the accompanying sheet of drawings, by being fastened to the sash style of any window. By means of the pivot screw the oval end of the fastener is placed against the jamb strip, and the window is held at any desired elevation. It also may be used in conjunction with a spiral-spring attachment as shown at figure 2 in the sheet of drawings annexed hereto; the action is then automatic, the spring keeping the fastener pressed against the jamb strip in position to support the sash at any required elevation, or by turning the fastener upwards the spring keeps it in position to act as a window lock. The spring may either be enclosed or not. The invention may also be used in the form shown at figure 3 in the annexed sheet of drawings, with interior tumbler spring to cause automatic action in the same way as the spiral spring, by keeping the fastener, when set either upwards or downwards, pressed against the jamb strip.

Generally, it is claimed for this invention that it will hold the sash at any elevation desired; that it is automatic in action, simple in construction, easy of management; that by its use boxed frames are not necessary for window-sashes, and consequently sashes may be removed with more facility, and in the case of upholstered carriages, they may be removed without disturbing the upholstery. The invention is applicable to either single or double hung sashes, and is equally adapted for the windows of houses, railway carriages, omnibuses, or other vehicles. The sash-fastener may be either larger or smaller than the size shown on annexed plan, and the oval edge may be plain or milled, or covered with rubber or any other material that will help it to grip more firmly.

REFERENCE TO ANNEXED SHEET OF DRAWINGS.

- Figure 1 shows simple form of window supporter.
 Figure 1A shows side view of window supporter.
 Figure 2 shows window supporter and spiral-spring attachment.
 Figure 3 shows form of window supporter in metal case with interior tumbler spring.
 Figure 4 shows figure 3 with tumbler removed to show action of tumbler spring *aa*.
 Figure 5 shows reverse side of tumbler with small axle-wheel *b* upon which the tumbler spring works.
 Figure 6 shows position of tumbler when window is locked.
 Figure 7 shows window when supported open by the window supporter with spiral-spring attachment.

DAVID MORITZ,
 Engineer.

This is the specification referred to in the annexed Letters of Registration granted to David Moritz, this 7th day of July, A.D. 1884.

AUGUSTUS LOFTUS.

REPORT.

Sir, The application of Mr. David Moritz for Letters of Registration for an invention entitled "Window Supporter and Lock" having been referred to us, we have examined the plans and specifications accompanying the same, and have now the honor to report that we see no objection to the issue of Letters of Registration as prayed for.

We have, &c.,

JAMES BARNET,
 WILLIAM C. BENNETT.

The Under Secretary of Justice.

Sydney, 23 May, 1884.

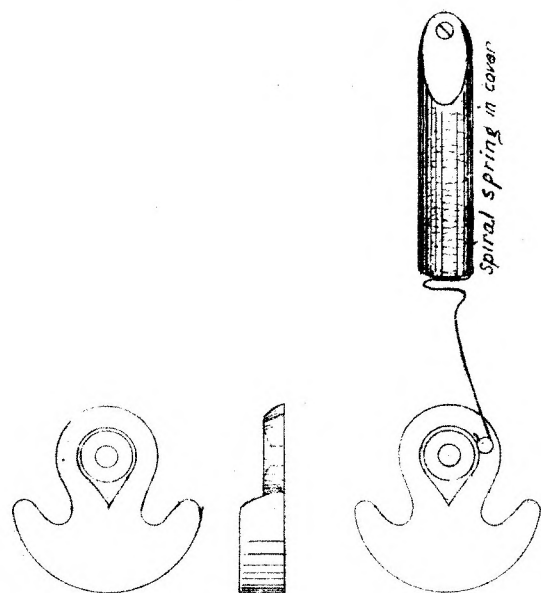


Fig 1 Fig. 1A Fig 2.

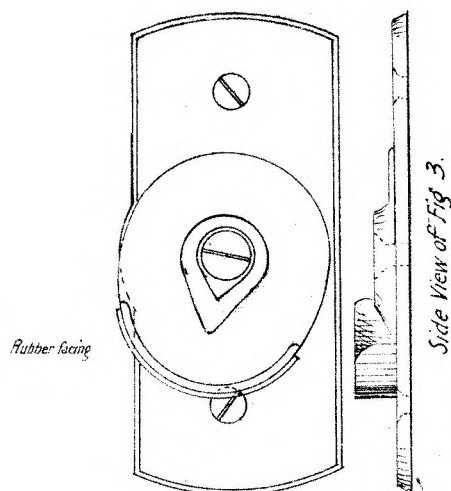


Fig. 3.

DAVID MORITZ'S
Sash Supporter & Lock

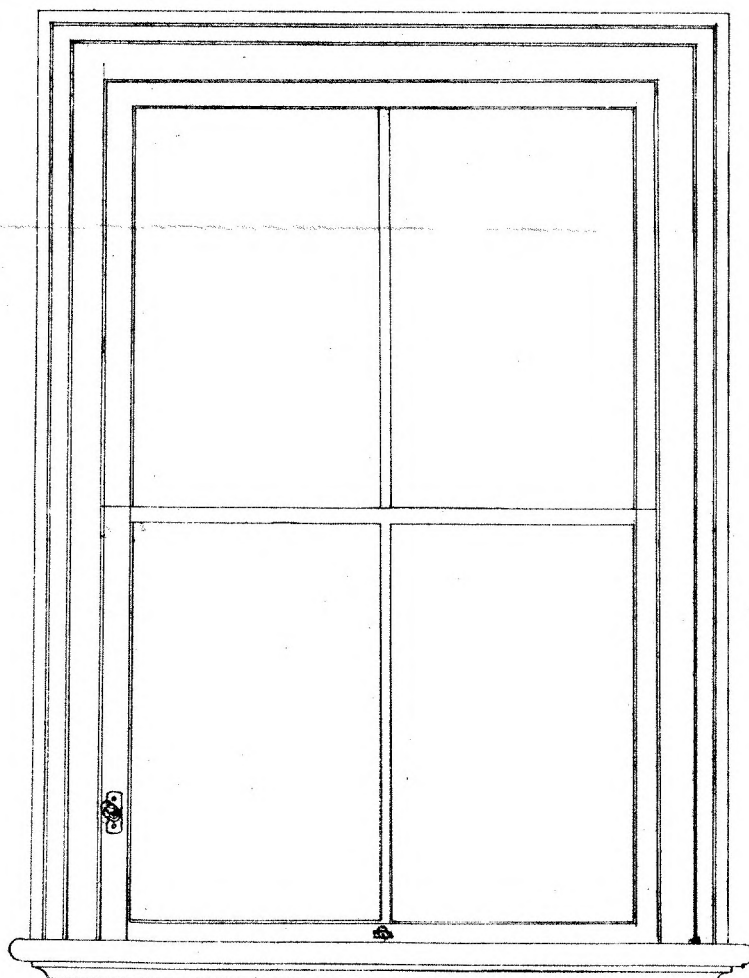


Fig. 6.

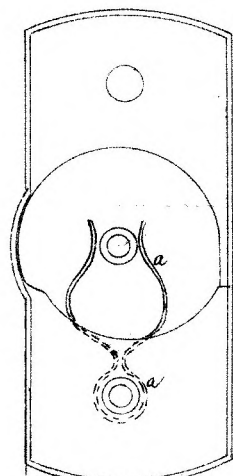


Fig 4.

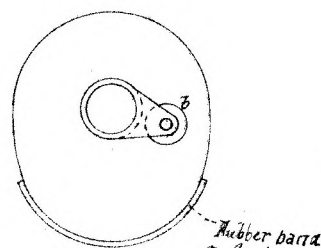


Fig 5.

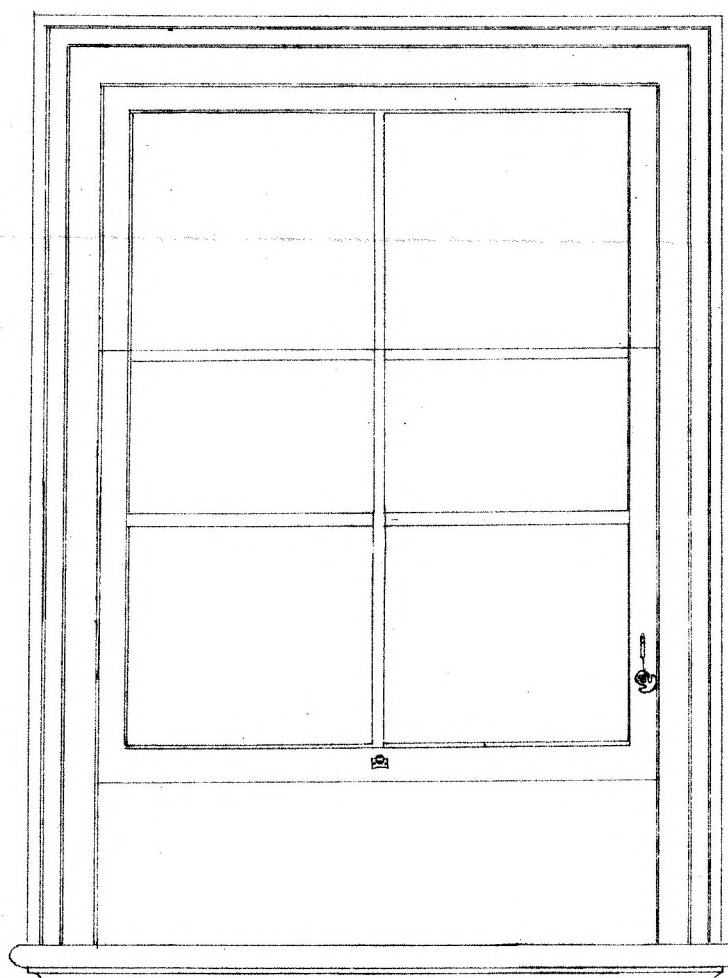


Fig. 7.

This is the Sheet of Drawings referred to in the annexed Letters of Registration, granted to David Moritz, the seventh day of July, A. D., 1884.

Augustus Loftus.

David Moritz Engineer

(Sig: 245~)



A.D. 1884, 7th July. No. 1453.

AN IMPROVED PROCESS OF TREATING FINELY-DIVIDED AURIFEROUS MATERIAL PRIOR TO SMELTING IT.

LETTERS OF REGISTRATION to John Dye La Monte, for an improved process of treating finely-divided auriferous material prior to smelting it.

[Registered on the 10th day of July, 1884, in pursuance of the Act 16 Vic. No. 24.]

BY HIS EXCELLENCY THE RIGHT HONORABLE SIR AUGUSTUS WILLIAM FREDERICK SPENCER LOFTUS (commonly called LORD AUGUSTUS LOFTUS), Knight Grand Cross of the Most Honorable Order of the Bath, a Member of Her Majesty's Most Honorable Privy Council, Governor and Commander-in-Chief of the Colony of New South Wales and its Dependencies.

TO ALL TO WHOM THESE PRESENTS SHALL COME, greeting :

WHEREAS JOHN DYE LA MONTE, of Sydney, in the Colony of New South Wales, metallurgist, hath by his Petition humbly represented to me that he is the author or designer of a certain invention or improvement in manufactures, that is to say, of an invention entitled "An improved process of treating finely-divided auriferous material prior to smelting it," which is more particularly described in the specification and the sheet of drawings which are hereunto annexed; and that he, the said Petitioner, hath deposited with the Honorable the Treasurer of the said Colony of New South Wales the sum of Twenty Pounds sterling, for defraying the expense of granting these Letters of Registration, as required by the Act of Council, sixteenth Victoria, number twenty-four; and hath humbly prayed that I would be pleased to grant Letters of Registration, whereby the exclusive enjoyment and advantage of the said invention or improvement might be secured to him for a period of fourteen years: And I, being willing to give encouragement to all inventions and improvements in the arts or manufactures which may be for the public good, and having received a report favourable to the prayer of the said Petition, from competent persons appointed by me to examine and consider the matters stated therein and to report thereon for my information, am pleased, with the advice of the Executive Council, and in exercise of the power and authority given to me by the said Act of Council, to grant, and do by these Letters of Registration grant unto the said John Dye La Monte, his executors, administrators, and assigns, the exclusive enjoyment and advantage of the said invention or improvement, for and during the term of fourteen years from the date hereof; to have, hold, and exercise unto the said John Dye La Monte, his executors, administrators, and assigns, the exclusive enjoyment and advantage thereof, for and during and unto the full end and term of fourteen years from the date of these presents next and immediately ensuing, and fully to be complete and ended: Provided always, that if the said John Dye La Monte shall not, within three days after the granting of these Letters of Registration, register the same in the proper office in the Supreme Court, at Sydney, in the said Colony of New South Wales, then these Letters of Registration, and all advantages whatsoever hereby granted shall cease and become void.

In witness whereof, I have hereunto set my sign manual, and have caused the present Letters of Registration to be sealed with the seal of the said Colony of New South Wales, at Government House, Sydney, in New South Wales, this seventh day of July, in the year of our Lord one thousand eight hundred and eighty-four.

[L.S.]

AUGUSTUS LOFTUS.

An improved process of treating finely-divided auriferous material prior to smelting it.

SPECIFICATION of JOHN DYE LA MONTE, of Sydney, in the Colony of New South Wales, metallurgist, for an invention entitled "An improved process of treating finely-divided auriferous material prior to smelting it."

My improved process of treating finely-divided auriferous material prior to smelting consists in passing it through a bath of molten lead or base bullion, and then cooling it by a cold-water spray so as to matt the mass in small quantities before submitting it to the action of the smelting furnace. This enables the various particles to take up a certain portion of the molten lead or base bullion as a coating, so that when they are placed in the smelting furnace the lead or base bullion when melted will descend in a shower from all parts of the charge, carrying with it any gold it may meet in its passage. This lead amalgam or base bullion is finally drawn off in the usual way, and in its then form may be taken to the lead bath and re-used in the same way until it becomes sufficiently rich for "parting" or "refining."

The lead or base bullion bath, as the case may be, should be kept just below a dull red heat so as to prevent its fuming, and the percentage of lead or base bullion taken up by the auriferous material may be determined by the size of the particles of material treated; the smaller the particles, the larger the percentage.

One form of lead or base bullion bath, such as I have described, is illustrated in the drawing hereto attached, where A is the cast-iron bath, B the supply passage for the auriferous material, C an iron plunger, D a hopper, E the chimney stack, F the fire grate, G fire-brick arch, H furnace door, I the ore floor.

The material to be treated falls through the bottom of hopper D into the passage B, from whence it is forced by the reciprocating action of plunger C into the bath A containing molten lead or base bullion. As it rises to the top it is skimmed off on to the floor I, where it is cooled by cold-water spray, and is then removed to the smelting furnace.

I am aware that lead has been used for a long time past in processes for smelting auriferous material; but in such cases the lead, in whatever form used, has been ground up and mixed with the auriferous material in the smelting furnace, each particle of lead being separate from each particle of auriferous material. Now, my invention consists in mixing the lead or base bullion with the auriferous material *before* it enters the smelting furnace, so that each particle or conglomeration of particles is coated with the lead or base bullion, as by so doing it becomes almost a certainty that each particle will come into contact with the melted lead or base bullion, and thus the result of the smelting operation be greatly improved.

I do not claim, therefore, the use of lead in the smelting of auriferous material; but what I believe to be new, and therefore claim as my improved process of treating finely-divided auriferous material prior to smelting it, is: The subjecting of such material to the action of a bath of molten lead or base bullion, and then cooling it by cold-water spray prior to placing it in the smelting furnace, substantially as herein described and explained.

In witness whereof, I, the said John Dye La Monte, have hereto set my hand and seal, this — day of — one thousand eight hundred and eighty-four.

JOHN D. LA MONTE.

Witness—

CHARLES KAHLO,
Sydney, N.S.W., U.S. Consul.

This is the specification referred to in the annexed Letters of Registration granted to John Dye La Monte, the seventh day of July, A.D. 1884.

AUGUSTUS LOFTUS.

REPORT.

Sir,

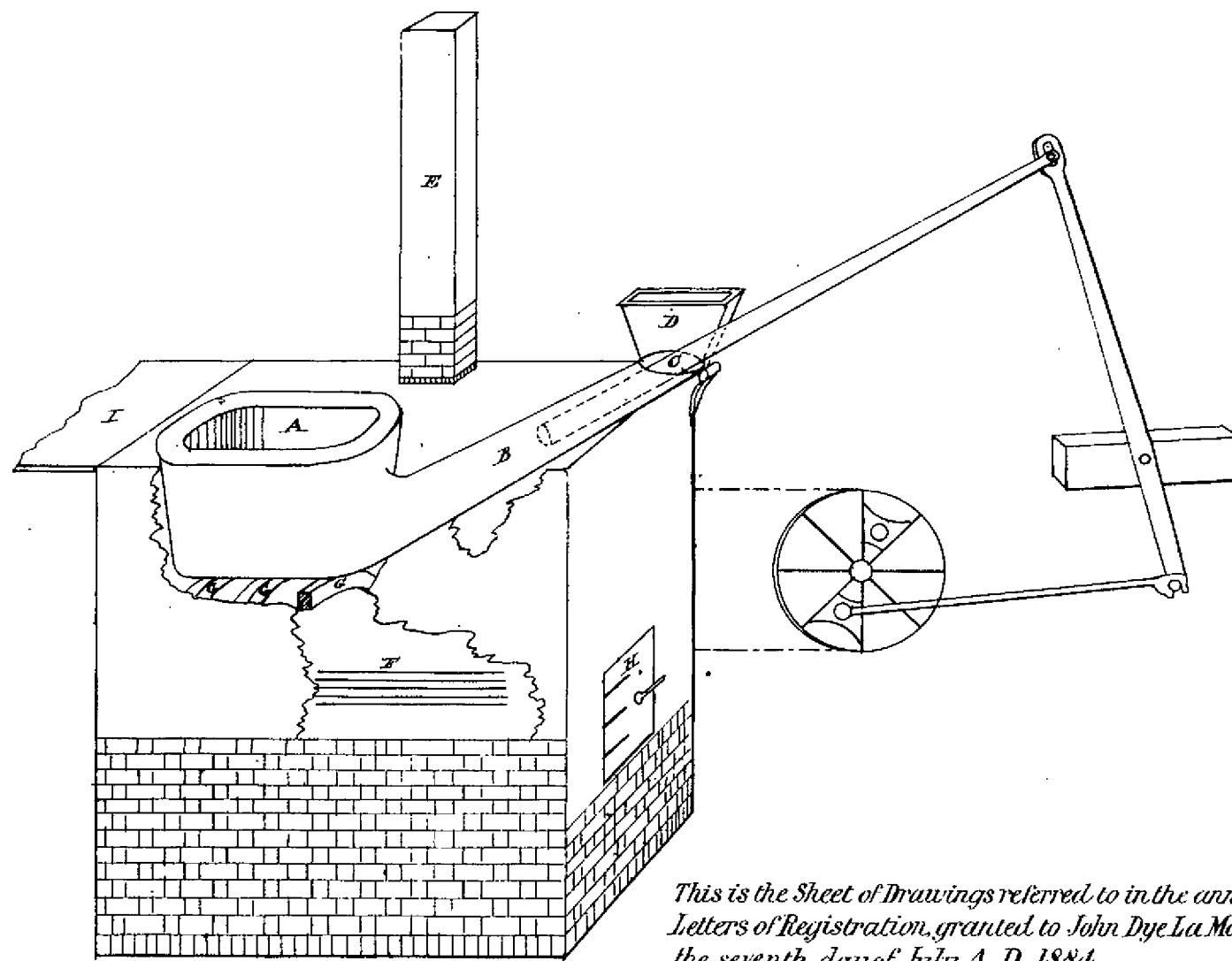
The petition of Mr. John Dye La Monte for Letters of Registration for an invention entitled "An improved process of treating finely-divided auriferous material prior to smelting it," having been referred to us, we have examined the specification and drawing accompanying the same, and have now the honor to report that we see no objection to the issue of Letters of Registration as prayed for.

We have, &c.,

J. SMITH.

A. LEIBIUS.

The Under Secretary of Justice.



*This is the Sheet of Drawings referred to in the annexed
Letters of Registration, granted to John Dye La Monte,
the seventh day of July, A. D., 1884.*

Augustus Loftus.



A.D. 1884, 8th July. No. 1454.

THE NEVER-FAILING HAIR RESTORER.

LETTERS OF REGISTRATION to William Jones, for an Invention entitled "The Never-failing Hair Restorer."

[Registered on the 10th day of July, 1884, in pursuance of the Act 16 Vic. No. 24.]

BY HIS EXCELLENCY THE RIGHT HONORABLE SIR AUGUSTUS WILLIAM FREDERICK SPENCER LOFTUS (commonly called LORD AUGUSTUS LOFTUS), Knight Grand Cross of the Most Honorable Order of the Bath, a Member of Her Majesty's Most Honorable Privy Council, Governor and Commander-in-Chief of the Colony of New South Wales and its Dependencies.

TO ALL TO WHOM THESE PRESENTS SHALL COME, greeting :

WHEREAS WILLIAM JONES, of the Richmond River, in the Colony of New South Wales, builder, hath by his Petition humbly represented to me that he is the author or designer of a certain invention or improvement in manufactures, that is to say, of an invention entitled "The Never-failing Hair Restorer," which is more particularly described in the specification which is hereunto annexed ; and that he, the said Petitioner, hath deposited with the Honorable the Treasurer of the said Colony of New South Wales the sum of Twenty Pounds sterling, for defraying the expence of granting these Letters of Registration, as required by the Act of Council, sixteenth Victoria, number twenty-four ; and hath humbly prayed that I would be pleased to grant Letters of Registration, whereby the exclusive enjoyment and advantage of the said invention or improvement might be secured to him for a period of fourteen years : And I, being willing to give encouragement to all inventions and improvements in the arts or manufactures which may be for the public good, and having received a report favourable to the prayer of the said Petition, from competent persons appointed by me to examine and consider the matters stated therein and to report thereon for my information, am pleased, with the advice of the Executive Council, and in exercise of the power and authority given to me by the said Act of Council, to grant, and do by these Letters of Registration grant unto the said William Jones, his executors, administrators, and assigns, the exclusive enjoyment and advantage of the said invention or improvement, for and during the term of fourteen years from the date hereof ; to have, hold, and exercise unto the said William Jones, his executors, administrators, and assigns, the exclusive enjoyment and advantage thereof, for and during and unto the full end and term of fourteen years from the date of these presents next and immediately ensuing, and fully to be complete and ended : Provided always, that if the said William Jones shall not, within three days after the granting of these Letters of Registration, register the same in the proper office in the Supreme Court, at Sydney, in the said Colony of New South Wales, then these Letters of Registration, and all advantages whatsoever hereby granted, shall cease and become void.

In witness whereof, I have hereunto set my sign manual, and have caused the present Letters of Registration to be sealed with the seal of the said Colony of New South Wales, at Government House, Sydney, in New South Wales, this eighth day of July, in the year of our Lord one thousand eight hundred and eighty-four.

[L.S.]

AUGUSTUS LOFTUS.



A.D. 1884, 8th July. No. 1455.

AN IMPROVED COUPLING FOR THE RODS OF BORING MACHINES.

LETTERS OF REGISTRATION to William Wright, for an Improved Coupling for the Rods of those Boring Machines whose Rods have a jumping motion.

[Registered on the 10th day of July, 1884, in pursuance of the Act 16 Vic. No. 24.]

BY HIS EXCELLENCY THE RIGHT HONORABLE SIR AUGUSTUS WILLIAM FREDERICK SPENCER LOFTUS (commonly called LORD AUGUSTUS LOFTUS), Knight Grand Cross of the Most Honorable Order of the Bath, a Member of Her Majesty's Most Honorable Privy Council, Governor and Commander-in-Chief of the Colony of New South Wales and its Dependencies.

TO ALL TO WHOM THESE PRESENTS SHALL COME, greeting :

WHEREAS WILLIAM WRIGHT, of Nos. 99 and 101, Little Bourke-street West, in the City of Melbourne, and Colony of Victoria, engineer, hath by his Petition humbly represented to me that he is the author or designer of a certain invention or improvement in manufactures, that is to say, of an invention entitled "An Improved Coupling for the Rods of those Boring Machines whose Rods have a jumping motion," which is more particularly described in the specification and the sheet of drawings which are hereunto annexed; and that he, the said Petitioner, hath deposited with the Honorable the Treasurer of the said Colony of New South Wales the sum of Twenty Pounds sterling, for defraying the expense of granting these Letters of Registration, as required by the Act of Council, sixteenth Victoria, number twenty-four; and hath humbly prayed that I would be pleased to grant Letters of Registration, whereby the exclusive enjoyment and advantage of the said invention or improvement might be secured to him for a period of fourteen years: And I, being willing to give encouragement to all inventions and improvements in the arts or manufactures which may be for the public good, and having received a report favourable to the prayer of the said Petition, from competent persons appointed by me to examine and consider the matters stated therein and to report thereon for my information, am pleased, with the advice of the Executive Council, and in exercise of the power and authority given to me by the said Act of Council, to grant, and do by these Letters of Registration grant unto the said William Wright, his executors, administrators, and assigns, the exclusive enjoyment and advantage of the said invention or improvement for and during the term of fourteen years from the date hereof; to have, hold, and exercise unto the said William Wright, his executors, administrators, and assigns, the exclusive enjoyment and advantage thereof, for and during and unto the full end and term of fourteen years from the date of these presents next and immediately ensuing, and fully to be complete and ended: Provided always, that if the said William Wright shall not, within three days after the granting of these Letters of Registration, register the same in the proper office in the Supreme Court at Sydney, in the said Colony of New South Wales, then these Letters of Registration, and all advantages whatsoever hereby granted, shall cease and become void.

In witness whereof, I have hereunto set my sign manual, and have caused the present Letters of Registration to be sealed with the seal of the said Colony of New South Wales, at Government House, Sydney, in New South Wales, this eighth day of July, in the year of our Lord one thousand eight hundred and eighty-four.

[L.S.]

AUGUSTUS LOFTUS.

An Improved Coupling for the Rods of Boring Machines.

SPECIFICATION of WILLIAM WRIGHT, of Nos. 99 and 101, Little Bourke-street West, in the City of Melbourne, and Colony of Victoria, engineer, for an invention entitled "An Improved Coupling for the Rods of those Boring Machines whose Rods have a jumping motion."

THIS invention consists of an improved coupling for the rods of those boring machines whose rods have a jumping motion, and is for the purpose of lessening the jar to such rods when they are boring in rock. My coupling consists of a cylindrical box, in which is placed a spring or springs of any description or material, and the extremities of which are tapped on the inside so as to screw on to their connections. The lower extremity is screwed on to the top of a boring rod made in the ordinary manner, but the upper extremity is made to screw on to a nut which works loosely on its rod and is kept from falling off (when disconnected) by means of a piston or buffer, which enters said cylindrical box and rests on the spring therein. These couplings may be used at intervals as required.

Referring to my drawings, fig. 1 shows a boring rod, and fig. 2 a spring cylinder, both made according to my invention, but disconnected; and fig. 3 shows them coupled together; fig. 4 is a plan on top of the connecting nut. In these figures, A is the cylindrical box, having a suitable thread at its top to receive the nut B, and having a tapped socket A¹ at its bottom to receive the end of the ordinary boring rod; C is the spring which is seated on the partition A²; and D is the buffer or piston which rests on said spring. Said buffer is formed on the rod D¹, which passes through the hole provided for it in the nut B.

Having thus described the nature of my invention, and the manner of performing same, I would have it understood that what I believe to be new, and therefore claim as of my invention, is the use of springs in the couplings of the rods of those boring machines in which the rods have a jumping motion, substantially as herein described and explained.

In witness whereof, I, the said William Wright, have hereto set my hand and seal, this third day of April, one thousand eight hundred and eighty-four.

Witness—ROBT. ANDERSON.

WILLIAM WRIGHT.

This is the specification referred to in the annexed Letters of Registration granted to William Wright, the eighth day of July, A.D. 1884.

AUGUSTUS LOFTUS.

REPORT.

Sir,

Sydney, 5 May, 1884.

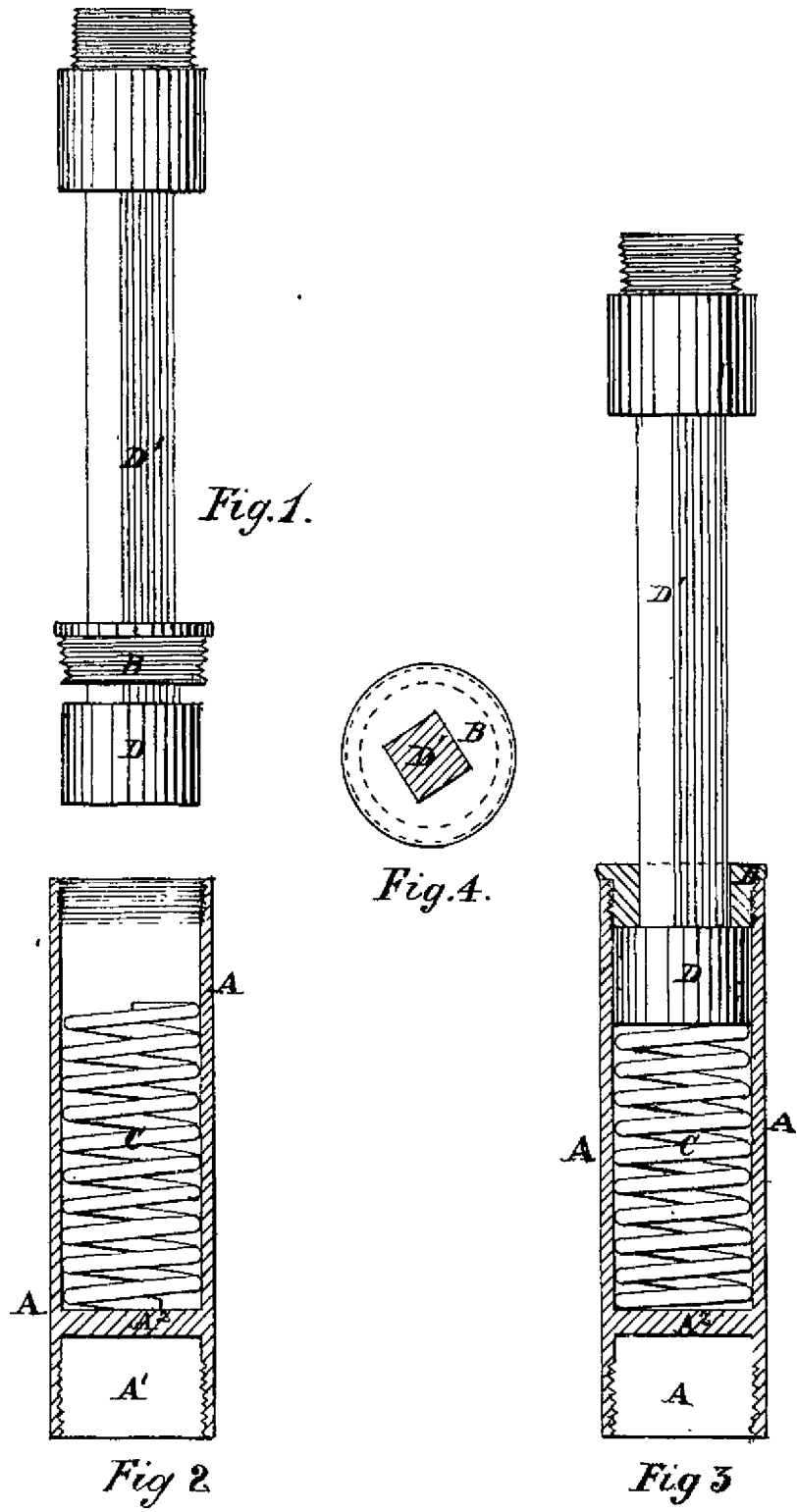
The application of Mr. William Wright for Letters of Registration for "An improved coupling for the rods of those boring machines whose rods have a jumping motion," having been referred to us, we have examined the plans and specifications accompanying the same, and have now the honor to report that we see no objection to the issue of Letters of Registration as prayed for.

We have, &c.,

JAMES BARNET.

WILLIAM C. BENNETT.

The Under Secretary of Justice.



This is the Sheet of Drawings referred to in the annexed Letters of Registration, granted to William Wright, the eighth day of July, A. D., 1884.

Augustus Loftus.

(245-)



A.D. 1884, 11th July. No. 1456.

PROCESS AND APPARATUS FOR BARYTA OR STRONTIA TREATMENT OF
SACCHARINE LIQUORS, &c.

LETTERS OF REGISTRATION to Hippolyte Leplay, for Process and Apparatus
for Baryta or Strontia treatment of Saccharine Liquors, and for production
and recovery of these reagents.

[Registered on the 14th day of July, 1884, in pursuance of the Act 16 Vic. No. 24.]

BY HIS EXCELLENCY THE RIGHT HONORABLE SIR AUGUSTUS WILLIAM FREDERICK SPENCER LOFTUS
(commonly called LORD AUGUSTUS LOFTUS), Knight Grand Cross of the Most Honorable Order of
the Bath, a Member of Her Majesty's Most Honorable Privy Council, Governor and Commander-in-
Chief of the Colony of New South Wales and its Dependencies.

TO ALL TO WHOM THESE PRESENTS SHALL COME, greeting :

WHEREAS HIPPOLYTE LEPLAY, of Paris, in the Republic of France, chemist, hath by his Petition
humbly represented to me that he is the author or designer of a certain invention or improvement in
manufactures, that is to say, of an invention entitled "Process and Apparatus for Baryta or Strontia
treatment of Saccharine Liquors, and for production and recovery of these reagents," which is more
particularly described in the specification and the drawing which are hereunto annexed; and that
he, the said Petitioner, hath deposited with the Honorable the Treasurer of the said Colony of New South
Wales the sum of Twenty Pounds sterling, for defraying the expense of granting these Letters of Registration,
as required by the Act of Council, sixteenth Victoria, number twenty-four; and hath humbly prayed that I
would be pleased to grant Letters of Registration, whereby the exclusive enjoyment and advantage of the
said invention or improvement might be secured to him for a period of fourteen years: And I, being willing
to give encouragement to all inventions and improvements in the arts or manufactures which may be for
the public good, and having received a report favourable to the prayer of the said Petition, from competent
persons appointed by me to examine and consider the matters stated therein and to report thereon for my
information, and pleased, with the advice of the Executive Council, and in exercise of the power and
authority given to me by the said Act of Council, to grant, and do by these Letters of Registration grant
unto the said Hippolyte Leplay, his executors, administrators, and assigns, the exclusive enjoyment and
advantage of the said invention or improvement, for and during the term of fourteen years from the date
hereof; to have, hold, and exercise unto the said Hippolyte Leplay, his executors, administrators, and
assigns, the exclusive enjoyment and advantage thereof, for and during and unto the full end and term of
fourteen years from the date of these presents next and immediately ensuing, and fully to be complete and
ended: Provided always, that if the said Hippolyte Leplay shall not, within three days after the granting of
these Letters of Registration, register the same in the proper office in the Supreme Court, at Sydney, in the
said Colony of New South Wales, then these Letters of Registration, and all advantages whatsoever hereby
granted, shall cease and become void.

In witness whereof, I have hereunto set my sign manual, and have caused the present Letters of
Registration to be sealed with the seal of the said Colony of New South Wales, at Government
House, Sydney, in New South Wales, this eleventh day of July, in the year of our Lord one
thousand eight hundred and eighty-four.

[L.S.]

AUGUSTUS LOFTUS.

Process and Apparatus for Baryta or Strontia treatment of Saccharine Liquors, &c.

SPECIFICATION of HIPPOLYTE LEPLAY, of Paris, in the Republic of France, chemist, for an invention entitled "Process and apparatus for baryta or strontia treatment of saccharine liquors, and for production and recovery of these reagents."

In treating saccharine liquors such as beet juice or molasses with hydrates of the alkaline earths, baryta and strontia, there is considerable difficulty and loss in dealing with the large quantity of liquid resulting from the treatment, and there is great expense in providing fresh supplies of these reagents.

My invention has for its object to overcome these objections by producing and employing the reagents in the condition of low hydrates, or, as they may be termed, monohydrates, and by recovering them, after they have effected treatment of saccharine liquor, in a condition suitable for subsequent use.

I will first describe the process and apparatus, according to my invention, for applying the monohydrate of baryta or strontia to saccharine liquor, referring to the accompanying drawing which is a vertical section of a vessel suitable for the purpose. A is a strong closed vessel like a boiler, having bolted on it a cover F with manhole F', safety valve Q, pressure gauge H, and thermometer I. A steam-pipe J communicates with the lower and upper parts of the vessel by stop cocks or valves J', J'', J'''; the lower and upper parts communicate by a pipe provided with stop cocks or valves L, L'. The vessel is also provided with other cocks or valves G for escape of air, M for admitting the liquor, N for decanting liquid from the precipitate, O for admitting boiling water under pressure, K for emptying. Near the bottom is fixed a finely perforated screen B, and about midway in the vessel a grating C is supported on an angle-iron E, this grating having a rod D by which it can be lifted out when the cover is removed. P is a manhole for discharge of sucrate. The monohydrate is introduced through the manhole F' in fragments, which rest on the grating C, and the saccharine juice boiling is then admitted by M in sufficient quantity to fill the lower part of the vessel and cover the grating C, so that the monohydrate becomes dissolved by it. The manhole F' being now closed, steam is admitted by J'' to blow through the liquid, escape being open at G. When all the monohydrate is dissolved, G is closed and the pressure is raised to several atmospheres. J'' is then closed, and in a few minutes the precipitate of sucrate of baryta or strontia subsides on the screen B. The cocks L, L' are then opened so as to equalize the pressure above and below the deposit of sucrate, and K is gradually opened, allowing the mother liquor to escape. Then boiling water or a boiling weak solution of the alkaline earth injected by O is broken up by the grating C and falls in a shower upon the sucrate, through which it passes, washing it. During the washing the cock K is almost closed so as to maintain considerable pressure within the vessels. When the sucrate is sufficiently washed the cock L is closed, and steam blowing through from above effects drainage of the precipitate. The hole P is then opened and the precipitate is raked out and transferred to a vessel to be treated with carbonic acid. It is of advantage to use monohydrate somewhat in excess, as the excess may in great part be recovered in condition of hydrate by concentration of the mother liquor. When baryta is employed pressure is not necessary, and therefore the vessel may be opened. Strontia, however, is generally to be preferred, as it is innocuous. When the liquor to be treated is in a thick condition, such as that of molasses, it should be diluted sufficiently with water to make it freely dissolve the monohydrate.

The sucrate of baryta or strontia obtained as above described is treated in the usual way with carbonic acid, so as to precipitate carbonate of baryta or strontia from the syrup, which is separated from the carbonate by decanting and filter pressing.

In order to produce the monohydrate from the carbonate, or to recover the monohydrate for subsequent use, the carbonate is moulded into forms presenting extended surface; a very advantageous form is that of a short tube like a drain-pipe. These moulded pieces are heated in a furnace, and while hot are subjected to the action of superheated steam, which has the effect of driving off the carbonic acid, and causing the material to assume the condition of monohydrate or low hydrate, which fuses, and can be run off the furnace by a tapping hole. This process when applied to carbonate of baryta presents little difficulty, but when applied to the carbonate of strontia it requires very careful adjustment of the temperature. I therefore prefer to deal with the carbonate of strontia in the following manner:—I heat the moulded pieces and subject them to the action of superheated steam. If the temperature somewhat exceeds that which produces monohydrate in fusion, the result is that the carbonate is converted into an hydrate which is in the form of hard pieces. I break these pieces into fragments and mix them with crystals of ordinary hydrate of strontia, which may be that recovered from the mother liquor and wash liquor in the saccharine treatment above described. By the mixture of the anhydrate with the hydrate a vigorous action is set up, accompanied by heat, that causes considerable evaporation of water, and the result of the action is a monohydrate or low hydrate suitable for the treatment of fresh doses of saccharine liquor.

I claim as my invention—

First—Treating saccharine liquor with monohydrate or low hydrate of baryta or strontia, so as to obtain sucrate of baryta or strontia for subsequent treatment with carbonic acid, substantially as herein described.

Second—The apparatus for treating saccharine liquor, substantially as described with reference to the accompanying drawing.

Third—Producing or recovering monohydrate or low hydrate of baryta or strontia by heating the carbonate and subjecting it to the action of superheated steam.

Fourth—Producing monohydrate or low hydrate of strontia by mixing ordinary hydrate with fragments of anhydrate produced by the action of superheated steam on heated carbonate.

In witness whereof, I, the said Hippolyte Leplay, have hereunto set my hand and seal, this first day of April, in the year of our Lord one thousand eight hundred and eighty-four.

HIPPOLYTE LEPLAY.

This is the specification referred to in the annexed Letters of Registration granted to Hippolyte Leplay, the eleventh day of July, A.D. 1884.

AUGUSTUS LOFTUS.

REPORT.

Process and Apparatus for Baryta or Strontia treatment of Saccharine Liquors, &c.

REPORT.

Sir,

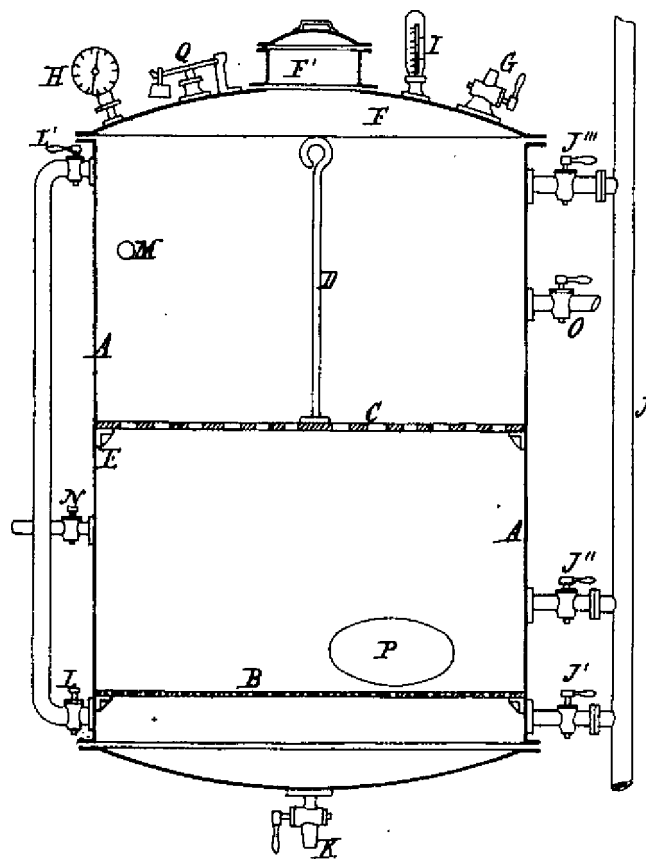
Sydney, 27 May, 1884.

In the matter of the application of Mr. Hyppolyte Leplay for Letters of Registration for a "Process and apparatus for baryta or strontia treatment of saccharine liquors," which has been referred to us, we have examined the specification and drawing accompanying the same, and have now the honor to report that we see no objection to the issue of Letters of Registration as prayed for.

We have, &c.,
J. SMITH.
A. LEIBIUS.

The Under Secretary of Justice.

[Drawings—one sheet.]



This is the Sheet of Drawings referred to in the annexed Letters of Registration, granted to Hippolyte Leplax, the eleventh day of July, A. D. 1884.

Augustus Loftus.

(Sig: 245-)



A.D. 1884, 11th July. No. 1457.

IMPROVED MACHINE FOR CUTTING RAGS.

LETTERS OF REGISTRATION to John Currie Johnson, for an Improved Process of, and Machine for, Cutting Rags.

[Registered on the 14th day of July, 1884, in pursuance of the Act 16 Vic. No. 24.]

BY HIS EXCELLENCY THE RIGHT HONORABLE SIR AUGUSTUS WILLIAM FREDERICK SPENCER LOFTUS (commonly called LORD AUGUSTUS LOFTUS), Knight Grand Cross of the Most Honorable Order of the Bath, a Member of Her Majesty's Most Honorable Privy Council, Governor and Commander-in-Chief of the Colony of New South Wales and its Dependencies,

TO ALL TO WHOM THESE PRESENTS SHALL COME, greeting:

WHEREAS JOHN CURRIE JOHNSON, of Yarra Bank, Melbourne, in the Colony of Victoria, engineer, hath by his Petition humbly represented to me that he is the assignee of Fred Pearson, of Melbourne aforesaid, woollen manufacturer, who is the author or designer of a certain invention or improvement in manufactures, that is to say, of an invention entitled "An Improved process of, and Machine for, Cutting Rags," which is more particularly described in the amended specification which is hereto annexed; and that he, the said Petitioner, hath deposited with the Honorable the Treasurer of the said Colony of New South Wales the sum of Twenty Pounds sterling, for defraying the expense of granting these Letters of Registration, as required by the Act of Council, sixteenth Victoria, number twenty-four; and hath humbly prayed that I would be pleased to grant Letters of Registration, whereby the exclusive enjoyment and advantage of the said invention or improvement might be secured to him for a period of fourteen years: And I, being willing to give encouragement to all inventions and improvements in the arts or manufactures which may be for the public good, and having received a report favourable to the prayer of the said petition, from competent persons appointed by me to examine and consider the matters stated therein and to report thereon for my information, am pleased, with the advice of the Executive Council, and in exercise of the power and authority given to me by the said Act of Council, to grant, and do by these Letters of Registration grant unto the said John Currie Johnson, his executors, administrators, and assigns, the exclusive enjoyment and advantage of the said invention or improvement, for and during the term of fourteen years from the date hereof; to have, hold, and exercise unto the said John Currie Johnson, his executors, administrators, and assigns, the exclusive enjoyment and advantage thereof, for and during and unto the full end and term of fourteen years from the date of these presents next and immediately ensuing, and fully to be complete and ended: Provided always, that if the said John Currie Johnson shall not, within three days after the granting of these Letters of Registration, register the same in the proper office in the Supreme Court, at Sydney, in the said Colony of New South Wales, then these Letters of Registration, and all advantages whatsoever hereby granted, shall cease and become void.

In witness whereof, I have hereunto set my sign manual, and have caused the present Letters of Registration to be sealed with the seal of the said Colony of New South Wales, at Government House, Sydney, in New South Wales, this eleventh day of July, in the year of our Lord one thousand eight hundred and eighty-four.

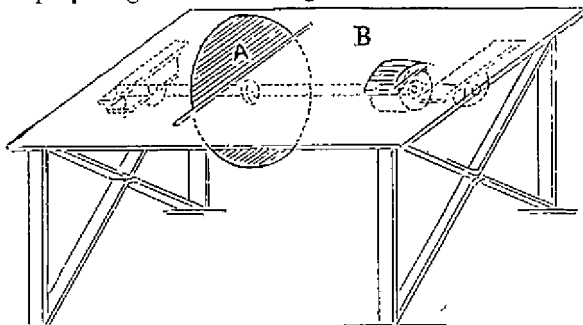
[L.S.]

AUGUSTUS LOFTUS.

An Improved Process of, and Machine for, Cutting Rags.

SPECIFICATION of JOHN CURRIE JOHNSON, of Yarra Bank, in the City of Melbourne, in the Colony of Victoria, engineer, the assignee of FRED. PEARSON, of 146, Flinders-lane West, in the City of Melbourne aforesaid, woollen manufacturer, the inventor of an invention entitled "An Improved Process of, and Machine for, Cutting Rags."

IN preparing old woollen rags, such as coats, trousers, &c., for conversion into shoddy, it is necessary to



separate all the cotton in the seams from the woollen part. This is usually done in one of two ways: either the seams are cut, and the pieces of thread picked out, or the seams are cut entirely away by scissors. Now, this invention has been designed for the purpose of cutting out these seams in a cheaper and more expeditious manner, and consists in the substitution of a revolving disc-knife or cutter for the scissors. This knife I make to project a convenient distance through the centre of a table, and then laying the garment on the table, I guide it against the knife so that it just cuts out the seam quickly

and evenly, leaving the woollen part entirely free from the cotton in the seams. The woollen part is then ready to undergo the needful processes for conversion into shoddy, whilst the seams are useful for being converted into flock.

The sketch in margin represents one of these machines—A being the revolving disc-knife, and B the table.

Having thus described the nature of this invention, and the manner of performing same, I would have it understood that what I claim is—

The improved process of, and machine for, cutting rags, substantially as herein described and explained.

In witness whereof, I, the said John Currie Johnson, have hereto set my hand and seal, this seventh day of April, one thousand eight hundred and eighty-four.

Witness—

EDWD. WATERS, Patent Agent, Melbourne.

JOHN CURRIE JOHNSON.

DISCLAIMER.

To the foregoing specification I wish to add that I would have it understood that I entirely disclaim the use of a circular-saw for any purposes whatever, and that I also disclaim the use of a revolving disc-knife for any other purpose than that of cutting rags—as the invention relates wholly and solely to the cutting of rags.

In witness whereof, I, the said John Currie Johnson, have hereto set my hand and seal.

JOHN CURRIE JOHNSON,
(By his Agent, FRED. WALSH).

This is the amended specification referred to in the annexed Letters of Registration granted to John Currie Johnson, the eleventh day of July, A.D. 1884.

AUGUSTUS LOFTUS.

REPORTS.

Sir,

The application of Mr. J. C. Johnson, for Letters of Registration for an invention entitled "An Improved Process of, and Machine for, Cutting Rags," having been referred to us, we have examined the plan and specification accompanying the same, and have now the honor to report that there is a similar invention in use in this Colony for trimming the edges of stereo plates, which can be seen at the Government Printing Office.

The Under Secretary of Justice.

Sydney, 25 April, 1884.

We have, &c.,
ARCH. FRASER.
THOS. RICHARDS.

Sir,

We have the honor to acknowledge the receipt of Mr. Walsh's letter of the 14th instant, addressed to you, submitted to us for further report under B.C. of 20th instant, and now we beg to state that, upon the amended specification, we see no objection to the issue of Letters of Registration.

The Under Secretary of Justice.

Sydney, 28 May, 1884.

We have, &c.,
ARCH. FRASER.
THOS. RICHARDS.



A.D. 1884, 15th July. No. 1458.

**APPARATUS FOR REDUCING THE TEMPERATURE AND SUPPLYING PURE AIR
WITHIN PUBLIC HALLS, &c.**

LETTERS OF REGISTRATION to Albert Thomas King and John Arthur Grant, for an improved method of, and apparatus for, reducing the temperature and supplying pure air within public halls, churches, schools, dwelling-houses, and other buildings.

[Registered on the 16th day of July, 1884, in pursuance of the Act 16 Vic. No. 24.]

BY HIS EXCELLENCY THE RIGHT HONORABLE SIR AUGUSTUS WILLIAM FREDERICK SPENCER LOFTUS (commonly called LORD AUGUSTUS LOFTUS), Knight Grand Cross of the Most Honorable Order of the Bath, a Member of Her Majesty's Most Honorable Privy Council, Governor and Commander-in-Chief of the Colony of New South Wales and its Dependencies.

TO ALL TO WHOM THESE PRESENTS SHALL COME, greeting :

WHEREAS ALBERT THOMAS KING and JOHN ARTHUR GRANT, both of Sydney, in the Colony of New South Wales, have by their Petition humbly represented to me that they are the authors or designers of a certain invention or improvement in manufactures, that is to say, of an invention entitled "An improved method of, and apparatus for, reducing the temperature and supplying pure air with the public halls, churches, schools, dwelling-houses, and other buildings," which is more particularly described in the specification and the sheet of drawings which are hereunto annexed ; and that they, the said Petitioners, have deposited with the Honorable the Treasurer of the said Colony of New South Wales the sum of Twenty Pounds sterling, for defraying the expense of granting these Letters of Registration, as required by the Act of Council, sixteenth Victoria, number twenty-four ; and have humbly prayed that I would be pleased to grant Letters of Registration, whereby the exclusive enjoyment and advantage of the said invention or improvement might be secured to them for a period of fourteen years : And I, being willing to give encouragement to all inventions and improvements in the arts or manufactures which may be for the public good, and having received a report favourable to the prayer of the said Petition, from competent persons appointed by me to examine and consider the matters stated therein and to report thereon for my information, am pleased, with the advice of the Executive Council, and in exercise of the power and authority given to me by the said Act of Council, to grant, and do by these Letters of Registration grant unto the said Albert Thomas King and John Arthur Grant, their executors, administrators, and assigns, the exclusive enjoyment and advantage of the said invention or improvement, for and during the term of fourteen years from the date hereof ; to have, hold, and exercise unto the said Albert Thomas King and John Arthur Grant, their executors, administrators, and assigns, the exclusive enjoyment and advantage thereof, for and during and unto the full end and term of fourteen years from the date of these presents next and immediately ensuing, and fully to be complete and ended : Provided always, that if the said Albert Thomas King and John Arthur Grant shall not, within three days after the granting of these Letters of Registration, register the same in the proper office in the Supreme Court, at Sydney, in the said Colony of New South Wales, then these Letters of Registration, and all advantages whatsoever hereby granted, shall cease and become void.

In witness whereof, I have hereunto set my sign manual, and have caused the present Letters of Registration to be sealed with the seal of the said Colony of New South Wales, at Government House, Sydney, in New South Wales, this fifteenth day of July, in the year of our Lord one thousand eight hundred and eighty-four.

[L. S.]

AUGUSTUS LOFTUS.

Apparatus for reducing the temperature and supplying pure air within halls, &c.

SPECIFICATION of ALBERT THOMAS KING and JOHN ARTHUR GRANT, both of Sydney, in the Colony of New South Wales, for an invention entitled "An improved method of, and apparatus for, reducing the temperature and supplying pure air within public halls, churches, schools, dwelling-houses, and other buildings."

OUR improved method of reducing the temperature and supplying pure air within buildings, such as public halls, churches, schools, dwelling-houses, workshops, factories, &c., consists in taking air from the open atmosphere at such an elevation where it is or may be supposed to be practically free from impurities, by means of a spray or jet of water under pressure, which at the same time reduces the temperature of such air and forces it into an air-tight chamber or reservoir, in which is an agitator, and from which pipes convey and discharge the cooled pure air at convenient points in the building.

The said spray or jet of water may be at its normal temperature, if such be low enough, or it may be artificially cooled in any approved well-known manner, and it may be supplied from any high-pressure service to the house or building where there is such and its pressure is sufficient, or its pressure may be obtained by pumping to a high level, or by any other well known means. The agitator within the closed chamber or reservoir, and which we call a "water-blast," is a wheel revolved by the water falling from the spray or jet, and it promotes the circulation of the air.

Our improved apparatus consists essentially of a pure air supply-pipe, preferably vertical, having inserted within it a nozzle, pointing downwards, of a water pressure supply-pipe—a closed chamber or reservoir having within it a "water-blast"—and the cooled air distributing-pipes. The pure air supply-pipe reaches above the roofs of buildings or to any other convenient height or place where the air is practically pure, while its other end is inserted in the closed chamber or reservoir. The nozzle turned downwards of the "service" or high-pressure water-pipe is inserted in said pure air supply-pipe at a convenient height such as the pressure of water available will allow. The "water-blast" is a set of revolving vanes, made like an exhaust-fan—on a spindle, between two cheeks bolted to the bottom of the chamber or reservoir.

Any excess above a certain quantity of water in said chamber or reservoir is discharged by a waste-pipe inserted through a water-trap, and the distributing-pipes are led from it to convenient points within the building, and finish, preferably, flush with the floor, being provided with removable nozzles to discharge the air somewhat under pressure. We also prefer that these distributing-pipes should have no sharp angles, and so use "bends," and not L or T unions, for leading around corners, &c.

But, in order that our invention may be clearly understood, we will now describe the same with reference to the drawing hereto attached, which shows sectional elevation of an apparatus constructed according to and for carrying into effect our said invention. A is the pure air supply-pipe; B the water supply-pipe; C the closed chamber or reservoir; D the water-blast; and E the distributing-pipes. A¹ is a revolving cowl or hood which we prefer to use, but which is not an essential feature of our apparatus; B¹ is a nozzle within pipe A of the water supply-pipe B, and B² is a stop-valve or cock; C¹ is waste or discharge pipe; C² is an escape-valve; D¹ are cheeks bolted to bottom of chamber C; D² the spindle; and D³ the vane-wheel or fan; E¹ is socket terminating flush with floor F; and E² is discharging-nozzle, to fit or screw within or upon said socket.

In operation, cock or valve B² being opened, the water in pipe B flows out in a spray or jet from nozzle B¹ and forces or carries down pipe A the pure air entering at A¹, which air in its passage is cooled by contact with the drops or films of said spray or jet, and by the evaporation taking place in said pipe, to or almost to the temperature of the water, and so enters chamber or reservoir C, where it has further contact with the constantly changing body of water therein. The water running and falling down pipe A strikes the vanes of wheel D³ and revolves such wheel, which further agitates the air and water and promotes the circulation and diffusion of the air. A constantly changing body of water remains in the chamber C below the mouth or orifice of discharge-pipe C¹, the excess flowing away through said pipe. The sockets E¹ are provided with ornamental stoppers or corks, which, when it is thought desirable to reduce the temperature or supply pure air at that point, are removed and nozzles E² substituted therefor, when the pure cooled air is distributed somewhat under pressure from such nozzles.

In practice we have found apparatus of the dimensions shown on the drawing. The pure air supply-pipe A reaching to a height of (say) 30 feet above the chamber or reservoir, and the nozzle B¹ inserted (say) 15 feet above the same—work efficiently and reduce the temperature in a building from that of the surrounding atmosphere (say) 90 degrees Fahrenheit to that of the water supplied, namely, the "Yan Yean" service at about 65 degrees Fahrenheit.

Having thus particularly described and ascertained the nature of our said invention, and the manner in which the same is to be performed, we would have it understood that we do not confine ourselves to any particular materials or any particular sizes of or to which our apparatus may be constructed, nor to any particular manner in which the invention may be carried into effect so long as the nature of the same be retained, but what we believe to be novel and original, and therefore claim, is—

First—The improved method of reducing the temperature and supplying pure air within public halls, churches, schools, dwelling-houses, and other buildings, substantially as herein described and explained, and as more particularly set forth in the first paragraph of this specification.

Second—The combination and arrangement of pipe A having water supply nozzle B¹, the closed chamber or reservoir C having within it the water-blast D and the distributing-pipes E, substantially as and for the purposes herein described and explained, and as illustrated in the drawings.

In witness whereof, we, the said Albert Thomas King and John Arthur Grant, have hereto set our hands and seals, this fifteenth day of May, one thousand eight hundred and eighty-four.

Witness—

FRED. WALSH,

Manager, E. Waters' Patent Office, Sydney.

A. T. KING.

J. A. GRANT.

This is the specification referred to in the annexed Letters of Registration granted to Albert Thomas King and John Arthur Grant, the fifteenth day of July, A.D. 1884.

AUGUSTUS LOFTUS.

REPORT.

Apparatus for reducing the temperature and supplying pure air within halls, &c.

REPORT.

Sir,

We do ourselves the honor to report, in reply to your blank cover of the 19th ultimo, No. 5499, transmitting the petition of Messrs. Albert Thomas King and John Arthur Grant, for the registration of an invention entitled "An improved method of, and apparatus for, reducing the temperature and supplying pure air within public halls, churches, schools, dwelling-houses, and other buildings," that we are of opinion the prayer of the petitioners may be granted in terms of their specification, drawings, and claim.

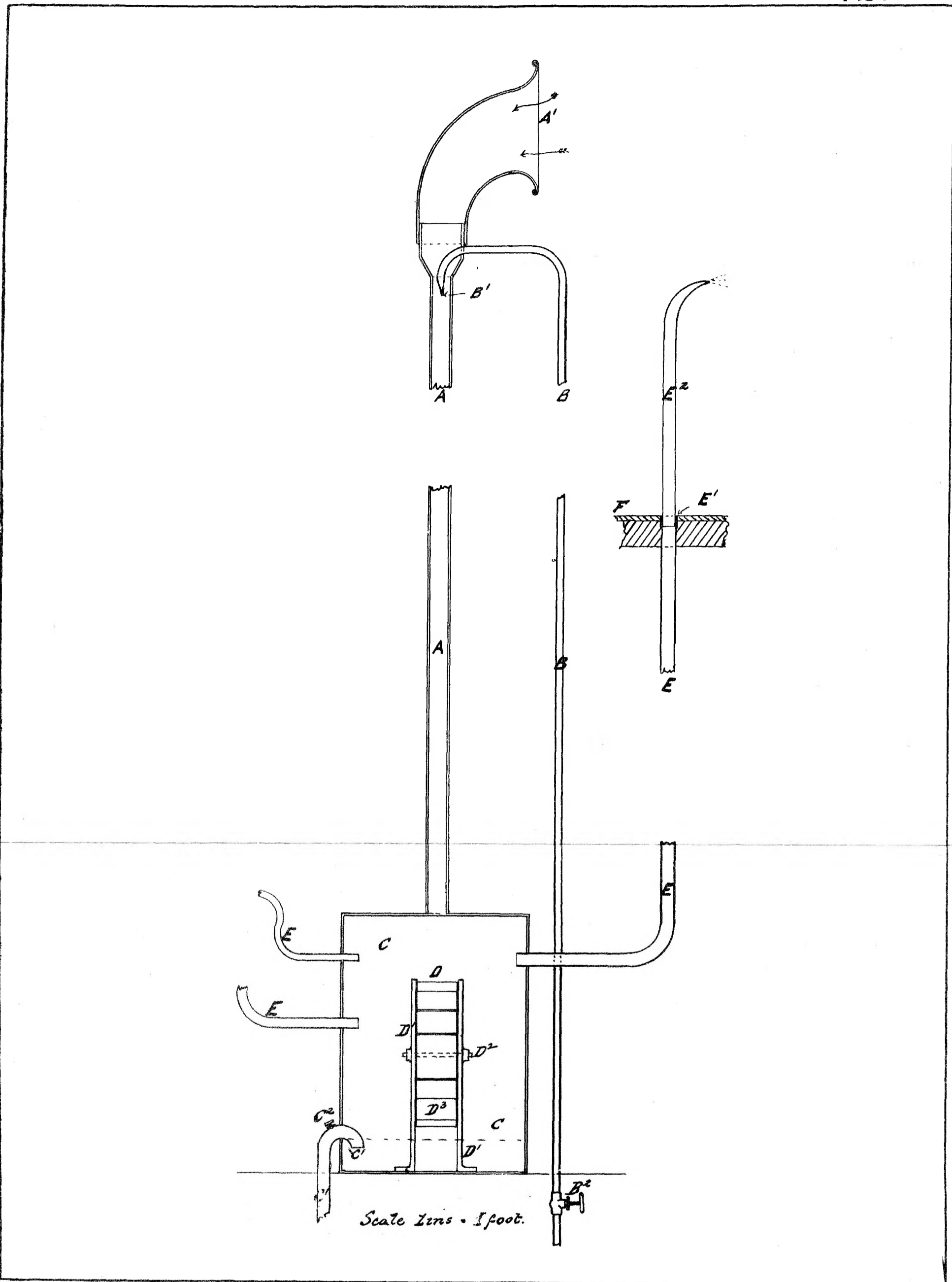
Sydney, 6 June, 1884.

We have, &c.,

E. C. CRACKNELL.
GOTHER K. MANN.

The Under Secretary of Justice.

[Drawings—one sheet.]



(Sig: 245) This is the Sheet of Drawings referred to in the annexed Letters of Registration, granted to Albert Thomas King, and John Arthur Grant, the fifteenth day of July, A. D., 1884. Augustus Loftus.



A.D. 1884, 15th July. No. 1459.

IMPROVED PROCESS FOR COUPLING RAILWAY CARRIAGES.

LETTERS OF REGISTRATION to Franz Kindermann, for an Improved Process for Coupling Railway Carriages.

[Registered on the 17th day of July, 1884, in pursuance of the Act 16 Vic. No. 24.]

BY HIS EXCELLENCY THE RIGHT HONORABLE SIR AUGUSTUS WILLIAM FREDERICK SPENCER LOFTUS (commonly called LORD AUGUSTUS LOFTUS), Knight Grand Cross of the Most Honorable Order of the Bath, a Member of Her Majesty's Most Honorable Privy Council, Governor and Commander-in-Chief of the Colony of New South Wales and its Dependencies.

TO ALL TO WHOM THESE PRESENTS SHALL COME, greeting :

WHEREAS FRANZ KINDERMANN, of Sydney, in the Colony of New South Wales, hath by his Petition humbly represented to me that he is the author or designer of a certain invention or improvement in manufactures, that is to say, of an invention, entitled "Kindermann's Improved Process for Coupling Railway Carriages," which is more particularly described in the amended specification and the sheet of drawings which are hereunto annexed ; and that he, the said Petitioner, hath deposited with the Honorable the Treasurer of the said Colony of New South Wales the sum of Twenty Pounds sterling, for defraying the expense of granting these Letters of Registration, as required by the Act of Council, sixteenth Victoria, number twenty-four ; and hath humbly prayed that I would be pleased to grant Letters of Registration, whereby the exclusive enjoyment and advantage of the said invention or improvement might be secured to him for a period of fourteen years : And I, being willing to give encouragement to all inventions and improvements in the arts or manufactures which may be for the public good, and having received a report favourable to the prayer of the said Petition from competent persons appointed by me to examine and consider the matters stated therein and to report thereon for my information, am pleased, with the advice of the Executive Council, and in exercise of the power and authority given to me by the said Act of Council, to grant, and do by these Letters of Registration grant unto the said Franz Kindermann, his executors, administrators, and assigns, the exclusive enjoyment and advantage of the said invention or improvement, for and during the term of fourteen years from the date hereof ; to have, hold, and exercise unto the said Franz Kindermann, his executors, administrators, and assigns, the exclusive enjoyment and advantage thereof, for and during and unto the full end and term of fourteen years from the date of these presents next and immediately ensuing, and fully to be complete and ended : Provided always, that if the said Franz Kindermann shall not, within three days after the granting of these Letters of Registration, register the same in the proper office in the Supreme Court, at Sydney, in the said Colony of New South Wales, then these Letters of Registration, and all advantages whatsoever hereby granted, shall cease and become void.

In witness whereof, I have hereunto set my sign manual, and have caused the present Letters of Registration to be sealed with the seal of the said Colony of New South Wales, at Government House, Sydney, in New South Wales, this fifteenth day of July, in the year of our Lord one thousand eight hundred and eighty-four.

[J.S.]

AUGUSTUS LOFTUS.

Kindermann's Improved Process for Coupling Railway Carriages.

SPECIFICATION.

Self-couplers of coupling for railway carriages.

THESE self-couplers are to be made on the principle of a hook with a ring, which are hooked together by turning round themselves, and in that way that every part glides over or into the corresponding part of the opposite coupler when the carriages run together. That method or principle of coupling what I beg His Excellency the Governor of the Colony of New South Wales for a patent, or letters of registration, consists, as above-mentioned, in a hook with a ring, but both these things are to be made in one piece, at least, connected like one piece, and in a particular shape or form.

That part *a* of the coupler which performs the nature as a hook for this method of coupling is to be made like a hollow or box, which is open on two sides, marked by *f*. The inside corners of the sides *f* are to be sloped so much that the parts *b* can easily glide into the hollows of part *a*, whether they stand lower or higher than part *a*. Part *b*, which performs the nature as a ring for this method of coupling, is to be made like a square bar, which is to be fastened to part *a*, or both parts could be made of one piece, as the drawing shows. The corners of the sides *f* of part *b* are to be sloped so much that the hollows of parts *a* can easily glide over part *b*. On the sides *g* the couplers are to be connected with the connecting rod by a joint with a pin, as the drawing shows. A shows the couplers before being turned round, B shows the couplers after being turned round, C shows the side of the couplers which I call Klanencouplers. The other parts of the drawing show a mechanism by which the couplers or Klanencouplers could be used without puffers.

It is the method and principle of the above-mentioned Klanencouplers, not only the described shapes or forms of them, what I beg His Excellency the Governor of the Colony of New South Wales for a patent or letters of registration, as the forms or shapes or comparative dimensions of the Klanencouplers could be altered in different (styles) or shapes or forms, but not so the method and principle of the Klanencouplers, as they are turned round the joint of the connecting rod by movement of the carriages, and can be kept in that position, as the drawing shows, for the sake of un-coupling without difficulty.

Sydney, the 4th of May, 1884.

FRANZ KINDERMANN.

This is the amended specification referred to in the annexed Letters of Registration granted to Franz Kindermann, the fifteenth day of July, A.D. 1884.

AUGUSTUS LOFTUS.

REPORT.

Sir,

Sydney, 4 June, 1884.

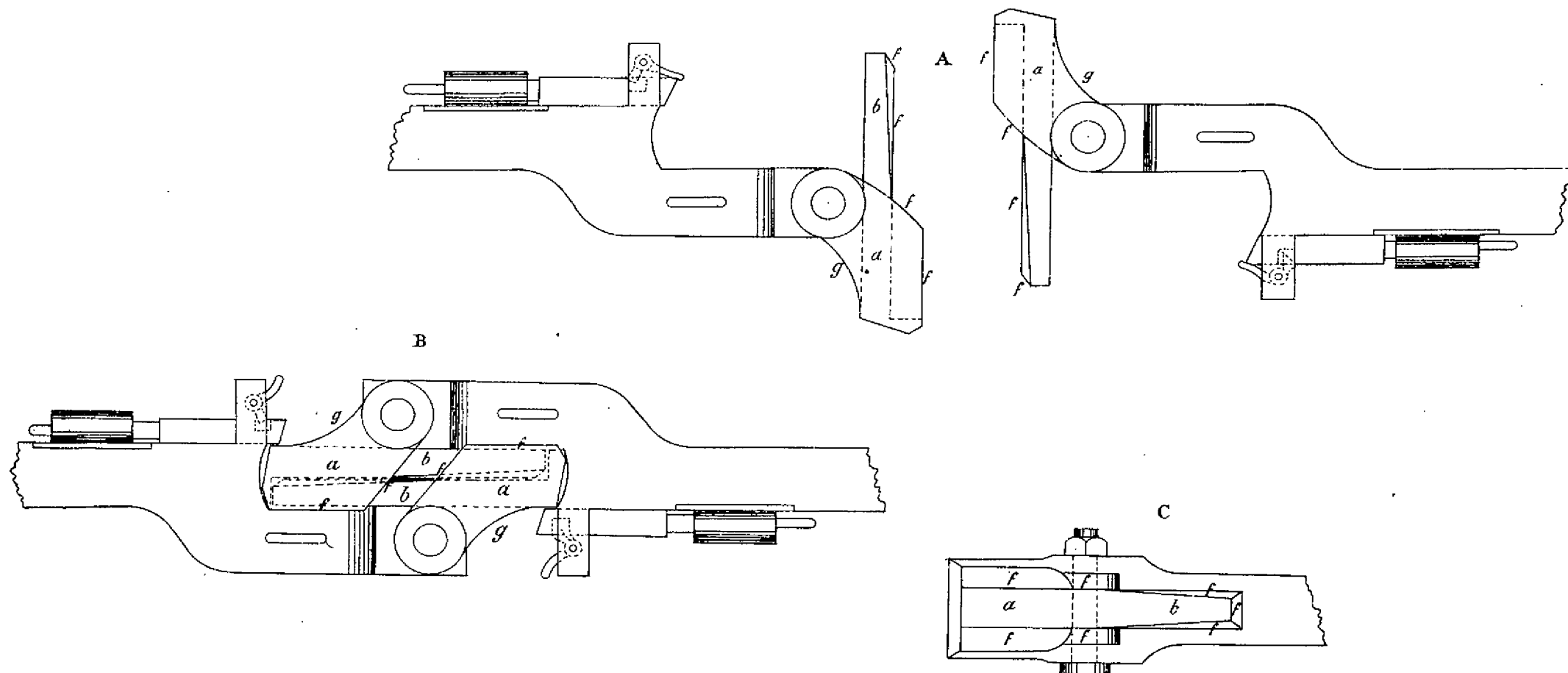
In reference to your B.C. memo. of the 23rd ultimo, covering specification and drawings describing an invention entitled "Coupling for Railway Carriages," for which a petition for letters of registration had been lodged by Mr. Franz Kindermann, of Sydney, under date 7th ultimo, we have the honor to inform you that, having examined the specification and drawings above referred to, we are of opinion that Letters of Registration may be granted, as applied for.

We have, &c.,
JOHN WHITTON.
E. O. MORIARTY.

The Under Secretary of Justice.

{Drawings—one sheet.}

SELF-COUPLING FOR RAILWAY CARRIAGES
BY
FRANZ KINDERMANN.



*This is the Sheet of Drawings referred to in the annexed Letters of Registration,
granted to Franz Kindermann, the fifteenth day of July, A.D., 1884
Augustus Loftus.*



A.D. 1884, 15th July. No. 1460.

IMPROVEMENTS IN THE MAKING OF WHEELS FOR VEHICLES.

LETTERS OF REGISTRATION to Jesse Spring, for Improvements in the making of Wheels for Carriages, Buggies, Drays, Carts, and other vehicles, dispensing with the necessity of cutting and shutting the tires of such Wheels.

[Registered on the 17th day of July, 1884, in pursuance of the Act 16 Vic. No. 24.]

BY HIS EXCELLENCY THE RIGHT HONORABLE SIR AUGUSTUS WILLIAM FREDERICK SPENCER LOFTUS (commonly called LORD AUGUSTUS LOFTUS), Knight Grand Cross of the Most Honorable Order of the Bath, a Member of Her Majesty's Most Honorable Privy Council, Governor and Commander-in-Chief of the Colony of New South Wales and its Dependencies.

TO ALL TO WHOM THESE PRESENTS SHALL COME, greeting :

WHEREAS JESSE SPRING, of Bourke, in the Colony of New South Wales, farmer, hath by his Petition humbly represented to me that he is the author or designer of a certain invention or improvement in manufactures, that is to say, of an invention entitled "Improvements in the making of Wheels for Carriages, Buggies, Drays, Carts, and other vehicles, dispensing with the necessity of cutting and shutting the tires of such wheels," which is more particularly described in the specification and the drawing which are hereunto annexed ; and that he, the said Petitioner, hath deposited with the Honorable the Treasurer of the said Colony of New South Wales the sum of Twenty Pounds sterling, for defraying the expense of granting these Letters of Registration, as required by the Act of Council, sixteenth Victoria, number twenty-four ; and hath humbly prayed that I would be pleased to grant Letters of Registration, whereby the exclusive enjoyment and advantage of the said invention or improvement might be secured to him for a period of fourteen years : And I, being willing to give encouragement to all inventions and improvements in the arts or manufactures which may be for the public good, and having received a report favourable to the prayer of the said Petition, from competent persons appointed by me to examine and consider the matters stated therein and to report thereon for my information, am pleased, with the advice of the Executive Council, and in exercise of the power and authority given to me by the said Act of Council, to grant, and do by these Letters of Registration grant unto the said Jesse Spring, his executors, administrators, and assigns, the exclusive enjoyment and advantage of the said invention or improvement, for and during the term of fourteen years from the date hereof ; to have, hold, and exercise unto the said Jesse Spring, his executors, administrators, and assigns, the exclusive enjoyment and advantage thereof, for and during and unto the full end and term of fourteen years from the date of these presents next and immediately ensuing, and fully to be complete and ended : Provided always, that if the said Jesse Spring shall not, within three days after the granting of these Letters of Registration, register the same in the proper office in the Supreme Court, at Sydney, in the said Colony of New South Wales, then these Letters of Registration, and all advantages whatsoever hereby granted, shall cease and become void.

In witness whereof, I have hereunto set my sign manual, and have caused the present Letters of Registration to be sealed with the seal of the said Colony of New South Wales, at Government House, Sydney, in New South Wales, this fifteenth day of July, in the year of our Lord one thousand eight hundred and eighty-four.

[L. s.]

AUGUSTUS LOFTUS.

Improvements in the making of Wheels for Vehicles.

TO ALL TO WHOM THESE PRESENTS SHALL COME : I, JESSE SPRING, of Bourke, in the Colony of New South Wales, farmer, send greeting :

WHEREAS I, the said Jesse Spring, am desirous of obtaining Letters of Registration for securing unto me Her Majesty's special license that I, my executors, administrators, and assigns, or such others as I or they should at any time agree with, and no others, should or lawfully might from time to time and at all times during the term of fourteen years, to be computed from the day on which this instrument is left at the office of the Colonial Secretary, in Sydney, make, use, exercise, and vend within the Colony of New South Wales, an invention, being "An improved method of making wheels for carriages, buggies, drays, carts, and other vehicles, dispensing with the necessity of cutting and shutting the tires of such wheels." Now know ye, that I, the said Jesse Spring, do hereby declare the nature of the said invention, and in what manner the same is to be used, to be particularly described and ascertained in and by the following statement and specification and drawing thereof.

SPECIFICATION.

THE circumference or circular rim of the wheel consists of two or more wooden felloes banded round by the usual iron or steel tire. These felloes are braced together with a left and right-handed thread thoroughbrace of iron which is bolted in to each felloe. These thoroughbraces are used for the purpose of contracting or expanding the circumference or circular rim of the wheel at pleasure. The junction of the felloes and these thoroughbraces are protected with a sheathing of iron screwed and bolted on to the felloes. The wheel is fitted up with the usual wooden nave banded round with iron. From this nave any number of spokes (12 or 14 preferable) radiate to near the circumference or circular rim of the wheel. The end of each spoke is fitted with an iron, steel, brass, or copper cup, with a cap bolt protruding, which bolt is double wormed. The spokes are fastened to the circumference or circular rim of the wheel by these cap bolts penetrating an iron, steel, brass, or copper cup, or socket fixed and fastened in the felloe. Between the circumference or circular rim of the wheel and the cap of each spoke there is a nut with a double worm, the first of which worms works on the worm of the cap bolt, and the other works on to the cup at the end of each spoke to prevent the first worm moving, and to prevent also any sand or water from penetrating such worm. The spokes are loosened or tightened to the circumference or circular rim of the wheel at pleasure with this nut. The felloes are protected from friction by this nut by a band or clip of iron, steel, brass, or copper fitted and bolted on to such felloes at the junction of each spoke. The nuts and cup and cup-bolt may be of any shape and size, and may be made of iron, steel, brass, copper, or any other suitable material.

The advantages of this invention are the wheels made thereunder are stronger than the usual wooden wheels. The whole circumference or circular rim of the wheel with the tire can be loosened, tightened, or detached at pleasure in a very short time by unscrewing or screwing up each nut at the end of each spoke, and also by loosening or tightening the thoroughbraces. The advantage of this is that the tires of wheels made under this invention need not be cut and shut, but may be tightened by simply screwing up the nuts at the end of each spoke, and by tightening each of the thoroughbraces, and the tires of such wheels may always be put on cold.

The drawings hereunto annexed show a section of a wheel made under this invention, and showing the junction of the felloes and the action of the thoroughbraces, and also showing the end of the spoke with the cup, cap-bolt, and nut as abovementioned.

In witness whereof, I, the said Jesse Spring, have hereunto set my hand, this tenth day of May, in the year of our Lord one thousand eight hundred and eighty-four.

Witness—PHILLIP J. BIDDULPH, solicitor, Bourke.

JESSE SPRING.

This is the specification referred to in the annexed Letters of Registration granted to Jesse Spring, the fifteenth day of July, A.D. 1884.

AUGUSTUS LOFTUS.

REPORT.

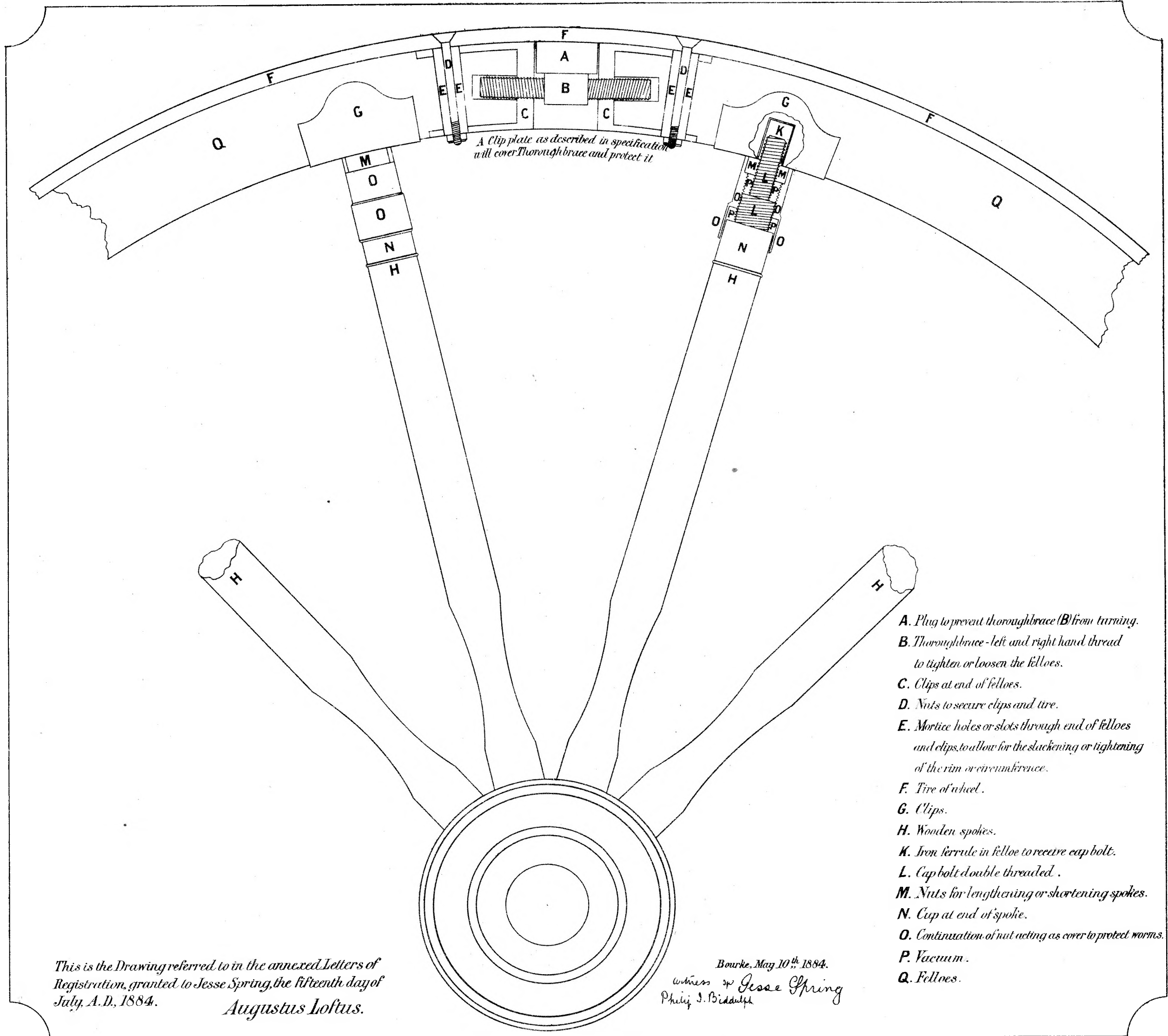
Sir,

Sydney, 4 June, 1884.

We do ourselves the honor to return to you herewith the documents transmitted to us under your B.C. communication of the 29th ultimo, and which have reference to Mr. Jesse Spring's Petition for a grant of Letters of Registration for "An improvement in the Making of Wheels," and we have to report that we see no objection to the issue of the letters asked for, in terms with Mr. Spring's specification, drawing, and claim.

We have, &c.,
JAMES BARNET,
EDMUND FOSBERY.

The Under Secretary of Justice.

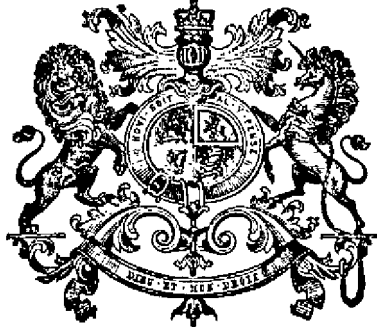


A Clip plate as described in specification will cover Thoroughbrace and protect it

- A. Plug to prevent thoroughbrace (B) from turning.
- B. Thoroughbrace - left and right hand thread to tighten or loosen the fellos.
- C. Clips at end of fellos.
- D. Nuts to secure clips and tire.
- E. Mortice holes or slots through end of fellos and clips, to allow for the slackening or tightening of the rim or circumference.
- F. Tire of wheel.
- G. Clips.
- H. Wooden spokes.
- K. Iron ferrule in felloe to receive cap bolt.
- L. Cap bolt double threaded.
- M. Nuts for lengthening or shortening spokes.
- N. Cup at end of spoke.
- O. Continuation of nut acting as cover to protect worms.
- P. Vacuum.
- Q. Fellos.

This is the Drawing referred to in the annexed Letters of Registration, granted to Jesse Spring, the fifteenth day of July, A.D., 1884.
 Augustus Loftus.

Bourke, May 10th 1884.
 witness of Jesse Spring
 Philip J. Biddulph



A.D. 1884, 15th July. No. 1461.

IMPROVEMENTS IN AMALGAMATORS.

LETTERS OF REGISTRATION to William Edward Barry, for an Improvement in Amalgamators.

[Registered on the 17th day of July, 1884, in pursuance of the Act 16 Vic. No. 24.]

BY HIS EXCELLENCY THE RIGHT HONORABLE SIR AUGUSTUS WILLIAM FREDERICK SPENCER LOFTUS (commonly called LORD AUGUSTUS LOFTUS), Knight Grand Cross of the Most Honorable Order of the Bath, a Member of Her Majesty's Most Honorable Privy Council, Governor and Commander-in-Chief of the Colony of New South Wales and its Dependencies.

TO ALL TO WHOM THESE PRESENTS SHALL COME, greeting :

WHEREAS WILLIAM EDWARD BARRY, of Narrandera, in the Colony of New South Wales, miner, hath by his Petition humbly represented to me that he is the author or designer of a certain invention or improvement in manufactures, that is to say, of an invention entitled "An Improvement in Amalgamators," which is more particularly described in the specification which is herunto annexed; and that he, the said Petitioner, hath deposited with the Honorable the Treasurer of the said Colony of New South Wales the sum of Twenty Pounds sterling, for defraying the expense of granting these Letters of Registration, as required by the Act of Council, sixteenth Victoria, number twenty-four; and hath humbly prayed that I would be pleased to grant Letters of Registration, whereby the exclusive enjoyment and advantage of the said invention or improvement might be secured to him for a period of fourteen years. And I, being willing to give encouragement to all inventions and improvements in the arts or manufactures which may be for the public good, and having received a report favourable to the prayer of the said Petition from competent persons appointed by me to examine and consider the matters stated therein and to report thereon for my information, am pleased, with the advice of the Executive Council, and in exercise of the power and authority given to me by the said Act of Council, to grant, and do by these Letters of Registration grant unto the said William Edward Barry, his executors, administrators, and assigns, the exclusive enjoyment and advantage of the said invention or improvement for and during the term of fourteen years from the date hereof; to have, hold, and exercise unto the said William Edward Barry, his executors, administrators, and assigns, the exclusive enjoyment and advantage thereof, for and during and unto the full end and term of fourteen years from the date of these presents next and immediately ensuing, and fully to be complete and ended: Provided always, that if the said William Edward Barry shall not, within three days after the granting of these Letters of Registration, register the same in the proper office in the Supreme Court, at Sydney, in the said Colony of New South Wales, then these Letters of Registration, and all advantages whatsoever hereby granted, shall cease and become void.

In witness whereof, I have hereunto set my sign manual, and have caused the present Letters of Registration to be sealed with the seal of the said Colony of New South Wales, at Government House, Sydney, in New South Wales, this fifteenth day of July, in the year of our Lord one thousand eight hundred and eighty-four.

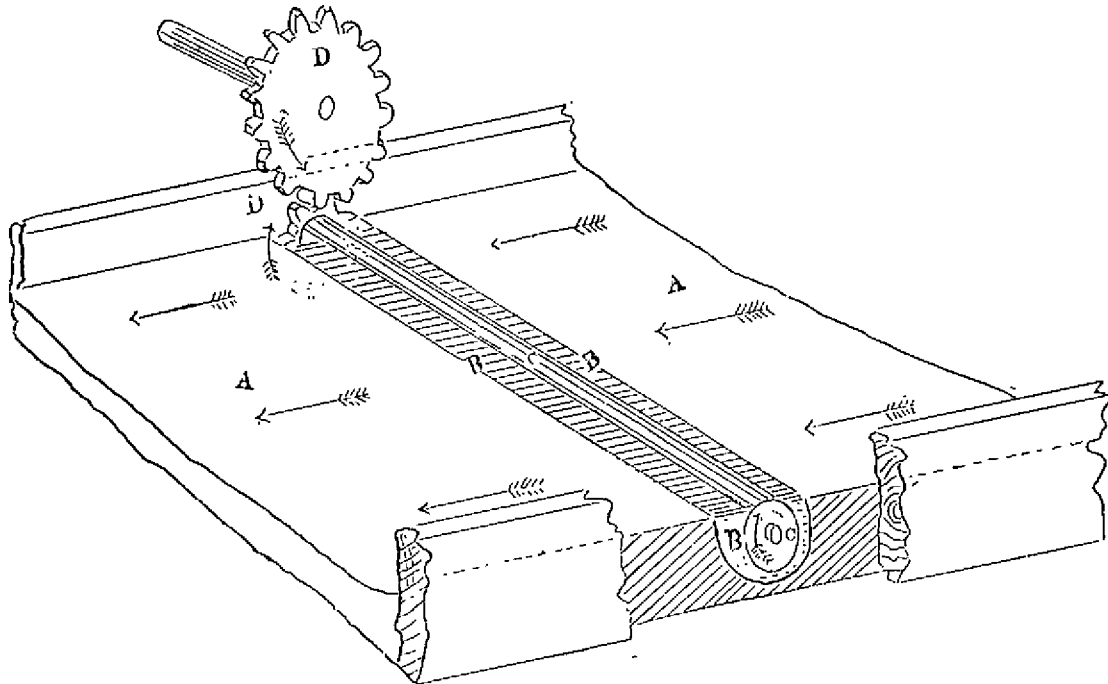
[L.S.]

AUGUSTUS LOFTUS.

Improvements in Amalgamators.

SPECIFICATION of WILLIAM EDWARD BARRY, of Narrandera, in the Colony of New South Wales, miner, for an invention entitled "An Improvement in Amalgamators."

My invention of an improvement in amalgamators consists in the use of a tube or bar having an amalgamable surface revolving in a quicksilver trough or well, in an opposite direction to the flow of the auriferous material, and so fitted as that a small portion of its surface is above the level of the quicksilver. Its operation is to present a constantly renewed quicksilvered surface to the flow of the auriferous material, such surface revolving in an opposite direction to the flow, so as to arrest the gold and carry it back and down into the quicksilver trough or well, where it will deposit itself at once if sufficiently heavy, or where it will ultimately deposit itself if not sufficiently heavy at first, after it has gathered to itself a sufficient number of



other particles of gold to make it heavy enough to fall off the tube or bar; or, if the gold be very fine (and it is so preferred), it may be wiped or scraped off the tube or bar from time to time. It is comparatively immaterial what the bar or tube is made of, so long as it has a quicksilvered surface; and its size, and its height above the quicksilver level, and the speed of its revolution, are all matters to be determined by the operator, although I have found a slow revolution with a solid round bar of copper an inch thick, and projecting one-eighth of an inch above the surface, to act remarkably well.

In the sketch in the margin hereof A is an ordinary copper table; B the quicksilver well or trough; C the tube or bar revolving therein by the operation of the gearing D.

I am aware that iron bars and copper cylinders revolving in quicksilver troughs or wells have been used before, but then they have only just dipped into the quicksilver, and their object and use has been to force the whole of the material under the surface of the quicksilver; whereas my bars do not force the whole of the material under the surface of the quicksilver, but simply gather the gold and carry it under the surface, allowing the bulk of the material to flow over itself as well as the quicksilver. What I believe to be new, and therefore claim as my improvement in amalgamators, is—

The use in quicksilver troughs or wells of a tube or bar having a quicksilvered surface, and revolving slowly in an opposite direction to the flow of the auriferous material, and presenting only a small portion of its surface above the quicksilver, so as to gather the gold to itself and allow the rest of the material to flow over it, substantially as herein described and explained.

In witness whereof, I, the said William Edward Barry, have hereto set my hand and seal, this twenty-eighth day of May, one thousand eight hundred and eighty-four.

W. E. BARRY.

Witness—

EDWARD WATERS, Melbourne, Patent Agent.

This is the specification referred to in the annexed Letters of Registration granted to William Edward Barry, the 15th day of July, A.D. 1884.

AUGUSTUS LOFTUS.

REPORT.

Sir,

The application of Mr. W. E. Barry for Letters of Registration for "An Improvement in Amalgamators" having been referred to us, we have examined the specification accompanying the same, and have now the honor to report that we see no objection to the issue of Letters of Registration, as prayed for.

We have, &c.,

J. SMITH.

A. LEIBIUS.

The Under Secretary of Justice.

Sydney, 7 June, 1884.



A.D. 1884, 15th July. No. 1462.

IMPROVEMENTS IN TELEGRAPH POSTS.

LETTERS OF REGISTRATION to Joseph Oppenheimer for Improvements in Telegraph Posts.

[Registered on the 17th day of July, 1884, in pursuance of Act 16 Vic. No. 24.]

BY HIS EXCELLENCY THE RIGHT HONORABLE SIR AUGUSTUS WILLIAM FREDERICK SPENCER LOFTUS (commonly called LORD AUGUSTUS LOFTUS), Knight Grand Cross of the Most Honorable Order of the Bath, a Member of Her Majesty's Most Honorable Privy Council, Governor and Commander-in-Chief of the Colony of New South Wales and its Dependencies.

TO ALL TO WHOM THESE PRESENTS SHALL COME, greeting :

WHEREAS JOSEPH OPPENHEIMER, of 52, Brown-street, Manchester, in the county of Lancaster, in England, merchant, hath by his Petition humbly represented to me that he is the author or designer of a certain invention or improvement in manufactures, that is to say, of an invention entitled "Improvements in Telegraph Posts," which is more particularly described in the specification and the sheet of drawings which are hereunto annexed; and that he, the said Petitioner, hath deposited with the Honorable the Treasurer of the said Colony of New South Wales the sum of Twenty Pounds sterling, for defraying the expense of granting these Letters of Registration, as required by the Act of Council, sixteenth Victoria, number twenty-four; and hath humbly prayed that I would be pleased to grant Letters of Registration, whereby the exclusive enjoyment and advantage of the said invention or improvement might be secured to him for a period of fourteen years: And I, being willing to give encouragement to all inventions and improvements in the arts or manufactures which may be for the public good, and having received a report favourable to the prayer of the said Petition, from competent persons appointed by me to examine and consider the matters stated therein and to report thereon for my information, am pleased, with the advice of the Executive Council, and in exercise of the power and authority given to me by the said Act of Council, to grant, and do, by these Letters of Registration grant unto the said Joseph Oppenheimer, his executors, administrators, and assigns, the exclusive enjoyment and advantage of the said invention or improvement, for and during the term of fourteen years from the date hereof; to have, hold, and exercise unto the said Joseph Oppenheimer, his executors, administrators, and assigns, the exclusive enjoyment and advantage thereof, for and during and unto the full end and term of fourteen years from the date of these presents next and immediately ensuing, and fully to be complete and ended: Provided always, that if the said Joseph Oppenheimer shall not, within three days after the granting of these Letters of Registration, register the same in the proper office in the Supreme Court, at Sydney, in the said Colony of New South Wales, then these Letters of Registration, and all advantages whatsoever hereby granted, shall cease and become void.

In witness whereof, I have hereunto set my sign manual, and have caused the present Letters of Registration to be sealed with the seal of the said Colony of New South Wales, at Government House, Sydney, in New South Wales, this fifteenth day of July, in the year of our Lord one thousand eight hundred and eighty-four.

[L.S.]

AUGUSTUS LOFTUS.

Improvements in Telegraph Posts.

SPECIFICATION of JOSEPH OPPENHEIMER, of No. 52, Brown-street, in the city of Manchester, in the county of Lancaster, in England, merchant, for an invention entitled "Improvements in Telegraph Posts."

My invention relates to telegraph posts, and consists in forming each of such telegraph posts of a metal tube, or of two or more metal tubes of oval sections, or I construct each of such telegraph posts of a metal tube, or of two or more metal tubes, each of such tubes having flattened sides joined by curved portions.

The said telegraph posts may be formed of one tube of either of the sections abovementioned, which tube may be of the same diameter throughout its entire length, or such tube may taper from the bottom to the top, or the said telegraph post may be formed of two or more tubes of either of the sections abovementioned, and of the same diameter throughout their length, which tubes are secured together by shrinking.

In order that my invention may be better understood and more readily carried into effect, I will now proceed to describe the same, reference being made to the drawing hereunto annexed.

Figure 1 shows one form of a tube which I employ for constructing a telegraph post, which tube is of an oval section, as shown by figure 2, which is a cross section of the said tube taken on the line A B of figure 1. The said tube I form of the largest diameter at its base *a*, and cause such tube to taper towards its upper end *b*. The tube *a b* may be secured in the earth in any convenient manner, and arms or brackets for supporting the telegraph wires may be secured to the post *a b* as usual.

Instead of forming each of the telegraph posts of one tube, I form such telegraph post by joining together two or more metal tubes of different diameters. To effect this I obtain two or more metal tubes made by rolling, drawing, or welding the larger of which I heat and shrink upon the smaller, as is well understood, or I unite the separate tubes forming the telegraph post by a metal socket or other convenient and suitable means.

In the accompanying drawing, figure 3 represents in elevation partly in section a telegraph post constructed according to this modification of my invention. The telegraph post is in this instance formed of three pieces of tube *c d e*, each of which is of an oval section, the tubes *c d e* being united at the joints *f f* being shrunk together as abovementioned.

I strengthen the telegraph post at the joints *f f* by means of rings *f² f³* shrunk thereupon, and I also shrink a ring at the upper extremity of the telegraph post.

Although I have only described and shown the telegraph post as being formed of three tubes, a greater or less number of tubes may be employed as may be found desirable.

In order to support the telegraph posts in the earth I secure to each of such telegraph posts earth plates *g h*, which may be of any convenient and suitable construction.

One of the earth plates is shown in plan in figure 4. Between the earth plate *h* and the tube *c* forming the lower end of the telegraph post I place a strengthening piece or bracket *j*, and I secure the tube *c* to the earth plate *h* by means of the strap *k* and nuts *l*, which bind the whole together. The oval form of the tube *c* enables the tube *c* and earth plate *h* to be more securely bound together than heretofore, such oval form also preventing the tube *c* from being rotated within the strap *k*.

Instead of employing an earth plate of the construction previously described, I in some cases employ a cast iron base of the construction shown by figures 5, 6, 7, figure 6 being a view at right angles to figure 5, and figure 7 being a plan of figure 5. The tube *c* of oval section forming the bottom of the telegraph post I secure into a cavity formed in the cast iron base in either by wedges *n*, the space between which I fill with any suitable cement or any other suitable means, the oval form of the tube *c* preventing such tube from being rotated within the cast-iron base *m*.

To the upper part of the telegraph post I secure the arms *o*, which carry the insulators *p* for supporting the telegraph wires. The arms *o* are secured to the telegraph post by means of bolts *q* and plates *r* as usual. The oval section of the tube *c* prevents the arms *o* from being turned around the telegraph post aforesaid.

In fixing my improved telegraph posts I so place them that the longest diameter of the oval is at right angles to the line of the telegraph wire, as shown in figure 4, in which the longest diameter of the oval is in the direction of the lines C D, and the line of the telegraph wire or wires is in the direction of the line E F.

I have hereinbefore described the tube or tubes, of which each of my improved telegraph posts is formed, as being of an oval section, but I also propose in some cases to make each of such telegraph posts of a tube or tubes, having flattened sides joined by curved portions, as shown in figure 8, which is a section of one of such tubes taken at right angles to the length of such tube.

By my invention I am enabled to form a metal telegraph post of greater strength, in proportion to its weight, than has hitherto been the case, and I am thereby enabled to support a greater number of telegraph wires by one metal telegraph post than has hitherto been possible.

CLAIM.

Constructing a telegraph post of one or more metal tubes, such tube or tubes being of an uniform diameter from end to end, or such tube or tubes may taper from the bottom upwards, such tube or tubes being of an oval section, or of a section the same as or similar to that shown in figure 8, substantially as hereinbefore described and shown.

In witness whereof, I, the said Joseph Oppenheimer, have hereto set my hand and seal, this twenty-ninth day of May one thousand eight hundred and eighty-four.

JOSEPH OPPENHEIMER,

(By his Attorney, JOHN MACDONALD).

Witness—

FRED. WALSH,

Manager, Edwd. Waters' Patent Office, Sydney.

This is the specification referred to in the annexed Letters of Registration granted to Joseph Oppenheimer, the 15th day of July, A.D. 1884.

AUGUSTUS LOFTUS.
REPORT.

Improvements in Telegraph Posts.

REPORT.

Sir, We do ourselves the honor to report, in reply to your blank cover, transmitting Mr. Joseph Oppenheimer's Petition for the registration of an invention entitled "Improvements in Telegraph Posts," that we are of opinion the prayer of the Petitioner may be granted in terms of his specification, drawings, and claim.

Sydney, 6 June, 1884.

We have, &c.,

E. C. CRACKNELL.
GOTHER K. MANN.

The Under Secretary of Justice.

[Drawings—one sheet].

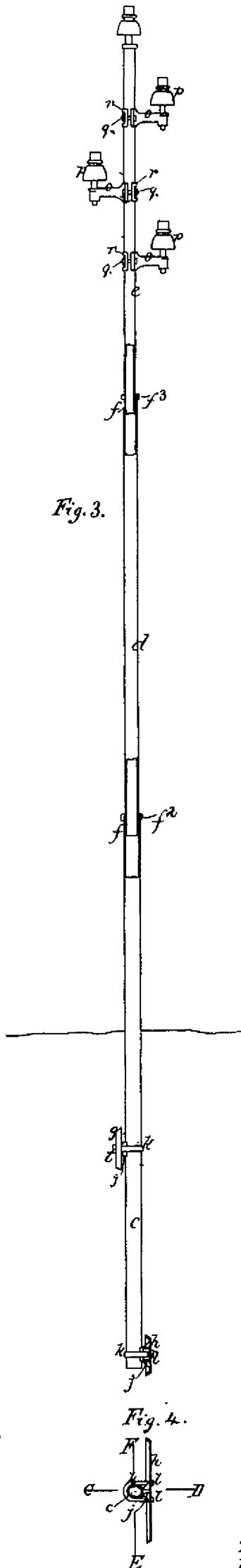


Fig. 3.

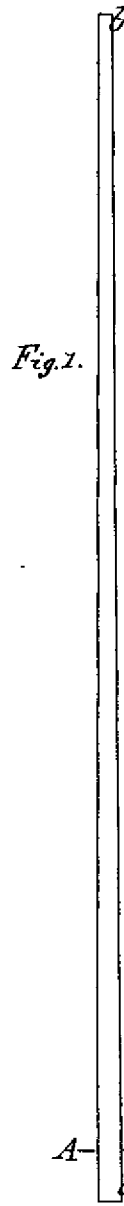


Fig. 1.

Fig. 8.
O

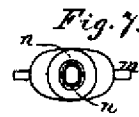


Fig. 7.

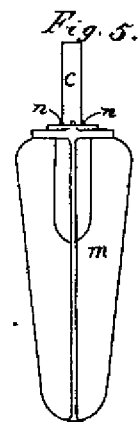


Fig. 5.

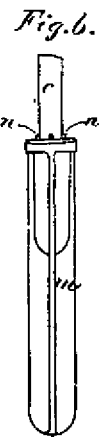


Fig. 6.

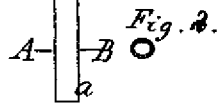


Fig. 2.

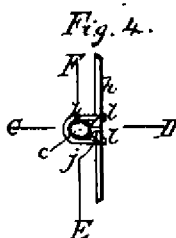


Fig. 4.

This is the Sheet of Drawings referred to in the annexed letters of Registration, granted to Joseph Oppenheimer, the fifteenth day of July, A. D. 1884.

Augustus Loftus.



A.D. 1884, 15th July. No. 1463.

IMPROVEMENTS IN HYDRAULIC ELEVATORS.

LETTERS OF REGISTRATION to Harry Wood Kerle, for Improvements in Hydraulic Elevators.

[Registered on the 17th day of July, 1884, in pursuance of the Act 16 Vic. No. 24.]

BY HIS EXCELLENCY THE RIGHT HONORABLE SIR AUGUSTUS WILLIAM FREDERICK SPENCER LOFTUS (commonly called LORD AUGUSTUS LOFTUS), Knight Grand Cross of the Most Honorable Order of the Bath, a Member of Her Majesty's Most Honorable Privy Council, Governor and Commander-in-Chief of the Colony of New South Wales and its Dependencies.

TO ALL TO WHOM THESE PRESENTS SHALL COME, greeting :

WHEREAS HARRY WOOD KERLE, of No. 141, Pitt-street, Sydney, in the Colony of New South Wales, consulting engineer, hath by his Petition humbly represented to me that he is the author or designer of a certain invention or improvement in manufactures, that is to say, of an invention entitled "Improvements in Hydraulic Elevators," which is more particularly described in the specification, marked A, and the two sheets of drawings, marked B and C respectively, which are hereunto annexed; and that he, the said Petitioner, hath deposited with the Honorable the Treasurer of the said Colony of New South Wales the sum of Twenty Pounds sterling, for defraying the expense of granting these Letters of Registration, as required by the Act of Council, sixteenth Victoria, number twenty-four; and hath humbly prayed that I would be pleased to grant Letters of Registration, whereby the exclusive enjoyment and advantage of the said invention or improvement might be secured to him for a period of fourteen years: And I, being willing to give encouragement to all inventions and improvements in the arts or manufactures which may be for the public good, and having received a report favourable to the prayer of the said Petition, from competent persons appointed by me to examine and consider the matters stated therein and to report thereon for my information, am pleased, with the advice of the Executive Council, and in exercise of the power and authority given to me by the said Act of Council, to grant, and do by these Letters of Registration grant unto the said Harry Wood Kerle, his executors, administrators, and assigns, the exclusive enjoyment and advantage of the said invention or improvement, for and during the term of fourteen years from the date hereof; to have, hold, and exercise unto the said Harry Wood Kerle, his executors, administrators, and assigns, the exclusive enjoyment and advantage thereof, for and during and unto the full end and term of fourteen years from the date of these presents next and immediately ensuing, and fully to be complete and ended: Provided always, that if the said Harry Wood Kerle shall not, within three days after the granting of these Letters of Registration, register the same in the proper office in the Supreme Court, at Sydney, in the said Colony of New South Wales, then these Letters of Registration, and all advantages whatsoever hereby granted, shall cease and become void.

In witness whereof, I have hereunto set my sign manual, and have caused the present Letters of Registration to be sealed with the seal of the said Colony of New South Wales, at Government House, Sydney, in New South Wales, this fifteenth day of July, in the year of our Lord one thousand eight hundred and eighty-four.

[L.S.]

AUGUSTUS LOFTUS.

Improvements in Hydraulic Elevators.

A.

SPECIFICATION of HARRY WOOD KERLE, of No. 141, Pitt-street, Sydney, in the Colony of New South Wales, consulting engineer, for an invention entitled "Improvements in Hydraulic Elevators."

THIS invention relates to that class of hydraulic elevators in which the power is communicated to the load to be lifted through multiplying gear, and which are commonly known as "multiplying" in contradistinction to "direct acting" elevators, and my improvements may be applied to such multiplying elevators, whether they have a vertical, horizontal, or intermedially inclined cylinder. It has been specially devised in order to effect a considerable saving of power, and by it the appliances for carrying or attaching the load may be raised or lowered with but a very small expenditure of power. A load may be lowered with no expenditure of power at all, and in some cases any force generated or produced in excess of the pressure supply, by the lowering of a heavy load, may be stored up or conserved by being admitted to the pressure supply reservoir or accumulator.

My improvements in hydraulic elevators consist, first and essentially, in supplying pressure at the back or lowering side of the ram or piston or upon a piston or pistons in a supplementary cylinder or cylinders to support or overcome the difference of weight of the hoisting chain or cable, and its attachments on either side of the suspending sheave or pulley, whether the excess be on the side of the ram, the counterbalance, &c., or on the side of the appliances for carrying or attaching the load, or *vice versa*.

My improvements in hydraulic elevators consist, secondly, in supplying water, preferably portion of the waste or exhaust water, to the cylinder or cylinders so that said water may enter and fill such cylinder or cylinders behind the ram or pistons ready for the application of pressure or to act as a cushion, and which would otherwise have to be filled from the pressure supply.

They consist, thirdly, in the novel constructions of supply and cut-off valves for simultaneously applying the pressure where needed, and opening the reverse side of ram or the supplementary cylinder or cylinders to the waste or exhaust water supply. They further consist in the novel combinations and arrangements of parts hereinafter particularly set forth.

In one form of my improved multiplying elevators, the pressure to support or overcome the difference of weight of the hoisting chain and attachments, the excess in this case being on the side of the ram the counterbalance, &c., is applied upon an annular piston at the back or lowering side of the ram or piston.

For this purpose the area of said annular piston must be proportioned with reference to the pressure supply.

In another form of my improved multiplying elevators the pressure to support or overcome the difference of weight of the hoisting chain and attachments, the excess in this case being on the side of the carrying or attaching appliances is applied to a ram or rams or piston or pistons in a supplementary cylinder or cylinders, and whose area or united areas are proportional in like manner to that just before described. The supplementary cylinder or cylinders may be arranged with the main cylinder "side by side" or "tandem" fashion, as preferred.

To carry into effect my second improvement, the waste or exhaust water from the cylinder or cylinders is led into a tank or reservoir of a capacity not less than that of the main cylinder or of the united cylinders, and which tank is at a higher level than such cylinders.

My improved valve is a piston valve, that is, a multiple piston works within a cylinder having the necessary openings or ports to main cylinder at its head, and at its foot when the annular piston is used, or to supplementary cylinders when such are used to the pressure supply and to the tank or waste or exhaust reservoir, as hereinafter more fully described.

But in order that my invention may be clearly understood, I will now describe the same with reference to the drawings hereto attached.

Referring to figures 1 to 4.

Figure 1 is a sectional elevation of a multiplying elevator constructed according to my invention, and in which an annular piston at the back of the ram or piston is used to receive the pressure to support or overcome the difference of weight on the hoisting chain and attachments.

Figure 2 is a sectional plan of the same.

Figure 3 is a similar view to figure 1 of a similarly constructed elevator, but the manner of gearing or multiplying is somewhat different.

Figure 4 is a sectional plan of figure 3.

In these two examples the excess of weight is on the side of the ram, the counterbalance, &c., namely, these are somewhat heavier than the carrying or attaching appliances.

A is the cylinder, B the ram or piston, C and D supply ports at head and foot respectively, and E the waste or exhaust water-tank or reservoir. A¹ is inside head of cylinder, and A² is annular space, A³ is stuffing-box and gland, and A⁴ feet or brackets for securing cylinder. B¹ is piston pole or ram, B² annular piston at back, B³ outside guides, C¹ and D¹ are pipes, E¹ is connecting pipe of tank E, and E² overflow branch therefrom.

With special reference to the supply and cut-off valve which, in these two instances, are quadruple piston valves, F is the cylinder or casing, C² and D² supply ports to main cylinder, C³ and D³ exhaust ports to pipe E¹ to tank E, C⁴ and D⁴ are spaces between the two top and bottom pistons respectively, and F space between the top and bottom pair of pistons.

F² pressure supply port, G is hand-wheel, G¹ pinion, G² rack, H piston rod, and H¹, H², H³, H⁴ pistons.

In figures 1 and 2 J is bracket on head of cylinder A, carrying sheaves or loose pulleys J¹ and J², and K is cross-head on end of ram B¹ carrying sheaves or loose pulleys, K¹, K², and K³. The chain or hoisting rope being securely fastened to the cylinder A or to its supports, and reeved round sheaves K¹, J¹, K², J², K³, and round idle sheaves in suitable positions, as is well understood, and fastened to a cage or other means for attaching load.

In

Improvements in Hydraulic Elevators.

In figures 3 and 4, the cross-head K and sheaves K¹ are not attached to the ram, and the stuffing box and gland A³ is at head of cylinder; A⁴ being stuffing box for passage of ram B²; B¹ being rods carrying straps J for one or more sheaves, J¹, the multiplying being performed by means of other idle sheaves, as well understood.

The mode of operation is as follows:—

Suppose a loaded cage to be at the bottom of its travel ready to be raised, and when the cage is in this position the piston B and ram B¹ are as shown in the drawings. Hand-wheel G is now turned so as to bring the pistons H¹, H², H³, H⁴ in position to open the ports, as shown in the drawings, so that the pressure supply will enter port F² and pass through F¹, C², C¹, C to cylinder end A¹, and act on piston B, and raise the load the required height; at the same time there is free communication through D, D¹, D², F below H¹ and D³ from the annular space A² to tank E. To stop the ascent, the pressure supply is cut off by pistons H¹ and H² of the valve, the water remaining in annular space A² being still free; but when load is removed the valve is further moved, when the water is closed therein by pistons H³ and H⁴, and acts as a cushion, the pressure being at the same time relieved from piston B and communication opened to tank E through C, C¹, C², F above H¹ and C³. To lower the empty cage the valve is so placed that pressure enters F², passes through F¹, D², D¹, D to annular space A², and exerts its force on annular piston B², thus supporting or overcoming the excess of weight of the ram, the counterbalance, &c., above that of the cage, and allowing the cage to descend; at this time, end A¹ of the cylinder A is open through C, C¹, C², F above H¹, and C³ to the tank E, into which the waste or exhaust flows. To lift the cage empty it is only necessary to relieve the pressure on the annular piston B². Both ends of cylinder being opened to the tank E the top or head A¹ by C, C¹, C², F above H¹ and C³, and the annular space A² by D, D¹, D², F below H¹ and D³. The weight of the ram and attachments will lift the empty cage or the cage with a load, the united weight of the cage and load not exceeding the proportional weight of said ram and attachments, to the height required. To lower with a load, the pistons of the valve are so placed that both A¹ and A² may be in communication with tank E, or that A¹ may communicate with tank E through C, C¹, C², F above H¹ and C³, and A² with the accumulator by D, D¹, D², F¹, and F².

Referring to figures 5 to 8.

Figure 5 is a sectional elevation of a multiplying elevator constructed according to my invention, and in which rams or pistons in supplementary cylinders receive the pressure necessary to support or overcome the difference of the weight on the hoisting chain and attachments. Figure 6 is a sectional plan of same. Figure 7 is a similar view to figure 5 of a similarly constructed elevator, the manner of gearing or multiplying being somewhat different. Figure 8 is a sectional plan of figure 7. In these two examples the excess of weight is on the side of the carrying and attaching appliances.

A is the main cylinder, and A¹ the main ram or piston. B the supplementary cylinders, and B¹ the supplementary rams or pistons. C is supply port of main cylinder, and D supply ports of supplementary cylinders. E the waste or exhaust water-tank or reservoir. A² are stuffing boxes or glands for rams or piston rods. A³ are feet or brackets for securing cylinders together, and A⁴ the same for securing the whole. C¹ is pipe to supply and cut-off valve from main cylinder A, while D¹ is pipe from the supplementary cylinders to said valve.

With special reference to the supply and cut-off valve, which, in these two instances, are triple piston valves, F is the cylinder or casing, C² is supply port or opening to main cylinder A, and D² supply port to supplementary cylinders B. C³ is exhaust port to pipe E¹ to tank E. D³ is space between two lower pistons, and F¹ space between top piston and bottom pair of pistons. F² pressure supply port; G hand-wheel; G¹ pinion; G² rack; H piston rod; and H¹, H², and H³ pistons.

In figures 5 and 6, J is a bracket on head of cylinder A, carrying sheaves or pulleys J¹ and J²; and K is cross-head on rams A¹ and B¹, carrying loose pulleys K¹, K², and K³, the chain being reeved, as described with reference to figures 1 and 2; while in figures 7 and 8 the glands A² are at head of cylinders, piston rods A² and B² passing through them and carrying straps J for one or more sheaves J¹, the multiplying being performed by idle sheave pulleys in convenient position, as is well understood. L are drain and air pipes.

The mode of operation is as follows:—A load having to be raised (say) in a cage, the valve is so placed by turning hand-wheel G that the pressure will pass through F², F¹, C², C¹, and C into cylinder A¹, and through D², D¹, and D into cylinders B, and be exerted on rams or pistons A¹ and B¹, and raise the load the required height. To lift and empty cage the valve is so placed that the pressure passes through F², F¹, D², D¹, and D into cylinders B and acts upon rams or pistons B¹, and so raises the empty cage or acts as a counterbalance for such, at the same time the valve leaves passage C, C¹, C², F below H³, C³, and E¹ to tank E open so that cylinder A may fill with the water therefrom. To lower the cage, with or without a load, cylinder A is open to tank E through C, C¹, C², F below H³, C³, and E¹, and cylinders B are also open to the same through D, D¹, D², F below H³, C³, and E¹, or when the load is sufficiently heavy cylinders B are open to the pressure supply through D, D¹, D², F¹, and F², the cylinders A¹ being still open to tank E.

It will be seen that the cylinder or cylinders might be in a horizontal instead of a vertical position or intermedially inclined, the only extra requirement being a counterbalance weight in the place of the weight of the ram or piston. Also that the area of the annular piston or of the supplementary rams or pistons, with the given pressure, must be proportional to the excess of weight, and it is not necessary that there be two cylinders, for there might be one or three or more, and such cylinders might be placed "tandem" fashion instead of side by side.

Having thus particularly described and ascertained the nature of my said invention and the manner in which the same is to be performed, I would have it understood that I do not confine myself to any particular manner or means for carrying my invention into effect so long as the nature thereof be retained, but what I believe to be new, and therefore claim as my improvements in hydraulic elevators is:—

First—Supplying pressure to support or overcome the difference of weight in the hoisting chain or cable and attachments on either side of the suspending sheave or pulley, substantially as herein described and explained.

Second—

Improvements in Hydraulic Elevators.

- Second—Filling the cylinders behind the advancing ram or rams, or piston or pistons, from a reservoir of water (preferably the waste or exhaust water) ready for the application of pressure or to act as a cushion, substantially as herein described and explained.
- Third—An annular piston within the main cylinder on the back or lowering side of the ram or piston, substantially as herein described and explained.
- Fourth—The combination with a main ram or piston of one or more supplementary rams or pistons (whether the cylinders be arranged side by side or tandem fashion), substantially as herein described and explained.
- Fifth—The combination and arrangement with the cylinder or cylinders of a tank or reservoir of a capacity not less than the capacity of the cylinder or of the united cylinders at a higher level than said cylinders, substantially as herein described and explained.
- Sixth—The combination and arrangement of parts with or without the supply and cut-off valve, substantially as herein described and explained, and as illustrated in figures 1 and 2 of the drawings.
- Seventh—The combination and arrangements of parts with or without the supply and cut-off valve, substantially as herein described and explained, and as illustrated in figures 3 and 4 of the drawings.
- Eighth—The combination and arrangement of parts with or without the supply and cut-off valve, substantially as herein described and explained, and as illustrated in figures 5 and 6 of the drawings.
- Ninth—The combination and arrangement of parts with or without the supply and cut-off valve, substantially as herein described and explained, and as illustrated in figures 7 and 8 of the drawings.
- Tenth—The special combination and arrangement of parts marked F, C², C³, C⁴, D², D³, D⁴, and F², with the parts marked G, G¹, H, H¹, H², H³, and H⁴, forming my quadruple piston valve, substantially as herein described and explained, and as illustrated in figures 1 to 4 of the drawings.
- Eleventh—The special combination and arrangement of parts marked C², C³, D², D³, F, F¹, and F², with the parts marked G, G¹, G², H, H¹, H², and H³, forming my triple piston valve, substantially as herein described and explained, and as illustrated in figures 5 to 8 of the drawings.
- In witness whereof, I, the said Harry Wood Kerle, have hereto set my hand and seal, this twenty-third day of May, one thousand eight hundred and eighty-four.

HARRY WOOD KERLE.

Witness—

FRED. WALSH,
 Manager, Edwd. Waters' Patent Office, Sydney.

This is the specification marked A referred to in the annexed Letters of Registration granted to Harry Wood Kerle, the fifteenth day of July, A.D. 1884.

AUGUSTUS LOFTUS.

REPORT.

Sir,

Sydney, 2 June, 1884.

We do ourselves the honor to report, in reply to your blank cover of the 27th ultimo, No. 5,695, transmitting Mr. Harry Wood Kerle's petition for the registration of an invention entitled "Improvements in Hydraulic Elevators," that we are of opinion the prayer of his petition may be granted, in terms of his specification, drawings, and claim.

We have, &c.,

H. C. RUSSELL.
 GOTHER K. MANN.

The Under Secretary of Justice.

[Drawings—two sheets.]

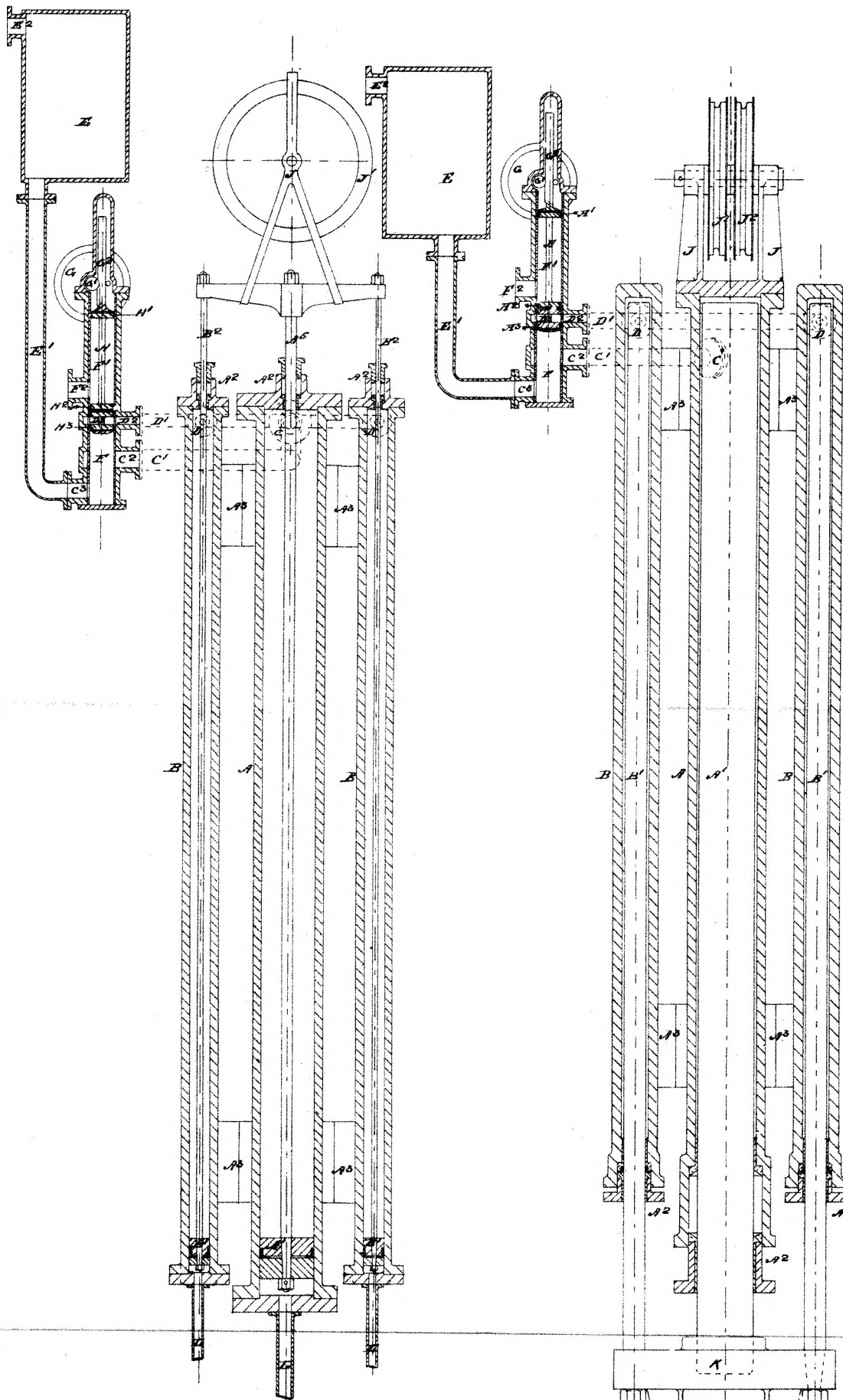


FIG. N° 7

FIG. N° 5

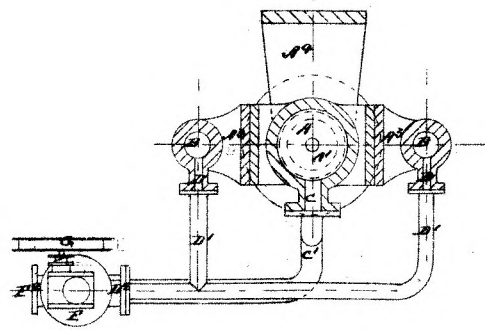


FIG. N° 8

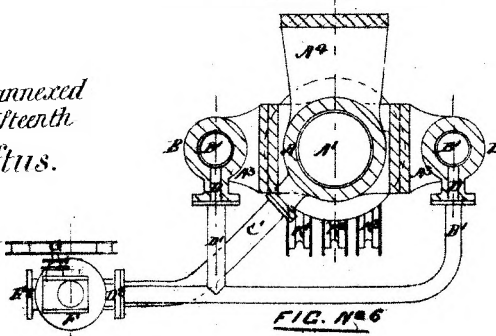


FIG. N° 6

This is the Sheet of Drawings marked C, referred to in the annexed Letters of Registration, granted to Harry Wood Kyrie, the fifteenth day of July, A.D., 1884.

Augustus Loftus.

PHOTO-LITHOGRAPHED AT THE GOVT. PRINTING OFFICE, SYDNEY, NEW SOUTH WALES.

(Sig: 245~)

PHOTO-LITHOGRAPHED AT THE GOVT. PRINTING OFFICE,
SYDNEY, NEW SOUTH WALES.

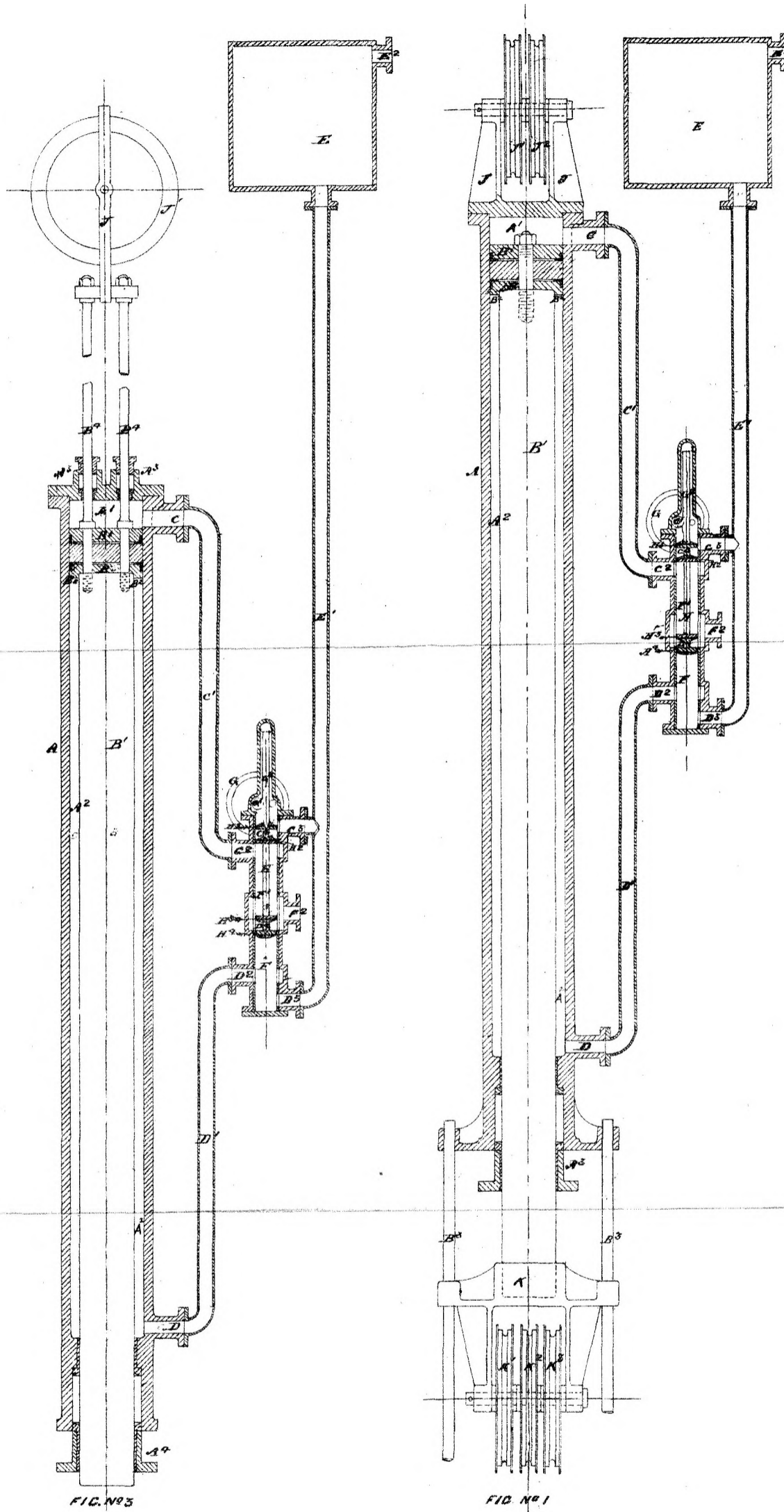


FIG. N°3

FIG. N°1

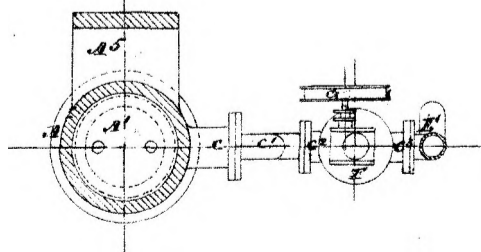


FIG. N°4

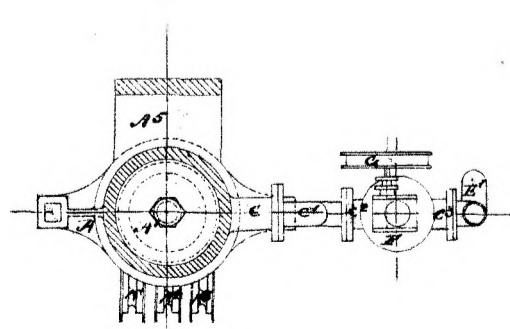


FIG. N°2

(Sig. 245-)

This is the Sheet of Drawings marked B, referred to in the annexed
Letters of Registration, granted to Harry Wood Kerle, the fifteenth day
of July, A. D., 1884.

Augustus Loftus.



A.D. 1884, 17th July. No. 1464.

IMPROVEMENTS IN APPARATUS FOR MAINTAINING TORPEDOES, &c,

LETTERS OF REGISTRATION to Richard Matthews Ruck and Edwyn Jones, for Improvements in Apparatus for maintaining Torpedoes, Submarine Mines, Buoys, Floating Breakwaters, Floating Piers, or other Floating Bodies, at a constant, or nearly constant, depth below the surface of the water.

[Registered on the 17th day of July, 1884, in pursuance of the Act 16 Vic. No. 24.]

BY HIS EXCELLENCY THE RIGHT HONORABLE SIR AUGUSTUS WILLIAM FREDERICK SPENCER LOFTUS (commonly called LORD AUGUSTUS LOFTUS), Knight Grand Cross of the Most Honorable Order of the Bath, a Member of Her Majesty's Most Honorable Privy Council, Governor and Commander-in-Chief of the Colony of New South Wales and its Dependencies.

TO ALL TO WHOM THESE PRESENTS SHALL COME, greeting :

WHEREAS RICHARD MATTHEWS RUCK, of Prospect Row, Chatham, in the county of Kent, England, Captain R.E., and EDWYN JONES, of Woodcote Dower House, Wallington, in the county of Surrey, England, barrister-at-law, have by their Petition humbly represented to me that they are the authors or designers of a certain invention or improvement in manufactures, that is to say, of an invention entitled "Improvements in Apparatus for maintaining Torpedoes, Submarine Mines, Buoys, Floating Breakwaters, Floating Piers, or other Floating Bodies at a constant, or nearly constant, depth below the surface of the water," which is more particularly described in the specification, marked "A," and the two sheets of drawings, marked "B" and "C" respectively, which are hereunto annexed; and that they, the said Petitioners, have deposited with the Honorable the Treasurer of the said Colony of New South Wales the sum of Twenty Pounds sterling for defraying the expense of granting these Letters of Registration, as required by the Act of Council, sixteenth Victoria, number twenty-four; and have humbly prayed that I would be pleased to grant Letters of Registration whereby the exclusive enjoyment and advantage of the said invention or improvement might be secured to them for a period of fourteen years: And I, being willing to give encouragement to all inventions and improvements in the arts or manufactures which may be for the public good, and having received a report favourable to the prayer of the said Petition from competent persons appointed by me to examine and consider the matters stated therein and to report thereon for my information, am pleased, with the advice of the Executive Council, and in exercise of the power and authority given to me by the said Act of Council, to grant, and do by these Letters of Registration grant unto the said Richard Matthews Ruck and Edwyn Jones, their executors, administrators, and assigns, the exclusive enjoyment and advantage of the said invention or improvement, for and during the term of fourteen years from the date hereof; to have, hold, and exercise unto the said Richard Matthews Ruck and Edwyn Jones, their executors, administrators, and assigns, the exclusive enjoyment and advantage thereof, for and during and unto the full end and term of fourteen years from the date of these presents next and immediately ensuing, and fully to be complete and ended: Provided always, that if the said Richard Matthews Ruck and Edwyn Jones shall not, within three days after the granting of these Letters of Registration, register the same in the proper office in the Supreme Court, at Sydney, in the said Colony of New South Wales, then these Letters of Registration, and all advantages whatsoever hereby granted, shall cease and become void.

In witness whereof, I have hereunto set my sign manual, and have caused the present Letters of Registration to be sealed with the seal of the said Colony of New South Wales, at Government House, Sydney, in New South Wales, this fifteenth day of July, in the year of our Lord one thousand eight hundred and eighty-four.

[L.S.]

AUGUSTUS LOFTUS.

SPECIFICATION

Improvements in Apparatus for Maintaining Torpedoes, &c.

SPECIFICATION of RICHARD MATTHEWS RUCK, of Prospect Row, Chatham, in the County of Kent, England, Captain R.E., and EDWYN JONES, of Woodcote Dower House, Wallington, in the County of Surrey, England, barrister-at-law, for an invention entitled "Improvements in Apparatus for maintaining Torpedoes, Submarine Mines, Buoys, Floating Breakwaters, Floating Piers, or other floating bodies, at a constant, or nearly constant, depth below the surface of the water."

THIS invention has for its object improvements in apparatus for maintaining torpedoes, submarine mines, buoys, floating breakwaters, floating piers, or other floating bodies, at a constant, or nearly constant, depth below the surface of the water when the depth of water is increased or decreased either by rise and fall of tide, or by any other means; at the same time giving no indication of the presence of these bodies at or above the surface of the water.

The invention is applicable to—

- (1.) The concealment of floating bodies and explosive charges, when placed under water, in positions where fluctuations of the water level occur.
- (2.) The construction of floating breakwaters and floating piers in similar positions; in such cases the caissons or other floating bodies which support the upper structure can be kept at such a depth below the surface as is required to protect them from wave and wind action; at the same time, the moorings can be maintained "taut," so that the position on plan of the breakwaters or piers will not be altered whilst the water level fluctuates.

The way in which these objects are obtained is as follows (the method is illustrated in the drawings annexed):—

In figs. 1 and 2, A represents the floating body, B is what we term the counterpoise, C is a chain graduated in size and weight, P is a pulley, and S is the anchor or sinker, D is the mooring rope or chain.

The counterpoise B consists of a metal case of suitable size and weight, either open at the bottom or closed by a flexible waterproof diaphragm.

The counterpoise may also consist of a compressible waterproof bag, completely closed and weighted in a suitable manner.

The chain is constructed of a certain number of different sizes and lengths of ordinary metal chain, or it may be specially manufactured to consist of a number of links of different weights; the heaviest part of the chain is at the bottom, and the lightest is next the counterpoise. It is not absolutely necessary that this part of the system should be chain—a weighted rope might do—and it need not pass round the pulley; but the light end would be attached to the counterpoise, whilst the heavy end rested on the ground; in this case the counterpoise would be connected to the floating body A by a mooring rope or chain of uniform size passing round the pulley.

The pulley is made of suitable size and material, and is provided with means of attachment to the anchor or sinker, either by swivel or otherwise; guards are also provided to keep the chain in position whilst passing round the pulley and also to prevent cables from being carried round the block, thus causing it to jamb.

In fig. 1 the floating body is represented in position at the time of low water, whilst in fig. 2 it is shown at the time of high water.

The principle of the invention is as follows:—

Supposing the time to be that of low water, as the water level rises the pressure on the air in the counterpoise increases; more water, therefore, enters through the aperture at the bottom, or, in the case of a collapsing bag, the volume of air becomes smaller, hence the buoyancy of the counterpoise will decrease, and it will sink; as it sinks, however, the chain will pass round the pulley and the floating body will rise. A certain weight of chain will then be suspended from the floating body instead of from the counterpoise, and a new position of equilibrium will then be taken up; another rise of water level will produce a similar result, and thus the floating body will rise as the water level rises. As the water level falls the inverse action takes place, and the floating body falls whilst the counterpoise rises.

By calculating the weights of chain for every foot of rise of water level, the system can be so arranged that the floating body will maintain a constant depth below the surface whilst the water level fluctuates.

In very shallow water the floating bodies can be moored by means of two pulleys, as shown in fig. 3.

In rather deeper water the method of mooring shown in figs. 1 and 2 can be adopted, and in deep water either of the arrangements shown in figs. 4, 5, and 6 can be used.

The mooring rope or chain of the floating body can be made to pass through a ring or rings attached to the counterpoise, in order to prevent any twisting action. This is shown in fig. 7.

Where a cable is attached to the floating body, it can be led away, as shown in figs. 8, 11, and 12.

In fig. 11 a small portion of the cable, near the ground, is wound into a spiral, which acts as a spring, and this allows no slack cable, whilst the buoy it is attached to rises and falls. The cable is a light armoured cable, rendered spiral by winding it upon a bar. The bar is taken out, and a spiral spring cable is the result. In fig. 12 the cable is shown wound spirally round or attached to the mooring rope or chain as far as the pulley, where a spiral is made of sufficient length to allow for the rise of the buoy A.

In some cases it may be desirable to keep the floating bodies at or near the bottom until required at any particular time; this can be done by the methods shown in figs. 9 and 10, where L is a small explosive charge attached to a link in a short length of chain; on exploding the charge the chain is severed. In fig. 10 two sinkers or anchors, S¹ and S², will be required.

It may be desirable in certain cases to employ one counterpoise with a number of floating bodies: One pulley for each buoy, &c., would be required, and one drum or large pulley for the counterpoise.

Instead of using a pulley, a wheel and axle arrangement might be used, or a drum, the ends of the chain and mooring rope being made fast on to the wheel and axle or drum; or the weighted chain may be dispensed with altogether, and a spring used instead, in connection with the pulley, wheel, and axle or drum. In this case the mine and counterpoise would be in connection round the pulley, wheel, and axle or drum by an ordinary mooring rope or chain; as the pulley revolves one way it would compress a spring in connection with it, and on revolving in the opposite direction the compression of the spring would be reduced.

Improvements in Apparatus for Maintaining Torpedoes, &c.

In the case of floating breakwaters and piers, large caissons will have to be used of a size suitable to the work and position; they could be moored as shown in fig. 13.

A wire rope from the caisson passes round each pulley, and is attached to the counterpoise, and the heavy chain rests on the ground; or it may also be arranged, as in the case of the submarine mines, where the chain forms part of the mooring of the buoys or counterpoise.

In the case of a floating breakwater or pier, all the caissons for buoys and counterpoises would be attached together, that is to say, chains or rigid structures would connect all the buoys together, and the same with the counterpoises.

The application of the invention to breakwaters and piers is further illustrated by figs. 14, 15, 16, and 17.

The breakwater or pier will consist of one or more rows of buoys, placed at intervals, as shown in plan by figs. 15, 16, and 17, the number of rows and the intervals at which the buoys are placed being dependent on the size of waves likely to be met with in any position.

The buoys will be constructed of metal or of artificial stone; their size and shape will be somewhat as shown in figs. 18 and 19, but this will be dependent on the size of waves and amount of fluctuation of the water level.

If manufactured of steel or iron, the thickness of the plating will be about $\frac{1}{4}$ " and it will be strengthened by 2 angle and 1 iron ribs and struts rivetted to the plates.

If the buoys are constructed of artificial stone, the thickness of the shell will be about 9".

The buoys will be moored in the manner shown in figs. 14 or 20, which show two alternative methods.

In these drawings the rise and fall of tide is assumed to be 15 feet, and the depth of water at low water to be 60 feet. Two rows of buoys are assumed to be necessary.

The counterpoise cases will be constructed in a similar manner to the buoys, but are cylindrical in shape. There is an aperture about 1 foot in diameter at the base of these cases, and a waterproof bag, folding flat, may be placed inside them; this bag would have an aperture in it, the collar of the aperture being fitted to the aperture of the case, so that water would enter the bag, but not against the sides of counterpoise.

Attached to the counterpoise is a heavy graduated chain, the other end of which rests on the ground; on the counterpoise moving upwards, the weight of a portion of the heavy chain will be borne by the counterpoise, and thus equilibrium will be again established. The chain shown in sketch will weigh about $1\frac{1}{4}$ ton, and will be constructed either of metal or of stone blocks attached to each other by chain or wire rope. Chains or wire ropes will be used to connect the buoy and counterpoise, the rope passing round a pulley, 2 feet diameter, which is attached to a sinker or anchor.

The sinker will be either metal or stone, and, in the example under consideration, will weigh about 10 tons.

The buoys in each row will be connected to each other by girders, as shown in figs. 15 and 16; these girders will be placed below the buoys, so that they will not be influenced by wave action.

Fig. 16 shows the buoys attached by one girder, and in fig. 15 two girders are shown. In the first case (fig. 16), the buoys may be made to pivot round the point of attachment of the girder, in order to present their ends to the waves whatever direction they come from.

The front and rear rows of buoys may be connected together by chains hauled "taut."

Hollow iron cylinders may project from the upper part of the buoys, and on these may be built a pier in the usual manner.

The advantages claimed for these improvements, as far as the same relate to breakwaters and piers, are as follow:—

- (1.) That such breakwaters and piers can be used in places where the water level fluctuates, without the necessity for "slack" mooring chains or ropes at low water; thus the position (on plan) of the structure will remain constant.
- (2.) That the whole of the breakwater, or as much as is thought desirable, can be kept at any depth required below the water level, notwithstanding any fluctuations in this level; thus the structure need not be exposed to wind pressure, and the strain on the moorings will be lessened thereby.

Having now particularly described and ascertained the nature of our said invention, and in what manner the same is to be performed, we declare that what we claim is—

First—The means for maintaining torpedoes, submarine mines, buoys, floating breakwaters, floating piers, or other floating bodies at a constant, or nearly constant, depth below the surface of the water, such means consisting in connecting the floating body with a "counterpoise" and a weighted chain, or like appliance, the said counterpoise being a vessel containing air, which is compressed by the water above the counterpoise, and the connections being such that as the floating body ascends the counterpoise descends, and *vice versa*, and such that the counterpoise, as it descends, becomes progressively more and more relieved from the weight or the downward strain applied by the chain or like appliance, substantially as described.

Second—The several arrangements substantially as represented in the drawings annexed.

In witness whereof, we, the said Richard Matthews Ruck and Edwyn Jones, have hereunto set our hands and seals, this twenty-seventh day of March, one thousand eight hundred and eighty-four.

R. M. RUCK, CAPT. R.E.
EDWYN JONES.

This is the specification marked "A," referred to in the annexed Letters of Registration granted to Richard Matthews Ruck and Edwyn Jones, the fifteenth day of July, A.D. 1884.

AUGUSTUS LOFTUS.

Improvements in Apparatus for Maintaining Torpedoes, &c.

REPORT.

Sir,

We do ourselves the honor to report, in reply to your blank cover of the 19th May, transmitting the petition of Richard Matthews Ruck, Captain R.E., and Edwyn Jones, Barrister, for the Registration of an invention entitled "Improvements in Apparatus for maintaining Torpedoes, Submarine Mines, Buoys, Floating Breakwaters, Floating Piers, or other Floating Bodies at a constant, or nearly constant, depth below the surface of the water," that we are of opinion the prayer of the Petitioners may be granted in terms of their specification, drawings, and claim.

Sydney, 6 June, 1884.

We have, &c.,

E. C. CRACKNELL.
GOTHER K. MANN.

The Under Secretary of Justice.

[Drawings—two sheets.]

Fig. 15.

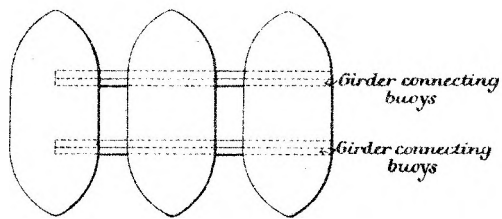


Fig. 17.

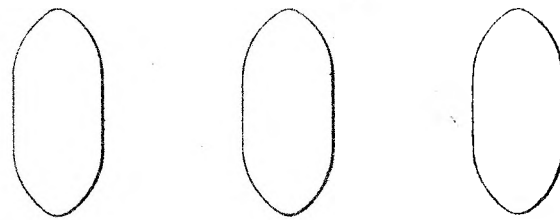


Fig. 18.

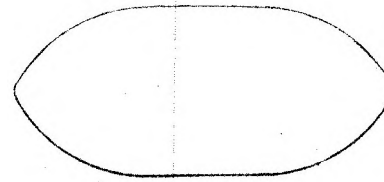


Fig. 16.

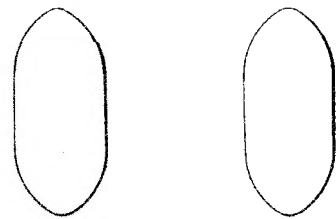
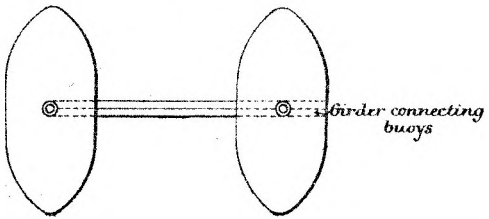


Fig. 19.

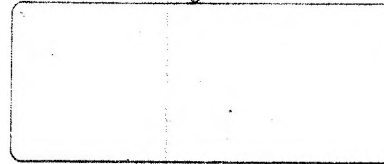
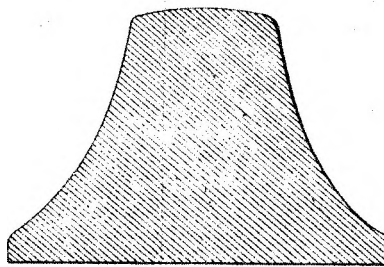
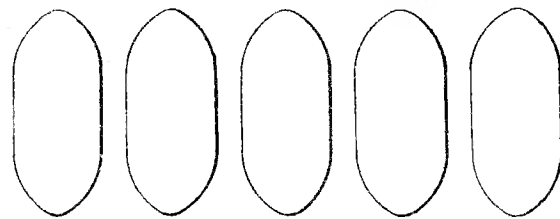
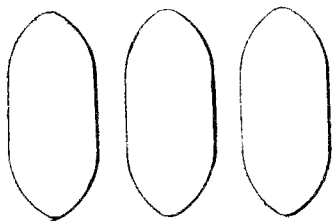
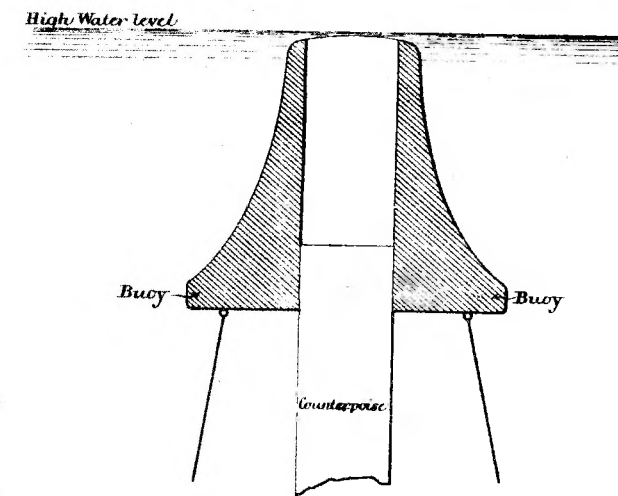
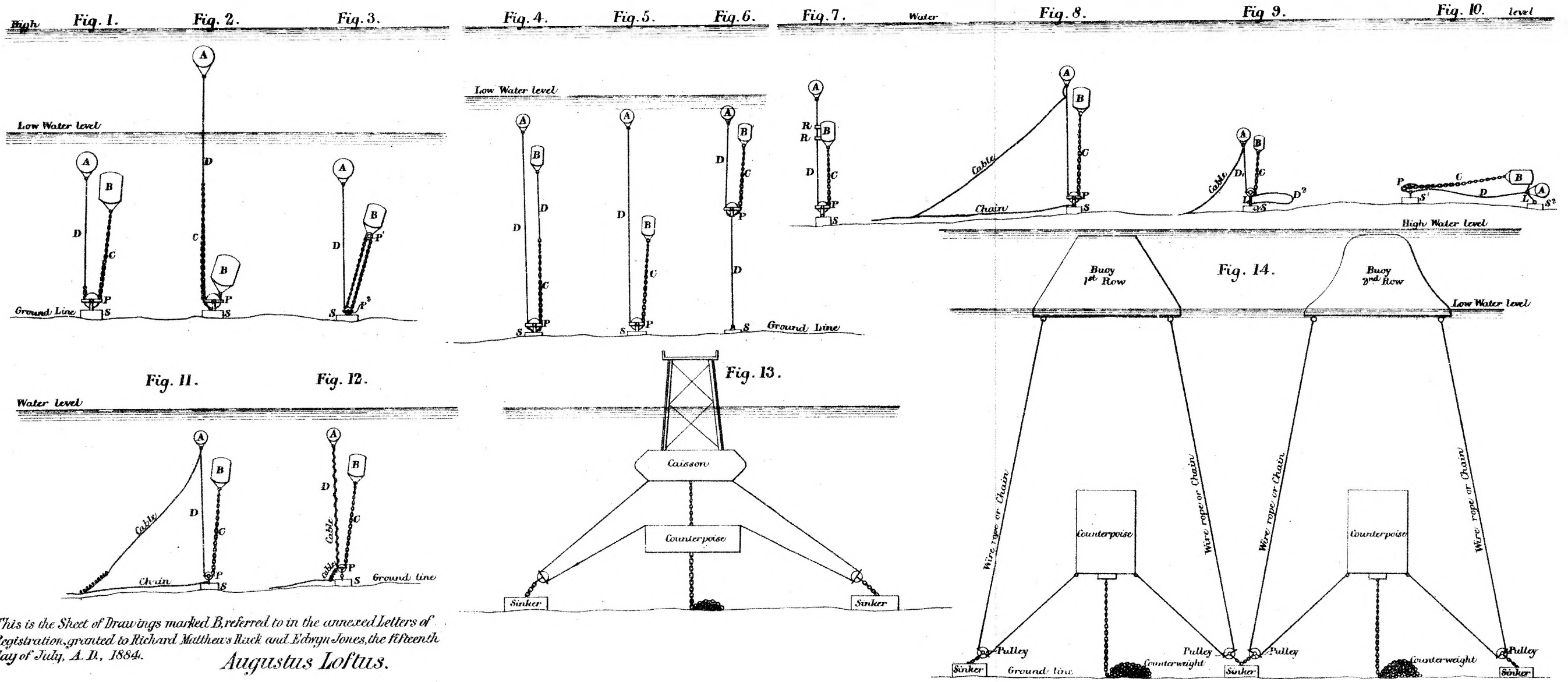


Fig. 20.



This is the Sheet of Drawings marked C, referred to in the annexed Letters of Registration, granted to Richard Matthews Ruck and Edwin Jones, the fifteenth day of July, A. D., 1884. Augustus Loftus.

(Sig: 245-)



This is the Sheet of Drawings marked B, referred to in the annexed Letters of Registration, granted to Richard Matthew's Black and Edwyn Jones, the fifteenth day of July, A. D., 1884.
Augustus Loftus.

(Sig: 245)



A.D. 1884, 16th July. No. 1465.

IMPROVEMENTS IN APPARATUS FOR MEASURING ELECTRICITY.

LETTERS OF REGISTRATION to John Hopkinson, for Improvements in Apparatus for Measuring Electricity.

[Registered on the 18th day of July, 1884, in pursuance of the Act 16 Vic. No. 24.]

BY HIS EXCELLENCY THE RIGHT HONORABLE SIR AUGUSTUS WILLIAM FREDERICK SPENCER LOFTUS (commonly called LORD AUGUSTUS LOFTUS), Knight Grand Cross of the Most Honorable Order of the Bath, a Member of Her Majesty's Most Honorable Privy Council, Governor and Commander-in-Chief of the Colony of New South Wales and its Dependencies.

TO ALL TO WHOM THESE PRESENTS SHALL COME, greeting :

WHEREAS JOHN HOPKINSON, of Victoria-street, in the city of Westminster, England, hath by his Petition humbly represented to me that he is the author or designer of a certain invention or improvement in manufactures, that is to say, of an invention entitled "Improvements in Apparatus for Measuring Electricity," which is more particularly described in the amended specification marked "A," and in the three sheets of drawings marked "B," "C," and "D" respectively, which are hereunto annexed; and that he, the said Petitioner, hath deposited with the Honorable the Treasurer of the said Colony of New South Wales the sum of Twenty Pounds sterling, for defraying the expense of granting these Letters of Registration, as required by the Act of Council, sixteenth Victoria, number twenty-four; and hath humbly prayed that I would be pleased to grant Letters of Registration, whereby the exclusive enjoyment and advantage of the said invention or improvement might be secured to him for a period of fourteen years: And I, being willing to give encouragement to all inventions and improvements in the arts or manufactures which may be for the public good, and having received a report favourable to the prayer of the said Petition from competent persons appointed by me to examine and consider the matters stated therein and to report thereon for my information, am pleased, with the advice of the Executive Council, and in exercise of the power and authority given to me by the said Act of Council, to grant, and do by these Letters of Registration grant unto the said John Hopkinson, his executors, administrators, and assigns, the exclusive enjoyment and advantage of the said invention or improvement, for and during the term of fourteen years from the date hereof; to have, hold, and exercise unto the said John Hopkinson, his executors, administrators, and assigns, the exclusive enjoyment and advantage thereof, for and during and unto the full end and term of fourteen years from the date of these presents next and immediately ensuing, and fully to be complete and ended: Provided always, that if the said John Hopkinson shall not, within three days after the granting of these Letters of Registration, register the same in the proper office in the Supreme Court, at Sydney, in the said Colony of New South Wales, then these Letters of Registration, and all advantages whatsoever hereby granted, shall cease and become void.

In witness whereof, I have hereunto set my sign manual, and have caused the present Letters of Registration to be sealed with the seal of the said Colony of New South Wales, at Government House, Sydney, in New South Wales, this sixteenth day of July, in the year of our Lord one thousand eight hundred and eighty-four.

[L.S.]

AUGUSTUS LOFTUS.

Improvements in Apparatus for Measuring Electricity.

A.

SPECIFICATION of JOHN HOPKINSON, of Victoria-street, in the city of Westminster, England, for an invention entitled "Improvements in Apparatus for Measuring Electricity."

My improvements in apparatus for measuring and recording electricity are as follows:—For this purpose I make use of a centrifugal governor or centrifugal apparatus, and control its velocity by electrical or electro-magnetic apparatus. The centrifugal force of the governor may be opposed by the attraction or repulsion of one conductor conveying electricity on another conductor, conveying electricity of an electro-magnet for its armature, or of a solenoid for its core. Or the centrifugal force may move one contact piece or its equivalent, and the electrical apparatus a second contact piece in suchwise that as the speed of the governor increases the former piece or its equivalent is moved from the second, whilst, as the electrical force increases, the second piece follows up the first. When the centrifugal force is mechanically opposed to the electrical force the governor may act by bringing a friction brake into action, or it may act by making and breaking an electrical contact. The governor may be driven by a small dynamo-electric machine, or, in the case of using a brake, the governor may be driven by clock-work. In order to prevent the force due to the electro-magnet or its equivalent from putting undue pressure on the bearings of the centrifugal governor, I find it advantageous to arrange the electro-magnet symmetrically about the axis of the governor. When the governor and electro-magnet, or its equivalent, carry electrical contact pieces, the ordinary mechanism of the governor may be replaced by a heavy fluid, such as mercury, the surface of the mercury being one of the movable contacts. The electro-magnet, or its equivalent wire, may either carry the whole current to be measured, or may be a shunt, carrying part only of that current. The number of revolutions of the governor may be counted and recorded by clock-work or other suitable mechanism.

Figures 6, 7, 8, and 9 show one arrangement of current-meter constructed according to my invention; fig. 6 being a side elevation; fig. 7 a front elevation; fig. 8 a back elevation, with part in section; and fig. 9 a sectional plan.

a a are the magnets of a small dynamo-electric machine, to be used as a motor; *b* is the armature of the same. This dynamo-electric machine is arranged with fine wire as a shunt to the current to be measured. This derived current passes first round the electro-magnets *a a*, then by the brush *c* to the armature; thence by the brushes *d* and *e* to the insulated ring *f* through the wire *g* (see fig. 8) to an insulated ring, *h*. Here the circuit may be either made or broken according as the movable piece or core *i* is lowered or raised. If this piece be lowered the circuit is thus completed to the metal work of the instrument. *j* is a coil of wire through which the current to be measured passes. It is surrounded by an iron tube *k*, supported by the frame of the instrument. *l* is a shaft driven by the electro-motor carrying an iron core *m*. Fixed to the shaft *n n* are governor balls, which by levers and links *o o* raise or tend to raise the iron core *i*, which revolves with the shaft *l*, and can slide upon it. The revolutions of the shaft *l* are counted by means of the worm and worm-wheel *g*, the pinions and wheels *r*, and the dials *s*. Springs *t* take the weight of the core *i*, and are so adjusted that when no current passes through the coil *j* contact is broken with the insulated ring *h*, but that a very small current through this coil will make the contact and cause the electro-motor to begin to revolve. When a current passes through the coil *j* it causes attraction between the fixed tube *k* and the flanges of the moving cores *m* and *i*; also between the cores *m* and *i*. The magnetic force upon *i* is vertically downwards, and is proportional within limits to the square of the current in the coil. When the governor is revolving the centrifugal force on the governor balls is proportional to the square of the speed of revolution, and tends to lift the core *i* in opposition to the magnetic force. These forces will exactly balance one another, for if the speed be too great the current of the electro-motor will be broken and the speed will fall; if it be too small the electro-motor will work and the speed will increase. The result is that the system will revolve with a velocity proportional to the current through the coil. It will be remarked that owing to the symmetrical arrangement of the cores the electro-magnet forces are balanced so far as the shaft *l* is concerned, and that they do not tend to put any pressure upon the bearings.

Figure 10 shows another arrangement of the controlling mechanism. The coil *j*, tube *k*, and cores *m* and *i*, may be the same as before, so also may be the governor, but as in all the apparatus various forms of governor may be employed. A different form is shown in fig. 10. The system is driven by suitable clock-work, and the speed is controlled by the flange of the core *i* coming in contact when it rises with the brake screws *u u*, instead of by breaking an electric circuit.

Figure 11 shows a modified arrangement of governor and electro-magnet, the object being to get rid of all joints and sliding surfaces of the mechanism. The iron pieces *v v* are suspended by springs *w w*, and are attached in opposition to centrifugal force by the core *i*, which in this case is fixed to the shaft. The circuit of a driving electro-motor is made or broken at *x x*.

Instead of balancing centrifugal force against electro-magnetic force the centrifugal force may move one contact piece or its equivalent and the electrical apparatus a second contact piece, so that as the speed of the governor increases the former is moved from the latter, whilst, as the electrical force increases, the latter follows up the former. This may be done in several ways. One is shown in figures 12 and 13:—*A* is a vertical shaft driven by a suitable electro-motor, and carrying three or more vertical tubes, *B B* and *C*, connected with each other and containing mercury. *D* is a contact piece, making contact with the mercury, unless the mercury is caused to descend in the tube *C* by the action of centrifugal force. *E* is a fixed coil of wire through which the current to be measured passes. *F* is a movable coil, carrying by an arm the contact piece *D*. The current to be measured also passes through *F*. The passage of the current causes the coil *F* to turn on its bearings *G G*, and to depress the contact piece *D* by a distance proportional to the square of the current. The centrifugal force on the other hand depresses the surface of the mercury in the tube *C* to an extent proportional to the square of the speed. The revolutions of shaft *A* may be counted by any suitable mechanism.

In the arrangement, figures 6 to 9, in which an electric contact has frequently to be made and broken, there is a liability to the contingency that the contact may become dirty and require attention.

This

Improvements in Apparatus for Measuring Electricity.

This objection is obviated by the arrangement shown in fig. 14. The piece A is carried by and revolves with that part B of the core of the electro-magnet II which is suspended from the governor, and it makes contact with the bar C, which is insulated and does not revolve. Thus there is always a rubbing when contact is made, which serves to keep the two surfaces clean. The insulated bar C is held up by the spring D.

Other parts of the meter are similar to and act as in the meters hereinbefore described.

When an electricity meter is used for measuring the electricity which passes in one direction as into an electric accumulator, it is sometimes useful to provide that the meter shall automatically deduct the current which flows in the other direction or back from the accumulator when it is discharging. This I effect with meters driven by a small dynamo machine by means of an electro-magnetic switch, which reverses the connection of the shunt to the armature of the small dynamo machine, when the direction of the current changes. Figures 15 and 16 represent in views at right angles to each other (the latter with one arm of the lever in section) a suitable arrangement of magnetic switch for carrying this part of my invention into effect; and fig. 17 is a diagram showing the connections to the meter. A² is a counter-balanced three-arm lever. The arm a¹ carries a solenoid core a² wound with fine wire as a shunt connecting the two poles of the accumulator. B¹ is a solenoid for the said core, the said solenoid being in the main circuit, in which also the solenoid of the meter is situated. The arms a² and a³ of the lever A² are provided each with a contact piece insulated from the arms of the lever. The said contact pieces can make contact with the springs so connecting A with B, and G with H, or B with C, and F with G. When the current in the main (and consequently through the solenoid B¹) is running in one direction, the core a² is drawn into the said solenoid, and the contacts at B C and F G are made, causing the armature of the small dynamo to run in one direction, but when the current in the main flows in the reverse direction the core B is repelled, and the contacts at A B and G H are made, thereby reversing the motions of the said armature.

In the diagram, fig. 17, *i* represents the shunt leading to the armature *j* of the small dynamo machine, and to the magnets *k* of the meter dynamo. The contacts of the solenoid B¹ are indicated at *b*, and the solenoid of the meter is indicated at *k*²; *l* indicates the main circuit; *i*² the contact breaker on the shunt *i*; and D E, in figures 15 and 17, show the terminals for the shunt to the core a² of the solenoid B¹; the other parts indicated in the diagram, fig. 17, are marked with letters of reference like those used to indicate corresponding parts in fig. 15. It is useful with accumulators to arrange that the meter should give a signal or disconnect the circuit when the accumulator has received a predetermined charge. This I may effect by means of the counting mechanism shown in figures 6, 7, and 9, operating an alarm exactly as in ordinary clock-work, or by causing the counting mechanism to make or break an electric contact in circuit with a simple electro-magnet, which shall operate apparatus to give the signal or break the circuit to the accumulator.

It is important to provide cut-outs to disconnect automatically the conductor to any consumer if the current passing be too great, or if there be an "earth" on the premises when the current is used, or in some cases if the potential be too great. A convenient arrangement for this purpose is shown in fig. 18. *a a* are mercury cups into which the bridges *b* dip to give electric continuity with the line wires *c*, which also dip into the said cups. The wire *c* leading the current to the place of consumption is wound around the core *d*, so as to constitute it an electro-magnet, the armature of which is one end of the lever *e*, which rests upon the knife edge *f*, and is capable of adjustment by a screw *g*. Upon the knife edge *f* also rests a lever *h*, one arm resting by means of an adjusting screw *h*² upon the lever *e*, the other arm being counter-weighted so as to be nearly in unstable equilibrium. *i* is a connection attaching the bridges *b* to the lever *e*. Thus when too strong a current passes through the line the core *d* attracts the lever *e*, the other end of which cants up, displacing the counter-weight of the lever *h* to the other side of the vertical line, so that the said lever falls over and smartly pulls up the bridges *b* from the cups *a*, and so breaks the circuits of the wires *c*.

When it is desired to break the circuit, if there be an "earth" on the consumer's premises, the magnet *d* is wound with two sets of coils, one for the entering current, and one for the returning current, arranged in opposition to each other, but in each set the number of convolutions on the two limbs of the magnet core are unequal. If then there be no "earth" on the circuit, the effect of the current will be to produce either two feeble north, or two feeble south poles, which will not move the armature of the switch, whereas a feeble current, either in the entering or in the returning wire, will produce an ordinary horseshoe magnet powerfully attracting the armature, and thus will operate the switch to break the circuit.

My improvements further relate principally to maintaining the electro-motive force in a system of conductors for an electric supply at a fixed potential, but this part of the invention also relates to reducing the cost of such conductors consistently with efficiency and safety, to arrangements for disconnecting the dynamo machines from the conductors, and to improvements in the instruments for measuring the quantity of electricity sent into or drawn from the system of conductors. When electricity is delivered by means of a pair of conductors to a distance from the station where the electricity is generated there is a fall of potential due to the resistance of such conductors, greater as the current is greater; and if it be desired to maintain the potential constant at the delivery end, it is necessary to increase the potential at the supply end, as the current increases in a suitable manner. To ascertain the potential at the far end of the conductor I make use of a galvanometer, differentially wound with two coils, the one coil having a high resistance as for measuring potential, and the other coil of very low resistance conveys the current to the main conductor, and acts in opposition to the high resistance coil. The differential coils may be wound on an electro-magnet, which acts as a relay to ring an electric bell, or to set in motion or reverse a small dynamo machine to adjust resistance or control the speed of the steam-engine for the purpose of keeping the potential on service main conductors constant. An approximation to the same end may be attained by winding on the electro-magnets of the dynamo machines, in addition to the usual coils, whether in shunt or conveying a current from a separate exciter, a few coils conveying the current to the main conductor, the effect of such coils being suitably adjusted. These latter coils may be wound on a separate electro-magnet.

Having now described and particularly ascertained the nature of my said invention, and the manner in which the same is or may be used or carried into effect, I would observe in conclusion that what I consider to be novel and original, and therefore claim as my invention is—

First—

Improvements in Apparatus for Measuring Electricity.

- First—In an electric measuring apparatus, the use of a centrifugal governor, the speed of which is electro-magnetically controlled, substantially as hereinbefore described.
- Second—In an electric measuring apparatus, the use of a centrifugal governor, in which the centrifugal force is mechanically opposed by the attraction or repulsion of an electro-magnet, or of one conducting wire for another conducting wire, substantially as hereinbefore described.
- Third—In an electric measuring apparatus, the combination of the centrifugal governor and a dynamo-electric machine, the circuit of which is opened or closed by the action of the governor, substantially as hereinbefore described.
- Fourth—In an electric measuring apparatus, the arrangement of magnet and governor for the purpose of avoiding pressure on the bearing, substantially as hereinbefore described.
- Fifth—In an electric measuring apparatus, the use of a mercurial or other fluid governor in combination with an electro-magnetic arrangement, substantially as hereinbefore described with reference to figures 12 and 13 of the accompanying drawings.
- Sixth—The improvements in the said current meter, consisting in providing the meter with a rubbing contact at the part where the circuit of the motor of the meter is broken, substantially as and for the purpose hereinbefore described with reference to fig. 14 of the accompanying drawings.
- Seventh—In combination with meters for measuring electricity, the use of means for automatically deducting from the record or indication of the current passing in one direction, the quantity of current which passes in the other direction, substantially as hereinbefore described with reference to figures 15, 16, and 17 of the accompanying drawings.
- Eighth—The switch arranged and operating substantially as and for the purpose hereinbefore described with reference to figures 15, 16, and 17 of the accompanying drawings.
- Tenth—The arrangement and combination of parts constituting the "cut-out," substantially as hereinbefore described and illustrated in fig. 18 of the accompanying drawings.
- Eleventh—In electric "cut-outs," the employment of a tumbling-piece, arranged and operating substantially as and for the purpose hereinbefore described with reference to the piece *h* in fig. 18.
- Twelfth—In "cut-outs," the combination with a switch (such as illustrated in fig. 18 or any other suitable switch or contact-breaker) of an electro-magnet wound with two sets of coils, one for the entering, and one for the returning current, substantially as and for the purpose hereinbefore described.

This is the amended specification marked "A," referred to in the annexed Letters of Registration, granted to John Hopkinson, the sixteenth day of July, A.D. 1884.

AUGUSTUS LOFTUS.

REPORTS.

Sir,

Sydney, 18 December, 1883.

We do ourselves the honor to reply to your blank cover, 4th instant, that the petition of John Hopkinson, for the registration of "Improvements in and Apparatus for Generating, Distributing, Measuring, Recording, Controlling, and Utilizing Supply of Electricity" involves four distinct matters, which may be classified under the following headings, viz. :—

1. Improvements in dynamo-electric machines as set forth in specification and drawings, figures 1 to 5 inclusive, and first claim.
2. An improved centrifugal governor or apparatus, and modified arrangements of governor, figures 6 to 14 inclusive, with the second and third claims.
3. Improvement in electric meters, figures 15 to 18, and claims fourth to the thirteenth inclusive.
4. Improvements in distributors, main conductors, and lamp systems, figures 19 to 27, and claims fourteen to sixteen inclusive.

As the combination of essentially different matters under the one and the same petition and specification would lead to material inconvenience and confusion in the recorded detail of invention, and, moreover, is not in accordance with the letter of the Act, we are unable to recommend the prayer of the petitioner in its present form, and suggest that the papers in question be returned for subdivision and revision.

We have, &c.,

E. C. CRACKNELL.
GOTHEK K. MANN.

The Under Secretary of Justice.

Sir,

Sydney, 8 May, 1884.

In returning to you Mr. John Hopkinson's revised application for Letters of Registration, transmitted for our further report, under your blank cover of the 19th ultimo, we do ourselves the honor to state that as Mr. Hopkinson has now submitted a modified specification, comprising "Improvements in Apparatus for Measuring Electricity" only, we are of opinion the prayer of the petitioner may now be granted in accordance with the said revised specification, but with the exception of the ninth claim thereof.

We have, &c.,

E. C. CRACKNELL.
GOTHEK K. MANN.

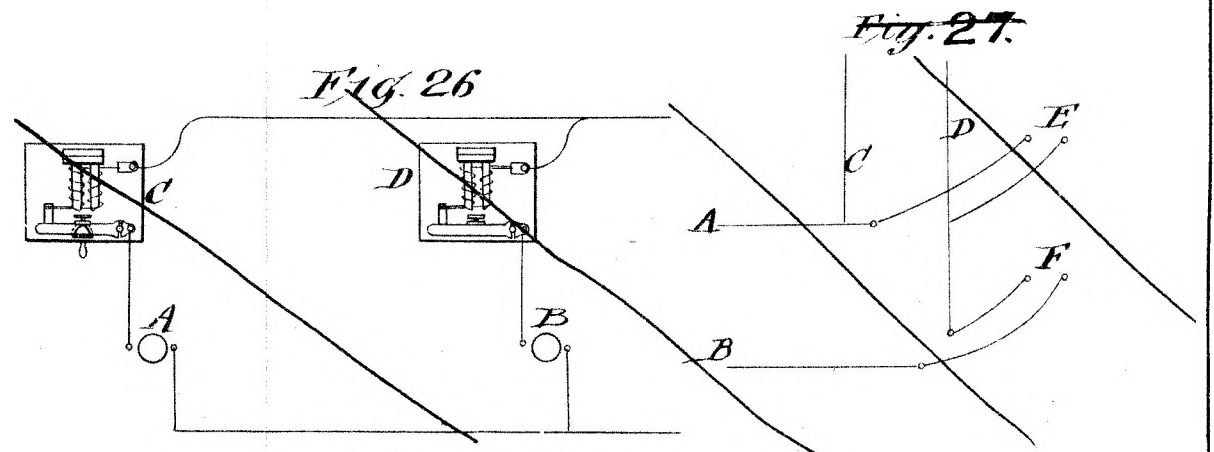
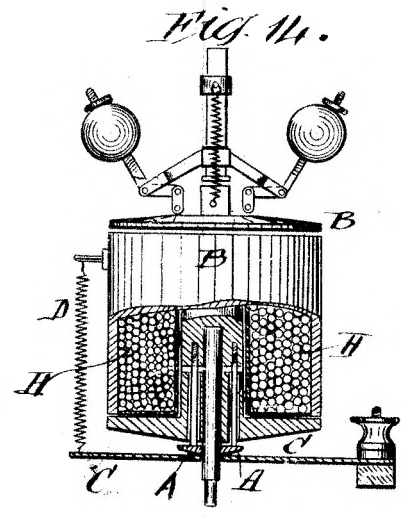
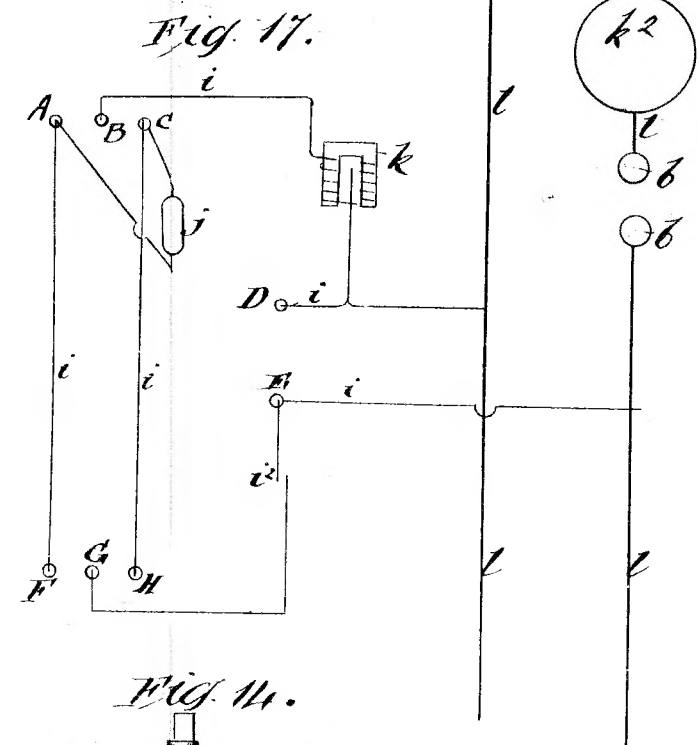
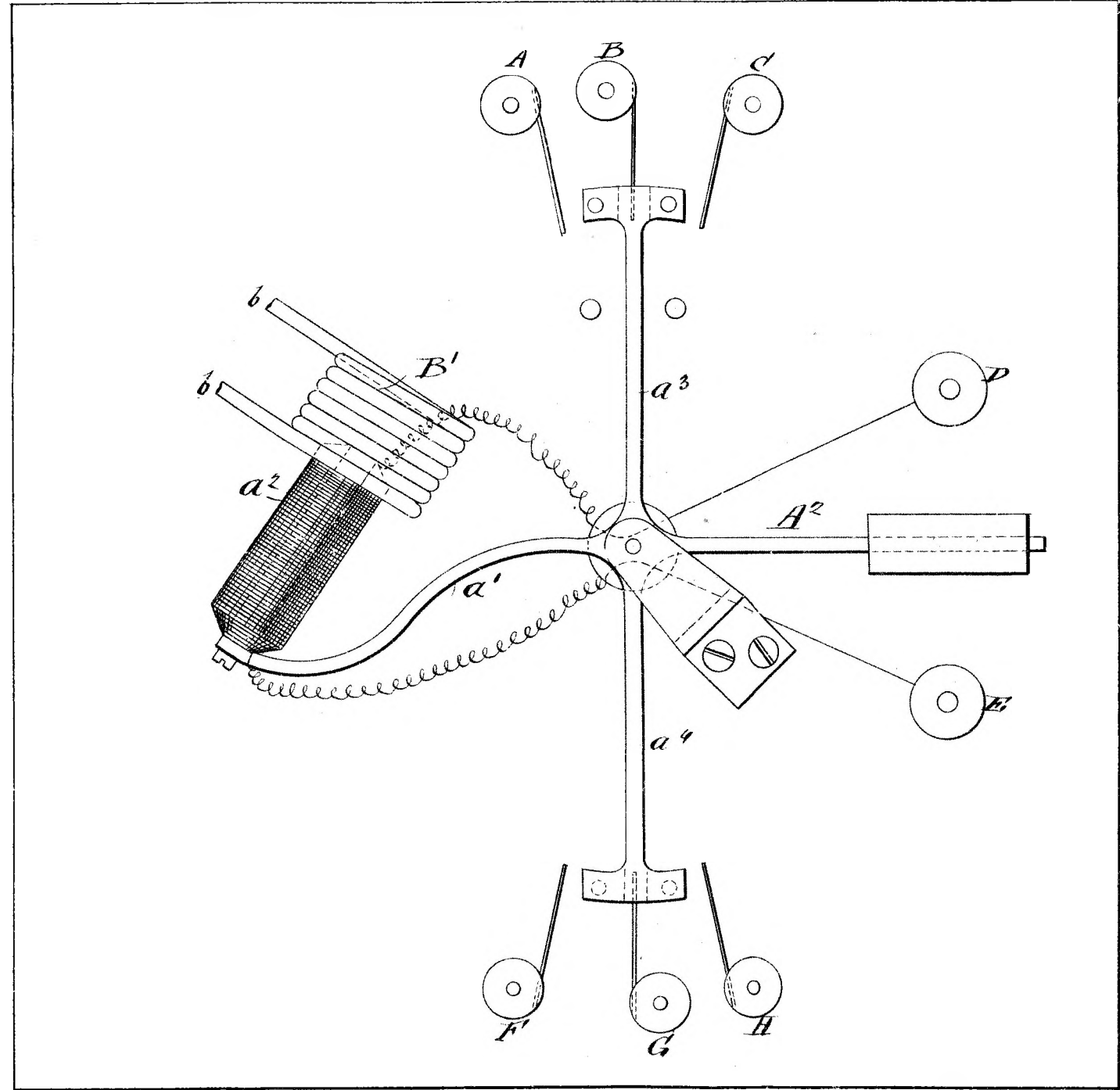
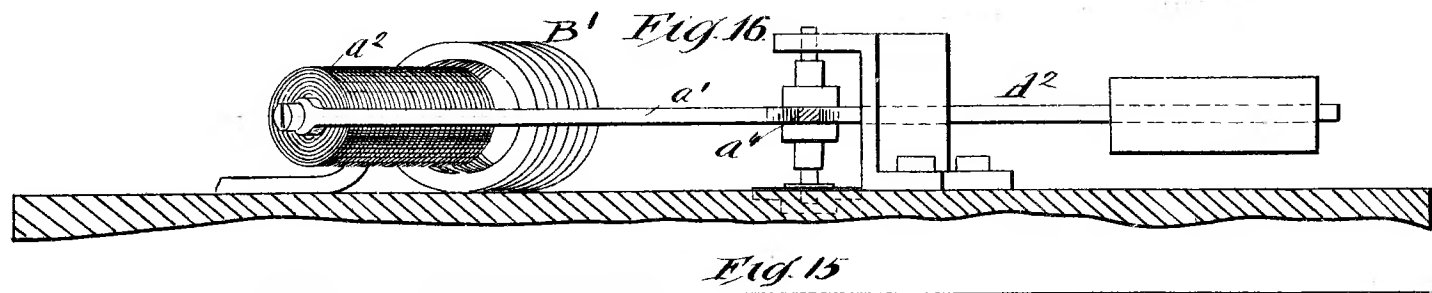
The Under Secretary of Justice.

Memo.—The claim having been amended by the omission of the ninth clause, the Board find no further objection to the issue of the letters of registration.

5th June, 1884.

E. C. C.
G. K. M.

[Drawings—three sheets.]

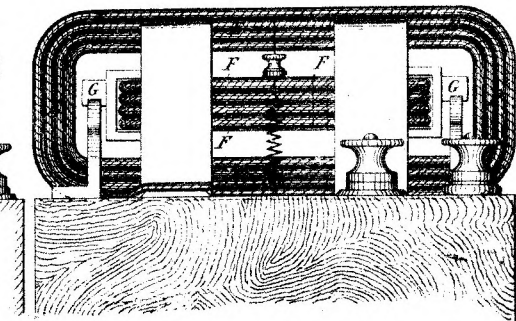
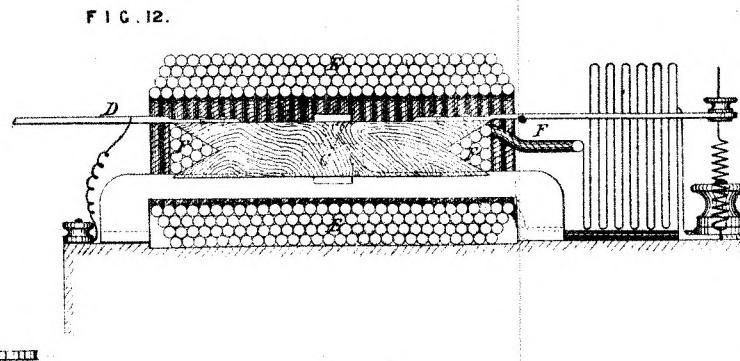
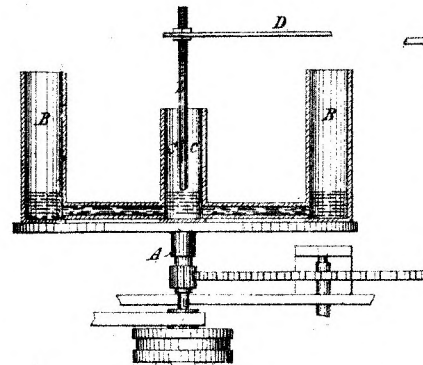
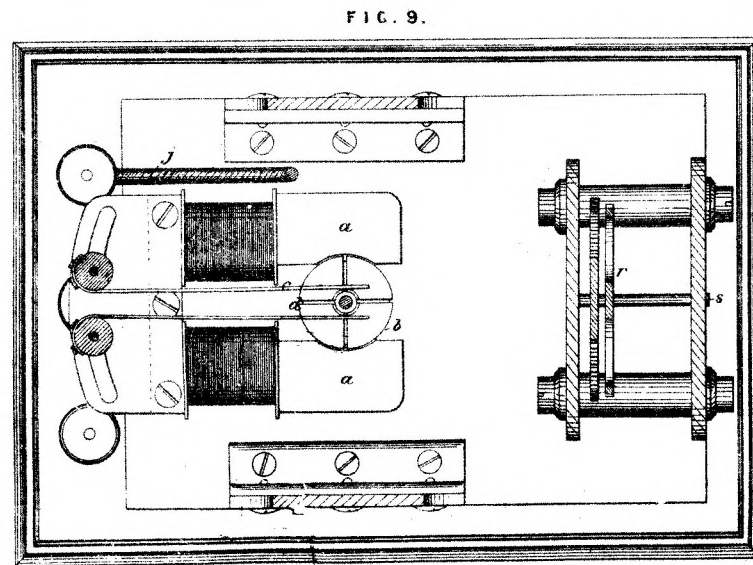
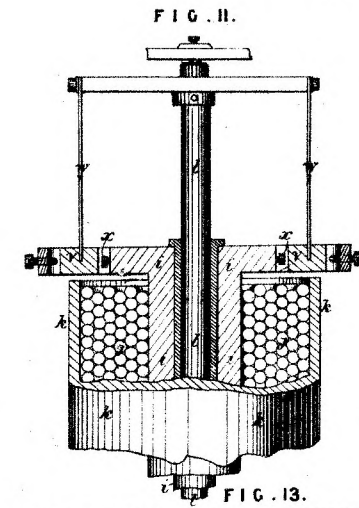
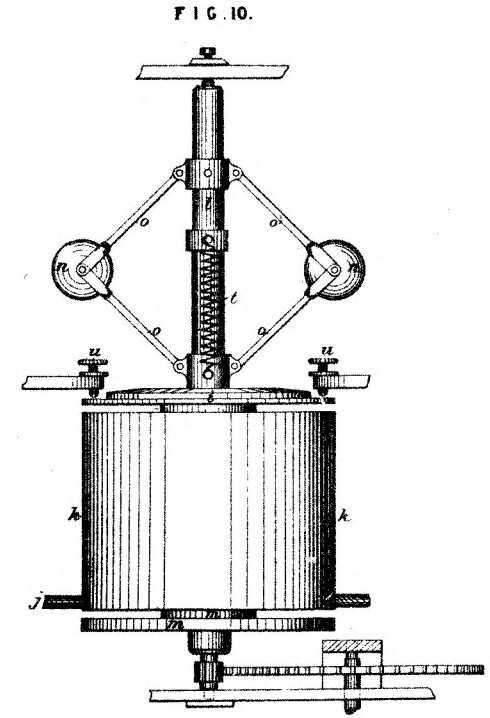
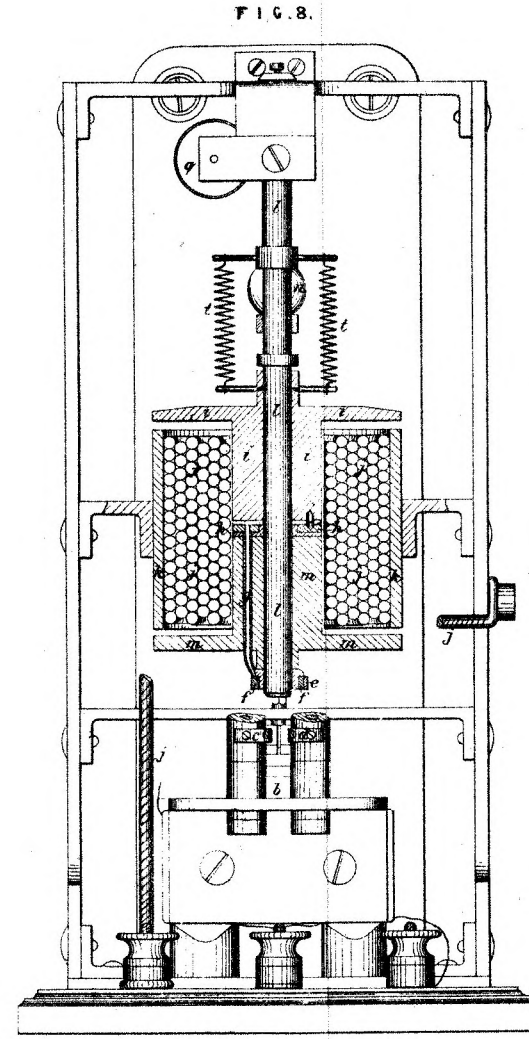
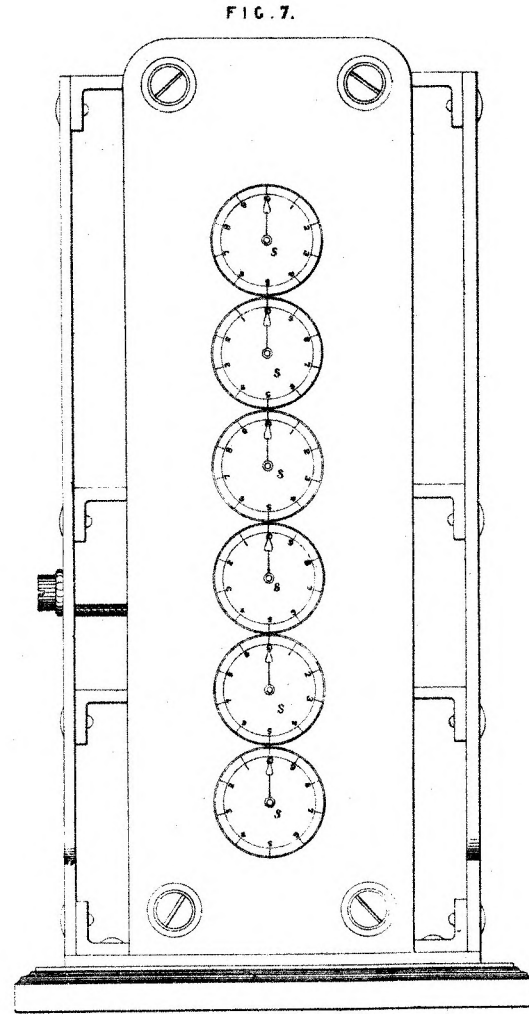
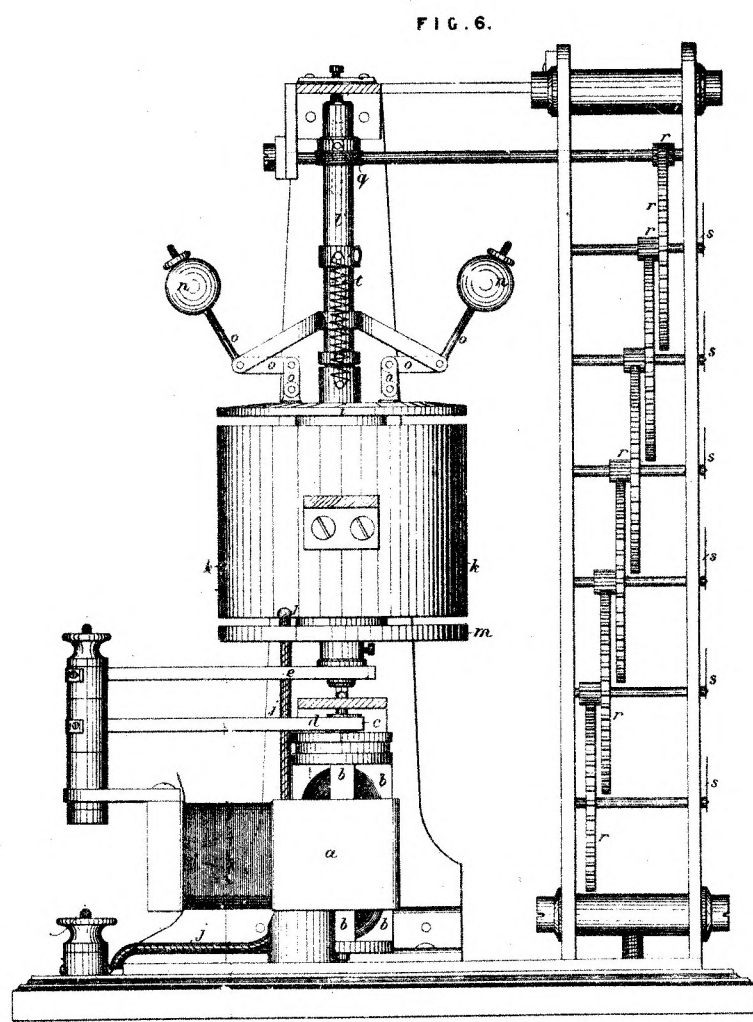


(Sig: 245~)

This is the Sheet of Drawings marked C referred to in the annexed Letters of Registration, granted to John Hopkinson, the sixteenth day of July, A. D., 1884.

Augustus Loftus.

PHOTO-LITHOGRAPHED AT THE GOVT. PRINTING OFFICE, SYDNEY, NEW SOUTH WALES.



(Sig: 245)

This is the Sheet of Drawings marked B, referred to in the annexed Letters of Registration, granted to John Hopkinson, the sixteenth day of July, A. D., 1884.

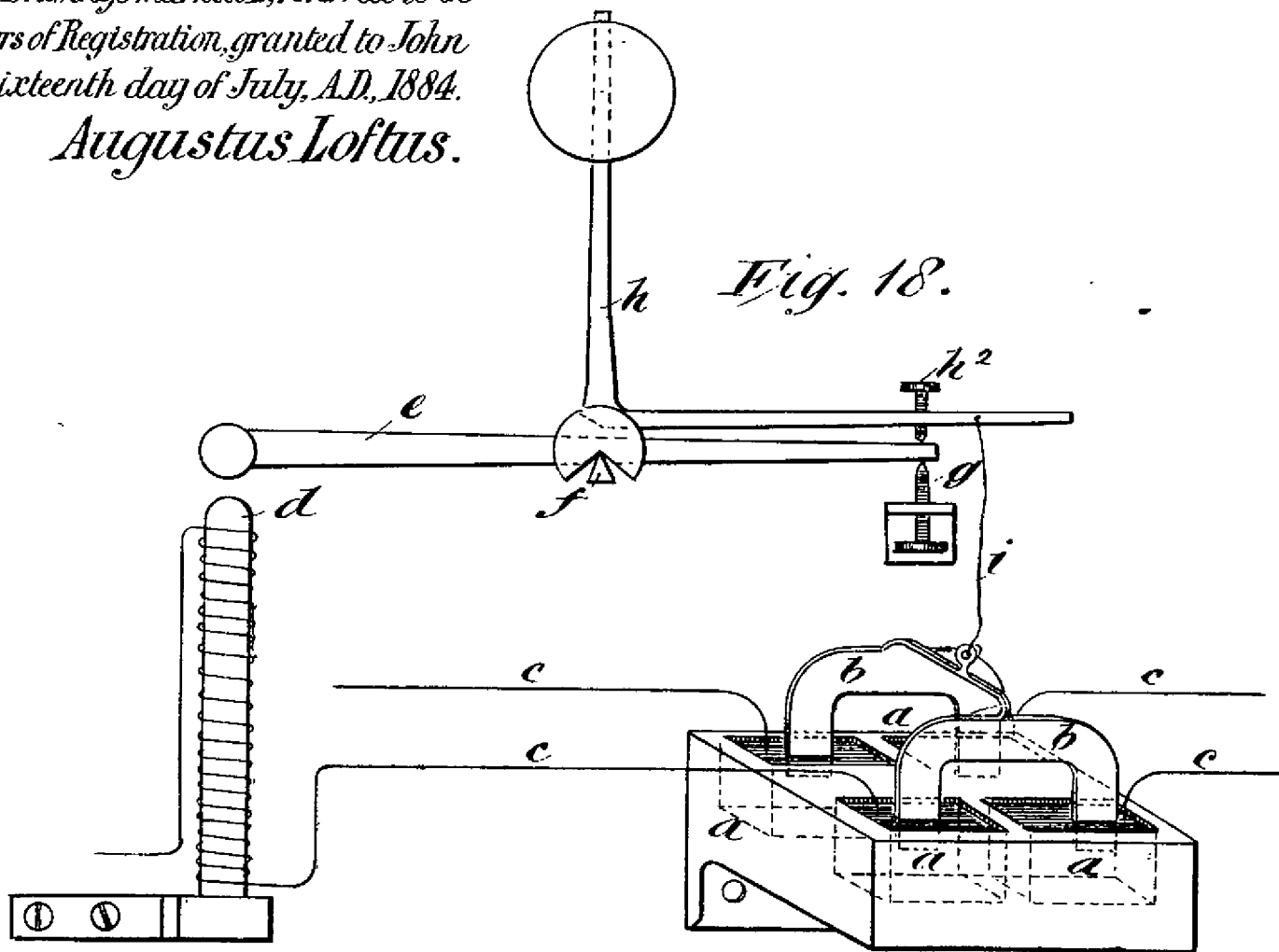
Augustus Loftus.

PHOTO-LITHOGRAPHED AT THE GOVT. PRINTING OFFICE, SYDNEY, NEW SOUTH WALES.

This is the Sheet of Drawings marked D, referred to in the annexed Letters of Registration, granted to John Hopkinson, the sixteenth day of July, A.D., 1884.

Augustus Loftus.

Fig. 18.





A.D. 1884, 24th July. No. 1466.

AN IMPROVED PROCESS OF PREPARING DOUGH FOR MANUFACTURE INTO
BISCUITS AND CAKES.

LETTERS OF REGISTRATION to Thomas Swallow, Frederick Thomas Derham,
and William Henry Swallow, for an improved process of preparing Dough
for manufacture into Biscuits and Cakes.

[Registered on the 25th day of July, 1884, in pursuance of the Act 16 Vic. No. 24.]

BY HIS EXCELLENCY THE RIGHT HONORABLE SIR AUGUSTUS WILLIAM FREDERICK SPENCER LOFTUS
(commonly called LORD AUGUSTUS LOFTUS), Knight Grand Cross of the Most Honorable Order of the
Bath, a Member of Her Majesty's Most Honorable Privy Council, Governor and Commander-in-Chief
of the Colony of New South Wales and its Dependencies.

TO ALL TO WHOM THESE PRESENTS SHALL COME, greeting :

WHEREAS THOMAS SWALLOW, FREDERICK THOMAS DERHAM, and WILLIAM HENRY SWALLOW, all of
No. 4, Queen-street, Melbourne, in the Colony of Victoria, biscuit-makers, have by their Petition humbly repre-
sented to me that your Petitioner, the said Thomas Swallow, is the author or designer of a certain invention
or improvement in manufactures, that is to say, of an invention entitled "An improved process of preparing
Dough for manufacture into Biscuits and Cakes," which is more particularly described in the specification
which is hereunto annexed ; and that your Petitioners, the said Frederick Thomas Derham and William
Henry Swallow, are the assignees of the said Thomas Swallow, of and in the said invention so far as the
Colony of New South Wales is concerned, to enable them to obtain Letters of Registration for such inven-
tion in the said Colony of New South Wales jointly with the said Thomas Swallow ; and that they, the said
Petitioners, have deposited with the Honorable the Treasurer of the said Colony of New South Wales the
sum of Twenty Pounds sterling, for defraying the expense of granting these Letters of Registration, as
required by the Act of Council, sixteenth Victoria, number twenty-four ; and have humbly prayed that I
would be pleased to grant Letters of Registration, whereby the exclusive enjoyment and advantage of the
said invention or improvement might be secured to them for a period of fourteen years : And I, being willing
to give encouragement to all inventions and improvements in the arts or manufactures which may be for the
public good, and having received a report favourable to the prayer of the said Petition, from competent
persons appointed by me to examine and consider the matters stated therein and to report thereon for my
information, am pleased, with the advice of the Executive Council, and in exercise of the power and
authority given to me by the said Act of Council, to grant, and do by these Letters of Registration grant
unto the said Thomas Swallow, Frederick Thomas Derham, and William Henry Swallow, their executors,
administrators, and assigns, the exclusive enjoyment and advantage of the said invention or improvement,
for and during the term of fourteen years from the date hereof ; to have, hold, and exercise unto the said
Thomas Swallow, Frederick Thomas Derham, and William Henry Swallow, their executors, administrators,
and assigns, the exclusive enjoyment and advantage thereof, for and during and unto the full end and term
of fourteen years from the date of these presents next and immediately ensuing, and fully to be complete and
ended : Provided always, that if the said Thomas Swallow, Frederick Thomas Derham, and William Henry
Swallow shall not, within three days after the granting of these Letters of Registration, register the same
in the proper office in the Supreme Court, at Sydney, in the said Colony of New South Wales, then these
Letters of Registration, and all advantages whatsoever hereby granted, shall cease and become void.

In witness whereof, I have hereunto set my sign manual, and have caused the present Letters of
Registration to be sealed with the seal of the said Colony of New South Wales, at Govern-
ment House, Sydney, in New South Wales, this twenty-fourth day of July, in the year of our
Lord one thousand eight hundred and eighty-four.

[L.S.]

AUGUSTUS LOFTUS.

An improved process of preparing Dough for manufacture into Biscuits and Cakes.

SPECIFICATION of THOMAS SWALLOW, FREDERICK THOMAS DERHAM, and WILLIAM HENRY SWALLOW, all of No. 4, Queen-street, Melbourne, in the Colony of Victoria, biscuit-makers, the assignees of said Thomas Swallow, the inventor of an invention entitled "An improved process of preparing Dough for manufacture into Biscuits and Cakes."

Our improved process of preparing dough for manufacture into biscuits and cakes consists in mixing flour with aerated water, syrup, or other liquid in an open vessel. We are aware that it is by no means a novel invention to make dough from aerated water, but it has always been done hitherto in closed air-tight vessels, and generally under pressure. Furthermore, we are not aware that biscuit dough was ever attempted to be made from aerated water, but only dough for manufacture into loaves of bread. Now, by this process the ordinary open mixing vessels can be used, so that all that is necessary to be added to an ordinary biscuit-making plant is, first, a gas-producing machine, and, secondly, a closed air-tight vessel for each mixer, to contain the aerated water, syrup, or other liquid to be used in compounding the dough. Of course there must be a pipe from the gas-producer to each reservoir of liquid, and a pipe from the reservoir to the mixer it supplies, together with cocks, gauges, &c., as is well understood. By this means we are enabled to dispense with the use of carbonate of soda, tartaric acid, and ammonia, and so to produce a more wholesome as well as a whiter article than can be produced by the ordinary processes now in use, and at a less cost.

Having thus described the nature of this invention, and the manner of performing same, we would have it clearly understood that we do not claim the use of aerated dough in the manufacture of bread, nor do we claim its use in the manufacture of biscuits or cake when such dough is made under pressure or in closed air-tight vessels, but what we do claim is—

The preparation of dough for manufacture into biscuits and cakes by mixing flour with aerated water, syrup, or other liquid *in an open vessel*, in contradistinction to air-tight vessels, substantially as herein described and explained.

In witness whereof, we, the said Thomas Swallow, Frederick Thomas Derham, and William Henry Swallow, have hereto set our hands and seals, this ninth day of May, one thousand eight hundred and eighty-four.

THOS. SWALLOW.
FREDK. T. DERHAM.
W. H. SWALLOW.

Witness—

F. LINEKER,
Clerk, 4, Queen-street.

This is the specification referred to in the annexed Letters of Registration granted to Thomas Swallow, Frederick Thomas Derham, and William Henry Swallow, the twenty-fourth day of July, A.D. 1884.

AUGUSTUS LOFTUS.

REPORT.

Sir,

Sydney, 20 May, 1884.

The application of Messrs. Swallow, Derham, and Swallow for Letters of Registration for an invention entitled "An improved process of preparing Dough for manufacture into Biscuits and Cakes," having been referred to us, we have examined the specification accompanying the same, and have now the honor to report that we see no objection to the issue of Letters of Registration as applied for.

We have, &c.,

ARCH. C. FRASER.
THOS. RICHARDS.

The Under Secretary of Justice.



A.D. 1884, 29th July. No. 1467.

IMPROVEMENTS IN MECHANICAL APPLIANCES OR APPARATUS FOR COALING
LOCOMOTIVE ENGINES, &c.

LETTERS OF REGISTRATION to Thomas Midelton and Thomas Sellwood, for Improvements in Mechanical Appliances or Apparatus for Coalng Locomotive Engines, and removing Ashes from Engine-pits, Locomotive Depôts, and other places.

[Registered on the 30th day of July, 1884, in pursuance of the Act 16 Vic. No. 24.]

BY HIS EXCELLENCY THE RIGHT HONORABLE SIR AUGUSTUS WILLIAM FREDERICK SPENCER LOFTUS (commonly called LORD AUGUSTUS LOFTUS), Knight Grand Cross of the Most Honorable Order of the Bath, a Member of Her Majesty's Most Honorable Privy Council, Governor and Commander-in-Chief of the Colony of New South Wales and its Dependencies.

TO ALL TO WHOM THESE PRESENTS SHALL COME, greeting :

WHEREAS THOMAS MIDEULTON, engineer, and THOMAS SELLWOOD HUNTLEY, auctioneer, both of Sydney, have by their Petition humbly represented to me that they are the authors or designers of a certain invention or improvement in manufactures, that is to say, of an invention entitled "An Invention for Improvements in Mechanical Appliances or Apparatus for Coalng Locomotive Engines, and removing Ashes from Engine-pits, Locomotive Depôts, and other places," which is more particularly described in the specification, marked "A," and the two sheets of drawings, marked "B" and "C" respectively, which are herewith annexed; and that they, the said Petitioners, have deposited with the Honorable the Treasurer of the said Colony of New South Wales, the sum of Twenty Pounds sterling for defraying the expense of granting these Letters of Registration, as required by the Act of Council, sixteenth Victoria, number twenty-four; and have humbly prayed that I would be pleased to grant Letters of Registration, whereby the exclusive enjoyment and advantage of the said invention or improvement might be secured to them for a period of fourteen years: And I, being willing to give encouragement to all inventions and improvements in the arts or manufactures which may be for the public good, and having received a report favourable to the prayer of the said Petition from competent persons appointed by me to examine and consider the matters stated therein and to report thereon for my information, am pleased, with the advice of the Executive Council, and in exercise of the power and authority given to me by the said Act of Council, to grant, and do by these Letters of Registration grant unto the said Thomas Midelton and Thomas Sellwood Huntley, their executors, administrators, and assigns, the exclusive enjoyment and advantage of the said invention or improvement, for and during the term of fourteen years from the date hereof; to have, hold, and exercise unto the said Thomas Midelton and Thomas Sellwood Huntley, their executors, administrators, and assigns, the exclusive enjoyment and advantage thereof, for and during and unto the full end and term of fourteen years from the date of these presents next and immediately ensuing, and fully to be complete and ended: Provided always, that if the said Thomas Midelton and Thomas Sellwood Huntley shall not, within three days after the granting of these Letters of Registration, register the same in the proper office in the Supreme Court, at Sydney, in the said Colony of New South Wales, then these Letters of Registration and all advantages whatsoever hereby granted, shall cease and become void.

In witness whereof, I have hereunto set my sign manual, and have caused the present Letters of Registration to be sealed with the seal of the said Colony of New South Wales, at Government House, Sydney, in New South Wales, this twenty-ninth day of July, in the year of our Lord one thousand eight hundred and eighty-four.

[L.S.]

AUGUSTUS LOFTUS.

Improvements in Appliances or Apparatus for Coaling Locomotive Engines, &c.

"A."

TO ALL TO WHOM THESE PRESENTS SHALL COME, We, THOMAS MIDDLETON, engineer, and THOMAS SELLWOOD HUNTLEY, auctioneer, both of Sydney, in the Colony of New South Wales, send greeting :

WHEREAS we are desirous of obtaining Letters of Registration for securing unto us Her Majesty's Special License, that we, our executors, administrators, and assigns, and such others as we or they shall at any time agree with, and no others, shall, and lawfully may, from time to time, and at all times, during the term of fourteen years, from the day on which this instrument shall be left at the office of the Minister of Justice, Sydney, make, use, exercise, and vend, within the Colony of New South Wales, an "Invention for Improvements in Mechanical Appliances or Apparatus for Coaling Locomotive Engines, and removing Ashes from Engine-pits, Locomotive Depôts, and other places," as more particularly shown and described in the following specification and accompanying plans

SPECIFICATION.

1. Our invention consists of a novel method of loading and transporting coals from a colliery siding or ship's side to any point on the line of railway, by means of squared boxes, made to fit a particular seat on a bogie platform truck, or an ordinary four-wheeled waggon may be used. These boxes may be made to suit any required capacity or shape; but a square shape, with a capacity of 10 cwt., is preferred, as being easily stored and handled in loading or discharging. These are lifted from the waggon by means of a revolving steam or hand crane, and tipped into the engine tender standing on the main line, and are capsized when being lowered by means of a tripping-line, affixed to the end of the crane-jib and hooked into a hole for this purpose, or by other suitable mechanical contrivance. The box when emptied is self-righting.

2. While the engine is coaling, the ashes may be drawn from the ash-pan into one of the coal-boxes, placed in a travelling hopper-guide or otherwise in the engine-pit to receive the ashes, and when filled may be removed by the same crane as was used for the coaling, and emptied in the same manner as above described into a ballast or other waggon kept in reserve for this purpose, which, by preference, should be attached to the crane engine, and when loaded removed in the ordinary way. This method reduces the labour required in removing the ashes to a minimum. The hopper-guide is movable by hand, backwards or forwards, in the pit, as required, by means of small wheels and rails laid below and inside of the main rails. The box is dropped into the hopper-guide, and may be made to rest upon a skeleton frame or clips.

3. The steam crane employed for this purpose may be fixed on the foot-plate of an old locomotive, which may also be used for shunting purposes, or may be fixed on a platform waggon with propelling gear, or a Dub's steam crane may be used. This system is well adapted for a colliery siding where convenient, thus saving the cost of haulage from the mine to the coaling depôt, with the usual labour and expense of discharge from trucks to platform, and thence to tender, as now practised.

4. Drawing No. 1 shows the system of coaling at a colliery siding, locomotive, or coal depôts. Two kinds of cranes are shown. The ground plan shows the coal waggon on one line, the cranes on another, and the engines on main line. Sections of engine-pit and ash-boxes are shown, and the method of suspending ash-box on wheels and frame.

It will also be possible to place the coal waggon and ballast waggon on same line of rails as the crane engine, the latter being placed between the two waggons.

5. Drawing No. 2 shows the method of removing ashes by mechanical means, and is especially suitable for locomotive depôts. A tunnel is formed at right-angles through engine-pits, under (say) six or any other number of lines of rails, at the entrance of a running shed, and openings formed between the rails into the tunnel to receive fixed hoppers. In the tunnel is placed a flexible belt, with raised sides, travelling on rollers worked by steam, or any other motive power available, to receive from the mouth of the ash-hoppers the ashes from time to time drawn into them from the ash-pans and fire-boxes of the engines as they pass out over them into the shed. The ashes are allowed to deposit themselves on the belt gradually by means of a slooping shoot forming the outlets, thus relieving the vertical pressure which would otherwise rest on the belts. They are carried by the belt to a receiving-pit at one end, thence lifted by an elevator into a waggon for removal.

We do not bind ourselves to the precise details herein given, as they may be varied without departing from the general scheme embodied in this specification.

CLAIMS.

Having thus described our invention and the manner of working the same, we claim that it is a novel application of mechanical force to the coaling locomotives and relieving them of waste ashes, and that the adoption of the scheme will conduce to great economy for the public good. And we claim the entire scheme of the application of the machinery for the purpose and in the manner substantially described and set forth herein.

THOMAS MIDDLETON, Engineer.

THOMAS SELLWOOD HUNTLEY, Auctioneer.

2, Wentworth Court, Sydney, 11 June, 1884.

(By their Agent, HENRY HALLORAN, Patent Agent.)

This is the specification, marked "A," referred to in the annexed Letters of Registration granted to Thomas Middleton and Thomas Sellwood Huntley, the twenty-ninth day of July, A.D. 1884.

AUGUSTUS LOFTUS.

REPORT.

Sir,

Sydney, 27 June, 1884.

In reference to your B.C. of 13th instant, forwarding a Petition for Letters of Registration for an invention entitled "Improvements in Mechanical Appliances or Apparatus for Coaling Locomotive Engines and removing Ashes from Engine-pits, Locomotive Depôts, and other places," the Petitioners being Messrs. T. Middleton and T. S. Huntley, we have the honor to inform you that, having examined the plan and specification accompanying the Petition, we are of opinion that Letters of Registration for the invention may be issued in accordance with the prayer of the Petitioners.

We have, &c.,

JOHN WHITTON.

E. O. MORIARTY.

The Under Secretary of Justice.

[Drawings—two sheets.]

C

MIDELTON & HUNTLEY'S COMBINED SCHEME

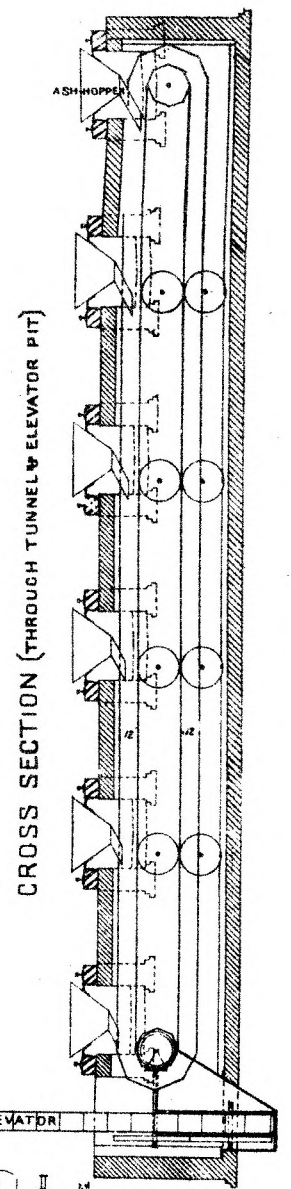
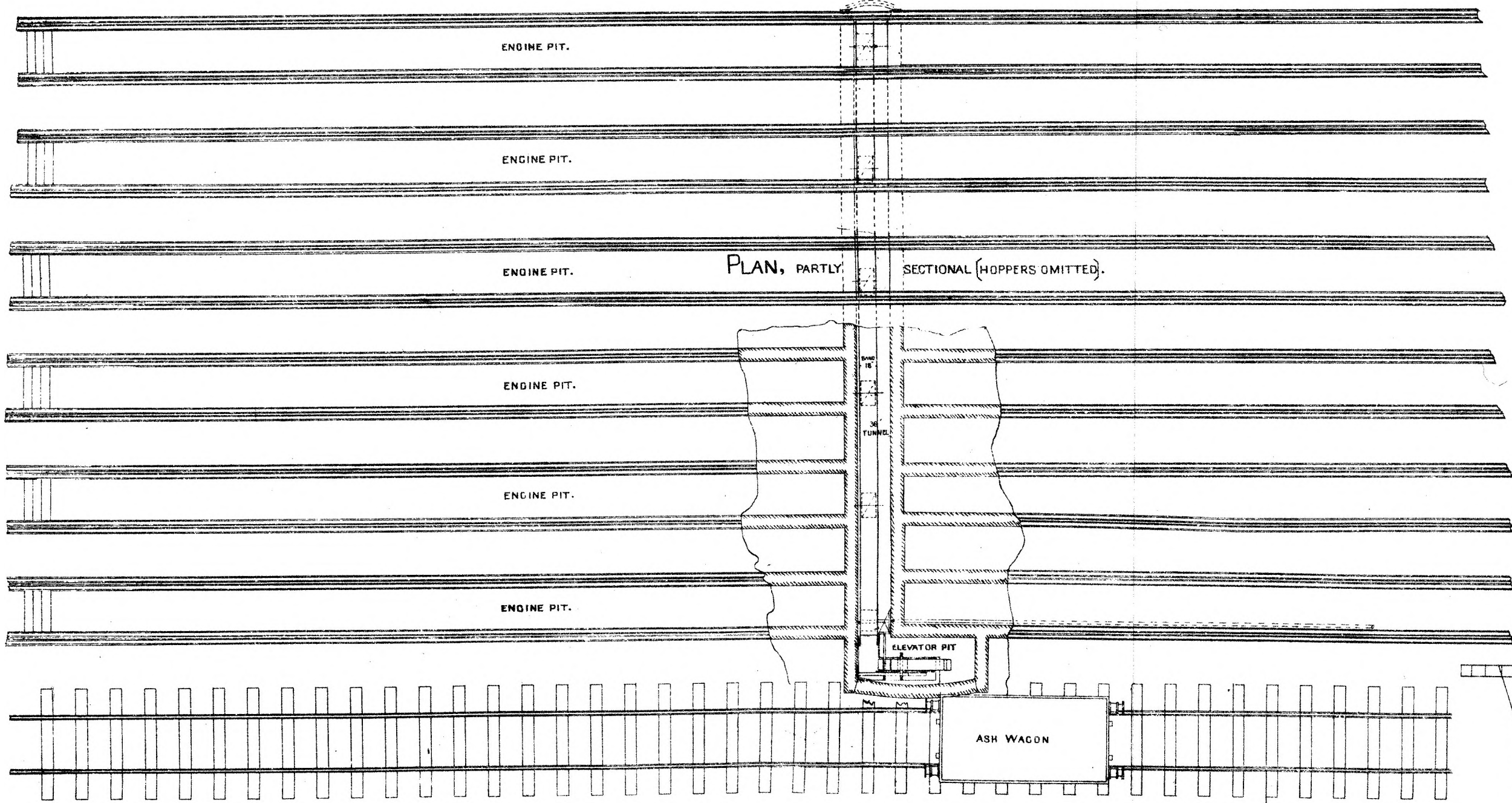
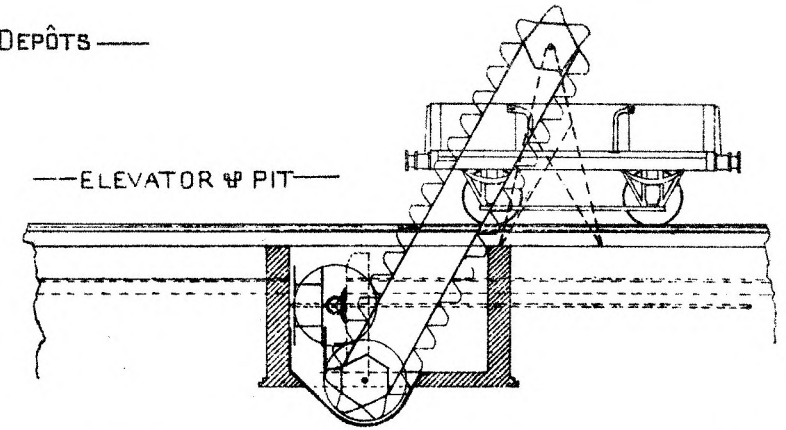
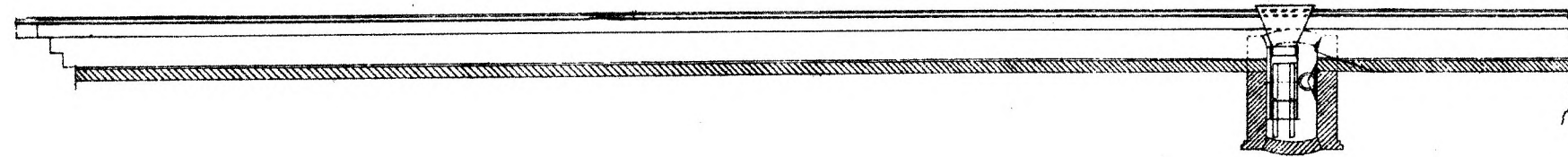
FOR COALING LOCOMOTIVES, & REMOVING ASHES AT RAILWAY STATIONS & LOCOMOTIVE DEPÔTS

1/4" SCALE

SECTIONAL ELEVATION

ELEVATOR & PIT

1467



CROSS SECTION (THROUGH TUNNEL & ELEVATOR PIT)

DRAWING N° 2

PHOTO-LITHOGRAPHED AT THE GOVT. PRINTING OFFICE, SYDNEY, NEW SOUTH WALES.

This is the Sheet of Drawings marked C referred to in the annexed Letters of Registration granted to Thomas Middleton, and Thomas Saltwood Huntley, the twenty ninth day of July, AD 1884 Augustus Loftus

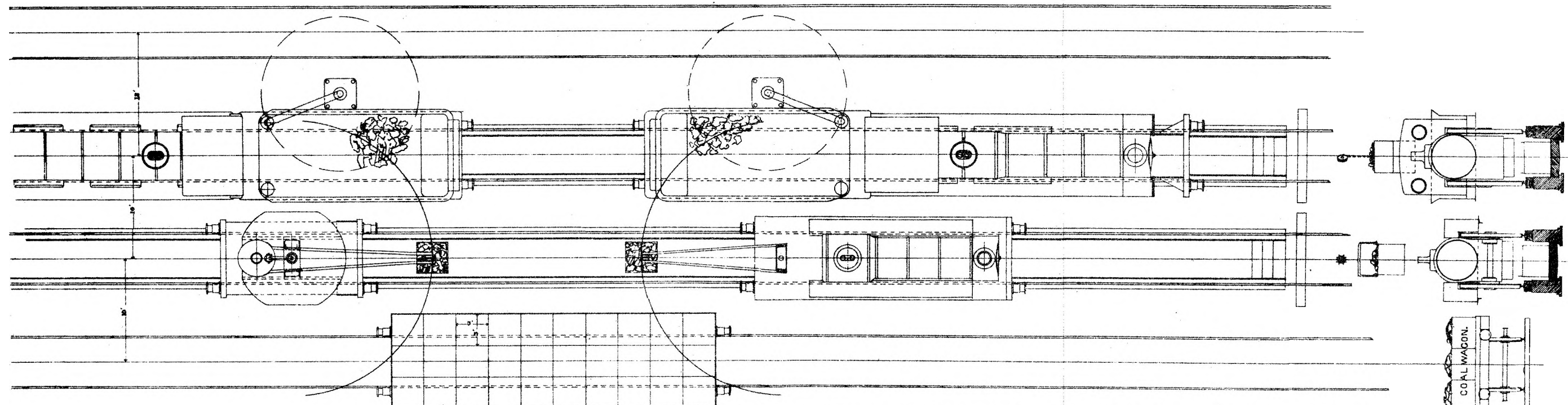
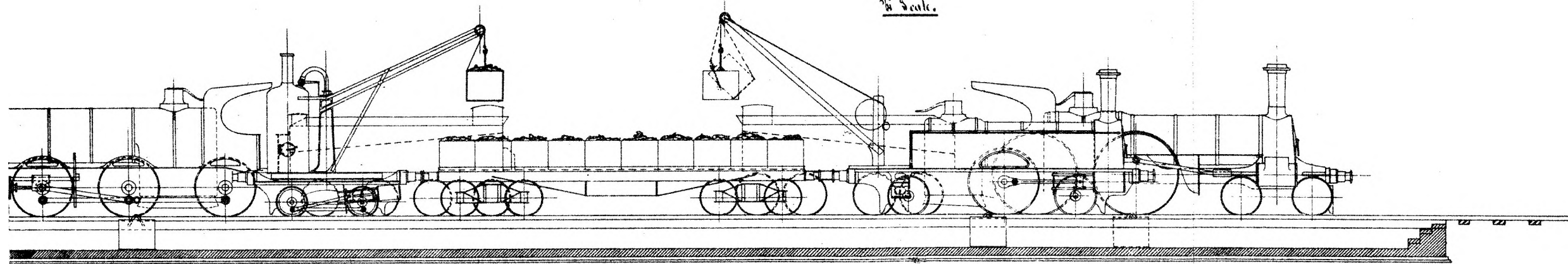
(Sig 245)

"B"

MIDDELTON & HUNTLEY'S COMBINED SCHEME
FOR COALING LOCOMOTIVES AND REMOVING ASHES FROM PITS, AT RAILWAY STATIONS & LOCOMOTIVE DEPÔTS.

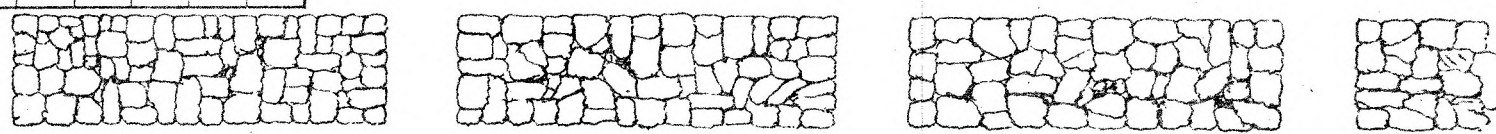
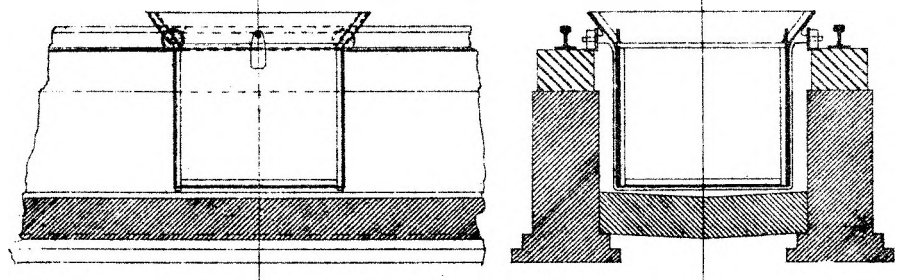
1467

$\frac{1}{8}$ Scale.



$\frac{1}{4}$ Scale.

BOX & HOPPER-GUIDE, $\frac{1}{2}$ SCALE.



RESERVE COAL HEAPS.

$\frac{1}{4}$ Scale.

DRAWING N° 1

(Sig. 245-)

This is the Sheet of Drawings marked B referred to in the annexed Letters of Registration, granted to Thomas Middleton, and Thomas Sellwood Bramley, the twenty ninth day of July, A.D. 1884.
Augustus Loftus.



A.D. 1884, 29th July. No. 1468.

IMPROVEMENTS IN AMALGAMATING MACHINES.

LETTERS OF REGISTRATION to Henry Moon, for Improvements in Amalgamating Machines.

[Registered on the 30th day of July, 1884, in pursuance of the Act 16 Vic. No. 24.]

BY HIS EXCELLENCY THE RIGHT HONORABLE SIR AUGUSTUS WILLIAM FREDERICK SPENCER LOFTUS (commonly called LORD AUGUSTUS LOFTUS), Knight Grand Cross of the Most Honorable Order of the Bath, a Member of Her Majesty's Most Honorable Privy Council, Governor and Commander-in-Chief of the Colony of New South Wales and its Dependencies.

TO ALL TO WHOM THESE PRESENTS SHALL COME, greeting:

WHEREAS HENRY MOON, at present of Leicester, in the county of Leicester, England, but lately of Thomasville in the county of Davidson, and State of North Carolina, in the United States of America, mining and mechanical engineer, hath by his Petition humbly represented to me that he is the author or designer of a certain invention or improvement in manufactures, that is to say, of an invention entitled "Improvements in Amalgamating Machines," which is more particularly described in the specification, marked A, and the two sheets of drawings, marked B and C respectively, which are hereunto annexed; and that he, the said Petitioner, hath deposited with the Honorable the Treasurer of the said Colony of New South Wales the sum of Twenty Pounds sterling, for defraying the expense of granting these Letters of Registration, as required by the Act of Council, sixteenth Victoria, number twenty-four; and hath humbly prayed that I would be pleased to grant Letters of Registration, whereby the exclusive enjoyment and advantage of the said invention or improvement might be secured to him for a period of fourteen years: And I, being willing to give encouragement to all inventions and improvements in the arts or manufactures which may be for the public good, and having received a report favourable to the prayer of the said Petition, from competent persons, appointed by me to examine and consider the matters stated therein and to report thereon for my information, am pleased, with the advice of the Executive Council, and in exercise of the power and authority given to me by the said Act of Council, to grant, and do by these Letters of Registration grant unto the said Henry Moon, his executors, administrators, and assigns, the exclusive enjoyment and advantage of the said invention or improvement, for and during the term of fourteen years from the date hereof; to have, hold, and exercise unto the said Henry Moon, his executors, administrators, and assigns, the exclusive enjoyment and advantage thereof, for and during and unto the full end and term of fourteen years from the date of these presents next and immediately ensuing, and fully to be complete and ended: Provided always, that if the said Henry Moon shall not, within three days after the granting of these Letters of Registration, register the same in the proper office in the Supreme Court at Sydney, in the said Colony of New South Wales, then these Letters of Registration, and all advantages whatsoever hereby granted, shall cease and become void.

In witness whereof, I have hereunto set my sign manual, and have caused the present Letters of Registration to be sealed with the seal of the said Colony of New South Wales, at Government House, Sydney, in New South Wales, this twenty-ninth day of July, in the year of our Lord one thousand eight hundred and eighty-four.

[L.S.]

AUGUSTUS LOFTUS.

Improvements in Amalgamating Machines.

A.

SPECIFICATION of HENRY MOON, at present of Leicester, in the county of Leicester, England, but lately of Thomasville, in the county of Davidson and State of North Carolina, in the United States of America, mining and mechanical engineer, for an invention, entitled "Improvements in Amalgamating Machines."

THE said invention consists in providing a vibratory amalgamating pan with an inwardly curved end of a peculiar construction, whereby in the longitudinal reciprocating movement of the said pan the mercury or amalgam contained therein is at each stroke of the pan, caused to curl or lap over after the manner of a wave, and to thereby enclose and amalgamate particles of gold floating on the surface of the water and ore.

It further consists in providing the said vibratory pan with a reciprocating mixer, which moves in practically the same plane as the amalgamating-pan, but at an increased speed, to keep the reduced ore and water in a state of agitation, and thereby prevent the ore becoming packed into a solid body.

It further consists in certain details of construction of the apparatus, looking to its efficient operation, as hereinafter fully described.

In the accompanying drawings, figure 1 is an exterior side view of one arrangement of the improved amalgamator, and figure 2 an end view of the same. Figures 3, 4, and 5 are respectively a longitudinal section, a plan view and an end view of the entrance shoot end of the amalgamating-pan and mixer.

Similar letters of reference indicate similar parts in all the views.

A represents a portion of the frame from which the amalgamating-pan B and mixer C depend. The amalgamating-pan is here shown as consisting of a wooden trough *a*, with its bottom and sides covered with iron plates *b*, and one end provided with the wave-plate *c*.

By reference to figure 3 of the drawings, it will be seen that the upper edge of the wave-plate *c* extends beyond a central vertical line, and approaches the surface of the mercury or amalgam. Consequently, in a rapid longitudinal reciprocating movement of the pan, the mercury or amalgam is not only carried up the hollow surface of the wave-plate but introverted and brought back in a solid sheet which envelops the float gold on the surface of the water or in the water near to it.

The amalgamating-pan may be made entirely of iron if desired. As the wave-plate *c* does not necessarily extend to the upper edge of the pan B, it is provided with an extension *d*, which may be either inclined, as shown in the drawings, or vertical. The inner curved surface of the wave-plate *c* is accurately bored or faced, and its lower end rabbeted, in order that a tight joint may be formed with the bottom plate *b*. The said plate *b* is inclined downward toward the wave-plate *c*, so that a body of mercury is maintained in the pan. In order to obtain the desired inclination of the bottom of the pan B without increasing the depth of mercury contained therein, the said bottom is formed in two or three sections, with an offset where they are connected. This offset, which is represented by *e*, is curved in a manner similar to the wave-plate; but it is not absolutely necessary to the proper operation of the invention that the offset should occur or that it should be curved as shown.

C is the mixer, consisting of a frame *f*, preferably of wood, having projections *g* on its under side. These projections have a V cross-section, and they are arranged so that one transverse row is opposite the spaces in the row immediately behind it. By this means, in the reciprocal movement of the mixer, the portion of the contents of the pan upon which it acts is driven in small streams through the apertures between the projections *g* towards the back end of the pan, and it flows back to the front end by the force of gravity.

The pan B is suspended by means of rods *h* from the frame A, and it will be seen that these rods, which are spread at their upper ends to give rigidity to the apparatus, are adjustable in length for obvious purposes. The mixer is also suspended from the frame A by means of rods *i*, corresponding practically with the ones *h*.

By reference to the drawings it will be seen that when the pan is at rest its contents (amalgam, ore, and water) will occupy the space below the dotted line *y y*, and that the projections *g* of the mixer extend below the surface of the contents of the pan, but do not touch the plates *b*. The pan and mixer receive their reciprocating movements from eccentrics, cranks, or other similar devices which are connected to them by means of the rods *k* and *l*.

It is designed to give the amalgamating pan about seventy-five or eighty double strokes per minute, and the mixer about 160; but the speed of either device may be increased or diminished as desired.

The pulverized ore from the stamps or other crushing or grinding apparatus and water are introduced to the pan B through the trough or shoot D, and the overflow from the pan escapes through a similar shoot E.

Figure 6 is a sectional side elevation and figure 7 is a sectional plan drawn on a larger scale than figures 1 to 5 of a somewhat modified form of amalgamator, also constructed according to this invention, wherein similar letters of reference indicate like parts to those in previous figures. Here the amalgamating-pan may be made, as described in the previous case, entirely of iron, or of wood lined with iron, as may be desired. As the wave-plate does not necessarily extend to the upper edge of the pan B, it is provided as before with an extension *d*, which may be either vertical or inclined, as shown, and which may reach to the edge of the pan and as shown at figure 6. I also sometimes provide a further horizontal extension *d'* at the base of the vertical or inclined extension *d*, and starting from the edge of the curved portion of the wave-plate, which horizontal extension *d'* does not preferably exceed one-fourth of the diameter of the circle of the wave-plate, and I may use the horizontal extension *d'* without the vertical or inclined extension *d*, according to circumstances. The bottom *b* is here made in three parts or sections, and has at the junction of the first two sections a second wave-plate *c'*, as shown. This second wave-plate causes the water and crushed ore to pass a second time through a wave of mercury, and any gold which may have escaped the first wave is amalgamated and retained. I use in connection with the second wave-plate *c'* a plate *b'* fixed to the pan B to guide the ore and water which overflows from the first section of the bottom *b* into the second wave of mercury. The offset *e* at the commencement of the third

Improvements in Amalgamating Machines.

third section of the bottom *b* is curved in a manner somewhat similar to the wave-plates, but this, as before stated, is not absolutely necessary.

The contents of the pan are driven between the projections *g* of the mixer towards the open end of the pan, from which it escapes by force of gravity. The pan suspending rods *h*, while giving rigidity to the structure, maintain a parallel motion of the pan.

F is a box or funnel, with wide open top, into which the ore and water fall from the shoot *D*, and a narrow opening at the bottom for the escape of the materials. This box or funnel is slightly less in width than the pan *B*, and is suspended from any suitable support so as to hang within the pan with its open bottom a little above the introverted edge *d* of the wave-plate. The funnel *F* is at its other end connected at or near the extension *d* of the wave-plate by means of a hook or link *G*, in order that the distance between the wave-plate and the discharge end of the funnel is the same at all parts of the stroke of the pan. By means of this vibratory funnel the ore and water are introduced into the wave of mercury.

In the operation of the machine the mercury or amalgam at each stroke of the pan impinges against the wave-plate *c*, and following its curved surface is introverted in the form of a wave as hereinbefore described, and this movement encloses a portion of the ore and water which, to escape from their enclosure, have to pass through a body of mercury, and the free gold therein is thus amalgamated. In the continued operation of the apparatus, which includes the mixer, the whole of the ore and water is thus made to pass through a solid body of mercury, as described. The value of this wave action of the mercury will be apparent when it is understood that in all ground ore a large proportion of the gold contained therein is in so minute a state of comminution that it will float on the surface of water, and this extreme levity of the particles of gold renders the ordinary amalgamating process exceedingly wasteful. In this amalgamator the floating gold is caught by the forced wave of mercury and amalgamated.

Having now particularly described and ascertained the nature of the said invention, and in what manner the same is to be performed, I declare that I am aware that amalgamating pans have been made with a curved inwardly projecting end, but in all such pans the curved surface has either been less than a semicircle, or if projecting beyond a vertical line extending through the centre from the curve as described, has had an ascending inclination. In both these constructions there is nothing to guide the mercury in a curved wave toward the surface of the water and amalgam, and the mercury consequently falls in separated particles, which cannot be considered as an imperforate envelope, as is found when this construction is employed.

I do not claim broadly an amalgamating pan with an inwardly curved end, but what I claim is—

First—In an amalgamator, a longitudinally reciprocating amalgamating-pan, having at one end thereof an inwardly curved wave-plate extending downwards or toward the surface of the amalgam in the said pan, producing, when in motion, a wave of mercury, substantially as specified.

Second—In a longitudinally reciprocating amalgamating-pan providing the bottom thereof with one, two, or more wave-plates, having the horizontal extension *d*¹, and arranged at different heights within the pan, substantially as set forth.

Third—In combination with the longitudinally reciprocating pan *B* and the shoot *D*, the vibrating funnel *F* and the link *G*, substantially as and for the purposes set forth.

In witness whereof, I, the said Henry Moon, have hereto set my hand and seal this thirtieth day of April, 1884.

HENRY MOON.

This is the specification, marked "A," referred to in the annexed Letters of Registration granted to Henry Moon, the twenty-ninth day of July, A.D. 1884.

AUGUSTUS LOFTUS.

REPORT:

Sir,

The petition of Mr. Henry Moon for Letters of Registration for an invention entitled "Improvements in Amalgamating Machines" having been referred to us, we have examined the specification and drawings accompanying the same, and have now the honor to report that we see no objection to the issue of Letters of Registration as prayed for.

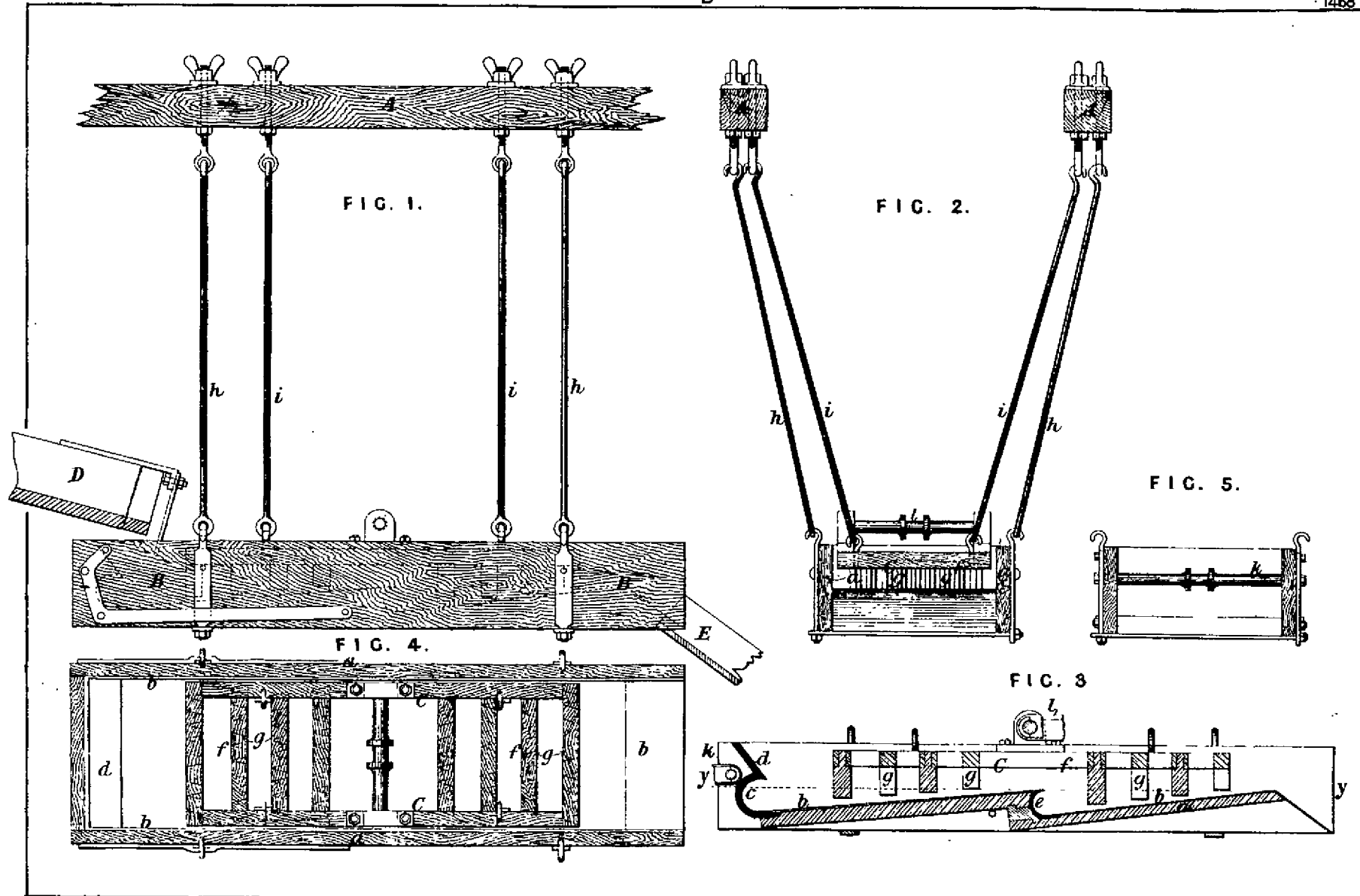
We have, &c.,

J. SMITH.

A. LEIBIUS.

The Under Secretary of Justice.

Sydney, 18 June, 1884.



*This is the Sheet of Drawings marked B referred to by the annexed
 Letters of Registration, granted to Henry Moon, the twenty ninth
 day of July, A.D. 1884.*

PHOTO-LITHOGRAPHED AT THE GOV'T. PRINTING OFFICE,
 SYDNEY, NEW SOUTH WALES

(Sig 245-)

Augustus Loftus

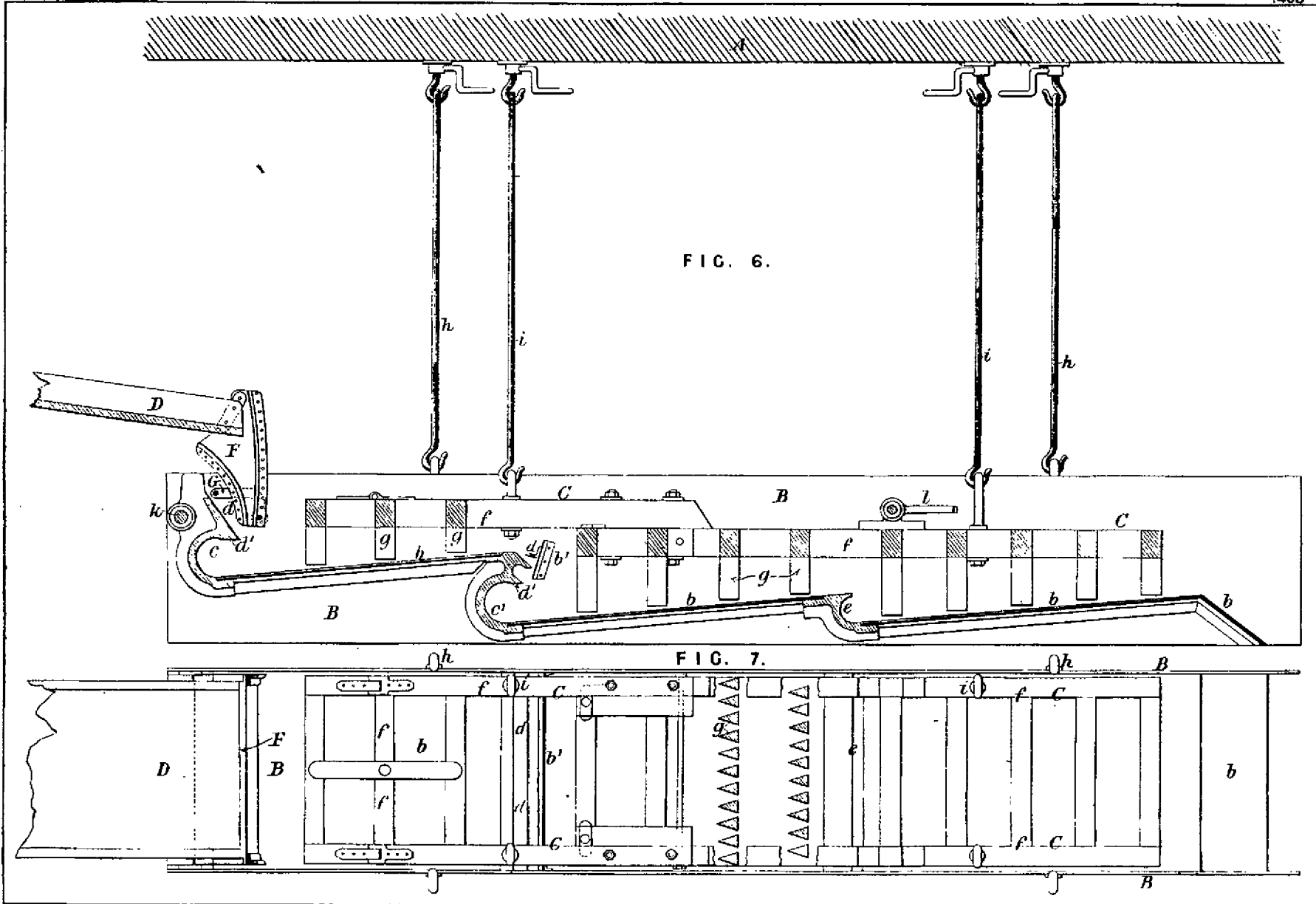


FIG. 6.

FIG. 7.

*This is the Sheet of Drawings marked C' referred to in the annexed
 Letters of Registration granted to Henry Moon, the twentythird
 day of July, A.D. 1884.*

PHOTO-LITHOGRAPHED AT THE GOVT. PRINTING OFFICE,
 SYDNEY, NEW SOUTH WALES.

(Signed)

Augustus Loftus.



A.D. 1884, 29th July. No. 1469.

IMPROVEMENTS IN ORE-SMELTING FURNACES.

LETTERS OF REGISTRATION to Edward Probert, for Improvements in Ore-smelting Furnaces.

[Registered on the 30th day of July, 1884, in pursuance of the Act 16 Vic. No. 24.]

BY HIS EXCELLENCY THE RIGHT HONORABLE SIR AUGUSTUS WILLIAM FREDERICK SPENCER LOFTUS (commonly called LORD AUGUSTUS LOFTUS), Knight Grand Cross of the Most Honorable Order of the Bath, a Member of Her Majesty's Most Honorable Privy Council, Governor and Commander-in-Chief of the Colony of New South Wales and its Dependencies.

TO ALL TO WHOM THESE PRESENTS SHALL COME, greeting :

WHEREAS EDWARD PROBERT, of San Francisco, in the United States of America, metallurgist, hath by his Petition humbly represented to me that he is the author or designer of a certain invention or improvement in manufactures, that is to say, of an invention entitled "Improvements in Ore-smelting Furnaces," which is more particularly described in the specification and the sheet of drawings which are hereunto annexed ; and that he, the said Petitioner, hath deposited with the Honorable the Treasurer of the said Colony of New South Wales the sum of Twenty Pounds sterling, for defraying the expense of granting these Letters of Registration, as required by the Act of Council, sixteenth Victoria, number twenty-four ; and hath humbly prayed that I would be pleased to grant Letters of Registration, whereby the exclusive enjoyment and advantage of the said invention or improvement might be secured to him for a period of fourteen years : And I, being willing to give encouragement to all inventions and improvements in the arts or manufactures which may be for the public good, and having received a report favourable to the prayer of the said Petition from competent persons appointed by me to examine and consider the matters stated therein and to report thereon for my information, am pleased, with the advice of the Executive Council, and in exercise of the power and authority given to me by the said Act of Council, to grant, and do by these Letters of Registration grant unto the said Edward Probert, his executors, administrators, and assigns, the exclusive enjoyment and advantage of the said invention or improvement, for and during the term of fourteen years from the date hereof ; to have, hold, and exercise unto the said Edward Probert, his executors, administrators, and assigns, the exclusive enjoyment and advantage thereof, for and during and unto the full end and term of fourteen years from the date of these presents next and immediately ensuing, and fully to be complete and ended : Provided always, that if the said Edward Probert shall not, within three days after the granting of these Letters of Registration, register the same in the proper office in the Supreme Court, at Sydney, in the said Colony of New South Wales, then these Letters of Registration, and all advantages whatsoever hereby granted, shall cease and become void.

In witness whereof, I have hereunto set my sign manual, and have caused the present Letters of Registration to be sealed with the seal of the said Colony of New South Wales, at Government House, Sydney, in New South Wales, this twenty-ninth day of July, in the year of our Lord one thousand eight hundred and eighty-four.

[L.S.]

AUGUSTUS LOFTUS. *

Improvements in Ore-smelting Furnaces.

SPECIFICATION of EDWARD PROBERT, of San Francisco, in the United States of America, metallurgist, for an invention entitled "Improvements in Ore-smelting Furnaces."

MY invention of improvements in ore-smelting furnaces relates principally to the construction of the base wall, to the arrangement of the tuyeres, and to a water-jacket which surrounds the region of fusion, and also to certain other but minor features, which are hereinafter described and specifically claimed.

The special objects or advantages to be obtained by my furnace are its large smelting capacity, the facility with which it can be repaired even while in operation, and with which the entire operation of smelting may be carried on. The first of these advantages arises from overcoming, as I shall show, the disadvantages in ordinary furnaces. It is well known that in the construction of pressure-blast furnaces of the ordinary type the diameter should never exceed twice the "throw" of the blast—that is, twice the distance to which the blast penetrates the charge, or, say, from 30 to 40 inches. This necessity limits the smelting capacity of the furnace, so that the daily production rarely exceeds from 20 to 30 tons. Now, my invention renders it possible to increase the diameter of the furnace, and therefore its production (or smelting capacity), more than twofold, without materially increasing the cost of construction, while the working expenses are reduced to a minimum. The second advantage arises from the peculiar construction of the hydrocycle, the elements or independent cells of which are fitted and united so as to render it possible for such to be cleaned while in place, or taken out and repaired while the furnace is in operation, with the least possible difficulty, and in the shortest length of time.

Referring to my drawings fig. 1, shows a perspective view of one of my ore-smelting furnaces. Fig. 2, vertical section on the line xx in fig. 3, which is itself a horizontal section, the upper part "1" on the line aa in fig. 2, and the lower part "2" on the line bb in fig. 2. Fig. 4 is an enlarged perspective of one of the cells of my water-jacket or hydrocycle and part of another cell, showing also the manner of their connection as well as of their construction. Fig. 5 is a vertical longitudinal section of the lower part of my furnace. Fig. 2^A is vertical section through centre of lead spout e .

A is the bottom of the furnace, and is made of fire-brick or fire-block. It rests on a cast-iron plate B, having a curl b . C C are cast-iron slabs, say, 6 feet in height, 3 feet in curvilinear breadth, and 2½ inches thick. These are bolted and clamped together at their upper ends, and further strengthened by having two strong circular iron bands c passed around them. These cast-iron slabs surround the masonry or fire-brick wall. Within the wall is the smelting hearth or crucible D of the furnace. This contains usually from 10 to 15 tons of hot lead, and is constructed of the usual refractory furnace material, viz., fire-brick, fire-clay, and "brasque" (clay and coke dust beaten together), out of which last material the upper surface of the crucible is moulded into a bowl shape, so as to hold the lead. A 2-inch hole e , figs. 2, 2^A, and 3, having a spout E at its upper and outer end, is drilled obliquely downward from the outside of the furnace, through the iron and the composition within, so as to strike the bottom of the bowl-shaped cavity, and through this the red hot lead rises, under the pressure of the charge and accumulating metal when the furnace is in action, till it runs out at the spout E, and is received in a pot placed beneath. One of the novelties in this lower part of the furnace or base is the working point F, the shape of which is obtained by drawing two tangents to the base of the extremities of its front quadrants, extending them until they meet, and then truncating the right angle formed at such a distance from the angle as will give a working front of about 3½ feet long projecting outward about 1 foot beyond the general curvature of the base. The general form thus obtained, though departing very little from that of a crucible, is much more convenient in use, the projecting front giving the extra depth required for working the furnace, and offering special facilities for affixing and changing the slag spout f , fig. 3, and speiss or matte spout f^1 . This peculiar form of working front is also advantageous in that it allows greater facility in bracing the entire wall, as the encircling strip curves to a better advantage and binds the whole in a better manner than if a straight projecting front were used. Resting upon the upper rim of the wall of fire-brick or fire-block which I have described is the hydrocycle, which I designate as an entirety by G. It consists of a series (nine, more or less) independent water-tight iron cells or compartments g of curvilinear form, locked rigidly together by means of bolts and cotters (in a manner presently to be described), so as to form an annular cellular trough through which the water circulates, entering under pressure near the bottom of each cell through pipes k from an encircling supply-pipe H above, and being discharged over the top edge of the outer side, each having a spout l leading into a launder or gretler I passing around the furnace. The special details of construction of the several segmental compartments of the hydrocycle, and the manner of bolting them together are as follows: Each segment is constructed of ½-inch boiler-plate, the sheet forming the inner walls being of the best flange-iron, capable of having its four edges turned back all round to the depth of 3 inches at least to receive the single piece which forms the front, sides, bottom-piece, and apron or top-piece g^1 , which latter is applied at a considerable slope towards the interior of the furnace, and only partly closes the top, whereby a space, say, 4 inches wide, and running the full length of the compartment, is left open for cleaning it out from time to time, and removing the fur which is apt to be deposited by the water. The several sheets are riveted together, so as to form a curvilinear segmental water-tight cell about 1 foot in diameter at the top, and tapering downwards to 8 inches at the bottom. Each segmental cell is provided with a T pipe coupling g^2 on the outside, by means of which a tubular connection k may be made between the cells, thus ensuring a constant, level, and free circulation of the water in and through the cells. Each cell is further provided with a pipe or spout l , through which the overflow or waste water is passed to the launder. In order to connect the several segmental cells together, and form a rigid trough or hydrocycle, a flat bar of iron m , about 3 inches wide and 1 inch thick, is bolted horizontally on the outer side of each, the ends of the bars being turned outward, say, 2 inches, at a right angle, and a hole made in each to receive an inch bolt m^1 , which is slotted to receive in its turn the "cotter" or wedged-shaped key m^2 (fig. 4). When these several cotters or wedges are driven home, the ends of all the short curved bars are forcibly drawn towards each other, and the bars united in a circle, which, tightening on the water compartments, locks them securely together, forming a rigid whole, the hydrocycle having the form of a frustum of an inverted hollow cone, the interior surface of which has a slope of about 1 in 8, corresponding to the general interior slope of the furnace. The cotters or bolts are removable at pleasure, so that each compartment of the hydrocycle can readily be detached and

Improvements in Ore-smelting Furnaces.

and withdrawn from its place (in case of its breaking or needing repairs), and another substituted for it without disturbing the rest, and without interfering with the working of the furnace. That compartment of the hydrocycle which faces the working front of the furnace does not extend downwards as far as the rest, a space of about 6 inches being left beneath it to allow of the occasional taking out of the scoriae from the interior. Moreover, this particular compartment, instead of resting on the masonry of the lower part of the furnace like the rest, is suspended between the adjoining ones at a slightly higher level by the two overflow spouts *o*, with which also it is provided, and by which also it discharges the waste water into the two adjoining compartments instead of out of the launder, which it is not found convenient to carry completely round the working front. Through certain of the cells of the hydrocycle are inserted the long blast tuyeres *P*, consisting of pipe, having a surrounding water-jacket *P'*, in which a constant circulation of water is maintained by means of the short pipes *p'* emptying their contents in the launder. These tuyeres project into the furnace 2 feet or more, or as far as the dotted circle in fig. 3, which may be taken as representing the sectional interior area of the circular blast furnace of average size, say, 36 inches in diameter. Through the remaining cells of the hydrocycle are let short blast tuyeres *q*, which do not project into the furnace at all. *RR*, fig. 3, are the blast-pipes, having their nozzles inserted in the open centres of the long tuyeres *P* and in the short tuyeres *q*. These are supplied with air under pressure from a wind chamber *S* above. For the short tuyeres *q* the water cells of the hydrocycle serve as water-jackets, so that they will not be burnt out. It will be perceived that the air entering the furnace through the long tuyeres *P* will be discharged within the area of the dotted circle, while that entering through the shorter ones *q* will be discharged within the curvilinear or annular space lying between the several pairs of long tuyeres and the sides of the hydrocycle. While, therefore, the former set of tuyeres supply air for the smelting of the portion of the charge lying within the area of the dotted circle, the latter set, opening decidedly on the inside of the several compartments, convey it to the portion lying within the curvilinear or annular spaces immediately in front of them, and thus the complete combustion of the fuel is insured over the whole area of the furnace, and the effect of two furnaces working as it were one inside of the other is produced. It will be readily seen from this that the capacity of any furnace is largely increased. It only remains to describe the shell *T* or upper portion of the furnace, which has the shape of a truncated inverted cone, and which rises about 12 feet above the hydrocycle with feed floor above, where it receives the ore and fuel (the charge), and is surrounded by a dome and stack leading to the flue, which part I have considered it unnecessary to show. The outer tunic or casing of the shell is of $\frac{3}{8}$ to $\frac{5}{8}$ of an inch in sheet-iron, and the lining of common brick, except for a distance of 2 feet from the bottom, where the shell takes a reverse slope (designated by *U*), to the top of the hydrocycle, and for this portion fire-bricks are used. The shell is supported indirectly by cast-iron pillars *V*, and no part of the weight is borne by the hydrocycle, which is left perfectly free, a space being left in which a layer of fire-brick *l* is supported upon the apron of the water-cells (fig. 5). The novelty to be noted about the upper part of the furnace is the wind-chamber *S*, which, instead of being made of galvanized iron or zinc, as is usual, and serving merely for the distribution of the blast, is made of iron-plate or stout sheet-iron or cast-iron, and converted into a hollow girder in sections of a right-angle triangle, which, encircling the shell beneath a flange *s*, receives its weight, and transfers it to the cast-iron pillars upon which it rests, and which rise from the foundation plate. By making a girder triangular instead of rectangular, sufficient strength is obtained with much less material. This girder wind-chamber receives the blast from a suitable blower through a 10-inch aperture, and distributes it to the blast pipes or tuyeres through pipes *r*, as before described. The water which is supplied to the tuyeres and hydrocycle becomes boiling hot, and usually deposits a considerable amount of calcium sulphates and carbonates on the inner surface, which tend to cause the iron to burn out, and hence the great importance of leaving the water-cells open at the top so that the deposits of "fur" from the water may be readily removed. The advantage gained by the reverse slope *U* of the shell is that it gives enlargement for the expansion of the gases from the charge, and more time is gained for their proper operation, as the ore is compact, but lower down the gases have a better opportunity to get at all the particles. The furnace thus far described is of a circular form of the diameter of 7 feet, and is capable of smelting from 50 to 60 tons of ore daily; but the principle explained by which the capacity is increased is applicable to the construction of a still larger furnace for retaining the diameter 7 feet (which has been found the most advantageous in practice), all that is necessary is to separate the two semicircles into which the plan of the hydrocycle may be supposed to be divided by a space, say, equal to the semi-diameter of the furnace or $3\frac{1}{2}$ feet, and then to introduce into the opening on either side a pair of additional cells of rectangular shape (not curvilinear) when the furnace will be converted into an oblong one with circular heads or ends, and a capacity of smelting from 80 to 100 tons daily, which is the capacity of one now in actual use, and which has even exceeded the production named.

Having thus described and explained the nature of my said improvements in ore-smelting furnaces, I would have it understood that what I claim as new, and of my invention is—

First—Constructing ore-smelting furnaces, the curved line wall *A* of which has a projecting working front *F*, formed by projecting two tangents to the circle of the base at the extremities of its front quadrant, extending them until they meet, and then truncating the right angle formed at a suitable distance from the angle, substantially as herein described and explained, and as illustrated in my drawings.

Second—In an ore-smelting furnace, an annular water-jacket or hydrocycle surrounding the region of fusion, said hydrocycle being constructed of independent and separately removable cells or compartments, substantially as herein described and explained, and as illustrated in my drawings.

Third—The means herein described for binding and clamping together the several cells of the hydrocycle into a rigid whole, and consisting of the bars *m*, the slotted bolts *m'*, and the cotters *m''*, substantially as herein described and explained.

Fourth—The means herein described for supplying said cells with water, and discharging it therefrom, the *T* coupling in the outer wall, the discharge spout over the top, and the encircling launder *I*, substantially as herein described and explained, and as illustrated in my drawings.

Fifth—

Improvements in Ore-smelting Furnaces.

Fifth—Making each said cell with an open or partially open top, whereby it may be cleaned of the "fur" left by the water, substantially as herein described and explained.

Sixth—So making my hydrocycle as that one of its cells is slightly raised above the adjoining ones, top and bottom, and discharges therein from its top in combination with the wall A upon which the hydrocycle rests, and having its working front and communications with the crucible under said specified section, substantially as and for the purposes herein described and explained, and as illustrated in my drawings.

Seventh—In an ore-smelting furnace having one set or series of blast tuyeres, and a diameter greater than twice the throw of the blast from said tuyeres, one or more sets or series of supplementary or additional blast tuyeres projecting within the furnace a sufficient distance to throw their blast into the spaces which lie near the centre or beyond the limits of the throw of the blast from the first set or series of tuyeres, substantially as herein described and explained.

Eighth—In an ore-smelting furnace, the shell T, having at its base a reverse slope U, just above the region of fusion, substantially as herein described and explained.

Ninth—In an ore-smelting furnace, the shell T, having a flange s in combination with the heavy surrounding wind-chamber S, triangular in cross-section, upon which the flange rests, and the pillars V supporting the wind-chamber, substantially as and for the purposes herein described and explained, and as illustrated in my drawings.

In witness whereof, I, the said Edward Probert, have hereto set my hand and seal, this day of one thousand eight hundred and eighty-four.

EDWARD PROBERT,

(By his Attorney, JOHN D. LA MONTE).

Witness—

CHARLES KAILLO, U.S. Consul.

—————

This is the specification referred to in the annexed Letters of Registration granted to Edward Probert, the twenty-ninth day of July, A.D. 1884.

AUGUSTUS LOFTUS.

REPORT.

Sir,

The Petition of Mr. Edward Probert, for Letters of Registration for an invention entitled "Improvements in Ore-smelting Furnaces," having been referred to us, we have examined the specification and drawings accompanying the same, and have now the honor to report that we see no objection to the granting of said Petition.

The Under Secretary of Justice.

Sydney, 18 June, 1884.

We have, &c.,

J. SMITH.

A. LEIBIUS.

[Drawings—one sheet.]

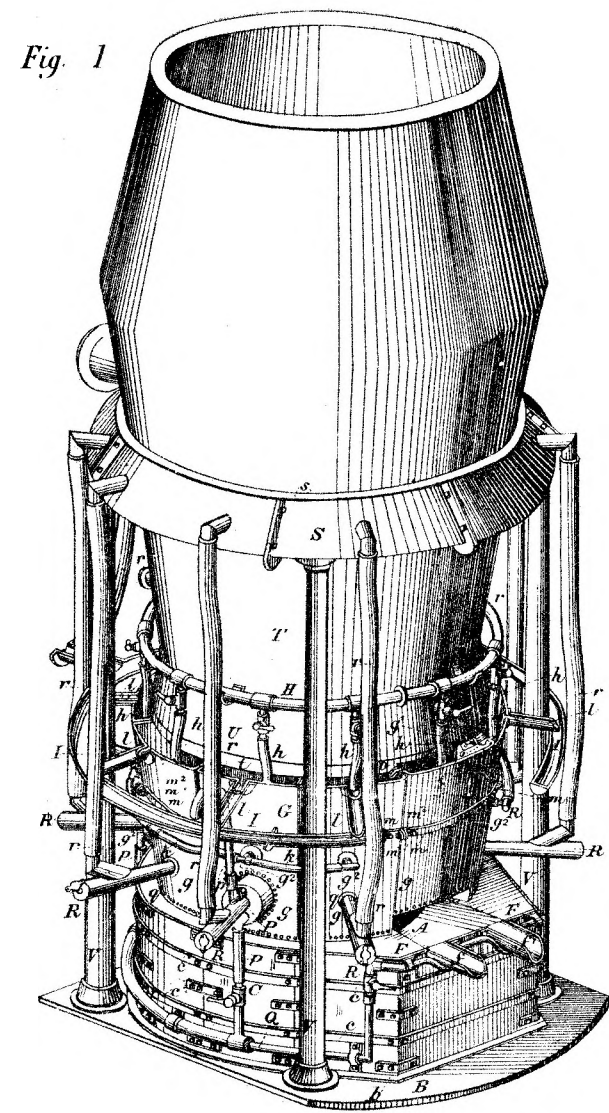


Fig. 1

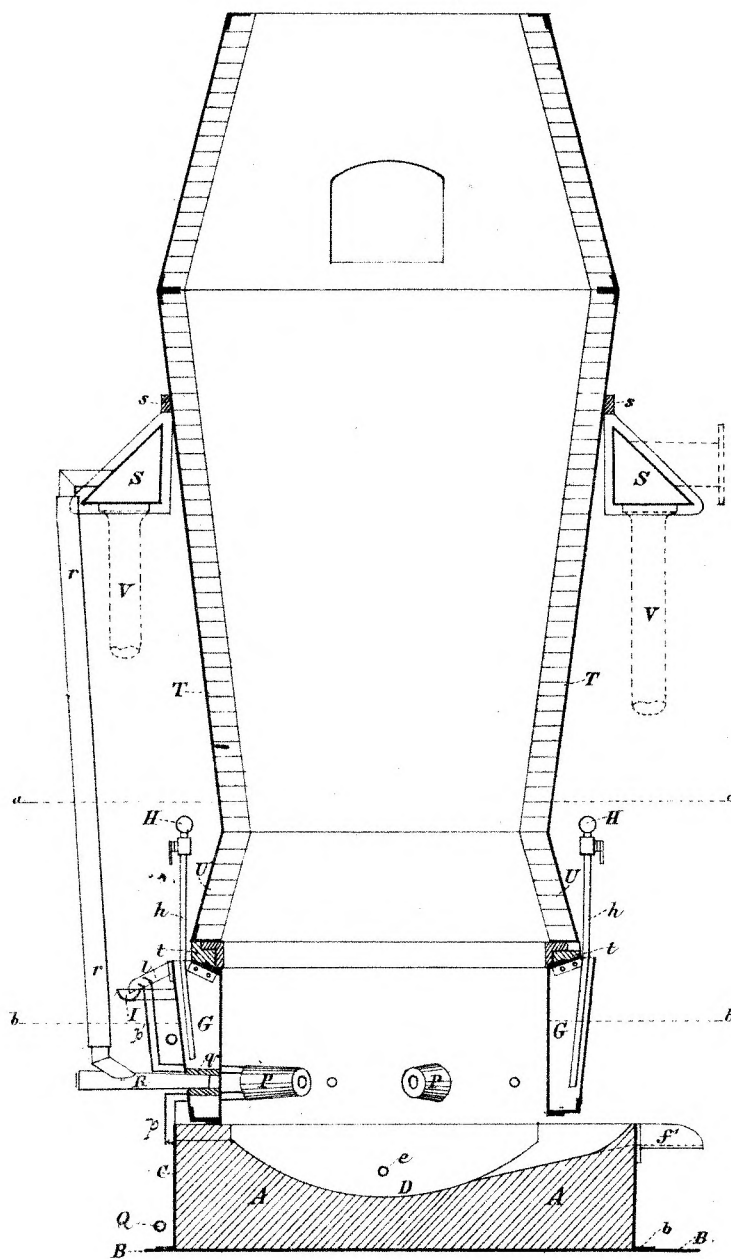


Fig. 2

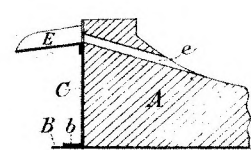


Fig. 2^A

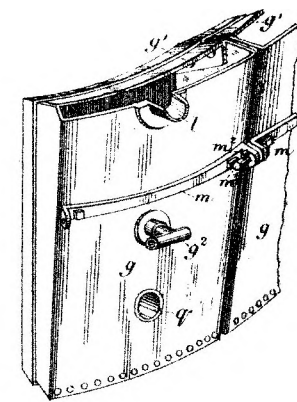


Fig. 4

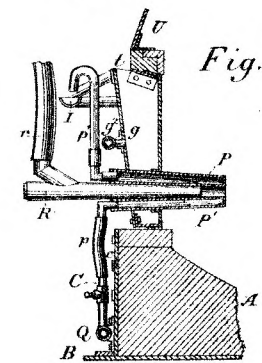


Fig. 5

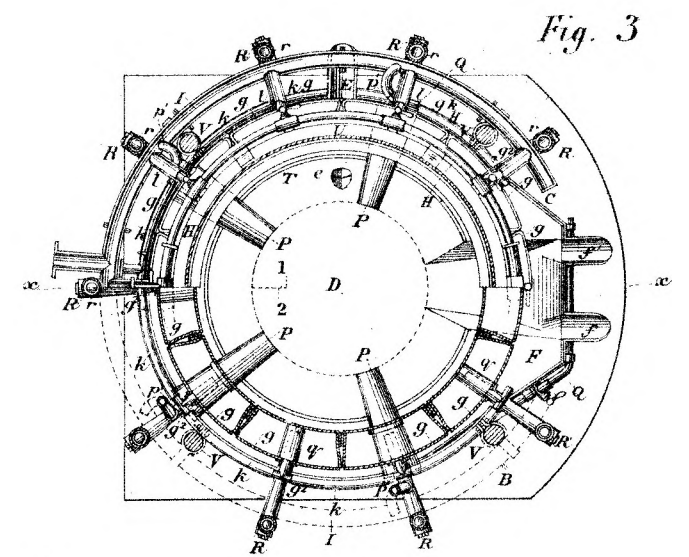


Fig. 3

This is the Sheet of Drawings referred to in the annexed Letters of Registration granted to Edward Probert, the twenty ninth day of July, A. D. 1884.

Augustus Loftus.



A.D. 1884, 30th July. No. 1470.

IMPROVEMENTS IN MACHINES FOR CONCENTRATING FINELY-DIVIDED
METALLIFEROUS MATERIAL.

LETTERS OF REGISTRATION to Joseph Carter, for Improvements in Machines
for concentrating finely-divided Metalliferous Material.

[Registered on the 31st day of July, 1884, in pursuance of the Act 16 Vic., No. 24.]

BY HIS EXCELLENCY THE RIGHT HONORABLE SIR AUGUSTUS WILLIAM FREDERICK SPENCER LOFTUS
(commonly called LORD AUGUSTUS LOFTUS), Knight Grand Cross of the Most Honorable Order of
the Bath, a Member of Her Majesty's Most Honorable Privy Council, Governor and Commander-in-
Chief of the Colony of New South Wales and its Dependencies.

TO ALL TO WHOM THESE PRESENTS SHALL COME, greeting:

WHEREAS JOSEPH CARTER, of Goulburn, in the Colony of New South Wales, engineer, hath
by his Petition humbly represented to me that he is the author or designer of a certain invention or
improvement in manufactures, that is to say, of an invention entitled "Improvements in Machines for
concentrating finely-divided Metalliferous Material," which is more particularly described in the speci-
fication and the sheet of drawings which are hereunto annexed; and that he, the said Petitioner, hath
deposited with the Honorable the Treasurer of the said Colony of New South Wales the sum of Twenty
Pounds sterling, for defraying the expense of granting these Letters of Registration, as required by the
Act of Council, sixteenth Victoria, number twenty-four; and hath humbly prayed that I would be pleased
to grant Letters of Registration, whereby the exclusive enjoyment and advantage of the said invention or
improvement might be secured to him for a period of fourteen years: And I, being willing to give
encouragement to all inventions and improvements in the arts or manufactures which may be for the
public good, and having received a report favourable to the prayer of the said Petition, from competent
persons appointed by me to examine and consider the matters stated therein and to report thereon for
my information, am pleased, with the advice of the Executive Council, and in exercise of the power and
authority given to me by the said Act of Council, to grant, and do by these Letters of Registration grant
unto the said Joseph Carter, his executors, administrators, and assigns, the exclusive enjoyment and
advantage of the said invention or improvement for and during the term of fourteen years from the date
hereof; to have, hold, and exercise unto the said Joseph Carter, his executors, administrators, and assigns,
the exclusive enjoyment and advantage thereof, for and during and unto the full end and term of fourteen
years from the date of these presents next and immediately ensuing, and fully to be complete and ended.
Provided always, that if the said Joseph Carter shall not, within three days after the granting of these
Letters of Registration, register the same in the proper office in the Supreme Court, at Sydney, in the
said Colony of New South Wales, then these Letters of Registration, and all advantages whatsoever
hereby granted, shall cease and become void.

In witness whereof, I have hereunto set my sign manual, and have caused the present Letters of
Registration to be sealed with the Seal of the said Colony of New South Wales, at Govern-
ment House, Sydney, in New South Wales, this thirtieth day of July, in the year of our
Lord one thousand eight hundred and eighty-four.

[L.S.]

AUGUSTUS LOFTUS.

Improvements in Machines for concentrating finely-divided metalliferous material.

SPECIFICATION of JOSEPH CARTER, of Goulburn, in the Colony of New South Wales, engineer, for an invention entitled "Improvements in Machines for concentrating finely-divided Metalliferous Material."

THIS invention consists of certain improvements in machines for concentrating finely-divided metalliferous material, and has especial reference to the invention forming the subject matter of Letters of Registration under the hand of the Governor, and seal of the Colony of New South Wales, dated the 4th day of January, 1884, granted to me for improvements in machines for concentrating finely-divided metalliferous material, and it has been designed to simplify the construction and working of a machine such as that described in the specification annexed to the said Letters of Registration.

My improvements consist, first, in a novel combination and arrangement of wheel or cam and rollers for giving the necessary motion to an inclined concentrating bed or surface; and, secondly, in the combination and arrangement with an inclined concentrating bed or surface of one or more sets of stirrers or harrows, for agitating the passing material.

In order that my invention may be clearly understood, I have illustrated a complete concentrating machine, as I prefer to use it, and with these, my further improvements attached. The main parts and the mode of working are similar to those described in the specification of my former invention before-mentioned, save that I now give the to-and-fro motion across the line of travel of the material in a much easier manner; that I use the same inclined bed or surface for concentrating either dry material, or material with the aid of water, which bed or surface I prefer should be that formed by the blanket and frame; and that I simplify other details, as may be easily understood on reference to the drawings. In the drawings (see figures 1 and 2) E^3 is a wheel on the main shaft E , which wheel is made preferably of wrought or malleable iron or steel, and has an indented curved circumference (as shown), to form on either side a cam rim E^4 . E^5 E^6 are friction rollers, one above and one below the cam rim E^4 , and two sets of these rollers are held in the jaw E^7 of the connecting rod E^1 to the bell crank F , from which motion is given to the "cradle" of the concentrating surface. It will be easily seen that when shaft E is revolved the rollers E^5 being held vertically in position follow the indentations of cam E^4 as it revolves, and thus raise and lower the connecting rod E^1 , and give motion to the concentrating surface. G are stirrers, or what I term "harrows," fixed to the stationary frame in series, just above the pockets or angles of the inclined concentrating surface. As the metalliferous material works downward over the inclined concentrating surface, which is moving to and fro while the "harrows" are fixed, these latter work up and agitate the material in such pockets, and give the lighter particles a chance to pass over the stops. Having thus particularly described and ascertained the nature of my said invention, and the manner in which the same is to be performed, I would have it understood that what I believe to be new, and therefore claim as my improvements in machinery for concentrating finely-divided metalliferous material, is—

First—The combination and arrangement on the shaft E of the wheel E^3 , having a curved circumference or cam E^4 , with one or two sets of friction rollers E^5 on the end of a connecting rod, to give motion to the concentrating surface, substantially as herein described and explained, and as illustrated in my drawings.

Second—The combination and arrangement with an inclined concentrating surface of one or more sets of stirrers or "harrows," substantially as and for the purpose herein described and explained.

JOSEPH CARTER.

Witness—

JAS. LANSETT,

Clerk to Betts & Carter, Goulburn.

This is the specification referred to in the annexed Letters of Registration granted to Joseph Carter, the thirtieth day of July, A.D. 1884.

AUGUSTUS LOFTUS.

REPORT.

Sir,

Sydney, 13 June, 1884.

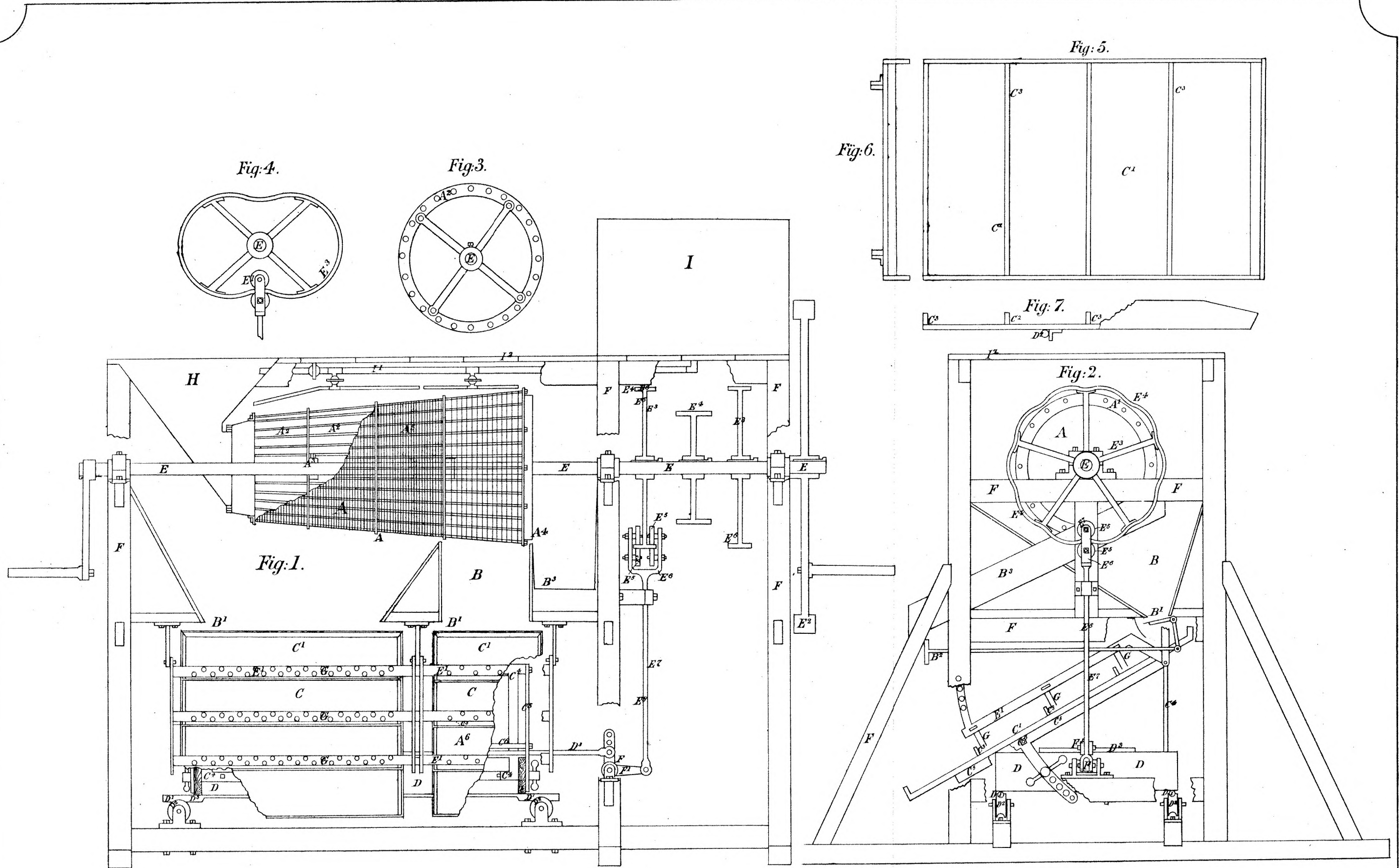
The petition of Mr. Joseph Carter, for Letters of Registration for an invention entitled "Improvement in Machines for concentrating finely-divided Metalliferous Material," having been referred to us, we have examined the specification and drawings accompanying the same, and have now the honor to report that we see no objection to the issue of Letters of Registration, as prayed for.

We have, &c.,

J. SMITH.

A. LEIBIUS.

The Under Secretary of Justice.



*This is the Sheet of Drawings referred to in the annexed Letters of Registration granted to Joseph Carter; the thirtieth day of July, A.D., 1884.
Augustus Loftus.*

Sig. 2-k5.



A.D. 1884, 30th July. No. 1471

OMEGA GAS-MAKING APPARATUS.

LETTERS OF REGISTRATION to William Hooker, for an invention entitled
"Omega Gas-making Apparatus."

[Registered on the 31st day of July, 1884, in pursuance of the Act 16 Vic. No. 24.]

BY HIS EXCELLENCY THE RIGHT HONORABLE SIR AUGUSTUS WILLIAM FREDERICK SPENCER LOFTUS
(commonly called LORD AUGUSTUS LOFTUS), Knight Grand Cross of the Most Honorable Order of the
Bath, a Member of Her Majesty's Most Honorable Privy Council, Governor and Commander-in-Chief
of the Colony of New South Wales and its Dependencies.

TO ALL TO WHOM THESE PRESENTS SHALL COME, greeting :

WHEREAS WILLIAM HOOKER, of Ada Villas, Erskineville Road, Newtown, in the Colony of New South Wales, gas engineer, hath by his Petition humbly represented to me that he is the author or designer of a certain invention or improvement in manufactures, that is to say, of an invention entitled "Omega Gas-making Apparatus," which is more particularly described in the specification and the sheet of drawings which are hereunto annexed ; and that he, the said Petitioner, hath deposited with the Honorable the Treasurer of the said Colony of New South Wales the sum of Twenty Pounds sterling, for defraying the expense of granting these Letters of Registration, as required by the Act of Council, sixteenth Victoria, number twenty-four ; and hath humbly prayed that I would be pleased to grant Letters of Registration, whereby the exclusive enjoyment and advantage of the said invention or improvement might be secured to him for a period of fourteen years : And I, being willing to give encouragement to all inventions and improvements in the arts or manufactures which may be for the public good, and having received a report favourable to the prayer of the said Petition, from competent persons appointed by me to examine and consider the matters stated therein and to report thereon for my information, am pleased, with the advice of the Executive Council, and in exercise of the power and authority given to me by the said Act of Council, to grant, and do by these Letters of Registration grant unto the said William Hooker, his executors, administrators, and assigns, the exclusive enjoyment and advantage of the said invention or improvement, for and during the term of fourteen years from the date hereof ; to have, hold, and exercise unto the said William Hooker, his executors, administrators, and assigns, the exclusive enjoyment and advantage thereof, for and during and unto the full end and term of fourteen years from the date of these presents next and immediately ensuing, and fully to be complete and ended : Provided always, that if the said William Hooker shall not, within three days after the granting of these Letters of Registration, register the same in the proper office in the Supreme Court, at Sydney, in the said Colony of New South Wales, then these Letters of Registration, and all advantages whatsoever hereby granted, shall cease and become void.

In witness whereof, I have hereunto set my sign manual, and have caused the present Letters of Registration to be sealed with the seal of the said Colony of New South Wales, at Government House, Sydney, in New South Wales, this thirtieth day of July, in the year of our Lord one thousand eight hundred and eighty-four.

[L.S.]

AUGUSTUS LOFTUS.

Omega Gas-making Apparatus.

KNOW all men by these presents that I, WILLIAM HOOKER, of No. 5, Ada Villas, off Erskineville Road, Newtown, in the Colony of New South Wales, gas engineer, claim as hereunder given "Improvements in Gas-making Apparatus," for which I desire a patent.

THE apparatus is called for distinctive purposes "The Omega Gas-making Apparatus." In it the well-known process of passing air over and through oil is adopted, but the salient points of this invention are given at the end of the following description of the apparatus, in which the cheap oil called spongaline or stove oil is used. It produces a good and rich gas, at a cheap rate, and the peculiar construction of the apparatus for the purposes of heating the oil, and delivering the gas from the material used, is insured in all weathers, and with perfect safety.

Fig. 1 shows a method of supplying air to the apparatus, which is an ordinary air-holder working in water with valve at the top for admitting air whilst being raised, which may be done by means of a cord passing over a pulley suspended over the holder. Other methods may be used for supplying current of air according to requirements of consumers.

Fig. 2 represents gas-making apparatus or generator, which is a box showing three trays DDD. Through each tray is a pipe *ddd* placed perpendicularly and at alternate ends of the trays. C shows gas-holder or governor. F represents hot-air tube passing through entire length of generator, which tube is encased in a larger tube, containing water, as shown by dots on plan. AAAA shows water-chambers back and front of the apparatus, being connected with each other by larger tube surrounding hot-air tube FE pipe from front hot-water chamber A, passing through generator to back hot-water chamber A, to allow surplus steam to escape, and forming a noticeable feature herein. H gas-pipe leading from generator to hot-air tube with Argand burner, as indicated on plan. K cock for gauging oil, as also shown on fig. 3. L plug for drawing off water from hot-water chamber. M cup for cleaning hot-air pipe. N plug for drawing off oil. *r* pipe leading from generator to side chamber R on fig. 3. S plug for supplying apparatus with oil. In supplying the apparatus with oil, the top tray first receives the oil, until it rises to level of top of perpendicular pipe *d*, when it overflows, and fills the tray underneath in like manner, and so on, until it rises at bottom of generator to level of gauge cock K. The air entering at P passes over oil at bottom of generator, and ascending, passes through perpendicular pipes *d* backwards and forwards over oil in trays, and thence in the form of gas to holder or governor C, from thence it passes into side chamber R in fig. 3, and thence to supply cock O leading to burners.

Fig. 3 represents front view of apparatus showing side chamber R.

Having thus described the nature and construction of my invention, and the peculiarities of the same, I would have it understood that I do not claim to be the inventor of the known process of passing air over or through mineral oil, neither do I confine myself to any particular shape of apparatus (although I believe the form adopted by me to be the best), but what I believe to be new, and therefore claim, are—

Firstly—The use of a hot-air pipe through the apparatus, which is supplied by means of an Argand burner at apparatus, thus keeping it at its proper temperature in *cold weather*, in which respect others fail.

Secondly—The use of water in the position surrounding the hot-air pipe, and thus doing away with all danger, also water-chamber front and back of the apparatus. The hot air passing through the pipe, heats the water, which also heats the air at back of the apparatus before passing into the generator of the apparatus, as substantially described and explained.

Thirdly—The combination of hot air and steam is claimed as new in this invention.

WILLIAM HOOKER,

5, Ada Villas, Erskineville Road, Newtown.

This is the specification referred to in the annexed Letters of Registration granted to William Hooker, the 30th day of July, A.D. 1884.

AUGUSTUS LOFTUS.

REPORT.

Sir,

The application of Mr. W. Hooker for Letters of Registration of an invention entitled "Omega Gas-making Apparatus" having been referred to us, we have examined the plans and specification accompanying the same, and have now the honor to report that we see no objection to the issue of Letters of Registration as prayed for.

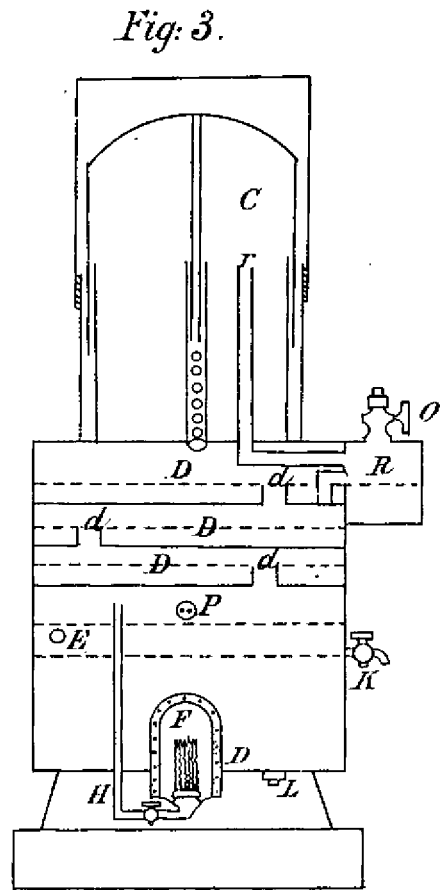
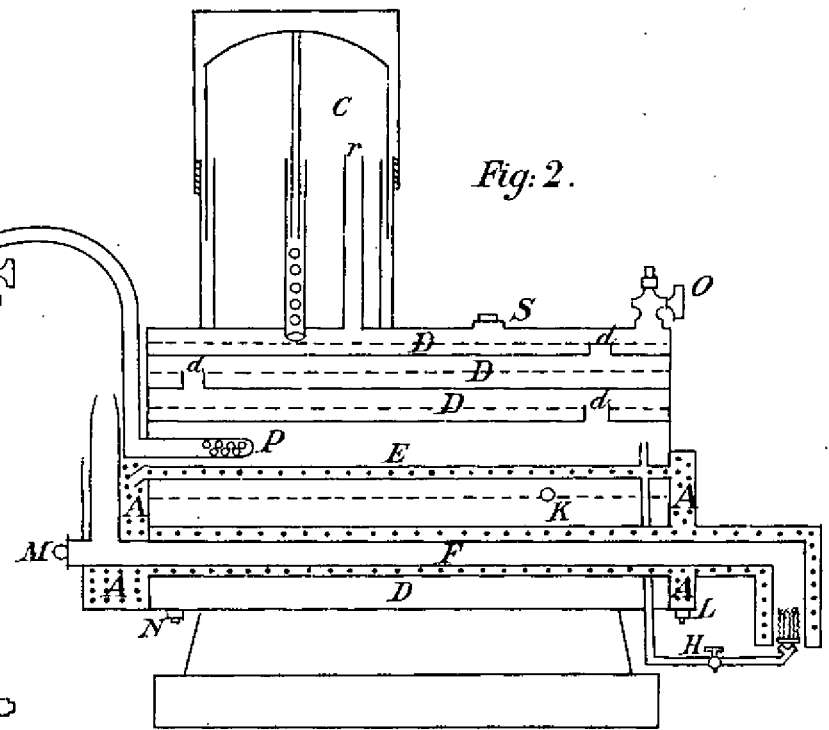
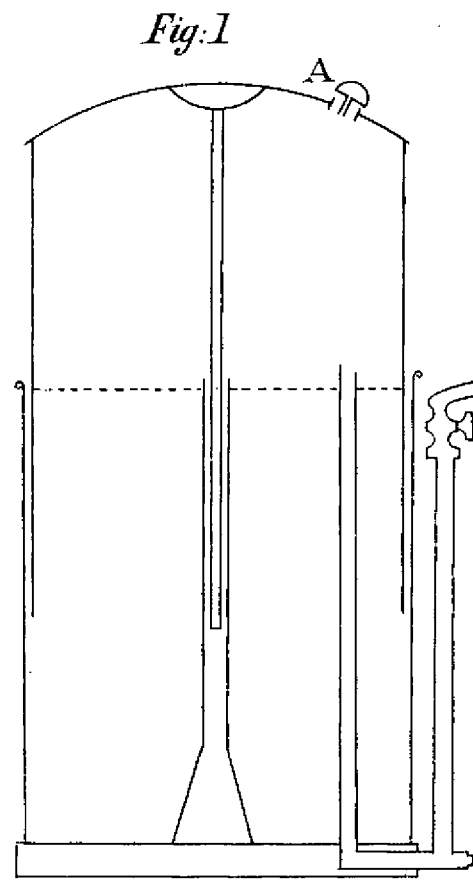
The Under Secretary of Justice.

Sydney, 6 June, 1884.

We have, &c.,

JAMES BARNET.

H. C. RUSSELL.



*This is the Sheet of Drawings referred to in the annexed Letters of Registration granted to William Hooker, the thirtieth day of July, A.D., 1884.
Augustus Loftus.*

William Hooker.

(Sig. 245.-)



A.D. 1884, 30th July. No. 1472.

PHILLIPS AND ANNETT'S TRANSVERSE IRON SLEEPER.

LETTERS OF REGISTRATION to George Phillips and Thomas Henderson Annett, for an invention entitled "Phillips and Annett's Transverse Iron Sleeper."

[Registered on the 31st day of July, 1884, in pursuance of the Act 16 Vic. No. 24.]

BY HIS EXCELLENCY THE RIGHT HONORABLE SIR AUGUSTUS WILLIAM FREDERICK SPENCER LOFTUS (commonly called LORD AUGUSTUS LOFTUS) Knight Grand Cross of the Most Honorable Order of the Bath, a Member of Her Majesty's Most Honorable Privy Council, Governor and Commander-in-Chief of the Colony of New South Wales and its Dependencies.

TO ALL TO WHOM THESE PRESENTS SHALL COME, greeting:

WHEREAS GEORGE PHILLIPS, of Sandgate, in the Colony of Queensland, and THOMAS HENDERSON ANNETT, of Lutwyche, in the said Colony of Queensland, civil servants, have by their Petition humbly represented to me that they are the authors or designers of a certain invention or improvement in manufactures, that is to say, of an invention entitled "Phillips and Annett's Transverse Iron Sleeper," which is more particularly described in the specification and the sheet of drawings which are hereunto annexed; and that they, the said Petitioners, have deposited with the Honorable the Treasurer of the said Colony of New South Wales the sum of Twenty Pounds sterling, for defraying the expense of granting these Letters of Registration, as required by the Act of Council, sixteenth Victoria, number twenty-four; and have humbly prayed that I would be pleased to grant Letters of Registration, whereby the exclusive enjoyment and advantage of the said invention or improvement might be secured to them for a period of fourteen years: And I, being willing to give encouragement to all inventions and improvements in the arts or manufactures which may be for the public good, and having received a report favourable to the prayer of the said Petition, from competent persons appointed by me to examine and consider the matters stated therein and to report thereon for my information, am pleased, with the advice of the Executive Council, and in exercise of the power and authority given to me by the said Act of Council, to grant, and do by these Letters of Registration grant unto the said George Phillips and Thomas Henderson Annett, their executors, administrators, and assigns, the exclusive enjoyment and advantage of the said invention or improvement, for and during the term of fourteen years from the date hereof; to have, hold, and exercise unto the said George Phillips and Thomas Henderson Annett, their executors, administrators, and assigns, the exclusive enjoyment and advantage thereof, for and during and unto the full end and term of fourteen years from the date of these presents next and immediately ensuing, and fully to be complete and ended: Provided always, that if the said George Phillips and Thomas Henderson Annett shall not, within three days after the granting of these Letters of Registration, register the same in the proper office in the Supreme Court, at Sydney, in the said Colony of New South Wales, then these Letters of Registration, and all advantages whatsoever hereby granted, shall cease and become void.

In witness whereof, I have hereunto set my sign manual, and have caused the present Letters of Registration to be sealed with the seal of the said Colony of New South Wales, at Government House, Sydney, in New South Wales, this thirtieth day of July, in the year of our Lord one thousand eight hundred and eighty-four.

[L.S.]

AUGUSTUS LOFTUS.

Phillips and Annett's Transverse Iron Sleeper.

DESCRIPTION of Phillips and Annett's Transverse Iron Sleeper.

THE details of this sleeper, as given in the annexed drawing, are designed for a 3' 6" gauge, but the principle is equally applicable to any gauge or description of rail.

Concisely, the principle sought to be patented, is that of a "transverse hollow iron sleeper, fitted with and holding suitable ballast, packed and rammed therein by means of ram-holes, one at each end of sleeper, and depending for support upon the natural compression of the vertical column below."

The method of attaching the rail to sleeper is purposely omitted as not forming any part of this patent.

The sleeper may be constructed of cast or wrought iron, but preferably of the latter, since its greater lightness in proportion to strength facilitates transport.

The sleeper, which is intended to be used transversely to the rails, is hollow, entirely open at bottom, rounded on top sides, lower sides slightly tapered outwards, ends rounded, without flanges or turned-up edges, and provided with a ram-hole at the upper part of each end or shoulder; the top is sufficiently flattened to afford the necessary support to rail.

In laying, the sleeper will be sunk about half its depth in the formation, the remaining half being packed with a cushion of sand, ashes, sawdust, clay, soil, or any suitable material, and tightly rammed by means of the ram-holes, no other ballast being requisite.

The advantages claimed for the sleeper are—

1. Economy in first cost of construction, where timber suitable for sleepers is not procurable or scarce.
2. Saving in ballast and the surface drainage necessary to protect same.
3. Saving in fencing and level crossings consequent thereon.
4. Facility and rapidity in laying lines in suitable country.
5. Facility in taking up and relaying lines laid for temporary purposes.
6. Economy in maintenance.
7. Increased comfort to travellers and less wear and tear of rolling stock, due to the perfectly even support afforded by the sleeper, and the elasticity of the road.

Brisbane, Queensland.

GEO. PHILLIPS.
T. H. ANNETT.

This is the specification referred to in the annexed Letters of Registration granted to George Phillips and Thomas Henderson Annett, the thirtieth day of July, A.D. 1884.

AUGUSTUS LOFTUS.

REPORT.

Sir,

Sydney, 4 June, 1884.

The application of Messrs. Phillips and Annett for Letters of Registration for an invention entitled "Transverse Iron Sleepers," having been referred to us, we have examined the plans and specification accompanying the same, and have now the honor to report that we see no objection to the issue of Letters of Registration as prayed for.

We have, &c.,

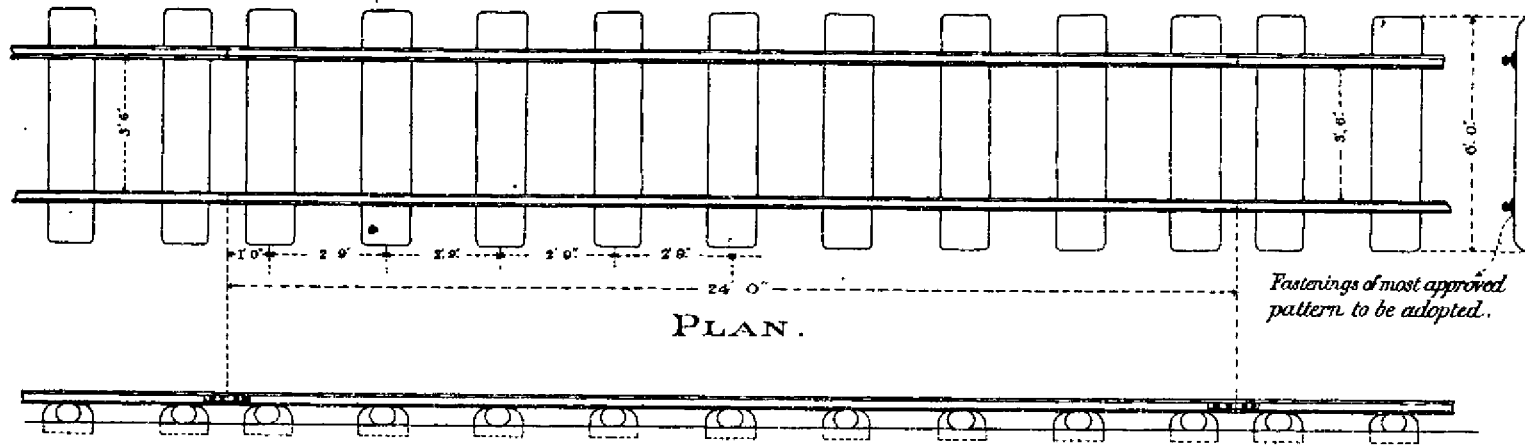
JAMES BARNET.
WILLIAM C. BENNETT.

The Under Secretary of Justice.

[Drawings—one sheet.]

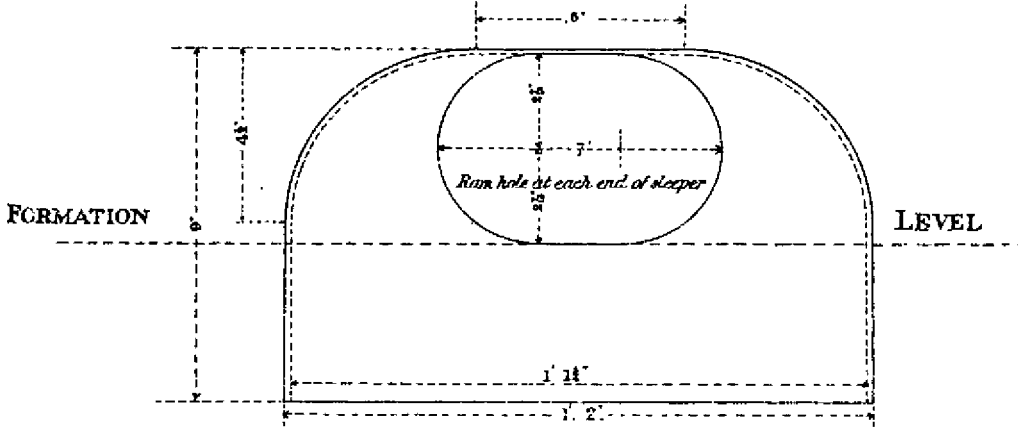
DETAILS OF PHILLIPS' & ANNETT'S TRANSVERSE IRON SLEEPER.

Scale of Feet



PLAN.

ELEVATION.



END ELEVATION OF SLEEPER.

Geo Phillips
JH Annett

This is the Sheet of Drawings referred to in the annexed Letters of Registration granted to George Phillips and Thomas Henderson Annett, the thirtieth day of July, A.D., 1864.
Augustus Loftus.

7.5 84



A.D. 1884, 6th August. No. 1473.

A COMBINED DEFLECTING AND INJECTING EXHAUST ROOF VENTILATOR AND CHIMNEY COWL.

LETTERS OF REGISTRATION to Richard Oakley for a Combined Deflecting and Exhaust Roof Ventilator and Chimney Cowl.

[Registered on the 6th day of August, 1884, in pursuance of the Act 16 Vic. No. 24.]

BY HIS EXCELLENCY THE RIGHT HONORABLE SIR AUGUSTUS WILLIAM FREDERICK SPENCER LOFTUS (commonly called LORD AUGUSTUS LOFTUS), Knight Grand Cross of the Most Honorable Order of the Bath, a Member of Her Majesty's Most Honorable Privy Council, Governor and Commander-in-Chief of the Colony of New South Wales and its Dependencies.

TO ALL TO WHOM THESE PRESENTS SHALL COME, greeting :

WHEREAS RICHARD OAKLEY, of 235, High Holborn, in the County of Middlesex, England, ventilating engineer, hath by his Petition humbly represented to me that he is the author or designer of a certain invention or improvement in manufactures, that is to say, of an invention entitled "A Combined Deflecting and Injecting Exhaust Roof Ventilator and Chimney Cowl," which is more particularly described in the specification and the sheet of drawings which are hereunto annexed ; and that he, the said Petitioner, hath deposited with the Honorable the Treasurer of the said Colony of New South Wales the sum of Twenty Pounds sterling, for defraying the expense of granting these Letters of Registration, as required by the Act of Council, sixteenth Victoria, number twenty-four ; and hath humbly prayed that I would be pleased to grant Letters of Registration, whereby the exclusive enjoyment and advantage of the said invention or improvement might be secured to him for a period of fourteen years : And I, being willing to give encouragement to all inventions and improvements in the arts or manufactures which may be for the public good, and having received a report favourable to the prayer of the said Petition from competent persons appointed by me to examine and consider the matters stated therein and to report thereon for my information, am pleased, with the advice of the Executive Council, and in exercise of the power and authority given to me by the said Act of Council, to grant, and do by these Letters of Registration grant unto the said Richard Oakley, his executors, administrators, and assigns, the exclusive enjoyment and advantage of the said invention or improvement for and during the term of fourteen years from the date hereof ; to have, hold, and exercise unto the said Richard Oakley, his executors, administrators, and assigns, the exclusive enjoyment and advantage thereof, for and during and unto the full end and term of fourteen years from the date of these presents next and immediately ensuing, and fully to be complete and ended : Provided always that if the said Richard Oakley shall not, within three days after the granting of these Letters of Registration, register the same in the proper office in the Supreme Court, at Sydney, in the said Colony of New South Wales, then these Letters of Registration, and all advantages whatsoever hereby granted, shall cease and become void.

In witness whereof, I have hereunto set my sign manual, and have caused the present Letters of Registration to be sealed with the seal of the said Colony of New South Wales, at Government House, Sydney, in New South Wales, this sixth day of August, in the year of our Lord one thousand eight hundred and eighty-four.

[L.S.]

AUGUSTUS LOFTUS.

A Combined Deflecting and Injecting Exhaust Roof Ventilator and Chimney Cowl.

SPECIFICATION of RICHARD OAKLEY, of 235, High Holborn, in the County of Middlesex, ventilating engineer, for an invention entitled "A Combined Deflecting and Injecting Exhaust Roof Ventilator and Chimney Cowl."

The Æolus Combined Deflecting and Injecting Exhaust Roof Ventilator and Chimney Cowl which I have invented are shown by the annexed drawings.

Fig. 1 is an elevation, and fig. 2 is a vertical section of the ventilator.

It consists of four or more triangular plates *a* of any material fixed to a frame of any material, the said plates sloping inwards and upwards, and of four or more other plates *b* of similar shape, sloping inwards and downwards, and of four or more other vertical triangular plates *c*, all the plates, whether horizontal or vertical, converging to a common centre, the four vertical plates forming, with the horizontal plates above and below, as many compartments; and of a tube, *d*, square or round, divided into four or more compartments, according to the number of compartments in the head above described. This tube descends vertically from the common centre, one compartment in the tube being in connection with a corresponding compartment in the head. This tube is closed at the bottom, excepting a small opening with a very small pipe *e* attached in the form of a letter ∞ at the bottom of same to carry off water driven in at the common centre, and excepting two nozzles *f*, of an inch or more or less in diameter, fixed in the side of each such compartment of the descending tube. These nozzles discharge the air driven down from the head in an upward direction into the main shaft *g*. The said head and descending tube are fixed in a main shaft *g*, which may be three or four times the diameter of the descending shaft *d*. The shaft *g* is left open below for the vitiated air of the building to which it is attached to escape by, and is open at the top also, but is at the top at a certain distance, say 5 inches or more, according to the size of the instrument, connected by stays with the head, consisting of the plates *a*, *b*, *c*, as above described. Furthermore, in order to protect this open space from the entrance of external air, and to facilitate the outcome of the vitiated air, it is surrounded by four circular deflecting guards H^1 , H^2 , H^3 , H^4 above, and four marked h^1 , h^2 , h^3 , h^4 below, with one double central guard H^4 , h^4 , common to both top and bottom. These guards may be made of any material, and of any depths from 1 inch to 6 inches each. The first of the upper guards H^1 is attached to the base of the head above described, and is intended to deflect a current entering at the top; it is set at any angle less than a right angle, and the other three guards at a similar angle, or even less angle, than the first, a distance of at least half an inch, being preserved between each guard. The central double guard appears between the outside upper and lower guards, and the angle edge of it is flush with the opening of those two outside guards. A side wind striking on this is deflected both upwards and downwards, and passes through the upper and lower inner guards. The first lower guard h^1 is attached to the top of the main shaft, from which it slopes upwards at any angle less than a right angle; the other lower guards preserve the same relative distances to the first lower guard as the other upper guards do to the first upper guard aforesaid, and are set at corresponding angles. The object of the lower guards is to deflect currents from below, and turn them upwards, so as to pass between the upper guards. The special feature of this ventilator is the combination of the two systems of deflection and injection.

By a modification of this invention it can be used as a chimney cowl. The modified arrangement is represented in elevation by figure 3, and figures 4 and 5 are vertical sections of the same. In this case the four injection tubes *i*, *i*, *i*, *i* are brought down outside the shaft *k*, and enter a few inches above the base. These tubes are trumpet-mouthed at the top at *i*¹, and turn upwards at the bottom into the shaft. A simple cone *l* protects the mouth of the shaft deflecting a down current, and one guard *m* attached to the mouth of the main shaft deflects an up-current. Over these two deflecting surfaces, and at a distance of two or more inches from them, and at the same angle, is placed an outer guard *o*, sloping up above the cone upwards and down to the main shaft downwards. Into this latter division of the guards the trumpet-mouths of the injection tubes run. The angle of these guards is set exactly opposite the centre of the space between the base of the cone and the edge of the guard, at top of the main shaft, and deflects a horizontal current. An additional guard may also with advantage be applied at *p*, to deflect any current formed by rebound from the internal angle of the guard *o*. This cowl may also be made without the outer guards around the head.

What I claim is the Æolus Combined Deflecting and Injecting Exhaust Roof Ventilator, substantially as described.

I also claim the modifications thereof adapting it as a chimney cowl.

In witness whereof, I, the said Richard Oakley, have hereto set my hand and seal, this seventeenth day of June, one thousand eight hundred and eighty-four.

RICHARD OAKLEY,

(By his Agent, BASIL G. WOOLLEY.)

Witness—

FRED WALSH, Mgr., Edwd. Waters' Patent Office, Sydney.

This is the specification referred to in the annexed Letters of Registration granted to Richard Oakley, the sixth day of August, A.D. 1884.

AUGUSTUS LOFTUS.

REPORT.

Sir,

The application of Mr. Richard Oakley for Letters of Registration for an invention entitled "A Combined Deflecting and Injecting Exhaust Roof Ventilator and Chimney Cowl," having been referred to us for report, we have examined the plans and specifications accompanying the same, and are of opinion that the prayer of the Petition might be granted.

We have, &c.,

JAMES BARNET.

WILLIAM C. BENNETT.

The Under Secretary of Justice.

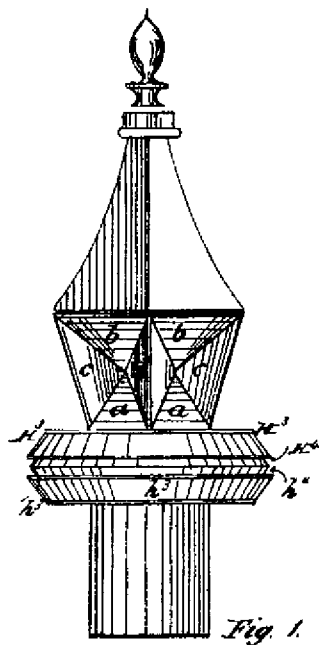


Fig. 1.

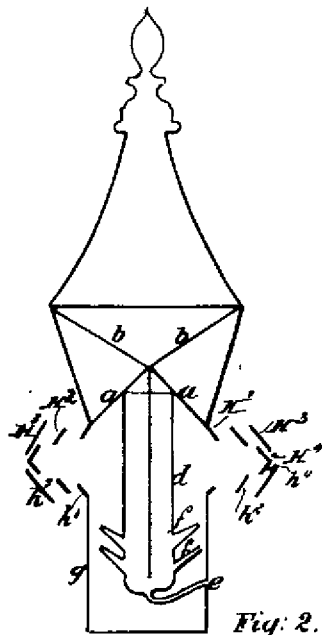


Fig. 2.

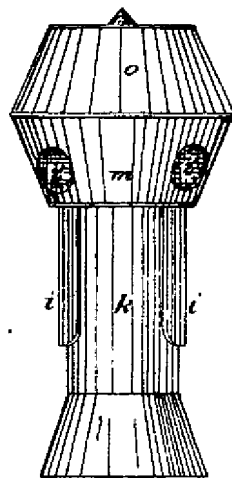


Fig. 3.

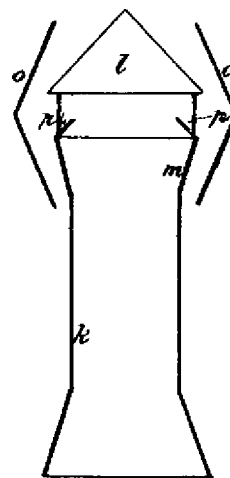


Fig. 4.

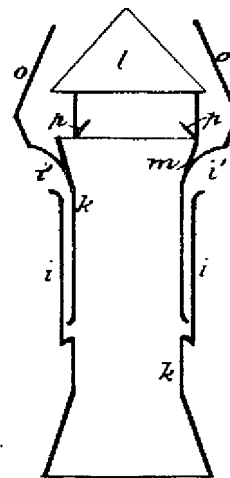


Fig. 5.

*This is the Sheet of Drawings referred to in the annexed
Letters of Registration granted to Richard Outley,
the sixth day of August, AD 1884.*

Augustus Johns.

PHOTO-LITHOGRAPHED AT THE GOVT. PRINTING OFFICE,
SYDNEY, NEW SOUTH WALES.

(Sig 245-)



A.D. 1884, 6th August. No. 1474.

THE SELF-ACTING WIRE FENCE.

LETTERS OF REGISTRATION to George Edwards for The Self-acting Wire Fence.

[Registered on the 6th day of August, 1884, in pursuance of the Act 16 Vic. No. 24.]

BY HIS EXCELLENCY THE RIGHT HONORABLE SIR AUGUSTUS WILLIAM FREDERICK SPENCER LOFTUS (commonly called LORD AUGUSTUS LOFTUS), Knight Grand Cross of the Most Honorable Order of the Bath, a Member of Her Majesty's Most Honorable Privy Council, Governor and Commander-in-Chief of the Colony of New South Wales and its Dependencies.

TO ALL TO WHOM THESE PRESENTS SHALL COME, greeting :

WHEREAS GEORGE EDWARDS, of Wybong, near Muswellbrook, in the Colony of New South Wales, hath by his Petition humbly represented to me that he is the author or designer of a certain invention or improvement in manufactures, that is to say, of an invention entitled "The Self-acting Wire Fence," which is more particularly described in the specification and the sheet of drawings which are hereunto annexed ; and that he, the said Petitioner, hath deposited with the Honorable the Treasurer of the said Colony of New South Wales the sum of Twenty Pounds sterling, for defraying the expense of granting these Letters of Registration, as required by the Act of Council, sixteenth Victoria, number twenty-four ; and hath humbly prayed that I would be pleased to grant Letters of Registration, whereby the exclusive enjoyment and advantage of the said invention or improvement might be secured to him for a period of fourteen years : And I, being willing to give encouragement to all inventions and improvements in the arts and manufactures which may be for the public good, and having received a report favourable to the prayer of the said Petition, from competent persons appointed by me to examine and consider the matters stated therein and to report thereon for my information, am pleased, with the advice of the Executive Council, and in exercise of the power and authority given to me by the said Act of Council, to grant, and do by these Letters of Registration grant unto the said George Edwards, his executors, administrators, and assigns, the exclusive enjoyment and advantage of the said invention or improvement, for and during the term of fourteen years from the date hereof ; to have, hold, and exercise unto the said George Edwards, his executors, administrators, and assigns, the exclusive enjoyment and advantage thereof, for and during and unto the full end and term of fourteen years from the date of these presents next and immediately ensuing, and fully to be complete and ended : Provided always, that if the said George Edwards shall not, within three days after the granting of these Letters of Registration, register the same in the proper office in the Supreme Court, at Sydney, in the said Colony of New South Wales, then these Letters of Registration, and all advantages whatsoever hereby granted, shall cease and become void.

In witness whereof, I have hereunto set my sign manual, and have caused the present Letters of Registration to be sealed with the seal of the said Colony of New South Wales, at Government House, Sydney, in New South Wales, this sixth day of August, in the year of our Lord one thousand eight hundred and eighty-four.

AUGUSTUS LOFTUS.

The Self-acting Wire Fence.

SPECIFICATION of "Self-acting Wire Fence" for rivers and creeks.

THE timber used in the erection of the fence should be of the best quality of split hardwood, except the lever, which should be pine, or any strong light wood.

The fence must always be erected some distance below a curve, as the accumulation of timber, as well as sandbanks, are always greater there.

Main posts A.

The main posts marked A should be round and solid, 5' 6" high and 12" diameter. The distance required to be driven must depend on the nature of the ground, but I would strongly recommend them to be well driven, as there will be a great strain on them sometimes, according to the strength of the flood and width of river or creek.

Dog-hooks B.

The dog-hooks marked B should be 3' long by 1½" round iron, and made according to the model, which should be secured by a strong eye-bolt made of 1" round iron, with a square shoulder to prevent its turning, passing through the posts 4" from the top and a little inside of the centre, and fastened by a nut. Plenty of room must be given for the dog-hooks to work free; the size or strength of the iron must be, in a great measure, according to the width of river or creek, as reason must dictate; the wider it is, the more strength is required. The dog-hooks should not have any more than 1½" hold in the fastening marked D.

Block C.

As the main posts will be round, it will be necessary to have a block, marked C, of sound dry timber, 1' 6" long, 1' wide, and 4½" thick, let into the posts 3½", for the fastening marked D to work on; the block must be securely bolted to the main post by two ¾" bolts, let in flush with the block, the top of block to be 3" from top of post; there must be an iron plate 2" × ¼" screwed on the block C for the fastening marked D to work against; also, near the end of the fastening, marked D, there must be a flat staple to keep it in its place, similar to the latch of a door, which can be screwed on the block C.

Fastening D.

The fastening marked D should be a piece of flat iron, 2½" × ¾", and 1' long, measured from the bolt-hole, and at the end there must be an eye the whole depth of the iron, 2½", sufficiently large as to admit *easily* the end of the dog-hook marked B, and at the end of the fastening, and on the under side, there must be a strong eye made to receive the bar marked J; the round bolt which secures the fastening marked D to the block C should be ½ of an inch, the head of the bolt to be placed *inside* of the block C to allow the fastening to be easily removed if required.

Lever post E.

The lever post marked E should be round, and not less than 9" diameter, with a slot of 9" × 4" on the top for the lever to work in; a ½" bolt will be required for the lever to work on. The depth to be driven, like the main posts, must depend on the nature of the ground; the distance between the lever post marked E and the main post marked A should be 1'.

Lever stop.

The lever stop marked F should be driven into the ground a sufficient depth, near the oil drums, to have a firm hold, if not, the oil drums attached to the levers will rise with the flood and be carried away. The posts should be say 6" × 4", and the cross-head should be let into the posts, as shown in plan, and bolted together with two ½" bolts; the cross-head should be so placed as not to allow the oil drums attached to the levers to rise more than than 2', as shown in plan; the distance between the two posts should be 4½"; that will allow ½" play for the lever.

Oil drums, G1 and G. 2.

The oil drum marked G, attached to the lever, represents the position of lever resting on log K before a flood; the oil drum marked G 2, attached to the lever with *dotted line*, and connected with the fastening marked D, with *dotted line*, represents the position caused by a flood. As it will be seen by the plan, when a flood comes, the lever attached to the oil drum rises to the height of stop marked F, which causes the fastening marked D, dotted line, to drop below the point of dog-hook marked B, when, all being free, the fence falls to the bottom by the force of the current. Great care must be taken to *securely stop* the bung-holes of the oil drums; the oil drum, containing 5 gallons, will be equal to a power of 525 lb. at the fastening marked D.

Safety rod H.

It would be better to fix the oil drums *under* the levers, instead of the *top*, as shown in the plan, to prevent any drift timber coming in contact with them.

This safety rod, marked H, should be 1½" of round iron driven securely into the main post at the top of block marked C; it should incline upwards and outwards, and of sufficient length (say 1 foot) that will allow the fence to fall just clear of the point of the rod. It is necessary to have this rod to prevent the dog-hook marked B from getting inside of the post of the fence when falling.

Lever I.

The lever marked I should be made of some strong light wood according to the model; the length should be 6' from the end where the oil drum is fixed to the bolt-hole in the lever post marked E, and from the bolt hole in lever post, marked E, to the bolt hole at end of the lever should be 1', making the total length of lever 7'. The levers should be 4" × 3½", and at the end near the main post there should be an iron cleat on each side to strengthen it, with a hole to admit of a ½ bolt. At the end of lever, where the oil drum is fixed, it will be necessary to bolt two pieces, one on each side, the same size as the lever, and 1' 6" long, slightly hollowed out for the oil can to bed in.

Bar J.

The bar marked J which connects the fastening, marked D, should be made of bar iron, say 1' long, 2" × ½", and pierced with a double line of holes for a ½ bolt, these holes to be pierced alternately with each other, which will allow the lever to be regulated, as required; the bar J and the fastening D can be made connected, or in two parts.

Log K.

The log marked K, about 5' long and 1' in diameter, with a 6" face for the point of lever to rest on, should be let into the ground crossways with the lever. At the same time care must be taken to have both logs marked K level with each other, so that both dog-hooks marked B should open at the same time. If there are any old stumps or trees suitable they may be used in the place of the logs.

Fence.

In the plan for the fence there are only two pannels shown with four wires: the number of pannels must be according to the width of river or creek, and the number of wires also must be according to the kind of fence required. If for sheep more wires can be added. The fence, as shown in the plan, is not drawn to *any particular scale*, but it will be found necessary to erect the fence in pannels, say in 40' lengths, the posts to be about 13' 6" distant from each other, and a vacancy of 6" between the pannels, and connected, as in plan marked L, by 2" × ¾" iron. The post through which the bolt goes should have a cleat of stout iron-hoop to prevent the head from splitting; the inside or up-stream side of fence should be erected in a line with the outside or down-stream side of the main posts marked A. The short posts must be firmly driven into the ground, and not standing more than 3" above the surface. These posts, I think

The Self-acting Wire Fence.

think, will be best split from a tree about 9" diameter, so that each length will make two posts. The hinges most suitable for a fence of this description will be a $\frac{3}{4}$ " eye-bolt to go through the short posts; the other part, which is bolted by two $\frac{5}{8}$ " bolts on the long posts, should be 9" long by 2" \times $\frac{5}{8}$ ", with a *large oval eye* at the bottom, as shown in plan. Attention must be paid to this, as it will be found necessary for the hinges to work *freely*, to have plenty of room to allow the fence to fall; the long posts must be cut square, and rest firmly on the short posts. The chains which secure the fence to the dog-hooks marked B should be made of $\frac{3}{4}$ " iron and round links, except the large links, which the dog-hooks marked B work in. They should be of an oval shape, taking great care sufficient room is given for the dog-hooks to work freely.

The fence, as shown in plan, is more suitable for rivers and creeks where the surface or bed is somewhat of an uniform level, but the *same fence can be as easily erected* in any river or creek, however abruptly its bed or surface may rise, by a slight alteration in the levers. In fact, it can be erected to any extent on flooded lands as well, by a slight alteration of the levers, as circumstances may require.

GEO. EDWARDS.

This is the specification referred to in the annexed Letters of Registration granted to George Edwards, the sixth day of August, A.D. 1884.

AUGUSTUS LOFTUS.

REPORT.

Sir,

Sydney, 26 June, 1884.

The application of Mr. George Edwards for Letters of Registration for an invention entitled "Self-acting Wire Fence," having been referred to us for report, we have examined the plans and specification accompanying the same, and are of opinion that the prayer of the Petition may be complied with.

We have, &c.,

JAMES BARNET.

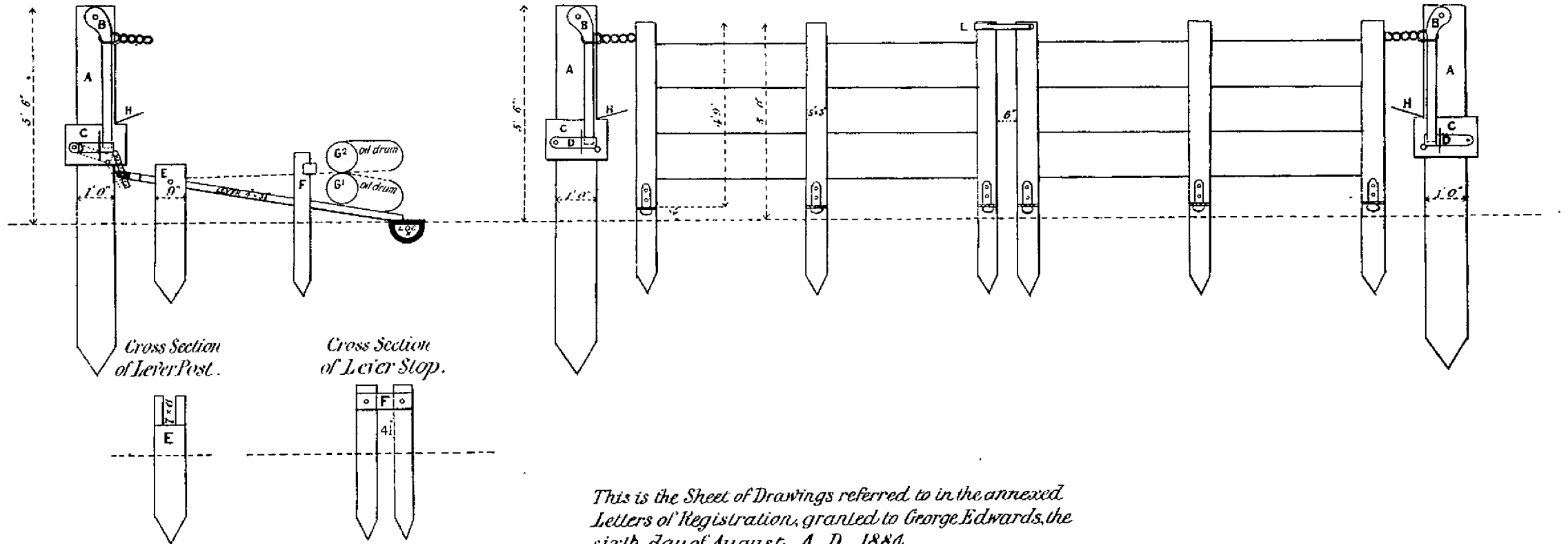
WILLIAM C. BENNETT.

The Under Secretary of Justice.

[Drawings—one sheet.]

PLAN OF SELF ACTING FENCE.

Scale of Feet
0 1 2 3 4 5 6



This is the Sheet of Drawings referred to in the annexed Letters of Registration, granted to George Edwards, the sixth day of August, A. D., 1884.

Augustus Loftus.

(Sig: 245)



A.D. 1884, 6th August. No. 1475.

A PRESERVATION FOR PRESERVING PILES AND WOODWORK.

LETTERS OF REGISTRATION to Samuel Henry Stockton, for a preparation for preserving piles and any woodwork immersed or to be immersed in salt-water from the ravages of worms and other marine animals, and the mode of its application.

[Registered on the 6th day of August, 1884, in pursuance of the Act 16 Vic. No. 24.]

BY HIS EXCELLENCY THE RIGHT HONORABLE SIR AUGUSTUS WILLIAM FREDERICK SPENCER LOFTUS (commonly called LORD AUGUSTUS LOFTUS), Knight Grand Cross of the Most Honorable Order of the Bath, a Member of Her Majesty's Most Honorable Privy Council, Governor and Commander-in-Chief of the Colony of New South Wales and its Dependencies.

TO ALL TO WHOM THESE PRESENTS SHALL COME, greeting :

WHEREAS SAMUEL HENRY STOCKTON, of St. John, New Brunswick, Dominion of Canada, in America, at present in Sydney, in the Colony of New South Wales, master mariner, hath by his Petition humbly represented to me that he is the author or designer of a certain invention or improvement in manufactures, that is to say, of an invention entitled "A preparation for preserving piles and any woodwork immersed or to be immersed in salt-water from the ravages of worms and other marine animals, and the mode of its application," which is more particularly described in the specification and the sheet of drawings which are hereunto annexed; and that he, the said Petitioner, hath deposited with the Honorable the Treasurer of the said Colony of New South Wales the sum of Twenty Pounds sterling, for defraying the expense of granting these Letters of Registration, as required by the Act of Council, sixteenth Victoria, number twenty-four; and hath humbly prayed that I would be pleased to grant Letters of Registration, whereby the exclusive enjoyment and advantage of the said invention or improvement might be secured to him for a period of fourteen years: And I, being willing to give encouragement to all inventions and improvements in the arts or manufactures which may be for the public good, and having received a report favourable to the prayer of the said Petition, from competent persons appointed by me to examine and consider the matters stated therein and to report thereon for my information, am pleased, with the advice of the Executive Council, and in exercise of the power and authority given to me by the said Act of Council, to grant, and do by these Letters of Registration grant unto the said Samuel Henry Stockton, his executors, administrators, and assigns, the exclusive enjoyment and advantage of the said invention or improvement, for and during the term of fourteen years from the date hereof; to have, hold, and exercise unto the said Samuel Henry Stockton, his executors, administrators, and assigns, the exclusive enjoyment and advantage thereof, for and during and unto the full end and term of fourteen years from the date of these presents next and immediately ensuing, and fully to be complete and ended: Provided always, that if the said Samuel Henry Stockton shall not, within three days after the granting of these Letters of Registration, register the same in the proper office in the Supreme Court, at Sydney, in the said Colony of New South Wales, then those Letters of Registration, and all advantages whatsoever hereby granted, shall cease and become void.

In witness whereof, I have hereunto set my sign manual, and have caused the present Letters of Registration to be sealed with the seal of the said Colony of New South Wales, at Government House, Sydney, in New South Wales, this sixth day of August, in the year of our Lord one thousand eight hundred and eighty-four.

[L.S.]

AUGUSTUS LOFTUS.

A Preparation for Preserving Piles and Woodwork.

SPECIFICATION of SAMUEL HENRY STOCKTON, of St. John, New Brunswick, Dominion of Canada, in America, master mariner, for an invention or an improvement in the arts and manufactures, entitled "A preparation for preserving piles or any other woodwork immersed or to be immersed in salt-water from the ravages of worms and other marine animals, and the mode of its application."

THE following is my preparation:—A mixture of petroleum oil, spirits of turpentine, or other penetrating oil, arsenic, and strychnine, in the following proportions, namely, one gallon of oil, one-half pound of arsenic, and one ounce of strychnine.

And my mode of preparing the piles or woodwork for its application and of its application is as follows:—

I drive the pile or woodwork, small end downwards, into its proper position, with the top sawn straight and with its bark on, in an undressed state, or dressed in such a way as will not break or interfere with the continuity of its fibres or grain. I then bore or cut a hole or opening, say, 3 feet deep in the centre of the top thereof, and from the same hole or opening I cut four or more channels or openings to the side or edge of the pile or woodwork, but not cutting same right through, such channels or openings tapering to a fine point at such side or edge, as is shown on the diagrams herewith marked A and B; or, in lieu thereof, I bore four or more holes, each not less than one-quarter of an inch in diameter, round the outside of such pile or woodwork, and extending to or meeting at the core or centre thereof on a position on it above high-water mark, in manner and as is shown on diagram C herewith. The preparation should be applied daily by filling the hole or opening at top of the pile or woodwork or by filling the holes on the side thereof above high-water mark for six weeks, at end of which time the wood will become thoroughly saturated, or it should be applied for a further time until the wood has become saturated, after which an application about once a week, according to the closeness or texture of the grain of the wood, will suffice.

By the preparation permeating the wood from above the part which would be above high-water mark, by or through the fibre or grain of the wood, the pile or woodwork will be rendered thoroughly poisoned and totally impervious to the ravages of worms and other marine animals.

The advantages of my preparation, and its application, are its extreme cheapness and simplicity in management, for it is only necessary, after the timber is once saturated, to refill the holes or openings daily, thus avoiding the constant renewal of the piles or woodwork or of sheathing or other preventative methods at present applied thereto in such cases.

S. H. STOCKTON.

Signed, sealed, and delivered by the said
Samuel Henry Stockton, in the presence of,—
J. ARTHUR DOWLING,
Solicitor, Sydney.

This is the specification referred to in the annexed Letters of Registration granted to Samuel Henry Stockton, this sixth day of August, A.D. 1884.

AUGUSTUS LOFTUS.

REPORT.

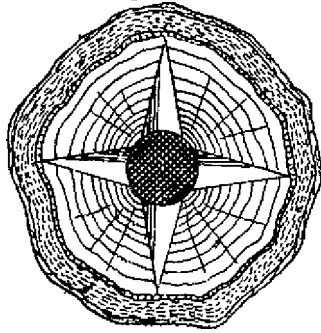
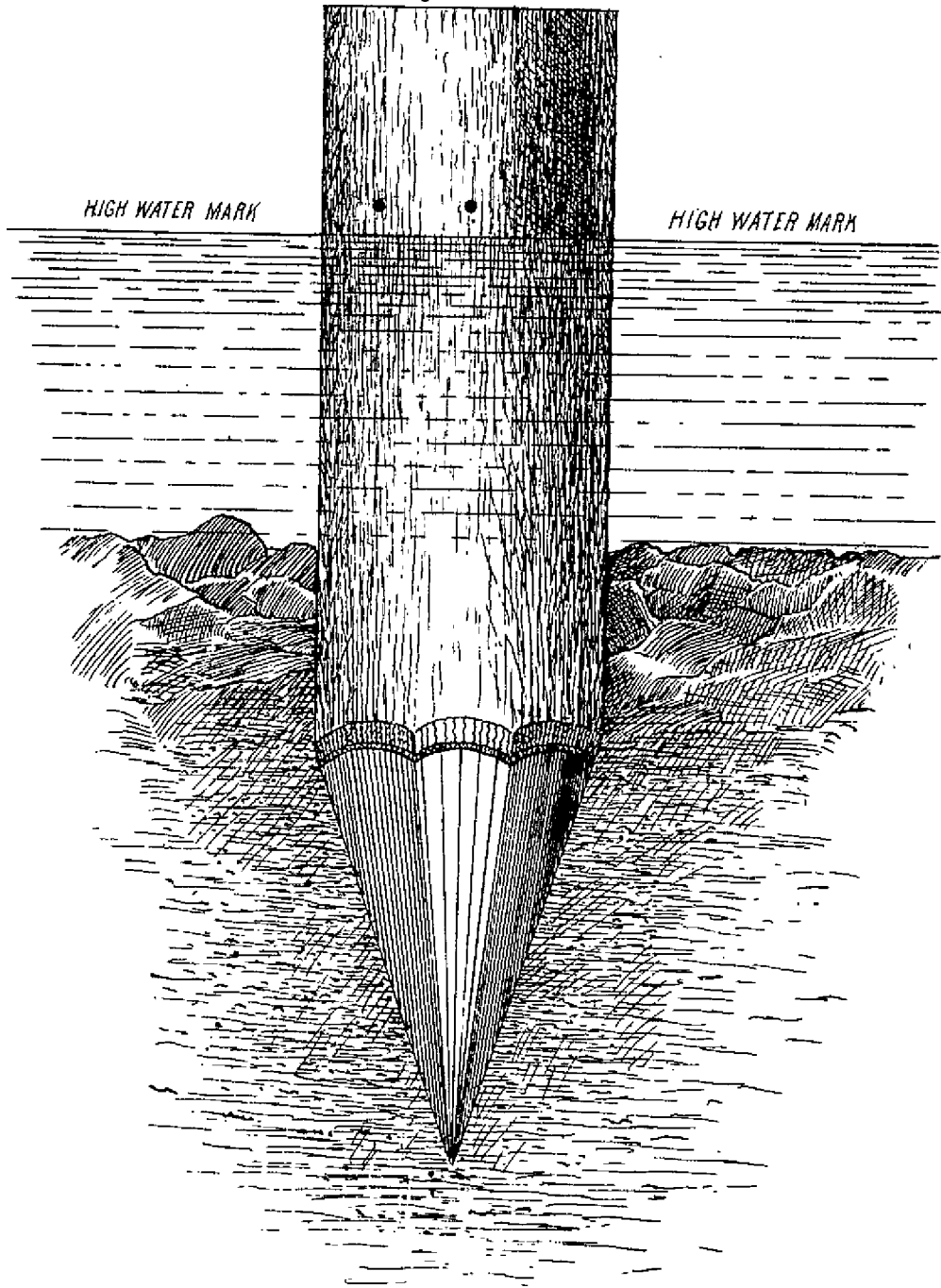
Sir,

In reference to your B.C. memo. of 20th instant, forwarding a petition for Letters of Registration for an invention entitled "A preparation for preserving piles or any other woodwork immersed or to be immersed in salt-water from the ravages of worms and other marine animals, and the mode of its application," we have the honor to inform you that, having examined the plan and specification accompanying the petition, we are of opinion that Letters of Registration for the invention may be issued in accordance with the prayer of the Petitioner.

We have, &c.,

JOHN WHITTON.
E. O. MORIARTY.

The Under Secretary of Justice.

Diagram A.*Diagram B.**Diagram C.*

*This is the Sheet of Drawings referred to in the annexed Letters
of Registration, granted to Samuel Henry Stockton, the sixth
day of August, A.D., 1884. Augustus Loftus.*



A.D. 1884, 6th August. No. 1476.

AN IMPROVED VENTILATING STOVE.

LETTERS OF REGISTRATION to Richard Oakley, for an Improved Ventilating Stove.

[Registered on the 6th day of August, 1884, in pursuance of the Act 16 Vic. No. 24.]

BY HIS EXCELLENCY THE RIGHT HONORABLE SIR AUGUSTUS WILLIAM FREDERICK SPENCER LOFTUS (commonly called LORD AUGUSTUS LOFTUS), Knight Grand Cross of the Most Honorable Order of the Bath, a Member of Her Majesty's Most Honorable Privy Council, Governor and Commander-in-Chief of the Colony of New South Wales and its Dependencies.

TO ALL TO WHOM THESE PRESENTS SHALL COME, greeting:

WHEREAS RICHARD OAKLEY, of 235, High Holborn, in the county of Middlesex, England, ventilating engineer, hath by his petition humbly represented to me that he is the author or designer of a certain invention or improvement in manufactures, that is to say, of an invention entitled "An Improved Ventilating Stove," which is more particularly described in the specification and the sheet of drawings which are hereunto annexed; and that he, the said Petitioner, hath deposited with the Honorable the Treasurer of the said Colony of New South Wales the sum of Twenty Pounds sterling, for defraying the expense of granting these Letters of Registration, as required by the Act of Council, sixteenth Victoria, number twenty-four; and hath humbly prayed that I would be pleased to grant Letters of Registration, whereby the exclusive enjoyment and advantage of the said invention or improvement might be secured to him for a period of fourteen years: And I, being willing to give encouragement to all inventions and improvements in the arts or manufactures which may be for the public good, and having received a report favourable to the prayer of the said Petition, from competent persons appointed by me to examine and consider the matters stated therein and to report thereon for my information, am pleased, with the advice of the Executive Council, and in exercise of the power and authority given to me by the said Act of Council, to grant, and do by these Letters of Registration grant unto the said Richard Oakley, his executors, administrators, and assigns, the exclusive enjoyment and advantage of the said invention or improvement, for and during the term of fourteen years from the date hereof; to have, hold, and exercise unto the said Richard Oakley, his executors, administrators, and assigns, the exclusive enjoyment and advantage thereof, for and during and unto the full end and term of fourteen years from the date of these presents next and immediately ensuing, and fully to be complete and ended: Provided always, that if the said Richard Oakley shall not, within three days after the granting of these Letters of Registration, register the same in the proper office in the Supreme Court, at Sydney, in the said Colony of New South Wales, then these Letters of Registration, and all advantages whatsoever hereby granted, shall cease and become void.

In witness whereof, I have hereunto set my sign manual, and have caused the present Letters of Registration to be sealed with the seal of the said Colony of New South Wales, at Government House, Sydney, in New South Wales, this sixth day of August, in the year of our Lord one thousand eight hundred and eighty-four.

[L.S.]

AUGUSTUS LOFTUS.

An Improved Ventilating Stove.

SPECIFICATION of RICHARD OAKLEY, of 235, High Holborn, in the county of Middlesex, England, ventilating engineer, for an invention entitled "An Improved Ventilating Stove."

It consists of two horizontal plates, either circular, square, or oblong, and of any size. These plates are perforated with an equal number of circular holes of any convenient diameter, and into these holes are fitted pipes of the same diameter of wrought iron or copper. The length of these pipes is not material. The whole of these pipes and the two heads or ends are cased in with a metal casing, and along the upper surface of the lower plate atmospheric or other gas burners are provided. These burners are not necessarily fixtures; they vary in size with the stove to which they are attached. The flames from these burners play around the outside of the tubes inside the casing. The tubes becoming heated, the cold air entering from below passes through them and comes out at the top, heated likewise. An opening is provided in the upper part of the casing to which is attached a flue pipe to carry off the fumes of the gas.

The Æolus multitubular ventilating stove is represented by the figures upon the drawing annexed. Figure 1 is a vertical section, and figure 2 is a plan. *a* and *b* are two horizontal plates, and *cc* are pipes fitted into holes in the plates, and forming passages connecting the space beneath the lower plate with the space above the upper plate. The tubes are enclosed in a casing *d* from which a pipe *e* passes out near the top to conduct away the fumes of the gas burnt within the casing to a chimney or elsewhere. At the lower part of the casing, in front, at *d'*, an opening is also left; it serves for the insertion of a gridiron gas-burner. The burner consists of parallel horizontal pipes entering between the rows of pipes *c* and perforated with orifices at which the gas is burnt. All the burner tubes are connected in front with one horizontal pipe at right angles to them, and into this gas mixed with air is passed by the arrangement usual in air-gas burners. *f* is a space provided beneath the plate *a* by preference. It communicates with the outer air. The gas burning amongst the pipes *c* heats them, and they then warm the air, which ascends by them from the space *f*. At the upper end of the pipes *c* the air enters the room or chamber to be ventilated and warmed.

Figure 3 indicates in elevation another form in which the ventilating stove may be arranged. The pipes by which the air is warmed in its passage are contained within the drum *h*. The gas-burner is, as before, immediately above the plate *a*, but it is not adapted to be drawn out, or the drum may be rectangular, in which case the gas-burner may be removable. The air to be warmed is led in by the trunk *i*, and a water spray may be arranged to fall within the trunk, propelling the air in a well-known manner, and forming what is known as a water-spray ventilator. The air may be propelled by a fan.

What I claim is—

The Æolus multitubular ventilating stove, substantially as described.

In witness whereof, I, the said Richard Oakley, have hereto set my hand and seal this seventeenth day of June, one thousand eight hundred and eighty-four.

RICHARD OAKLEY,
(By his Agent, BASIL G. WOOLLEY.)

Witness—

FRED. WALSH,
Manager, Edwd. Waters' Patent Office, Sydney.

This is the specification referred to in the annexed Letters of Registration granted to Richard Oakley, the sixth day of August, A.D. 1884.

AUGUSTUS LOFTUS.

REPORT.

Sir,

The application of Mr. Richard Oakley for Letters of Registration for an invention entitled "An Improved Ventilating Stove," having been referred to us, we have examined the plans and specification accompanying the same, and have now the honor to report that we see no objection to the issue of Letters of Registration as prayed for.

We have, &c.,
JAMES BARNET.
WILLIAM C. BENNETT.

The Under Secretary of Justice.

[Drawings—one sheet.]

No. 1477.

[Assignment of No. 1311. See Letters of Registration for 1883, page 407.]

No. 1478.

[Assignment of No. 1330. See Letters of Registration for 1883, page 471.]

No. 1479.

[Assignment of No. 1185. See Letters of Registration for 1883, page 35.]

No. 1480.

[Assignment of No. 1453. See Letters of Registration for 1884, page 281].

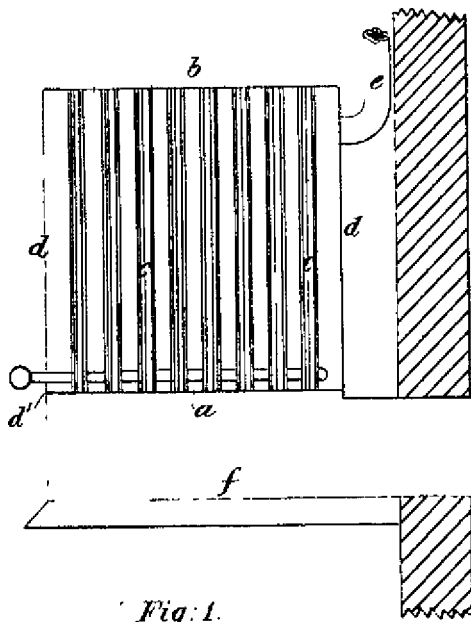


Fig. 1.

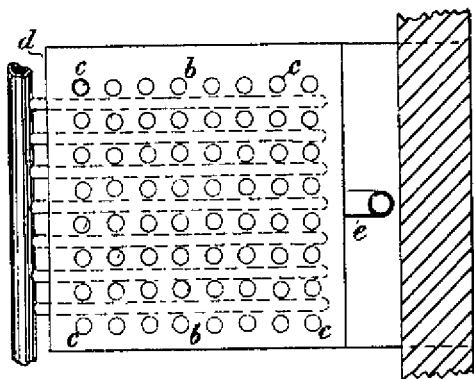


Fig. 2.

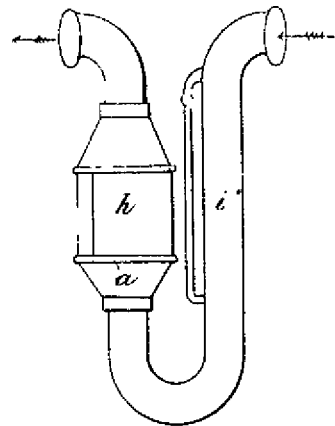


Fig. 3.

*This is the Sheet of Drawings referred to in the aforesaid
Letters of Registration, granted to Richard O'Brien,
the sixth day of August, A. D. 1884.*

Augustus Loftus.



A.D. 1884, 21st August. No. 1481.

IMPROVEMENTS IN AND FOR BORING IN THE EARTH.

LETTERS OF REGISTRATION to Norman Selfe, for Improvements in and for Boring in the Earth.

[Registered on the 22nd day of August, 1884, in pursuance of the Act 16 Vic. No. 24.]

BY HIS EXCELLENCY THE RIGHT HONORABLE SIR AUGUSTUS WILLIAM FREDERICK SPENCER LOFTUS (commonly called LORD AUGUSTUS LOFTUS), Knight Grand Cross of the Most Honorable Order of the Bath, a Member of Her Majesty's Most Honorable Privy Council, Governor and Commander-in-Chief of the Colony of New South Wales and its Dependencies.

TO ALL TO WHOM THESE PRESENTS SHALL COME, greeting :

WHEREAS NORMAN SELFE, of Sydney, in the Colony of New South Wales, consulting engineer, hath by his Petition humbly represented to me that he is the author or designer of a certain invention or improvement in manufactures, that is to say, of an invention entitled "Improvements in and for Boring in the Earth," which is more particularly described in the specification and the sheet of drawings which are hereunto annexed; and that he, the said Petitioner, hath deposited with the Honorable the Treasurer of the said Colony of New South Wales the sum of Twenty Pounds sterling, for defraying the expense of granting these Letters of Registration, as required by the Act of Council, sixteenth Victoria number twenty-four; and hath humbly prayed that I would be pleased to grant Letters of Registration, whereby the exclusive enjoyment and advantage of the said invention or improvement might be secured to him for a period of fourteen years: And I, being willing to give encouragement to all inventions and improvements in the arts or manufactures which may be for the public good, and having received a report favourable to the prayer of the said Petition, from competent persons appointed by me to examine and consider the matters stated therein and to report thereon for my information, am pleased, with the advice of the Executive Council, and in exercise of the power and authority given to me by the said Act of Council, to grant, and do by these Letters of Registration grant unto the said Norman Selfe, his executors, administrators, and assigns, the exclusive enjoyment and advantage of the said invention or improvement, for and during the term of fourteen years from the date hereof; to have, hold, and exercise unto the said Norman Selfe, his executors, administrators, and assigns, the exclusive enjoyment and advantage thereof, for and during and unto the full end and term of fourteen years from the date of these presents next and immediately ensuing, and fully to be complete and ended: Provided always that if the said Norman Selfe shall not, within three days after the granting of these Letters of Registration, register the same in the proper office in the Supreme Court, at Sydney, in the said Colony of New South Wales, then these Letters of Registration, and all advantages whatsoever hereby granted, shall cease and become void.

In witness whereof, I have hereunto set my sign manual, and have caused the present Letters of Registration to be sealed with the seal of the said Colony of New South Wales, at Government House, Sydney, in New South Wales, this twenty-first day of August, in the year of our Lord one thousand eight hundred and eighty-four.

[L.S.]

AUGUSTUS LOFTUS.

Improvements in and for Boring in the Earth.

SPECIFICATION of NORMAN SELFE, of Sydney, in the Colony of New South Wales, consulting engineer, for an invention entitled "Improvements in and for Boring in the Earth."

My improvements relate to an improved method and means of and for boring a hole or sinking a shaft in the earth or ground.

Referring to the drawings—Figure 2 shows, in sectional elevation, my improved method of boring a hole; figure 3 is an enlarged view of coupling G in figure 2, showing the valve R open; figure 4 is a plan of figure 3; figure 5 is an enlarged view of H, figure 2.

A is a bore-hole or shaft being drilled or bored; B is the rock or earth being perforated; C is an excavation made in surface soil to fix apparatus; D is a tube or casing firmly fixed over the centre of bore-hole, and made water-tight; E is the tubular boring-rod, made in sections with couplings and working water-tight through the cover of D; F is the cover and stuffing-box of D, made easily removable in halves or otherwise, so that the rods E and their couplings may be easily withdrawn from the bore; G G are couplings connecting the several sections of E; H is the drill or jumper on end of bore-rods E; J J are tools or cutters on boring-head to enlarge bore-hole made by H to bore-hole A; K is a perforated coupling on E, with a fixed collar, on which a loose sleeve that is made hollow over the perforations can freely revolve; L is a cross handle or wrench by which the rod E can be revolved when at work; M is a coupling on the top end of bore-rod E, fitted with a swivel, and connected to the rope from the spring-pole working beam or other appliance by which the rod E is operated; N is a pipe supplying water to D and A; O is a tank for water supply; P is an overflow pipe attached to the hollow sleeve on K; Q is a cock or valve, regulating the flow of water to bore; R R R are valves opening upwards on G G and H; S is the drill-point; T is a screwed neck connecting to drill-rod E; U is an opening in the body of drill; V is an opening bored through T into U.

In boring by this apparatus, the operation is the reverse of that in the diamond drills, where water is forced down the hollow bore-rods, for in this case the water is supplied to the bore itself from a level, as O, higher than the outlet on bore-rods P. When the rods and tools are lifted by the appliances provided, the water in D and A falls to take its place. When the tool is allowed to fall, the water should be driven back up the hole; but, as the metal of the rods is of greater specific gravity than the water, and on account of the friction of the water against the sides of bore-hole and outside of rods, or for other reasons, part of the water under the drill will pass up through U and V when the rods drop, and, lifting the valves R R, will be retained from flowing back when the rods are again lifted, the continuous working of the hollow rods and valves acting as a pump, and discharging a stream of water with all the debris of the cutting edges through P above the ground.

Although clack or hinge valves are shown, it is obvious that spherical or other forms of valve may be used, and that many forms of drills, augers, shells, or other boring tools may be used in a similar way with the same arrangements of rods and water connections.

What I claim is:—

First—The hollow boring-rods, having valves in them opening upwards, and boring by percussion with such hollow rods, substantially as herein described.

Second—The use of boring tools in connection with hollow rods and valves, and a provision for a water supply, substantially as described, for the purpose of removing the debris from a well or other bore-hole up through the rods themselves.

In witness whereof, I, the said Norman Selfe, have hereto set my hand and seal, this nineteenth day of June, one thousand eight hundred and eighty-four.

(Pro NORMAN SELFE),

HENRY SELFE.

Witness—

FRED. WALSH,

Manager, Edward Waters' Patent Office, Sydney.

This is the specification referred to in the annexed Letters of Registration granted to Norman Selfe, the twenty-first day of August, A.D. 1884.

AUGUSTUS LOFTUS.

REPORT.

Sir,

Sydney, 10 July, 1884

Having, in compliance with your B.C. minute of 25 June, examined the plans and specification accompanying the application of Mr. Norman Selfe for Letters of Registration for an invention entitled "Improvements in and for Boring in the Earth," we have to report that we see no reason why such letters should not be issued

We have, &c.,

JAMES BARNET

WILLIAM C. BENNETT.

The Under Secretary of Justice.

[Drawings—one sheet.]

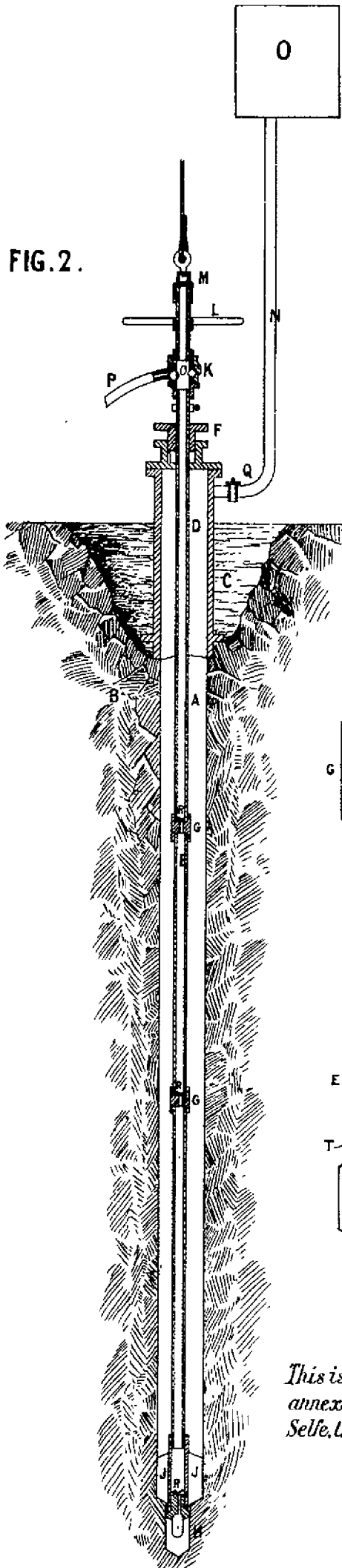


FIG. 2.

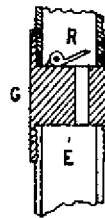


FIG. 3.



FIG. 4.

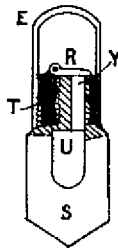


FIG. 5.

This is the Sheet of Drawings referred to in the annexed Letters of Registration, granted to Norman Selfe, the twenty-first day of August, A.D., 1884.

Augustus Loftus.



A.D. 1884, 21st August. No. 1482.

IMPROVEMENTS IN HYDRAULIC ELEVATORS.

LETTERS OF REGISTRATION to Norman Selfe, for Improvements in Hydraulic Elevators.

[Registered on the 22nd day of August, 1884, in pursuance of the Act 16 Vic. No. 24.]

BY HIS EXCELLENCY THE RIGHT HONORABLE SIR AUGUSTUS WILLIAM FREDERICK SPENCER LOFTUS (commonly called LORD AUGUSTUS LOFTUS), Knight Grand Cross of the Most Honorable Order of the Bath, a Member of Her Majesty's Most Honorable Privy Council, Governor and Commander-in-Chief of the Colony of New South Wales and its Dependencies.

TO ALL TO WHOM THESE PRESENTS SHALL COME, greeting:

WHEREAS NORMAN SELFE, of Sydney, in the Colony of New South Wales, consulting engineer, hath by his Petition humbly represented to me that he is the author or designer of a certain invention or improvement in manufactures, that is to say, of an invention entitled "Improvements in Hydraulic Elevators," which are more particularly described in the specification marked "A," and the two sheets of drawings marked "B" and "C" respectively, which are hereunto annexed; and that he, the said Petitioner, hath deposited with the Honorable the Treasurer of the said Colony of New South Wales the sum of Twenty Pounds sterling, for defraying the expense of granting these Letters of Registration, as required by the Act of Council, sixteenth Victoria number twenty-four; and hath humbly prayed that I would be pleased to grant Letters of Registration, whereby the exclusive enjoyment and advantage of the said invention or improvement might be secured to him for a period of fourteen years: And I, being willing to give encouragement to all inventions and improvements in the arts or manufactures which may be for the public good, and having received a report favourable to the prayer of the said Petition, from competent persons appointed by me to examine and consider the matters stated therein and to report thereon for my information, am pleased, with the advice of the Executive Council, and in exercise of the power and authority given to me by the said Act of Council, to grant, and do by these Letters of Registration grant unto the said Norman Selfe, his executors, administrators, and assigns, the exclusive enjoyment and advantage of the said invention or improvement, for and during the term of fourteen years from the date hereof; to have, hold, and exercise unto the said Norman Selfe, his executors, administrators, and assigns, the exclusive enjoyment and advantage thereof, for and during and unto the full end and term of fourteen years from the date of these presents next and immediately ensuing, and fully to be complete and ended: Provided always, that if the said Norman Selfe shall not, within three days after the granting of these Letters of Registration, register the same in the proper office in the Supreme Court, at Sydney, in the said Colony of New South Wales, then these Letters of Registration, and all advantages whatsoever hereby granted, shall cease and become void.

In witness whereof, I have hereunto set my sign manual, and have caused the present Letters of Registration to be sealed with the seal of the said Colony of New South Wales, at Government House, Sydney, in New South Wales, this twenty-first day of August, in the year of our Lord one thousand eight hundred and eighty-four.

[L.S.]

AUGUSTUS LOFTUS.

Improvements in Hydraulic Elevators.

"A."

SPECIFICATION of NORMAN SELFE, of Sydney, in the Colony of New South Wales, consulting engineer, for an invention entitled "Improvements in Hydraulic Elevators."

THESE improvements relate: First—To the construction of a hydraulic balance to equalize the varying power of a vertical hydraulic ram when worked by a constant pressure of water, and enable the usual balance weights and ropes or chains to be dispensed with; and secondly—to the regulation of the flow of water to and from the cylinder of the elevator by a valve in which the passages are opened and closed without shock.

Fig. 1, sheet "A," shows a direct acting elevator with my improved hydraulic balance attached. A is the well-hole or shaft of the elevator. B is the car or cage. C is the ram of hydraulic lift, with stroke equal to full lift. D is the cylinder or casing in which ram C works. E is the well, shaft, or bore-hole made in the ground for D. F is an elevated tank to supply water under pressure to the lift. G is a low-level tank for the water used by the elevator. H is a pump to raise water from G to F. J is the suction-pipe of pump H from tank G. K is the delivery-pipe of pump H to tank F. L is the supply-pipe from tank F to the hydraulic valve of lift. M is the hydraulic valve regulating the working of the elevator. N is a pipe from outlet of M to cylinder of balance ram. O is a pipe from waste branch of M to tank G. P is a hydraulic ram of a capacity or displacement equal to ram C. Q is the cylinder of ram P, and externally a ram with double the area or displacement of rams P or C. R is the inverted cylinders of ram Q. S is a view of two, three, or more columns, connecting the sole-plate of ram P with the top of cylinder R. T is a pipe connecting cylinder Q of ram P with the cylinder D of ram C. U is a smaller pipe connecting pipe T with the supply tank F through pipe L. V is a cock or valve on pipe U kept closed by a lever and balance weight, except when opened by a projection on the car B at the bottom of its stroke. W is another cock or valve on pipe U kept open by a lever and balance weight, except when closed by a projection on the cylinder ram Q at the top of its stroke. X is a line or cable passing through car to operate valve M. Y Y Y Y are guide-sheaves for cable X. Z is the controlling pulley of valve M worked by the ends of the cable X. a is a lever for opening valve V. b is a counter-weight to keep valve V closed. c is a lever for opening and shutting valve W. d is a counter-weight to keep W open. e is a projection on flange of Q to close W when it rises. f is a driving pulley to pump H. g, h, and j are the packing boxes to Q, R, and E respectively. k is a projection on B to strike a and close V when B is down.

When the elevator is to be worked, motive power is applied to the pump, and water is raised to the elevated tank and descends the pipes L and U as far as the valves M and V or W. If the car is at the bottom of the stroke, valve V will be open; and if the cylinders D and Q are empty, then Q will be down, and the valve W will be open, and the water will flow from the supply tank F, and fill cylinder D and then cylinder Q, until Q rises to the top of its stroke and shuts valve W by the projection, the air being let out by provisions as understood. Cylinder Q may be filled up either before or after the balance-weights are put on. The counterpoise of balance-weights and the water in R is made so much less than the weight of car and ram B and C that the excess weight of the latter will overcome the friction of packing, and descend when valve M opens cylinder R to waste pipe O. The operator in the car desiring to rise, pulls down the cable X, and by means of the valve M opens a communication between the tank F and cylinder R. The pressure of water on Q forces it down, and at the same time forces the water out of P; but as P is only one-half the area of Q, the pressure in pipe T and cylinder D is approximately double of that in R, and the ram C may be approximately one-half the area which would be necessary if it were worked direct from F. Or inversely, the tank F need only be half the height for the same ram of elevator which would be necessary if worked direct. As the ram C rises out of the water in D its effective weight increases as the weight of water displaced is reduced, and at the same time the displacement D and Q is reduced by the same amount; but as Q descends the displacements or contents in R is increased by the equivalent C and P put together; or, in other words, the pressure on the top end of ram Q increases directly as its depth below the water level of F increases, and thus an approximately equal lifting power is maintained in car B at all parts of the stroke. When the car has ascended, and it is desired to descend, the cable is lifted up, communication is made between R and pipe O to tank G, and the surplus weight of car and ram forces the water through T to P, raises Q, and discharges the contents of R into G to be pumped up and used again. If any leakage should take place through the glands of cylinders D and Q, and Q should fall while C is still down, there would not be water in P Q to make a full lift; but the action of valves V and W prevent such an occurrence taking place, as they maintain automatically the necessary supply to D and P.

Although this hydraulic balance is shown connected to a high level tank, it is obvious that the pipe L might be connected to an accumulator with similar results; and although I have described the relative proportions of rams P and Q as two to one, they may be varied to suit circumstances, as in the foregoing description no mention has been made as to the friction in glands and packings which modify the effective results obtained from given areas of ram and pressures.

Figs. 1, 2, and 3 on sheet "B" represent different forms of hydraulic elevator valves, constructed with my improvements attached. The same letters where they are used apply to all the figures on said sheet "B." A is a wheel to operate the valve by hand-cable from the car. B is the spindle or axle of A. C is the pressure or supply branch to the valve. D is the branch connecting to elevator. E is the branch to waste or return water. F is the spindle of valve. G 1 to 6 are cupped leathers, and G 7 and 8 flat leathers making watertight joints of valves. H 1 to 4 are conoidal or egg-shaped bodies on the valves to close the orifices very gradually as the valves are moved, and prevent a sudden stoppage of the water-flow, with consequent shock or concussion, when the valves are operated for raising or lowering the elevators. K is a perforated chamber to valve, fig. 2, secured in the shell of valve, and made easily removable by a centre flange. L 1 and 2 are cams to lift the disc valves G 7 and 8. M is a valve opening upwards from the branch connected with the elevator into the supply branch. It is thus kept down by the full pressure of the water, and only opens if the waste branch is closed suddenly to arrest a descending load in the elevator, when it prevents concussion or shock in the ram and car. It is applicable to any forms of elevator valves.

Many

Improvements in Hydraulic Elevators.

Many parts and arrangements shown in the drawings are well known ; but what I claim as novel, and seek protection for by Letters of Registration, is as follows :—

First—The construction of an hydraulic balance to the varying load of a direct lift by means of two inverted hydraulic presses in which the cylinder of the smaller one forms the ram of the larger one, substantially as described.

Second—The application of the same or similar arrangement to enable a low-pressure water supply to work a higher pressure in elevator cylinder.

Third—The construction of the valves for hydraulic elevators with conoidal bodies for the purpose of closing the water passages without shock.

Fourth—The construction of a balance piston-valve with a perforated body, kept in place by a centre flange, substantially as shown.

Fifth—The construction of the regulating valve of an hydraulic elevator with a shock or concussion valve opening from elevator branch into the pressure branch, substantially as shown.

In witness whereof, I, the said Norman Selfe, have hereto set my hand and seal.

Witness—

FRED. WALSH,

Mgr., Edwd. Waters' Patent Office, Sydney.

(Pro NORMAN SELFE),

HENRY SELFE.

This is the specification marked "A," referred to in the annexed Letters of Registration granted to Norman Selfe, the twenty-first day of August, A.D. 1884.

AUGUSTUS LOFTUS.

REPORTS.

Sir,

Sydney, 13 March, 1884.

In accordance with your minute of 20th February, forwarding application from Mr. Norman Selfe for Letters of Registration for an invention entitled "Improvements in Hydraulic Machinery," we have to report that the improvements have not been patented in the Colony, and to add that as the application covers two separate and distinct claims, one for improvement in the hydraulic machinery of lifts, and the other for improvements in boring machinery, we are not in a position to state whether an application should comprise two inventions of so different a character; otherwise, we see no objection to the issue of such letters.

We have, &c.,

JAMES BARNET.

WILLIAM C. BENNETT.

The Under Secretary of Justice.

Sir,

Sydney, 10 July, 1884.

In accordance with your B.C. minute of the 24th June, we have examined the plans and specification attached to the application of Mr. Norman Selfe for Letters of Registration for an invention entitled "Improvements in Hydraulic Elevators," and have to report that we now see no reason why such letters should not be issued.

We have, &c.,

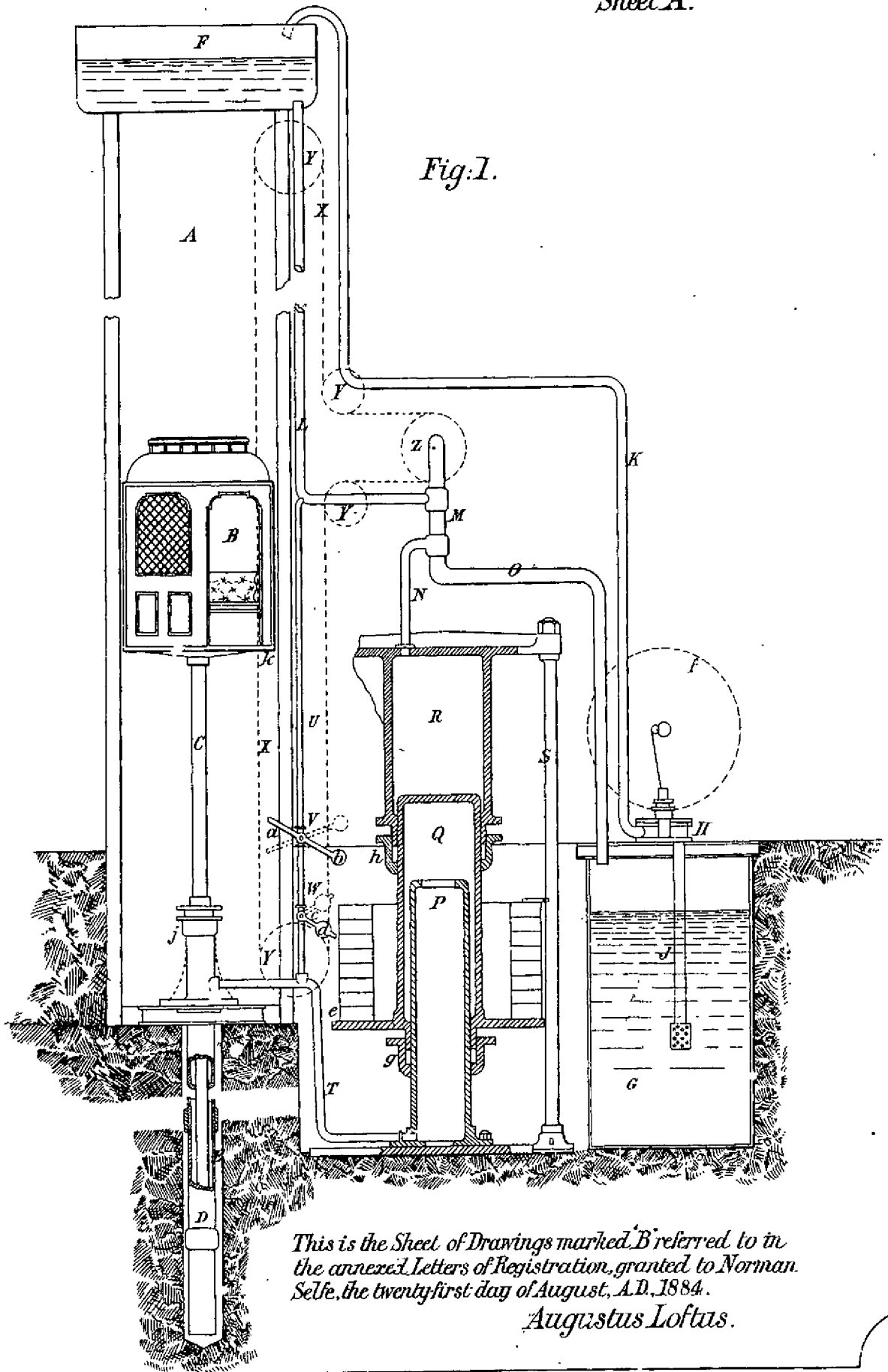
JAMES BARNET.

WILLIAM C. BENNETT.

The Under Secretary of Justice.

SELFE'S IMPROVEMENTS IN HYDRAULIC MACHINERY

Sheet A.



This is the Sheet of Drawings marked 'B' referred to in the annexed Letters of Registration, granted to Norman Selfe, the twentyfirst day of August, A.D. 1884.

Augustus Loftus.

(Sig: 24^F-)

SELFE'S IMPROVEMENTS IN HYDRAULIC MACHINERY.

Sheet B.

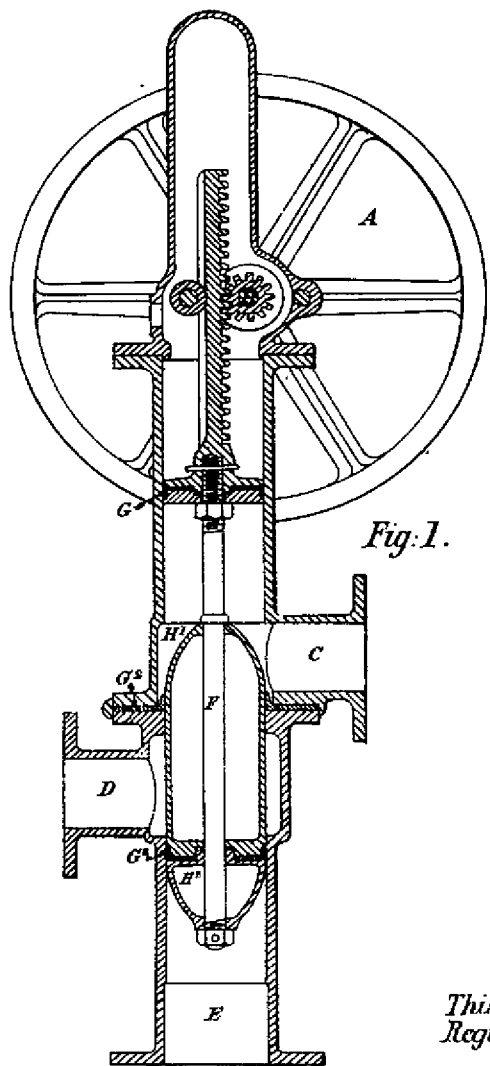


Fig. 1.

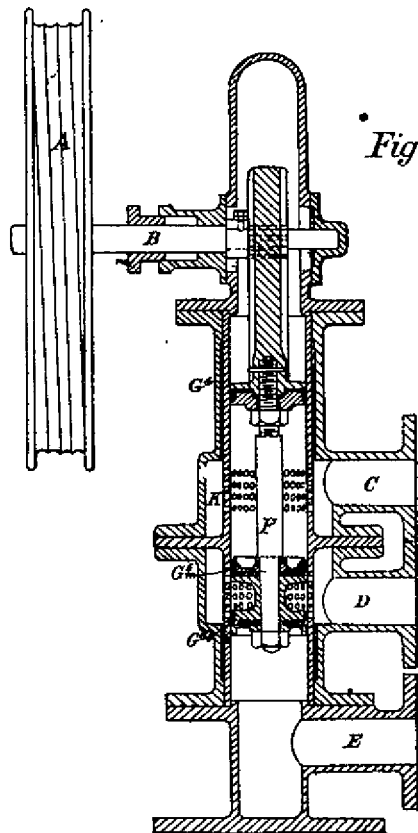


Fig. 2.

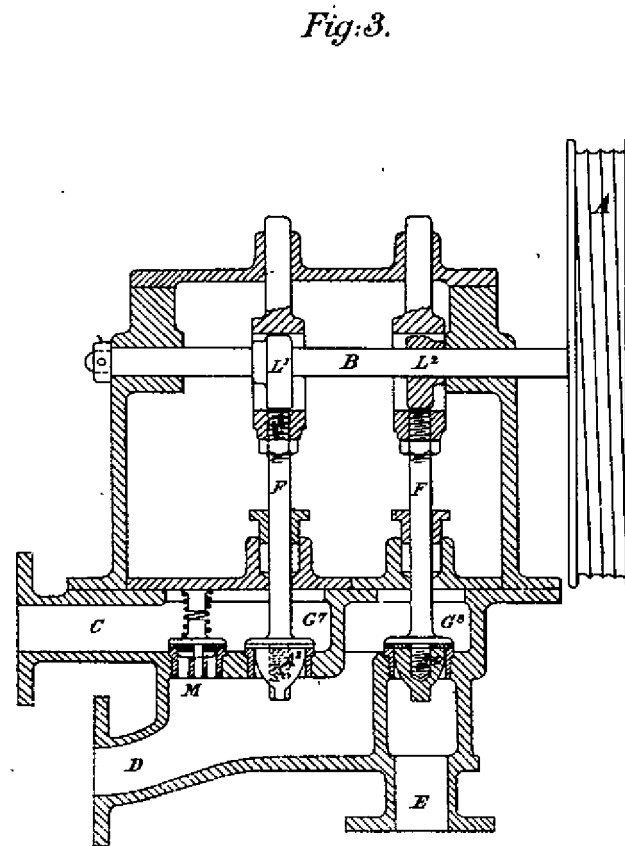


Fig. 3.

This is the Sheet of Drawings marked 'C' referred to in the annexed Letters of Registration, granted to Norman Selfe, the twenty-first day of August A.D., 1884.

Augustus Loftus.

Norman Selfe



A.D. 1884, 21st August. No. 1483.

IMPROVEMENTS IN EARTH EXCAVATORS.

LETTERS OF REGISTRATION to Samuel Rupert Wilson, for Improvements in Earth Excavators.

[Registered on the 22nd day of August, 1884, in pursuance of the Act 16 Vic. No. 24.]

BY HIS EXCELLENCY THE RIGHT HONORABLE SIR AUGUSTUS WILLIAM FREDERICK SPENCER LOFTUS (commonly called LORD AUGUSTUS LOFTUS), Knight Grand Cross of the Most Honorable Order of the Bath, a Member of Her Majesty's Most Honorable Privy Council, Governor and Commander-in-Chief of the Colony of New South Wales and its Dependencies.

TO ALL TO WHOM THESE PRESENTS SHALL COME, greeting :

WHEREAS SAMUEL RUPERT WILSON, of Norwood, engineer, hath by his Petition humbly represented to me that he is the author or designer of a certain invention or improvement in manufactures, that is to say, of an invention entitled "Improvements in Earth Excavators," which is more particularly described in the specification and the sheet of drawings which are hereunto annexed; and that he, the said Petitioner, hath deposited with the Honorable the Treasurer of the said Colony of New South Wales the sum of Twenty Pounds sterling for defraying the expenses of granting these Letters of Registration, as required by the Act of Council, sixteenth Victoria, number twenty-four; and hath humbly prayed that I would be pleased to grant Letters of Registration whereby the exclusive enjoyment and advantage of the said invention or improvement might be secured to him for a period of fourteen years: And I, being willing to give encouragement to all inventions and improvements in the arts or manufactures which may be for the public good, and having received a report favourable to the prayer of the said Petition from competent persons appointed by me to examine and consider the matters stated therein and to report thereon for my information, am pleased, with the advice of the Executive Council, and in exercise of the power and authority given to me by the said Act of Council, to grant, and do by these Letters of Registration grant unto the said Samuel Rupert Wilson, his executors, administrators, and assigns, the exclusive enjoyment and advantage of the said invention or improvement, for and during the term of fourteen years from the date hereof; to have, hold, and exercise unto the said Samuel Rupert Wilson, his executors, administrators, and assigns, the exclusive enjoyment and advantage thereof for and during and unto the full end and term of fourteen years from the date of these presents next and immediately ensuing, and fully to be complete and ended: Provided always, that if the said Samuel Rupert Wilson shall not, within three days after the granting of these Letters of Registration, register the same in the proper office in the Supreme Court, at Sydney, in the said Colony of New South Wales, then these Letters of Registration and all advantages whatsoever hereby granted, shall cease and become void.

In witness whereof, I have hereunto set my sign manual, and have caused the present Letters of Registration to be sealed with the seal of the said Colony of New South Wales, at Government House, Sydney, in New South Wales, this twenty-first day of August, in the year of our Lord one thousand eight hundred and eighty-four.

[L.S.]

AUGUSTUS LOFTUS.

Improvements in Earth Excavators.

TO ALL TO WHOM THESE PRESENTS SHALL COME: I, SAMUEL RUPERT WILSON, of Norwood, engineer, send greeting:

WHEREAS I, the said Samuel Rupert Wilson, am the inventor of certain improvements for "Improvements in Earth Excavators": Now know ye that I, the said Samuel Rupert Wilson, do hereby declare the nature of my said improvements, and in what manner the same are to be performed, to be particularly described and ascertained in and by the following statement, that is to say—the object of my invention is to facilitate and cheapen the cost of digging and removing earth from wells, tanks, dams, foundations, cellars, and other excavations, and the manner in which my machine is constructed, and the mode in which it is applied and worked, are set forth in the following specifications and the accompanying drawings:—Upon a carriage mounted upon a set of ordinary waggon wheels and axles, a side view of which is shown in fig. 1, and an end view in fig. 2, which are connected together with light wooden or iron girders, I place my machine and engine, the number of wheels and distance of axles apart being arranged according to the size and number of the excavators to be placed upon it. Upon this carriage a timber or iron framework AAAA is constructed, to which the excavating and elevating machinery is attached. This frame, when constructed of wood, may be of 6 x 4 Jarrah, well-mortised and firmly bolted together with $\frac{3}{4}$ -in. bolts at each tennon, with a nut at each end for screwing the frame together. The ladder is of 4 x 4 Jarrah, with distance pieces mortised and properly fitted and bolted together firmly, as shown, and made to slide in a frame constructed of 4 x 4 Jarrah, bolted and strutted together as directed. When constructed of iron, I use angle iron, or tubing, of dimensions and strength proportionate to the work required to be performed. I will first of all explain the excavator. The centre or main shaft B is made of 3-inch square steel or iron, or it may be a screwed shaft, with bearings and collars, and is chased 3 inches at the bottom end to take a screw point which acts as a jamb-nut to keep the knife in place. The knife fits square on to the foot of the shaft. To the lower end of this shaft I attach knives or cutters C. These knives or cutters are made of steel forged solid on the cross head with three arms placed slightly on edge, or the cutter may be of steel bolted into a wrought-iron arm underneath, with sunk heads on the bolts. The arms are supported by stays from the shaft just to clear the elevators, and on the outer edge they have a rim of wrought-iron at least 8 inches deep. The shaft has an auger head D which penetrates the earth and keeps the cutter or knife steady. Power is applied to the vertical shaft by a crown wheel E and pinion F, the crown wheel working in a bush in the centre to take the thrust and thereby keep the strain off the keys. On the top of main shaft are fitted a pair of bevel wheels GG for working the tumbler shaft, which is 2 inches diameter with hexagon tumblers, which in revolving turn an endless chain, with buckets attached. The shaft slides through the crown wheel as sinking goes on, carrying the elevators with it.

The elevator frames are constructed of wood or iron, and connected with the centre shaft by two cast-iron brackets, in which the shaft revolves. These frames and the shaft all slide down as the excavation proceeds through guides EEEE, which are built up to keep them in place. The elevators HH, which are cups or tumblers made of iron, tin, wood, or other suitable material, are fastened on to the chain or linked belt, made of $1\frac{1}{2}$ -inch x $\frac{3}{4}$ -inch iron with male and female joints and steel pins, and are operated by the pair of bevel wheels GG. In this framework two sets of elevators work—one on each side of the shaft, and a sufficient number of buckets are fixed to them to raise twice the quantity of earth cut by the revolving knives—the buckets being connected together either by forked or double links long enough to suit the revolving tumblers. The buckets are made of No. 14 gauge iron, and of sufficient capacity to lift the earth as it is loosened by the cutter.

The engine by which motive power is supplied is a horizontal engine with a vertical boiler. These stand upon a cast-iron frame I, which is placed on the front part of the carriage, the excavating and elevating machinery being fixed as near to the back axle as is convenient for the proper working of the knives or cutters.

I will now proceed to describe the method of working my invention. I may premise that the total weight of the whole apparatus as represented in the drawing, which is designed to cut and remove one cube yard of earth per minute, including wheels, carriage, engine, excavators, elevators, and working gear, is about $5\frac{1}{2}$ tons. The whole apparatus is drawn to the locality where the excavation is to be made, and steam having been got up, the machine is brought into operation, and as the revolving cutter excavates the earth the elevators lift the loose soil and carry it to the top of the frame, where it is emptied into a shoot to be deposited where required. The whole framework descends as the earth is cut away, the depth to which the machine represented in the drawing can descend being 12 feet. The range of action of the knives, however, can be increased or reduced according to circumstances. The facility with which this apparatus can be applied to the excavation and removal of earth from shallow wells, dams, foundations, cellars, or other large excavations, is apparent. Its portability and economy of working are also advantages, which are evident. A 6-horse-power engine is quite sufficient to excavate and elevate at least one cube yard of soil per minute, and as all the parts are self-acting the machine only requires two men—the one to work the machine, and the other to drive the engine.

CLAIMS.

Having fully explained my invention and the manner in which it is worked, I wish it to be understood that what I claim as my invention, and wish to be protected, is:—

First—A set of knives or cutters C attached to a shaft B, and made to revolve for the purposes of excavating earth, such cutters descending into the ground as the work proceeds, substantially as described in these specifications and shown in the drawings deposited herewith.

Second—In combination with such revolving excavators, one or more sets of elevators H, fixed substantially, as shown, for the purpose of removing the earth or spoil as it is excavated by the cutters.

Third—

Improvements in Earth Excavators.

Third—The combination of the various parts of a machine for excavating earth and removing the same from wells, dams, tanks, foundations, cellars, and other excavations, substantially as described herein and shown in the drawings deposited herewith.

In witness whereof, I have hereunto set my hand and seal, this twenty-fifth day of June, in the year of our Lord one thousand eight hundred and eighty-four.

Witness—

JNO. FAIRFAX CONIGRAVE, Licensed Patent Agent, Adelaide.

S. R. WILSON.

This is the specification referred to in the annexed Letters of Registration granted to Samuel Rupert Wilson the 21st day of August, A.D. 1884.

AUGUSTUS LOFTUS.

REPORT.

Sir,

Sydney, 10 July, 1884.

Having, in accordance with your instructions of 30th June, examined the plan and specification accompanying the application of Mr. Samuel Rupert Wilson, for Letters of Registration for an invention entitled "Improvements in Earth Excavators," we have to report that we can see no reason why such letters should not be issued.

We have, &c.,
JAMES BARNET.
WILLIAM C. BENNETT.

The Under Secretary of Justice.

[Drawings--one sheet.]

WILSON'S PATENT EARTH EXCAVATOR.

Scale 3/4 inch.

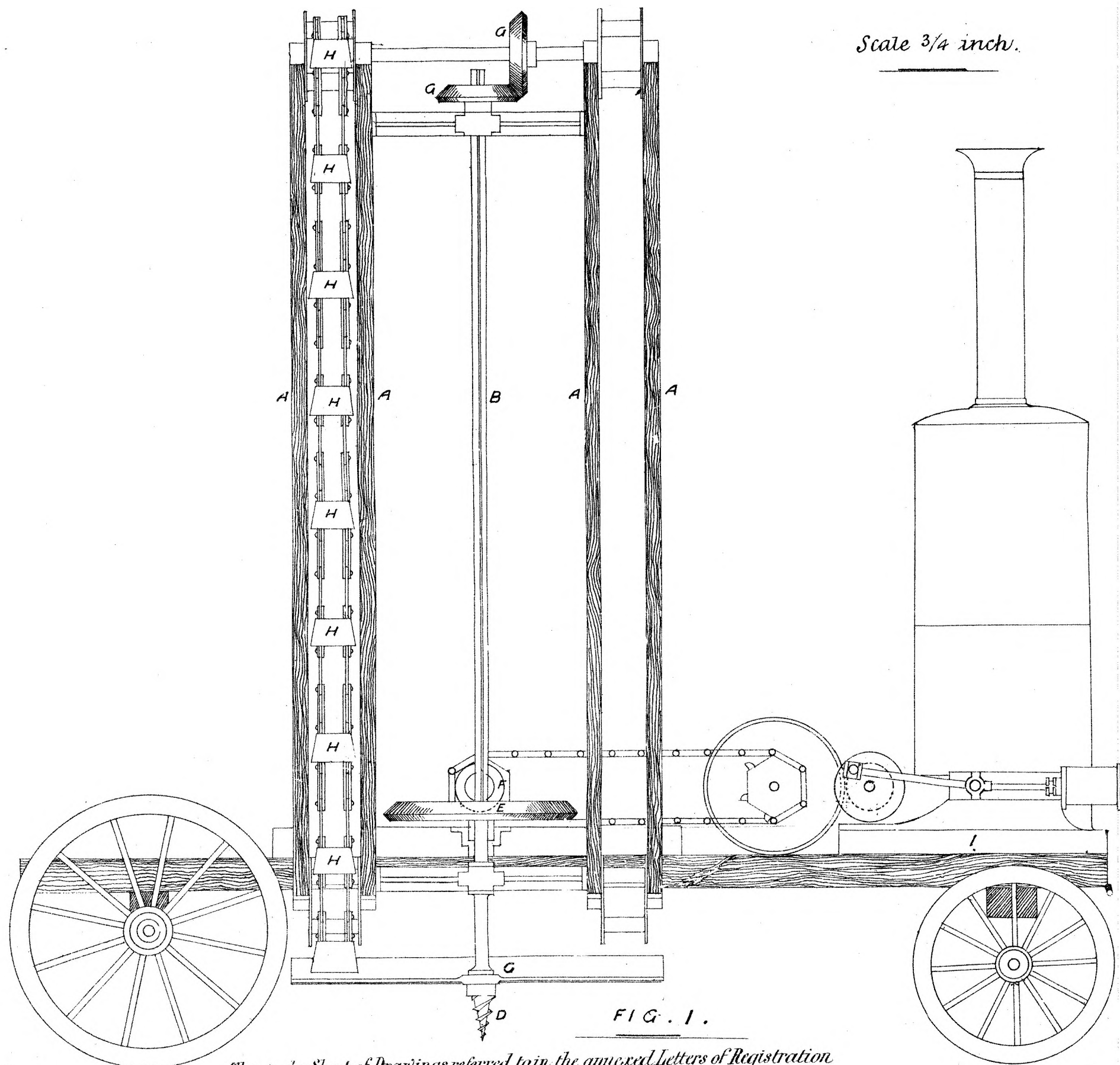


FIG. 1.

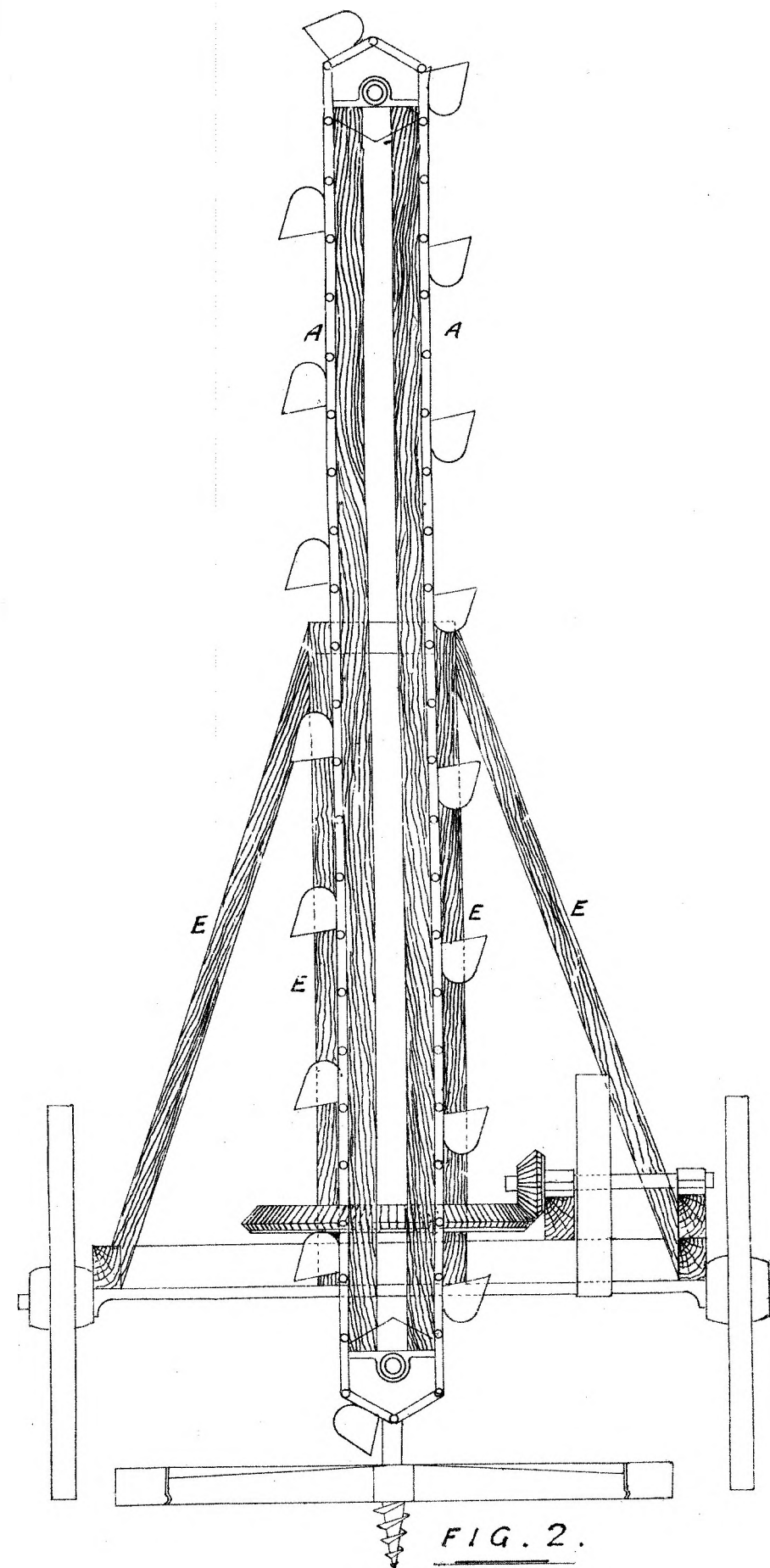


FIG. 2.

This is the Sheet of Drawings referred to in the annexed Letters of Registration granted to Samuel Rupert Wilson, the twentyfirst day of August, A. D., 1884.
Augustus Loftus.

(Sig: 245-)



A.D. 1884, 21st August. No. 1484.

**IMPROVEMENTS IN AND CONNECTED WITH THE ARRANGEMENT OF SHEEP
AND CATTLE TROUGHS IN RELATION TO DAMS OR TANKS.**

LETTERS OF REGISTRATION to Thomas Forrest Cumming, for Improvements in and connected with the arrangement of Sheep and Cattle Troughs in relation to Tanks and Dams.

[Registered on the 22nd day of August, 1884, in pursuance of the Act 16 Vic. No. 24.]

BY HIS EXCELLENCY THE RIGHT HONORABLE SIR AUGUSTUS WILLIAM FREDERICK SPENCER LOFTUS (commonly called LORD AUGUSTUS LOFTUS), Knight Grand Cross of the Most Honorable Order of the Bath, a Member of Her Majesty's Most Honorable Privy Council, Governor and Commander-in-Chief of the Colony of New South Wales and its Dependencies.

TO ALL TO WHOM THESE PRESENTS SHALL COME, greeting :

WHEREAS THOMAS FORREST CUMMING, a Member of the Legislative Council of the Colony of Victoria, hath by his Petition humbly represented to me that he is the author or designer of a certain invention or improvement in manufactures, that is to say, of an invention entitled "Improvements in and connected with the arrangement of Sheep and Cattle Troughs in relation to Dams or Tanks," which is more particularly described in the amended specification and the sheet of drawings which are hereunto annexed ; and that he, the said Petitioner, hath deposited with the Honorable the Treasurer of the said Colony of New South Wales the sum of Twenty Pounds sterling, for defraying the expense of granting these Letters of Registration, as required by the Act of Council, sixteenth Victoria, number twenty-four ; and hath humbly prayed that I would be pleased to grant Letters of Registration, whereby the exclusive enjoyment and advantage of the said invention or improvement might be secured to him for a period of fourteen years : And I, being willing to give encouragement to all inventions and improvements in the arts or manufactures which may be for the public good, and having received a report favourable to the prayer of the said Petition, from competent persons appointed by me to examine and consider the matters stated therein and to report thereon for my information, am pleased, with the advice of the Executive Council, and in exercise of the power and authority given to me by the said Act of Council, to grant, and do by these Letters of Registration grant unto the said Thomas Forrest Cumming, his executors, administrators, and assigns, the exclusive enjoyment and advantage of the said invention or improvement, for and during the term of fourteen years from the date hereof ; to have, hold, and exercise unto the said Thomas Forrest Cumming, his executors, administrators, and assigns, the exclusive enjoyment and advantage thereof, for and during and unto the full end and term of fourteen years from the date of these presents next and immediately ensuing, and fully to be complete and ended : Provided always, that if the said Thomas Forrest Cumming shall not, within three days after the granting of these Letters of Registration, register the same in the proper office in the Supreme Court, at Sydney, in the said Colony of New South Wales, then these Letters of Registration, and all advantages whatsoever hereby granted, shall cease and become void.

In witness whereof, I have hereunto set my sign manual, and have caused the present Letters of Registration to be sealed with the seal of the said Colony of New South Wales, at Government House, Sydney, in New South Wales, this twenty-first day of August, in the year of our Lord one thousand eight hundred and eighty-four.

[L.s.]

AUGUSTUS LOFTUS.

Improvements in and connected with the arrangement of Sheep and Cattle Troughs.

SPECIFICATION of THOMAS FORREST CUMMING, a Member of the Legislative Council of the Colony of Victoria, for an invention entitled "Improvements in and connected with the arrangement of Sheep and Cattle Troughs in relation to Dams or Tanks."

My invention has been designed for the purpose of providing a cheap and easy method of ensuring a constant supply of water to sheep and cattle troughs, so long as there is any water in the dam or tank. I accomplish this without the aid of any power, manual, mechanical, or otherwise, thus: In close proximity to the tank or dam I make an excavation approximating to a trough-like shape, that is to say, with a narrow bottom and long sloping sides, the bottom of which is below the level of the bottom of the dam or tank. Along the bottom of this trough-like excavation I erect the sheep and cattle troughs, which I supply with water by means of connecting pipes from the tank or dam, and control the supply by means of a ball-cock, as is well understood. That end of the supply pipe which is in the tank I preserve near the surface by means of a float. And to provide for the contingency of a heavy fall of rain in the trough-like excavation I make a drain well therefor and supply it with a pump, which must be worked in the ordinary way whenever so required. This pump should be so placed as to conduct the pumped water into the tank or dam.

Referring to my drawings, figure 1 is an isometrical perspective view illustrative of my invention; figure 2 is a longitudinal vertical section through centre line of same; figure 3 is a vertical section through the divisional embankment, showing the arrangement of pipes, pump, &c., to a larger scale; figure 4 is a cross-section of the feeding-trough tank; figures 5 and 6 are details of the stand pipe, drawn quarter size; A is the tank or dam surrounded by the embankment B and fence C; D is the pipe through which the water flows into the trough E, placed at a lower level than the bottom of the tank A in the excavation F, whose sides are cut on an easy slope; D¹ is a flexible hose connected to end of pipe D, and D² float for holding end of said hose near to the top of the water; H is the drain well, and H¹ pump for emptying it. In figure 4, E is the trough with delivery-pipe D and cock D³, the supply through which is regulated by means of the ball D⁴ attached to it and floating on the surface of the water in said trough E.

Having thus described the nature of my invention, and the manner of performing same, I would have it understood that I do not claim broadly the supplying of water-trough with water by placing them on a lower level than their supplying reservoir, but what I do claim as my improvements in and connected with the arrangement of sheep and cattle troughs in relation to dams or tanks, is—

First—Placing such trough in a trough-like excavation made in close proximity to and to a lower level than their supplying reservoir, and connecting them therewith by a suitable pipe, the supply through which is controlled by a ball-cock or other equivalent device, substantially as herein described and explained.

THOS. F. CUMMING.

This is the amended specification referred to in the annexed Letters of Registration granted to Thomas Forrest Cumming, the twenty-first day of August, A.D. 1884.

AUGUSTUS LOFTUS.

REPORT.

Sir,

Sydney, 21 July, 1884.

In returning to you the documents transmitted for our report under your B.C. communication dated the 15th instant, and which have reference to the Petition of Mr. Thomas Forrest Cumming, praying for a grant of Letters of Registration for his invention entitled "Improvements in and connected with Sheep and Cattle Troughs in relation to Dams and Tanks," we do ourselves the honor to state that we consider Letters of Registration may be granted for the improved construction of watering troughs in connection with dams or tanks as described.

With regard, however, to claim No. 2 for the construction of a drainage well to the trough excavation, we are of opinion that it does not exhibit such novelty of contrivance as would warrant Letters of Registration being granted therefor.

We have, &c.,

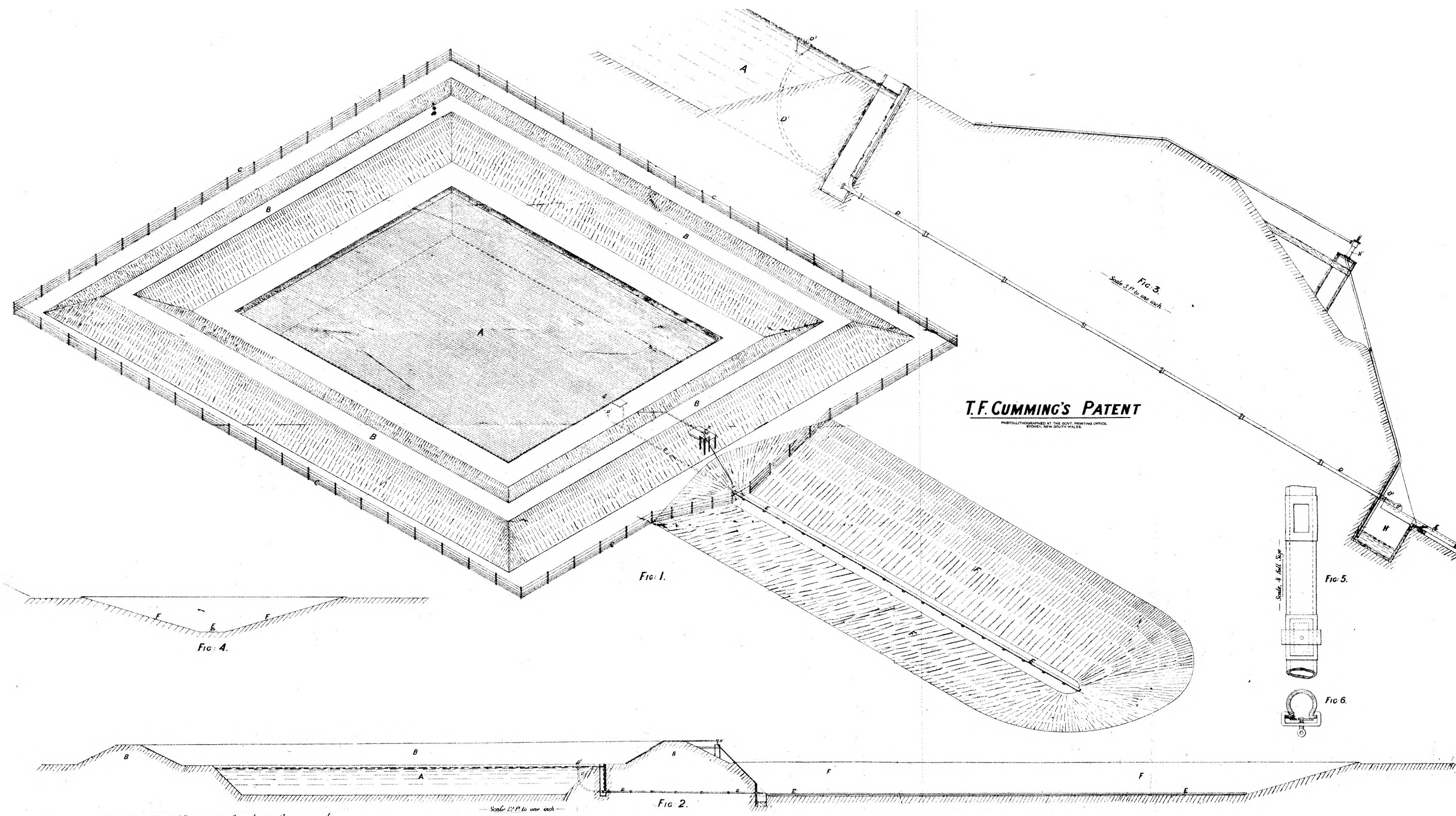
EDMUND FOSBERY.
CHARLES COWPER.

The Under Secretary of Justice.

MEMO.—We recommend that Letters of Registration be granted in terms with the amended claim and specification.

28th July, 1884.

EDMUND FOSBERY.
CHARLES COWPER.



T.F. CUMMING'S PATENT
PHOTOLITHOGRAPHED AT THE GOVT. PRINTING OFFICE,
 SYDNEY, NEW SOUTH WALES.

(Sig. 245-) This is the Sheet of Drawings referred to in the annexed
 Letters of Registration, granted to Thomas Forrest Cumming,
 the twenty-first day of August, A.D. 1884.
 Augustus Loftus.



A.D. 1884, 21st August. No. 1485.

IMPROVED HEDGE-TRIMMER, LAND-CLEARER, AND HARVESTING MACHINE.

LETTERS OF REGISTRATION to William M'Laughlin, for Improved Hedge-trimmer, Land-clearer, and Harvesting Machine.

[Registered on the 22nd day of August, 1884, in pursuance of the Act 16 Vic. No. 24.]

BY HIS EXCELLENCY THE RIGHT HONORABLE SIR AUGUSTUS WILLIAM FREDERICK SPENCER LOFTUS, (commonly called LORD AUGUSTUS LOFTUS), Knight Grand Cross of the Most Honorable Order of the Bath, a Member of Her Majesty's Most Honorable Privy Council, Governor and Commander-in-Chief of the Colony of New South Wales and its Dependencies.

TO ALL TO WHOM THESE PRESENTS SHALL COME, greeting:

WHEREAS WILLIAM M'LAUGHLIN, of Auckland, New Zealand, gentleman, hath by his Petition humbly represented to me that he is the author or designer of a certain invention or improvement in manufactures, that is to say, of an invention entitled "An Improved Hedge-trimmer, Land-clearer, and Harvesting Machine," which is more particularly described in the specification and the sheet of drawings which are hereunto annexed; and that he, the said Petitioner, hath deposited with the Honorable the Treasurer of the said Colony of New South Wales the sum of Twenty Pounds sterling, for defraying the expense of granting these Letters of Registration, as required by the Act of Council, sixteenth Victoria, number twenty-four; and hath humbly prayed that I would be pleased to grant Letters of Registration, whereby the exclusive enjoyment and advantage of the said invention or improvement might be secured to him for a period of fourteen years: And I, being willing to give encouragement to all inventions and improvements in the arts or manufactures which may be for the public good, and having received a report favourable to the prayer of the said Petition, from competent persons appointed by me to examine and consider the matters stated therein and to report thereon for my information, am pleased, with the advice of the Executive Council, and in exercise of the power and authority given to me by the said Act of Council, to grant, and do by these Letters of Registration grant unto the said William M'Laughlin, his executors, administrators, and assigns, the exclusive enjoyment and advantage of the said invention or improvement for and during the term of fourteen years from the date hereof; to have, hold, and exercise unto the said William M'Laughlin, his executors, administrators, and assigns, the exclusive enjoyment and advantage thereof for and during and unto the full end and term of fourteen years from the date of these presents next and immediately ensuing, and fully to be complete and ended: Provided always, that if the said William M'Laughlin shall not, within three days after the granting of these Letters of Registration, register the same in the proper office in the Supreme Court, at Sydney, in the said Colony of New South Wales, then these Letters of Registration, and all advantages whatsoever hereby granted, shall cease and become void.

In witness whereof, I have hereunto set my sign manual, and have caused the present Letters of Registration to be sealed with the seal of the said Colony of New South Wales, at Government House, Sydney, in New South Wales, this twenty-first day of August, in the year of our Lord one thousand eight hundred and eighty-four.

[I.S.]

AUGUSTUS LOFTUS.

Improved Hedge-trimmer, Land-clearer, and Harvesting Machine.

SPECIFICATION of WILLIAM M'LAUGHLIN, gentleman, of Auckland, New Zealand, for an invention entitled "An Improved Hedge-trimmer, Land-clearer, and Harvesting Machine."

FIG. 1 represents side elevation; fig. 2, ground plan of machine; fig. 3, another form of knife. The machine is carried on two wheels, W W, figs. 1 and 2; the cutting is done by the circular disc R revolving at a great speed, and is armed with cutting-knives, K K.

The motion of the disc R is given by bevel gearing communicating with the travelling or carrying-wheels W W. When it is necessary to clear ground, cut sugar-cane or other crops, the disc is placed horizontally, as drawn. When it is required to cut vertically, such as hedge-trimming, by altering the position of the bracket carrying the spindle S, until the spindle is in a proper position for the work to be accomplished, it will bring the disc round into any position for the work required. A dip can also be given to the cutting disc by altering the angle of the draw-pole L.

I claim the following advantages, which are possessed by this machine:—

1st. A revolving cutter; and I do not limit myself to any particular form. Such forms may be composed of long knives, without a disc, as shown on fig. 3, or a disc armed with any number of cutting parts, or as a plain disc with only knife-edges.

2nd. I do not limit myself to the form of the machine as shown on plans, or it may be greatly varied without in any way affecting the main principle of my invention.

Given under my hand and seal this eighth day of July, one thousand eight hundred and eighty-four.

W. M'LAUGHLIN.

This is the specification referred to in the annexed Letters of Registration granted to William M'Laughlin, this twenty-first day of August, A.D. 1884.

AUGUSTUS LOFTUS.

REPORT.

Sir,

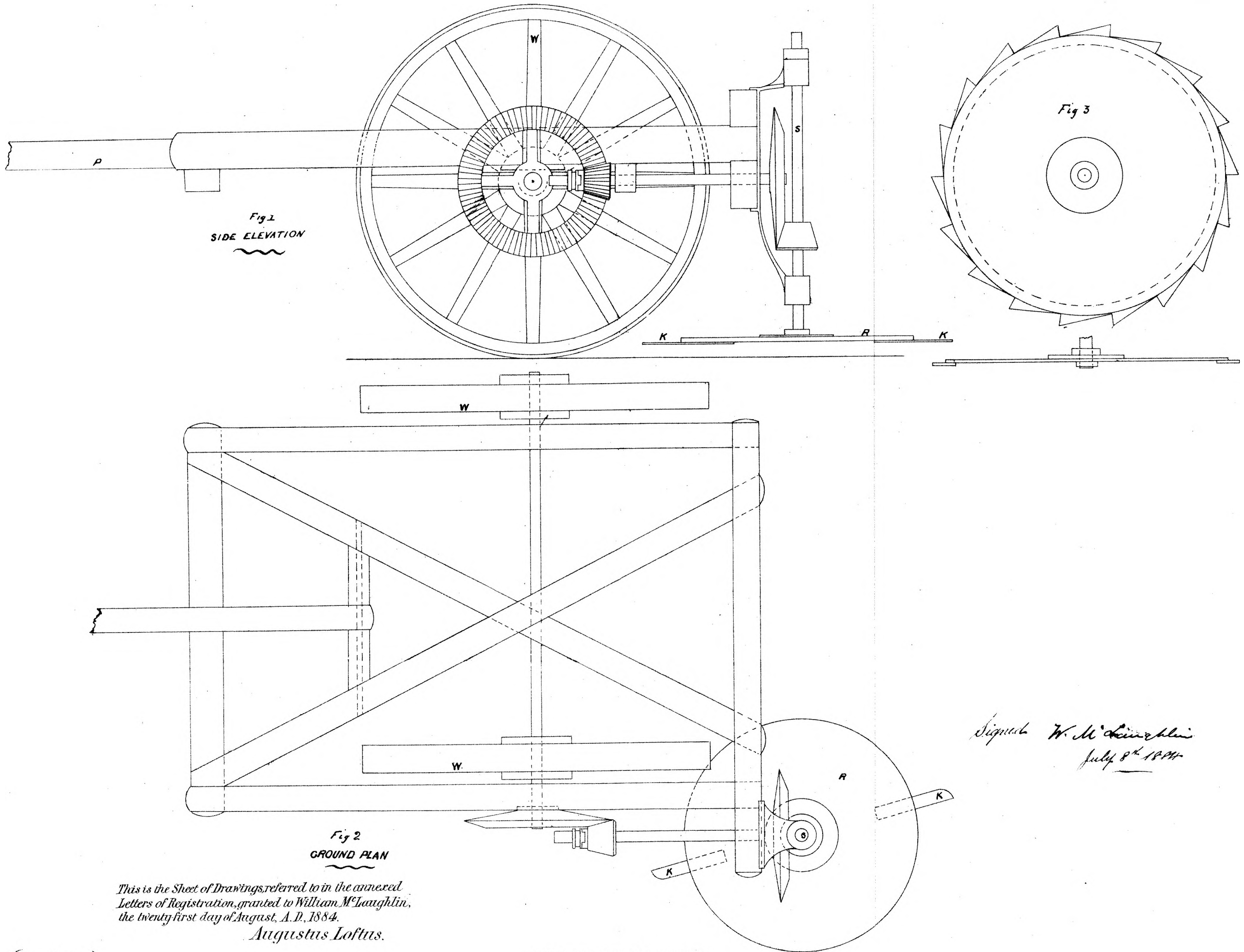
We do ourselves the honor to report, in reply to your blank cover of the 10th instant, transmitting Mr. William M'Laughlin's Petition for the registration of an invention entitled "An Improved Hedge-trimmer, Land-clearer, and Harvesting Machine," that we are of opinion the prayer of the Petitioner may be granted in terms of his specification, drawings, and claim.

We have, &c.,

GOTHER K. MANN.
EDMUND FOSBERY.

The Under Secretary of Justice.

[Drawings—one sheet.]



*Signed W. M. Laughtlin
July 8th 1884*

*This is the Sheet of Drawings, referred to in the annexed
Letters of Registration, granted to William M^e Laughtlin,
the twenty first day of August, A. D. 1884.
Augustus Loftus.*

(Sig: 245~)



A.D. 1884, 21st August. No. 1486.

AN IMPROVEMENT IN HANSOM CABS AND SIMILAR VEHICLES.

LETTERS OF REGISTRATION to Charles Ashburnham Floyd, for an Improvement in Hansom Cabs and similar Vehicles.

[Registered on the 22nd day of August, 1884, in pursuance of the Act 16 Vic. No. 24.]

By His Excellency THE RIGHT HONORABLE SIR AUGUSTUS WILLIAM FREDERICK SPENCER LOFTUS (commonly called LORD AUGUSTUS LOFTUS), Knight Grand Cross of the Most Honorable Order of the Bath, a Member of Her Majesty's Most Honorable Privy Council, Governor and Commander-in-Chief of the Colony of New South Wales and its Dependencies.

TO ALL TO WHOM THESE PRESENTS SHALL COME, greeting:

WHEREAS CHARLES ASHBURNHAM FLOYD, of Eastbourne, in the County of Sussex, England, hath by his Petition humbly represented to me that he is the author or designer of a certain invention or improvement in manufactures, that is to say, of an invention entitled "An Improvement in Hansom Cabs and similar Vehicles," which is more particularly described in the specification and the sheet of drawings which are hereunto annexed; and that he, the said Petitioner, hath deposited with the Honorable the Treasurer of the said Colony of New South Wales the sum of Twenty Pounds sterling, for defraying the expense of granting these Letters of Registration, as required by the Act of Council, sixteenth Victoria, number twenty-four; and hath humbly prayed that I would be pleased to grant Letters of Registration, whereby the exclusive enjoyment and advantage of the said invention or improvement might be secured to him for a period of fourteen years: And I, being willing to give encouragement to all inventions and improvements in the arts or manufactures which may be for the public good, and having received a report favourable to the prayer of the said Petition, from competent persons appointed by me to examine and consider the matters stated therein and to report thereon for my information, am pleased, with the advice of the Executive Council, and in exercise of the power and authority given to me by the said Act of Council, to grant, and do by these Letters of Registration grant unto the said Charles Ashburnham Floyd, his executors, administrators, and assigns, the exclusive enjoyment and advantage of the said invention or improvement, for and during the term of fourteen years from the date hereof; to have, hold, and exercise, unto the said Charles Ashburnham Floyd, his executors, administrators, and assigns, the exclusive enjoyment and advantage thereof, for and during and unto the full end and term of fourteen years from the date of these presents next and immediately ensuing, and fully to be complete and ended: Provided always, that if the said Charles Ashburnham Floyd shall not, within three days after the granting of these Letters of Registration, register the same in the proper office in the Supreme Court, at Sydney, in the said Colony of New South Wales, then these Letters of Registration, and all advantages whatsoever hereby granted, shall cease and become void.

In witness whereof, I have hereunto set my sign manual, and have caused the present Letters of Registration to be sealed with the seal of the said Colony of New South Wales, at Government House, Sydney, in New South Wales, this twenty-first day of August, in the year of our Lord one thousand eight hundred and eighty-four.

[L.S.]

AUGUSTUS LOFTUS.

An Improvement in Hansom Cabs and similar Vehicles.

SPECIFICATION of CHARLES ASHBURNHAM FLOYD, of Eastbourne, in the County of Sussex, England,
for an invention entitled "An Improvement in Hansom Cabs and similar Vehicles."

My invention relates to a construction and arrangement of the roof and hood of a hansom cab or vehicle of like formation, so as to provide simple and convenient means of sheltering the passenger from the weather or from sunshine or dust, without interfering with the comfort and ventilation of the interior of the vehicle. A similar construction and arrangement are applicable to vehicles of formation somewhat similar to that of a hansom cab, though made on a smaller scale, such, for example, as wheelchairs for invalids, perambulators for children, and the like. I also, in the case of a hansom cab constructed according to my invention, provide appliances for accommodating the umbrellas of passengers so as not to interfere with the comfort of the passengers, and also to ensure that they shall not forget to take them with them when they leave the vehicle. I will describe my invention, referring to the accompanying drawings.

Fig. 1 is a longitudinal section of the body of a hansom cab, and fig. 2 is a front view of the doors thereof. The roof of the cab A is made in the form of a circular arc struck from centre line C. In this line of centre, on a pin at each side of the cab within it, I mount a hood B, which can be advanced, as shown in fig. 1, or drawn back within the roof, as indicated by the dotted lines B', the hood being made like the roof A, circular in form and concentric with the roof, so that it slides freely within it. The hood may be retracted and held in any intermediate position by a strap or cord worked by either the driver or by the passenger. It may have glass panels, as shown at D in its top and at E in its sides, and these may, if desired, be provided with blinds or curtains. It will be seen that when the hood is advanced to its full extent, as shown in fig. 1, it effectually shelters the passenger, without interfering with the space within the vehicle and without preventing free ventilation.

For the purpose of accommodating umbrellas, which, if they happen to be wet, would be very objectionable within the vehicle, I make each of the handles F of the doors in the form of a ring large enough to admit of an umbrella being thrust down, so that its point rests in a cup G mounted on the door, with a spring that can yield a little downwards when it is subjected to the weight of the umbrella. Under the cup projects a pin H, which, when the cup is depressed, enters a hole in the floor of the cab and serves as a bolt fastening the door, so that the passenger cannot open the door for the purpose of leaving the vehicle until he has withdrawn the umbrella, and so has relieved the cup G of the weight. The spring of the cup, when relieved from the weight, withdraws the bolt H, and then the door can be opened.

Having thus described the nature of my invention, and in what manner the same is to be performed, I claim—

First—The construction of the roof and hood of a hansom cab, or other vehicle of similar form, in such a manner that the hood can be advanced or retracted concentrically with the roof, substantially as herein described.

Second—In a hansom cab, or vehicle of a similar form, the construction of the door-handle as a ring with a cup below it to hold an umbrella, the cup having a spring-bolt attached to it, arranged and operating substantially as and for the purposes herein set forth.

In witness whereof, I, the said Charles Ashburnham Floyd, have hereunto set my hand and seal, this nineteenth day of May, in the year of our Lord one thousand eight hundred and eighty-four.

C. ASHBURNHAM FLOYD.

This is the specification referred to in the annexed Letters of Registration granted to Charles Ashburnham Floyd, the twenty-first day of August, A.D. 1884.

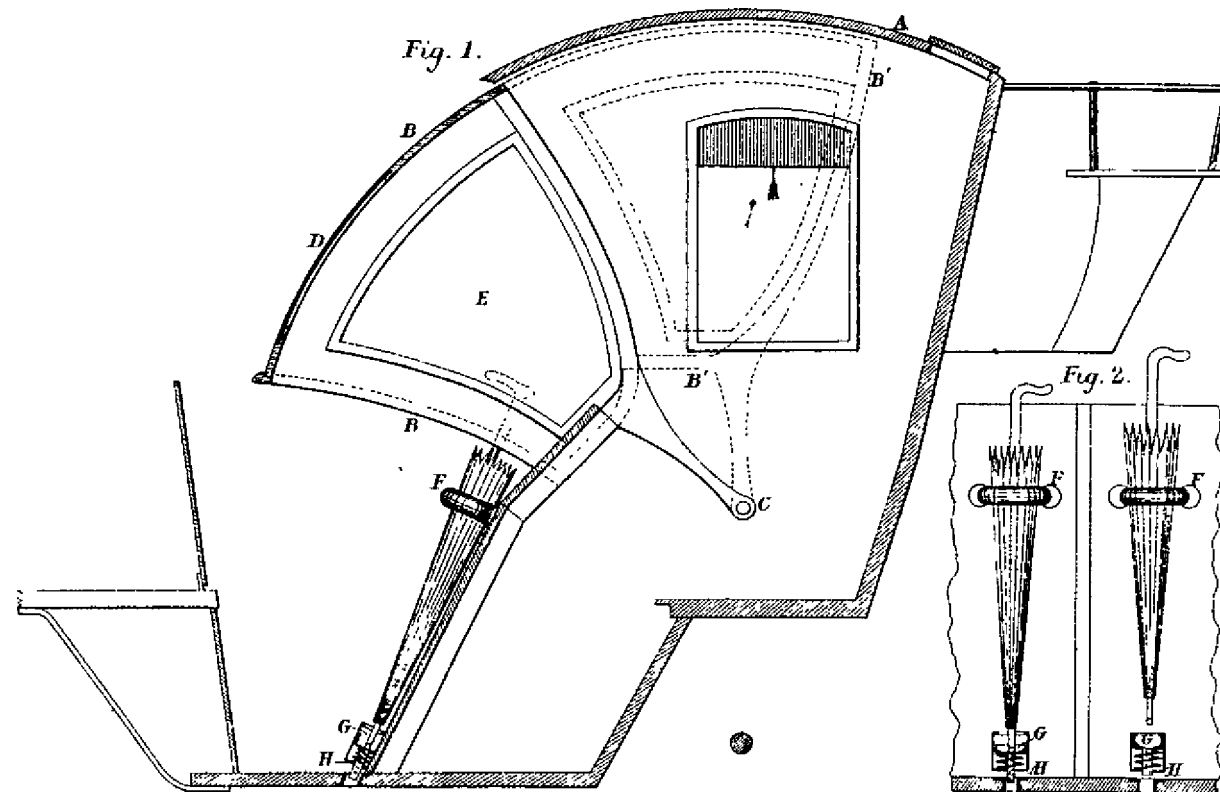
AUGUSTUS LOFTUS.

REPORT.

Sir,
The application of Mr. Charles Ashburnham Floyd for Letters of Registration for an invention entitled "An Improvement in Hansom Cabs and similar Vehicles," having been referred to us, we have examined the plans and specification accompanying the same, and have now the honor to report that we see no objection to the issue of Letters of Registration as prayed for.

We have, &c.,
JAMES BARNET.
EDMUND FOSBERY.

The Under Secretary of Justice.



*This is the Sheet of Drawings referred to in the annexed
Letters of Registration, granted to Charles Ashburnham
Floyd, the twenty-first day of August, A.D., 1884.*

Augustus Loftis.

(Sig: 245~).



A.D. 1884, 29th August. No. 1487.

AN IMPROVED NOSE-BAG FOR HORSES.

LETTERS OF REGISTRATION to Joshua Barker Carter, for an Improved
Nose-bag for Horses.

[Registered on the 30th day of August, 1884, in pursuance of the Act 16 Vic. No. 24.]

BY HIS EXCELLENCY THE RIGHT HONORABLE SIR AUGUSTUS WILLIAM FREDERICK SPENCER LOFTUS
(commonly called LORD AUGUSTUS LOFTUS), Knight Grand Cross of the Most Honorable Order of the
Bath, a Member of Her Majesty's Most Honorable Privy Council, Governor and Commander-in-Chief
of the Colony of New South Wales and its Dependencies.

TO ALL TO WHOM THESE PRESENTS SHALL COME, greeting :

WHEREAS JOSHUA BARKER CARTER, of No. 91, Bourke-street West, in the City of Melbourne, and Colony of Victoria, inventor, hath by his Petition humbly represented to me that he is the author or designer of a certain invention or improvement in manufactures, that is to say, of an invention entitled "An Improved Nose-bag for Horses," which is more particularly described in the specification, with drawing endorsed thereon, which is hereunto annexed; and that he, the said Petitioner, hath deposited with the Honorable the Treasurer of the said Colony of New South Wales the sum of Twenty Pounds sterling, for defraying the expense of granting these Letters of Registration, as required by the Act of Council, sixteenth Victoria, number twenty-four; and hath humbly prayed that I would be pleased to grant Letters of Registration, whereby the exclusive enjoyment and advantage of the said invention or improvement might be secured to him for a period of fourteen years: And I, being willing to give encouragement to all inventions and improvements in the arts or manufactures which may be for the public good, and having received a report favourable to the prayer of the said Petition, from competent persons appointed by me to examine and consider the matters stated therein and to report thereon for my information, am pleased, with the advice of the Executive Council, and in exercise of the power and authority given to me by the said Act of Council, to grant, and do by these Letters of Registration grant unto the said Joshua Barker Carter, his executors, administrators, and assigns, the exclusive enjoyment and advantage of the said invention or improvement, for and during the term of fourteen years from the date hereof; to have, hold, and exercise unto the said Joshua Barker Carter, his executors, administrators, and assigns, the exclusive enjoyment and advantage thereof, for and during and unto the full end and term of fourteen years from the date of these presents next and immediately ensuing, and fully to be complete and ended: Provided always, that if the said Joshua Barker Carter shall not, within three days after the granting of these Letters of Registration, register the same in the proper office in the Supreme Court, at Sydney, in the said Colony of New South Wales, then these Letters of Registration, and all advantages whatsoever hereby granted, shall cease and become void.

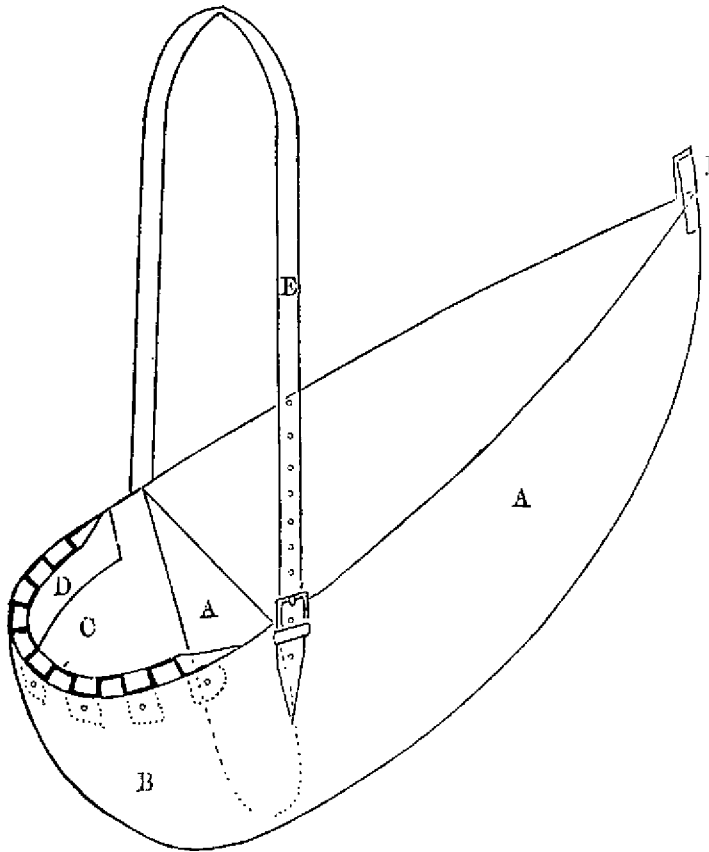
In witness whereof, I have hereunto set my sign manual, and have caused the present Letters of Registration to be sealed with the seal of the said Colony of New South Wales, at Government House, Sydney, in New South Wales, this twenty-ninth day of August, in the year of our Lord one thousand eight hundred and eighty-four.

[L.S.]

AUGUSTUS LOFTUS.

An Improved Nose-bag for Horses.

SPECIFICATION of JOSHUA BARKER CARTER, of No. 91, Bourke-street West, in the City of Melbourne, and Colony of Victoria, inventor, for an invention entitled "An Improved Nose-bag for Horses."



My improved nose-bag for horses has been designed for the purpose of enabling such animals to eat with greater comfort out of such contrivances and without deterioration to their health. It consists in so constructing said articles as to provide for a downward current of air near to the animal's nostrils, and for a gradual supply of the feed to that part of the bag where the horse is actually feeding. It may be made of canvas, or any other cheap and strong material, and has two straps—one to go over the horse's head, and the other to be suspended from, say, the turret of the saddle. This contrivance is clearly illustrated in the drawing in the margin hereof, where A is the feed reservoir, and A' the loose canvas flap between it and the actual feeding part of the bag B, where the animal puts his nose; C is, in this case, a bent strip of tin, fastened on the outside to the lip of the bag, and on the inside to a coating of cloth D, or other material which will not inconvenience the horse. This provides for the supply of fresh air and the escape of foul. E is a head-strap, and F a suspension strap for attachment, say, to the saddle-turret.

I do not confine myself to the precise method of constructing the ventilator C, as any contrivance which will admit of the passage of the foul air out, and of the fresh air in, will answer the purpose; but what I believe to be new, and therefore claim as my invention, is—

The improved nose-bag for horses, substantially as herein described and explained, and as illustrated in the sketch hereon.

In witness whereof, I, the said Joshua Barker Carter, have hereto set my hand and seal, this twelfth day of July, one thousand eight hundred and eighty-four.

J. B. CARTER.

Witness—

EDWARD WATERS,
Melbourne, Patent Agent.

This is the specification, with drawing endorsed thereon, referred to in the annexed Letters of Registration granted to Joshua Barker Carter, the twenty-ninth day of August, A.D. 1884.

AUGUSTUS LOFTUS.

REPORT.

Sir,

Sydney, 18 July, 1884.

We do ourselves the honor to return herewith the documents transmitted for our report with your blank cover communication, dated the 15th instant, 84-7,633, with reference to the Petition from Mr. Joshua Barker Carter, praying for Letters of Registration for an invention for "An Improved Nose-bag for Horses," and we have to state that we see no objection to the issue of the Letters of Registration asked for, in terms with the specification, drawing, and claims.

We have, &c.

EDMUND FOSBERY.
GOTHEK K. MANN.

The Under Secretary of Justice.



A.D. 1884, 29th August. No. 1488.

IM PROVED MACHINE, CONVERTIBLE INTO A WIRE-STRAINER OR AUGER.

LETTERS OF REGISTRATION to William Creed, for an Improved Machine, convertible into a Wire-strainer or Auger.

[Registered on the 30th day of August, 1884, in pursuance of the Act 16 Vic. No, 24.]

BY HIS EXCELLENCY THE RIGHT HONORABLE SIR AUGUSTUS WILLIAM FREDERICK SPENCER LOFTUS (commonly called LORD AUGUSTUS LOFTUS), Knight Grand Cross of the Most Honorable Order of the Bath, a Member of Her Majesty's Most Honorable Privy Council, Governor and Commander-in-Chief of the Colony of New South Wales and its Dependencies.

TO ALL TO WHOM THESE PRESENTS SHALL COME, greeting :

WHEREAS WILLIAM CREED, of Warratta, near Corowa, in the Colony of New South Wales, surveyor, hath by his Petition humbly represented to me that he is the author or designer of a certain invention or improvement in manufactures, that is to say, of an invention entitled "An Improved Machine, convertible into a Wire-strainer or Auger," which is more particularly described in the amended specification and the sheet of drawings which are hereunto annexed ; and that he, the said Petitioner, hath deposited with the Honorable the Treasurer of the said Colony of New South Wales the sum of Twenty Pounds sterling, for defraying the expense of granting these Letters of Registration, as required by the Act of Council, sixteenth Victoria, number twenty-four ; and hath humbly prayed that I would be pleased to grant Letters of Registration, whereby the exclusive enjoyment and advantage of the said invention or improvement might be secured to him for a period of fourteen years : And I, being willing to give encouragement to all inventions and improvements in the arts or manufactures which may be for the public good, and having received a report favourable to the prayer of the said Petition from competent persons appointed by me to examine and consider the matters stated therein and to report thereon for my information, am pleased, with the advice of the Executive Council, and in exercise of the power and authority given to me by the said Act of Council, to grant, and do by these Letters of Registration grant unto the said William Creed, his executors, administrators, and assigns, the exclusive enjoyment and advantage of the said invention or improvement, for and during the term of fourteen years from the date hereof ; to have, hold, and exercise unto the said William Creed, his executors, administrators, and assigns, the exclusive enjoyment and advantage thereof, for and during and unto the full end and term of fourteen years from the date of these presents next and immediately ensuing, and fully to be complete and ended : Provided always, that if the said William Creed shall not, within three days after the granting of these Letters of Registration, register the same in the proper office in the Supreme Court, at Sydney, in the said Colony of New South Wales, then these Letters of Registration, and all advantages whatsoever hereby granted, shall cease and become void.

In witness whereof, I have hereunto set my sign manual, and have caused the present Letters of Registration to be sealed with the seal of the said Colony of New South Wales, at Government House, Sydney, in New South Wales, this twenty-ninth day of August, in the year of our Lord one thousand eight hundred and eighty-four.

AUGUSTUS LOFTUS.

Improved Machine, convertible into a Wire-strainer or Auger.

SPECIFICATION of WILLIAM CREED, of Warrmatta, near Corowa, in the Colony of New South Wales, surveyor, for an invention entitled "An Improved Machine, convertible into a Wire-strainer or Auger."

My machine consists of a crank-spindle, the centre or crank portion of which is plain, for use as a handle, while the straight lengths, extending either way from the crank, have cut in them a right-handed screw or thread at the one end, and a left-handed screw or thread at the other. These screws each pass through suitably tapped nuts, having snugs formed on them on which to pivot the eccentric grippers, and also projections between which and the grippers the wire to be strained is compressed and held. In this construction the handle of the eccentric gripper will require to be made long enough (either in one length or by jointing it similar to a compass) to catch an adjacent wire, or, in the case of starting, to catch the ground below so as to form a resistance while screwing up or straining. An alternative construction consists in adding an arm to each nut, one of which terminates in a forked end, and the other is bent at right angles, forming a parallel bar to the screwed spindle and its end resting in the forked termination of the other arm. By this means the parallel bar can be held by hand, and so form a resistance without the aid of an adjacent wire. There may, if preferred, be a joint in the crank, so as to enable the machine to fold up.

To convert this machine into an auger, I provide a handle or knob and a socket attachment for an auger-bit, and it can then be used for boring the holes through the posts.

Referring to the drawings, fig. 1 is a plan, and fig. 2 an end view of my machine as a wire-strainer, with one of the alternative construction of same shown in dotted lines. Fig. 3 shows a single-ended, and fig. 4 a double-ended, wire-strainer, the latter being jointed at the crank-handle, and both of which may be converted into braces by the addition of the knob and socket, which are shown in section at figs. 5 and 6. In these figs., A is the crank or handle; B the right-handed and C the left-handed screw extension or spindle of same; B¹ the right-handed nut, having the lug B² and hook B³ thereon, and to which lug the eccentric lever B³ is pivoted at B¹; b is the projection against which the wire is compressed; C¹ is the left-handed nut, with its respective lug C², eccentric gripper C³, pivot C⁴, and projection c; D D are washers held on ends of screw-spindle by the screw-studs D¹ D¹, to prevent nuts from being screwed off; F is the wire between the grippers; G G¹ is the arm and parallel bar extension from lug B³; H is the arm extension from lug C², on the end of which arm is formed the fork H¹, which forms a guide for said parallel bar G¹.

In fig. 3, K is a swivel of the same outward form as the nut B¹ previously described, and held in position by the loose collar K¹, having the pin K² passing through it and its support, which also has the groove K³ in it for affixing the knob, and, at the other end, a hole is drilled at C², so as to fix on the socket, and C³ is the jointed extension of the gripper-arm.

In fig. 4 the knob and socket are shown affixed in position, the latter having the auger-bit E therein. A screw-joint, as shown, is formed in the crank-handle at A¹ for convenience in transport.

Fig. 5 shows the knob or handle F, held in position on the wire-strainer by the end of thumb-screw passing into the before referred to groove K³, and fig. 6 shows the auger-bit socket-piece G held on the wire-strainer by the end of thumb-screw G¹, passing into the before referred to hole C²; G² is the thumb-screw for securing the bit in its socket.

The mode of operation of my machine as a wire-strainer is as follows:—The machine is placed alongside any length of wire to be strained, and the wire placed in and compressed between each gripper and its resistance. The wire is then cut and bent back clear of the crank, which is then rotated with the result of drawing the two ends of the wire closer together, or straining it. When the strain is sufficient, the surplus wire is cut off, the ends joined, the gripper released, and the operation is completed.

When used as an auger for boring the holes in the posts, the nuts B¹ and C¹, with their attachments, are taken off, and the knob F and socket G, with its bit E, are affixed in their respective positions. Then the brace may be used in the ordinary way.

Having thus described the nature of my said invention, and the manner of performing same, I would have it understood that what I claim is—

First—The construction of wire-straining machines, consisting of a crank-spindle, jointed or not, and having a right-handed thread or screw cut or formed in it on the one side of the crank, and a left-handed screw or thread cut in it on the other, working through their respective nuts, and provided with suitable grippers, substantially as herein described and explained.

Second—The modification of such machine as herein described and explained, and as illustrated in fig. 3 of my drawings.

Third—The combination of either of the crank-spindles herein described with the handle or knob F and the socket-piece G for converting same into a boring-brace or auger, as herein described, and as illustrated in fig. 4 of my drawings.

Witness—

FRED. WALSH.

WM. CREED.

This is the specification referred to in the annexed Letters of Registration granted to William Creed, the twenty-ninth day of August, A.D. 1884.

AUGUSTUS LOFTUS.

REPORT.

Sir,

We do ourselves the honor to report, in reply to your blank cover of the 25th instant, No. 6,765, transmitting Mr. William Creed's Petition for the registration of an invention entitled "An Improved Wire-straining Machine," that we are of opinion that the prayer of Petitioner may be granted.

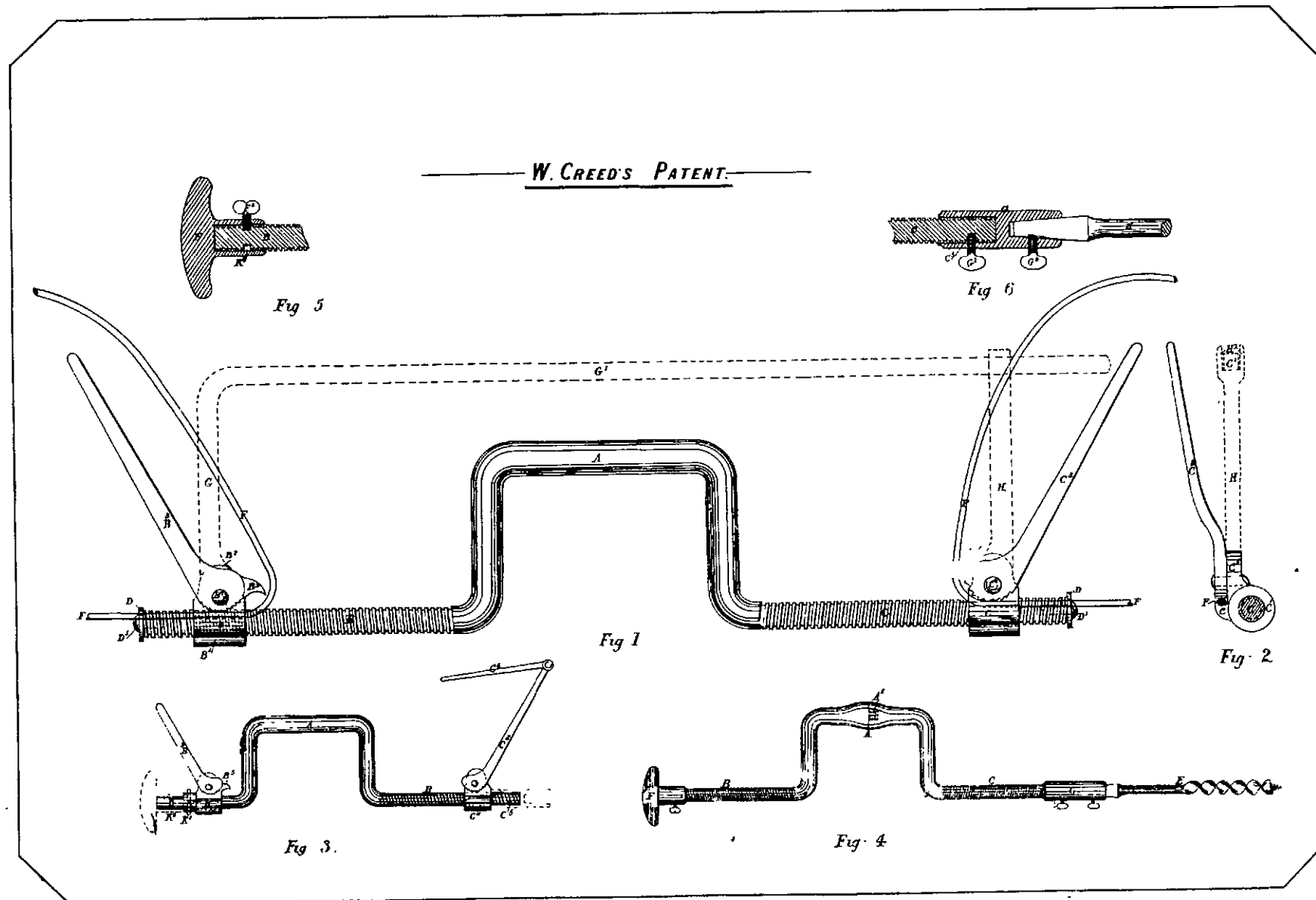
We have, &c.,

E. C. CRACKNELL.
GOTHER K. MANN.

The Under Secretary of Justice.

[Drawings—one sheet.]

Sydney, 30 June, 1884.



(Sig: 245-) This is the Sheet of Drawings referred to in the annexed Letters of Registration, granted to William Creed, the twenty ninth day of August, A. D., 1884.
Augustus Loftus.

PHOTO-LITHOGRAPHED AT THE GOVT. PRINTING OFFICE,
SYDNEY, NEW SOUTH WALES.



A.D. 1884, 29th August. No. 1489.

IMPROVEMENTS IN BOGIES.

LETTERS OF REGISTRATION to John Brown and Thomas Midelton, for Improvements in Bogies, parts of which are applicable to other Under-gear for Railway and Tramway Rolling Stock.

[Registered on the 30th day of August, 1884, in pursuance of the Act 16 Vic. No. 24.]

BY HIS EXCELLENCY THE RIGHT HONORABLE SIR AUGUSTUS WILLIAM FREDERICK SPENCER LOFTUS (commonly called LORD AUGUSTUS LOFTUS), Knight Grand Cross of the Most Honorable Order of the Bath, a Member of Her Majesty's Most Honorable Privy Council, Governor and Commander-in-Chief of the Colony of New South Wales and its Dependencies.

TO ALL TO WHOM THESE PRESENTS SHALL COME, greeting:

WHEREAS JOHN BROWN, of No. 42, Burnett-street, Redfern, near Sydney, in the Colony of New South Wales, and THOMAS MIDELTON, of No. 2, Codrington-street, Darlington, near Sydney aforesaid, mechanical engineers, have by their Petition humbly represented to me that they are the authors or designers of a certain invention or improvement in manufactures, that is to say, of an invention entitled "Improvements in Bogies, parts of which are applicable to other Under-gear for Railway and Tramway Rolling Stock," which is more particularly described in the specification and the sheet of drawings which are herewith annexed; and that they, the said Petitioners, have deposited with the Honorable the Treasurer of the said Colony of New South Wales the sum of Twenty Pounds sterling, for defraying the expense of granting these Letters of Registration, as required by the Act of Council, sixteenth Victoria, number twenty-four; and have humbly prayed that I would be pleased to grant Letters of Registration, whereby the exclusive enjoyment and advantage of the said invention or improvement might be secured to them for a period of fourteen years; And I, being willing to give encouragement to all inventions and improvements in the arts or manufactures which may be for the public good, and having received a report favourable to the prayer of the said Petition, from competent persons appointed by me to examine and consider the matters stated therein, and to report thereon for my information, am pleased, with the advice of the Executive Council, and in exercise of the power and authority given to me by the said Act of Council, to grant, and do by these Letters of Registration grant unto the said John Brown and Thomas Midelton, their executors, administrators, and assigns, the exclusive enjoyment and advantage of the said invention or improvement for and during the term of fourteen years from the date hereof; to have, hold, and exercise unto the said John Brown and Thomas Midelton, their executors, administrators, and assigns, the exclusive enjoyment and advantage thereof for and during and unto the full end and term of fourteen years from the date of these presents next and immediately ensuing, and fully to be complete and ended: Provided always that if the said John Brown and Thomas Midelton shall not, within three days after the granting of these Letters of Registration, register the same in the proper office in the Supreme Court, at Sydney, in the said Colony of New South Wales, then these Letters of Registration, and all advantages whatsoever hereby granted, shall cease and become void.

In witness whereof I have herewith set my sign manual, and have caused the present Letters of Registration, to be sealed with the seal of the said Colony of New South Wales, at Government House, Sydney, in New South Wales, this twenty-ninth day of August, in the year of our Lord one thousand eight hundred and eighty-four.

[L.s.]

AUGUSTUS LOFTUS.

Improvements in Bogies.

SPECIFICATION of JOHN BROWN, of No. 42, Burnett-street, Redfern, near Sydney, in the Colony of New South Wales, and THOMAS MIDDLETON, of No. 2, Codrington-street, Darlington, near Sydney aforesaid, mechanical engineers, for an invention entitled "Improvements in Bogies, parts of which are applicable to other Under-gear for Railway and Tramway Rolling Stock."

THIS invention has been designed principally for the purpose of making the bogies which support carriages or other railway or tramway rollingstock adapt themselves within certain limits to the various curves over which they may be travelling, that is to say, so that the axles of such bogies will be automatically "radiated" towards the centre of the curve by reason of the wheels thereon always being caused to travel parallel with the rails; or, in plain words, in passing over a curve the wheels upon the outer rail will extend their distance apart, while those on the inner rail will approach one another proportionately to the radius of the curve being "run" upon. Some of the parts designed in the carrying out of this invention may be applied to other methods of mounting wheels and axles.

Our improvements in bogies consist, first and principally, in jointing two pairs of wheels, each pair of which has a certain amount of independent play beneath the vehicle, about a central pin, unattached to the vehicle underframe, and in centring one part of the articulated connection thus formed to said underframe, at a predetermined distance from the said central pin, while the other part of the articulated connection is radially connected to the said underframe.

Our improvements consist, secondly, in a peculiar method of giving independent play to each pair of wheels; thirdly, in supporting the superincumbent weight of the vehicle directly or almost directly above the centre of the rail; fourthly, in the method of constructing the wheels and axles, each wheel on an axle having independent motion, that is, the revolution of one wheel on the axle is not governed by that of the other wheel on the same axle; fifthly, in transferring the superincumbent weight, preferably by fluid pressure, from off the journals of the axles on to the peripheries of the wheels, so as to form an efficient brake; and further in the particular combinations and combinations of parts hereinafter more clearly set forth.

In our improved bogie, the superincumbent weight of the vehicle is supported (with the intervention of the usual springs) by a longitudinal beam on either side, whose ends rest upon or in a groove on the top of the axle-boxes on that side of the bogie, and which ends have the required amount of play thereon or therein. The axle-boxes are tied together by guiding frames or rods, or what we term "axle-frames," which are jointed about a central pin, which we call the "bogie-pin." At a predetermined distance from this bogie-pin one of said axle-frames is centred upon the "king-bolt," which is supported from the vehicle by a transverse beam or frame. The other axle-frame is connected from its outer ends by links or radius bars to the vehicle underframe, to centres on either side of the king-bolt, and in its transverse support, or to one centre depending from the vehicle.

Our wheels we make "dished" shape, with a journal or hub in the concave portion, and we do not fasten them to the axle, which only assists, according to our method of mounting, to determine the gauge of the wheels. The said "journal-hubs" fit and revolve within the axle-boxes, and the axle passes through them, and has a nut on either end. The longitudinal bearing beam before mentioned rests upon the axle-boxes, and the weight which it carries is received by such boxes and the journals therein, at a point directly or almost directly above the centre of the rail.

The brake mechanism is supported above and by the axle-frames, the shoes, which are on the ends of a transverse beam, being held "off" the peripheries of the wheels by a spring within a brake cylinder, and applied by pressure (preferably fluid pressure) within such cylinder in any approved well-known manner.

But in order that our invention may be clearly understood, we will now describe the same with reference to the drawings hereto attached, in which figure 1 is a longitudinal elevation of a bogie constructed according to our said invention; figure 2 is a plan; figure 3 a longitudinal sectional elevation upon the centre line, omitting some parts; figure 4 is an end elevation; figure 5 a cross-section on the line *aa*, in figure 2; and figure 6 a cross-section on the line *bb* in same figure. In figure 2, for the sake of clearness, the brake mechanism is shown above but one pair of wheels, and in figures 4 and 5 it is omitted altogether.

A A are the wheels; B one axle (say of the leading wheels); C the other axle; D the longitudinal bearing beam; E the bogie pin; F the king-bolt; G links or radius bars, and H brake cylinders. A¹ A¹ are journal-hubs; A² concave web of wheels; B¹ and C¹ are nuts on ends of axles; B² and C² axle-boxes, and B³ and C³ grooves in covers thereof. B⁴ and C⁴ are the "axle-frames," constructed preferably of sheet or plate iron, bolted or riveted to the transverse channel irons B⁵ and C⁵, which hold the axle-boxes; D¹ are rests for vehicle under-frame; D² suspending links, and D³ springs; E¹ and F¹ are jaws, flanges, or strengthening pieces to make the joints at E and F; E² is friction piece, having longitudinal play; F² is transverse frame, or beam; G¹ are centre pins; G² brackets or distance pieces; H¹ brake beam; H² brake shoes; H³ plunger or piston; H⁴ spring; H⁵ piston rod, and H⁶ its foot and guide; H⁷ are cylinder standards, or supports from axle-frames.

In travelling over or passing around a curve the axle B is "radiated" or placed square or nearly square across the rails, or, in other words, the wheels are caused to travel parallel with the rails by the action of the rails upon the flanges of wheels A, which moves axle-frame B⁴ about the king-bolt F, and causes bogie pin E to move to one side of the centre line of the car, and the wheels A, on axle C, being centred upon bogie pin E, also become radiated by the links or radius bars G, whose centres move to one side of the centre line of the rails, and control the axle frame C⁴, and pull the axle C square or nearly square across the rails, thus dividing the radiation between the two pair of wheels. As the wheels on the inner rail of the curve have less distance to travel they have a less number of revolutions than those on the outer, and being free within the axle-boxes and upon the axles, this takes place without strain, and with a minimum of friction.

Pressure is supplied from an accumulator, or in any well-known manner, to cylinder H, and when desired, admitted upon piston H³, to compress spring H⁴, and force the beam H⁷, with shoes H² on to top of the peripheries of wheels A, against the supporting stays or standards H⁶; that is, the ends of the beam H¹ rest upon the wheels, and the piston lifts the weight of and upon the frames, &c., by means of the

the

Improvements in Bogies.

the said standards, which relieves the axle-boxes of the superincumbent weight of the car, and transfers it to the peripheries of the wheels A, and forms an efficient brake upon them. When the pressure is relieved the spring H² returns the beam H¹, with shoes H¹, to its normal position "off" the wheels.

Instead of the centre pins G¹, one pin in the centre attached to the car underframe would serve the same purpose, and the position of this is shown by dotted lines joining the centre line at G², in figure 2. The relative position of the bogie pin E and the king-bolt F are preferably determined by the length of the car under which they are placed, the former being generally placed in the centre of the bogie, and the latter at a distance from it, greater or smaller, as the car is longer or shorter, and the distance apart of centres G¹ of the radius bars or rods is likewise determined in the same proportion.

The ends of the longitudinal bearing beams D rest in grooves B² and C², on top of the axle-boxes, and have play within such by reason of their shape, as shown, and their sliding action, and it will be seen that by this arrangement the weight is directly received upon the journals or hubs of the wheels or "journal-hubs," and not by the axles, and it is received as nearly as possible above the point of resistance, that is, above the point of contact with the rails.

Figure 7 is a diagrammatic plan, illustrating the main principle of the radiating motion. *aa* is (say) one axle; *bb* other axle; *cc* centre line of car; *d* position of "bogie-pin;" *e* position of king-bolt; *ff* centres of radius bars or links; *f'* alternative common centre for same; and *gg* centre line of a railway curve of 80 feet radius.

Having thus described the nature of our invention, and the manner in which the same is to be performed, we would have it understood that we do not confine ourselves to any particular manner or mechanism for carrying our invention into practical effect; but what we believe to be novel, and therefore claim as our improvements in bogies, parts of which are applicable to other under-gear for railway and tramway rolling stock, is—

- First—Centring one member of a jointed connection between two pairs of wheels to the vehicle underframe at a distance from its said joint, the other member being radially connected to the said underframe, substantially as herein described and explained.
- Second—Supporting the superincumbent weight of the vehicle by or upon a longitudinal beam, resting upon the axle-boxes, substantially as herein described and explained.
- Third—Supporting the superincumbent weight of the vehicle upon the "journal-hubs" of the wheels, at or near to a point directly above the rail, substantially as herein described and explained.
- Fourth—Applying a brake to the wheels by transferring the weight off the bearings, the axles, &c., on to the peripheries of such wheels, substantially as herein described and explained.
- Fifth—The combination and arrangement of "independent" wheels A, loose upon the axle and within the axle-boxes, the axle-frames B¹ and C¹, the bogie-pin E, the king-bolt F, and radius bars or links G, substantially as herein described and explained, and as illustrated in the drawings.
- Sixth—The combination and arrangement of the beam H² and shoes H¹, with a pressure cylinder, H, supported directly upon or by the axle-boxes or their frames, substantially as herein described and explained, and as illustrated in the drawings.

In witness whereof we, the said John Brown and Thomas Midelton, have hereto set our hands and seals this seventh day of July, one thousand eight hundred and eighty-four.

JOHN BROWN.
THOS. MIDEULTON.

Witness—

FRED. WALSH,
Edward Watons' Patent Office, Sydney.

This is the specification referred to in the annexed Letters of Registration, granted to John Brown and Thomas Midelton, the twenty-ninth day of August, A.D. 1884.

AUGUSTUS LOFTUS.

REPORT.

Sir,

In reference to your B.C. of 7th instant, submitting a Petition from Messrs. Brown and Midelton, for Letters of Registration for an invention entitled "Improvements in Bogies, parts of which are applicable to other Under-gear for Railway and Tramway Rolling Stock," we have the honor to inform you that, having examined the plans and specification accompanying the Petition, we are of opinion the prayer of the Petitioners may be acceded to.

The Under Secretary of Justice.

Sydney, 17 July, 1884.

We have, &c.,
JOHN WHITTON.
E. O. MORIARTY.

BROWN & MIDELTON'S PATENT

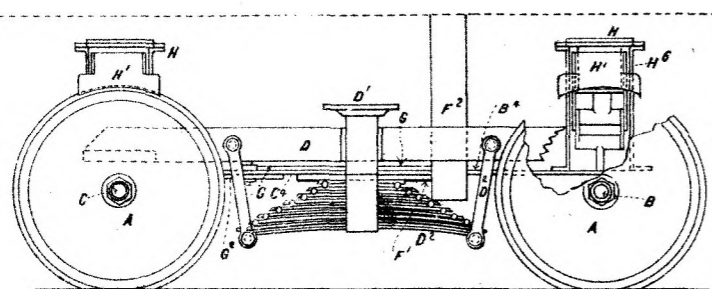


FIG. 1.

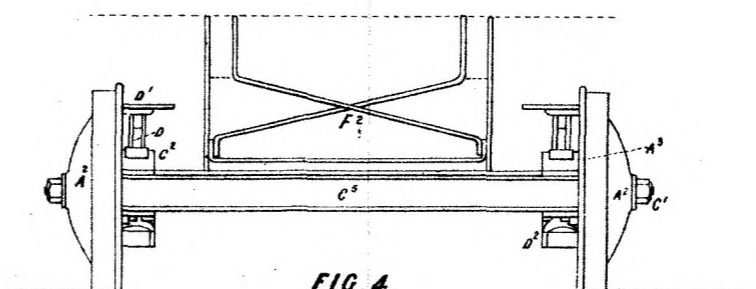


FIG. 4.

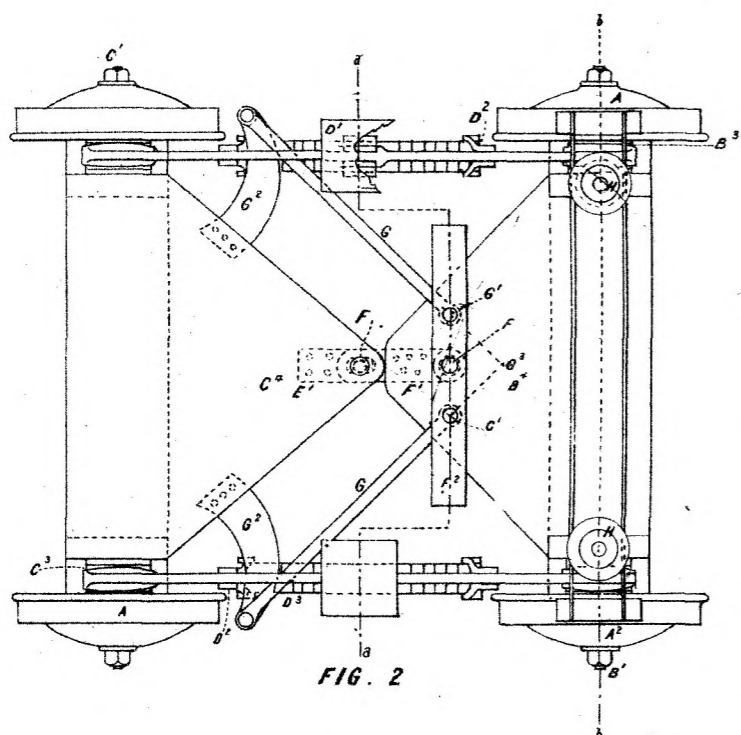
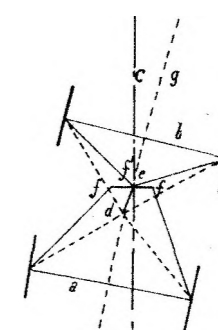


FIG. 2.

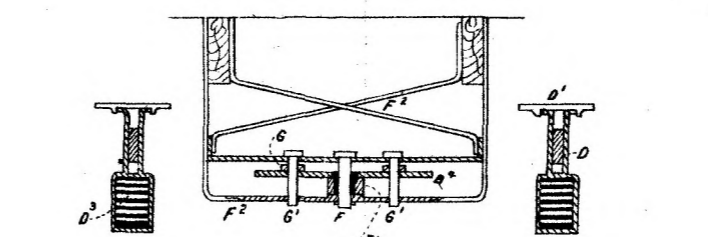


FIG. 5.

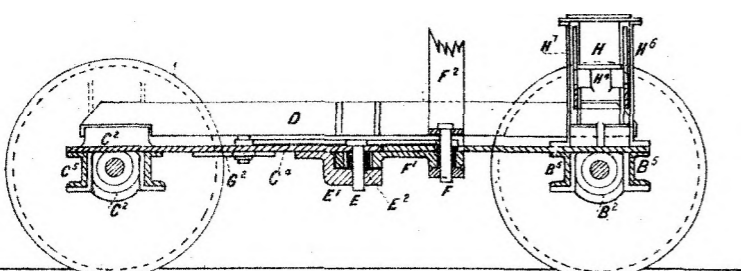


FIG. 3.

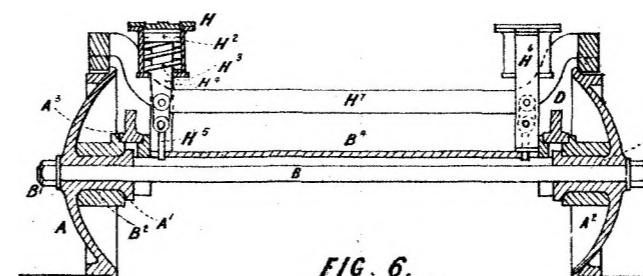


FIG. 6.

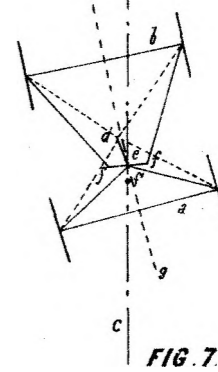


FIG. 7.

This is the Sheet of Drawings referred to in the annexed Letters of Registration, granted to John Brown and Thomas Midelton, the twenty ninth day of August, A.D., 1884.

Augustus Loftus.

(Sig: 245~)



A.D. 1884, 29th August. No. 1490.

IMPROVEMENTS IN SLEEPING-CARS.

LETTERS OF REGISTRATION to Carson Woods, for Improvements in
Sleeping-cars.

[Registered on the 30th day of August, 1884, in pursuance of the Act 16 Vic. No. 24.]

BY HIS EXCELLENCY THE RIGHT HONORABLE SIR AUGUSTUS WILLIAM FREDERICK SPENCER LOFTUS (commonly called LORD AUGUSTUS LOFTUS), Knight Grand Cross of the Most Honorable Order of the Bath, a Member of Her Majesty's Most Honorable Privy Council, Governor and Commander-in-Chief of the Colony of New South Wales and its Dependencies.

TO ALL TO WHOM THESE PRESENTS SHALL COME, greeting :

WHEREAS CARSON WOODS, of Sydney, in the Colony of New South Wales, agent and importer, hath by his Petition humbly represented to me that he is the author or designer of a certain invention or improvement in manufactures, that is to say, of an invention entitled "Improvements in Sleeping-cars," which is more particularly described in the specification and the sheet of drawings which are herewith annexed ; and that he, the said Petitioner, hath deposited with the Honorable the Treasurer of the said Colony of New South Wales the sum of Twenty Pounds sterling, for defraying the expense of granting these Letters of Registration, as required by the Act of Council, sixteenth Victoria, number twenty-four ; and hath humbly prayed that I would be pleased to grant Letters of Registration, whereby the exclusive enjoyment and advantage of the said invention or improvement might be secured to him for a period of fourteen years : And I, being willing to give encouragement to all inventions and improvements in the arts or manufactures which may be for the public good, and having received a report favourable to the prayer of the said Petition, from competent persons appointed by me to examine and consider the matters stated therein and to report thereon for my information, am pleased, with the advice of the Executive Council, and in exercise of the power and authority given to me by the said Act of Council, to grant, and do by these Letters of Registration grant unto the said Carson Woods, his executors, administrators, and assigns, the exclusive enjoyment and advantage of the said invention or improvement, for and during the term of fourteen years from the date hereof ; to have, hold, and exercise unto the said Carson Woods, his executors, administrators, and assigns, the exclusive enjoyment and advantage thereof, for and during and unto the full end and term of fourteen years from the date of these presents next and immediately ensuing, and fully to be complete and ended : Provided always, that if the said Carson Woods shall not, within three days after the granting of these Letters of Registration, register the same in the proper office in the Supreme Court, at Sydney, in the said Colony of New South Wales, then these Letters of Registration, and all advantages whatsoever hereby granted, shall cease and become void.

In witness whereof, I have hereunto set my sign manual, and have caused the present Letters of Registration to be sealed with the seal of the said Colony of New South Wales, at Government House, Sydney, in New South Wales, this twenty-ninth day of August, in the year of our Lord one thousand eight hundred and eighty-four.

[L.s.]

AUGUSTUS LOFTUS.

Improvements in Sleeping-cars.

SPECIFICATION of CARSON WOODS, of Sydney, in the Colony of New South Wales, agent and importer, the assignee of the inventor of an invention entitled "Improvements in Sleeping-cars."

THE object of my invention is to furnish railroad cars with berths so constructed and arranged that they may be folded up out of the way in preparing the cars for day use, and will not interfere with the ordinary use of the car.

Frames divided into two compartments by a central partition are hinged to the side walls of a car in such a way that they may be swung in against the said walls or swung out at right angles to them. And in combination with these hinged frames are arranged berths in such a way that the said berths may be placed in a vertical position within the said frames, or turned down into a horizontal position between two adjacent frames. With these I propose to construct the car-floor with recesses at right-angles to the side walls to receive the lower ends of the hinged frames when said frames are swung outward.

For full comprehension of the invention, reference must be had to the annexed drawings, in which fig. 1 is a longitudinal section of part of a car embodying my invention on the line *xx*, fig. 3, showing some of the berths arranged for use; fig. 2 is the same view as fig. 1, but showing the berths closed up; fig. 3 is a cross section on the line *yy*, figs. 1 and 2; fig. 4 shows an elevation of the support for the berth; fig. 5 a sectional view of the same; fig. 6 a separate view of the chair support when not in use. Similar letters of reference indicate corresponding parts.

A represents the floor, B the side walls, and C the roof of a car, in the construction of which parts there is nothing new.

*b*¹ are the windows, which are formed in the side walls B in the usual way, and in the spaces between them are hinged frames D, which during the day are turned in against the sides of the car, and form to all appearances part thereof, but, when it is desired to convert the car into a sleeper, are turned out at right-angles thereto, and secured in such position by pintles dropped into recesses *a*¹, formed in the floor A, to receive them, which recesses, when the frames D are turned in against the walls B, are closed by blocks *a*² fitting into them. The frames D are usually divided into two compartments by a central plate *d*, and into each of these compartments is fitted a berth E, with all bedding necessary therefor.

To the side edges of one end of each berth E are attached pins which enter longitudinal grooves in the inner surfaces of the side bars of the frames D, so that, by moving the upper end of each berth outward, it may be slid upward and turned down into a horizontal position, its free end entering the adjacent frame D, and resting upon stop pins *e*¹, attached to said frames.

The pivoted ends of the berths E rest upon spring stops *e*², attached to said frames D, which are so formed as to yield and allow said frame to be slid up or down when adjusting it into either position. In this way two berths are formed between each two frames D, as shown in figs. 1 and 3.

The bottoms of the berths E that are outward when the frames D are turned in against the walls B, are, as before mentioned, made similar to the walls of the car by panelling, as indicated in fig. 2.

I have shown in figs. 4 and 5 detailed views of the devices I prefer to use for securing the frames in place, either when swung out to carry the berths, or when turned in against the sides of the car. Brackets G are secured to the bottom of the frames, in which are journaled bearings rollers *h*, which travel on the floor of the car. Formed with the bracket, or secured to it, is a sleeve, H, in which slides a vertical bolt, G¹, to the upper end of which is pivoted a bell crank lever, G², having a handle projecting through a slot in the sleeve, and a locking tongue, G³. Locking openings, *hh*¹, are formed in the sleeve to receive this locking tongue, either when the bolt is drawn up (by means of the handle) into the sleeve, or when it is lowered, as shown in the drawing, to fit in sockets in the floor of the car.

In fig. 6 I have shown a rectangular chair support provided with means for securing it to the floor, and a place for attaching a chair seat of any desired construction. These supports, when the berths are made up, are detached from the floor and suspended from a support in the bottom of the berth frame.

Having thus described my invention, what I claim is as follows:—

First—In a sleeping-car, frames placed between the windows, holding the berths and bedding in a vertical position, and folding flat against sides of car, so as to leave a clear floor-area between their fronts.

Second—In a sleeping-car, frames hinged to the side of the car, either folded back flat against the same, or swung out and secured at right-angles thereto.

Third—In a sleeping-car, frames hinged to the side of the car, and either folding flat against the same, or swung out at right-angles thereto, in the first position, holding the berths and bedding vertically, and in the second, carrying the berths made up for the night.

In witness whereof, I, the said Carson Woods, have hereto set my hand and seal, this second day of July, one thousand eight hundred and eighty-four.

CARSON WOODS.

Witness—

EDGAR FUSSELL, Clerk to Edward Waters, Patent Agent, Sydney.

This is the specification referred to in the annexed Letters of Registration granted to Carson Woods, the twenty-ninth day of August, A.D., 1884.

AUGUSTUS LOFTUS.

REPORT.

Sir,

In reference to your B.C. of 4th instant, submitting a Petition from Mr. Carson Woods for Letters of Registration for an invention entitled "Improvements in Sleeping-cars," we have the honor to inform you, that having examined the plan and specification attached to the Petition, we are of opinion that the prayer of the Petitioner may be acceded to.

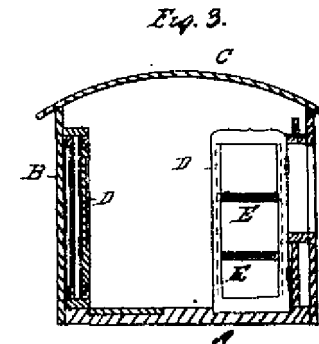
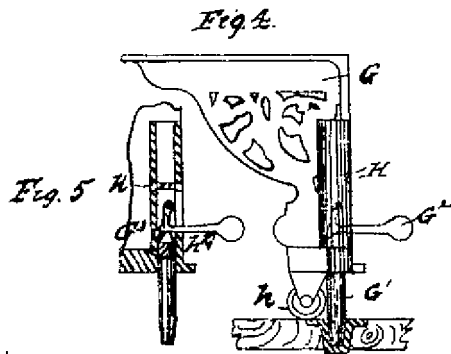
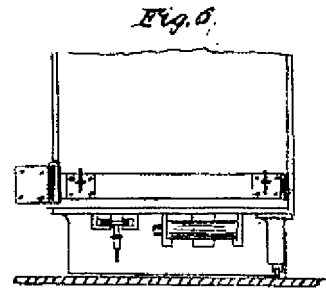
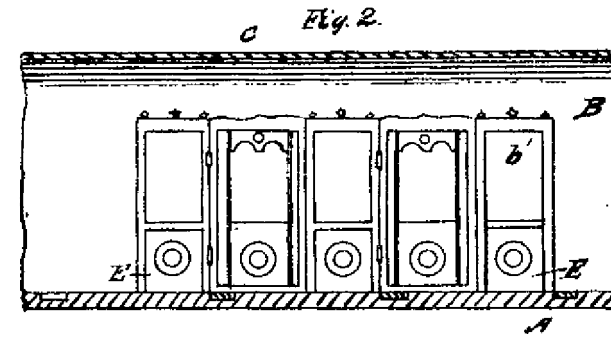
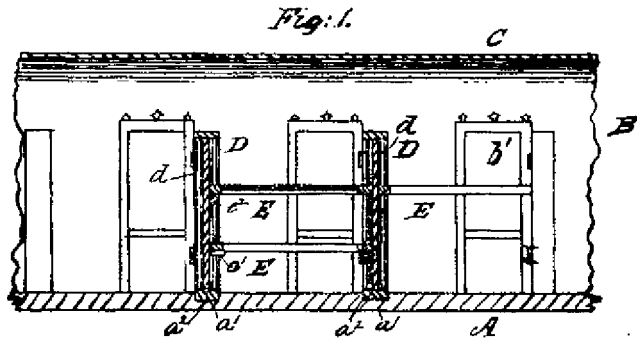
We have, &c.,

JOHN WHITTON.
E. O. MORIARTY.

The Under Secretary of Justice.

[Drawings—one sheet.]

Sydney, 17th July, 1884.



(Sig. 245~)

This is the Sheet of Drawings referred to in the annexed Letters of Registration, granted to Carson Woods, the twenty ninth day of August. A. D. 1884.

Augustus Loftus.



A.D. 1884, 29th August. No. 1491.

AN IMPROVED PROCESS AND APPARATUS FOR SEPARATING AND TREATING METALS, &c.

LETTERS OF REGISTRATION to Henry Renner Cassel, for an improved Process and Apparatus for separating and treating Metals, and extracting them from Ores, Mattes, or all other substances containing them, by means of Electrolysis, part of which invention is also applicable for other purposes.

[Registered on the 30th day of August, 1884, in pursuance of the Act 16 Vic. No. 24.]

BY HIS EXCELLENCY THE RIGHT HONORABLE SIR AUGUSTUS WILLIAM FREDERICK SPENCER LOFTUS (commonly called LORD AUGUSTUS LOFTUS), Knight Grand Cross of the Most Honorable Order of the Bath, a Member of Her Majesty's Most Honorable Privy Council, Governor and Commander-in-Chief of the Colony of New South Wales and its Dependencies.

TO ALL TO WHOM THESE PRESENTS SHALL COME, greeting :

WHEREAS HENRY RENNER CASSEL, of the City and State of New York, United States of America, and 52, Chancery Lane, London, in the county of Middlesex, England, electrician, hath by his Petition humbly represented to me that he is the author or designer of a certain invention or improvement in manufactures, that is to say, of an invention entitled "An improved Process and Apparatus for separating and treating Metals, and extracting them from Ores, Mattes, or all other substances containing them, by means of Electrolysis, part of which invention is also applicable for other purposes," which is more particularly described in the specification and the sheet of drawings which are hereunto annexed ; and that he, the said Petitioner, hath deposited with the Honorable the Treasurer of the said Colony of New South Wales the sum of Twenty Pounds sterling, for defraying the expense of granting these Letters of Registration, as required by the Act of Council, sixteenth Victoria, number twenty-four ; and hath humbly prayed that I would be pleased to grant Letters of Registration, whereby the exclusive enjoyment and advantage of the said invention or improvement might be secured to him for a period of fourteen years : And I, being willing to give encouragement to all inventions and improvements in the arts or manufactures which may be for the public good, and having received a report favourable to the prayer of the said Petition, from competent persons appointed by me to examine and consider the matters stated therein and to report thereon for my information, am pleased, with the advice of the Executive Council, and in exercise of the power and authority given to me by the said Act of Council, to grant, and do by these Letters of Registration grant unto the said Henry Renner Cassel, his executors, administrators, and assigns, the exclusive enjoyment and advantage of the said invention or improvement, for and during the term of fourteen years from the date hereof ; to have, hold, and exercise unto the said Henry Renner Cassel, his executors, administrators, and assigns, the exclusive enjoyment and advantage thereof, for and during and unto the full end and term of fourteen years from the date of these presents next and immediately ensuing, and fully to be complete and ended : Provided always, that if the said Henry Renner Cassel shall not, within three days after the granting of these Letters of Registration, register the same in the proper office in the Supreme Court, at Sydney, in the said Colony of New South Wales, then these Letters of Registration, and all advantages whatsoever hereby granted, shall cease and become void.

In witness whereof, I have hereunto set my sign manual, and have caused the present Letters of Registration to be sealed with the seal of the said Colony of New South Wales, at Government House, Sydney, in New South Wales, this twenty-ninth day of August, in the year of our Lord one thousand eight hundred and eighty-four.

[L.s.]

AUGUSTUS LOFTUS.

An improved Process and Apparatus for separating and treating Metals, &c.

SPECIFICATION of HENRY RENNER CASSEL, of the City and State of New York, United States of America, and 52, Chancery Lane, London, in the county of Middlesex, England, electrician, for an invention entitled "An improved Process and Apparatus for separating and treating Metals, and extracting them from Ores, Mattes, or all other substances containing them, by means of Electrolysis, part of which invention is also applicable for other purposes."

METALS, mattes, and especially gold ores, can easily be treated by means of electrolysis, and the finer metals extracted therefrom, provided a proper solvent be used, and a suitable apparatus be adopted for the purpose.

It is well known that chlorine or bromine will attack all metals, and that the finely divided gold in the ores is readily converted into chloride or bromide when in presence of these elements, and it is also well known that the action of nascent chlorine is much more rapid and effective than when separately generated. Any salt or acid in solution yielding under electrolytic decomposition nascent chlorine (like chloride of sodium, for instance, or sea water), are excellent electrolytes and solvents of the metals, and when used for this purpose together with my apparatus will rapidly dissolve the metals and more especially the gold.

The apparatus I use in connection with a dynamo machine or other source of electricity in this process may be of various forms, sizes, or construction, such apparatus being made either with the object of dissolving the metal and keeping it in solution, or with the object of depositing the dissolved metal at the negative pole.

For the purpose of keeping the metals in solution I interpose between the poles a porous material through which the current penetrates, but which prevents the dissolved metals from reaching the negative pole, and thus acts like a barrier to the metals in solution; porous clay, wood, plaster of Paris, or any other suitable material may be employed for this purpose.

When the gold is to be allowed to reach the negative pole precaution must be taken that the minerals do not reach the cathode, and for this purpose I interpose asbestos or other suitable material capable of acting as a filter.

If a solution of chloride of sodium is electrolyzed in such an apparatus, the chlorine being an anion is generated at the positive pole or anode, and consequently the metals or ores to be treated must be placed in the positive or anode compartment. The ores must be in a powdered state, otherwise the chlorine will not be able to attack the metals contained therein, and for the purpose of easily and practically treating the ores and extracting especially the gold therefrom in a rapid manner, it is essentially necessary that the chlorine when generated penetrates the whole mass, and is enabled to reach every particle of metal contained in the ore. To effect this it is necessary that the powdered ore or substance containing the metals should be continuously kept in motion by stirring or otherwise, and I therefore place stirrers in the positive compartment of the apparatus; or the apparatus may be constructed so that the positive compartment itself is made to revolve either upon an axis, or kept in motion by other means. These stirrers may be made of wood, or other non-conductive material, but I prefer to make them conductive and connect them with the dynamo machine or other source of electricity, so as to form the anode or positive pole. Plumbago or carbon is the best material for that purpose. It does not matter in what shape or manner these stirrers are constructed, so long as they keep the powdered mass in motion, but I prefer to arrange them in the form of a paddle wheel or around an axle, which upon being turned stirs up the whole mass.

The object of my invention is to dissolve the metals in a solution, which under electrolytic decomposition yields chlorine, in an apparatus in which either the metals in solution are prevented from reaching the negative pole, or in which the minerals or other substances are prevented from reaching it, and in the positive compartment of which are arranged stirrers, preferably forming the positive pole, which stirrers keep the whole mass in motion, and thus enable the chlorine to attack and convert it into chlorides any of the metals contained in the ores or substances to be treated.

I will now fully describe several forms of apparatus to be used for the above purpose, but do not restrict myself to them alone, the principle of my invention being present when any solution is used, which under electrolytic decomposition yields chlorine at the anode, in any apparatus in which anodes and cathodes are separated by a porous material, or by asbestos or other suitable material capable of acting like a filter, for the purpose described, thus forming an anode and a cathode compartment; or in which the anode and cathode compartments consist of separate vessels suitably connected as hereinafter described, the ore to be treated being always placed in the anode compartment and kept in motion either by stirrers, preferably made of graphite or carbon, or by making the anode compartment revolve, or is otherwise kept in motion for the purpose of enabling the chlorine to easily reach every particle of the metals contained in the ores or other substances to be treated.

Figure 1 of the drawings is a complete apparatus in which the positive compartment A is made in shape of a drum which is placed in tank B, and made to revolve on its own axis A'. The drum itself (which may be round, as shown in figures 1, 2, 5, and 6, or of polygonal form, as shown in figure 3, or other suitable form) is preferably made of wood, into which is inserted a suitable porous material, such as porous clay, for instance (as shown in figures 3 and 4), or the whole drum may be made of a porous material, or of sufficiently porous wood. The porous material may be arranged either all round the drum, or in the sides, or both, the whole being made as watertight as possible. An opening must be provided for the purpose of emptying and filling the drum. This opening must naturally be closed watertight, the cover being fastened preferably with screws, or any other means, and rubber strips may be used to prevent any leakage. Inside of this drum I place a convenient number of rods or plates of carbon or graphite, and I prefer to place them all round the inner circumference, as shown in figure 5, or they may be placed in any other convenient manner. To fix the carbons as solidly as possible I prefer to have them long enough to protrude through the sides of the drum, and a tight joint may be made with marine glue or otherwise. When thus made long enough they are easily connected outside with one another, and with the positive pole by copper or other metal caps, or by wire, or both (as shown in figures 2 and 6), which must afterwards be well insulated. The sides of the drum may also be made of suitable metals, and the carbons fixed therein, the metal being afterwards well insulated; this, however, is not so convenient, wood being preferable. The protruding carbons must also be well insulated.

Into

An improved Process and Apparatus for separating and treating Metals, &c.

Into this drum is placed the ore or substance to be treated, together with a suitable solution, such as chloride of sodium, for instance, and when properly closed and connected with the dynamo machine, the drum is made to revolve upon its own axis; the ores will then be continuously thrown upon the carbons, and the chlorine generated in the drum will be enabled to reach every particle of metal and convert it into a chloride. To connect the drum with the dynamo I insert in the axle *A'* outside the drum (as indicated in figure 6) a thick copper wire or rod, *E*, which must be connected with the carbons, and around this rod I place a copper spiral, *F*, which is connected with the dynamo machine. This spiral allows the drum to revolve freely, and ensures good contact, but any other convenient connection with the dynamo may be made.

The tank *B*, figure 1, filled with a proper solution, forms the negative compartment, and is provided with a cathode, *C*, either of carbon or metal. This tank may be round, square, or of other suitable form, and the drum is placed therein either with its axis horizontal, as indicated, or vertical or otherwise.

If too much chlorine is generated it may cause an explosion in the drum, and to prevent this I provide a small tap, *D* (figure 1), which from time to time may be opened to allow the chlorine to escape.

Figure 7 shows an apparatus on the same principle, but of different construction, in which instead of the drum I revolve the carbons which are arranged in the form of a paddle-wheel. The porous partition *H*, which in practice I prefer to make in a half circular form (although any other form may be adopted), is fitted tightly between two wooden or other boards, *G, G*, and the whole is placed in a suitable tank filled with solution and provided with the necessary cathode, *C*, as in the arrangement above described, so that the porous partition divides the anode from the cathode, and into the anode compartment thus formed are placed the ores to be treated, together with the necessary solution, and also the positive pole, preferably made of carbon or graphite, and fixed as in the former case between two wooden or other boards in form of a paddle-wheel, and connected with each other and the dynamo in the same manner as indicated in the first case. When thus properly connected and made to revolve upon its own axis, it will stir the ores and enable the chlorine to convert the metals into chlorides.

Instead of the paddle-wheel form, the graphite or carbon may be arranged around the axle or otherwise, the object always being to well stir up the mass. Instead of the half circular form of the porous partition, a circular porous partition may be used, closed at the bottom and open at the top, and the carbons arranged in a convenient manner to stir up the mass, the principle always being the same; or the circular porous partition may be made to revolve.

I prefer to place the positive pole in the inner compartment, but this is not essentially necessary since the ores may also be treated in the outer compartment, in which case the stirrers must also be arranged therein in a convenient and suitable manner; or the whole outer compartment may be made of carbon or plumbago, or lined therewith and connected with the dynamo machine, thus forming the positive pole, but stirrers must always be used.

The stirrers may, if desired, be mounted on a rod, as shown in figures 10, 11, and 12, and made to project into the mass of ore or other substance contained in the anode compartment, the rod being cranked outside the anode compartment for the purpose of causing the stirrers to revolve, or they may be caused to revolve by any other suitable means.

The apparatus to be used when the gold is to be deposited upon the negative pole may be of similar construction as those above described, but instead of the porous material, asbestos must be used or a similar suitable material which will return the materials or the greater part thereof, but which will permit the dissolved gold to pass through it. Care must be taken to use for this purpose a material which is not easily destroyed by the chlorine or acids which are generated during the operation, asbestos or glass wool being best adapted for the purpose.

The apparatus shown in figure 13 will enable the manner in which I effect this object to be thoroughly understood.

In figure 13, *A* is a perforated frame made of wood or other suitable material, around which asbestos, cloth, or wool, or other suitable material, *E*, is fastened in any convenient manner, such material being dense enough to retain as much of the minerals as possible. This asbestos or other partition forms a cell closed at the bottom, which is placed into a tank, *B*. The positive pole *C* (preferably made in the form of a stirrer) is placed inside the cell *A*, and the negative pole *D* outside and around the cell *A*. The ore is placed inside the cell *A*, and the apparatus filled with the necessary solution. When connected with a battery or other source of electricity, the dissolved metals will go through the interstices of the asbestos to the negative pole *D*, and be there precipitated. The stirrers may be made of any convenient shape.

Figure 14 shows another form of apparatus in which the ores may also be treated, although not so effectively as in those above described. Two vessels or vats, *A* and *B*, are placed close to and are connected with each other by means of a syphon, *a*, or by means of a pipe, *b*, preferably placed as high as possible, or by means of asbestos or any material which has the quality of retaining or conducting liquids by capillarity. Instead of the separate vats shown, one vat with a partition may be used, one compartment being for the positive pole *C* (preferably in the form of stirrers), and one for the negative pole *D*; or three or more separate vats may be employed, or a long vat partitioned off to form the necessary compartments for the positive and negative poles.

The vats or compartments containing the positive and negative poles instead of being connected together directly may be connected by intermediate vats or compartments, and the syphons, tubes, or suitable material capable of conducting liquids by capillarity.

Another form of apparatus may be made by placing in a tank a false bottom, made either of perforated wood or other suitable material, over which asbestos or slag wool, or any other convenient material is placed; but it is unnecessary to describe the various forms of apparatus that may be made, since any form of apparatus in which the anode compartment is separated from the cathode compartment may be employed in the manner and for the purposes above described.

Several of the above described apparatus may be placed in a circuit, care being taken that the electro-motive force be sufficient to overcome the resistance in the circuit. According to the richness of the ores or substances under treatment the solution will become more or less saturated, and (in the case where the

An improved Process and Apparatus for separating and treating Metals, &c.

the dissolved metals are prevented from reaching the negative pole) when fully saturated, or before, the solution is filtered off, and the metals may be precipitated by proper reagents.

When rebellious or refractory gold ores and concentrates (such as pyrites, for example) are treated as above described, a secondary action takes place and prevents the extraction of the gold contained in the ore. The reason of this is that by this secondary action hydrochloric and hypochlorous are formed and attach any compound of iron in the ore, changing it into a proto salt, and this proto salt immediately precipitates the gold in solution as fast as it is formed. The presence of free acid is further objectionable, as it also attacks any antimony, arsenic, or other rebellious or refractory elements contained in the ore. In order to prevent this I propose to add to the solution, a substance which will neutralize the acids as soon as they are formed, but which will not precipitate the gold. Since no free acid can exist in the presence of such a substance, any compound of iron contained in the ore will not be attacked, and its proto salt cannot, therefore, be formed, so that the gold consequently will not be precipitated and can easily be extracted from the ore. Further, the other refractory elements present in the ore will also remain unaffected, so that it will be unnecessary to first furnace or roast the ore for the purpose of eliminating the rebellious or refractory elements.

The substance I propose to use is lime, but any suitable alkaline earth or other chemical compound or element for which the acids have a stronger affinity than for the compounds of iron in the ores, but which will not precipitate gold, may be employed. Or I may use a solution which will itself, by electrolytical decomposition, yield a base capable when free of neutralizing the acids formed, but which will not precipitate the gold.

This employment of lime or other substance capable of neutralizing acids generated during the electrolyzing of a solution capable of yielding chlorine, may be adopted in any other form of apparatus for such purpose than those above described.

Chloride of sodium or any chemical in solution capable of generating chlorine by electrolytical decomposition together with any of the above described apparatus, or a modification thereof, may be used with great advantage for bleaching purposes, but the anode or positive pole must be covered with an open or perforated framework to prevent the fabrics, or other materials to be bleached, from coming in contact with the anode itself. The advantages of using such apparatus for bleaching purposes are that the caustic hydrate collects at the negative pole, and has consequently no detrimental effect on the fabrics or other material to be bleached, which is placed in the positive or anode compartment; further, the degree of strength and also the quantity of chlorine generated at the positive pole can easily be regulated by employing a smaller or greater electric current, or a solution of varying strength, or both; and finally, the generation of the chlorine may be instantly stopped by disconnecting the apparatus from the source of electricity.

Having thus described the nature of my said invention, and a suitable manner in which the same may be carried into effect, I wish it to be understood that what I claim is:—

1. The process for treating metals, ores, and especially auriferous compounds, by means of chlorine generated by electrolyzing a solution of chlorine of sodium or an equivalent solution capable of yielding chlorine under electrolytical decomposition, in an apparatus in which a porous material is arranged to form anode and cathode cells, in the anode cell of which the ores are continuously kept in motion, as and for the purpose specified.
2. The process for treating metals, ores, and especially auriferous compounds, which consists in dissolving the metals in a solution yielding chlorine under electrolytical decomposition, in keeping the compounds under treatment in motion by stirring or otherwise, and in preventing the dissolved metals which are in the negative pole, by interposing between the electrodes a porous material as described.
3. In the process described, an apparatus in which a porous material is arranged between the electrodes to form anode and cathode compartments, in the anode compartment of which the compounds are placed together with stirrers and a solution capable of yielding chlorine under electrolytical decomposition, as and for the purpose specified.
4. In a process as described, the use of a drum with positive poles arranged in the manner and for the purpose specified.
5. In the process described the apparatus, whereby the minerals in the ores or other substances under treatment are retained by asbestos or other suitable material capable of acting as a filter, whilst the metals dissolved by electrolytical action are freely allowed to pass through such material to be deposited at the negative pole, the ores or other substances being continuously kept in motion by stirring or otherwise, all substantially as herein specified.
6. In the process described, the apparatus consisting of two or more vats or compartments for the positive and negative poles, such vats or compartments being connected together (either directly or not) by syphons or pipes, or by asbestos or other suitable material capable of retaining or conducting liquids by capillarity, substantially as herein specified.
7. In the apparatus described, the use of stirrers of suitable material, conductive or not, in combination with carbon positive poles, for the purpose herein specified.
8. In the apparatus described, the anode pole made of carbon or plumbago and arranged as stirrers, in the manner and for the purpose specified.
9. The employment in the process described for the treatment of gold ores, or other auriferous substances, and more especially rebellious or refractory gold ores and concentrates of lime or any suitable alkaline earth or other chemical compound or element, for which any acids generated during the electrolytical action have a stronger affinity than for the compounds of iron in the ore, but which will not precipitate gold, or of a solution which itself under electrolytical decomposition will yield such a base, substantially for the purpose specified.
10. The process and apparatus for bleaching fabrics and other substances, which consists in electrolyzing a solution capable of generating chlorine under electrolytical decomposition, in an apparatus in which the fabrics or other substances are placed in the anode compartment, separated from the cathode compartment, either by a porous partition or by asbestos or other suitable

An improved Process and Apparatus for separating and treating Metals, &c.

suitable material, and are kept from coming in contact with the positive pole by a perforated or open framework, all substantially as herein described.

In witness whereof, I, the said Henry Renner Cassel, have hereunto set my hand and seal, this twenty-first day of March, one thousand eight hundred and eighty-four.

HENRY RENNER CASSEL.

Signed, sealed, and delivered by the said Henry Renner Cassel, in the presence of HERBERT JOHN ALLISON.

This is the specification referred to in the annexed Letters of Registration granted to Henry Renner Cassel, the twenty-ninth day of August, A.D. 1884.

AUGUSTUS LOFTUS.

REPORT.

Sir,

In the matter of the application of Mr. H. R. Cassel for Letters of Registration for "An improved Process and Apparatus for separating and heating Metals and extracting them from ores, &c., by means of Electrolysis," which has been referred to us, we have examined the specification and drawings accompanying the same, and have now the honor to report that we see no objection to the issue of Letters of Registration as prayed for.

Sydney, 10 May, 1884.

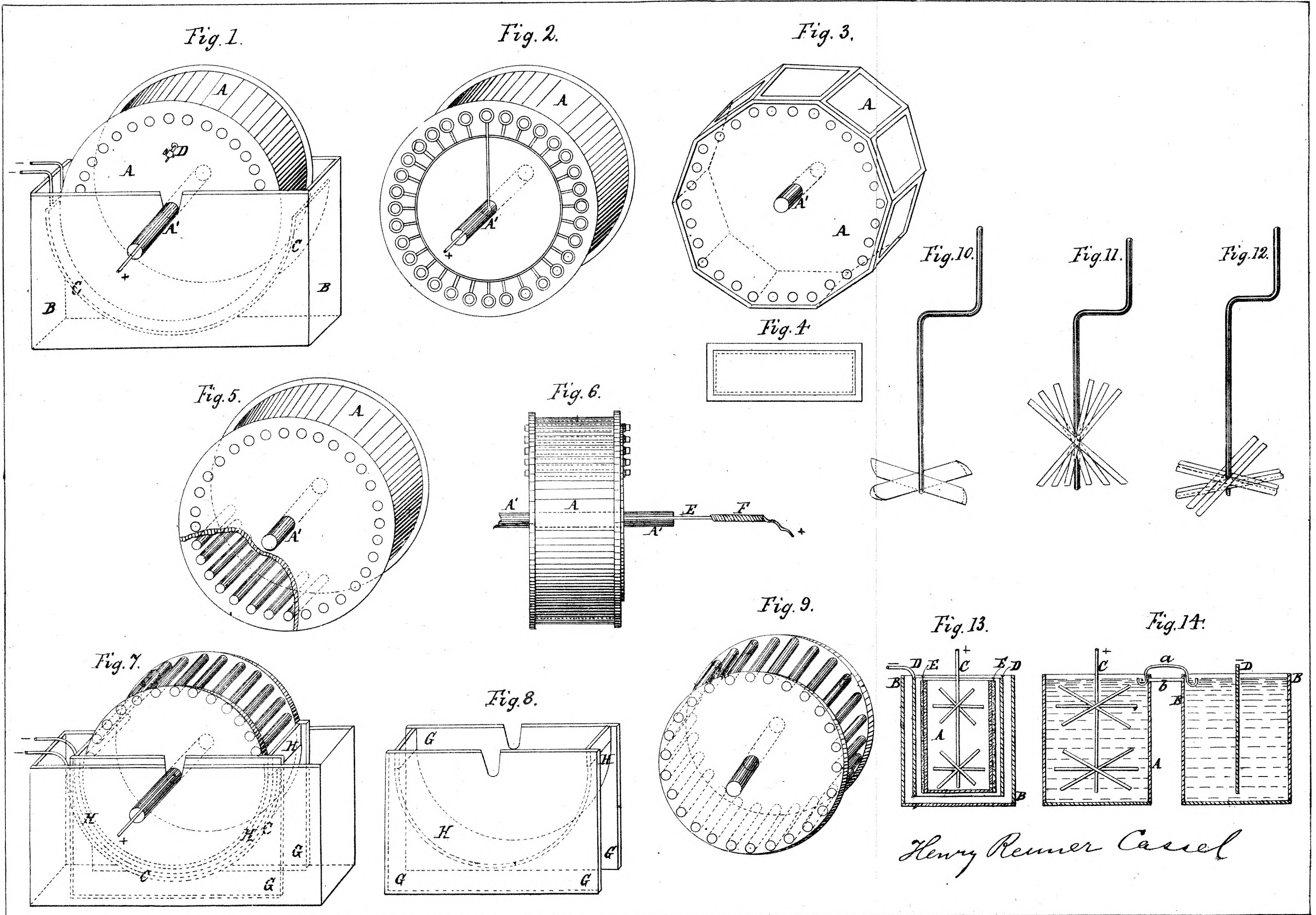
We have, &c.,

J. SMITH.

A. LEIBIUS.

The Under Secretary of Justice.

[Drawings—one sheet.]



Henry Renner Cassel

(Sig: 245)

This is the Sheet of Drawings referred to in the annexed Letters of Registration, granted to Henry Renner Cassel, the twenty-ninth day of August, A. D., 1884. Augustus Loftus.

PHOTO-LITHOGRAPHED AT THE GOVT. PRINTING OFFICE, SYDNEY, NEW SOUTH WALES.



A.D. 1884, 6th September. No. 1492.

IMPROVEMENTS IN THE CONSTRUCTION OF TRAMWAYS.

LETTERS OF REGISTRATION to William Plenderleith Hope, for Improvements in and relating to the construction of Tramways, and in apparatus for facilitating the hauling of Vehicles thereon by means of cables or ropes.

[Registered on the 6th day of September, 1884, in pursuance of the Act 16 Vic. No. 24.]

BY HIS EXCELLENCY THE RIGHT HONORABLE SIR AUGUSTUS WILLIAM FREDERICK SPENCER LOFTUS (commonly called LORD AUGUSTUS LOFTUS), Knight Grand Cross of the Most Honorable Order of the Bath, a Member of Her Majesty's Most Honorable Privy Council, Governor and Commander-in-Chief of the Colony of New South Wales and its Dependencies.

TO ALL TO WHOM THESE PRESENTS SHALL COME, greeting :

WHEREAS WILLIAM PLENDERLEITH HOPE, of Edinboro' and Leith, in the county of Midlothian, North Britain, hath by his Petition humbly represented to me that he is the author or designer of a certain invention or improvement in manufactures, that is to say, of an invention entitled "Improvements in and relating to the construction of Tramways, and in apparatus for facilitating the hauling of vehicles thereon by means of cables or ropes," which is more particularly described in the specification marked A, and the two sheets of drawings marked B and C respectively, which are hereunto annexed; and that he, the said Petitioner, hath deposited with the Honorable the Treasurer of the said Colony of New South Wales the sum of Twenty Pounds sterling, for defraying the expense of granting these Letters of Registration, as required by the Act of Council, sixteenth Victoria, number twenty-four; and hath humbly prayed that I would be pleased to grant Letters of Registration, whereby the exclusive enjoyment and advantage of the said invention or improvement might be secured to him for a period of fourteen years: And I, being willing to give encouragement to all inventions and improvements in the arts or manufactures which may be for the public good, and having received a report favourable to the prayer of the said Petition, from competent persons appointed by me to examine and consider the matters stated therein and to report thereon for my information, am pleased, with the advice of the Executive Council, and in exercise of the power and authority given to me by the said Act of Council, to grant, and do by these Letters of Registration grant unto the said William Plenderleith Hope, his executors, administrators, and assigns, the exclusive enjoyment and advantage of the said invention or improvement, for and during the term of fourteen years from the date hereof; to have, hold, and exercise unto the said William Plenderleith Hope, his executors, administrators, and assigns, the exclusive enjoyment and advantage thereof, for and during and unto the full end and term of fourteen years from the date of these presents next and immediately ensuing, and fully to be complete and ended: Provided always, that if the said William Plenderleith Hope shall not, within three days after the granting of these Letters of Registration, register the same in the proper office in the Supreme Court, at Sydney, in the said Colony of New South Wales, then these Letters of Registration, and all advantages whatsoever hereby granted, shall cease and become void.

In witness whereof, I have hereunto set my sign manual, and have caused the present Letters of Registration to be sealed with the seal of the said Colony of New South Wales, at Government House, Sydney, in New South Wales, this sixth day of September, in the year of our Lord one thousand eight hundred and eighty-four.

[L.S.]

AUGUSTUS LOFTUS.

Improvements in the construction of Tramways.

A.

SPECIFICATION of WILLIAM PLENDERLEITH HOPE, of Edinboro' and Leith, in the county of Midlothian, North Britain, for an invention entitled "Improvements in and relating to the construction of Tramways, and in apparatus for facilitating the hauling of Vehicles thereon by means of cables or ropes."

My invention relates partly to the construction of tramways of that class in which a rope or cable is arranged within an underground tube, and is caused to travel therein by any suitable motor. It also relates to apparatus for facilitating the hauling of vehicles by means of the said rope or cable.

One part of my said invention relates to the construction of a device or apparatus usually termed the "grip" or "gripe," whereby the car may be connected to or disconnected from the moving wire rope in the underground tube.

This part of my invention is illustrated in figures 1 to 5 of the accompanying drawings, in which—

Figure 1 is an elevation, partly in section, of one side of the said apparatus.

Figure 2 is a section on the line xx , figure 1, the upper parts of the levers being shown in elevation.

Figure 3 is an elevation, partly in section, of the other side of the said apparatus.

Figure 4 is a section on the line x^1x^1 , figure 1.

Figure 5 is a section on the line x^2x^2 , figure 3.

The remaining figures are hereinafter described.

Figures 1 to 5 illustrate the parts which constitute the gripe proper. The application of this apparatus and its relation to the car and the moving wire rope will be readily understood by those acquainted with apparatus of this kind. I have shown, however, in the drawings, the wire rope A and a portion B of the car floor; and the dotted line C indicates the level of the slot in the rope-carrying tube, and also the level of the street pavement.

DD' are two standards, formed of short columns, projecting upwards from the centre of long flat bars dd^1 . These standards are held down by the stirrups or straps EE', which are firmly bolted to the floor of the car, and which fit over the bars dd^1 so as to allow the standards to be adjusted sideways by sliding the said bars dd^1 , through the stirrups.

F is a stout iron cross-bar, having bosses ff^1 on each end. These bosses are perforated with holes to fit the columns of the standards DD'. The pins $d''d''$, passing through the columns above the bosses hold the bar down, the said bar being supported upon these standards, and being adjusted as to its horizontal alignments by moving the said standards independently of each other. This cross-bar supports the mechanism for operating the gripe; the position of the whole apparatus can therefore be changed relatively to the centre line of the car, so that if, from any cause, the track and the slot in the rope channel vary from their true parallel relation to each other, an immediate accommodation to the variation will take place, and no damage will occur. In the centre of the said cross-bar there is a vertical slot, to permit the passage through it of the sides GG' of the gripe frame and the operating bar H. The said cross-bar forms a guide for the sides of the gripe frame and the operating bar in their movements up and down. Its guiding surface is, however, too limited; I therefore supplement it by adding the guides IT, which may be attached to the cross-bar in any suitable manner.

By referring to figure 2 the manner in which the rope is griped will be readily understood.

J is a stationary shoe or jaw as long as the entire width across the frame. It is made of wood, steel, case-hardened iron, or other suitable material, and fits against the sides GG' of the frame, being secured thereto by means of small spurs j projecting from the back of the shoe through holes in the sides GG' and small pins j^1 passed through the spurs, where they project through the holes, as shown in figure 3'. The face of this shoe is made concave, to fit half around the rope, or nearly so. The opposing jaw K is movable, and has a shoe or wearing plate k resting in a recess made to receive it, there being no necessity to provide means for fastening this shoe in place, as it has no tendency to become dislodged. The jaw K is vibrated on the fulcrum pins LL', which project from each of its ends and enter holes made to receive them in the bracket pieces MM', which support the carrying pulleys NN'. The brackets are simple L-shaped pieces projecting forward from the outer edge at the bottom of each side-piece GG'. They may be integral with the side-pieces or they may be bolted thereto, as the facilities for manufacturing may dictate.

The rope A is shown passing between the two jaws J and K. Now, when these jaws are spread apart a distance greater than the diameter of the rope, the rope will travel freely between them, but when the jaws are closed upon the intervening rope the latter will be tightly pinched, and, instead of travelling through, will carry with it the gripe and the attached car. To open and close these gripping jaws, or rather to operate the jaw K to open from and close against the jaw J, I extend a tail-piece K' from the middle of the length of the jaw K to constitute a lever or handle, and enable the rope to be gripped with considerable force. This tail-piece is the width of the operating bar H, to the lower end of which it is secured by three links O, so that when the operating bar H is moved up or down the motion will be transmitted to open and close the gripe. When these links are so related to the tail of the jaw K and the bar H as to approach a horizontal position, it will be seen that their combination will involve the principle of that powerful device known as the "toggle-joint." In figure 2 the links stand rather nearer a vertical position than is intended in practice. In figure 1' the position is about correct. The operating bar H extends upward between the sides GG' and terminates in a frame H' surrounding the cam or eccentric P. This bar is guided and held from having side motion by the check pieces or plates QQ' and the bars RR' which are riveted to the bar H and overlaps the sides GG'. The cam P is secured firmly upon the pin or axle S, upon which axle is also secured the hand lever T, so that when this lever is swung back or forth the cam is moved to elevate or depress the bar H, and the gripping jaws are thus opened or closed. The two checks or plates QQ' and the sides of the frame GG' are bolted firmly together by the six bolts ee , and a brace piece U, at the bottom, is provided, to stiffen the brackets MM'. The carrying pulleys NN' are supported by having their axles set in holes made to receive them, on one side in the brackets MM', and on the other side in the plate VV', which are fastened to the frame GG' by the bolts or rivets vv^1 .

The plate Q' has formed upon its upper edge the ordinary ratchet toothed quadrant, and the hand lever T has double-acting pawls tt^1 , which are pressed into the notches of the quadrant by springs t^1t^1 and are lifted out when pressure is exerted upon the lever t^1 and the bar t^{11} is pressed down upon the pawls so

Improvements in the construction of Tramways.

as to tip them over. There is nothing new, however, in the construction or operation of this pawl and ratchet contrivance, and I need but refer to the drawings as amply descriptive.

It is sometimes necessary to disconnect the gripe from the wire rope for a length of time beyond the usual few seconds required to take up and let down passengers upon the road, as, for instance, when the track is obstructed for half an hour or more. On these occasions it is desirable to avoid the running of the small carrying pulleys NN¹ by the moving rope supported by them. I therefore arrange to drop the gripe and all its parts until it is entirely free from contact therewith, and the rope descends so as to rest upon the main carrying pulleys hereinafter referred to. This result is accomplished by actuating the lever W, which oscillates on the fulcrum pin *w* integral with or fastened to the plate Q. On the lower end of this lever there is a roller or anti-friction wheel X which rolls along the ledge Y when the lever is depressed. The ledge Y is formed by bolting a piece of angle iron to the back of the cross-bar F, and the guard-rail Z is applied to give security against the gripe rising by reason of jolting on the rack or other causes. It also limits the throw of the lever, and, consequently, the distance the whole gripe may be allowed to drop, by confining the travel of the roller X within the space enclosed by the guard-rail Z. As the whole gripe is supported or held up by the lower part of the lever W interposing between the ledge Y and the pin *w*, it will be readily seen that if this lever be canted over so as to bring the pin *w* nearer to the ledge the effect will be to depress the gripe, and when the lever is brought to its perpendicular position the gripe will have attained its greatest elevation, which is the position it is required to occupy when engaging with the rope. To give firmness and stability to the gripe in this latter position I provide a small hollow place, in which the roller may rest, in the middle of the ledge.

In figure 4 I have shown the spiral springs *nn*¹ interposed between the hubs of the carrying wheels NN and the plates VV¹. This arrangement is intended to allow the wheels a little side play, though in practice it may be found unnecessary.

It will be seen from the foregoing description that the guide may be operated with a pull or a push indiscriminately, and whether the operator be facing one end of the car or the other, and it will also be observed that three systems of leverage are introduced:—First, that resulting from the difference between the distance from the fulcrum centre to the points of connection of the links with the tail-piece K¹, and the distance from the same centre to where the jaws bear on the rope; second, the toggle-joint principle, which may be introduced at the place where the links are; third, the leverage obtained from the difference between the throw of the cam P and that of the lever T. From these compound leverages it will be readily understood that the operator will have little difficulty in firmly gripping the rope.

According to another part of my said invention I place the gripe or gripe upon a frame carried by and between the axles of a passenger car, and arrange the said gripe to be operated by any suitable mechanism from either end of the car, or by such a device as is herein described, the object being to avoid the use of a separate car or "dummy" to carry the gripe, and, at the same time, to avoid obstructing the car by gripe-operating mechanism.

This part of my said invention is illustrated in figures 6 to 9 of the accompanying drawings.

Figure 6 is a plan showing the mechanism arranged below the line of the floor of the car, the central part of the said floor being broken away to show the parts more clearly.

Figure 7 is a side view, the rear wheels of the car being removed.

Figures 8 and 9 are views, drawn to an enlarged scale, illustrating details as indicated by the reference letters.

A is the floor of an ordinary tram-car, B the front platform, and B¹ the rear platform thereof, CC are the wheels of the car, and DD the axles, E is a stout iron hanger which is supported by the axles D. This hanger is composed of the two bars *e* and the two sleeves *e*¹ to which the bars are fastened. The sleeves fit upon the axle D, and are held from lateral movement by reason of the axles being turned down to a smaller diameter where the sleeves are situated, so as to form a shoulder at each end of each sleeve; collars and set screws may, however, be used at each end of the sleeves, for the same purpose. The sleeves are made in halves, which are bolted together, as shown in figures 6 and 7.

The bars *e* are depressed in the middle, as shown in figure 7, to afford space for the working parts carried thereby. Upon these bars I provide four caps or stirrups F, which are firmly bolted to the said bars, and form guides and bearings in and through which the cross-bars G pass, so that these cross-bars will be firmly held down whilst each can move endwise independently of the other. Upon these cross-bars the gripe is secured, their use being to provide adjustability for the gripe, both as to its height in relation to the rope H, and its position relative to the slot in the road-bed.

These said cross-bars have the standards QQ standing vertically in about the middle of each bar to receive the gripe I, that is to say, the said standards are passed through holes in the hubs formed on each end of the tie-frame *i* of the gripe.

There is placed upon the shaft or axle of the cam or eccentric a gear-wheel J. This wheel is moved to the right or left in operating the gripe by a rack K, which slides to and fro in a suitable guide or bearing L, bolted to the stationary side bars of the gripe. The rack K is connected at each end to two other racks M supported in suitable guides or bearings N, fastened under the extreme ends of the platforms BB¹. The connections are made by the rods O; in making the joint between the rods O and the said racks, the fact must be observed that one rack is attached to the car body, which, being supported on springs, varies its position as regards height from the ground according to the load it carries, this variation often exceeding two or three inches, whilst the other rack is attached to the gripe, which is adjustable both as to its height and horizontal position. For this reason it is preferable to provide for some flexibility in these joints, though the spring of the rods, when they are long enough, will often answer the purpose. It may be preferred in some cases to support these rods in guides fastened on the car bottom. In such cases an intermediate flexible link in the rod may be provided at the gripe end. The racks M engage with toothed pinions P loosely fitted on the lower ends of the upright rods Q¹. RR are hand wheels secured to the upper ends of the rods Q¹ whereby the said rods are turned. SS are ordinary ratchet-wheels which, together with the pawls T, serve to prevent the rods Q¹ from turning backwards when the operator releases his hold of either of the hand-wheels. UU are discs loosely fitted on the rods Q¹, and either cast solid with, or suitably

Improvements in the construction of Tramways.

suitably fastened to the pinions P. These discs are perforated with six or eight holes at such a distance from the centre as will correspond with a hole formed in each of the ratchet-wheels S. V is a pin which, when passed through the hole in one of the ratchet wheels and into one of the holes in the disc U immediately below, serve to lock these two parts together so that when the upright shaft is turned by the hand-wheel the pinion, though loose on the shaft, is revolved with it.

When this pin is removed, the pinion cannot be rotated by turning the hand-wheel. There being but one pin, which the driver carries with him from one end of the car to the other, no one can operate the other end in his absence,—a matter of necessary precaution to avoid accidents.

The upright shafts are supported on frames W, which project from underneath the car platform, a suitable metal step being provided to receive the point of each shaft. Bearings for the shafts are also attached to the rails of the platform, as for ordinary brake-wheel shafts. The brake for the car is similar to those ordinarily used.

Immediately over the gripe there is provided in the floor of the car a trap-door, sufficiently large to pass a gripe through. Generally the gripe is put in place whenever the car goes into service and removed when it returns from service, and sometimes it is required to be taken up or examined in the middle of a trip.

In this class of tramways to which this invention relates the engineer or driver must always have an unobstructed view of the track in front of him. This necessitates his occupying the front platform, which is at one end of the car or the other, according to whether the car is going out or returning on its trip, in cases where the car is not turned round at the termini. He, therefore, requires a set of mechanism at each end in such cases, but if the arrangement of the road permits the car to be turned end for end at the termini, then only one set of operating rods and gearing need be supplied.

The operation of the apparatus shown in figures 6 to 9 is as follows, that is to say:—The car being ready to start, the engineer or driver inserts the pin V through the ratchet-wheel and disc; he then turns the hand-wheel so as to cause the pinion P to act on the rack M and draw the rod O towards it; motion is thus transmitted to the gear-wheel J on the cam shaft of the gripe, so as to raise the bar which in this gripe operates to close the jaws tightly on the rope; a reverse motion releasing the rope from the jaws. In many cases the engineer or driver can act as conductor also, and thus effect economy.

In some cases I provide a treadle-lever in connection with the gripe mechanism, which lever can be operated by the foot of the driver to release the gripe on the cable, so that no turning of the hand-wheel is necessary in stopping; it is only necessary in starting.

Another part of my invention relates to means for automatically disengaging the car from the rope at certain points on the line, as, for instance, where a cross rope line exists; means for checking any retrograde movement of the car when so disengaged; and means for preventing any damage to the rope in case of accidental inoperation of the parts.

This part of my invention is illustrated in figures 10 to 12 of the accompanying drawings.

Figure 10 is a side view of the automatic disengaging device, or trip, with automatic stop-lever or latch.

Figure 11 is a plan of the part which require to be thus shown.

Figure 12 is a sectional view, drawn to an enlarged scale, of a portion of a gripe, illustrating the application of a safety spring behind the shoe or wearing plate of the jaw-gripe. A is the floor of a car, BB are the wheels, and CC the axles thereof, and D is the gripe. This gripe is supported on the frame E, which rests on the axles, F is the rope, G is the channel iron, which also represents in figure 10 the line on the surface of the road bed. H is a pulley, set above the ordinary rope-carrying pulleys of the road, so that when the gripe-jaws are opened the rope will be lifted out from between them. The gripe is operated as follows, that is to say:—By turning the hand-wheel I, the shaft J and the pinion K are rotated. This pinion K engages with the rack L, connected by the rod M to the rack N. This rack, in turn, engages with the gearing-wheel O upon the spindle P. On this spindle the eccentric Q is secured, which eccentric moving within the frame R raises and lowers the bar S to open and close the gripe-jaws T. Upon the shaft J there is a ratchet-wheel U with a spring pawl V, a spring *v* being fitted between a projecting arm on the spindle *v*' of the pawl and the shaft J or other convenient part. A spiral spring W is connected, as hereinafter described to the end of the rack N, one end of which spring is secured to the frame E.

X is a lever hinged or pivoted to the frame E, and extending to within an inch or so of the surface of the channel iron G. This lever is connected by the rod Y with a horizontal arm of the pawl spindle *v*' in such a manner that when the hanging-lever is swung back by coming in contact with the block Z (which is permanently set in the road bed) as the car advances, the pawl spindle will be turned sufficiently to throw the pawl out of engagement with the ratchet-wheel. Immediately this operation takes place the spring W acts, to draw back the rack N, and the gripe-jaws are opened and the rope released. At the same time the gong *a* is struck, which gong is connected by a cord *b* to the lever X. The block Z is long enough to ensure the lever X being kept back a sufficient length of time to give an opportunity for the device to act.

A hook *c* with a tail piece forming a handle, as shown in figure 10, connects the rack N with the spiral spring W. This arrangement is for the sake of convenience in hooking and unhooking this spring in removing and replacing the gripe.

d is a swinging latch to stop any backward motion of the car when the gripe is opened and the car is proceeding up a grade. This latch is pivoted under or upon the channel iron. It has a hooked rear end with a bevelled point, and a forward end bent at an angle, as shown in figure 11. As the gripe shank passes through or along the slot it strikes the rear end of the latch, pushes it aside, and moves the forward end across the path of the gripe. The gripe still advancing strikes the forward end, pushes it to one side, and returns the hooked end into the path of the gripe, so as to block its way if a retrograde movement should occur. This latch may be rigidly secured by a couple of rivets, and the natural spring of the lever between the fastening and the hooked point may be relied upon to return the hook to the path of the gripe after it has been pushed aside. In this case the lever should be long enough to afford the requisite elasticity, and the forward part may be dispensed with.

Improvements in the construction of Tramways.

In figure 12 I have shown a piece of India-rubber *c* placed behind the wearing plate or shoe of the gripe-jaw. This elastic piece is provided in case the latch *d* should be so misplaced as to block the progress of the car before the gripe-jaws were opened. Its effect is to allow the rope to be pulled through the jaws instead of being broken or stranded, the India-rubber yielding sufficiently for this purpose, although ordinarily it will hold sufficiently to enable the car to be drawn by the rope. This India-rubber backing for the gripe-jaws is also used to prevent the shock which occurs when a quick motion is given to the gripe-jaws in re-closing them after the obstruction is passed. This said elastic piece or spring may be placed behind either or both dies.

The dotted line *x* shows the ordinary level of the rope when not required to be lifted out from between the gripe-jaws. The block *Z* can, if desired, be arranged under the channel iron instead of upon it, the parts being modified to suit; and the lever *X* can, if desired, be fitted with a small friction roller at its lower end, to roll over the block *Z* instead of scraping over it.

According to a modification of this part of my said invention a swinging arm is pivoted at any convenient part of the car, preferably just behind the gripe, and suspended from its carrying-frame; this arm has a cam-shaped upper end, and its lower end may enter the slot of the underground tube. The cam operates upon an intermediate plate, transmitting motion directly to the pawl which locks the gripe; the toothed rack of the gripe is caused to be drawn back (when the gripe is not locked) by a stout spring, suitably arranged. A tripping plate is placed on or under the slot or channel irons of the tube at the point desired. When the lower end of the lever meets this obstruction it is drawn back and the cam end lifts the intermediate plate, the pawl is thrown out of engagement with its rack, the gripe is unlocked, and the spring then coming into action opens the gripe, and the car stops.

This automatic tripping device is made to sound a bell or gong, to notify to the driver or engineer every time it operates; it may be used for the purpose of giving a gong alarm at crossings without reference to the opening of the gripe, by simply attaching a cord to the swinging lever of the tripping device in such a manner that the gong will be sounded when the lever is pulled back.

Another part of my invention relates to improved means for cleaning the bottom of the underground tube. According to this part of my invention a drag, scraper, or brush, is so arranged as to be drawn with the car and follow the sinuosities of the tube, and be also capable of being raised or lowered, to put it in or out of service at will. It is attached to the gripe or any convenient part, and may be used as often as necessary. The gripe as it travels drags the said scraper along the bottom of the channel, and at proper intervals are arranged "sumps" into which the material thus gathered drops, to be emptied out when convenient. The aforesaid releasing devices act on this scraper whenever they act on the gripe, so that when the gripe is released the scraper is raised to pass over any obstruction.

Another part of my invention relates to the means for guiding the wire rope or cable around a curve or sharp angle, so as not to interfere with the free passage of the gripping device past the guides.

In carrying this part of my said invention into practice I provide one or more pairs of guides and compensating pulleys, revolving on axles fixed on the ends of bars which swivel upon fixed pivots passing through their centres. These pulleys, by their combination with proper carrying-pulleys and shoes upon the gripe, yield automatically as the gripping device makes contact with them consecutively, while in pairs they firmly and unyieldingly support the rope at equi-distant points in the curve.

There are two occasions upon which curves occur in tramways:—First, when the line diverges on the horizontal plane, as when the line passes through streets running at an angle to each other; secondly, when the line diverges on the vertical plane, as when sudden changes of grade occur. The principle and effect of my device, as I apply it on both these occasions are the same, but the pulleys are set to revolve in the one case horizontally, and in the other case vertically.

This part of my invention is illustrated in figures 13 to 17 of the accompanying drawings.

Figure 13 is a sectional plan of an underground ropeway, in which four pairs of my swivelling pulley guides are shown guiding the rope around a horizontal curve.

Figure 14 is a plan of the same, showing removable covers, permitting access to the pulleys for oiling or other purposes.

Figure 15 shows a sectional elevation of a ropeway with a sharp change in the grade and one pair of my pulleys placed at the intersection of the two grades, exemplifying a vertical curve.

Figures 16 and 17 are front and end views of a detached detail, showing how the bevel-ended shoe *M* is applied to the bottom and to the sides of a gripe to operate the pulleys both on vertical and horizontal curves.

In order that the object of this device may be more readily understood, I will first describe the difficulties at present experienced with rope-tramways of the class herein referred to.

Ordinarily the wire-rope is placed below the ground in a tube or channel way. This tube has a slot through which the shank of the gripe passes, the said shank being connected with the "dummy" which drags the car behind it. Now, when the jaws of the gripe pass along the tube they must, necessarily, avoid contact with all rigidly-set carrying wheels, or damage would occur; hence it has been the practice to place the carrying wheels entirely below the plane through which the gripe-jaws move, and the "depression pulleys," so called, used at the intersection of varying grades, as in figure 15, entirely above the same plane, so that under no circumstances can contact occur between gripe-jaws and pulleys. The depression pulleys at the intersection of an up grade with level ground cannot project above the road-bed, so the conditions imposed have heretofore necessitated the use of pulleys of very small diameter, their size being limited to less than the space between the top of the gripe-jaws and the under side of the covering plate in the road-bed. Seldom are these pulleys over six inches in diameter. Now, when it is immaterial whether the gripe-jaws strike the depression pulleys or not, when these pulleys may encroach upon the path in which the gripe-jaws move, they being arranged to be gently pushed aside without shock as the gripe passes, then they may be increased in size, and great advantages in their operation accrues.

Again, some gripping devices have jaws opening horizontally in such a manner as to allow the rope to be drawn upward entirely out of the gripping jaws when the strain on the rope has a direction causing it to incline upward from the line of travel of the gripe. As, for instance, suppose the rope suddenly ascends a steep

Improvements in the construction of Tramways.

steep grade, and the "dummy" with the gripe attached is still upon level ground; on such occasions the strain on the rope will tend to draw it out from between the jaws, if these jaws open horizontally. Now, if these jaws be opened at such a place in the road, the rope will fly out and cannot be returned between the jaws, unless the "dummy" with the attached gripe is backed on the road until that part of the rope is reached which is sufficiently sagged down to be inserted between the jaws again. This inconvenience is not experienced with some gripes, where one of the jaws is above the rope, always holding it from flying upwards.

Again, where the old style rigid depression pulleys are used at intersecting grades, which pulleys must be set above the line of travel of the gripe-jaws, there has been found to be great wear both of the rope and the upper jaw, by reason of the rope running through the jaws when the car temporarily stops at the point of intersection, and also by reason of the upward strain of the rope, due to the angle the rope forms with the line of travel of the gripe. I avoid this inconvenience with my device, for I do not set the depression pulleys above the line of travel of the gripe, but preferably a little below it, or at least low enough to keep the rope always travelling upon a line coincident with the line of travel of the gripe.

Moreover, heretofore in turning horizontal curves there has been no means of guiding the rope, which did not necessitate its release from the gripe, and, therefore, the car had to be run around the curve by other power than that which the rope furnished, and if the car happened to be stopped upon or near the curve difficulty was experienced in moving it again without unloading it of its passengers. Now, with my device the car will pass around such curves with perfect ease, retaining the rope in the gripe, and may stop and go ahead at any part of the curve without difficulty.

In figures 13 to 17 A is the wire rope, B is the channel-way, C is the slot through which the shank of the gripe D passes to connect with the "dummy" E, which "dummy" drags the car F behind it. GG¹ are my guide-pulleys, H is the swivelling-bar or lever upon each end of which one of these pulleys is placed. The said pulleys revolve on pins II¹. J is the pin or axle which carries the swivelling bar, K is the bracket piece which carries the pin J. This bracket piece is made fast to timbers set in the road bed or to the cover L, according to circumstances. In figure 13 I show the last pair of pulleys in the set just at the moment when the gripe is passing.

It will be necessary to provide upon all gripes operating on roads where my device is employed a wedge-shaped guard, as at M, figures 13 and 15, or the jaws of the gripe when used to put aside the pulleys should have tapered ends, so that there will be no shock on striking. A piece of India-rubber or other elastic material may be used to reduce the shock if it is found necessary in practice.

It will be observed in figure 13 that the shank *m* of the gripe is offset from the jaws, so that it may freely pass the depression pulleys, as in figure 15. Nearly all gripes are so constructed.

NN are the carrying-wheels for supporting the rope, which wheels are set a suitable distance from the first and last of the guide-wheels GG¹. The gripe has to pass over these carrying-wheels N, and ordinarily they may be set several feet away from the guide-wheels and below the path of the gripe; but in some cases it may be found necessary to bring these carriers N close to the guide-wheels, and to allow them to enter the path of the gripe, so as to hold the rope at a proper height. When this is done they must be so arranged that the gripe as it passes shall slightly depress them out of its path. I do not think, however, that any carriers except the ordinary ones are necessary. Much will depend on the conditions under which the invention is applied.

Any suitable description of depression pulleys may be employed. I may here mention that in a horizontal curve I can easily double the number of guide-pulleys in the same space by placing one swivelling bar over another, making the end pulleys of all the bars to stand intermediate with the two pulleys of the opposing bar, but as I do not think this arrangement will be necessary, I will not further elaborate my description thereof, for any one conversant with the subject will easily understand the construction.

According to a modification of this part of my invention I construct the swinging bars or levers as hereinafter set forth, and combine them with the pulleys and with each other in sets or series, by which combination certain advantages of operation are obtained, as hereinafter set forth.

This modification is shown in figures 18 to 22 of the accompanying drawings.

Figure 18 is a plan showing a rope guided around a curve by my improved guiding pulleys.

Figure 19 is an edge view of one section of a set of pulleys resting upon the bars.

Figure 20 is a similar edge view in which the pulleys are shown hanging below the bars.

Figure 21 is a plan drawn to an enlarged scale, and one of the bars slightly differing in form from those shown in the previous figures, and

Figure 22 is an edge view of the same.

In figure 18 A is the rope upon which at B a gripping device of any suitable kind is attached.

The gripe is provided with a bevel-ended shoe or plate C in a convenient position so that this shoe will make contact with the guide-pulleys instead of the gripe itself, and with a gradual easy approach, so that there may be no sudden shock. DD are the guide-pulleys which carry the rope upon an approximately curved line. They revolve upon vertical pins EE, projecting either upwards, as in figures 18 and 19, or downwards, as in figure 20, from one end of each of the swinging bars FF. These swinging bars oscillate on the fulcrum pins GG. Each bar F, as in figure 18, projects at that end opposite the one on which its guide-pulley is secured, behind the pin E, carrying the next guide wheel on the succeeding bar, if there be one, in such a manner that when the guide-pulley on one end of a bar is pressed back the other end of the bar to which it is attached will push forward the guide-pulley secured to the succeeding bar; and again, if there be a preceding bar and pulley, a similar effect will be produced thereon. As at each end of the curve there is a first bar or last bar, there can be no double action by these end bars. The result of the combined action of these swinging bars is such that the wheels always hold the rope perfectly straight and in line with the gripe-jaws between supports or guides, that is to say, the rope will not be bent at an angle immediately before and after passing through the gripe-jaws; this forms an important feature of the said invention, as it is very injurious to wire ropes used in this class of tramway to cause them to continually pass sharp angles or bends.

By

Improvements in the construction of Tramways.

By my system there is also the further advantage of avoiding side or torsional strain upon the gripe, and consequent friction of the gripe shank against the side of the slot when my improvement is applied in underground tubes, because the rope being held at all times parallel with a chord of the arc through which the gripe is travelling the strain is necessarily directed within the line of travel, or nearly so, as the succession of short chords approaches the true curve. If it were otherwise, and the rope were permitted to pull at various angles to the actual line of travel, it will be readily understood that the passage of the gripe around the curve would be attended with a great amount of friction between the shank and the side of the slot in those cases where the gripe moves in an underground slotted tube.

I also find that, with my plan of combining the swinging bars, the rope is not subjected to any extra strain as the gripe passes the guide-pulleys, the action being such that, as nearly as may be, a compensation occurs as the pulleys swing in or out, which renders the same length of rope sufficient to encompass the curve, whether the gripe be passing through or not.

I have shown in figures 21 and 22 a plan and edge view of a swinging bar which is slightly different from that shown in figure 18, inasmuch as it has a slotted end at H to receive the pin E of the adjacent bar, so that all the swinging bars may be more securely connected.

According to a further modification of this part of my invention I apply a long bevel-ended shoe or shoes to each of the swinging levers above described, with which shoe the gripe makes contact, displacing the guide-pulleys as it passes through the curve, thus avoiding the shock which occurs when the gripe comes in sudden direct contact with the guiding pulleys.

This modification is shown in figures 23 to 25 of the accompanying drawings.

Figure 23 represents a plan of a set of guide-pulleys and swinging levers with my improvement applied thereto.

Figure 24 is an edge view of the same with the gripe shown in position.

Figure 25 illustrates the application of my improvement in cases where the guide-pulleys are used as depression pulleys at vertical curves, for instance, where the road suddenly changes from a level to an up grade.

In these figures AA are the rope-guiding pulleys; BB the swinging levers to the ends of which the pulleys A are attached; CC are the fulcrum pins for the levers B, which pins project from metal plates, resting on any suitable foundation in the road-bed; D is the gripping device, which may be of any suitable form; EE are my improved bevel-ended shoes.

These shoes are made of either iron or wood, and ordinarily are secured by bolts *d* to the levers B. It may be desirable, however, in some cases to make the shoe and lever in one piece. The ends of the shoes are bevelled, as shown, and extend beyond the guide-pulleys, a distance equal to half the distance between the guide-pulleys; the taper or bevel given to each end of the shoe will represent half the width of the gripping device, because half the width of the gripe represents the distance the guide-pulleys are set back when the gripe passes through the curve.

The gripe itself may be provided with the bevel-ended shoe, as above described, or, in lieu thereof, a couple of wheels or rollers *e* may be fastened beneath the gripe and placed in such a position as to roll along the edge of the shoe in the act of pushing aside the guide-pulleys.

As the wheels or rollers *e* constantly maintain contact with one or other of the shoes as the gripe passes through the curve, and as more or less pressure is thereby brought to bear upon the gripe, tending to push it over to the other side from the guide-pulleys, a compensation of strain occurs which has the effect of maintaining the gripe in about the true line of the curve, independently of its being held there by the shank of the gripe passing through the slot in the road-bed. This peculiar action has the effect of greatly relieving the friction of the gripe shank upon the inner edge of the slot.

When the gripe is in the centre between a pair of guide pulleys, it is maintained at exactly the centre of the slot in the road-bed, when the rollers *e* touch the shoe, and there is no side strain; there is, however, a slight side strain as the gripe passes by the ends of the shoes.

Another part of my invention relates to the tube in which the rope travels. I make this tube A (figures 26 and 27) of cast-iron, of U-shaped transverse section, as shown in the said figures, of which figure 26 is a transverse section; and figure 27 is a section on the line *x²x²*, figure 26. The said tube is made in lengths or sections, each about 12 feet long, the flanges B, where the sections abut, forming stiffening ribs. In this tube the carrying-wheels are so arranged that they extend only about five inches above the bottom of the tube, the remainder of the said wheels being enclosed in a box or pit D below. This arrangement permits the employment of a tube of less depth than usual, and of large carrying wheels, independently of the depth of the tube.

Where the wheels project above the bottom of the tube there is a guard-rim E cast about the opening (say about four inches high), which rim prevents water, dust, or dirt from falling into the wheel pit. Where these wheels project into the tube there must be no obstruction to the flow of water, and as it is always desirable to maintain a free passage equal to the full cross-sectional area of the tube, I provide an enlargement of the tube, forming a deflection of the channel at the points where the wheels are situated.

The angle irons or rails F, which form the slot in which the gripe shank travels, rest on the upper edge of the cast-iron sections A. The said rails may be shaped like ordinary tramway rails, and old tramway rails placed on edge will answer very well. At proper intervals peculiarly-shaped wrought iron braces GG', which are bolted both to the rails forming the slot and to lugs or flanges on the cast-iron tube A, extend out transversely, and are bolted to brackets or sockets I, to which the rails J are firmly secured. There are other braces G² attached to these brackets, which braces pass under the tube A and have a wide-spread V-shape. The carrying wheels C are at all times easily accessible by removing a man-hole plate H, which covers the box D, cast on the side of, say, every third section.

Having thus fully described the said invention and the manner of performing the same, I wish it understood that I claim—

First—In a gripping device or apparatus for connecting the rope with the car or “dummy” on a rope tramway; the stationary shoe or jaw resting against or attached to any suitable support, in combination with the movable jaw having the tail-piece to act as a lever for operating it, and with the operating mechanism, all substantially as described, with reference to figures 1 to 5 for the purpose specified.

Second—

Improvements in the construction of Tramways.

- Second—In a gripping device or apparatus for connecting the rope with the car or “dummy” on a rope tramway; the combination of the hand lever T secured upon the axle S; the eccentric or cam P, also secured upon the said axle and arranged to be moved by the said hand lever; and the bar H and frame H¹, all substantially as described, with reference to figures 1 to 5, for the purpose specified.
- Third—In a gripping device or apparatus for connecting the rope with the car or “dummy” on a rope tramway; the combination of the cross-bar F with the standards Dd, D¹d¹, held down to the car floor by the stirrups EE¹, but each independently adjustable therein, substantially as described, with reference to figures 1 to 5, for the purpose specified.
- Fourth—In a gripping device or apparatus for connecting the car or “dummy” with the rope of a rope tramway; the lever W pivoted on the pin or fulcrum w and having the anti-friction roller X at its lower end, in combination with the ledge Y, or with the floor of the car or “dummy,” the pin or axle w being so secured to the parts of the gripe that the latter may be raised or lowered thereby, substantially as described, with reference to figures 1 to 5, for the purpose specified.
- Fifth—In a gripping device or apparatus for connecting the car or “dummy” with the rope of a rope tramway; the combination of the sides GG¹ of the frame; the plates QQ¹; the bar H, with the frame H¹; the cam P and the lever T, supported on the axle S; the gripping jaws J and K, with the links O; and the carrying pulleys N, all substantially as described with reference to figures 1 to 5, for the purposes specified.
- Sixth—The combination with a passenger car, of a rope-gripping device arranged underneath the floor of the car and supported by and between the axles or otherwise, and operated from one or both ends of the car by suitable mechanism, substantially as described, with reference to figures 6 to 9, for the purpose specified.
- Seventh—The combination with a passenger tram-car, of the hanger E, the gripe I with the gear-wheel J, the rack K, the rod O, the rack M, the pinion P, and shaft Q¹, all arranged to be operated as described, with reference to figures 6 to 9, for the purposes specified.
- Eighth—The modification of my invention wherein I employ a treadle lever in combination with the gripe mechanism, as above described.
- Ninth—The combination with the gripping device of an automatic device to open the jaws of the gripe at definite points in the line, substantially as described, with reference to figures 10 to 12, for the purpose specified.
- Tenth—The combination of the lever attached to the under portion of the car and the stationary block placed permanently upon the road-bed, the said lever and block being so arranged that the lever will be acted upon by the block, and caused to open a gripping device or sound a gong, or to effect both these operations, substantially as described with reference to figures 10 to 12, for the purposes specified.
- Eleventh—The combination of the lever X, the block Z, the rod Y, and the pawl V, operating together to release the lock upon the ratchet-wheel U and allow the spring W to act upon suitable mechanism to open a gripping device, substantially as described, with reference to figures 10 to 12, for the purpose specified.
- Twelfth—The latch secured at the side of the slot in the road-bed, through which the gripe shank passes, and arranged to be vibrated or oscillated horizontally by the passing gripe shank, to prevent retrograde movement of the car, substantially as described, with reference to figures 10 to 12.
- Thirteenth—In a rope tramway the means substantially as described for cleaning the underground tube.
- Fourteenth—In a rope tramway the set of pulleys GG¹, which pulleys are arranged at equal distances apart, to bear against the side of a horizontal rope, so as to retain the same approximately in a horizontal curved line, and which are capable of being revolved on vertical pins II¹, projecting from levers H, capable of oscillating on stationary pins J, all arranged to operate in combination with the carrying pulleys N and the bevel-ended shoe M attached to the gripe, substantially as described, with reference to figures 13, 14, 16, and 17, for the purpose specified.
- Fifteenth—In a rope tramway, a set of two, or any greater even number of guide-pulleys GG¹, arranged to revolve above the rope upon pins II¹ secured upon opposite ends of the lever or swinging-bar H, and to operate in combination with the bevel-ended shoe M upon the gripe D, substantially as described, with reference to figures 15 to 17, for the purpose specified.
- Sixteenth—The combination of three or more levers or bars capable of oscillation on fulcrum pins, and each having a guide-pulley on one end and engaging with the adjacent bar or bars in such a manner that when the guide-pulley attached to one bar is pushed back by the passing gripe the guide-pulley on the preceding or succeeding bar, or both, will be correspondingly moved forward, so as to maintain the rope in a straight line between alternate pulleys when the gripe is between the same, substantially as described, with reference to figures 18 to 22, for the purpose specified.
- Seventeenth—The modification of my invention wherein I employ the bevel-ended shoes applied to the swinging bars or levers, with which shoes the gripe makes contact, to push aside the guide-pulleys, substantially as described, with reference to figures 23 to 25, for the purpose specified.

Eighteenth—

Improvements in the construction of Tramways.

Eighteenth—In a rope tramway, the employment of large carrying wheels, arranged in a box or pit, formed at the side of the underground tube, so that the said wheels extend only a short distance into the said tube, substantially as described, with reference to figures 26 and 27, for the purpose specified.

Nineteenth—In a rope tramway, the U-shaped underground tube in combination with the braces connecting the same to the brackets or sockets carrying the rails, substantially as described, with reference to figures 26 and 27.

In witness whereof, I, the said William Plenderleith Hope, have hereunto set my hand and seal, this nineteenth day of May, 1884.

WILLIAM P. HOPE.

This is the specification marked A referred to in the annexed Letters of Registration granted to William Plenderleith Hope, the sixth day of September, A.D. 1884.

AUGUSTUS LOFTUS.

REPORT.

Sir,

In reference to your B.C. of the 2nd instant, forwarding a petition from Wm. P. Hope, for Letters of Registration for an invention entitled "Improvements in and relating to the construction of Tramways, and in apparatus for facilitating the hauling of Vehicles thereon by means of cable or ropes," we have the honor to state that, having examined the plans and specification accompanying the petition, we are of opinion that Letters of Registration may be issued to the applicant for the invention in question.

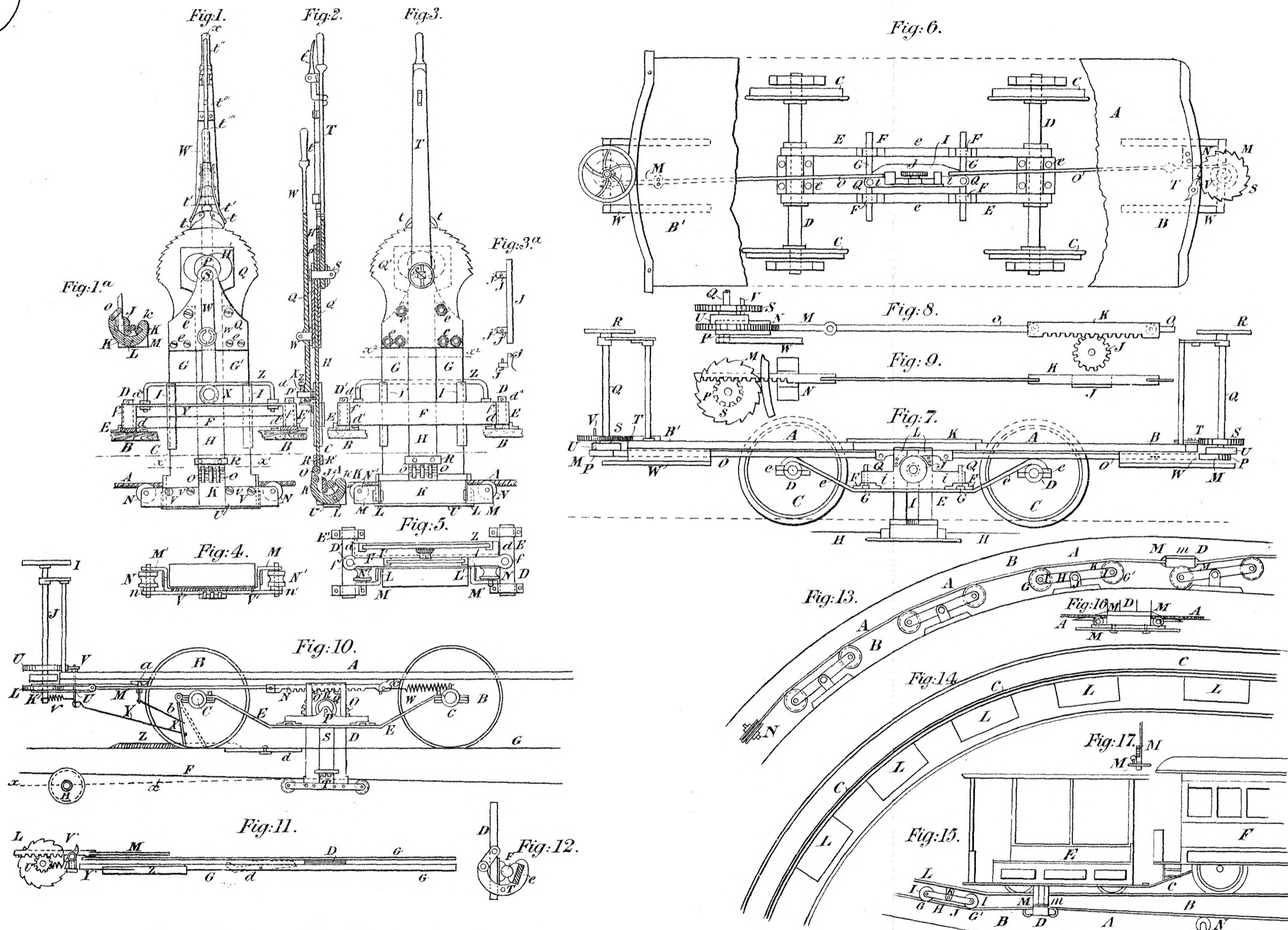
We have, &c.,

JOHN WHITTON.
E. O. MORIARTY.

The Under Secretary of Justice.

[Drawings—two sheets.]

245—6 L



This is the Sheet of Drawings marked B referred to in the annexed Letters of Registration, granted to William Plenderleith Hope, the sixth day of September, A. D., 1884.

Augustus Loftus.

(Sig:245~)



A.D. 1884, 6th September. No. 1493.

IMPROVEMENTS IN SEWING MACHINES AND IN SPRING MOTORS FOR DRIVING
THE SAME.

LETTERS OF REGISTRATION to Alexander Watkins, for Improvements in
Sewing Machines and in Spring Motors for driving the same.

[Registered on the 6th day of September, 1884, in pursuance of the Act 16 Vic. No. 24.]

BY HIS EXCELLENCY THE RIGHT HONORABLE SIR AUGUSTUS WILLIAM FREDERICK SPENCER LOFTUS
(commonly called LORD AUGUSTUS LOFTUS), Knight Grand Cross of the Most Honorable Order of the
Bath, a Member of Her Majesty's Most Honorable Privy Council, Governor and Commander-in-Chief
of the Colony of New South Wales and its Dependencies.

TO ALL TO WHOM THESE PRESENTS SHALL COME, greeting :

WHEREAS ALEXANDER WATKINS, of London, England, horologist, hath by his Petition humbly represented to me that he is the author or designer of a certain invention or improvement in manufactures, that is to say, of an invention entitled "Improvements in Sewing Machines and in Spring Motors for driving the same," which is more particularly described in the specification, marked A, and the five sheets of drawings, marked B, C, D, E, and F respectively, which are hereunto annexed; and that he, the said Petitioner, hath deposited with the Honorable the Treasurer of the said Colony of New South Wales the sum of Twenty Pounds sterling, for defraying the expense of granting these Letters of Registration, as required by the Act of Council, sixteenth Victoria, number twenty-four; and hath humbly prayed that I would be pleased to grant Letters of Registration, whereby the exclusive enjoyment and advantage of the said invention or improvement might be secured to him for a period of fourteen years: And I, being willing to give encouragement to all inventions and improvements in the arts or manufactures which may be for the public good, and having received a report favourable to the prayer of the said Petition from competent persons appointed by me to examine and consider the matters stated therein and to report thereon for my information, am pleased, with the advice of the Executive Council, and in exercise of the power and authority given to me by the said Act of Council, to grant, and do by these Letters of Registration grant unto the said Alexander Watkins, his executors, administrators, and assigns, the exclusive enjoyment and advantage of the said invention or improvement for and during the term of fourteen years from the date hereof; to have, hold, and exercise unto the said Alexander Watkins, his executors, administrators, and assigns, the exclusive enjoyment and advantage thereof, for and during and unto the full end and term of fourteen years from the date of these presents next and immediately ensuing, and fully to be complete and ended: Provided always, that if the said Alexander Watkins shall not, within three days after the granting of these Letters of Registration, register the same in the proper office of the Supreme Court, at Sydney, in the said Colony of New South Wales, then these Letters of Registration, and all advantages whatsoever hereby granted, shall cease and become void.

In witness whereof, I have hereunto set my sign manual, and have caused the present Letters of Registration to be sealed with the seal of the said Colony of New South Wales, at Government House, Sydney, in New South Wales, this sixth day of September, in the year of our Lord one thousand eight hundred and eighty-four.

[L.S.]

AUGUSTUS LOFTUS.

Improvements in Sewing Machines and in Spring Motors for driving the same.

A.

SPECIFICATION of ALEXANDER WATKINS, of London, England, horologist, for an invention entitled "Improvements in Sewing Machines and in Spring Motors for driving the same."

My invention has for its object the construction of sewing machines in such a manner as to diminish friction in their working, and consequently the power required to drive them; and also the adaptation and application to such machines of mechanism by means of which they may be rendered self-acting.

Figure 1 is a side elevation, and figure 2 an end elevation of the sewing mechanism; figures 3 and 4 are side and end elevations respectively of the same.

Figures 5, 6, and 7 represent detached bearings of the sewing mechanism.

Figures 8 and 9 are details of improved apparatus for regulating the tension of the thread.

Figures 10 and 11 show a detail of the lower thread-holder.

Figure 12 shows a detail of an improved form of lifter for the presser bar.

The above-described figures (sheets 1 and 2) refer to the improvements in the sewing machine; and similar letters refer to like parts in the said different figures. The following sheets (3, 4, and 5) and figures thereon show the spring motor and details thereof, and like letters therein refer to similar parts.

Figures 13 and 14 show an instantaneous brake.

Figure 15 is a side elevation of a combined motor and sewing mechanism.

Figure 16 is an end view of the motor, and figure 17 shows an alternative form of spring, dispensing with the parabolic spiral.

Figures 18 and 19 show, in side and end elevation respectively, my automatic regulator.

Figure 20 shows the motor in plan, with over-winding and over-running stops in position.

Figure 21 shows detached detail of over-winding stop, and figure 22 shows detached detail of over-running stop.

First, to describe my improvements in the sewing mechanism (sheets 1 and 2). My improvements consist in constructing the machine throughout in such a manner as to diminish friction in the action of the working parts by diminishing the area of the surfaces in contact, and make these parts of steel and other hard materials adapted to resist wear in place of iron and the materials in ordinary use in sewing machines.

AA are the table and standards or frame of the machine; B is the main or driving shaft, to which manual or mechanical power is to be applied; C is a spur wheel on this shaft, gearing with the wheel D, to which is connected the light rod E, which is jointed to the lever bar F for working the needle. This lever bar F has its fulcrum at G, which it will be seen is about midway between the two ends of the lever, thereby balancing the lever, or nearly so, and diminishing the power required to work it. The requisite requisite throw for working the needle H is obtained by connecting the rod E to the wheel D, in the manner shown in figure 2, whereby the end of the rod has a suitable crank motion imparted to it. By this arrangement it will be seen that the power required to work the needle from the driving shaft is greatly diminished.

I is the looper shaft, which is driven by the wheel D, and is mounted so as to turn in hard steel bearings. This shaft is formed with a small journal at each end, as shown in figure 5, the journal at the end nearest the wheel D passing through a steel collar K inserted in the bearing of the shaft, and the journal at the other end having on it the eccentric for driving the looper, and working in a steel collar inserted in the bearing L; in each case the frictional surface in contact with the journal is only of the width of the collar in which the journal works. Figure 6 shows the steel collar K, and figure 7 the steel collar in the bearing L. By forming and mounting the shaft in this manner a great diminution of bearing and frictional surface is secured, and wear of the parts is prevented by making them of steel or other suitable hard material.

M (figure 3) is the presser bar, the friction in the working of which is diminished by substituting for the ordinary spiral spring round a vertical spindle a flat spring N, the end of which is passed through an aperture in the bar, in which are formed slots to admit of the slight vertical movements of the bar on fixed studs, which, with the slots, serve as guides for the bar.

O is a vertical screw rod, with a button at the top, by turning which the rod will be screwed down on a spring brake P, and cause the same to press on a small wheel Q on the shaft of the wheel D, and thereby stop or retard the motion of the machine, as may be required. On raising the rod O, by turning the screw in the reverse direction, the wheel Q will be released from pressure by the reaction of the spring fixed to the brake P.

R is the ordinary bobbin for supplying the thread to the needle. This bobbin is arranged so as to admit of the thread being passed to the needle in a more direct manner than usual, thereby preventing the friction due to the ordinary arrangements of passing the thread through intermediate guides. The bottom flange of the bobbin rests on a spring S, and the tension of the thread is regulated, as required, by pressing the said flange on to the spring by means of a button T at the top of the bobbin.

U is a fly-wheel for equalizing the motion of the machine.

From the foregoing description it will be readily understood that the machine is so constructed throughout as greatly to reduce the friction of the working parts, and consequently to diminish in the same proportion the amount of power required to work the machine, thereby greatly facilitating the means of rendering the machine self-acting when required. And this is the more important, because while on the one hand the labour of working machines of the ordinary construction has been found to be highly injurious to female workers, on the other hand the amount of power required has made it difficult to adapt self-acting means for working them.

With regard to the further alternative and improved details of my sewing mechanism, in figures 8 and 9, *a* and *b* are two plates, mounted as shown, the upper plate *a* being formed as shown in figure 9, and the lower plate *b* being a simple disc. The requisite tension is applied to the thread by means of a screw within the spiral spring

Improvements in Sewing Machines and in Spring Motors for driving the same.

In figures 10 and 11 is represented the lower thread-holder, consisting of a small bar, screwed on to a movable or adjustable plate, to which bar is fixed a spring, on the end of which is fitted a brush *d* to hold the loop previous to its being drawn up; *e* is a screw by which the position of the brush can be adjusted as required.

In these two figures is also represented the improved arrangement for working the looper; *f* is a pinion fixed on the looper shaft, and *g* the disc which holds the looper; *h* is a pinion nut of larger diameter than the pinion *f*. On the pinion nut is fixed an eccentric *i* which revolves with the said pinion *f* and pinion nut *h*, thereby moving the work along as required.

In figures 13 and 14 is represented an instantaneous brake, which may be applied in addition to the gradual brake hereinbefore specified; *j* is a lever bar having its fulcrum at *k*, which is caused to act on a spring *l* screwed at one end to the base plate or board A, the other part of the spring being curved so as to press on the circumference of the metal disc *n* on the looper shaft.

At figure 12 is represented the lifter for the presser bar with slots *o, o*, as shown at the top and bottom of the plate, and also an intermediate slot, so as to ease the motion in lifting the foot and presser bar by providing additional points as guides for the sliding plate.

I combine the improved sewing mechanism as above described with a spring motor mechanism to render the sewing machine self-acting, after the motor is wound up.

The following is a description of the said spring motor mechanism (shown on sheets 3, 4, and 5).

Figure 15 is a front elevation of the machine with the improved driving apparatus combined therewith, and figure 16 is an end elevation of same. A is the base plate or board on which the sewing mechanism rests, underneath which plate the driving apparatus is enclosed within a box or case only partially shown in the figures.

B is a shaft on which is a pinion C gearing with a wheel D on the axis of the parabolic spiral E, to which is connected one end of a line or chain F, the other end of which is fixed to the block or solid cylinder of wood G, mounted so as to turn in journals, and having a shaft H, on which is fixed the roller with flanges (shown by dotted lines) to which are fastened one end of each of the volute springs I, I, the other end of each spring being fastened to the back of the box or casing, or to a horizontal bar or rod provided with suitable hooks for the purpose.

By means of the foregoing arrangement of the parts, on applying a key to the square end of the shaft B, the parabolic spiral will be turned on its axis, and thereby caused to take up the line or chain F as it is unwound from the block or solid cylinder G, which will be turned so as to give motion to the roller with its flanges, to which one end of each spring I is fastened, and thereby cause all the springs to be simultaneously wound up, the requisite amount of mechanical force being thus stored up in readiness to work the machine by the gradual reaction of the springs I, I, through the gearing, by which motion is conveyed from the parabolic spiral to the main shaft of the machine.

This gearing consists of the toothed wheel J working in the pinion K, on the shaft of which is the wheel L working in the pinion M, the shaft of which carries the wheel N which transmits motion to the pinion O on the driving shaft P of the machine, thereby giving motion to the several working parts of the sewing mechanism.

A modification of the above arrangement may be made to consist in dispensing with the parabolic spiral E, the line or chain F, and the cylinder G, and placing the toothed wheel J on the end of one of the flanged rollers or on the end of the shaft H, the remainder of the gearing being as represented and described. In this case the springs I will be tapered. This modification is represented in figure 17 with one tapered spring.

To better govern the speed of my sewing machine, I apply an automatic regulator shown in figures 18 and 19.

My regulating device consists of one or a number of hollow arms or tubes Q, projecting radially from a boss R, the said boss being keyed securely upon one of the revolving shafts of the motor mechanism, preferably on the one revolving at the highest speed.

The radial hollow arms contain spiral springs, or other elastically resisting material, S. A spindle provided with a weighted pad or foot T outside the end of the tube, passes through the centre of the spiral spring or other elastic medium, and reacts against the base of the spring or elastic medium by a collar upon the end of the said spindle. The spring is prevented from coming out of the end of the tubular arms by a shoulder-piece screwed thereon, or otherwise attached thereto.

At the bottom of each tubular arm, and below the spiral spring, is placed a loose piece or ball of metal, or alternatively, the said spiral spring may be secured by soldering, or in any other suitable manner, to the bottom of the tube Q, a weighted pad of leather or other material T being soldered or otherwise attached to the outer extremity of the spring. When the said radial tubes revolve, the centrifugal force so generated will cause the said metal weight (whether attached to the pad or loose), and also the spindle, to fly radially outwards from the revolving axis against the reacting elasticity of the spring, and thus cause the projecting feet of the spindle or pads to come in contact with the inner circumference of a surrounding ring, held stationary with the framing, and thus to produce retardation of the speed.

The exterior surface of the radial feet or pads and the inner circumference of the said ring may be covered, if desired, with wood, leather, or any other desirable substance, or may have polished metallic faces.

The external retarding ring V is preferably not a complete ring, but has its two extremities turned outwards, as lugs *v* and *v'*, at right angles to the rest of the ring.

Through these two lugs I pass a thumbscrew X, tapped into the further lug *v'*, with a collar upon its spindle pressing on the nearer lug *v*, or fitted in any other known manner, so that the lugs are drawn closer together, and the ring V thereby reduced in diameter, when the thumbscrew is rotated in one direction; and *vice versa*, the ring is expanded when the movement of the thumbscrew is reversed.

In order to ensure that the said external ring shall close in such a manner over the greater part of its circumference, so as to maintain its true circular shape, we may make the ring of varying section, either as regards its width or thickness, so as to prevent distortion at those points nearest to the adjusting screw.

This

Improvements in Sewing Machines and in Spring Motors for driving the same.

This device enables the operator to vary at will the maximum speed at which the retarding feet come into contact with the external ring by the opening or closing of said ring as described.

The rotating tubular arms may be enclosed by a suitable case, and the adjustable ring may be attached thereto in such a way as not to interfere with its closing and expanding movements.

To prevent overwinding, I add a lever T (figures 2 and 21), rocking on a pivot fixed in the frame. The lower end of the said lever, being thrust outwards by the last length of the chain as it is wound up upon the parabolic spiral, throws the upper end of the lever against a stop *w* on the winding axle, which will check the winding up at the desired point.

There is also a stop Y (figures 20 and 22) added to the machine to prevent the over running down of the chain. The last length of the chain, as it unwinds from the parabolic spiral, presses against the lever Y rocking on a pivot *y*, which, by the friction of the pad V¹¹, stops the fly-wheel U.

CLAIMS.

- First. The general arrangement and construction of the sewing mechanism in its various parts, so as to reduce friction in the working thereof, as hereinbefore described.
- Second. The arrangement described for balancing and working the lever bar for working the needle.
- Third. The mode described of forming and mounting the shaft for working the looper.
- Fourth. The arrangement described for working the presser bar.
- Fifth. The spring brake for stopping and regulating the motions of the machine, as hereinbefore described.
- Sixth. The combination of parts employed for regulating the tension of the thread, constructed in the manner substantially as described and illustrated in figures 8 and 9.
- Seventh. The construction of a lower thread-holder, substantially as described in reference to figures 10 and 11.
- Eighth. The construction of an instantaneous brake, substantially as described in reference to figures 13 and 14.
- Ninth. The driving mechanism, consisting of a spring with a parabolic spiral, or a graduated spring, or a weight or spring and spur gearing, as hereinbefore described.
- Tenth. The regulating mechanism, operating automatically by centrifugal force, and with adjustable ring, as described in reference to figures 18 and 19.
- Eleventh. In a sewing machine, the combination of a spring motor mechanism, automatically controlled by a centrifugal regulator, both as hereinbefore claimed and described, with a sewing mechanism, as hereinbefore claimed, to render the same self-acting.

In witness whereof, I, the said Alexander Watkins, have hereto set my hand and seal, this seventeenth day of March, 1884.

ALEX. WATKINS.

Witnesses—

WILLIAM O. HEWLETT, Solicitor,
2, Raymond Buildings, Gray's Inn, London.
SAM. P. WILDING, Patent Agent,
23, Rood Lane, London.

This is the specification marked A referred to in the annexed Letters of Registration granted to Alexander Watkins, the sixth day of September, A.D. 1884.

AUGUSTUS LOFTUS.

REPORT.

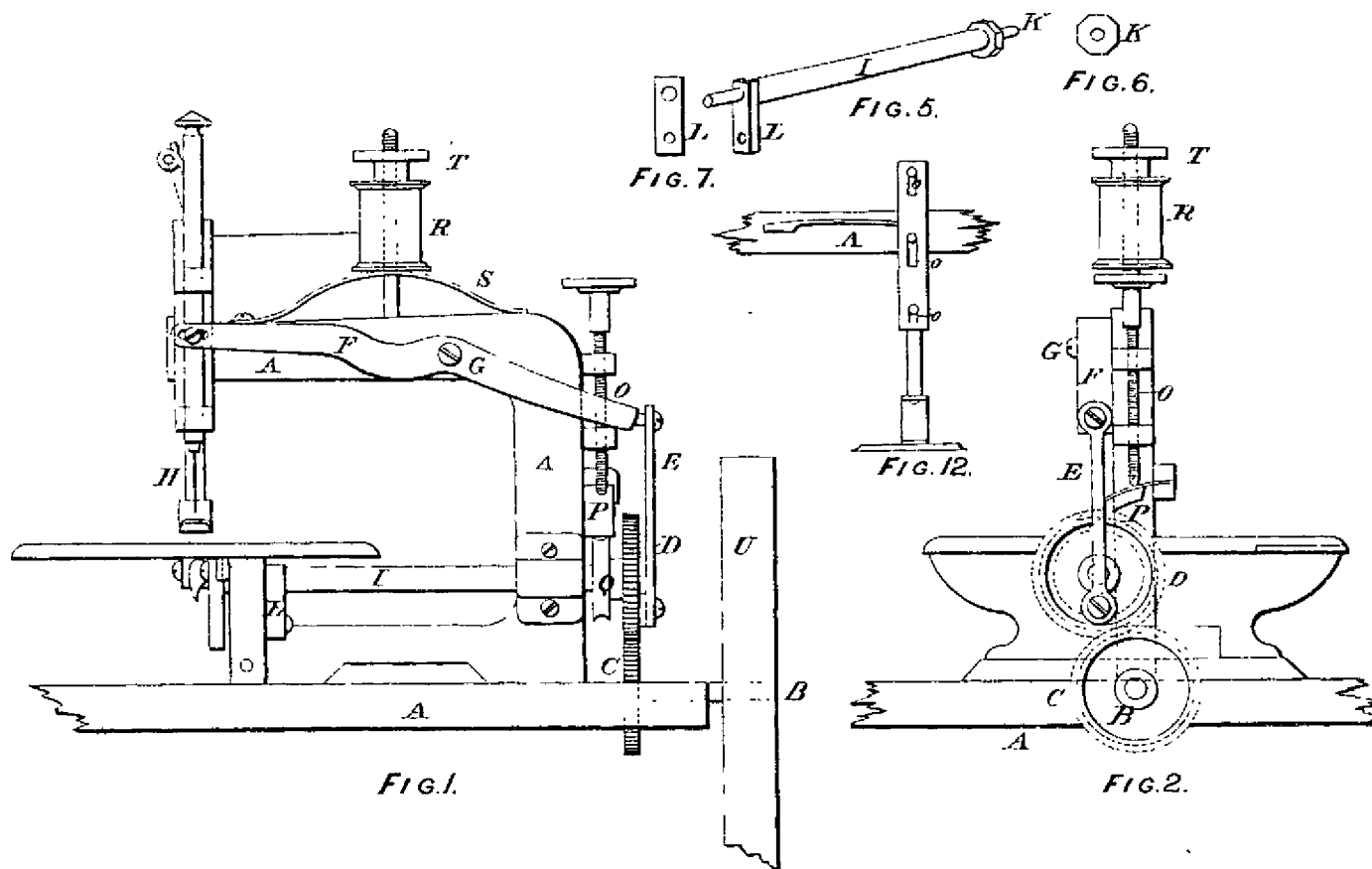
Sir,

Sydney, 22 July, 1884.

We do ourselves the honor to report, in reply to your blank cover of the 10th instant, No. 7473, transmitting the Petition of Mr. Alexander Watkins for the registration of an invention entitled "Improvements in Sewing Machines and in Spring Motors for driving the same," that we are of opinion the prayer of the Petitioner may be granted.

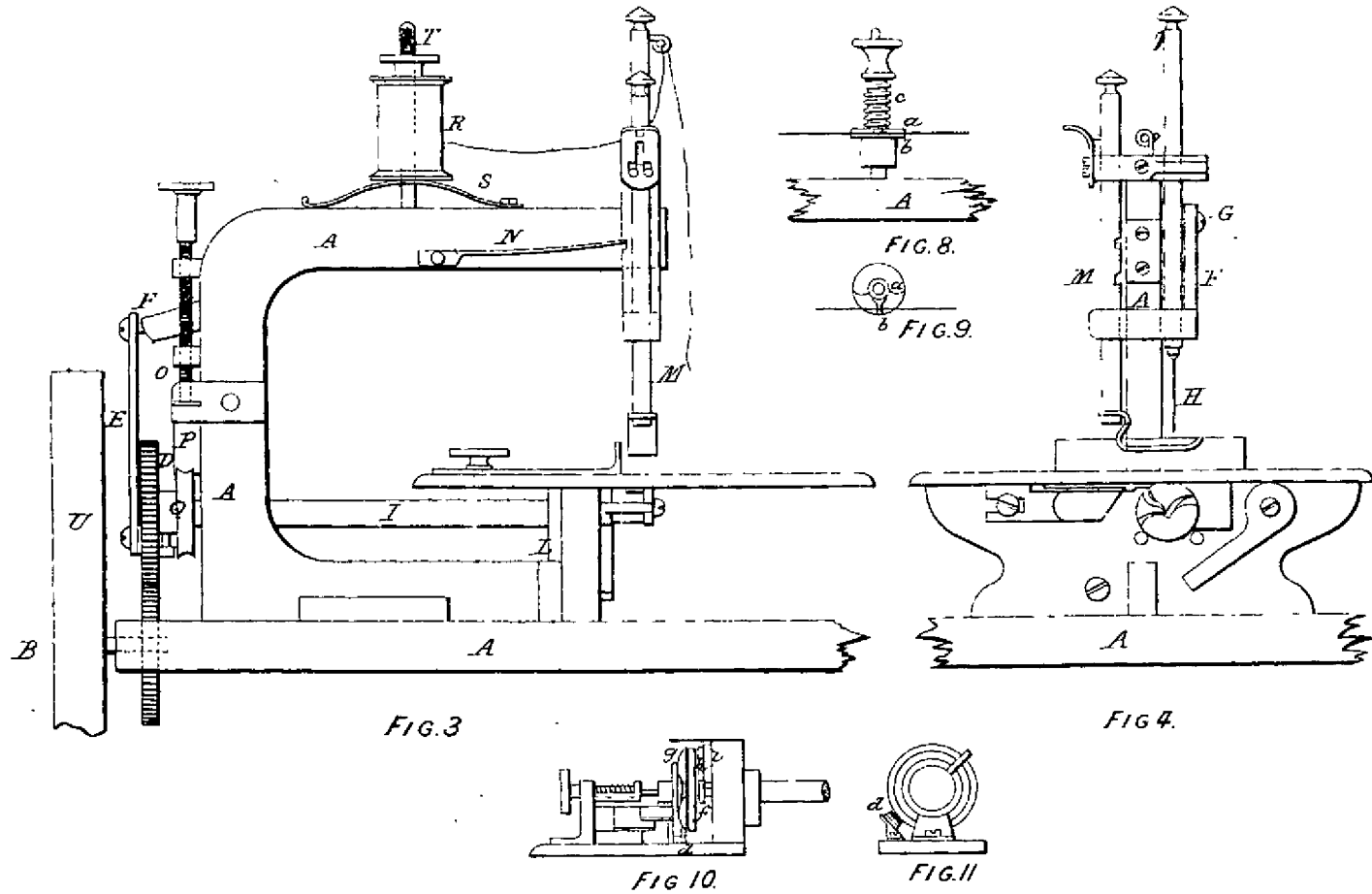
We have, &c.,
EDMUND FOSBERY.
GOTHEK K. MANN.

The Under Secretary of Justice.



This is the Sheet of Drawings marked B, referred to in the annexed Letters of Registration, granted to Alexander Watkins, the sixth day of September, A. D., 1884.

Augustus Loftus.



This is the Sheet of Drawings marked, C referred to in the annexed Letters of Registration, granted to Alexander Watkins, the sixth day of September, A. D., 1884.

Augustus Loftus.

(Sig: 245-)

FIG. 16.

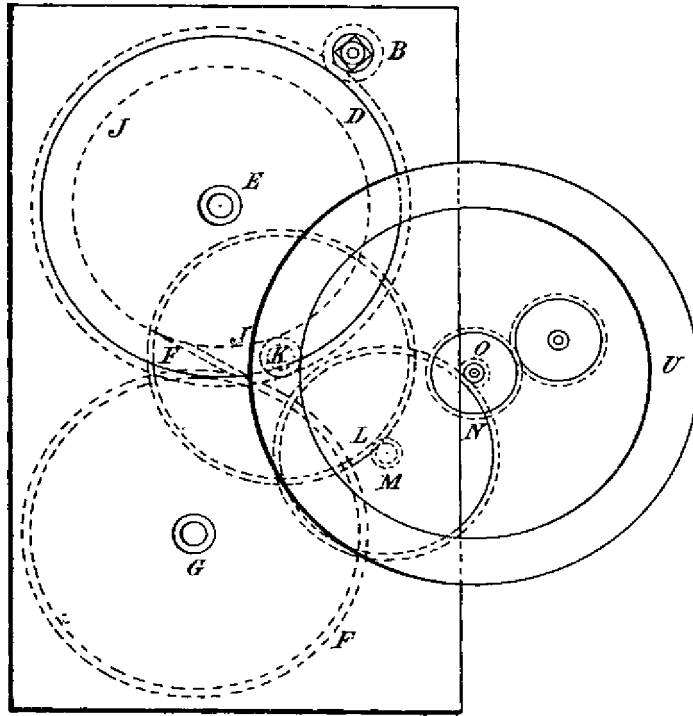


FIG. 13.

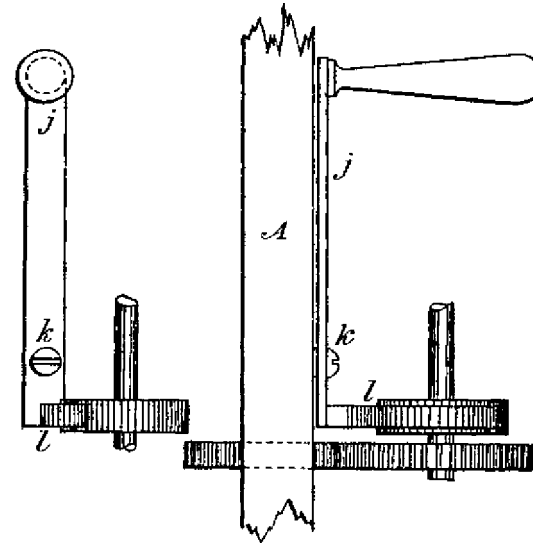
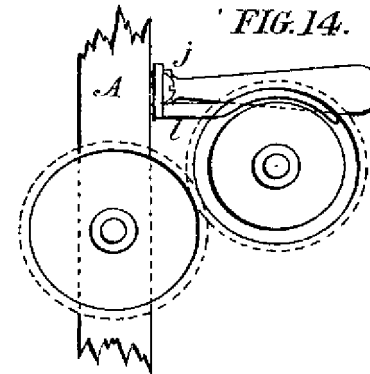


FIG. 14.



*This is the Sheet of Drawings marked D, referred to in the annexed
Letters of Registration, granted to Alexander Watkins, the sixth day of
September, A. D., 1884.*

Augustus Loftus.

(Sig: 245~)

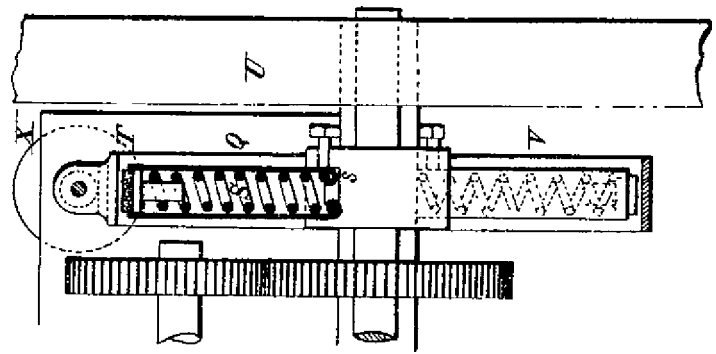
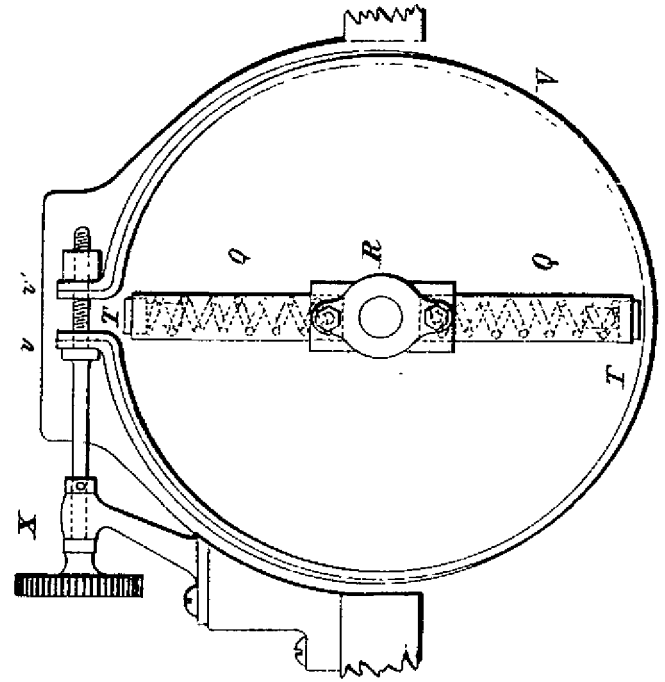


FIG. 19.

FIG. 18.

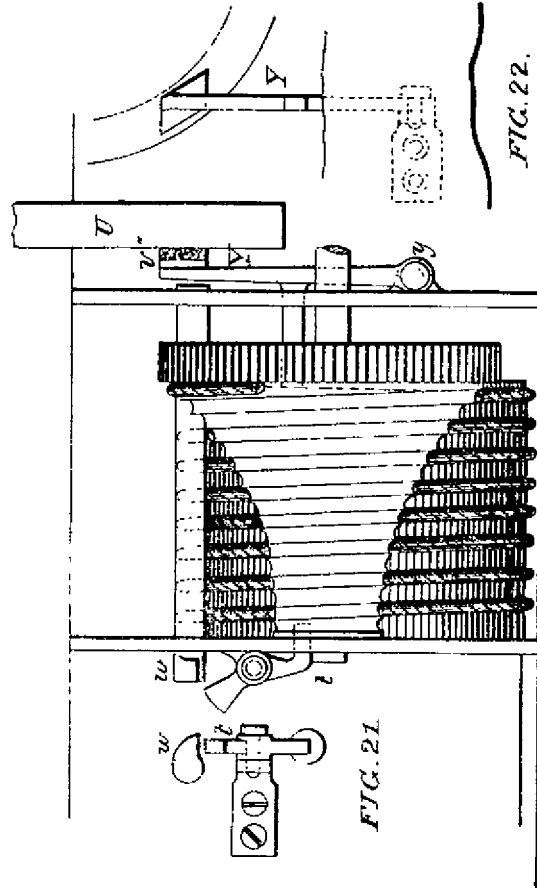


FIG. 20.

FIG. 21.

FIG. 22.

This is the Sheet of Drawings marked F, referred to in the annexed Letters of Registration, granted to Alexander Watkins, the sixth day of September, A. D., 1884. Augustus Loftus.

(Sig: 245~)



A.D. 1884, 6th September. No. 1494.

IMPROVEMENTS IN MACHINES FOR GRUBBING OR EXTRACTING ROOTS
AND TREES.

LETTERS OF REGISTRATION to John Rowland Dacey, for Improvements
in Machines for Grubbing or Extracting Roots and Trees.

[Registered on the 6th day of September, 1884, in pursuance of the Act 16 Vic. No. 24.]

BY HIS EXCELLENCY THE RIGHT HONORABLE SIR AUGUSTUS WILLIAM FREDERICK SPENCER LOFTUS,
(commonly called LORD AUGUSTUS LOFTUS), Knight Grand Cross of the Most Honorable Order of the
Bath, a Member of Her Majesty's Most Honorable Privy Council, Governor and Commander-in-Chief
of the Colony of New South Wales and its Dependencies.

TO ALL TO WHOM THESE PRESENTS SHALL COME, greeting :

WHEREAS JOHN ROWLAND DACEY, of No. 87, Lower Fort-street, Sydney, in the Colony of New South Wales, blacksmith, hath by his Petition humbly represented to me that he is the author or designer of a certain invention or improvement in manufactures, that is to say, of an invention entitled "Improvements in Machines for Grubbing or Extracting Roots and Trees," which is more particularly described in the specification and the sheet of drawings which are hereunto annexed ; and that he, the said Petitioner, hath deposited with the Honorable the Treasurer of the said Colony of New South Wales the sum of Twenty Pounds sterling, for defraying the expense of granting these Letters of Registration, as required by the Act of Council, sixteenth Victoria, number twenty-four ; and hath humbly prayed that I would be pleased to grant Letters of Registration, whereby the exclusive enjoyment and advantage of the said invention or improvement might be secured to him for a period of fourteen years : And I, being willing to give encouragement to all inventions and improvements in the arts or manufactures which may be for the public good, and having received a report favourable to the prayer of the said Petition, from competent persons appointed by me to examine and consider the matters stated therein and to report thereon for my information, am pleased, with the advice of the Executive Council, and in exercise of the power and authority given to me by the said Act of Council, to grant, and do by these Letters of Registration grant unto the said John Rowland Dacey, his executors, administrators, and assigns, the exclusive enjoyment and advantage of the said invention or improvement, for and during the term of fourteen years from the date hereof ; to have, hold, and exercise unto the said John Rowland Dacey, his executors, administrators, and assigns, the exclusive enjoyment and advantage thereof, for and during and unto the full end and term of fourteen years from the date of these presents next and immediately ensuing, and fully to be complete and ended : Provided always, that if the said John Rowland Dacey shall not, within three days after the granting of these Letters of Registration, register the same in the proper office in the Supreme Court, at Sydney, in the said Colony of New South Wales, then these Letters of Registration, and all advantages whatsoever hereby granted, shall cease and become void.

In witness whereof, I have hereunto set my sign manual, and have caused the present Letters of Registration to be sealed with the seal of the said Colony of New South Wales, at Government House, Sydney, in New South Wales, this sixth day of September, in the year of our Lord one thousand eight hundred and eighty-four.

[L.S.]

AUGUSTUS LOFTUS.

Improvements in Machines for Grubbing or Extracting Roots and Trees.

SPECIFICATION of John Rowland Dacey, of No. 87, Lower Fort-street, Sydney, in the Colony of New South Wales, blacksmith, for an invention entitled "Improvements in Machines for Grubbing or Extracting Roots and Trees."

My improvements relate to that class of machines for grubbing or extracting roots and trees, in which the strain is put upon the stump or tree to be extracted by means of a lever working back along a fixed anchor-plate against movable fulcra, and it has been designed in order to reduce the weight, to increase the power, and to make such machines more convenient in operation.

My first improvement consists in making the lever head or end with two straps, between which the lever-beam is grasped sideways, the said beam "butting" right up against the mortise in said head. My second improvement consists in the use of flat-headed or L shaped pins for insertion in the perforations in the anchor-plate to form the fulcra, so that the shackle will pass over such flat or L heads. And my third improvement consists in the use of a supplementary shackle and chain for taking the strain when the lever has traversed backward along the anchor-plate.

But, in order that I may be clearly understood, I will now make reference to the drawings hereto attached, in which fig. 1 is a plan of my improved machine for grubbing or extracting roots and trees, while figs. 2 and 3 show, on a larger scale, plan and side view respectively of the lever head or end. A is the beam, B its head, C the anchor-plate, D the fulcra pins, E the shackle, F supplementary shackle, and G slack rods or side-shackles. A¹ are fastening bolts, B¹ side straps, B² fulcra notches, B³ holes for pins of shackles G, C¹ are perforations, C² guide staple, C³ chain attachments, D¹ are the flat heads, E¹ are studs or pintles of the shackle E, E² is chain or links, E³ short rods, and E⁴ long rods.

In operation, anchor-plate C is firmly fixed or permanently attached to a tree or stump or some fixed object by attachments C³, while attachments E², E³, and E⁴, as many as are required are made fast at one end to the tree or stump to be extracted, and at the other to the shackle E. Slack rods or side-shackles G are fixed to lever head B by pins inserted in holes B³, and the lever worked against one of the flat-headed fulcra pins D, until the slack of the attachments is taken up, after which the greater leverage is brought into play by working against the fulcra pins D (two of which are supplied) in notches B² alternately, the shackle E taking the strain. When the lever A, with its head B, has traversed the whole length of the anchor-plate C, the shackle F is pinned through one or other perforation C¹, in such plate, and its other end fastened short by links or a hook to the attachments E², E³, or E⁴, and the lever worked to relieve the strain from the shackle E, which strain is then taken by supplementary shackle F, when the head B may be returned to the foremost end of the anchor-plate C, the attachments E², E³, or E⁴ shortened as much as possible, and the lever A again brought into play against the fulcra pins D. This shortening of the attachments and working of the lever back over the anchor-plate may be repeated until the tree or stump is extracted.

Referring to my first improvement I may add that it has heretofore been deemed impracticable to construct the lever head with the beam "butting" up against the slot or mortise, and with two side-straps, and they have hitherto been constructed with a solid piece of metal, say 18 inches in length between the straps and the head, and with straps, not at the sides of the beam, but at top or bottom; but I make the head much lighter by dispensing with the 18 inches of intervening metal, and by having the straps on the sides reduce the strain upon the fastening bolts. By my second improvement, as will be seen, I am enabled to place the notches B² much closer to one another, and thus get the fulcra closer to the shackle studs E¹, and considerably increase the leverage of the beam without increasing its length. By my third improvement I dispense with the necessity of altering the anchor-plate attachments after they are once fixed, and for releasing the strain upon the tree or stump until it is extracted. The rods I use I make of stouter metal at the links or hooks than that in the shanks.

Having thus particularly described and ascertained the nature of my said invention, and the manner in which the same is to be performed, I would have it understood that what I believe to be novel, and therefore claim as my improvements in machines for grubbing or extracting roots and trees is—

First—Constructing the lever head or end B with the side-straps B¹, between which the beam is bolted "butt" up against the slot or mortise, substantially as herein described and explained, and as illustrated in the drawings.

Second—The combination with the lever head or end B, having notches B² of the flat-headed or L shaped pins D for insertion in the perforations of the anchor-plate C, substantially as herein described, and as illustrated in the drawings.

Third—The combination, with the anchor-plate C, and the attachments E², E³, or E⁴ of the supplementary shackle and chain F, to take the strain while the length of such attachments is being shortened, substantially as herein described and explained, and as illustrated in the drawings.

In witness whereof, I, the said John Rowland Dacey, have hereto set my hand and seal, this eighth day of July, one thousand eight hundred and eighty-four.

Witness—

FRED. WALSH,

Manager, E. Waters' Patent Office, Sydney.

JOHN ROWLAND DACEY.

This is the specification referred to in the annexed Letters of Registration granted to John Rowland Dacey, the sixth day of September, A.D. 1884.

AUGUSTUS LOFTUS.

REPORT.

Sir,

We do ourselves the honor to report, in reply to your blank cover of the 12th instant, No. 7,412, transmitting the petition of Mr. John Rowland Dacey, for the registration of an invention entitled "Improvements in Machine for Grubbing or Extracting Roots and Trees," that we are of opinion the prayer of the petitioner may be granted.

The Under Secretary of Justice.

Sydney, 22 July, 1884.

We have, &c.,

E. C. CRACKNELL.

GOTHER K. MANN.

[Drawings—one sheet.]

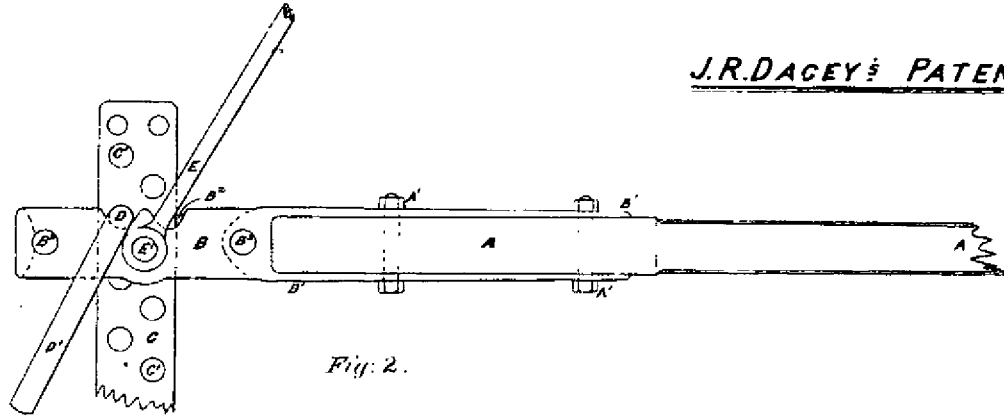
J.R. DACEY'S PATENT.

Fig. 2.

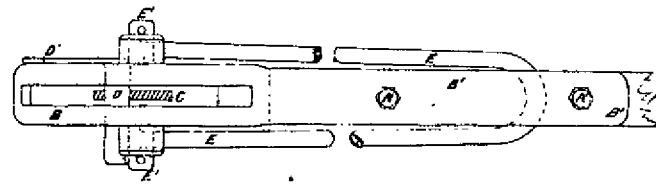


Fig. 3.

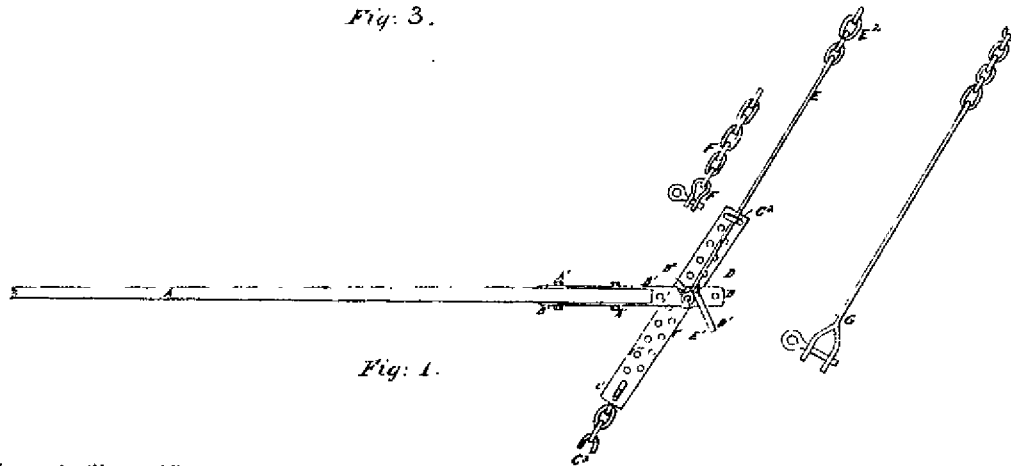


Fig. 1.

This is the Sheet of Drawings referred to in the annexed Letters of Registration, granted to John Rowland Dacey, the sixth day of September, A. D., 1884. *Augustus Loftus.*



A.D. 1884, 13th September. No. 1495.

IMPROVEMENTS IN THE MANUFACTURE OF ARTIFICIAL FUEL.

LETTERS OF REGISTRATION to Jason Irving, for Improvements in the
Manufacture of Artificial Fuel.

[Registered on the 13th day of September, 1884, in pursuance of the Act 16 Vic. No. 24.]

BY HIS EXCELLENCY THE RIGHT HONORABLE SIR AUGUSTUS WILLIAM FREDERICK SPENCER LOFTUS (commonly called LORD AUGUSTUS LOFTUS), Knight Grand Cross of the Most Honorable Order of the Bath, a Member of Her Majesty's Most Honorable Privy Council, Governor and Commander-in-Chief of the Colony of New South Wales and its Dependencies.

TO ALL TO WHOM THESE PRESENTS SHALL COME, greeting :

WHEREAS JASON IRVING, of Sydney, in the Colony of New South Wales, engineer, hath by his Petition humbly represented to me that he is the author or designer of a certain invention or improvement in manufactures, that is to say, of an invention entitled "Improvements in the Manufacture of Artificial Fuel," which is more particularly described in the specification which is hereunto annexed ; and that he, the said Petitioner, hath deposited with the Honorable the Treasurer of the said Colony of New South Wales the sum of Twenty Pounds sterling for defraying the expense of granting these Letters of Registration, as required by the Act of Council, sixteenth Victoria number twenty-four ; and hath humbly prayed that I would be pleased to grant Letters of Registration, whereby the exclusive enjoyment and advantage of the said invention or improvement might be secured to him for a period of fourteen years : And I, being willing to give encouragement to all inventions and improvements in the arts or manufactures which may be for the public good, and having received a report favourable to the prayer of the said Petition from competent persons appointed by me to examine and consider the matters stated therein and to report thereon for my information, am pleased, with the advice of the Executive Council, and in exercise of the power and authority given to me by the said Act of Council, to grant, and do by these Letters of Registration grant unto the said Jason Irving, his executors, administrators, and assigns, the exclusive enjoyment and advantage of the said invention or improvement, for and during the term of fourteen years from the date hereof ; to have, hold, and exercise unto the said Jason Irving, his executors, administrators, and assigns, the exclusive enjoyment and advantage thereof for and during and unto the full end and term of fourteen years from the date of these presents next and immediately ensuing, and fully to be complete and ended : Provided always, that if the said Jason Irving shall not, within three days after the granting of these Letters of Registration, register the same in the proper office in the Supreme Court, at Sydney, in the said Colony of New South Wales, then these Letters of Registration and all advantages whatsoever hereby granted, shall cease and become void.

In witness whereof, I have hereunto set my sign manual, and have caused the present Letters of Registration to be sealed with the seal of the said Colony of New South Wales, at Government House, Sydney, in New South Wales, this thirteenth day of September, in the year of our Lord one thousand eight hundred and eighty-four.

[L.s.]

AUGUSTUS LOFTUS.

Improvements in the Manufacture of Artificial Fuel.

SPECIFICATION of JASON IRVING, of Sydney, in the Colony of New South Wales, engineer, for an invention entitled "Improvements in the Manufacture of Artificial Fuel."

THIS invention has been devised, in order to produce an artificial fuel that has neither (or very little) taste nor smell, and which, when burning, gives off no, or a minimum of, noxious vapours and smoke, and which is produced in a speedy, cleanly, and economical manner. By it I utilize the small coal and coal-dust, or slack, which has heretofore been thrown aside as of very little value.

My improvements consist essentially in the consolidation of small coal and coal-dust, by means of a peculiar fluid or mixture into blocks or pieces of a size convenient for handling and for promoting their own combustion.

To make, say, a ton of my artificial fuel, I take of a meal or flour—preferably maize or Indian corn meal—say thirty pounds weight, and boil it in, say, from twenty to fifty gallons of water, and when ebullition commences I add, say, ten pounds weight of unslaked lime, and remove the scum which rises to the surface. When the boiling mixture has reached a certain stage, the knowledge of which I have gained by experience, and which I judge to have arrived when the mixture takes a second colour, I add, say, one pound of potash, preferably nitrate of potassa, and continue boiling until the mixture is of a consistency suitable for mixing with the coal-dust and small coal, with which it is incorporated, while still hot, in a manner similar to that of water with flour in the manufacture of dough, and the product, while moist, is shaped as desired, either by machinery or by hand, and then allowed to dry, or is dried in ovens.

I use the meal or flour on account of the unctuous or glutinous nature of the fluid, in which it has been boiled, and I consider that any other substance which will give a like result might be used as a substitute for it, although I believe that the meal of maize or Indian corn is the best suited for the purpose. I add the lime to correct any acidity or acidulous tendency of the fluid, as well as to harden the completed fuel; and the potash is used as a cleansing or purifying medium, and also to assist in the combustion of the fuel.

Having thus described and ascertained the nature of the said invention, and the manner in which the same is to be performed, I would have it understood that I do not confine myself to the particular proportions or measures of quantities, which I have hereinbefore set forth as being used in the manufacture of my artificial fuel, so long as the nature of my invention be retained; but what I claim is—

First—A mixture or fluid, produced by boiling meal or flour in water, and to which lime and potash have been added, substantially as herein described and explained, for consolidating coal and coal-dust into blocks or lumps.

Second—The various steps combined and arranged for manufacturing artificial fuel, substantially as herein described and explained.

In witness whereof, I, the said Jason Irving, have hereto set my hand and seal, this twenty-fifth day of August, one thousand eight hundred and eighty-four.

Witnesses—

ROB. SCOTT ROSS.

FRED. WALSH.

JASON IRVING.

This is the specification referred to in the annexed Letters of Registration granted to Jason Irving the thirteenth day of September, A.D. 1884.

AUGUSTUS LOFTUS.

REPORT.

Sir,

We do ourselves the honor to report, in reply to your blank cover of the 26th instant, transmitting Mr. Jason Irving's Petition for the registration of an invention entitled "Improvements in the Manufacture of Artificial Fuel," that we are of opinion the prayer of the Petitioner may be granted, in terms of his specification and claim.

We have, &c,

E. C. CRACKNELL.

GOTHER K. MANN.

The Under Secretary of Justice.



A.D. 1884, 13th September. No. 1496.

**IMPROVEMENTS IN THE EXTRACTION OF COBALT, NICKEL, AND MANGANESE
FROM THEIR ORES, &c.**

LETTERS OF REGISTRATION to Henri Herrenschmidt, Marmaduke Constable, Francis Lord, and David Wilson, for Improvements in the extraction of cobalt, nickel, and manganese from their ores, and of nickel from its ores, where such ores are found in a similar condition to those of New Caledonia.

[Registered on the 15th day of September, 1884, in pursuance of the Act 16 Vic. No. 24.]

BY HIS EXCELLENCY THE RIGHT HONORABLE SIR AUGUSTUS WILLIAM FREDERICK SPENCER LOFTUS (commonly called LORD AUGUSTUS LOFTUS), Knight Grand Cross of the Most Honorable Order of the Bath, a Member of Her Majesty's Most Honorable Privy Council, Governor and Commander-in-Chief of the Colony of New South Wales and its Dependencies.

TO ALL TO WHOM THESE PRESENTS SHALL COME, greeting:

WHEREAS HENRI HERRENSCHMIDT, of Bondi, near Sydney, in the Colony of New South Wales, metallurgist, MARMADUKE CONSTABLE, of Balmain, near Sydney aforesaid, gentleman, FRANCIS LORD, of St. Leonards, near Sydney aforesaid, gentleman, and DAVID WILSON, of Spring-street, Sydney aforesaid, gentleman, have by their Petition humbly represented to me that your Petitioner Henri Herrenschmidt, is the author or designer of a certain invention or improvement in manufactures, that is to say, of an invention entitled "Improvements in the extraction of cobalt, nickel, and manganese from their ores, and of nickel from its ores, where such ores are found in a similar condition to those of New Caledonia," which invention is more particularly described in the specification which is hereto annexed; and your Petitioners, Marmaduke Constable, Francis Lord, and David Wilson are the assignees from the said Henri Herrenschmidt of certain interests in the said invention; and that they, the said Petitioners, have deposited with the Honorable the Treasurer of the Colony of New South Wales the sum of Twenty Pounds sterling, for defraying the expense of granting these Letters of Registration, as required by the Act of Council, sixteenth Victoria number twenty-four; and have humbly prayed that I would be pleased to grant Letters of Registration, whereby the exclusive enjoyment and advantage of the said invention or improvement might be secured to them for a period of fourteen years: And I, being willing to give encouragement to all inventions and improvements in the arts or manufactures which may be for the public good, and having received a report favourable to the prayer of the said Petition, from competent persons appointed by me to examine and consider the matters stated therein and to report thereon for my information, am pleased, with the advice of the Executive Council, and in exercise of the power and authority given to me by the said Act of Council, to grant, and do by these Letters of Registration grant unto the said Henri Herrenschmidt, Marmaduke Constable, Francis Lord, and David Wilson, their executors, administrators, and assigns, the exclusive enjoyment and advantage of the said invention or improvement, for and during the term of fourteen years from the date hereof; to have, hold, and exercise unto the said Henri Herrenschmidt, Marmaduke Constable, Francis Lord, and David Wilson, their executors, administrators, and assigns, the exclusive enjoyment and advantage thereof, for and during and unto the full end and term of fourteen years from the date of these presents next and immediately ensuing, and fully to be complete and ended: Provided always, that if the said Henri Herrenschmidt, Marmaduke Constable, Francis Lord, and David Wilson shall not, within three days after the granting of these Letters of Registration, register the same in the proper office in the Supreme Court, at Sydney, in the said Colony of New South Wales, then these Letters of Registration, and all advantages whatsoever hereby granted, shall cease and become void.

In witness whereof, I have hereunto set my sign manual, and have caused the present Letters of Registration to be sealed with the seal of the said Colony of New South Wales, at Government House, Sydney, in New South Wales, this thirteenth day of September, in the year of our Lord one thousand eight hundred and eighty-four.

[T.S.]

AUGUSTUS LOFTUS.
SPECIFICATION

Improvements in the extraction of cobalt, nickel, and manganese from their ores, &c.

SPECIFICATION of HENRI HERRENSCHMIDT, of Bondi, near Sydney, in the Colony of New South Wales, metallurgist, MARMADUKE CONSTABLE, of Balmain, near Sydney aforesaid, gentleman, FRANCIS LORD, of St. Leonards, near Sydney aforesaid, and DAVID WILSON, of Spring-street, Sydney aforesaid, the assignees of the said Henri Herrenschildt, the inventor of an invention entitled "Improvements in the extraction of cobalt, nickel, and manganese from their ores, and of nickel from its ores, when such ores are found in a similar condition to those of New Caledonia."

OUR invention has been designed for the purpose of treating two kinds of ore found in New Caledonia in one succession of operations, forming a complete process, some of which operations, however, may be used separate and apart from the others. The two kinds of ore we refer to are—first, the manganiferous ores of cobalt and nickel, and second, the plain ores of nickel.

Supposing that we have both these ores to treat, we take the manganiferous cobalt and nickel ore first, and treat it in the following manner:—This ore we place in a solution of proto-chloride of iron, and heat it until it boils, by which time the cobalt, nickel, and manganese is in a state of solution. This solution we then draw off and precipitate the cobalt and nickel therein by adding to it sufficient sulphide of manganese or hydrated oxide of manganese to effect the purpose. We then draw off the supernatant liquor, which is a pure chloride of manganese solution such as is not obtainable from said ores by any other process whatever, and which solution we either crystalize for marketable purposes or evaporate at a moderate heat, whereby we effect two useful purposes, viz., we drive off the hydrochloric acid to a suitable vessel, and produce oxide of manganese as a residual product. The hydrochloric acid thus produced can be utilized for the manufacture of proto-chloride of iron, if nothing but manganiferous ore of cobalt and nickel are to be treated; but if nickel ore is also to be treated, we utilize the hydrochloric acid thus produced by heating it and using it as a bath for such nickel ore until all the nickel is dissolved by it and held in solution. This solution (containing other matters besides nickel) is then drawn off, and to it there is added sufficient sulphide or hydrated oxide of manganese to precipitate the nickel. After the nickel is precipitated the solution is again drawn off and evaporated at a low heat for the recovery of the hydrochloric acid, as is well understood, with which we make proto-chloride of iron, for the purpose of commencing again the whole process of treating manganiferous ores of cobalt and nickel, or with which to form a bath for the plain nickel ore when that ore is about to be treated. It will thus be seen that when the whole of our invention is used there is one continuous succession of operations without the loss of, but an insignificant percentage of the chemicals used therein. It is obvious, however, that where manganiferous ores of cobalt and nickel are alone to be treated, the first part of our invention may be advantageously used; and where nickel ore are alone to be treated, that the second part of our invention may be advantageously used, excepting only the last operation described of converting the hydrochloric acid into proto-chloride of iron, which would then not be done, but the acid used as a bath for the ore.

We are aware that proto-chloride of iron has been used before in the treatment of manganiferous ores of cobalt and nickel; but in that case there was twice as much used as was beneficial, and secondly, the ore and solution were boiled to dryness, and then heated in a furnace, whereas we do not boil to dryness nor do anything approaching to it, we simply boil and use only so much proto-chloride of iron as contains enough iron to equal in weight the combined weight of the nickel, cobalt, and manganese in the ore.

Having thus particularly described the nature of the said invention, and the manner of performing same, we would have it understood that what we believe to be new, and therefore claim as our improvements in the extraction of cobalt, nickel, and manganese from their ores, and of nickel from its ores, when such ores are found in a similar condition to those of New Caledonia, is—

- First—The succession of operations herein described and explained forming our complete process for treating the two kinds of ore, herein described.
- Second—The succession of operations forming our complete process for treating manganiferous ores of cobalt and nickel, substantially as herein described and explained.
- Third—The succession of operations forming our complete process for treating plain nickel ores, substantially as herein described and explained.
- Fourth—In process for treating either the plain nickel ores or the manganiferous cobalt and nickel ores of New Caledonia, precipitating either the nickel or the nickel cobalt in a chloride solution thereof by means of sulphide of manganese or hydrated oxide of manganese.

In witness whereof we, the said Henri Herrenschildt, Marmaduke Constable, Francis Lord, and David Wilson have hereunto set our hands and seals, this sixteenth day of July, one thousand eight hundred and eighty-four.

H. HERRENSCHMIDT.
MARMADUKE CONSTABLE.
FRAS. LORD.
DAVID WILSON.

This is the specification referred to in the Letters of Registration granted to Henri Herrenschildt, Marmaduke Constable, Francis Lord, and David Wilson, the thirteenth day of September, A.D. 1884.

AUGUSTUS LOPTUS.

REPORT.

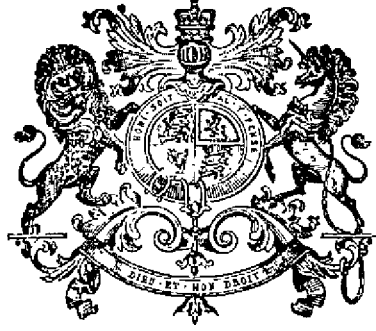
Sir,

Sydney, 25 July, 1884.

In the matter of the application of Mr. Herrenschildt and others for Letters of Registration for "Improvements in the extraction of cobalt, nickel, and manganese from their ores," which has been referred to us, we have examined the specification accompanying the same, and have now the honor to report that we see no objection to the issue of Letters of Registration as prayed for.

The Under Secretary of Justice.

We have, &c.,
J. SMITH.
A. LEIBIUS.



A.D. 1884, 13th September. No. 1497.

IMPROVEMENTS IN SELF-ADJUSTING MILL-STONE IRONS.

LETTERS OF REGISTRATION to George Summerton, for Improvements in Self-adjusting Mill-stone Irons.

[Registered on the 13th day of September, 1884, in pursuance of the Act 16 Vic. No. 24.]

BY HIS EXCELLENCY THE RIGHT HONORABLE SIR AUGUSTUS WILLIAM FREDERICK SPENCER LOFTUS (commonly called LORD AUGUSTUS LOFTUS), Knight Grand Cross of the Most Honorable Order of the Bath, a Member of Her Majesty's Most Honorable Privy Council, Governor and Commander-in-Chief of the Colony of New South Wales and its Dependencies.

TO ALL TO WHOM THESE PRESENTS SHALL COME, greeting :

WHEREAS GEORGE SUMMERTON, of San Francisco, in the United States of America, gentleman, hath by his Petition humbly represented to me that he is the author or designer of a certain invention or improvement in manufactures, that is to say, of an invention entitled "Improvements in Self-adjusting Mill-stone Irons," which is more particularly described in the specification and the sheet of drawings which are herunto annexed; and that he, the said Petitioner, hath deposited with the Honorable the Treasurer of the said Colony of New South Wales the sum of Twenty Pounds sterling, for defraying the expense of granting these Letters of Registration, as required by the Act of Council, sixteenth Victoria, number twenty-four; and hath humbly prayed that I would be pleased to grant Letters of Registration, whereby the exclusive enjoyment and advantage of the said invention or improvement might be secured to him for a period of fourteen years: And I, being willing to give encouragement to all inventions and improvements in the arts or manufactures which may be for the public good, and having received a report favourable to the prayer of the said Petition, from competent persons appointed by me to examine and consider the matters stated therein and to report thereon for my information, am pleased, with the advice of the Executive Council, and in exercise of the power and authority given to me by the said Act of Council, to grant, and do by these Letters of Registration grant unto the said George Summerton, his executors, administrators, and assigns, the exclusive enjoyment and advantage of the said invention or improvement, for and during the term of fourteen years from the date hereof; to have, hold, and exercise unto the said George Summerton, his executors, administrators, and assigns, the exclusive enjoyment and advantage thereof, for and during and unto the full end and term of fourteen years from the date of these presents next and immediately ensuing, and fully to be complete and ended: Provided always, that if the said George Summerton shall not, within three days after the granting of these Letters of Registration, register the same in the proper office in the Supreme Court, at Sydney, in the said Colony of New South Wales, then these Letters of Registration, and all advantages whatsoever hereby granted, shall cease and become void.

In witness whereof, I have hereunto set my sign manual, and have caused the present Letters of Registration to be sealed with the seal of the said Colony of New South Wales, at Government House, Sydney, in New South Wales, this thirteenth day of September, in the year of our Lord one thousand eight hundred and eighty-four.

[L.S.]

AUGUSTUS LOFTUS.

Improvements in Self-adjusting Mill-stone Irons.

SPECIFICATION of GEORGE SUMMERTON, of San Francisco, in the United States of America, gentleman, for an invention entitled "Improvements in Self-adjusting Mill-stone Irons."

My invention relates to certain improvements in mill-stone irons, and it consists in means by which the stationary or non-revolving stone is hung on self-adjusting irons, so that the face of the non-revolving stone may adjust itself to the face of the runner-stone, it being desirable that the face of the runner-stone should revolve in a plane parallel to the face of the non-revolving stone.

In this invention, the runner-stone may be made a fixture at will to driving-spindle, or may be hung upon loose irons in the usual method.

In the usual method of hanging mill-stones the stationary or non-revolving stone is a fixture, and the runner-stone is driven either with universal irons with bail and driver, or with stiff irons. When on loose irons the runner-stone has to be balanced on the irons and in motion, in order to get what is known as the standing and running balance, and the spindle has to be carefully trammed, that it may run at right angles to the face of the non-revolving stone.

When the runner-stone hangs upon stiff irons it is even more necessary carefully to trammel the spindle to the non-revolving stone.

Notwithstanding the greatest care in balancing, it is impossible to obtain a perfect balance of the runner; and, however carefully the spindle may be trammed, the strain from the power used in driving will spring the spindle and cause the stone to grind more on one side than the other. Thus, even if it were possible perfectly to balance the runner, the springing of the spindle would throw the stone out of tram and cause the material to be unevenly ground.

Again, if the spindle could be perfectly trammed, the defects in the balance of the runner would cause uneven grinding. Both of these difficulties are overcome by my invention, because, in whatever position the face of the runner may be, the non-revolving stone will immediately reciprocate.

Referring to the accompanying drawings,—

Fig. 1, sheet 1, is a vertical section taken through the stones and spindle.

Fig. 2 is a top view of the bottom irons with a portion broken away.

Fig. 3, sheet 2, is a vertical section taken at right angles with fig. 1.

Fig. 4 is a bottom view of the runner-iron or inque.

Figs. 5, 6, 7, are detail views of parts of the irons.

Fig. 8 shows an under-runner and the self-adjusting irons applied to the upper disc.

I have shown my invention applied to an upper-runner and a lower non-revolving stone. A is the upper and B the lower mill-stone. In carrying this invention into effect, I take a socketed centre casting or forging of iron or steel C, such as is commonly known as a "stiff inque," having preferably three radial arms, and of such material, shape, and size as is suitable for the runner, into which said stiff inque is permanently secured by means of bolts and cement. The upper end of the spindle D is fitted and locked to the said socketed centre casting by means of a stud W and nut Z, so that the runner will rotate with the spindle. The upper side of the washer X beneath the nut may be shaped as a saucer and serve as a feeder.

The lower stone B is cemented and fixed to a circular plate F, which fits into its lower surface as shown, and has an upwardly extending hollow cylindrical extension G, which projects upward into the hollow central portion of the stone.

Upon opposite sides of the part G are openings H, the upper sides of which form semi-circular caps, which fit upon similarly shaped trunnions I upon the hollow cylinder J. This cylinder has semi-circular openings K in its lower edges in radial lines, at right angles with the trunnions I, forming caps to rest upon trunnions L which project from the sides of the inner cylinder M. This cylinder M has four arms N projecting radially from its lower edge, and these are bolted to the hurst-timbers O to support the whole weight of the stone B.

There is a space between the inner cylinder M and the cylinder J, and also between J and the outer cylinder G, so that the stone, which is supported by means of the two sets of trunnions at right angles with each other, may have a motion about them to raise or lower its edges or skirt at any point, and thus adjust itself to the irregularities of motion of the upper stone.

The spindle D turns in a step at the lower end, and is supported, where it passes through the lower stone and the inner cylinder M, by babbitted boxes or followers P.

Three or more of these segmental boxes P are fitted into vertical channels formed by projections Q within the cylinder M, and upon the back in the centre of each is a spherical projection R. Behind each of these pieces P is a plate S having a depression corresponding with the projection R, and into which the latter fits, so that the interior segments may have a rocking adjustment about the spherical projections R, to allow them to fit the spindle D perfectly if it should run out of line by reason of the strain from the power used in driving, or from other cause.

Wedges T are driven in behind the plates S, and by these the segments P are kept to a bearing upon the spindle D.

Adjustable screws or stops U project upward from the arms N or the bed-timbers to limit the movements of the lower stone upon its trunnions.

A flexible apron, flange, or gasket V is fixed around the lower stone and presses against its periphery to prevent dust from falling down at that point. W is a screw passing through a disc or washer X into the top of the spindle D, and having a nut Z screwed down upon the top. The flanged edge of the disc rests upon the top of the inque C in the upper stone, and tends to prevent the stone from rising when a large amount of feed is passing beneath it.

Mill-stones are, in some instances, replaced by metal discs or artificial stones. It will be manifest that my invention will apply not only to mill-stones properly so called, but to any apparatus operating similarly or designed to supply their place, although, for the sake of brevity, I have only mentioned mill-stones.

I have hereinbefore described my invention as applied to mills in which the upper stone is the runner; but it must be obvious that it is equally applicable to those in which the under stone is the runner, whether it be fixed rigidly or with loose irons to the spindle. In

Improvements in Self-adjusting Mill-stone Irons.

In this case the irons are made large enough to encircle the exterior of the upper stone, there being two sets of irons with trunnions at right angles like the gimbals of the mariner's compass.

As under-runner mills are usually of comparatively small dimensions, this method of suspending the non-revolving stone can be applied without difficulty.

The same adjustment of the runner to the non-revolving stone may be made if the disc runs upon a horizontal axis or in any other position, as the adjustment is always a relative one between the stones or discs.

Having thus described my invention, what I claim as new and desire to secure by Letters of Registration, is—

1. In a grinding-mill, a self-adjusting, non-revolving stone or disc opposed to the runner, and means for holding said non-revolving stone or disc in proper relation to the runner, constructed to allow said stone or disc automatically to yield so that the grinding or working faces are parallel with each other, as herein described.
2. In a grinding-mill, the stone A having the central hub and shell or inque fixed within it, and the spindle D to which the inque is bolted fast.
3. In a grinding-mill, the non-revolving disc fixed to the circular-plate, the internal extensions with bearings at opposite sides, the interior cylinder with trunnions, and the intermediate cylinder with trunnions and bearings corresponding with those of the outer and inner cylinders.
4. The cylinder, with interior projections forming triangularly arranged vertical channels, the segmental bearings or followers, the plates and adjusting wedges, and the curved or spherical bearings interposed between the bearings and plates.
5. In a grinding-mill, the revolving disc rigidly fixed to the driving spindle, and the non-revolving disc supported so as to have a universal adjusting movement, the regulating screws U and the flexible gasket or apron V.
6. The means for adjusting and holding the spindle in position, consisting of the ball and socket or spherical joint applied to the boxes or followers, as herein described.

In witness whereof, I, the said George Summerton, have hereto set my hand and seal, this fifteenth day of July, one thousand eight hundred and eighty-four.

GEORGE SUMMERTON
(By his Attorney, EDWD. WATERS).

Witness—

W. S. BAYSTON, Patent Law Clerk, Melbourne.

This is the specification referred to in the annexed Letters of Registration granted to George Summerton, the thirteenth day of September, A.D. 1884.

AUGUSTUS LOFTUS.

REPORT.

Sir,

Referring to your B.C. memo. of 17th ultimo, forwarding a Petition from George Summerton for Letters of Registration for an invention entitled "Improvements in Self-adjusting Mill-stone Irons," we have the honor to inform you that, having examined the plan and specification accompanying the Petition, we are of opinion that Letters of Registration may be granted, in terms of the prayer of the Petitioner.

We have, &c.,

JOHN WHITTON.
E. O. MORIARTY.

The Under Secretary of Justice.

[Drawings—one sheet.]

Fig. 1.

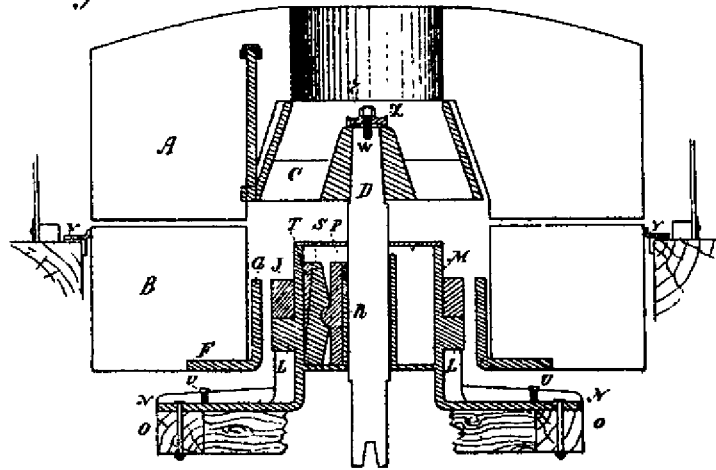


Fig. 3.

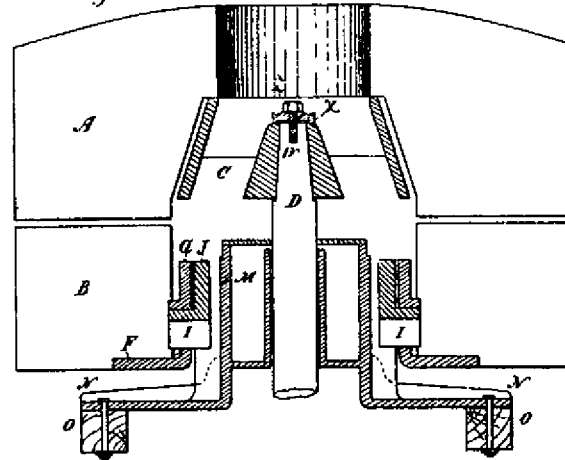


Fig. 4.

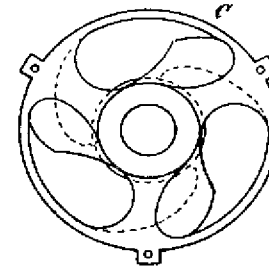


Fig. 2.

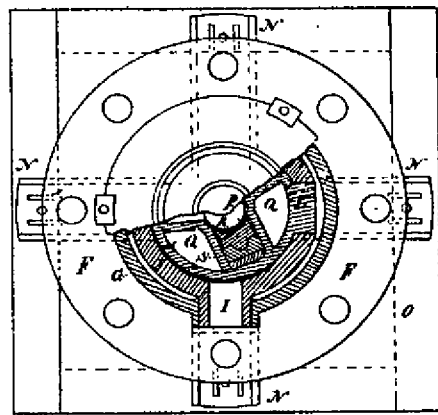


Fig. 7.

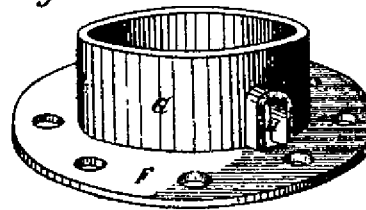


Fig. 5.

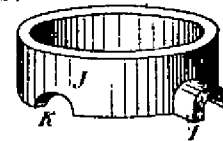


Fig. 6.

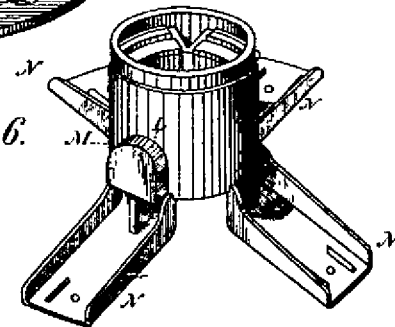
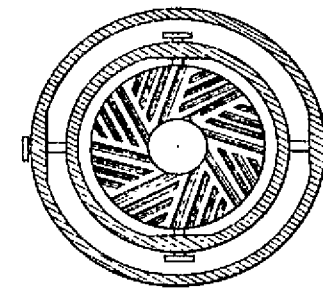


Fig. 8.



(Sig: 245) This is the Sheet of Drawings referred to in the annexed Letters of Registration, granted to George Summerton, the thirteenth day of September, A. D., 1884. Augustus Loftus.



A.D. 1884, 13th September. No. 1498.

IMPROVEMENTS IN INTERNALLY STOPPERED BOTTLES, AND IN THE
MANUFACTURE OF SUCH BOTTLES.

LETTERS OF REGISTRATION to Dan Rylands, for Improvements in internally
stoppered Bottles, and in the manufacture of such Bottles.

[Registered on the 15th day of September, 1884, in pursuance of the Act 16 Vic. No. 24.]

BY HIS EXCELLENCY THE RIGHT HONORABLE SIR AUGUSTUS WILLIAM FREDERICK SPENCER LOFTUS
(commonly called LORD AUGUSTUS LOFTUS), Knight Grand Cross of the Most Honorable Order of
the Bath, a Member of Her Majesty's Most Honorable Privy Council, Governor and Commander-in-
Chief of the Colony of New South Wales and its Dependencies.

TO ALL TO WHOM THESE PRESENTS SHALL COME, greeting :

WHEREAS DAN RYLANDS, of Stairfoot, Barnsley, in the county of York, in England, hath by his
Petition humbly represented to me that he is the author or designer of a certain invention or improvement in
manufactures, that is to say, of an invention entitled "Improvements in internally stoppered Bottles, and
in the manufacture of such Bottles," which is more particularly described in the specification and the sheet of
drawings which are hereunto annexed ; and that he, the said Petitioner, hath deposited with the Honorable
the Treasurer of the said Colony of New South Wales the sum of Twenty Pounds sterling, for defraying the
expense of granting these Letters of Registration, as required by the Act of Council, sixteenth Victoria,
number twenty-four ; and hath humbly prayed that I would be pleased to grant Letters of Registration,
whereby the exclusive enjoyment and advantage of the said invention or improvement might be secured
to him for a period of fourteen years : And I, being willing to give encouragement to all inventions
and improvements in the arts or manufactures which may be for the public good, and having received a
report favourable to the prayer of the said Petition, from competent persons appointed by me to examine
and consider the matters stated therein and to report thereon for my information, am pleased, with the
advice of the Executive Council, and in exercise of the power and authority given to me by the said Act of
Council, to grant, and do by these Letters of Registration grant unto the said Dan Rylands, his executors,
administrators, and assigns, the exclusive enjoyment and advantage of the said invention or improvement,
for and during the term of fourteen years from the date hereof ; to have, hold, and exercise unto the said
Dan Rylands, his executors, administrators, and assigns, the exclusive enjoyment and advantage thereof,
for and during and unto the full end and term of fourteen years from the date of these presents next and
immediately ensuing, and fully to be complete and ended : Provided always, that if the said Dan Rylands
shall not, within three days after the granting of these Letters of Registration, register the same in the
proper office in the Supreme Court, at Sydney, in the said Colony of New South Wales, then these Letters
of Registration, and all advantages whatsoever hereby granted, shall cease and become void.

In witness whereof, I have hereunto set my sign manual, and have caused the present Letters
of Registration to be sealed with the seal of the said Colony of New South Wales, at Govern-
ment House, Sydney, in New South Wales, this thirteenth day of September, in the year of
our Lord one thousand eight hundred and eighty-four.

[L.S.]

AUGUSTUS LOFTUS.

Improvements in internally stoppered bottles, &c.

SPECIFICATION of DAN RYLANDS, of Stairfoot, Barnsley, in the county of York, in England, for
 "Improvements in internally stoppered bottles, and in the manufacture of such bottles."

IN the specification of Letters Patent, No. 13,438, dated 11th December, 1882, granted to Hiram Codd and myself, for improvements in bottles for containing aerated liquids, and in the manufacture of such bottles, a process is described for punching a hole through the bottle neck after the bottle has been taken from the mould. My present invention is applicable to the boring or punching of a hole in the bottle neck before the bottle leaves the mould, and by this means more uniformity of position of the hole is secured. And the hole can also be punched in any special part of the bottle neck, as for instance, in any indentation, with much more satisfactory results than is possible after the bottle has been removed from the mould. In order to accomplish this, I affix to the mould-plate, which bears the mould, an iron arm, which carries a spur or pinion wheel, to which is affixed an eccentric circular plate; I also attach to this iron band another smaller spur or pinion wheel, to which is fastened a pointed steel punch.

To the eccentric or cam-plate, which is attached to the large spur wheel, I attach a foot treadle, and this foot treadle is so arranged that, with the pressure of the blower's foot, it causes the larger pinion wheel and cam to revolve. This sets in motion the small pinion wheel to which the punch is attached, and by the large cam-plate working in a suitable groove, a quick backward and forward motion is given to the punch. The mode of application will then be as follows:—The bottle-blower, after blowing the bottle up in the mould, presses with his foot upon the treadle, which rotates the large pinion wheel and sends the point of the punch (which works through a suitably formed hole in bottle mould) through the neck of the bottle, thus perforating a hole in such neck. It must, however, be understood that I do not limit myself to the exact mechanical details hereinbefore described, the important feature of my present invention being the punching of holes in bottle necks before the bottle has been withdrawn from the mould. As a further improvement on my previous letters patent hereinbefore referred to, I use a glass stem for the valve, which stem has a mushroom shaped head at one end and two small shoulders at the other, for receiving the India-rubber washer. I also attach around this glass stem a small spring, so that it is always kept in right position. The valve arrangement may, where preferred, be applied to the bottle by forming a hole (during the process of pressing the marble) through the centre of the marble, and fitting the valve through the hole, where such plan may be found more suitable than punching the hole in the neck of the bottle. In order that the nature of my invention, and the manner of performing the same, may be more clearly understood, I will now proceed by reference to the accompanying drawings, to further describe and ascertain the manner in which the same is to be carried into effect.

DESCRIPTION OF DRAWINGS.

Fig. 1 is a front elevation, with the bottle mould removed. Fig. 2 is a plan showing the bottle mould attached, and fig. 3 is a transverse section on the line Y Y of fig. 2 of my improved machine for boring or punching a hole in the bottle neck before the bottle leaves the mould. Fig. 1a is a modification of the above. Fig. 4 is a side elevation, and fig. 5 a front elevation of a screw nipple. Fig. 6 is a side elevation, and fig. 7 an end elevation of my improved glass stem, applicable to a valve placed in a bottle neck. Figs. 8 and 9 are respectively elevation and section of a spring (preferably made of India-rubber), but which may be made of wire or any other suitable material. Figs. 8a and 9a are respectively elevation and section of an India-rubber washer, used in the formation of a valve in bottle neck. Fig. 10 is a side elevation of presser, pointer, and pycers, with a washer; the aforesaid presser, pointer, and pycers are tools which I use for forcing both washer and India-rubber spring on to glass stem. Fig. 11 is a sectional elevation of the neck of a bottle with my improved glass stem and spring, and shows the method of using the pycers for forcing the washer on to the neck of the glass stem. Fig. 12 is a sectional elevation of a bottle neck, showing my improved stem and spring fitted therein, and hermetically closed. Fig. 12a is a side view, showing hole formed in the bottle neck. Fig. 12b is a broken sectional plan through the line x x of fig. 12. Fig. 13 is a sectional elevation of a marble mould, showing the arrangement for forming a hole through the marble, when such marble is made of glass, during the process of pressing the same. The marble may, however, be made of India-rubber or any other suitable substance. Figs. 14 and 15 are respectively elevation and plan of the marble thus pressed. Fig. 16 is a sectional elevation within bottle neck, and fig. 17 is a cross-section (without bottle neck) of my improved stem and spring fitted through the hole in marble, and hermetically closed. Referring to figs. 1 to 5, A is the arm, made with slot holes a a, through which pass the bolts B B, which secure the arm A to the mould-plate C; the mould-plate C is fastened to the resting-plate P by the screws or bolts p' p'. By means of the slot holes a a the arm A is lowered or raised to suit the drilling of a hole in any part of the bottle neck. The spur wheel E is keyed on to the shaft e, which shaft e has bearings f f in the arm A. Between the bearings f f, and keyed on the shaft e, an eccentric plate or cam G is placed, having a groove g around it. This groove g may be made to have any suitable throw.

The spur wheel E gears into the smaller spur or pinion wheel H. This smaller spur or pinion wheel H is made of such a width on the face that when the throw is given to the spindle h, the smaller spur or pinion wheel H does not run out of gear with the spur wheel E. The smaller spur or pinion wheel H is keyed on to the steel spindle h, which has its bearings i i in the arm A. To the end of the steel spindle h a punch or drill d is attached. This punch or drill d may be made solid with the spindle h, or may be made separate, and screwed therein. On the steel spindle h is keyed a reel I, having a groove j around it; between the reel I and cam G a reciprocating lever J is placed, which works on the centre pin k, and has at one end a runner l running in the groove g of the cam G, and at the other end a runner m, running in the groove j of the reel I. On the shaft e is keyed the spur wheel L, gearing with the rack N. The rack N has a treadle n formed at the top thereof. The treadle n and rack N are held up by means of the spring b, which is made of such strength that whenever the bottle-blower's foot is off the treadle n this spring b will force the rack and treadle back to the position shown at fig. 1. The back of the rack N slides in the guides O. The guides O are carried by the plate o, which is attached to the resting-plate P by the bolts p p. The nipple Q, figs. 4 and 5, has projections q q; it is screwed into the neck of the bottle mould in the place where it is required to punch or drill the hole in the bottle neck. The punch d of the steel spindle h works through this nipple Q, and into the neck of the bottle, as shown at fig. 3. The mode of application will be as follows:—The bottle-blower, after having blown the bottle
 up

Improvements in internally stoppered bottles, &c.

up in the bottle mould D, presses with his foot on the treadle *n*; this forces the rack N down, which being geared with the wheel L, and the wheel L being keyed on to the shaft *e*, which is also attached to the cam G, the whole thus revolves, and the wheel E gearing with the smaller spur or pinion H, which pinion is keyed on to the spindle *h*, having the reel I keyed thereon, also revolves; the runner *l* working in the groove *g* of the cam G, works backwards and forwards the reciprocating lever J, and by means of the runner *m* working in the groove *j* of the reel I, the spindle *h* with the punch *d* not only revolves but also travels to the extent of the throw of the cam G, so that by means of the aforesaid pressure of the blower's foot on the treadle *n*, the punch or drill *d* (which works through the nipple Q) has its point sent through the neck of the bottle, thus perforating, punching, or boring a hole in such neck.

Referring to fig. 1a, which is a modification of the hereinbefore described machine for drilling or punching a hole in the bottle neck before said bottle has left the mould; the foot lever or treadle *n* is carried on the centre pin *n'*, on which it works. This centre pin is screwed into the boss *n''* of the arm A. At the end of the foot lever *n* is a spiral spring *n'*, fastened to the foot lever *n* at *n''*, and to the arm A at *n'''*. This spiral spring is made of such a strength that whenever the bottle-blower's foot is off the treadle, or foot lever *n*, this foot lever will return to the position shown at fig. 1a. In this foot lever *n*, a slot hole *r'* is made, through which passes the bolt or pin *r''*, attaching the connecting rod *r'''* thereto. This connecting rod *r'''* is attached to the spur wheel E by means of the bolt or pin *r''*. The spur wheel E is weighted at the side *e'*, so that the connecting rod *r'''* never gets on dead centre. The mode of application will be as follows:—The bottle-blower, after having blown the bottle up in the bottle mould D, presses with his foot on the foot lever or treadle *n*, which, by means of the connecting rod *r'''*, turns the spur wheel E, and thus sets in motion the rest of the apparatus, which is precisely the same as that hereinbefore described with reference to figs. 1 to 5. After the hole has been perforated, bored, or punched in the bottle neck, the blower takes his foot off the treadle *n*, when the spring *n'* draws the treadle *n* back to the position shown at fig. 1a, when the punch or drill *d* will be withdrawn from the mould. Referring to figs. 6 to 9 the glass stem *z* has a mushroom shaped head R at one end, and has two small shoulders S and T at the other. These shoulders S and T form the recess or neck U for the reception of the India-rubber washer W. Around this glass stem *z*, and close to the head R, is a spring V, figs. 8 and 9, which spring I prefer to be made of India-rubber, but it may be made of wire or any other suitable material. Referring to figs. 10, 11, and 12, 12a and 12b, the spring V (figs. 8 and 9) is picked up by the pointer *s*, and is pressed on the portion *w* of the pliers *t*. The presser *r* and the pointer *s* are then withdrawn, leaving the spring V on the portion *w* of the pliers *t*. My improved glass stem *z* is then placed in the portion *w* of the pliers *t*, and the pliers forced open, thus placing the spring V near the head R of the stem *z*. A washer W (figs. 8a and 9a) is then picked up by the pointer *s* and forced on to the part *w* of the pliers *t* by means of the presser *r*. The presser *r* and pointer *s* are then withdrawn, leaving the washer W on the portion *w* of the pliers *t*. Then the stem *z*, which has had the spring placed close to its head R, is placed through the perforated hole *x* of the neck of the bottle, with the head R and spring V on the outside, and the shoulders S and T forming the recess U within; at the same time the portion *w* of the pliers *t* is placed on to the shoulder T and neck U, the pliers *t* are then forced open, thus placing the washer W in the neck U of the stem *z*. The bottle will then be as shown at fig. 12. When a bottle thus made has been filled with aerated water, it is only necessary to press on the head R of the stem *z*, thus forcing the India-rubber washer W clear of the hole *x* in the bottle neck, and allowing the gas to escape through the hole *x* and out of the recesses *x'* *x'* (figs. 12a and 12b). Referring to figs. 13 to 17, in order to form a hole through the marble 2 during the process of pressing, the marble mould is made in two halves, the bottom portion 3 having one-half of the sphere 6 (which sphere is made the shape the marble is required to be), the top portion 5 having the other half of the sphere in it; the stems 4, 4 pass through the top portion 5, and extend to the bottom of the sphere 6. The stems 4, 4 have projections 8, 8, which form the small recesses *x'* *x'* in the marble 2. The stems 4, 4 are fastened to the iron ring or plate 7, to which are also fastened the holding down clips 9, 9. At the bottom of the holding down clips 9, 9 is a screw 10 attached loosely to the clips 9, 9 by means of the collars 12 and 13. The screw 10 works in the hand-wheel 14. The hand-wheel 14 is supported by the bridge 15, and worked in the usual way. The mode of application will be as follows:—Before putting the molten glass into the middle of the mould to be pressed, the wheel 14 is turned to position shown on the drawing, thus bringing the holding down clips 9, 9 to position also shown on drawing (fig. 13). Molten glass is then poured in the centre of the marble mould, and by the pressure of the plunger 16 the molten glass is forced into the spheres 6, 6, thus forming the marbles 2, 2 (figs. 14 and 15). The plunger 16 is then withdrawn in the usual way, and by the turning of the wheel 14 the screw 10 is so actuated as to lift the holding down clips 9, 9 sufficiently high for the stems 4, 4 to clear the mould, which may then be opened in the usual way, and the marbles 2, 2 withdrawn from the spheres 6, 6. Figs. 14 to 17 show the application of the marble with valve complete. The two indents *x'* *x'* on the top of the marble are to allow the gas to escape when the stem *z* is pressed, as described in relation to figs. 12, 12a, and 12b. I would here remark that I do not confine myself to glass only for the material of which I would make the perforated marbles, as they may be made of India-rubber or any other suitable material. If made of India-rubber, the necessity of using the spring V and washer W would be obviated. It will also be well understood that although my present invention (as herein described with reference to figs. 1 to 12b) is shown in combination with a bottle closed internally by means of a marble as shown, that I do not limit its application to this special style of internally stoppered bottle, but that it may, where preferred, be applied to the necks of bottles fitted with any other suitable form or shape of internal stopper.

Having now particularly described and ascertained the nature of the said invention, and the mode of carrying the same into effect, I would have it understood that in my present invention for "Improvements in internally stoppered bottles, and in the manufacture of such bottles," I do not claim *per se* the punching of holes in bottle necks, or the fitting of such holes with valves, but what I do claim is:—

- 1—The arrangements for forming, perforating, or punching holes in the necks of internally stoppered bottles before such bottles have been withdrawn from the mould, substantially as set forth and described with reference to figs. 1 to 5 (and including fig. 1a) of the accompanying drawings, or any mere modification thereof.

Improvements in internally stoppered bottles, &c.

- 2—The improved valve for fitting such hole, substantially as set forth and described with reference to figs. 6 to 9a, and also to figs. 11 and 12 of the accompanying drawings, or any mere modification thereof.
- 3—The improved arrangements for adapting valves to marbles for internally stoppered bottles, substantially as shown and described with reference to figs. 13 to 17 of the accompanying drawings, or any mere modification thereof.

In witness whereof, I, the said Dan Rylands, have hereunto set my hand and seal, this 4th day of June, 1884.

DAN RYLANDS.

This is the specification referred to in the annexed Letters of Registration granted to Dan Rylands, the thirteenth day of September, A.D. 1884.

AUGUSTUS LOFTUS.

REPORT.

Sir,

The application of Mr. Dan Rylands for Letters of Registration for an invention entitled "Improvements in internally stoppered bottles, and in the manufacture of such bottles" having been referred to us, we have examined the specification and plan accompanying the same, and have now the honor to report that we see no objection to the issue of Letters of Registration as applied for.

We have, &c.,

ARCH. C. FRASER.
THOS. RICHARDS.

The Under Secretary of Justice.

[Drawings—one sheet.]

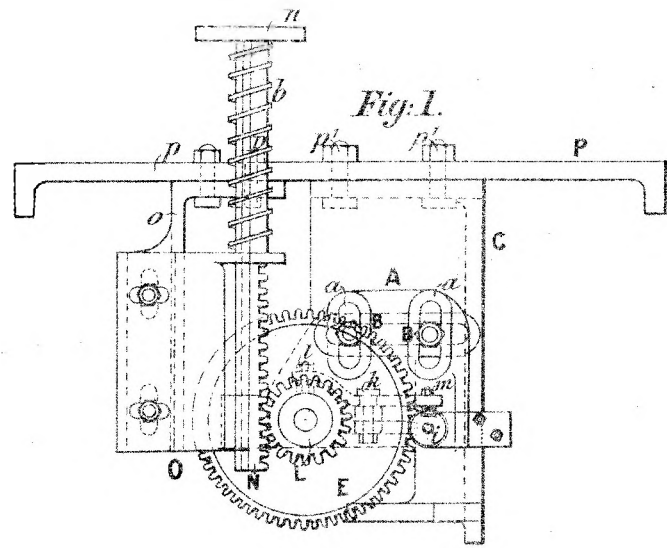


Fig. 2.

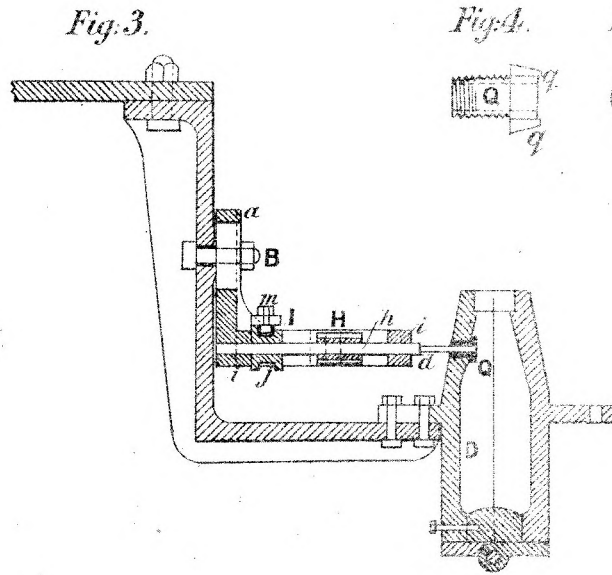
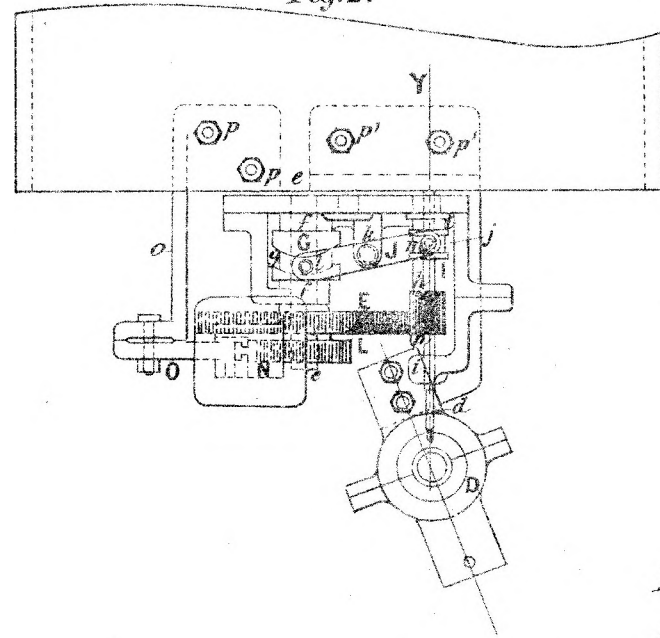


Fig. 4.

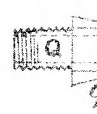


Fig. 5.

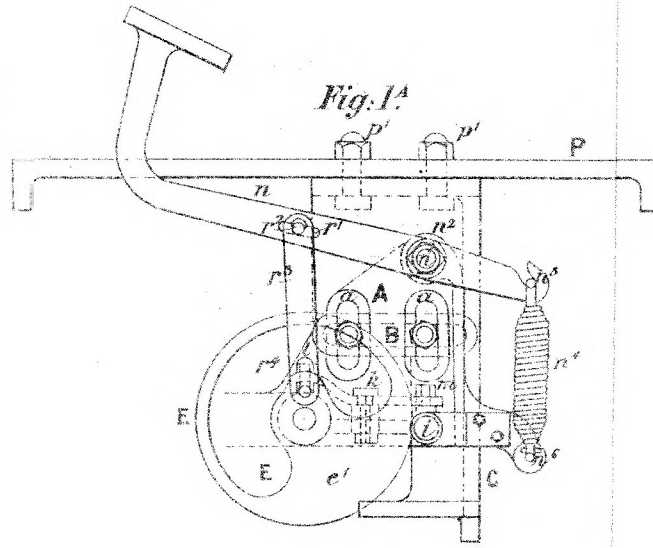


Fig. 13.

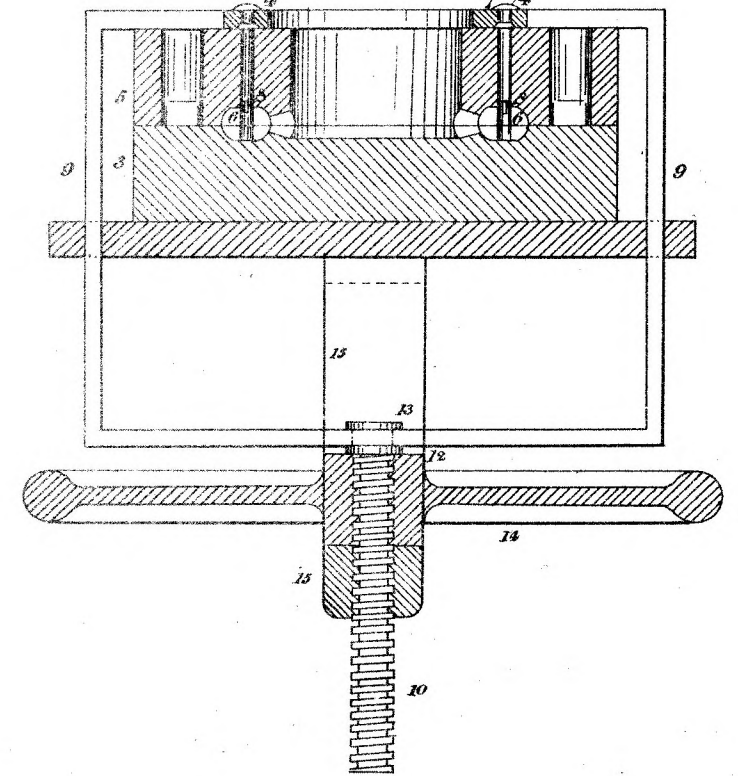
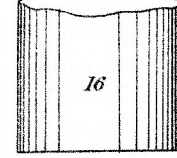


Fig. 10.

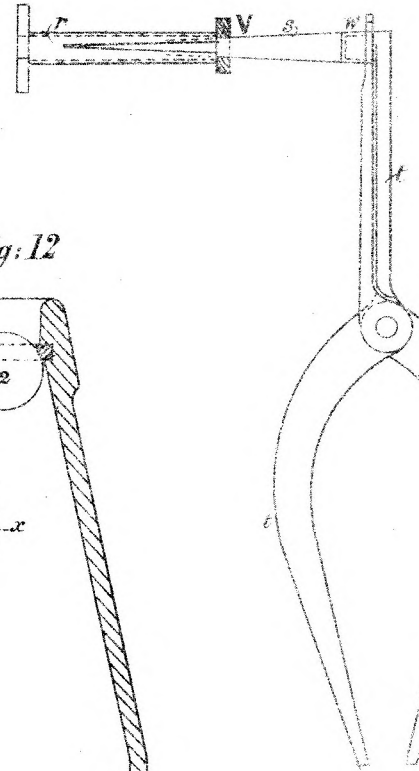


Fig. 11.

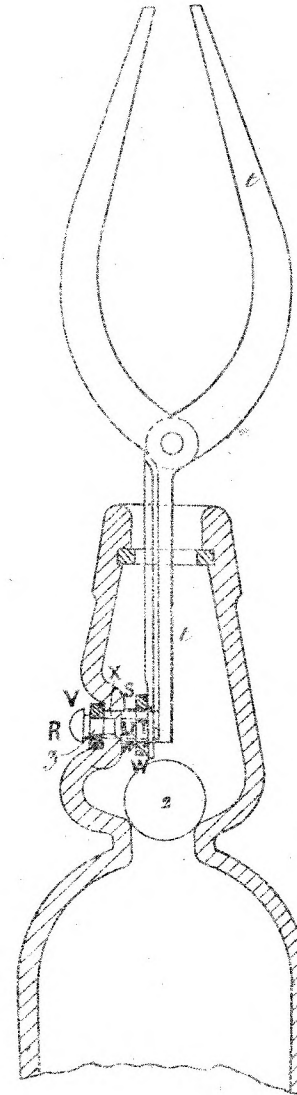


Fig. 14.



Fig. 15.



Fig. 6.



Fig. 7.



Fig. 8.



Fig. 9.



Fig. 8^a

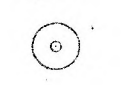


Fig. 9^a



Fig. 12^a

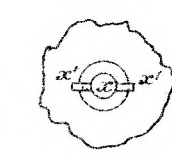


Fig. 12^b

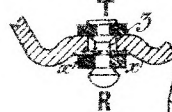


Fig. 12.

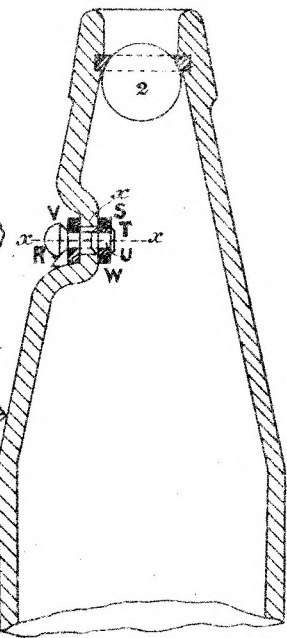


Fig. 16.

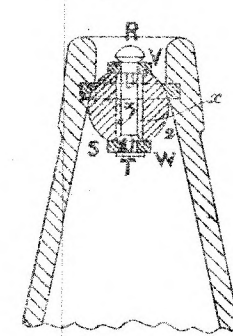
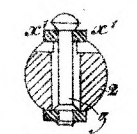


Fig. 17.



This is the Sheet of Drawings referred to in the annexed Letters of Registration granted to Dan Ryland, the thirteenth day of September, A. D. 1884.

Augustus Loftus.



A.D. 1884, 13th September. No. 1499.

IMPROVEMENTS IN LAMPS, &c.

LETTERS OF REGISTRATION to John Fuller Shallis and Thomas Cooper John Thomas, for Improvements in Lamps or Apparatus for lighting Railway Carriages, and for other purposes.

[Registered on the 15th day of September, 1884, in pursuance of the Act 16 Vic. No. 24.]

BY HIS EXCELLENCY THE RIGHT HONORABLE SIR AUGUSTUS WILLIAM FREDERICK SPENCER LOFTUS, (commonly called LORD AUGUSTUS LOFTUS), Knight Grand Cross of the Most Honorable Order of the Bath, a Member of Her Majesty's Most Honorable Privy Council, Governor and Commander-in-Chief of the Colony of New South Wales and its Dependencies.

TO ALL TO WHOM THESE PRESENTS SHALL COME, greeting :

WHEREAS JOHN FULLER SHALLIS and THOMAS COOPER JOHN THOMAS, both of the Minorities, in the City of London, England, engineers, have by their Petition humbly represented to me that they are the authors or designers of a certain invention or improvement in manufactures, that is to say, of an invention entitled "Improvements in Lamps or Apparatus for lighting Railway Carriages, and for other purposes," which is more particularly described in the specification marked A, and the two sheets of drawings marked B and C, respectively, which are herewith annexed ; and that they, the said Petitioners, have deposited with the Honorable the Treasurer of the said Colony of New South Wales the sum of Twenty Pounds sterling, for defraying the expense of granting these Letters of Registration, as required by the Act of Council, sixteenth Victoria, number twenty-four ; and have humbly prayed that I would be pleased to grant Letters of Registration, whereby the exclusive enjoyment and advantage of the said invention or improvement might be secured to them for a period of fourteen years : And I, being willing to give encouragement to all inventions and improvements in the arts or manufactures which may be for the public good, and having received a report favourable to the prayer of the said Petition, from competent persons appointed by me to examine and consider the matters stated therein and to report thereon for my information, am pleased, with the advice of the Executive Council, and in exercise of the power and authority given to me by the said Act of Council, to grant, and do by these Letters of Registration grant unto the said John Fuller Shallis and Thomas Cooper John Thomas, their executors, administrators, and assigns, the exclusive enjoyment and advantage of the said invention or improvement for and during the term of fourteen years from the date hereof ; to have, hold, and exercise unto the said John Fuller Shallis and Thomas Cooper John Thomas, their executors, administrators and assigns, the exclusive enjoyment and advantage thereof for and during and until the full end and term of fourteen years from the date of these presents next and immediately ensuing, and fully to be complete and ended : Provided always, that if the said John Fuller Shallis and Thomas Cooper John Thomas shall not, within three days after the granting of these Letters of Registration, register the same in the proper office in the Supreme Court, at Sydney, in the said Colony of New South Wales, then these Letters of Registration, and all advantages whatsoever hereby granted, shall cease and become void.

In witness whereof, I have herewith set my sign manual, and have caused the present Letters of Registration to be sealed with the seal of the said Colony of New South Wales, at Government House, Sydney, in New South Wales, this thirteenth day of September, in the year of our Lord one thousand eight hundred and eighty-four.

[L.S.]

AUGUSTUS LOFTUS.

Improvements in Lamps or Apparatus for lighting Railway Carriages.

A.

SPECIFICATION of JOHN FULLER SHALLIS and THOMAS COOPER JOHN THOMAS, both of the Minorities, in the City of London, England, engineers, for an invention entitled "Improvements in Lamps or Apparatus for lighting Railway Carriages, and for other purposes."

THIS invention has for its object improvements in lamps or apparatus for lighting railway carriages, and for other purposes.

In lamps, according to our invention, the oil or spirit is contained in an annular reservoir or receptacle, surrounding, or partly surrounding, a reflecting chamber or annular reflector, above which is a combustion chamber, having below it a transparent or translucent diaphragm or closure to exclude draught. The said combustion chamber is provided with holes to admit air for supporting combustion; also, this combustion chamber has a metal chimney, and the reflecting chamber below the transparent or translucent diaphragm is, or may be, provided with holes to admit of ventilation and allow the escape of heat. One arrangement of the reflecting chamber is in the form of a truncated cone, with its axis vertical; but it may be parabolic or otherwise shaped in vertical section, and in cross-section it may have a polygonal or other figure. The light is produced at one or more burners, arranged in a horizontal or an inclined position over the reflecting chamber, the burner or burners being set above the level of the oil or spirit, and protruding into the combustion chamber. The case and cover of the lamp are so arranged as to produce an efficient ventilation to keep the reservoir cool, and to carry off the vapour of any spirit that may escape or be spilt.

The transparent or translucent diaphragm below the combustion chamber may be in some part of the reflecting chamber, or between the two chambers. A bowl of clear or ground or opal glass, which may or may not contain liquid, may be used; or a lens or lenses, or a prism or prisms, to direct or disperse the light, may be employed in place of or in conjunction with the transparent diaphragm; also, lamps according to our invention, as above described, may be modified so as to use gas instead of oil or spirit. We make lenses, according to our invention, for directing or dispersing light from lamps of the improved kind above described of glass, coated or covered with opal; and such lenses may also be used in connection with lighting apparatus of other descriptions, including apparatus for lighting with gas.

In the accompanying drawings—

Figure 1 is a vertical section of one of our improved lamps.

Figure 2 is an elevation, showing the oil or spirit containing reservoir and reflecting chamber, as seen when lifted out of the lamp casing.

Figure 3 is a half plan of the same.

Figure 4 is a vertical section of the combustion chamber; and

Figure 5 is a sectional plan of the said chamber.

Figure 6 is a vertical elevation of part of a lamp body and top that may be used in place of the one shown in figure 1.

a is an annular reservoir containing the oil or spirit for supplying the burner, and surrounding a reflecting chamber b , above which is a combustion chamber c , having below it a transparent diaphragm d to exclude draught. c' is a metallic chimney. ee are holes in the chamber c to admit air for supporting combustion, &c. The reflecting chamber is also provided with holes b' to admit of ventilation and allow of the escape of heated air; and, in the arrangement shown, is in the form of a truncated cone with its axis vertical; but (as already stated) it may be parabolic or otherwise shaped in vertical section; and in cross-section it may have a polygonal or other figure. f is the burner, which in this case is shown as arranged in a horizontal position over the reflecting chamber; but, instead of being horizontal, the burner (or burners) may, as already stated, be inclined to the horizontal. The burner protrudes into the combustion chamber c , as shown. g is the outer casing of the lamp, in which the parts just described are carried or suspended, as represented in figure 1. It is provided with holes g^1 and g^2 in its upper part for ventilation, and is formed double, as shown, to prevent draught. h is a packing for preventing admission of air when the upper portion of the case is closed on the lower. i is the cover. A slightly different form of lamp-top and cover is shown in figure 6. k (figure 1) are holes to admit air for keeping the reservoir cool, and to carry off the vapour of any spirit that may escape or be spilt. l is a screw for feeding the wick when the upper part of the case is opened, but which may also be operated from below by pushing a key through the tube m (which passes through the reflector and reservoir) on to a square end of the said screw, as shown more clearly in figure 2. Liquid combustible is fed to the reservoir through a hole usually covered by the screwed cap n provided with a tube n' . o is a spring catch for keeping the upper part of the case closed upon the lower.

When the illuminating medium is gas, the reservoir a is not required, and the burner f is replaced by one or more suitable gas burners. The connection to the gas-mains may be made in any convenient manner. When the lamp, as arranged for gas, is required to be easily replacable, a plug on the lamp, dropping into a conical socket on the frame or carriage, forms a convenient connection to the gas-main.

Figure 4 shows a modification of the manner in which the transparent diaphragm d is secured below the combustion chamber. The inside of the combustion chamber and the surface of the reflecting chamber are, in the example illustrated, enamelled; and the said reflecting chamber, combustion chamber, and oil reservoir, may be lifted bodily out of the lower casing of the lamp when required. The lower part or mouth of the reflecting chamber may, if desired, be provided with a lens for directing or dispersing the light. When such is used, it is usually advantageous to make it in the improved manner hereinbefore described—that is to say, of glass, coated or covered with opal. The glass is a lens of suitable form, according to the direction in which the rays of light are to be dispersed, and the outer surface of the glass lens has accurately fitted over it a layer or cover of opal of uniform thickness.

Sometimes we provide a chamber or chambers (conveniently it may be an annular chamber) applied to the inner casing above the reservoir, and this chamber (or where more than one are employed, then each of them) communicates with the reservoir by a suitable pipe or pipes or passages extending downward nearly to the bottom of the reservoir; also, we provide for the ready escape outward of oil or spirit from the said chamber or chambers. The object of this arrangement is to allow of ready escape for oil or spirit in the event of the lamp being accidentally upset, thus obviating the danger that would attend the escape of the oil or spirit through the wick-tube.

In

Improvements in Lamps or Apparatus for lighting Railway Carriages.

In lieu of applying the overflow chamber or chambers to the inner casing, the same may be applied on top of the reservoir.

In figure 7, *s* represents the chamber to receive oil or spirit that may overflow or be spilt.

This chamber, in the arrangement illustrated, almost surrounds the inner casing *g*.

This chamber *s* (or where more than one are employed, then each of them) communicates with the reservoir *l* by a suitable pipe or pipes or passages *t* extending downwards nearly to the bottom of the reservoir *l*. Also, we provide for the ready escape outward of oil or spirit from the said chamber *s* or chambers by means of holes *s'* formed through the outer wall *s⁺* of the chamber *s*.

Figure 8 shows the overflow chamber in horizontal section in the line A B of figure 7.

In figures 9 and 10 is illustrated a modified arrangement.

Figure 9 is an elevation showing the oil or spirit reservoir and the overflow chambers. In this arrangement, four separate chambers *ss* are provided in lieu of the annular chamber before described. *s' s'* are holes for escape of oil or spirit from the chambers *s*.

Figure 10 is a horizontal section taken in the line C D of figure 9.

The chambers *s* communicate with the reservoir by tubes *t t*, which extend some distance into the reservoir, as described with reference to figures 7 and 8.

Figure 11 shows in vertical section the arrangement of the oil reservoir and inner casing, where, in lieu of applying the overflow chamber to the inner casing, the same is applied on top of the oil reservoir; and figure 12 is a plan of the reservoir and overflow chamber. *s* is the annular overflow chamber applied to the top of the reservoir *l*. The chamber *s* has overflow holes *s' s'* formed through its top, and it communicates with the reservoir *l* by means of tubes *t t*.

Having now described the nature of the said invention, and the manner in which it is to be, or may be, carried into practical effect, we would have it understood that what we consider to be novel and original, and therefore claim, is:—

1. In a lamp or lighting apparatus, the combination of a combustion chamber, a burner or burners projecting through and into the same, a transparent or translucent diaphragm closing the bottom of the said chamber, and a reflecting chamber or annular reflector arranged below the said diaphragm, substantially as above described.
2. In a lamp or lighting apparatus, wherein oil or spirit is consumed, the combination of a combustion chamber, one or more burners projecting into such chamber horizontally or angularly, a metal chimney, a transparent or translucent diaphragm closing the bottom of the said combustion chamber, a reflecting chamber or annular reflector arranged below the combustion chamber, and an oil or spirit reservoir or receptacle surrounding or partly surrounding the said reflecting chamber or annular reflector, and in communication with the burner or burners, substantially as above described.
3. The improved lamp or lighting apparatus shown in and described with reference to figures 1, 2, and 3 of the drawings.
4. In a lamp or lighting apparatus, the use of a lens, coated or covered with opal, for directing or dispersing the light, substantially as described.
5. Providing for escape of oil or spirit from the reservoir in the event of the lamp being upset or tilted, substantially as, and by the means hereinabove described, with reference respectively to figures 7 and 8, figures 9 and 10, and figures 11 and 12 of the drawings hereinunto annexed.

In witness whereof, we, the said John Fuller Shallis and Thomas Cooper John Thomas, have hereinunto set our hands and seals, this thirtieth day of May, 1884.

JOHN FULLER SHALLIS.

THOMAS COOPER JOHN THOMAS.

This is the specification marked A referred to in the annexed Letters of Registration granted to John Fuller Shallis and Thomas Cooper John Thomas, the thirteenth day of September, A.D. 1884.

AUGUSTUS LOFTUS.

REPORT.

Sir,

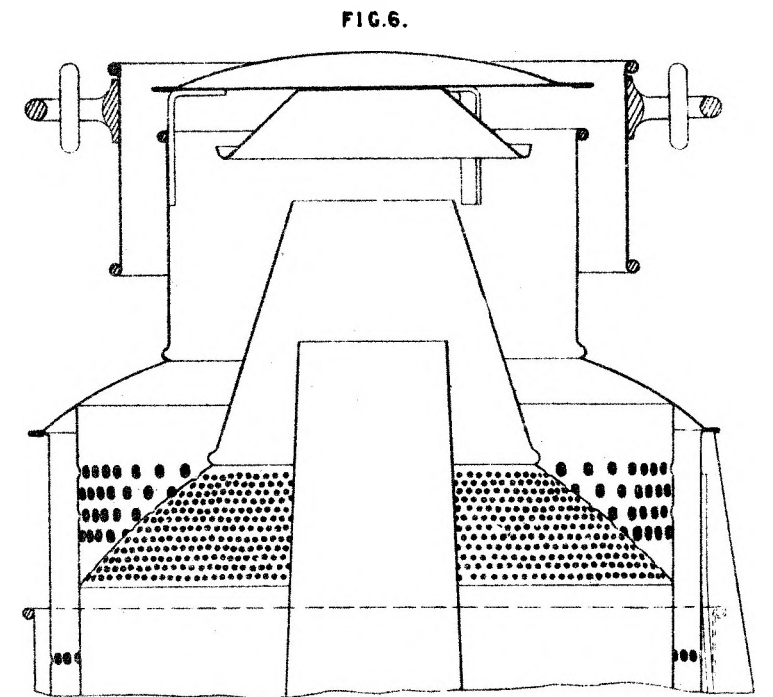
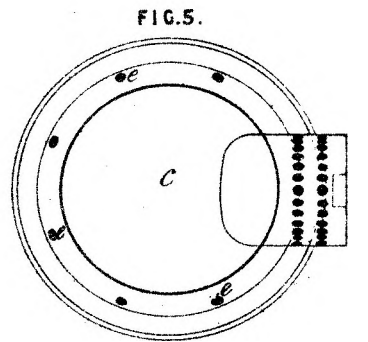
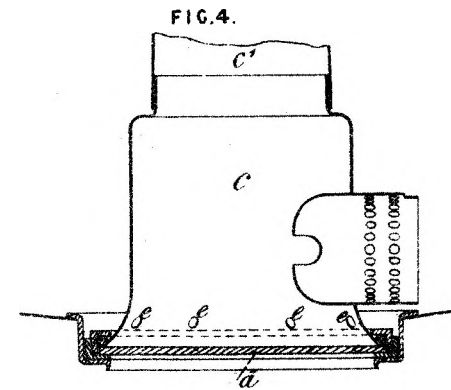
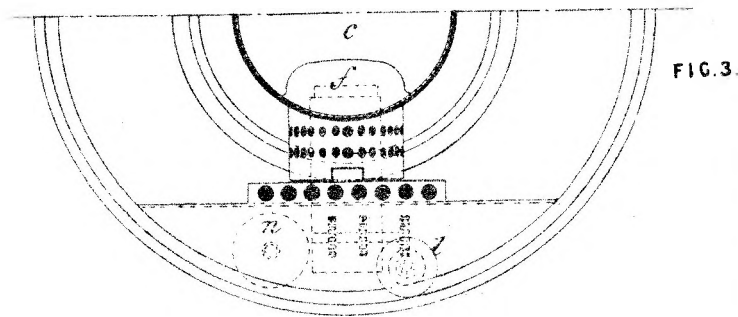
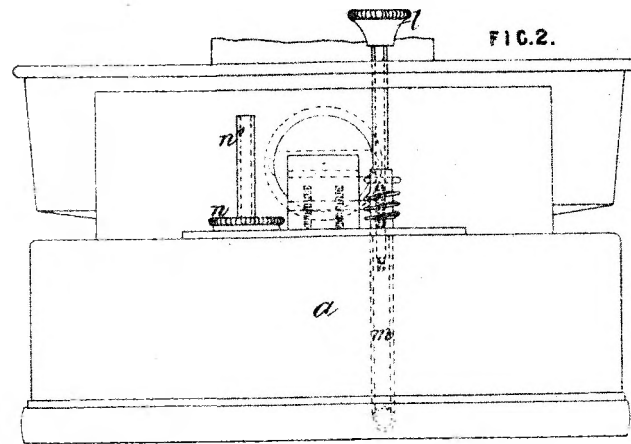
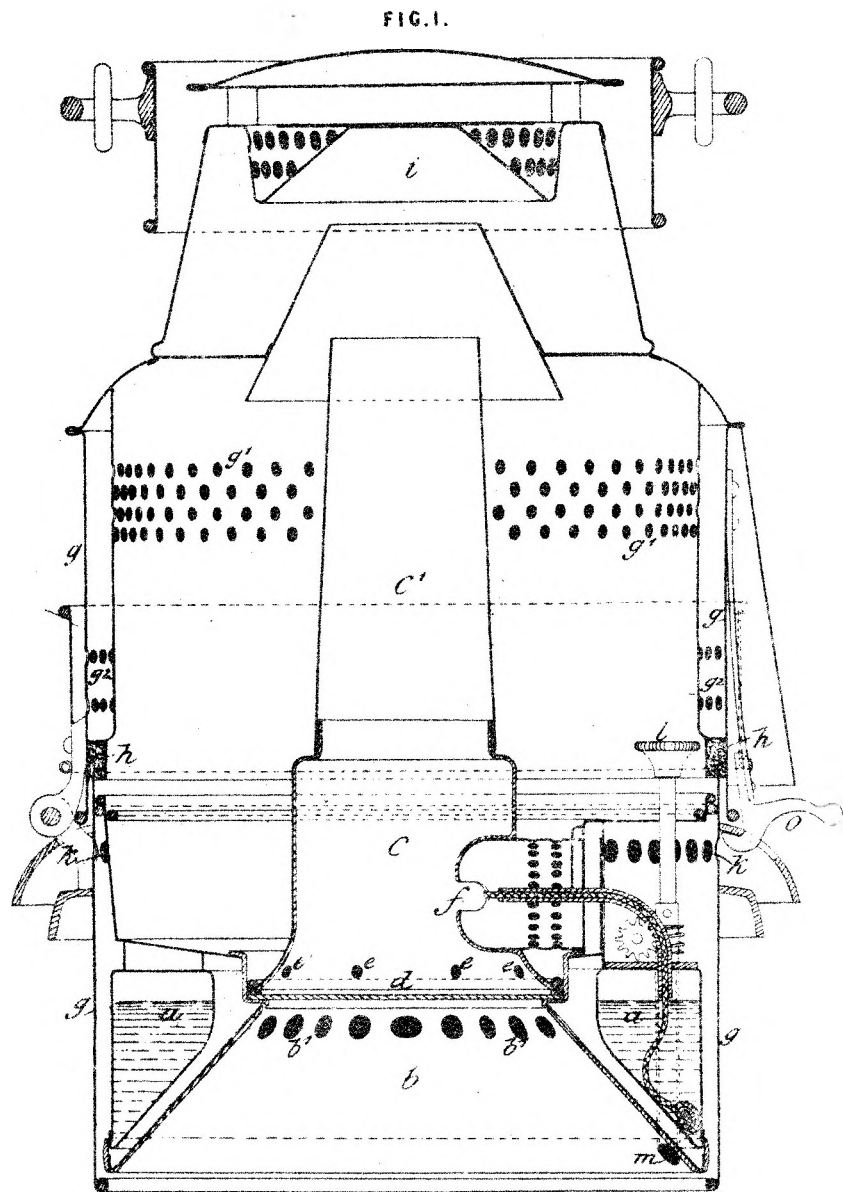
Sydney, 1 August, 1884.

In reference to your B.C. of the 17th ultimo, forwarding a Petition from Messrs. Shallis and Thomas for Letters of Registration for an invention entitled "Improvements in Lamps or Apparatus for lighting Railway Carriages, and for other purposes," we have the honor to inform you that, having examined the plans and specification accompanying the Petition, we are of opinion that Letters of Registration may be issued, in terms of the prayer of the Petitioners.

We have, &c.,
JOHN WHITTON,
E. O. MORIARTY.

The Under Secretary of Justice.

B



(Sig: 245~)

John Fuller Shallis
Thomas Cooper John Thomas

This is the Sheet of Drawings marked B, referred to in the annexed Letters of Registration, granted to John Fuller Shallis and Thomas Cooper John Thomas, the thirteenth day of September, A. D., 1884.

Augustus Loftus.

C

FIG. 7.

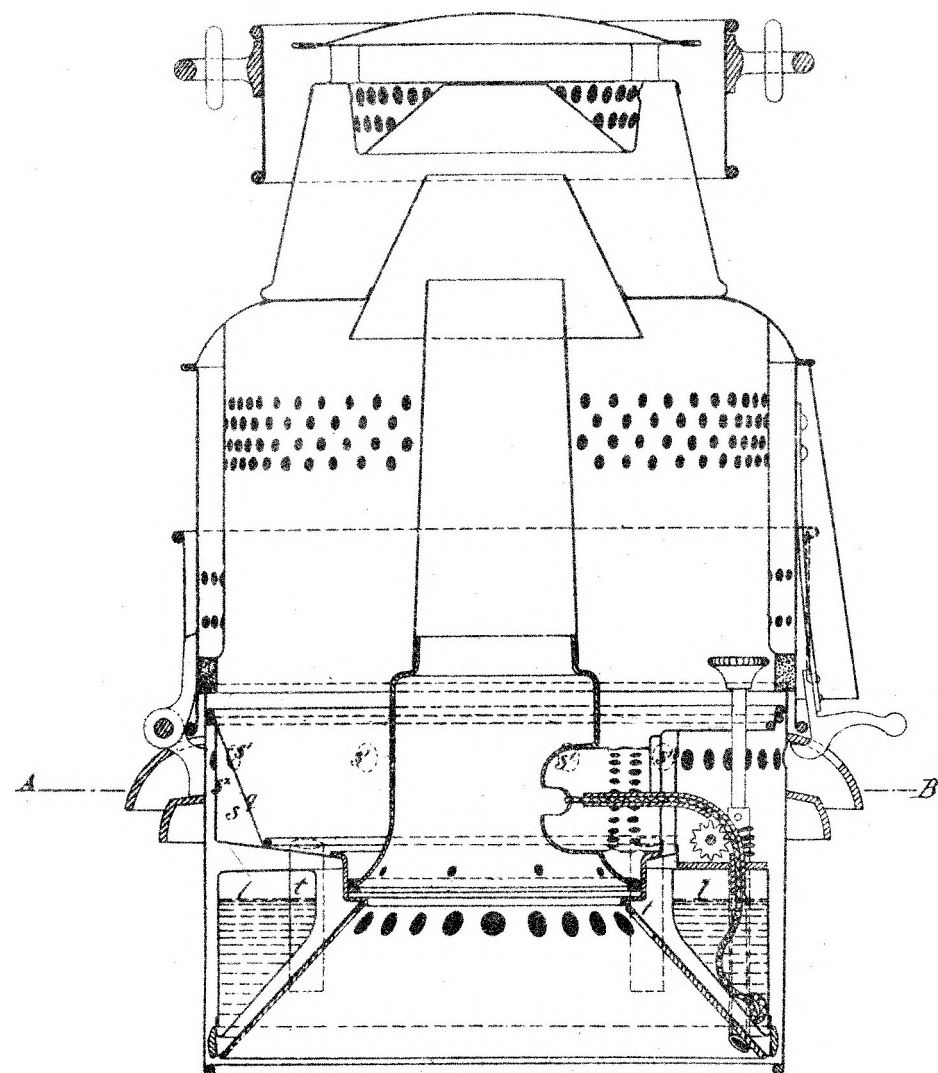


FIG. 9.

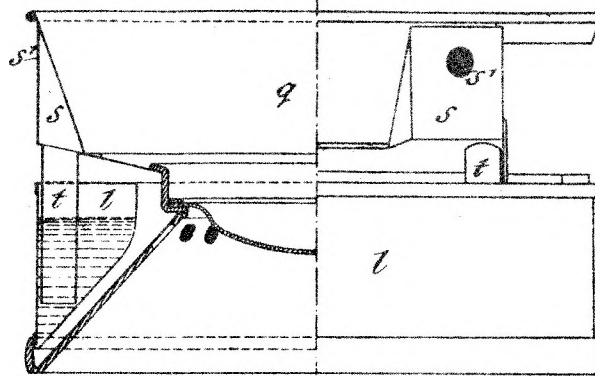


FIG. 11.

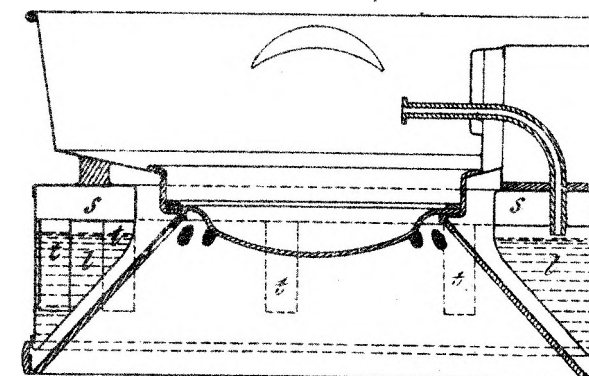


FIG. 8.

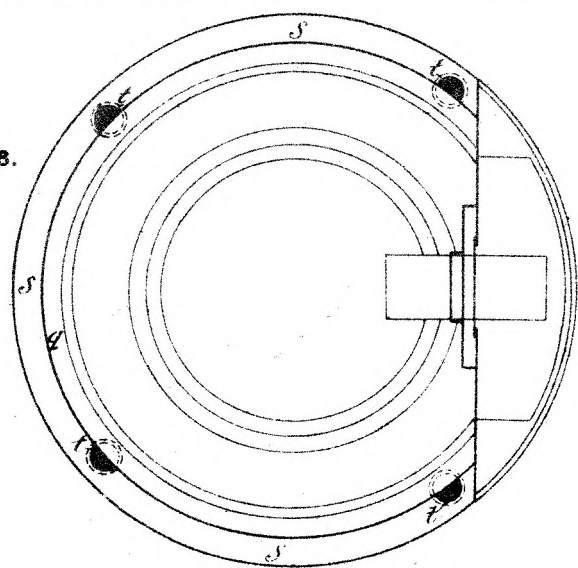


FIG. 10.

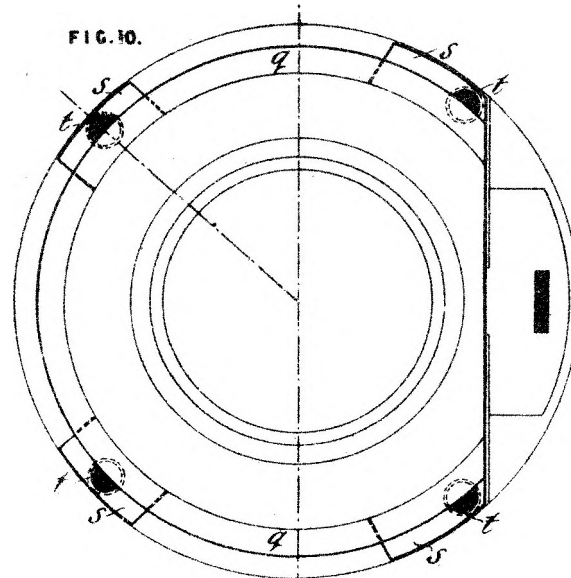
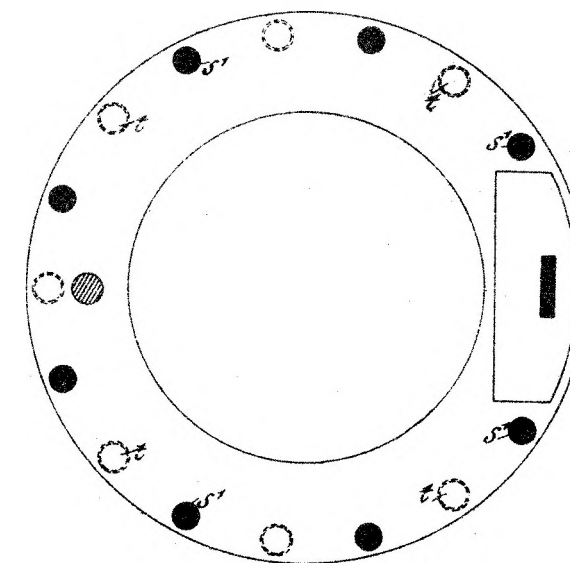


FIG. 12.



(Sig: 245~)

*This is the Sheet of Drawings marked C, referred to in the annexed
 Letters of Registration, granted to John Fuller Shallis and Thomas
 Cooper John Thomas, the thirteenth day of September, A. D. 1884.
 Augustus Loftus.*

*John Fuller Shallis
 Thomas Cooper John Thomas*



A.D. 1884, 13th September. No. 1500.

AN IMPROVED MACHINE FOR MAKING CLIPS FOR FASTENING WIRES
TO THEIR SUPPORTS.

LETTERS OF REGISTRATION to James Milne, for an Improved Machine for
making Clips for fastening wires to their supports.

[Registered on the 15th day of September, 1884, in pursuance of the Act 16 Vic. No. 24.]

BY HIS EXCELLENCY THE RIGHT HONORABLE SIR AUGUSTUS WILLIAM FREDERICK SPENCER LOFTUS
(commonly called LORD AUGUSTUS LOFTUS), Knight Grand Cross of the Most Honorable Order of
the Bath, a Member of Her Majesty's Most Honorable Privy Council, Governor and Commander-in-
Chief of the Colony of New South Wales and its Dependencies.

TO ALL TO WHOM THESE PRESENTS SHALL COME, greeting :

WHEREAS JAMES MILNE, of No. 162A, Sussex-street, Sydney, in the Colony of New South
Wales, coppersmith, hath by his Petition humbly represented to me that he is the author or designer of a
certain invention or improvement in manufactures, that is to say, of an invention entitled "An Improved
Machine for making Clips for fastening wires to their supports," which is more particularly described in
the specification and the sheet of drawings which are hereunto annexed; and that he, the said Petitioner,
hath deposited with the Honorable the Treasurer of the said Colony of New South Wales the sum of Twenty
Pounds sterling for defraying the expense of granting these Letters of Registration, as required by the Act of
Council, sixteenth Victoria, number twenty-four; and hath humbly prayed that I would be pleased to grant
Letters of Registration whereby the exclusive enjoyment and advantage of the said invention or improvement
might be secured to him for a period of fourteen years: And I, being willing to give encouragement to
all inventions and improvements in the arts or manufactures which may be for the public good, and having
received a report favourable to the prayer of the said Petition from competent persons appointed by me
to examine and consider the matters stated therein and to report thereon for my information, am pleased,
with the advice of the Executive Council, and in exercise of the power and authority given to me by the
said Act of Council, to grant, and do by these Letters of Registration grant unto the said James Milne,
his executors, administrators, and assigns, the exclusive enjoyment and advantage of the said invention or
improvement, for and during the term of fourteen years from the date hereof; to have, hold, and exercise
unto the said James Milne, his executors, administrators, and assigns, the exclusive enjoyment and
advantage thereof for and during and unto the full end and term of fourteen years from the date of these
presents next and immediately ensuing, and fully to be complete and ended: Provided always, that if the
said James Milne shall not, within three days after the granting of these Letters of Registration, register the
same in the proper office in the Supreme Court, at Sydney, in the said Colony of New South Wales, then
these Letters of Registration, and all advantages whatsoever hereby granted, shall cease and become void.

In witness whereof, I have hereunto set my sign manual, and have caused the present Letters of
Registration to be sealed with the seal of the said Colony of New South Wales, at Govern-
ment House, Sydney, in New South Wales, this thirteenth day of September, in the year of
our Lord one thousand eight hundred and eighty-four.

[L.S.]

AUGUSTUS LOFTUS.

An Improved Machine for making Clips for fastening wires to their supports.

SPECIFICATION of JAMES MILNE, of No. 162A, Sussex-street, Sydney, in the Colony of New South Wales, coppersmith, for an invention entitled "An Improved Machine for making Clips for fastening wires to their supports."

THE clips for fastening wires to their supports which my improved machine makes, are especially useful for attaching telegraph wires to their insulators; but they may also be used for attaching other wires to supports—for instance, to affix fencing wires to the fence posts. This clip is made of one piece of wire, and consists of a semicircular hook or band, whose point is bent sideways into another, but much smaller, hook, or, in other words, there is at one end of a piece of wire a short bend or hook, from which, in a plane at right angles to the plane of such short bend, a semicircular bend commences, and the other end is continued beyond the semicircle any desired length.

The improved machine for making said clip, automatically feeds the wire from the coil into a twisting device, which makes the smaller bend or hook, further feeds the hooked end into a grip or clamp on the end of a crank-like device, which pulls the wire round itself and makes the semicircular bend, and lastly feeds the wire with the two bends a further distance, so that a shearing device cuts the completed clip off with the desired length of straight end.

But, in order that this invention may be clearly understood, I will now describe the same with reference to the drawings hereto attached, in which figure 1 shows one of the clips; figure 2 is a front elevation of my improved machine for making such clips; figure 3 a side elevation; figure 4 back elevation; and figure 5 a plan of the same; and figure 6 is a front elevation, on a smaller scale, of the machine, with a coil of wire in position.

The clip consists of a small hook A, a larger bend or semicircle A¹, and an extended tail A². In use, the hook A is passed over or hooked on to the wire to be supported, the larger bend or semicircle A² passed round the back or over the top of the support, say an insulator or a fence post, and the tail A² twisted once or oftener round the said wire, and which twist or twists may be loose or as tight as desirable. In making these clips, the hook A is made of sufficient size to take in the gauge of wire to be supported, and the bend or semicircle A¹ is of the same diameter as that portion of the insulator which it encircles when used for fastening a telegraph wire, and of a diameter equal to the thickness of the support when used for other purposes, and the tail A² in all cases is sufficiently long that it may be grasped and twisted around the wire to be supported.

Above the improved machine for making said clips is a holding frame B, on which a coil of wire B¹ is fixed, and the end B² led to the machine. Referring to the machine itself, C is a feeding roller, C¹ tension roller, C² spring, C³ set-screw, C⁴ ratchet-wheel, C⁵ spring-pawl, C⁶ lever, C⁷ connecting-rod, C⁸ push-lever on spindle C⁹, C¹⁰ cam, C¹¹ back lever, also on spindle C⁹, C¹² helical spring, D is guide, D¹ shear-plate, D² bell-crank, D³ connecting-rod, D⁴ link or lever, D⁵ cam, D⁶ flat spring under link D⁴, E is further guide, E¹ its cover, E² the twisting device, being a disc, having upon its centre-pin E³ and projection E³, over both of which may be also fitted a cover, E⁴ is spindle, E⁵ strap, E⁶ pulley, E⁷ lever, centred at E⁴, E⁸ is cam, and E⁹ a coiled spring, F is the bending device, for simplicity called a "crank," F¹ a grip or clamp on its end, and F² a toggle-joint within its body, F³ connecting-link, F⁴ crank-pin, F⁵ toothed-pinion, F⁶ toothed-wheel on pin or spindle F⁷, F⁸ is crank-pin, F⁹ connecting-rod, F¹⁰ link or lever, F¹¹ cam, F¹² coiled spring within pinion F⁵, F¹³ is adjustable bracket, F¹⁴ its fastening bolt in slot F¹¹, G is the main shaft, on which may be pulleys, toothed-wheels, or other means for actuating same, and G¹ are its bearings, H is the frame and sole-plate.

To make a clip, the end B² of the wire is led between feeding-roller C and roller C¹, the tension of which is regulated by set screw C³ and spring C², and allowed to be fed down so far that the shear-plate D¹ cuts off any ragged or waste end, and starts the making of the clips from that point or moment. The cam C¹⁰ working around, pushes against lever C⁶, and motion is communicated by connecting-rod C⁷, lever C⁸, and spring-pawl C⁵, to the ratchet-wheel C⁴, and roller C, which feeds down the wire through guide E, into the twisting device E¹, between centre pin E³, and projection E³, and at this moment by the action of the cam E⁸, pushing against lever E⁷, which pulls the strap E⁵, a partial or half revolution is given to said device E¹, which partial revolution turns the end of the wire right round the centre-pin E³, and forms the small bend or hook A. The coiled spring E⁹ keeps the lever E⁷ hard up against the cam E⁸, and also returns to and retains the device E¹ in its normal position ready for the end of the wire to enter between pin E³ and projection E³. The spring C¹² ensures the contact of the end of lever C⁶ on the face of cam C¹⁰; and after the bend or hook A is made, the shape of such cam imparts, by means of the mechanical parts beforementioned, a second movement to the roller C, and thus feeds the wire with its hooked end, so that said hook clears the twisting device E¹, which returns to its normal position, and said hook then enters between the grip or clamp F¹. Now the cam F¹⁰ comes into play, and acting upon rod F⁹, partially revolves wheel F⁶ and pinion F⁵, and the crank-pin F⁴ pulls the link F³, and the toggle-joint F², and closes the clamp F¹, and gives it a tight grip upon the bent end A of the wire, and at the same time the revolving of the wheel and the crank F⁴ pulls the wire through the guides D and E, and bends it round the curved end of such crank, or, in other words, makes the bend or semicircle A¹. A third movement by the same means as before described is imparted to roller C, and the wire is fed down the required distance to give the desired length of tail A² to the clip, when the projection of cam D⁵ acting on link D⁴, moves bell-crank D², and gives a sudden pull to the shear-plate D¹, which cuts off the completed clip, which falls to the ground or into a receptacle provided, while at the same time the coiled-spring F¹² returns the crank F⁴, pinion F⁵, wheel F⁶, and rod F⁹, to their normal position, or as near to it as the face of the rod, link, or lever F³, hard up on the face of cam F¹⁰, will allow. After the cutting off movement, the flat spring D⁶ returns the shear-plate D¹ and its gear to their normal position, so that the wire may again be threaded through it at the first movement of the roller C, upon the commencement of making a clip as before described, and the operations beforementioned are all repeated automatically, and the machine keeps on making clips until the revolutions of shaft G are stopped.

It is to be noticed that by adjusting the bracket F¹³ on its centre, the crank F⁴ and grip F¹ are raised or lowered as the case may be, and thus the length of the short end of the clip or the end which has the short hook or bend, is increased or diminished respectively.

Having

An Improved Machine for making Clips for fastening wires to their supports.

Having thus particularly described and ascertained the nature of the said invention, and the manner in which the same is to be performed, I would have it understood that I do not confine myself to any particular manner or means by or in which the same may be carried into effect, nor to any particular size or material of which any of its parts may be constructed, but what I believe to be novel; and of my invention and desire to secure by Letters Patent, is:—

First—The combination and arrangement of feeding-roller C, roller C¹, ratchet-wheel C¹, and pawl C² (with or without spring C², and set-screw C²), with the lever C³, rod C³, lever C³, cam C³, lever C⁴, and spring C⁴, substantially as herein described and explained, and as illustrated in the drawings.

Second—The combination and arrangement of guide D, shear-plate D¹, bell-crank D², connecting-rod D³, link D⁴, cam D⁵, and spring D⁶, substantially as herein described and explained, and as illustrated in the drawings.

Third—The combination and arrangement of twisting device E, having centre-pin E², and projection E³, with means for intermittently giving it a partial revolution forwards from and backwards to its normal position, substantially as herein described and explained, and as illustrated in the drawings.

Fourth—The combination and arrangement of bending device F, having grip F¹, with toggle-joint F², and link F³, to crank pin F⁴, with means for intermittently giving such device a partial revolution, and allow it to recover its normal position, substantially as herein described and explained, and as illustrated in the drawings.

In witness whereof, I, the said James Milne, have hereto set my hand and seal, this twenty-third day of July, one thousand eight hundred and eighty-four.

Witness,—

FRED WALSH,
Manager, E. Waters' Patent Office, Sydney.

JAMES MILNE.

This is the specification referred to in the annexed Letters of Registration granted to James Milne, the thirteenth day of September, A.D. 1884.

AUGUSTUS LOFTUS.

REPORT.

Sir,

We do ourselves the honor to report, in reply to your blank cover of the 24th ultimo, No. 8,021, transmitting Mr. James Milne's Petition for the registration of "an Improved Machine for making Clips for fastening wires to their supports," that we are of opinion the prayer of the Petitioner may be granted, in terms of his specification, drawings, and claim.

Sydney, 4 August, 1884.
We have, &c.,
E. C. CRACKNELL.
GOTHER K. MANN.

The Under Secretary of Justice.

[Drawings—one sheet.]

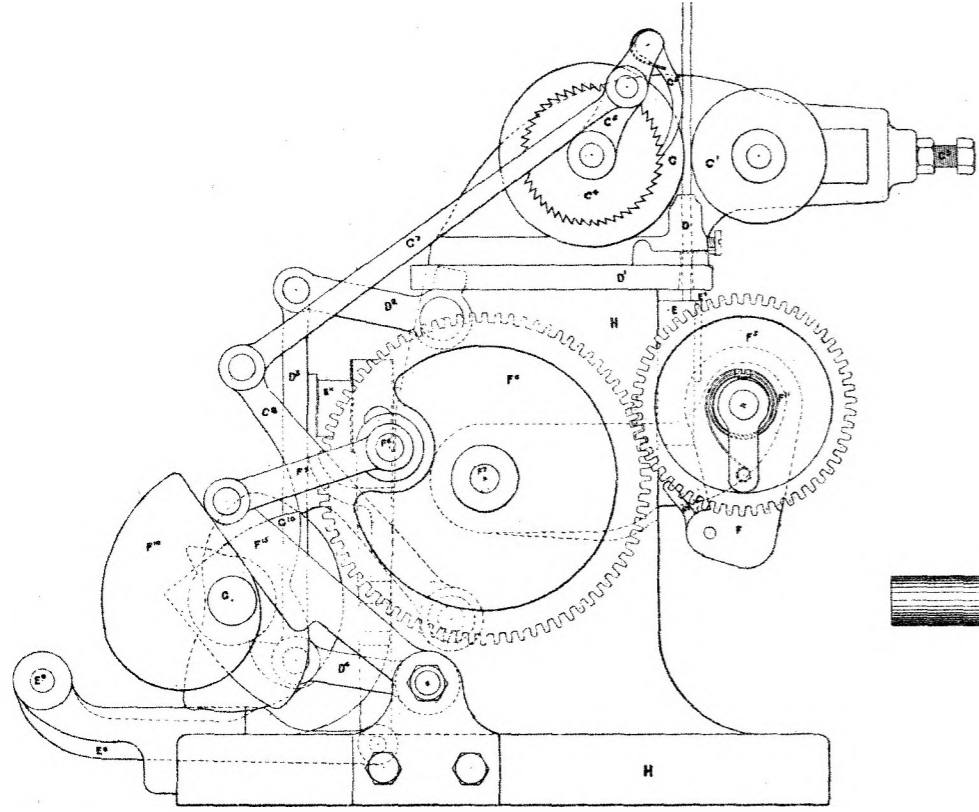


FIG. II

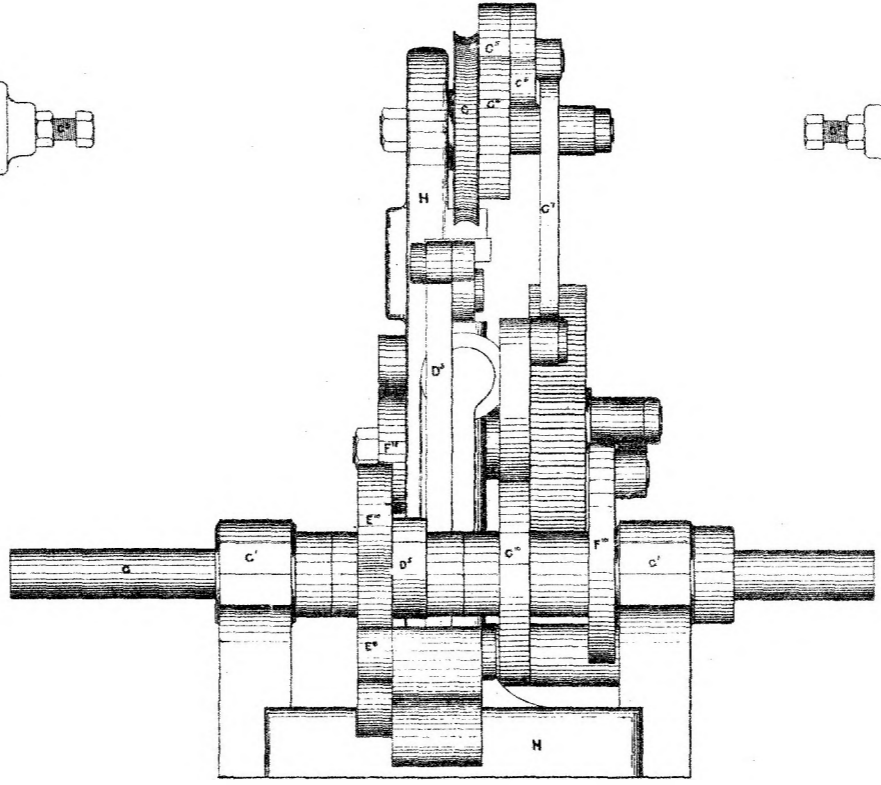


FIG. III

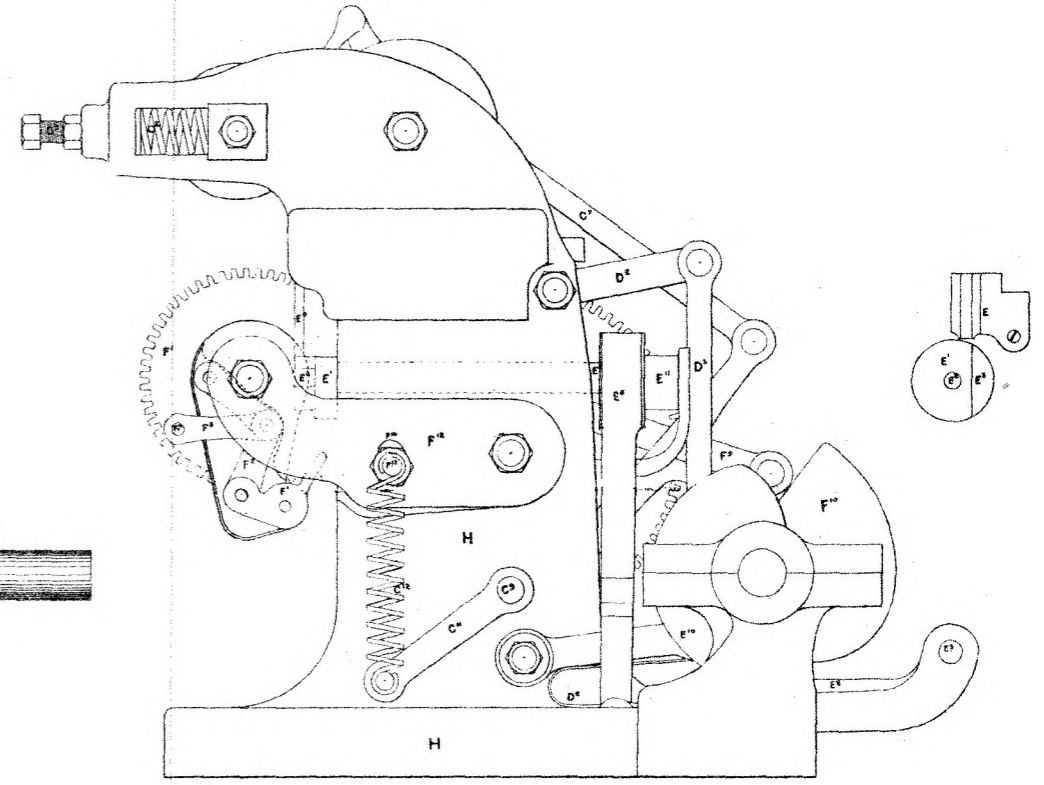


FIG. IV

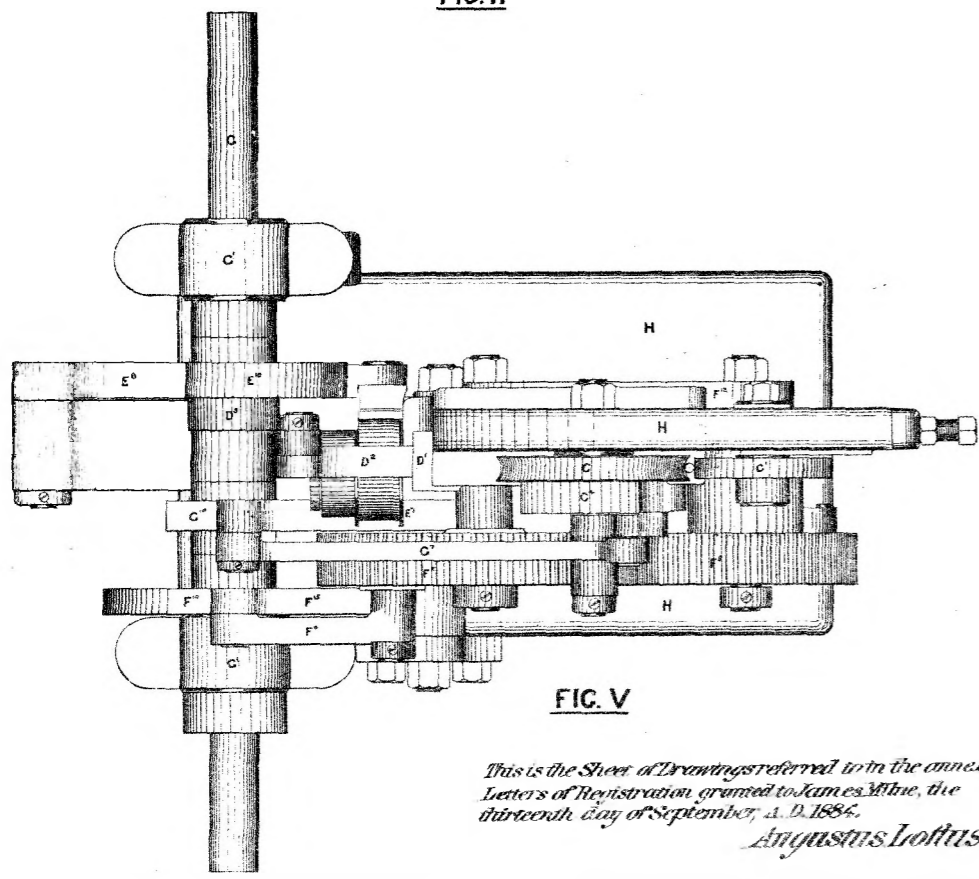


FIG. V

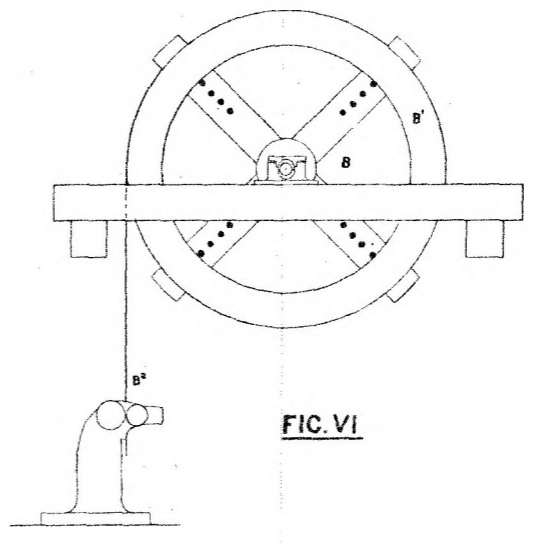


FIG. VI

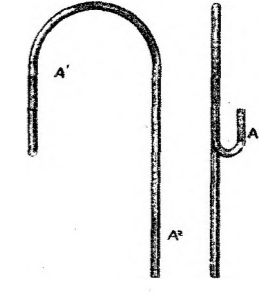


FIG. I

*This is the Sheet of Drawings referred to in the annexed
 Letters of Registration granted to James Alfie, the
 thirteenth day of September, A. D. 1886.
 Augustus Loftus.*



A.D. 1884, 15th September. No. 1501.

IMPROVEMENTS IN HARVESTING MACHINES.

LETTERS OF REGISTRATION to James Morrow, for Improvements in Harvesting Machines.

[Registered on the 15th day of September, 1884, in pursuance of the Act 16 Vic. No 24.]

BY HIS EXCELLENCY THE RIGHT HONORABLE SIR AUGUSTUS WILLIAM FREDERICK SPENCER LOFTUS (commonly called LORD AUGUSTUS LOFTUS), Knight Grand Cross of the Most Honorable Order of the Bath, a Member of Her Majesty's Most Honorable Privy Council, Governor and Commander-in-Chief of the Colony of New South Wales and its Dependencies.

TO ALL TO WHOM THESE PRESENTS SHALL COME, greeting :

WHEREAS JAMES MORROW, of No. 23, Bouverie-street, Carlton, in the Colony of Victoria, agricultural implement maker, hath by his Petition humbly represented to me that he is the author or designer of a certain invention or improvement in manufactures, that is to say, of an invention entitled "Improvements in Harvesting Machines," which is more particularly described in the specification and the sheet of drawings which are hereunto annexed ; and that he, the said Petitioner, hath deposited with the Honorable the Treasurer of the said Colony of New South Wales the sum of Twenty Pounds sterling, for defraying the expense of granting these Letters of Registration, as required by the Act of Council, sixteenth Victoria, number twenty-four ; and hath humbly prayed that I would be pleased to grant Letters of Registration, whereby the exclusive enjoyment and advantage of the said invention or improvement might be secured to him for a period of fourteen years : And I, being willing to give encouragement to all inventions and improvements in the arts or manufactures which may be for the public good, and having received a report favourable to the prayer of the said Petition, from competent persons appointed by me to examine and consider the matters stated therein and to report thereon for my information, am pleased, with the advice of the Executive Council, and in exercise of the power and authority given to me by the said Act of Council, to grant, and do by these Letters of Registration grant unto the said James Morrow, his executors, administrators, and assigns, the exclusive enjoyment and advantage of the said invention or improvement, for and during the term of fourteen years from the date hereof ; to have, hold, and exercise unto the said James Morrow, his executors, administrators, and assigns, the exclusive enjoyment and advantage thereof, for and during and unto the full end and term of fourteen years from the date of these presents next and immediately ensuing, and fully to be complete and ended : Provided always, that if the said James Morrow shall not, within three days after the granting of these Letters of Registration, register the same in the proper office in the Supreme Court, at Sydney, in the said Colony of New South Wales, then those Letters of Registration, and all advantages whatsoever hereby granted, shall cease and become void.

In witness whereof, I have hereunto set my sign manual, and have caused the present Letters of Registration to be sealed with the seal of the said Colony of New South Wales, at Government House, Sydney, in New South Wales, this thirteenth day of September, in the year of our Lord one thousand eight hundred and eighty-four.

[L.S.]

AUGUSTUS LOFTUS.

Improvements in Harvesting Machines.

SPECIFICATION of JAMES MORROW, of No. 23, Bouverie-street, Carlton, in the Colony of Victoria, agricultural implement maker, for an invention entitled "Improvements in Harvesting Machines."

THIS invention relates to those kinds of harvesting machines in which the grain is stripped, threshed, winnowed, and bagged; and consists first, in certain improvements relating to the riddles; second, to the introduction of a chaff receiver and straw carrier; third, to the discharge from the body of the machine to the wheat-elevator well; and fourth, to a cart or bag stand which is attached to the main spindle of the machine.

My improvements relating to the riddles consist—first, in suspending them from a framing attached to and springing from the front carriage so as to preserve their horizontal position under all circumstances; second, in driving them from a crank disc by a connection which slides up and down a rod affixed to their side; third, in a special arrangement of gearing, by which means I am enabled to drive them at a lower speed than the fan; and fourth, in providing a hinged flap with spikes, the angle of which can be regulated so as to distribute the grain over the sieves of the riddle.

My invention also consists in the introduction of a chaff receiver at the tail end of the machine, in which the chaff gathers (instead of spreading all over the field), and from which it can be readily discharged when full, and also in the introduction of a straw carrier placed over the top of said chaff receiver.

My invention also consists in the introduction of an Archimedean screw placed in the wheat trough across the bottom of the body of the machine for discharging the grain therefrom into the well of the wheat elevator leading to the delivery box of the bag stand.

Referring to the drawing attached showing my improved harvesting machine: Figure 1 is an elevation of the near side, showing the wheat elevator and cart or bag stand. Figure 2 is a plan. Figure 3 is an elevation of the off side, showing the white-head elevator and chaff box; and figure 4 is a back view with the chaff box and straw carrier removed so as to show the Archimedean screw for conveying the clean wheat to the well of its elevator. Figure 5 is a longitudinal vertical section on the line *a a* figure 2; and figures 6, 7, 8, and 9 are details of the riddle and its driving gear.

In these figures, A is the body of the machine and its framing, which somewhat resembles one of my stripping machines, inasmuch as it has the following parts attached to it, viz.:—The comb A¹; beaters A² on their shaft A³; hinged top or cover A⁴; spur gearing A⁵, driven by wheel on shaft A⁶, which has the clutch A⁷; clutch lever A⁸; spring A⁹; and the spur pinion A¹⁰, on it, the pinion A¹⁰ being driven by the internal driving wheel A¹¹, which is secured to the near draught wheel B, which, together with the off draught wheel B¹, is on the main shaft B², which supports the body of the machine. B³ is the front wheel supporting the circular fore-carriage and framing B⁴, which carries the worm B⁵, and its operating handle B⁶ for regulating the height of the comb A¹ by the toothed segment B⁷ bolted to the under beam B⁸ of the machine. B⁹ is the driver's seat also supported on the fore-carriage. C is the passage leading from the beaters to the hoppers of the riddles, and C¹ is the perforated dust escape door. C² the trough for catching the chaff and smaller grass seeds which pass through the lower sieve G¹.

The winnowing contrivances consist of the fan D, with its spindle D¹ working in bearings in the framing A, and having a bearing in the outer bracket D². This shaft has pulleys D³ and D⁴ keyed on it at the near side of the machine, the former for receiving motion through the medium of belt E from pulley A¹², which is on the driving shaft A⁶, and the latter for communicating motion to the wheat-elevator pulley L⁴ through the medium of belt E¹, as shown. The end on the off side of the machine has keyed on it the bevel pinion I, and also the wide pulley D⁵ for communicating motion by belt E² to the pulley F on the end of the spindle projecting out from the Archimedean screw F¹, and also for imparting motion by belt E³ to the pulley K⁴ on the white-head elevator. D⁶ is the fan casing. G is the riddle pivoted on the pin G¹ as shown, and G², G³, and G⁴ are the sieves, and G⁵ the shoot leading to the well of the white-head elevator K. G⁶ is the hopper, to which is hinged the flap or board G⁷, into which are secured the spikes G⁸. G⁹ is the curved slotted bracket attached to the hinged flap for adjusting the angle of same by the bolt G¹⁰, which passes through the cheek of the riddle. This attachment to the riddle is shown more particularly in figures 6 and 8. The riddle is suspended in a horizontal position by chains H connected to the beam or bar H¹, which is supported on the near side by the bent stay H², bolted at its lower end to the bracket H³, which also supports the end of the inner fore-carriage bar B⁴, and on the off side the beam H¹ is supported by the stay H⁴ fitted loosely at its lower end on to main shaft B². This end of the beam and stay is also supported by the counterbalance weight H⁵ working in guide H⁶, and whose suspending cord H⁷ passes over the friction pulley H⁸ and is fastened to the top end of said stay H⁴, as shown in figure 3. The motion for shaking the riddles is communicated from the fan spindle D¹ by the bevel pinion I to the larger bevel wheel I¹ on the longitudinal spindle I², working in the bracket bearing I³ at the gear end, and in the bearing I⁴ at the other. On this end is keyed the disc I⁵, having the crank pin I⁶ thereon for shaking the riddle by means of its connecting rod I⁷, which is attached to said crank pin and reaches to the staple or bar I⁸ fastened on to the outside of the riddle. I⁹ is a jointed stay for supporting the inner end of the connecting rod I⁷. This gearing is more particularly shown in figures 6, 7, and 9 of the drawings.

J is the straw carrier, formed of the laths J¹, tacked on to the endless belts J², which revolve on the flanged pulleys J³, keyed on the spindles J⁴, working in bearings J⁵, fastened to projecting struts J⁶, supported by stays J⁷, as shown. This straw carrier is driven by belt E¹ passing over pulley J⁸. The other end of said belt is on the pulley K⁴ of the white-head elevator. J⁹ is the chaff box placed at the back of the machine, and having a hinged bottom J¹⁰, which is held up by a spring catch J¹¹.

K is the white-head elevator having its well K¹, into which the shoot G⁵ of the riddle leads. K² is the lower and K³ the upper spindle of the elevator. K⁴ is the pulley by which it is driven by belt E². Said pulley K⁴ also drives the straw carrier, as above described. K⁵ are the cups of the elevator, and K⁶ is the shoot leading from the top end of the elevator to the hole K⁷ formed in the top and at the centre of beater drum. This shoot is hinged at K⁸ so as to allow of its being lifted prior to opening the cover A⁴ of the beater drum.

L is the wheat elevator, having its well L¹, into which the clean wheat is delivered by the Archimedean screw F¹. L² and L³ are its lower and upper spindles, the latter of which has the pulley L⁴ keyed thereon, and derives its motion from the belt E¹, which is driven by the pulley D⁴ on the fan spindle D¹, as shown.

Improvements in Harvesting Machines.

shown. L^5 are the elevator cups, and L^6 the delivery box, which is provided with the two openings L^7 and L^8 , having the slides L^9 and L^{10} to suit. These slides are regulated by the double lever L^{11} , so that either one or two bags may be filled at the one time.

M is the cart or bag stand connected to the main shaft of the machine by the bars M^1 and M^2 , and having the hinged side M^3 , which is held up by the spring catch M^4 . This bag stand is attached to the strap brackets M^5 by the bolt M^6 , and the bracket is supported on the bearings M^7 of the axle M^8 , on which are fixed the wheels M^9 , as shown. M^{10} is a stay for supporting said bracket, and M^{11} is a rail fixed to the inner side M^{12} of the bag stand, both of which have a number of hooks M^3 thereon, to which the bags are affixed during the operation of filling.

The mode of operation is as follows:—The harvesting machine being set in motion by being drawn forward by horse or other power, and the clutch A^1 being in gear, all the working parts are in motion and the heads of the grain pass over the comb A^1 into the beater drum, where it is threshed and delivered up the passage C to the hopper G^6 of the riddle. Here its travel is interrupted by the spiked flap G^7 , which is set at such an angle as to prevent the blast from dashing the grain on to the sieve, but allows it to gently and regularly fall over said flap on to the sieves, which sieves have a shaking motion imparted to them by the means already described, and are subjected to the blast from the fan D . This delivers the white-heads over the back end of said sieves into the shoot G^8 leading to the well K^1 of the white-head elevator K , from whence they are conveyed by said elevator and shoot K^6 to the beater drum, to be there rethreshed. The wheat or clean grain passes through said sieves and falls down into the trough containing the Archimedeian screw F^1 , by which it is conveyed to the well L^1 of the wheat elevator L , from whence it is raised by said elevator to the delivery box L^2 for delivering into the bags prepared on the bag stand M for that purpose. The drake and finer grass seeds fall through lower sieve G^4 into their receiving trough C^2 . The straw and cavings are delivered over the end of the riddle G on to the straw carrier J , which throws it off on to the ground or into a bag placed there for that purpose. The chaff delivered over the end of the riddle falls through the openings between the laths J^1 into the box J^2 , from which it may be removed at convenient periods.

What I believe to be new, and therefore claim as my improvements in harvesting machines, is—

First—The combination and arrangement of the mechanical parts herein described for suspending the riddle, and consisting of chains H , beam H^1 , stays H^2 and H^3 , bracket H^4 , weight H^5 , guide H^6 , cord H^7 , pulley H^8 , and riddle G , substantially as herein described and explained, and as illustrated in figures 1 to 5 of the drawings.

Second—The combination and arrangement of the mechanical parts herein described for giving the shaking motion to the riddle, and consisting of the bevel gear I and I^1 , spindle I^2 , bearings I^3 and I^4 , disc I^5 , crank pin I^6 , connecting rod I^7 , staple or bar I^8 , jointed stay I^9 , riddle G , and fan spindle D^1 , substantially as herein described and explained, and as illustrated in figures 3, 4, 6, 7, and 9 of the drawings.

Third—The combination of the hinged or otherwise adjustable flap G^7 (either with or without spikes G^8) with the riddle G for interrupting the passage of the grain, and distributing it to the riddle, substantially as herein described and explained, and as illustrated in figures 6 and 8 of the drawings.

Fourth—The combination with harvesting machines of the parts marked J^1 , J^2 , J^3 , J^4 , J^5 , J^6 , J^7 , J^8 forming the straw carrier J , and the parts marked J^9 , J^{10} , and J^{11} forming the chaff box, substantially as herein described and explained, and as illustrated in figures 2, 3, and 5 of the drawings.

Fifth—The combination with the other parts of my machine of the Archimedeian screw F^1 placed in the special position shown as a means for discharging the wheat into the well L^1 of the wheat elevator L , substantially as herein described, and as illustrated in figures 4 and 5 of the drawings.

Sixth—The combination with harvesting machines of the special construction of bag cart or stand M , herein described and explained, and as illustrated in figures 1, 2, and 4 of the drawings.

In witness whereof, I, the said James Morrow, have hereto set my hand and seal, this twenty-third day of July, one thousand eight hundred and eighty-four.

JAMES MORROW.

Witness—

EDWD. WATERS,
Melbourne, Patent Agent.

This is the specification referred to in the annexed Letters of Registration granted to James Morrow, the thirteenth day of August, A.D. 1884.

AUGUSTUS LOFTUS.

REPORT.

Sir,

We do ourselves the honor to report, in reply to your blank cover, 25th ultimo, No. 8,076, transmitting Mr. James Morrow's petition for the registration of "Improvements in Harvesting Machines," that we are of opinion that the prayer of the petitioner may be granted in terms of specification, drawings, and claim.

We have, &c.,
EDMUND FOSBERY,
GOTHER K. MANN.

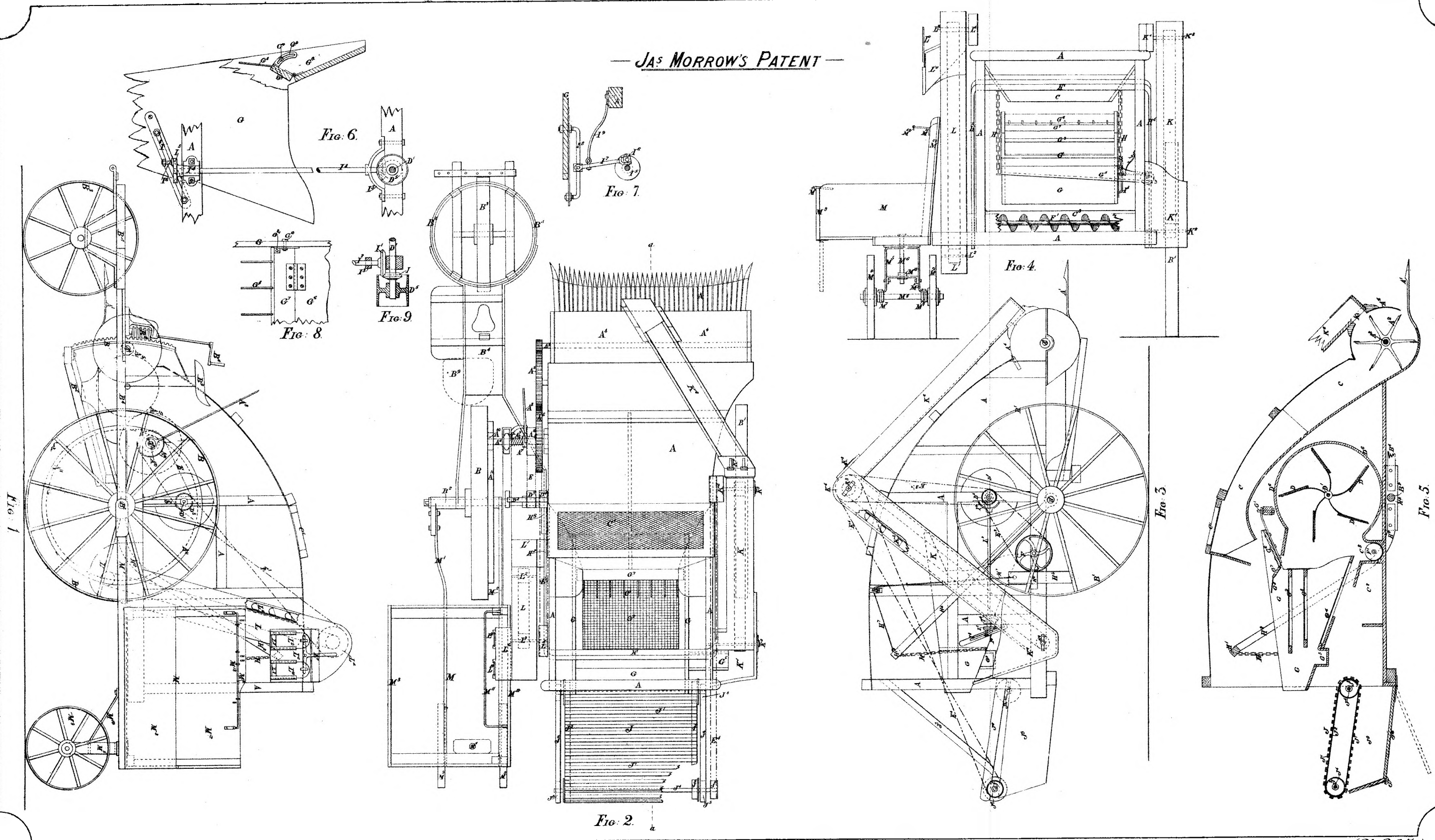
The Under Secretary of Justice.

[Drawings—one sheet.]

No. 1502.

[Assignment of No. 1325. See Letters of Registration for 1883, page 459]

— JAS MORROW'S PATENT —



This is the Sheet of Drawings referred to in the annexed Letters of Registration, granted to James Morrow, the thirteenth day of August, A.D. 1884.
Augustus Loftus.

PHOTO-LITHOGRAPHED AT THE GOVT. PRINTING OFFICE, SYDNEY, NEW SOUTH WALES.

(Sig 245)



A.D. 1884, 16th September. No. 1503.

BLANCK'S SINGLE AND DOUBLE ARM ECONOMICAL REVERSIBLE ROTARY ENGINE.

LETTERS OF REGISTRATION to Karl Luckas Blanck, for an Invention entitled Blanck's Single and Double Arm Economical Reversible Rotary Engine.

[Registered on the 18th day September, 1884, in pursuance of the Act 16 Vic. No. 24.]

BY HIS EXCELLENCY THE RIGHT HONORABLE SIR AUGUSTUS WILLIAM FREDERICK SPENCER LOFTUS (commonly called LORD AUGUSTUS LOFTUS), Knight Grand Cross of the Most Honorable Order of the Bath, a Member of Her Majesty's Most Honorable Privy Council, Governor and Commander-in-Chief of the Colony of New South Wales and its Dependencies.

TO ALL TO WHOM THESE PRESENTS SHALL COME, greeting:

WHEREAS KARL LUCKAS BLANCK, of 132, Queen-street, in the City of Melbourne and Colony of Victoria, gentleman, hath by his petition humbly represented to me that he is the author or designer of a certain invention or improvement in manufactures, that is to say, of an invention entitled "Blanck's Single and Double Arm Economical Reversible Rotary Engine," which is more particularly described in the specification and the sheet of drawings which are hereunto annexed; and that he, the said Petitioner, hath deposited with the Honorable the Treasurer of the said Colony of New South Wales the sum of Twenty Pounds sterling, for defraying the expense of granting these Letters of Registration, as required by the Act of Council, sixteenth Victoria, number twenty-four, and hath humbly prayed that I would be pleased to grant Letters of Registration, whereby the exclusive enjoyment and advantage of the said invention or improvement might be secured to him for a period of fourteen years: And I, being willing to give encouragement to all inventions and improvements in the arts or manufactures which may be for the public good, and having received a report favourable to the prayer of the said Petition from competent persons appointed by me to examine and consider the matters stated therein and to report thereon for my information, am pleased, with the advice of the Executive Council, and in exercise of the power and authority given to me by the said Act of Council, to grant, and do by these Letters of Registration grant unto the said Karl Luckas Blanck, his executors, administrators, and assigns the exclusive enjoyment and advantage of the said invention or improvement, for and during the term of fourteen years from the date hereof; to have, hold, and exercise unto the said Karl Luckas Blanck, his executors, administrators, and assigns, the exclusive enjoyment and advantage thereof, for and during and unto the full end and term of fourteen years from the date of these presents next and immediately ensuing, and fully to be complete and ended: Provided always, that if the said Karl Luckas Blanck shall not, within three days after the granting of these Letters of Registration, register the same in the proper office in the Supreme Court, at Sydney, in the said Colony of New South Wales, then these Letters of Registration and all advantages whatsoever hereby granted, shall cease and become void.

In witness whereof, I have hereunto set my sign manual, and have caused the present Letters of Registration to be sealed with the seal of the said Colony of New South Wales, at Government House, Sydney, in New South Wales, this sixteenth day of September, in the year of our Lord one thousand eight hundred and eighty-four.

[L.S.]

AUGUSTUS LOFTUS.

Blanck's Single and Double Arm Economical Reversible Rotary Engine.

SPECIFICATION.

BLANCK'S Single and Double Arm Economical Reversible Rotary Engine is an improvement in the construction of the Rotary Engine, and the mode in which it is worked effects a great saving in steam by enabling it to be applied in such a way that it will do much more work than the same quantity will do in any ordinary engine now in common use.

The improvement consists in the application of a newly invented door, which is fitted in the top of the engine, the said door being raised by means of levers, and also in the saving of expense and labour by making the exhausters and the steam ports identical.

The single and double arm economical reversible rotary engine consists of a circular cylinder C on a stand, such stand being fitted with screws to secure the stability of the engine when in position on the floor of an engine-room, either in a building or a vessel. Within the cylinder is placed a piston P, to which is attached two arms A, which rotate with the piston within the cylinder. The engine is furnished with two steam ports S, either of which is used singly; and by changing from one to the other the action of the engine is reversed, this change being effected by means of a tap T. The axis (axis) of the piston to which the arms are attached passes at either extremity through a circular plate or cover M, which is fixed to the outside of the cylinder with which it corresponds in diameter. To each side of that part of the axis of the piston which passes through and projects beyond the cylinder plate or cover is attached two lifters L, diametrically opposed to each other, which, by the rotation of the piston, alternately raise a lever N on either side of the cylinder plate or cover, the said levers working on pivots firmly fixed to the outside of the cylinder plates or covers, and at right angles to them. A spindle passes through the upper end of each lever, to the centre of which is attached the door, which is opened by means of the united action of the levers, and closed by means of spiral springs K when the levers cease to act. To the centre of the spindle which passes through the top of the door D and the upper ends of the levers, is attached a wheel V, which is half buried in a recess made for it in the top of the door D. This wheel as the door is depressed opens the steam ports (of which one acts as an exhauster, and the other as a steam port) by means of rods attached to them. When the steam is within the cylinder, in its effort to escape, it forces round the arm until it has completed half a revolution, when the steam escapes by an exhauster at the bottom of the cylinder. This applies only when the two arms are in use. While the exhaustion is proceeding the second arm obtains to such a position that a fresh quantity of steam is admitted, the steam ports which were momentarily closed by the springs O when relieved from the action of the wheel attached to the door being again opened by the depression of the door, and acts upon the second arm as it did upon the first, and the continued repetition of this action produces the rotary motion. When a single arm is used, the exhauster at the bottom is closed, and one of the exhausters on the top acts. In this case the arm makes one revolution. I do hereby for myself, my executors, administrators, and assigns covenant with Her Majesty, her heirs and successors, that I believe the said improvement and invention to be a new improvement and invention as to the public use and exercise thereof, and that I do not know or believe that any other person than myself is the true and first inventor of the said invention, and that I will not deposit these presents at the office of the Department of Justice, Macquarie-street, Sydney, with any such knowledge or belief as last aforesaid.

In witness whereof, I have this, the twenty-seventh day of July, 1884, attached my hand and seal.
KARL LUCKAS BLANCK.

This is the specification referred to in the annexed Letters of Registration granted to Karl Luckas Blanck, this sixteenth day of September, A.D. 1884.

AUGUSTUS LOFTUS.

REPORT.

Sir,

Referring to your B.C. memo. of 5th instant, forwarding a petition from Mr. K. L. Blanck, for Letters of Registration for an invention entitled "Blanck's Single and Double Arm Economical Reversible Rotary Engine," we have the honor to state that having examined the plans and specification attached to the petition, we recommend that Letters of Registration be issued to the petitioner for the invention referred to.

Sydney, 12 August, 1884.

We have, &c.,

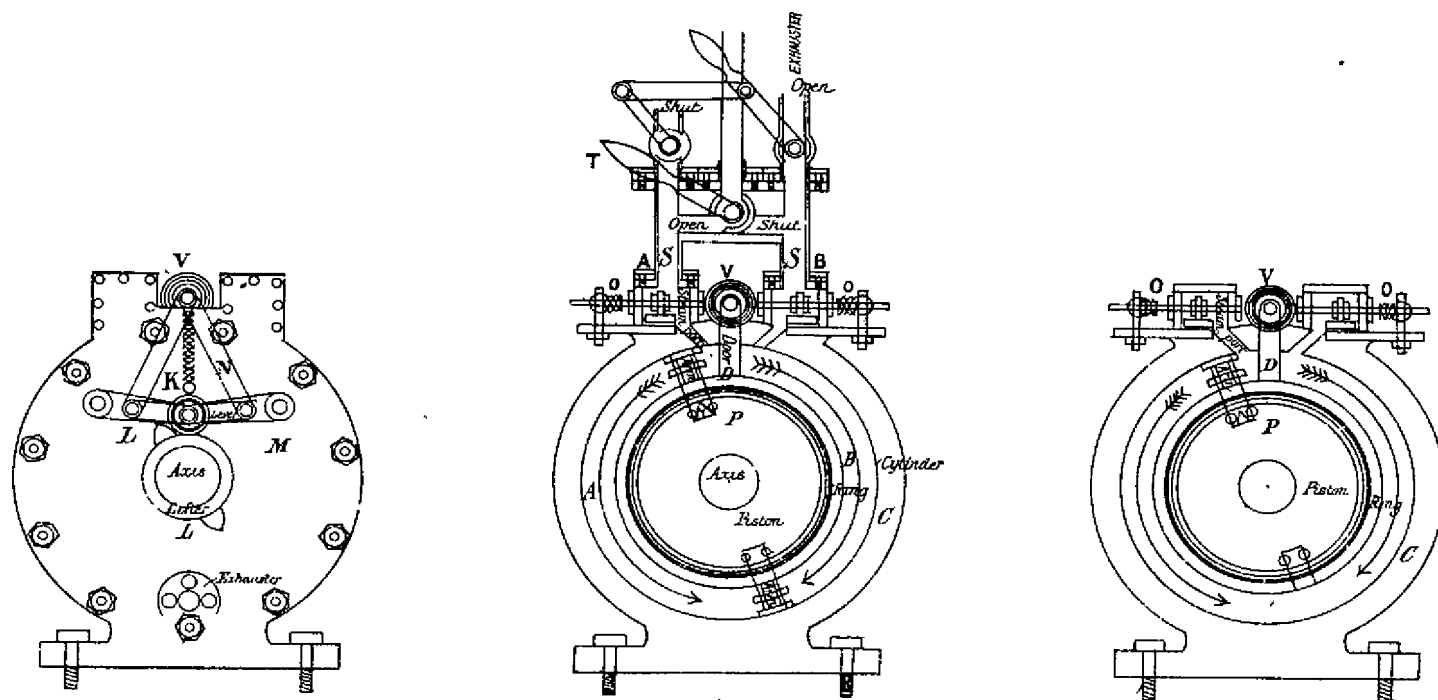
JOHN WHITTON.
E. O. MORIARTY.

The Under Secretary of Justice.

[Drawings—one sheet.]

No. 1504.

[Assignment of No. 1471.]



This is the Sheet of Drawings referred to in the annexed Letters of Registration granted to Karl Lukas Blanck, the sixteenth day of September, A.D., 1884.

Augustus Loftus.

(Sig: 245-)



A.D. 1884, 22nd September. No. 1505.

IMPROVEMENTS IN HYDRO-CARBURETTED AIR ENGINES.

**LETTERS OF REGISTRATION to Eugène Etève and Jean André de Braam, for
Improvements in Hydro-carburetted Air Engines.**

[Registered on the 23rd day of September, 1884, in pursuance of the Act 16 Vic. No. 24.]

BY HIS EXCELLENCY THE RIGHT HONORABLE SIR AUGUSTUS WILLIAM FREDERICK SPENCER LOFTUS (commonly called LORD AUGUSTUS LOFTUS), Knight Grand Cross of the Most Honorable Order of the Bath, a Member of Her Majesty's Most Honorable Privy Council, Governor and Commander-in-Chief of the Colony of New South Wales and its Dependencies.

TO ALL TO WHOM THESE PRESENTS SHALL COME, greeting :

WHEREAS EUGÈNE ÈTÈVE, electrician, and JEAN ANDRÉ DE BRAAM, civil engineer, both of the City of Paris, in the Republic of France, have by their Petition humbly represented to me that they are the authors or designers of a certain invention or improvement in manufactures, that is to say, of an invention entitled "Improvements in Hydro-carburetted Air Engines," which is more particularly described in the specification and the sheet of drawings which are hereunto annexed; and that they, the said Petitioners, have deposited with the Honorable the Treasurer of the said Colony of New South Wales the sum of Twenty Pounds sterling, for defraying the expense of granting these Letters of Registration, as required by the Act of Council, sixteenth Victoria, number twenty-four; and have humbly prayed that I would be pleased to grant Letters of Registration, whereby the exclusive enjoyment and advantage of the said invention or improvement might be secured to them for a period of fourteen years: And I, being willing to give encouragement to all inventions and improvements in the arts or manufactures which may be for the public good, and having received a report favourable to the prayer of the said Petition, from competent persons appointed by me to examine and consider the matters stated therein and to report thereon for my information, am pleased, with the advice of the Executive Council, and in exercise of the power and authority given to me by the said Act of Council, to grant, and do by these Letters of Registration grant unto the said Eugène Etève and Jean André de Braam, their executors, administrators, and assigns, the exclusive enjoyment and advantage of the said invention or improvement, for and during the term of fourteen years from the date hereof; to have, hold, and exercise unto the said Eugène Etève and Jean André de Braam, their executors, administrators, and assigns, the exclusive enjoyment and advantage thereof, for and during and unto the full end and term of fourteen years from the date of these presents next and immediately ensuing, and fully to be complete and ended: Provided always, that if the said Eugène Etève and Jean André de Braam shall not, within three days after the granting of these Letters of Registration, register the same in the proper office in the Supreme Court, at Sydney, in the said Colony of New South Wales, then these Letters of Registration, and all advantages whatsoever hereby granted, shall cease and become void.

In witness whereof, I have hereunto set my sign manual, and have caused the present Letters of Registration to be sealed with the seal of the said Colony of New South Wales, at Government House, Sydney, in New South Wales, this twenty-second day of September, in the year of our Lord one thousand eight hundred and eighty-four.

[L.S.]

AUGUSTUS LOFTUS.

Improvements in Hydro-carburetted Air Engines.

SPECIFICATION of EUGÈNE ÈTEVE, electrician, and JEAN ANDRÉ DE BRAAM, civil engineer, both of the City of Paris, in the Republic of France, for an invention for "Improvements in Hydro-carburetted Air Engines."

The hydro-carburetted engine forming the subject of the present invention, as represented by the accompanying drawings, is a double-cylinder single-action engine, the cylinders being vertical, but they may also be horizontal, or the engine may have a single cylinder; in either case the cylinder or the cylinders may be vertically or horizontally disposed, the explosive mixture acting alternately on each face of the piston or pistons, as the case may be.

The air is hydro-carburetted by vaporization, and is stored in a reservoir separate from the cylinder or cylinders, so that its ignition can be equally well effected on one or both sides or faces of the piston alternately. The improvements are equally applicable to rotary engines. Fig. 1 is a front elevation of the machine; fig. 2 is a plan of the same; fig. 3 is a vertical section through the axis of one of the cylinders; fig. 4 shows the discharging commutator in detail. The cylinders A and B have refrigerating wings or fins, and are supported by the frame C, which may be of any desired form or dimensions the better to arrange the grouping of the various parts forming the apparatus.

The pistons P are directly connected by the rods D¹ D¹ to the cranks E¹ E¹ of the driving shaft E. To this shaft is connected the fly-wheel V, the transmitting pulley or pulleys, and a conical pinion X, which transfers the motion of the shaft perpendicularly by aid of a similar pinion F¹ mounted on the vertical axis F. This axis F at its lower end simultaneously actuates the circular slide-valves T of the cylinders A B by means of similar pinions F² T¹. These valves receive the hydro-carburetted gas in the centre, and admit it to the cylinders at the first $\frac{1}{2}$ of the forward stroke; escape is effected in the open air (at the $\frac{1}{2}$ return stroke of the piston) through the pipe K, which communicates with the support K¹, in which the escapes from the valves are led by the hollow shaft on which these valves are mounted.

The driving-shaft is supported by the frame E² E². An eccentric G, mounted on the driving-shaft, E by aid of its rod G¹, communicates an oscillatory motion to a lever L, which connects its movements with those of another lever L¹, keyed with it on the shaft L². The first lever L¹ works a double-action pump J which forces the air into a receiver J¹ cast with the frame, and thence to the intermediate reservoir M, to make the explosive mixture, which is then distributed in each of the cylinders.

The recipient J¹ is supplied with a valve J² to keep the injected air at a fixed pressure. The small pump I, which the second lever L works, is single-acting; it forces air into a petroleum reservoir N, having a valve N¹, which allows the compressed air to escape, when the internal pressure exceeds a certain limit, appropriately determined, and slightly superior to the pressure of the air compressed by the pump J. The air thus compressed passes through the pipe W, filters through sponges placed in a regulating tap W¹, shown in section fig. 5, whose elongated port allows of a great displacement with a very little variation in delivery.

Further on the air traverses another tap S, from whence debouches another compressed air-pipe L from the recipient J¹. From the tap S the two pipes U U¹ descend, one conducting the hydro-carburet, the other the compressed air in a small conduit U², so that the starting tap being open the hydro-carburet is projected and is vaporized by the air meeting it. This mixture by vaporization of the hydro-carburet and compressed air spreads, and is stored in the recipient or vaporizer, in which a certain quantity of air penetrates directly from the reservoir J¹, as already explained, for forming the explosive mixture.

Pipes put the boxes of the valves T in communication with the vaporizer M. In some convenient situation on these pipes wire gauze is placed, the gas passing through which prevents the contents of the reservoir J¹ from ignition by flame, heating, or explosion.

Vaporization by compressed air and petroleum forms in the independent recipient M, with an admission of slightly less compressed air, an explosive mixture, which is introduced, as already described, by the alternate actions of the slide-valves T into the cylinders A and B, where it is electrically discharged, as follows:—

One or more batteries P conduct the electric fluid to a terminal P¹ of the frame. It is again taken by a wire F which leads it to a terminal of the bobbin G, transforming the dynamic into static electricity for producing the sparks. The other terminal leads the current to a commutator C. The current of these two conducting wires is constant when one or other of the cheeks O¹ O² of the disc O (mounted on the shaft of the slide-valves) drives a small roller O³ in connection with one of the wires against a plate O⁴ bearing the other wire.

A fourth wire leaving the bobbin is connected to a crank V, keyed to the shaft of the pumps.

The wires starting from each of the cylinders come in front of an arm of the crank V, which, in its oscillatory movements, communicates with each of them successively.

Fig. 6 shows another method of producing the electric contacts by means of the blades V¹ V², which balance with the oscillatory shaft L² of the pumps, and establish the current on one or other of the "touches" V³ V⁴; these have a support common to both, with a terminal V⁵ in communication with a battery by a wire. The blades V¹ V² are fixed to the shaft L² by means of the terminal L with wire from the bobbin. The two ends of the shaft L² bearing this arrangement a continuity of the current is established in the battery.

The current being established with the commutator the electric spark is produced either in the cylinder A or B, according as the button on the crank touches one or other of the wires communicating with their respective cylinders. In order to prevent any failure in producing the spark, a small conducting wire connected to the cylinder itself is carried to the wire from the crank.

What is claimed as the invention, and is desired to be secured by Letters of Registration, is—

- 1st. Generating and storing under pressure in a reservoir (separate from the driving cylinder or cylinders A and B) of an explosive mixture produced partly by evaporation of a hydro-carburet, petroleum, or some equivalent under pressure in a jet of air also under pressure; and partly of a volume of air under pressure directed simultaneously to the recipient in which the explosive mixture is stored. The whole immediately before its completion for each stroke of the piston. This formation of the explosive mixture is effected by vaporization, producing more or less infinitesimal globules of hydro-carburet, whether the latter is or is not previously mixed or charged with oxygen.

2nd.

Improvements in Hydro-carburetted Air Engines.

- 2nd. The tap shown in detail in fig. 5, with special port or opening for regulating the delivery of the hydro-carburet, according to whether it is required to make a mixture more or less rich in hydro-carburet, or whether it is desired to increase the speed of the engine, or if the resistance becomes more or less important.
- 3rd. The two-way starting tap for the subsequent mixture of the air and the hydro-carburet, both under pressure, which mixture is effected on entering the storage reservoir by means of one, two, or more jets vaporizing the hydro-carburet in the midst of the compressed air.
- 4th. The previous filtration of the hydro-carburet under pressure which prevents obstruction of the vaporizing jets by solid matters, which it always contains unless this operation is performed.
- 5th. The separation of the driving cylinders and the storage reservoir, by the interposition of metal gauze, or some equivalent preservative of flame and heat.
- 6th. The combination of two air-pumps, single or double-acting, compressing the air taken from the atmosphere at varied pressures; the one that produces the greatest pressure directing the air to the hydro-carburet reservoir, and the other at an inferior pressure supplying the reservoir with the explosive mixture, and the jets vaporizing the hydro-carburet in the reservoir.

We claim also the right to apply to our engines a regulator participating in the motion of the engine, and automatically regulating the opening of the tap admitting the hydro-carburet.

Although a machine is represented in the drawing as having two vertical single-action cylinders, which arrangement prevents heating the parts, we reserve the right of combining our improvements wholly, or in part, for constructing engines of variable dimensions, single or double acting, with either one or two cylinders, vertical or horizontal, or rotary motors, and generally applying the principle.

In witness whereof, we, the said Eugène Etève and Jean André de Braam, have hereunto set our hands and seals, this twenty-third day of May, 1884.

EUGÈNE ETÈVE.

JEAN ANDRÉ DE BRAAM.

Signed, sealed, and delivered by the said Eugène Etève and Jean André de Braam, in the presence of—

A. BLETTY,
Civil Engineer, 2, Boulevard de Strasbourg, at Paris.
HENRY WILLOUGHBY,
British Vice-Consul at Paris.

This is the specification referred to in the annexed Letters of Registration granted to Eugène Etève and Jean André de Braam, the 22nd day of September, A.D. 1884.

AUGUSTUS LOFTUS.

REPORT.

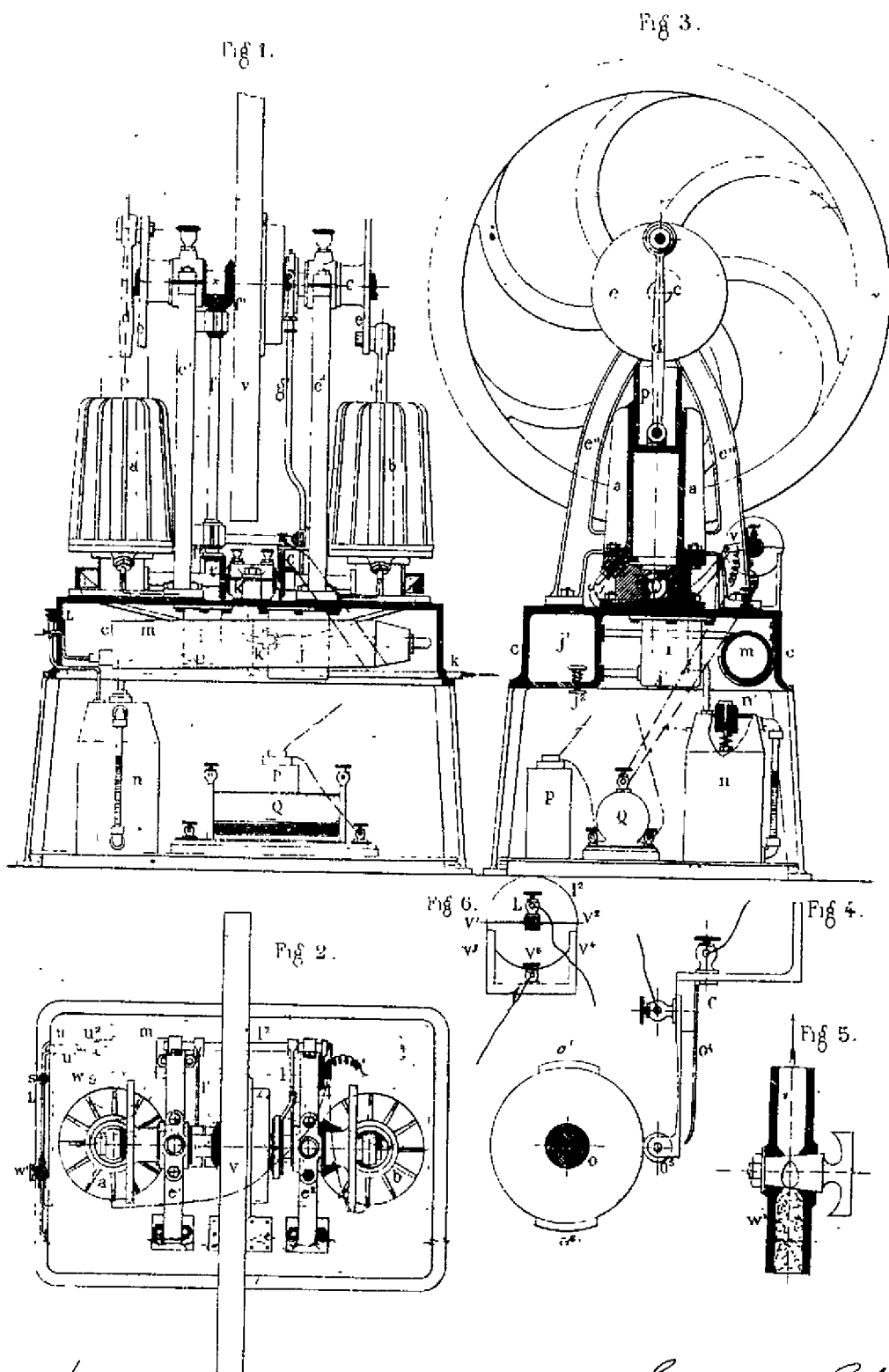
Sir,

Referring to your B.C. memo. of the 31st ultimo, forwarding a petition from Eugène Etève and Jean André de Braam, for Letters of Registration for an invention entitled "Improvements in Hydro-carburetted Air Engines," we have the honor, having examined the plan and specification accompanying the petition, to recommend that Letters of Registration be issued in terms of the prayer of the petitioner.

We have, &c.,

JOHN WHITTON,
E. O. MORIARTY.

The Under Secretary of Justice.



A. Bletet
Henry Withoughby
Mechanical Engineers at Paris.
Brussels, 23rd 1884.

Eugene Etiev
Jean Andre de Braam

This is the Sheet of Drawings referred to in the annexed Letters of Registration granted to Eugene Etiev, and Jean Andre de Braam, the twenty second day of September, A.D. 1884.
(Sig. 245-)
Augustus Loftus.



A.D. 1884, 22nd September. No. 1506.

AN IMPROVED PRESS, CHIEFLY FOR THE PURPOSE OF PRESSING HAY AND STRAW.

LETTERS OF REGISTRATION to William M'Lean, for an Improved Press, chiefly for the purpose of Pressing Hay and Straw.

[Registered on the 23rd day of September, 1884, in pursuance of the Act 16 Vic. No. 24.]

BY HIS EXCELLENCY THE RIGHT HONORABLE SIR AUGUSTUS WILLIAM FREDERICK SPENCER LOFTUS (commonly called LORD AUGUSTUS LOFTUS), Knight Grand Cross of the Most Honorable Order of the Bath, a Member of Her Majesty's Most Honorable Privy Council, Governor and Commander-in-Chief of the Colony of New South Wales and its Dependencies.

TO ALL TO WHOM THESE PRESENTS SHALL COME, greeting :

WHEREAS WILLIAM M'LEAN, of Elizabeth-street, Melbourne, in the Colony of Victoria, hath by his Petition humbly represented to me that he is the assignee—so far as the Colony of New South Wales is concerned—of William Rank, of Heidelberg, in the said Colony of Victoria, chaffcutter, who is the author or designer of a certain invention or improvement in manufactures, that is to say, of an invention entitled "An Improved Press, chiefly for the purpose of Pressing Hay and Straw," which is more particularly described in the specification and the drawing which are herunto annexed; and that he, the said Petitioner, hath deposited with the Honorable the Treasurer of the said Colony of New South Wales the sum of Twenty Pounds sterling, for defraying the expense of granting these Letters of Registration, as required by the Act of Council, sixteenth Victoria, number twenty-four; and hath humbly prayed that I would be pleased to grant Letters of Registration, whereby the exclusive enjoyment and advantage of the said invention or improvement might be secured to him for a period of fourteen years: And I, being willing to give encouragement to all inventions and improvements in the arts or manufactures which may be for the public good, and having received a report favourable to the prayer of the said Petition, from competent persons appointed by me to examine and consider the matters stated therein and to report thereon for my information, am pleased, with the advice of the Executive Council, and in exercise of the power and authority given to me by the said Act of Council, to grant, and do by these Letters of Registration grant unto the said William M'Lean, his executors, administrators, and assigns, the exclusive enjoyment and advantage of the said invention or improvement, for and during the term of fourteen years from the date hereof; to have, hold, and exercise unto the said William M'Lean, his executors, administrators, and assigns, the exclusive enjoyment and advantage thereof, for and during and unto the full end and term of fourteen years from the date of these presents next and immediately ensuing, and fully to be complete and ended: Provided always, that if the said William M'Lean shall not, within three days after the granting of these Letters of Registration, register the same in the proper office in the Supreme Court, at Sydney, in the said Colony of New South Wales, then these Letters of Registration, and all advantages whatsoever hereby granted, shall cease and become void.

In witness whereof, I have hereunto set my sign manual, and have caused the present Letters of Registration to be sealed with the seal of the said Colony of New South Wales, at Government House, Sydney, in New South Wales, this twenty-second day of September, in the year of our Lord one thousand eight hundred and eighty-four.

[L.S.]

AUGUSTUS LOFTUS.

An Improved Press, chiefly for the purpose of Pressing Hay and Straw.

SPECIFICATION of William M'Lean, of Elizabeth-street, Melbourne, in the Colony of Victoria, assignee of William Rank, of Heidelberg, in the said Colony, chaffcutter, the author or designer of an invention entitled "An Improved Press, chiefly for the purpose of Pressing Hay and Straw."

My improved press has been designed principally for the purpose of pressing hay and straw into bundles, although it may be used for pressing other substances. The whole of my press is made of wooden bars hinged on iron rods or bolts, so that when compressing the hay, &c., it is like a cage whose sides are higher than its top. Each side consists of, say, three wooden bars, hinged to an iron rod or bolt at either side of the bottom, which consists preferably of a wooden table, stayed underneath by iron bars, which table is also hinged on said rods or bolts. To the inner side of each of the side bars, and at right angles thereto, I attach wooden tongues or projecting pieces so as to form the top of the cage when in the act of compressing.

If preferred, the bottom may consist of a series of wooden bars and the sides of solid planking, although I prefer the construction first herein described and illustrated in my drawings.

For ordinary purposes common double blocks will do for the tackle, but when a great strain is required I would apply a windlass or winch barrel for increasing the power.

In the drawings which accompany this specification I have shown a perspective view of the simplest form of my press, A being the sides and B the bottom; both A and B being hinged to the bolts CC. DD are the two sets of tongues or projecting pieces which form the top of the cage. These are bolted at top to cross-bar E, their outer ends resting on cross-bar F, both of which cross-bars are securely fastened to the sides in the position shown. G is the hauling rope.

In operation I open out both sides of my press till they rest on the ground, then put in the hay or other material to be pressed, then haul up the sides by the rope G, and fasten the end to any suitable holder; then tie up the compressed material, loosen the rope, and discharge the bundle.

What I claim as new, and for which I am desirous of securing Letters of Registration, is:—

The construction of presses, chiefly for the purpose of pressing hay and straw, in which the pressure is given by hauling together the two sides, substantially as herein described and explained, and as illustrated in my drawings.

In witness whereof, I, the said William M'Lean, have here to set my hand and seal, this thirtieth day of July, one thousand eight hundred and eighty-four.

Witness—

WILLM. G. SEVIER, 69, Elizabeth-street, Melbourne, Clerk.

WILLIAM M'LEAN.

This is the specification referred to in the annexed Letters of Registration granted to William M'Lean, the twenty-second day of September, A.D. 1884.

AUGUSTUS LOFTUS.

REPORT.

Sir,

Sydney, 6 August, 1884.

We do ourselves the honor to return to you the documents transmitted for our report under your B.C. communication, dated the 2nd instant, No. 84-8275, which have reference to Mr. William M'Lean's Petition for Letters of Registration for his invention of "An Improved Press, chiefly for the purpose of Pressing Hay and Straw," and we have to state that we see no objection to the issue of the said Letters of Registration in terms with the Petition, specification, and drawing.

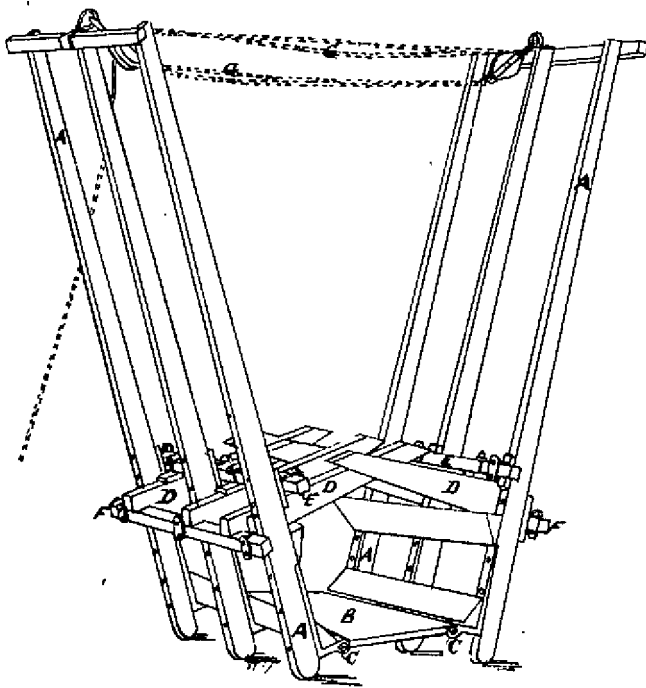
We have, &c.,

EDMUND FOSBERY.
E. C. CRACKNELL.

The Under Secretary of Justice.

[Drawings—one sheet.]

— WILLIAM RANK'S PATENT. —



*This is the Sheet of Drawings referred to in the aforesaid
Letters of Registration granted to William M'Lean, the
twenty second day of September A.D. 1884.*

Augustus Loftus.



A. D. 1884, 22nd September. No. 1507.

IMPROVED MECHANISM FOR SUPPORTING THE FRONT END OF STRIPPING AND HARVESTING MACHINES.

LETTERS OF REGISTRATION to James Morrow, for Improved Mechanism for supporting the front end of Stripping and Harvesting Machines.

[Registered on the 23rd day of September, 1884, in pursuance of the Act 16 Vic. No. 24.]

BY HIS EXCELLENCY THE RIGHT HONORABLE SIR AUGUSTUS WILLIAM FREDERICK SPENCER LOFTUS (commonly called LORD AUGUSTUS LOFTUS), Knight Grand Cross of the Most Honorable Order of the Bath, a Member of Her Majesty's Most Honorable Privy Council, Governor and Commander-in-Chief of the Colony of New South Wales and its Dependencies.

TO ALL TO WHOM THESE PRESENTS SHALL COME, greeting:

WHEREAS JAMES MORROW, of No. 23, Bouverie-street, Carlton, in the Colony of Victoria, agricultural implement manufacturer, hath by his Petition humbly represented to me that he is the author or designer of a certain invention or improvement in manufactures, that is to say, of an invention entitled "Improved Mechanism for supporting the front end of Stripping and Harvesting Machines," which is more particularly described in the specification and the sheet of drawings which are hereto annexed; and that he, the said Petitioner, hath deposited with the Honorable the Treasurer of the said Colony of New South Wales the sum of Twenty Pounds sterling, for defraying the expense of granting these Letters of Registration, as required by the Act of Council, sixteenth Victoria, number twenty-four; and hath humbly prayed that I would be pleased to grant Letters of Registration, whereby the exclusive enjoyment and advantage of the said invention or improvement might be secured to him for a period of fourteen years: And I, being willing to give encouragement to all inventions and improvements in the arts or manufactures which may be for the public good, and having received a report favourable to the prayer of the said Petition, from competent persons appointed by me to examine and consider the matters stated therein and to report thereon for my information, am pleased, with the advice of the Executive Council, and in exercise of the power and authority given to me by the said Act of Council, to grant, and do by these Letters of Registration grant unto the said James Morrow, his executors, administrators, and assigns, the exclusive enjoyment and advantage of the said invention or improvement for and during the term of fourteen years from the date hereof; to have, hold, and exercise unto the said James Morrow, his executors, administrators, and assigns, the exclusive enjoyment and advantage thereof, for and during and unto the full end and term of fourteen years from the date of these presents next and immediately ensuing, and fully to be complete and ended: Provided always, that if the said James Morrow shall not, within three days after the granting of these Letters of Registration, register the same in the proper office in the Supreme Court, at Sydney, in the said Colony of New South Wales, then these Letters of Registration, and all advantages whatsoever hereby granted, shall cease and become void.

In witness whereof, I have hereunto set my sign manual, and have caused the present Letters of Registration to be sealed with the seal of the said Colony of New South Wales, at Government House, Sydney, in New South Wales, this twenty-second day of September, in the year of our Lord one thousand eight hundred and eighty-four.

[L.S.]

AUGUSTUS LOFTUS.

Improved Mechanism for supporting the front end of Stripping Machines, &c.

SPECIFICATION of JAMES MORROW, of No. 23, Bouverie-street, Carlton, in the Colony of Victoria, agricultural implement manufacturer, for an invention entitled "Improved Mechanism for supporting the front end of Stripping and Harvesting Machines."

THIS invention of improved mechanism for supporting the front end of stripping and harvesting machines has been devised for the purpose, first, of enabling the wheels of said front end to adapt themselves to the inequalities of the ground; second, to assist in adjusting the height of such front end; and third, to do so and yet effect a saving in the cost of constructing this portion of such machines. According to my invention I dispense with the usual circular wheel-frame, and I support the front end of the machine by a sort of king-bolt which is connected to the framing above, and which centres on the axle of the leading wheels below. I prefer to make such king-bolt forked at its lower end, so as to sit and be centred at the middle of the axle of said wheels to which it is attached by a pin or stud which passes through the axle and through the two prongs of the fork which are perforated for the purpose. To provide for the loss of strength occasioned by the perforation of the axle to receive said pin, I make it of larger diameter at this point. I attach a guide lever to the top or any convenient part of said king-bolt in substantially the same way as guide levers are now attached to the fore carriage. I also provide two movable collars on said king-bolt, one above and one below the framing or body, by the adjustment of which the front end of the machine can be raised and lowered at will. This is not as a substitute for, but as a help to the usual worm-wheel and rack by which the height of the front end of said machines are usually regulated.

Referring to my drawings, figures 1, 2, and 3 show respectively plan, side view, and front view of the best method I know of carrying my invention into effect; and figure 4 is a side view of the king-bolt or supporting bar.

In these figures A is the wooden platform forming the front end of the machine. This platform is secured between side bars A¹, whose back ends are supported on the main axle of the machine. A² is a transverse bolt on which to secure the draw-bar A³, which has the shackle A⁴ thereon. A⁵ is the upper, and A⁶ the lower plates fastened by bolts A⁷ to the wooden platform, which with the plates has a suitable round hole through it for the reception of the vertical supporting bar or king-bolt B, which works and is held therein between the loose collar B¹, and the collar formed on the end of the pole socket B². The bar B is bifurcated or forked at its lower end at B³ so as to allow the axle C to be fitted between it by the bolt C¹, which passes through a hole provided in said forked end and the axle, and on which bolt said vertical bar or king-bolt rides. C² C³ are the wheels fitted on the axle between the collars C³, and held thereon by the pins C⁴, as is well understood. B⁴ is a lower draw-bar attached to the pole socket B² by the bolt B⁵, and is only to be used when the pole is not used. D is the steering rod, having a looped end, D¹, which passes over and is attached to the vertical bar B by the pin D². D³ is the rack for said steering rod.

It will at once be seen that by releasing the collars B¹ and B² and fastening them at a higher or lower position within the range of the vertical bar B, that the front end of the machine will be raised or lowered, as the case may be. It will also be seen that by centring the vertical bar on the axle by means of the bolt C¹ the wheels find their own level when travelling over uneven ground, thereby preventing the frame above from being twisted or strained, as is the case when the axles are made rigid with their frame.

Having thus described the nature of my invention, and the advantages to be derived from it, I would have it understood that what I believe to be new, and therefore claim as my improved mechanism for supporting the front end of stripping and harvesting machines, is—

- First—The vertical bar or king-bolt B centred on the axle C of the front wheels C², and combined with the front end of the framing or body, A, of stripping and harvesting machines, substantially as herein described and explained, and as illustrated in my drawings.
- Second—In combination with such parts A, B, C, and C², the use of adjustable collars, B¹ and B², for adjusting or assisting to adjust the height of the front end of stripping and harvesting machines, substantially as herein described and explained, and as illustrated in my drawings.

In witness whereof, I, the said James Morrow, have hereto set my hand and seal, this seventh day of August, 1884.

Witness—

EDWD. WATERS,
Melbourne, Patent Agent.

JAMES MORROW.

This is the specification referred to in the annexed Letters of Registration granted to James Morrow, the twenty-second day of September, A.D. 1884.

AUGUSTUS LOFTUS.

REPORT.

Sir,

We do ourselves the honor to report, in reply to your blank cover transmitting Mr. James Morrow's Petition for the registration of an invention entitled "Improved Mechanism for supporting the front end of Stripping and Harvesting Machines," that we are of opinion the prayer of the Petition may granted in terms of his specification, drawings, and claim.

The Under Secretary of Justice.

Sydney, 16 August, 1884.

We have, &c.,

EDMUND FOSBERY.
GOTHEB K. MANN.

JAS MORROW'S PATENT

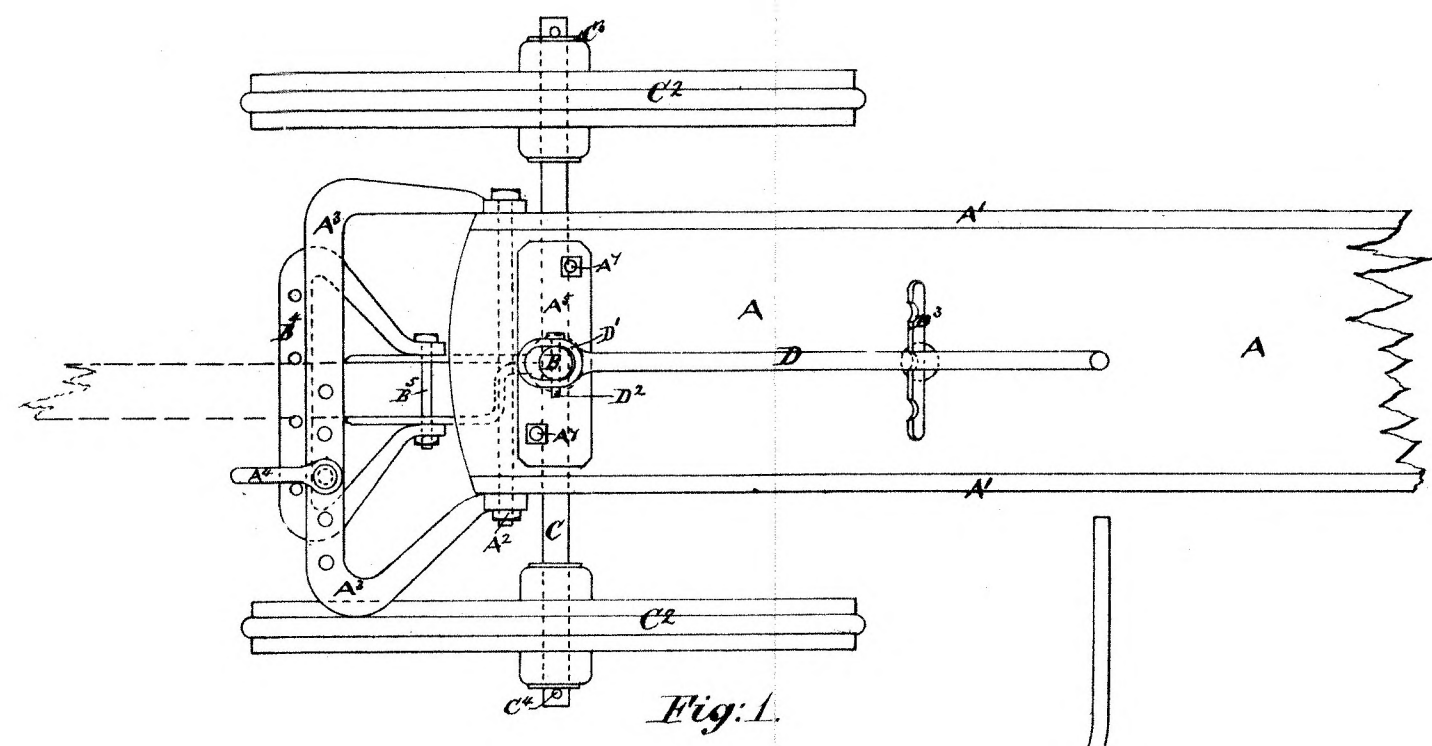


Fig. 1.

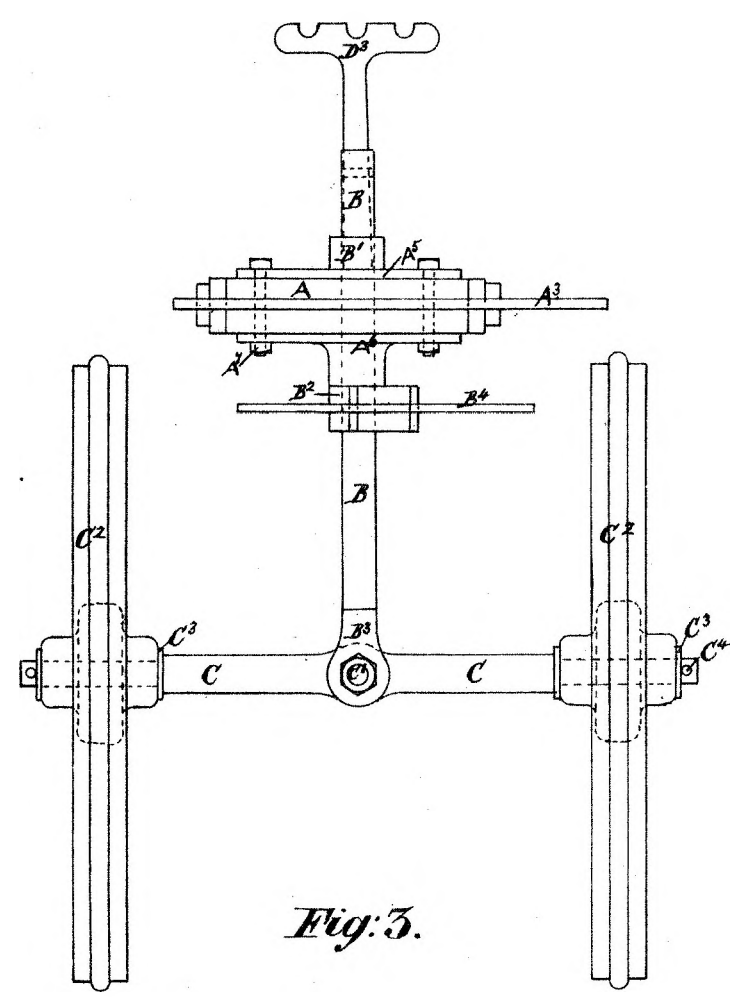


Fig. 3.

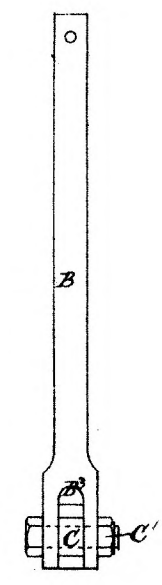


Fig. 4.

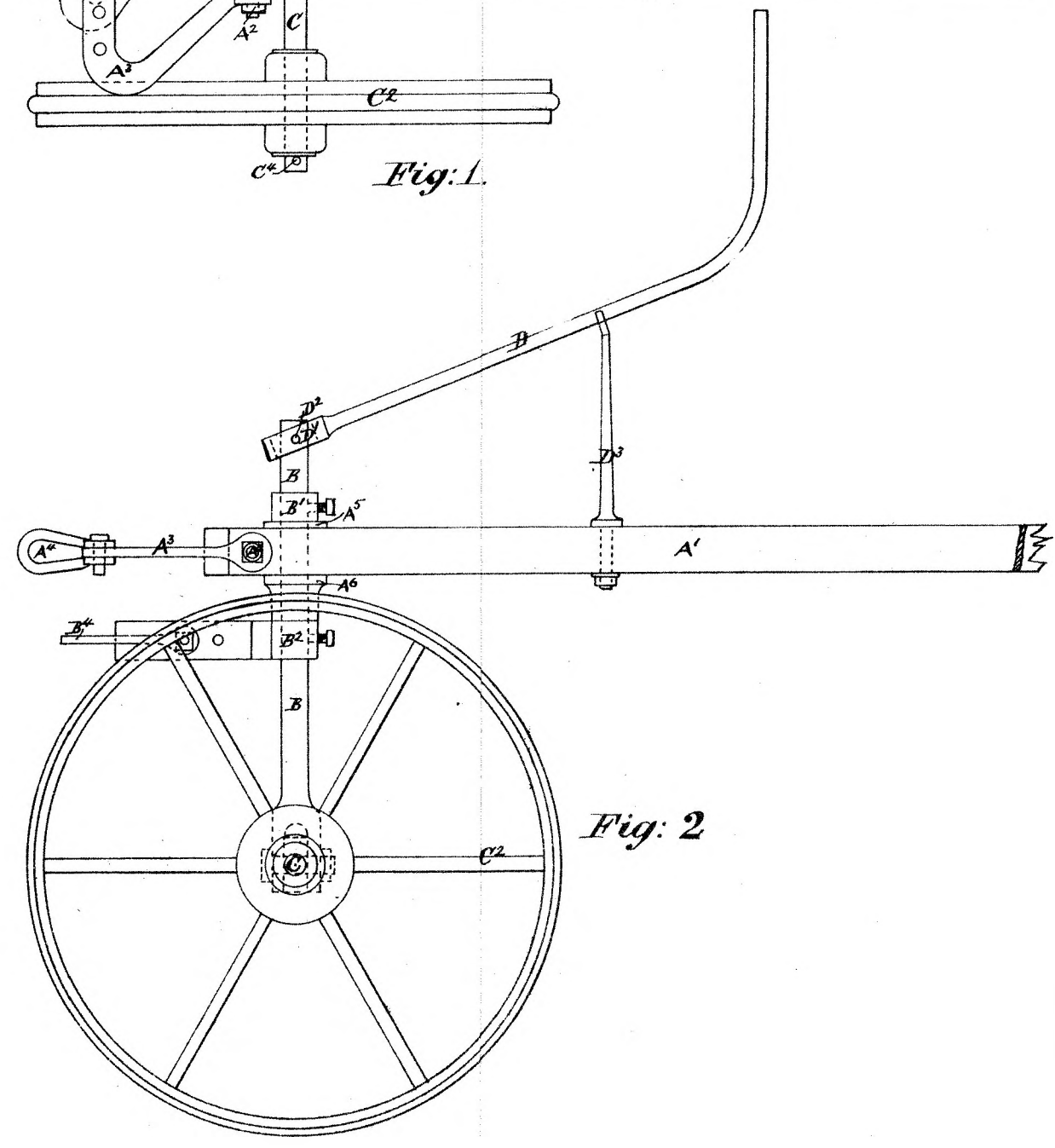
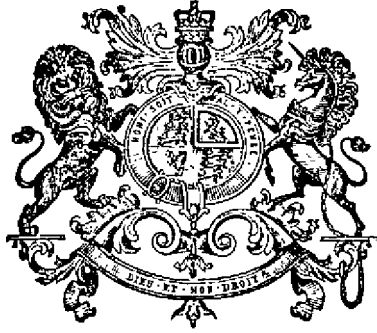


Fig. 2.

This is the Sheet of Drawings referred to in the annexed
 Letters of Registration, granted to James Morrow, the
 twentysecond day of September, A.D. 1884.
 Augustus Loftus.

PHOTO-LITHOGRAPHED AT THE GOVT. PRINTING OFFICE,
 SYDNEY, NEW SOUTH WALES.

(sig 245-)



A.D. 1884, 22nd September. No. 1508.

IMPROVEMENTS IN WIRE CABLES FOR HAULAGE AND LIKE PURPOSES.

LETTERS OF REGISTRATION to Thomas Seale and Franz Carl Guilleaume,
for Improvements in Wire Cables for Haulage and like purposes.

[Registered on the 23rd day of September, 1884, in pursuance of the Act 16 Vic. No. 24.]

BY HIS EXCELLENCY THE RIGHT HONORABLE SIR AUGUSTUS WILLIAM FREDERICK SPENCER LOFTUS
(commonly called LORD AUGUSTUS LOFTUS), Knight Grand Cross of the Most Honorable Order of the
Bath, a Member of Her Majesty's Most Honorable Privy Council, Governor and Commander-in-
Chief of the Colony of New South Wales and its Dependencies.

TO ALL TO WHOM THESE PRESENTS SHALL COME, greeting :

WHEREAS THOMAS SEALE, of San Francisco, in the State of California, one of the United States of America, and Franz Carl Guilleaume, trading under the name and style of "Felton and Guilleaume," at Carlswerk, Mulheim a/- Rhine, Germany, wire manufacturers, have by their Petition humbly represented to me that your Petitioner, Thomas Seale, is the author or designer of a certain invention or improvement in manufactures, that is to say, of an invention entitled "Improvements in Wire Cables for Haulage and like purposes," which is more particularly described in the specification and the sheet of drawings which are hereto annexed; and that your Petitioner, Franz Carl Guilleaume, as the said firm of Felton and Guilleaume, is the assignee of the said Thomas Seale, of one-third interest of and in the said invention so far as the said Colony of New South Wales is concerned; and that they, the said Petitioners, have deposited with the Honorable the Treasurer of the said Colony of New South Wales the sum of Twenty Pounds sterling, for defraying the expense of granting these Letters of Registration, as required by the Act of Council, sixteenth Victoria, number twenty-four; and have humbly prayed that I would be pleased to grant Letters of Registration, whereby the exclusive enjoyment and advantage of the said invention or improvement might be secured to them for a period of fourteen years: And I, being willing to give encouragement to all inventions and improvements in the arts or manufactures which may be for the public good, and having received a report favourable to the prayer of the said Petition, from competent persons appointed by me to examine and consider the matters stated therein and to report thereon for my information, am pleased, with the advice of the Executive Council, and in exercise of the power and authority given to me by the said Act of Council, to grant, and do by these Letters of Registration grant unto the said Thomas Seale and Franz Carl Guilleaume, their executors, administrators, and assigns, the exclusive enjoyment and advantage of the said invention or improvement, for and during the term of fourteen years from the date hereof; to have, hold, and exercise unto the said Thomas Seale and Franz Carl Guilleaume, their executors, administrators, and assigns, the exclusive enjoyment and advantage thereof for and during and unto the full end and term of fourteen years from the date of these presents next and immediately ensuing, and fully to be complete and ended: Provided always, that if the said Thomas Seale and Franz Carl Guilleaume shall not, within three days after the granting of these Letters of Registration, register the same in the proper office in the Supreme Court, at Sydney, in the said Colony of New South Wales, then these Letters of Registration, and all advantages whatsoever hereby granted, shall cease and become void.

In witness whereof, I have hereunto set my sign manual, and have caused the present Letters of Registration to be sealed with the seal of the said Colony of New South Wales, at Government House, Sydney, in New South Wales, this twenty-second day of September, in the year of our Lord one thousand eight hundred and eighty-four.

[L.S.]

AUGUSTUS LOFTUS.

SPECIFICATION.

Improvements in Wire Cables for Haulage and like purposes.

SPECIFICATION.

TO ALL TO WHOM THESE PRESENTS SHALL COME: I, FRANZ CARL GUILLEAUME, of the firm of Felton and Guillaume, of Carlswerk, Mulheim a/- Rhine, in the Empire of Germany, wire manufacturer, send greeting:

WHEREAS I, the said Franz Carl Guillaume, am the assignee of one-third interest in certain "Improvements in Wire Cables for Haulage and like purposes," devised by Thomas Seale, of San Francisco:

Now KNOW YE that I, the said Franz Carl Guillaume, do hereby declare the nature of the said improvements, and in what manner the same are to be performed to be particularly described and ascertained in and by the following statement, that is to say:—

The object of this invention is to produce wire cables, suitable for haulage, traction, and similar purposes (as distinguished from telegraphic purposes), in which a high degree of flexibility in conjunction with the requisite strength is obtained, whilst the durability is increased as compared with cables manufactured according to the methods hitherto adopted.

A cable constructed according to this invention is formed of several strands, each of which consists of a central core composed of a considerable number of fine wires, these being enveloped in a wrapping or covering composed of wire several sizes thicker in gauge. A strand constructed in such a manner possesses great flexibility on account of the main body thereof consisting of fine wire. It also possesses great strength relatively to its sectional area, as the fine wires pack very closely together. Further, the central core presents a comparatively smooth surface for the covering wires to be wrapped upon. Moreover, there is less tendency to crystallization in the material forming the main body of the strand; hence the durability thereof is considerably improved.

In manufacturing wire cables for purposes described, it has hitherto been a common practice to twist together seven wires of a gauge determined and regulated by the size of the rope or cable to be produced, twisting machinery being employed to effect this. By similar means a number of wires of the same gauge are then laid around this core, and form a covering therefor. Several strands formed in this manner are afterwards twisted together, and constitute the cable.

Now, this method of manufacture, although fairly well adapted for standing cables, is defective when applied to cables for haulage and similar purposes. In such applications cables are generally required to pass round drums or sheaves or between gripping devices, the consequent and frequent flexion or compression and attendant crystallization rapidly destroying the cores or main bodies of the strands, and rendering the whole cable unserviceable.

The accompanying drawings represent a cable constructed according to this invention, fig. 1 being a side elevation, showing one of the strands partially unwound and unwrapped, and fig. 2 being a transverse section. In the present example the cable is composed of six strands, but this number is not of essential importance.

In manufacturing a cable according to this invention, I proceed substantially as follows:—By means of wire rope twisting machinery of the kind suitable for the purpose, I form a core *a* by twisting together a number of wires of finer gauge than those to be employed for the cover or wrapping of the strand. I then surround this core with a firm cylindrical envelope of wires *a'*, these being also of the finer gauge. The main body of the strand being now constituted, I apply thereto a wrapping or protective covering of coarse wire *b*.

In constructing a six-strand cable of 1½ inches diameter, I have employed wires of the size No. 17½ (Birmingham wire gauge) for the main body and wires of the size No. 13½ for the covering, with advantageous results. I desire it to be understood, however, that I do not limit myself to these or any precise proportions between the two grades of wire employed, as, under certain circumstances, it might be expedient to vary the same to a moderate extent. For example, to increase the flexibility of the cable, the size of the body wires should be somewhat reduced.

To complete the cable, a number of strands formed in the manner described are twisted together and around a core *c* usually composed of hemp, and the cable is ready for use.

I am aware that cables intended for the purposes described have been constructed with a soft, flexible core of hemp in the centre of each strand and in the centre of the cable between the strands. Such cables have, however, but little durability, on account of the metallic portion intended to withstand the strain being disposed about the exterior of the strand, where it is subjected to abrasion and extreme variations of tension and compression.

I am also aware that cables of the kind alluded to have been produced having strands each containing cores composed of as many as seven wires, these being of the same or approximately the same gauge as that of the covering wires. Such cables, however, neither realize the objects of the present invention, nor possess the practical advantages resulting from its use.

Having thus described the nature of the said invention, and in what manner the same is to be performed, as communicated to me by my foreign correspondents, I claim—

Constructing wire cables, for haulage and like purposes, of strands twisted together, each of these being composed of a main body of numerous fine wires wrapped with a protective covering of coarser wires, substantially as described.

And I do, for myself, my heirs, executors, and administrators, covenant with Her Majesty, Her Heirs, and Successors, that I believe the said invention to be a new invention as to the public use and exercise thereof, and that I do not know or believe that any person or persons, other than the said Thomas Seale, is the true and first inventor of the said invention, and that I will not deposit these presents at the office of the Registrar-General with any such knowledge or belief as last aforesaid.

Signed by the author or designer, Thomas Seale, this fifth day of May, one thousand eight hundred and eighty-four.

THOMAS SEALE,

(By his Agent, FRED. WALSH).

This is the specification referred to in the annexed Letters of Registration granted to Thomas Seale and Franz Carl Guillaume, the twenty-second day of September, A.D. 1884.

AUGUSTUS LOFTUS.

REPORT.

Improvements in Wire Cables for Haulage and like purposes.

REPORT.

Sir, Sydney, 5 March, 1884.
In reply to your B.C. of 26th ultimo, forwarding for our report the Petition from Messrs. Seale and Guillaume, for Letters of Registration for an invention entitled "Improvement in Wire Cables for Haulage and like purposes," we have the honor, after examination of the plan and specification accompanying the Petition, to recommend that Letters of Registration be issued for the invention referred to.

We have, &c.,
JOHN WHITTON.
E. O. MORIARTY.

The Under Secretary of Justice.

[Drawings—one sheet.]

Fig. 1.

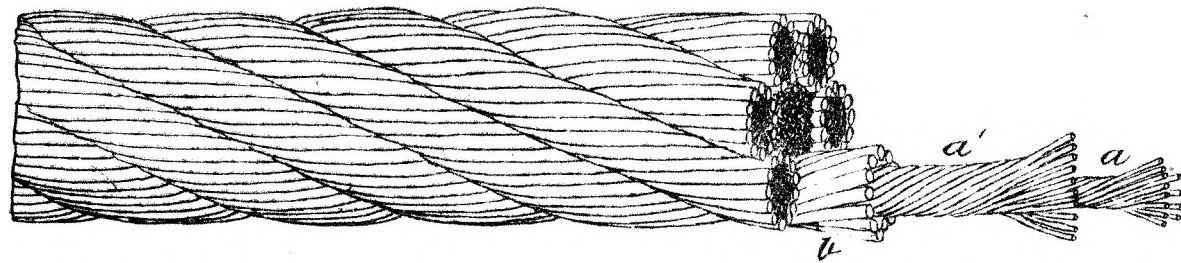
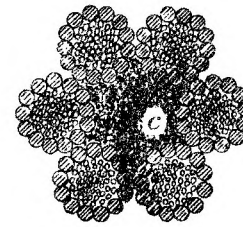


Fig. 2.



*This is the Sheet of Drawings referred to in the
annexed Letters of Registration, granted to Thomas
Seale, and Franz Carl Guilleaume, the twenty second
of September, A.D. 1884. Augustus Loftus.*



A.D. 1884, 26th September. No. 1509.

AN IMPROVED FIRE-BAR.

LETTERS OF REGISTRATION to Joseph Walker, for an improved Fire-bar.

[Registered on the 27th day of September, 1884, in pursuance of the Act 16 Vic. No. 24.]

BY HIS EXCELLENCY THE RIGHT HONORABLE SIR AUGUSTUS WILLIAM FREDERICK SPENCER LOFTUS (commonly called LORD AUGUSTUS LOFTUS), Knight Grand Cross of the Most Honorable Order of the Bath, a Member of Her Majesty's Most Honorable Privy Council, Governor and Commander-in-Chief of the Colony of New South Wales and its Dependencies.

TO ALL TO WHOM THESE PRESENTS SHALL COME, greeting:

WHEREAS JOSEPH WALKER, of the locomotive-engine sheds, Williamstown, in the Colony of Victoria, boiler-maker, hath by his Petition humbly represented to me that he is the author or designer of a certain invention or improvement in manufactures, that is to say, of an invention entitled "An Improved Fire-bar," which is more particularly described in the specification and the sheet of drawings which are hereunto annexed; and that he, the said Petitioner, hath deposited with the Honorable the Treasurer of the said Colony of New South Wales the sum of Twenty Pounds sterling, for defraying the expense of granting these Letters of Registration, as required by the Act of Council, sixteenth Victoria, number twenty-four; and hath humbly prayed that I would be pleased to grant Letters of Registration, whereby the exclusive enjoyment and advantage of the said invention or improvement might be secured to him for a period of fourteen years: And I, being willing to give encouragement to all inventions and improvements in the arts or manufactures which may be for the public good, and having received a report favourable to the prayer of the said Petition, from competent persons appointed by me to examine and consider the matters stated therein and to report thereon for my information, am pleased, with the advice of the Executive Council, and in exercise of the power and authority given to me by the said Act of Council, to grant, and do by these Letters of Registration grant unto the said Joseph Walker, his executors, administrators, and assigns, the exclusive enjoyment and advantage of the said invention or improvement, for and during the term of fourteen years from the date hereof; to have, hold, and exercise unto the said Joseph Walker, his executors, administrators, and assigns, the exclusive enjoyment and advantage thereof, for and during and unto the full end and term of fourteen years from the date of these presents next and immediately ensuing, and fully to be complete and ended: Provided always, that if the said Joseph Walker shall not, within three days after the granting of these Letters of Registration, register the same in the proper office in the Supreme Court, at Sydney, in the said Colony of New South Wales, then these Letters of Registration, and all advantages whatsoever hereby granted, shall cease and become void.

In witness whereof, I have hereunto set my sign manual, and have caused the present Letters of Registration to be sealed with the seal of the said Colony of New South Wales, at Government House, Sydney, in New South Wales, this twenty-sixth day of September, in the year of our Lord one thousand eight hundred and eighty-four.

[L.S.]

AUGUSTUS LOFTUS.

An Improved Fire-bar.

SPECIFICATION of JOSEPH WALKER, of the locomotive-engine sheds, Williamstown, in the Colony of Victoria, boiler-maker, for an invention entitled "An Improved Fire-bar."

My invention consists of an improved fire-bar designed to prevent the formation of clinkers, and to provide a sufficient supply of air to the fire.

My fire-bar has a flat surface, through which I make a double series of oblong slots, each of which leads into a space between two of the ribs on the lower side. This lower side is divided into two parts by a central longitudinal ridge which forms the lowest portion of the bar, and each of these parts are again subdivided by cross ribs. These ribs have a curved face or edge, the lowest point of the curve being that which joins the ridge. The ridge itself descends gradually from each end to the centre, where it reaches its lowest point.

Fire-bars so constructed are placed side by side as many as may be required to fit the furnace,

Referring to my drawings, figures 1, 2, and 3 show respectively top, side, and bottom views of my fire-bar. Figure 4, end view, and figure 5 section at *ab* in figure 1. *AA* are the oblong slots leading into spaces *BB* between the ribs *CC*. *D* is the longitudinal ridge from end to end.

Having thus described the nature of my invention and the manner of performing same, I would have it understood that what I believe to be new, and therefore claim, is—

My improved fire-bar, having a flat surface, in which are slots leading into spaces between the ribs, and having a central longitudinal ridge from end to end, substantially as herein described and explained.

In witness whereof, I, the said Joseph Walker, have hereto set my hand and seal, this fifth day of August, one thousand eight hundred and eighty-four.

Witness—

EDWD. WATERS, Melbourne, Patent Agent.

JOSEPH WALKER.

This is the specification referred to in the annexed Letters of Registration granted to Joseph Walker, the 26th day of September, A.D. 1884.

AUGUSTUS LOFTUS.

REPORT.

Sir,

Referring to your B.C. memo. of 7th instant, forwarding Mr. Joseph Walker's petition for Letters of Registration for an invention entitled "An Improved Fire-bar," we have the honor to state that, having examined the plan and specification accompanying the petition, we are of opinion that Letters of Registration may be granted for the invention in question.

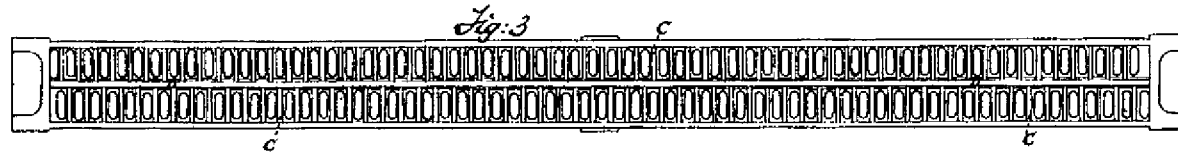
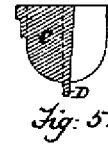
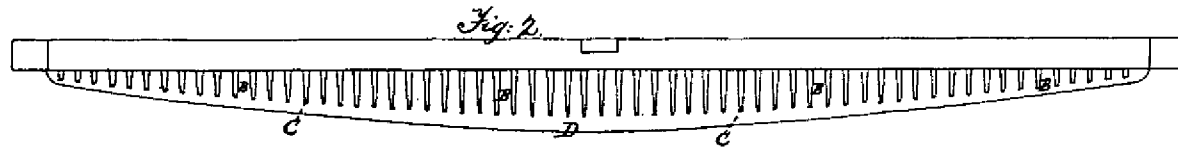
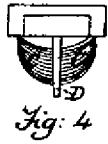
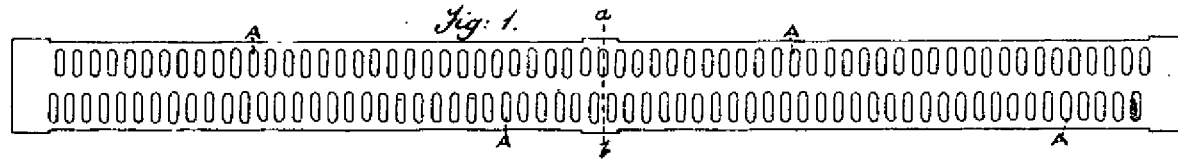
We have, &c.,

JOHN WHITTON.
E. O. MORIARTY.

The Under Secretary of Justice.

[Drawings—one sheet.]

J. WALKER'S PATENT



*This is the Sheet of Drawings referred to in the aforesaid
Letters of Registration granted to Joseph Walker, the
twenty-sixth day of September, A.D. 1884.*

Augustus Loftus.



A.D. 1884, 26th September. No. 1510.

IMPROVED APPARATUS FOR CLEANING DAMS AND TANKS.

LETTERS OF REGISTRATION to Price Williams, for an Improved Apparatus for Cleaning Dams, Tanks, and other Pools of Water, natural or artificial.

[Registered on the 27th day of September, 1884, in pursuance of the Act 16 Vic. No. 24.]

BY HIS EXCELLENCY THE RIGHT HONORABLE SIR AUGUSTUS WILLIAM FREDERICK SPENCER LOFTUS (commonly called LORD AUGUSTUS LOFTUS), Knight Grand Cross of the Most Honorable Order of the Bath, a Member of Her Majesty's Most Honorable Privy Council, Governor and Commander-in-Chief of the Colony of New South Wales and its Dependencies.

TO ALL TO WHOM THESE PRESENTS SHALL COME, greeting :

WHEREAS PRICE WILLIAMS, of Franklin-street West, in the city of Melbourne, and Colony of Victoria, engineer, hath by his Petition humbly represented to me that he is the author or designer of a certain invention or improvement in manufactures, that is to say, of an invention entitled "An Improved Apparatus for Cleaning Dams, Tanks, and other Pools of Water, natural or artificial," which is more particularly described in the specification and the sheet of drawings which are hereunto annexed; and that he, the said Petitioner, hath deposited with the Honorable the Treasurer of the said Colony of New South Wales the sum of Twenty Pounds sterling for defraying the expense of granting these Letters of Registration, as required by the Act of Council, sixteenth Victoria number twenty-four, and hath humbly prayed that I would be pleased to grant Letters of Registration whereby the exclusive enjoyment and advantage of the said invention or improvement might be secured to him for a period of fourteen years: And I, being willing to give encouragement to all inventions and improvements in the arts or manufactures which may be for the public good, and having received a report favourable to the prayer of the said Petition from competent persons appointed by me to examine and consider the matters stated therein and to report thereon for my information, am pleased, with the advice of the Executive Council, and in exercise of the power and authority given to me by the said Act of Council, to grant, and do by these Letters of Registration grant unto the said Price Williams, his executors, administrators, and assigns, the exclusive enjoyment and advantage of the said invention or improvement, for and during the term of fourteen years from the date hereof; to have, hold, and exercise unto the said Price Williams, his executors, administrators, and assigns, the exclusive enjoyment and advantage thereof for and during and unto the full end and term of fourteen years from the date of these presents next and immediately ensuing, and fully to be complete and ended: Provided always, that if the said Price Williams shall not, within three days after the granting of these Letters of Registration, register the same in the proper office in the Supreme Court, at Sydney, in the said Colony of New South Wales, then these Letters of Registration, and all advantages whatsoever hereby granted, shall cease and become void.

In witness whereof, I have hereunto set my sign manual, and have caused the present Letters of Registration to be sealed with the seal of the said Colony of New South Wales, at Government House, Sydney, in New South Wales, this twenty-sixth day of September, in the year of our Lord one thousand eight hundred and eighty-four.

[L.S.]

AUGUSTUS LOFTUS.

An Improved Apparatus for Cleaning Dams and Tanks.

SPECIFICATION of PRICE WILLIAMS, of Franklin-street West, in the city of Melbourne, and Colony of Victoria, engineer, for an invention entitled "An Improved Apparatus for Cleaning Dams, Tanks, and other Pools of Water, natural or artificial."

My invention has been designed mainly for the purpose of removing the mud and other refuse from dams and the earth water-tanks which are commonly in use in Australia for conserving water; but it is also applicable to the removal of mud and other refuse from swampy ground, and from pools of water, natural or artificial.

My apparatus consists of a scoop attached to an endless chain which travels backwards and forwards, carrying the scoop with it. When it travels backwards it carries the scoop to the point at which it is intended to commence to scoop; and when it travels forwards it brings with it the scoop, which gradually fills, and as it approaches the bank is guided by planks up an incline, and when raised sufficiently high is tipped into a shoot leading to any required point. This endless chain is geared to a toothed chain wheel which is driven by any suitable mechanism from one side of the dam or tank by any suitable motive power, and as a rule will reach to a strong portable support on the opposite side, although it is not necessary that it should reach quite across, as the support need not be on the land, but may be floating, and of course anchored in any convenient position.

Referring to my drawing—Fig. 1 shows a longitudinal elevation of my apparatus in working position at a water-tank or dam; fig. 2, a plan of the driving mechanism; fig. 3, a plan of the portable support for the further end of the chain; fig. 4, a plan of the mechanism employed to stop and tip the scoop; and figures 5, 6, and 7, side view, end view, and plan respectively of the scoop or drag which I employ.

A is the water-tank or dam, and A¹ the mud or silt at its bottom. B is the endless chain fastened as shown to the scoop C, and driven by the suitably toothed or recessed chain sheave B¹, the other end of said chain working and being supported on pulley B², which is attached to a shackle and hooked on to one of the eyes B³, secured to the portable support B⁴ mounted on wheels as shown. D is the shaft on which is keyed the chain sheave B¹ and spur wheel D¹. D² are its bearings secured to the framing E, which also supports the bearings D³ in which the shaft D⁴ works, and which shaft has on it the spur pinion D⁶, fast pulley D⁵, and loose pulleys D⁷ and D⁸. E¹ and E² are the driving belts, the latter being crossed for reversing the motion, and both being driven by the wide pulley D⁹ on the shaft of the portable engine F. E³ and E⁴ are the slides and their hand levers or draw-bars for controlling the belts, and E⁵ is the lever pivoted to the cross bar E⁶ and worked by the pin on the parallel bar E⁸, which is forced forward by the frame of the scoop as it nears the end of its travel, and so transfers the driving belt on to the loose pulley and stops the scoop, thus allowing it time to deliver its contents into the shoot E⁷. E⁹ E¹⁰ are the converging pieces for compressing the ends of the spring catches to allow the scoop to tip. G is the inclined frame, having the guides G¹ thereon, which are rounded outwards at their lower end as shown. G² is the lower slide placed in the tank. The scoop C is partly perforated and made of the form shown, and is pivoted at C¹ C¹ to the frame C² which has the lower slide frames C³ C³ secured to it. C⁴ C⁴ are the side catches, compressed inwards into the notches C⁵ C⁵ by the springs C⁶ C⁶. C⁷ is a transverse roller on which the upper half of the chain rests. The chains are affixed to the scoop by the shackles and short chains B⁶ in the manner shown.

My alternative method of supporting the end of the chain when it is not desirable for it to span the whole width of the dam is also shown in fig. 1, where it will be seen that I make it in the form of a raft or float H, having the vertical standard H¹ secured thereto and fitted with eyes as before. This raft may be secured to the bank by guys or stays H², or by any other convenient means for anchoring it.

The operation of my apparatus is as follows:—Motion is imparted to the pulleys on shaft D⁴ by belts from a pulley such as I have shown on a portable engine, or by any other means that may be preferred for giving the necessary motion, such for instance as a "horse-works." The belt E² which drives the machine, so as to take the scoop C out to its starting position, is placed on the fast pulley D⁵, and immediately the operator sees that the scoop is at the desired position in the dam he reverses the motion by placing the other belt E¹ on the fast pulley, and the scoop is brought back loaded with mud or silt to its tipping position, where its spring catches C⁴ are released, and the belt thrown on to the loose pulley and so stopping it, and also preventing any possibility of its being over-wound. After the scoop has been tipped and its contents discharged the motion is reversed and the scoop taken back to its scooping position as before and the operation repeated. The mud, &c., discharged from the scoop is conducted by means of troughs or launders to any required position.

Having thus described the nature of my said apparatus for cleaning dams, tanks, and other pools of water, natural or artificial, I would have it understood that what I believe to be new, and therefore claim as of my invention, is—

First—The combination of a scoop, chain travelling to and fro, with a driving mechanism at one end and a support at the other, floating or otherwise, and preferably with a chain pulley to work said chain, all substantially as herein described and explained, and as illustrated in my drawings.

Second—The combination of the outer frame and skids with the scoop, substantially as described.

Third—The combination of the contrivances for releasing and tipping the scoop, and for automatically shifting the driving belt on to the loose pulley at the required moment, substantially as described.

In witness whereof, I, the said Price Williams, have hereto set my hand and seal, this first day of August, one thousand eight hundred and eighty-four.

Witness—

EDWD. WATERS, Melbourne, Patent Agent.

PRICE WILLIAMS.

This is the specification referred to in the annexed Letters of Registration granted to Price Williams, the twenty-sixth day of September, A.D. 1884.

AUGUSTUS LOFTUS.

REPORT.

An Improved Apparatus for Cleaning Dams and Tanks.

REPORT.

Sir,

The application of Mr. Price Williams for Letters of Registration for an invention entitled "An Improved Apparatus for Cleaning Dams, Tanks, and other Pools of Water, natural or artificial," having been referred to us, we have examined the plans and specification accompanying the same, and have now the honor to report that we see no objection to the issue of Letters of Registration, as prayed for.

Sydney, 21 August, 1884.

We have, &c.,

JAMES BARNET,
EDMUND FOSBERY.

The Under Secretary of Justice.

[Drawings—one sheet.]

—PRICE WILLIAMS' PATENT.—

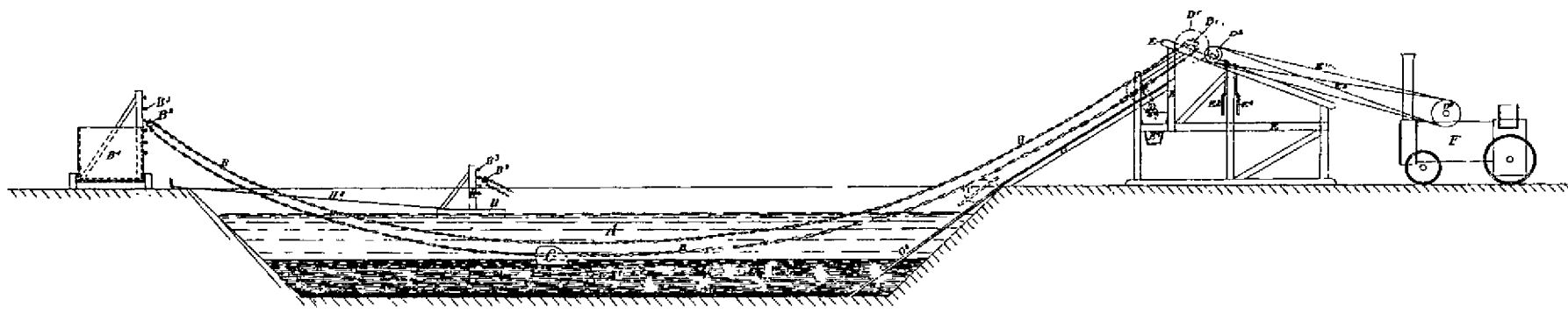


Fig. 1.

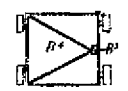


Fig. 3.

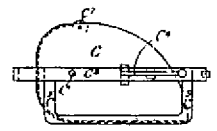


Fig. 5.

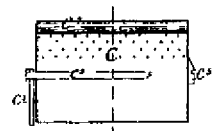


Fig. 6.

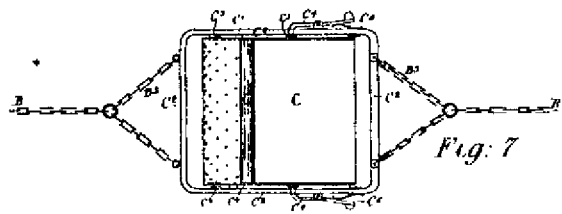


Fig. 7.

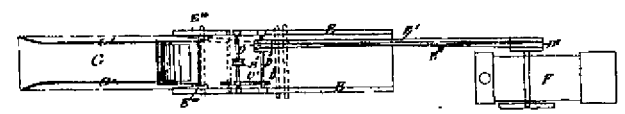


Fig. 2.

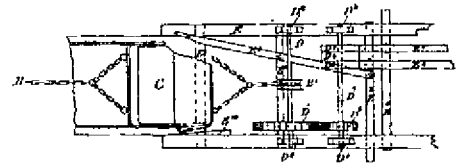


Fig. 4.

PHOTO-LITHOGRAPHED AT THE GOVT. PRINTING OFFICE, SYDNEY, NEW SOUTH WALES.

(Sig 245-)

This is the Sheet of Drawings referred to in the aforesaid Letters of Registration, granted to Price Williams, the twenty sixth day of September, A.D. 1884.

Augustus Loftus.



A.D. 1884, 26th September. No. 1511.

IMPROVEMENTS IN APPLIANCES FOR FILTERING WATER OR OTHER LIQUIDS.

LETTERS OF REGISTRATION to John Perkins Jackson, for Improvements in Appliances for Filtering Water or other Liquids.

[Registered on the 27th day of September, 1884, in pursuance of the Act 16 Vic. No. 24.]

BY HIS EXCELLENCY THE RIGHT HONORABLE SIR AUGUSTUS WILLIAM FREDERICK SPENCER LOFTUS (commonly called LORD AUGUSTUS LOFTUS), Knight Grand Cross of the Most Honorable Order of the Bath, a Member of Her Majesty's Most Honorable Privy Council, Governor and Commander-in-Chief of the Colony of New South Wales and its Dependencies.

TO ALL TO WHOM THESE PRESENTS SHALL COME, greeting:

WHEREAS JOHN PERKINS JACKSON, of Liverpool, in the county of Lancaster, England, wine merchant's engineer, hath by his Petition humbly represented to me that he is the author or designer of a certain invention or improvement in manufactures, that is to say, of an invention entitled "Improvements in Appliances for Filtering Water or other Liquids," which is more particularly described in the specification and the sheet of drawings which are hereunto annexed; and that he, the said Petitioner, hath deposited with the Honorable the Treasurer of the said Colony of New South Wales the sum of Twenty Pounds sterling, for defraying the expense of granting these Letters of Registration, as required by the Act of Council, sixteenth Victoria number twenty-four; and hath humbly prayed that I would be pleased to grant Letters of Registration, whereby the exclusive enjoyment and advantage of the said invention or improvement might be secured to him for a period of fourteen years: And I, being willing to give encouragement to all inventions and improvements in the arts or manufactures which may be for the public good, and having received a report favourable to the prayer of the said Petition, from competent persons appointed by me to examine and consider the matters stated therein and to report thereon for my information, am pleased, with the advice of the Executive Council, and in exercise of the power and authority given to me by the said Act of Council, to grant, and do by these Letters of Registration grant unto the said John Perkins Jackson, his executors, administrators, and assigns, the exclusive enjoyment and advantage of the said invention or improvement, for and during the term of fourteen years from the date hereof; to have, hold, and exercise unto the said John Perkins Jackson, his executors, administrators, and assigns, the exclusive enjoyment and advantage thereof, for and during and unto the full end and term of fourteen years from the date of these presents next and immediately ensuing, and fully to be complete and ended: Provided always, that if the said John Perkins Jackson shall not, within three days after the granting of these Letters of Registration, register the same in the proper office in the Supreme Court, at Sydney, in the said Colony of New South Wales, then these Letters of Registration, and all advantages whatsoever hereby granted, shall cease and become void.

In witness whereof, I have hereunto set my sign manual, and have caused the present Letters of Registration to be sealed with the seal of the said Colony of New South Wales, at Government House, Sydney, in New South Wales, this twenty-sixth day of September, in the year of our Lord one thousand eight hundred and eighty-four.

[L.S.]

AUGUSTUS LOFTUS.

Improvements in Appliances for Filtering Water or other Liquids.

SPECIFICATION.

Improvements in Appliances for Filtering Water or other Liquids.

I, JOHN PERKINS JACKSON, of the Office for Patents, 6, Lord-street, Liverpool, in the county of Lancaster, wine merchant's engineer, do hereby declare the nature of this invention for "Improvements in appliances for filtering water or other liquids," and in what manner the same is to be performed, to be particularly described and ascertained in and by the following statement:—

This invention will be best understood by reference to the accompanying drawings, in which figure 1 is a vertical section of a complete filter suitable for domestic purposes; figure 2 is a vertical section of a pocket filter according to this invention; figure 3 is a plan of figure 2. Like letters represent like parts.

Referring to figure 1, A is the outer case or body of the filter; B is an inner chamber, tapered or conical towards its lower end, and having a groove B¹ all round it, in which the bag C of asbestos cloth or other suitable material may be secured by a cord or equivalent, as shown; B² are openings in the conical end of B, but by preference stop short at B³, so as to leave a small portion through which no liquid can pass. Perforations may be employed instead of the openings, but the latter are preferred.

The conical chamber D hangs inside B. It has a small opening at its point D¹, and an inwardly projecting rim or open diaphragm D² a little way from the point. The action of this filter is as follows:—In the first instance, when liquid is poured into the chamber D, finely-divided filtering materials, such as powdered animal, vegetable, or mineral charcoal (which may also be combined with lime), or paper pulp, is mixed with it, and as it runs through the asbestos cloth or other material it leaves a fine filtering substance in the meshes and upon the surface of the cloth. If the chamber B were perforated all the way to the top the carbonaceous material would not be deposited to the top, and when the filter was subsequently used a portion of the water, if filled up to the top, would pass through without touching the carbonaceous material. It is therefore important to make the upper portion of the chamber with solid walls. Afterwards, the liquid is poured into the chamber D, and strikes upon the rim D², which serves to receive and check the rush of the liquid as it is poured into the filter. It then runs down through the hole D¹ into the lower portion of B, rising in it according to the amount poured in. It is desirable to have the tip of B below the line B³ solid, as otherwise the water or other fluid would soon wear away the filtering material in a direct line with the hole D¹, and thus render the filter useless.

Where the liquid is very foul, the chamber D may be dispensed with, and a portion of B filled with coarse granular charcoal or equivalent.

The various receptacles, A, B, and D, may be made of earthenware, glass, or the like, or of metal, and may be of any convenient shape and size—for instance, round, as shown, or extended like a long trough.

The use of these filters, is, of course, not confined to domestic purposes.

Figures 2 and 3 show the filter arranged for the pocket. The construction and action are similar to that just described, but it is by preference made entirely of metal. B is the top chamber into which the water is poured; A is the chamber into which it precolates through the perforated or open cone B², which is encased in an asbestos bag as before.

This cone is preferably filled with granular charcoal, which is kept in place by the perforated plate E. The chamber A draws off B, so as to serve as a cup. F is a cap or cover to close the chamber B. The shape of this pocket filter can of course be varied.

Having now particularly described and ascertained the nature of my said invention, and in what manner the same is to be performed, I declare that what I claim is—

- 1.—The chamber or funnel D, having a small opening D¹ at its lower end, and the rim or open diaphragm D², substantially as described, and for the purpose specified.
- 2.—The chamber B, with solid walls above and open or perforated below, substantially as and for the purpose set forth and shown in figure 1 of the accompanying drawings.
- 3.—The pocket filter, consisting essentially of the chamber B (perforated or open at B², which is covered with asbestos cloth or equivalent, and filled with granular charcoal or the like, the latter being retained in place by the perforated plate E), and removable cup chamber A, substantially as set forth and shown in figure 2 of the accompanying drawings.

Dated this nineteenth day of June, 1884.

JOHN PERKINS JACKSON.

This is the specification referred to in the annexed Letters of Registration granted to John Perkins Jackson, the twenty-sixth day of September, A.D. 1884.

AUGUSTUS LOFTUS.

REPORT.

Sir,

In reply to your blank cover, transmitting Mr. John Perkins Jackson's Petition for the registration of an invention entitled "Improvements in appliances for filtering water or other liquids," we do ourselves the honor to report that we are of opinion the prayer of the Petitioner may be granted, in terms of his specification, drawings, and claim.

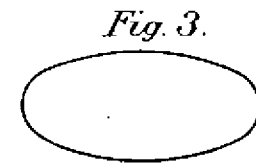
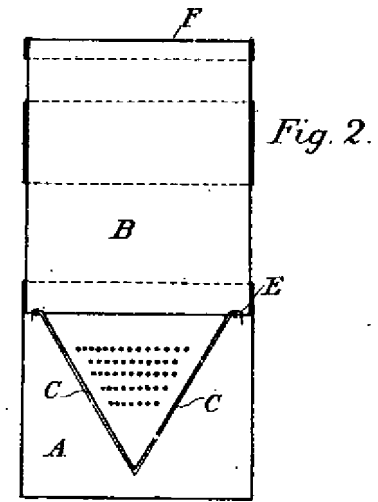
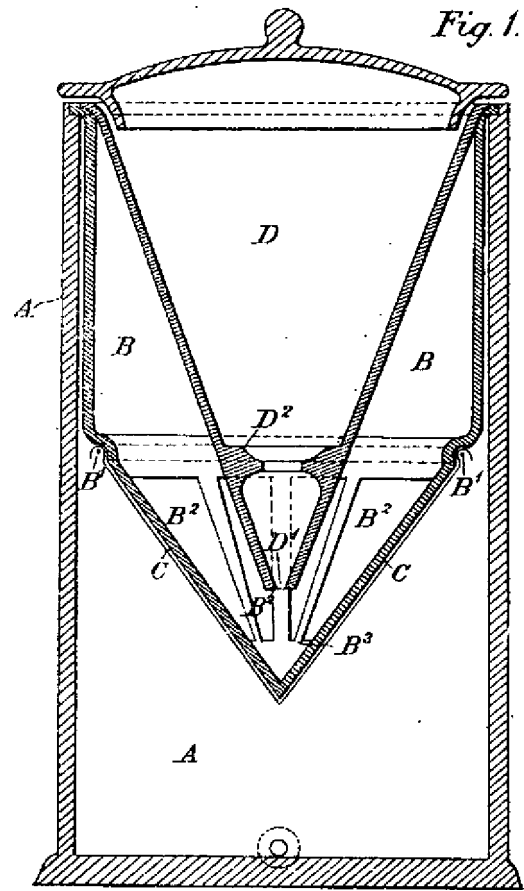
The Under Secretary of Justice.

Sydney, 20 August, 1884.

We have, &c.,

E. C. CRACKNELL.

GOTHER K. MANN.



(Sig 245-)

*This is the Sheet of Drawings referred to in the annexed
Letters of Registration, granted to John Perkin Jackson,
the twenty sixth day of September, A.D. 1884.*

Augustus Loftus.



A.D. 1884, 26th September. No. 1512.

IMPROVEMENTS IN ASTRAGALS OR GLAZING BARS.

LETTERS OF REGISTRATION to William Richard Lester, for Improvements in Astragals or Glazing Bars for holding and securing Glass for Roof Lights and Windows.

[Registered on the 27th day of September, 1884, in pursuance of the Act 16 Vic. No. 24.]

BY HIS EXCELLENCY THE RIGHT HONORABLE SIR AUGUSTUS WILLIAM FREDERICK SPENCER LOFTUS (commonly called LORD AUGUSTUS LOFTUS), Knight Grand Cross of the Most Honorable Order of the Bath, a Member of Her Majesty's Most Honorable Privy Council, Governor and Commander-in-Chief of the Colony of New South Wales and its Dependencies.

TO ALL TO WHOM THESE PRESENTS SHALL COME, greeting :

WHEREAS WILLIAM RICHARD LESTER, of Glasgow, North Britain, hath by his Petition humbly represented to me that he is the author or designer of a certain invention or improvement in manufactures, that is to say, of an invention entitled "Improvements in Astragals or Glazing Bars for holding and securing Glass for Roof Lights and Windows," which is more particularly described in the specification and the sheet of drawings which are hereunto annexed ; and that he, the said Petitioner, hath deposited with the Honorable the Treasurer of the said Colony of New South Wales the sum of Twenty Pounds sterling, for defraying the expense of granting these Letters of Registration, as required by the Act of Council, sixteenth Victoria number twenty-four ; and hath humbly prayed that I would be pleased to grant Letters of Registration, whereby the exclusive enjoyment and advantage of the said invention or improvement might be secured to him for a period of fourteen years : And I, being willing to give encouragement to all inventions and improvements in the arts or manufactures which may be for the public good, and having received a report favourable to the prayer of the said Petition, from competent persons appointed by me to examine and consider the matters stated therein and to report thereon for my information, am pleased, with the advice of the Executive Council, and in exercise of the power and authority given to me by the said Act of Council, to grant, and do by these Letters of Registration grant unto the said William Richard Lester, his executors, administrators, and assigns, the exclusive enjoyment and advantage of the said invention or improvement, for and during the term of fourteen years from the date hereof ; to have, hold, and exercise unto the said William Richard Lester, his executors, administrators, and assigns, the exclusive enjoyment and advantage thereof, for and during and unto the full end and term of fourteen years from the date of these presents next and immediately ensuing, and fully to be complete and ended : Provided always, that if the said William Richard Lester shall not, within three days after the granting of these Letters of Registration, register the same in the proper office in the Supreme Court, at Sydney, in the said Colony of New South Wales, then these Letters of Registration, and all advantages whatsoever hereby granted, shall cease and become void.

In witness whereof, I have hereunto set my sign manual, and have caused the present Letters of Registration to be sealed with the seal of the said Colony of New South Wales, at Government House, Sydney, in New South Wales this twenty-sixth day of September, in the year of our Lord one thousand eight hundred and eighty-four.

[L.S.]

AUGUSTUS LOFTUS.

Improvements in Astragals or Glazing Bars.

SPECIFICATION of WILLIAM RICHARD LESTER, of Glasgow, North Britain, engineer, for an invention entitled "Improvements in Astragals or Glazing Bars for holding and securing Glass for Roof Lights and Windows."

My invention relates to bars for holding and securing glass for roof lights and windows in which the use of putty and paint is avoided, and has for its object the attaining of a stronger astragal or glazing bar than has hitherto been devised in a simple and economical manner.

My improved glazing bar comprises a core, consisting of a rolled bar of iron or steel of T section, with the transverse web straight or curved, such bar being used in an inverted position, and having applied to it two strips of thin sheet lead, which are folded down upon the glass when in position. A sheath of zinc, iron, steel, copper, brass or other metal is applied to the bottom and upper sides of the transverse web, in such a way as to form a support or resting surface for the glass, and also so as to clip and hold the inner edges of the thin lead strips, and resist any force tending to lift the glass and lead.

In the accompanying drawing, in which the parts are shown on an enlarged scale in order to render the small details clear, figure 1 is a transverse section, one form of my improved glazing bar, with the lead strips as they are before the glass is placed in position; figure 2 is a section showing the glass fixed in position; and figure 3 is a section showing another form of the bar forming the core, the glass being shown as in position on only one side, the other side being as manufactured.

In the modification shown in figures 1 and 2, the core A is an iron bar of a plain T section inverted, and it has applied to its bottom web a sheath B of zinc, iron, steel, copper, brass, or other metal, which is extended upwards at the edges of the bottom web of the core, and is doubled to form supports C for the glass D. The part of the sheath which is doubled over inwards to form the supports C is at the same time made to clip the lower or inner edges of the thin lead strips E, and is continued inward at the bottoms F of the insides of the supports C, so as to hold the lead strips close down upon the bottom web of the core.

In the modification shown in figure 3 the bottom web of the core A being curved or having its edges bended upwards, these edges extend up into the parts C of the sheath on which the glass D rests. The sheath B is by preference applied to the bar or core A by drawing them together through suitable dies. In the case of the modification shown in figures 1 and 2 the lead strips E may be first combined with the sheath by being compressed or clipped in the parts, and subsequently the combined sheath and lead strips may be combined with the core by drawing through dies.

Having thus particularly described and ascertained the nature of my said invention, and the manner in which the same is to be performed, I would have it understood that what I believe to be new, and therefore claim as my improvements in astragals or glazing bars for holding and securing glass for roof lights and windows, is only—

The combination and arrangement of the rolled bar or core A with the sheath B C and lead strips D E, substantially as herein described and explained, and as illustrated in the drawings.

In witness whereof, I, the said William Richard Lester, have hereto set my hand and seal, this second day of August, one thousand eight hundred and eighty-four.

W. R. LESTER.

(By His Attorney, JOHN H. GOODLET.)

Witness—

FRED. WALSH,

Manager, Edward Waters' Patent Office, Sydney.

This is the specification referred to in the annexed Letters of Registration granted to William Richard Lester, the twenty-sixth day of September, A.D., 1884.

AUGUSTUS LOFTUS.

REPORT.

Sir,

The application of Mr. William Richard Lester for Letters of Registration for an invention entitled "Improvements in Astragals or Glazing Bars for holding and securing Glass for Roof Lights and Windows," having been referred to us, we have examined the plans and specification accompanying the same, and have now the honor to report that we see no objection to the issue of Letters of Registration as prayed for.

We have, &c.,

JAMES BARNET.

EDMUND FOSBERY.

The Under Secretary of Justice.

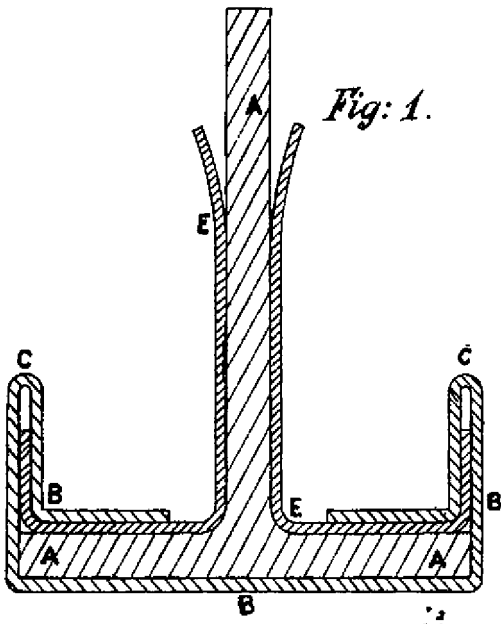


Fig: 1.

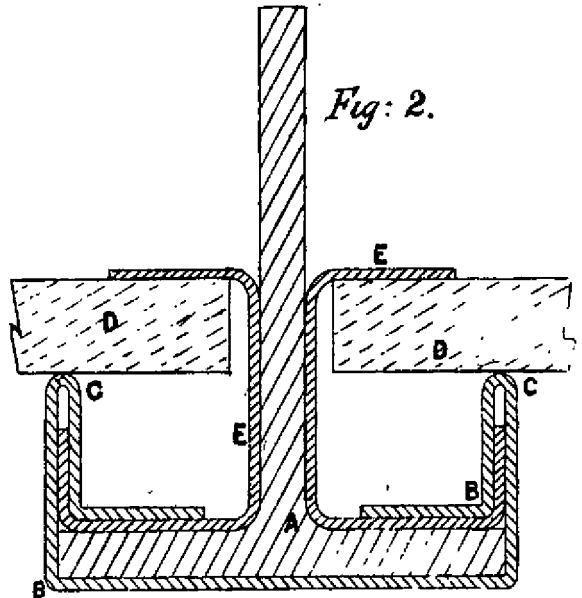


Fig: 2.

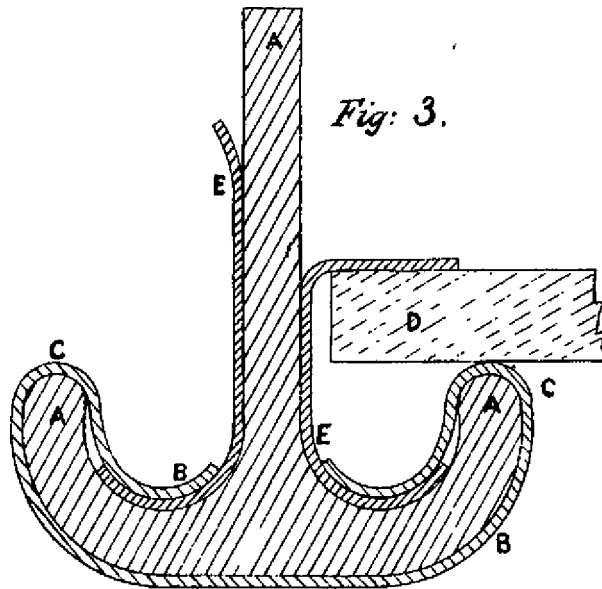


Fig: 3.

Note These figures are shown four times natural size.

This is the Sheet of Drawings referred to in the annexed Letters of Registration granted to William Richard Lester, the twenty sixth day of September, A.D. 1883.

Augustus Loftus.

(Sig 245-)



A.D. 1884, 6th October, No. 1513.

M'DONALD'S EXPANSION ROLLERS.

LETTERS OF REGISTRATION to John Alexander M'Donald, for Improvements
in Expansion Rollers.

[Registered on the 7th day of October, 1884, in pursuance of the Act 16 Vic. No. 21.]

BY HIS EXCELLENCY THE RIGHT HONORABLE SIR AUGUSTUS WILLIAM FREDERICK SPENCER LOFTUS (commonly called LORD AUGUSTUS LOFTUS), Knight Grand Cross of the Most Honorable Order of the Bath, a Member of Her Majesty's Most Honorable Privy Council, Governor and Commander-in-Chief of the Colony of New South Wales and its Dependencies.

TO ALL TO WHOM THESE PRESENTS SHALL COME, greeting:

WHEREAS JOHN ALEXANDER M'DONALD, of the city of Sydney, in the Colony of New South Wales, civil engineer, hath by his petition humbly represented to me that he is the author or designer of a certain invention or improvement in manufactures, that is to say, of an invention of "Improvements in Expansion Rollers, entitled 'M'Donald's Expansion Rollers,'" which is more particularly described in the specification and the sheet of drawings which are hereunto annexed; and that he, the said Petitioner, hath deposited with the Honorable the Treasurer of the said Colony of New South Wales the sum of Twenty Pounds sterling, for defraying the expense of granting these Letters of Registration, as required by the Act of Council, sixteenth Victoria, number twenty-four; and hath humbly prayed that I would be pleased to grant Letters of Registration, whereby the exclusive enjoyment and advantage of the said invention or improvement might be secured to him for a period of fourteen years: And I, being willing to give encouragement to all inventions and improvements in the arts or manufactures which may be for the public good, and having received a report favourable to the prayer of the said Petition, from competent persons appointed by me to examine and consider the matters stated therein and to report thereon for my information, am pleased, with the advice of the Executive Council, and in exercise of the power and authority given to me by the said Act of Council, to grant, and do by these Letters of Registration grant unto the said John Alexander M'Donald, his executors, administrators, and assigns, the exclusive enjoyment and advantage of the said invention or improvement, for and during the term of fourteen years from the date hereof; to have, hold, and exercise unto the said John Alexander M'Donald, his executors, administrators, and assigns, the exclusive enjoyment and advantage thereof, for and during and unto the full end and term of fourteen years from the date of these presents next and immediately ensuing, and fully to be complete and ended: Provided always, that if the said John Alexander M'Donald shall not, within three days after the granting of these Letters of Registration, register the same in the proper office in the Supreme Court, at Sydney, in the said Colony of New South Wales, then these Letters of Registration, and all advantages whatsoever hereby granted, shall cease and become void.

In witness whereof, I have hereunto set my sign manual, and have caused the present Letters of Registration to be sealed with the seal of the said Colony of New South Wales, at Government House, Sydney, in New South Wales, this sixth day of October, in the year of our Lord one thousand eight hundred and eighty-four.

[L.S.]

AUGUSTUS LOFTUS.

M' Donald's Expansion Rollers.

TO ALL TO WHOM THESE PRESENTS SHALL COME: I, JOHN ALEXANDER M'DONALD, of the city of Sydney, in the Colony of New South Wales, civil engineer, send greeting:

WHEREAS I am desirous of obtaining Letters of Registration for securing unto me Her Majesty's special license, that I, my executors, administrators, and assigns, and such others as I or they shall at any time agree with and no others, shall and lawfully may from time to time, and at all times during the term of fourteen years from the day on which this instrument shall be left at the office of the Minister of Justice, Sydney, make, use, exercise, and vend within the Colony of New South Wales, an invention of "Improvements in Expansion Rollers, entitled 'M'Donald's Expansion Rollers,'" for allowing expansion from heat or movement from other causes in structures, or iron, steel, or any other material, as more particularly described in the following specification and accompanying plans:—

SPECIFICATION.

My invention relates to the application of a new form of roller for allowing of expansion from heat or movement from other causes in structures of iron or any other material, particularly in allowing of expansion and contraction from heat, in bridges, arches, viaducts, aqueducts, pipes, and other structures.

These rollers are a section of a cylinder of the form shown in the drawings, having the two curved faces turned or shaped to a radius equal to half the diameter of the roller, and the other two faces flat; or in many cases the two flat faces may be recessed or cored in any manner convenient to decrease the weight of the roller.

They are placed either singly or in groups under the bearing-plate or saddle of any structure, in a somewhat similar manner to the usual arrangement with ordinary cylindrical rollers of small dimension. If necessary the rollers in each group are connected together by links. In many cases it may be found more convenient to have those rollers working in a box or frame or sunk in masonry. It will often be advantageous to have a shoulder or groove on the circumference of the roller with a corresponding groove or shoulder on the bearing-plates to prevent any side movement of the structure due to wind-pressure or any other cause.

The advantage of my roller over any other expansion rollers is that the face of my roller having a larger radius than is possible in the ordinary cylindrical rollers the bearing and bed-plates do not become crushed on the lines of pressure, and a slight variation in temperature will cause my rollers to revolve, thus obviating the risk of large structures being unduly strained by an increase of temperature through the rollers having bedded themselves in the bearing and bed plates.

With my rollers the rolling friction or crushing action on the rollers and bearing and bed plates can be reduced to a minimum by the rollers being made of as large a diameter as is most suited to their specific purpose.

The advantage of my rollers also over any arrangement of links or rockers is that the plane of section is never elevated or depressed, but the distance between the bearing and bed plates is absolutely maintained.

For bridges generally these rollers may be from 1 foot 6 inches to 2 feet 6 inches diameter, the width of the face may be slightly in excess of the maximum amount of expansion required, and the length and number of the rollers required may be decided by allowing about 1 ton in every linear inch of gross length of rollers.

I wish it to be distinctly understood that I do not bind myself to these dimensions or proportions in any way whatever, as they will vary on different spans and for various forms of structure.

The rollers may be made of any suitable metal or combination of metals or materials, but will be generally made of cast iron.

Having thus fully described my said invention, and some of the practical applications and advantages of the same, I wish it understood that I claim—

CLAIM.

The peculiar form of the roller shown in the accompanying plans, and substantially described and set forth in the specification as my true design and invention.

2, Wentworth Court, Sydney, 12 July, 1884.

JOHN A. M'DONALD.

This is the specification referred to in the annexed Letters of Registration granted to John Alexander M'Donald, the 6th day of October, A.D. 1884.

AUGUSTUS LOFTUS.

REPORT.

Sir,

Sydney, 28 August, 1884.

Referring to your B.C. of the 12th instant, forwarding a Petition from Mr. J. A. M'Donald, for Letters of Registration for an invention of "Improvements in Expansion Rollers, entitled 'M'Donald's Expansion Rollers,'" we have the honor to state that having examined the plan and specification accompanying the petition, we are of opinion that Letters of Registration may be issued to the petitioner, in terms of the prayer of the petition.

We have, &c.,

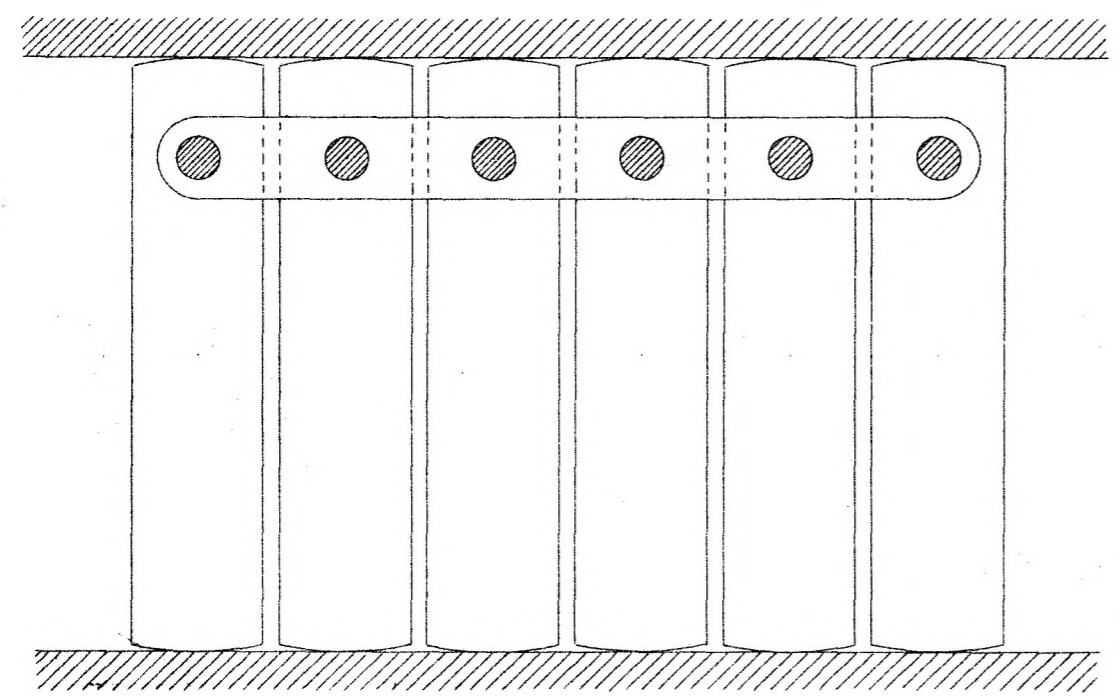
JOHN WHITTON.
E. O. MORIARTY.

The Under Secretary of Justice.

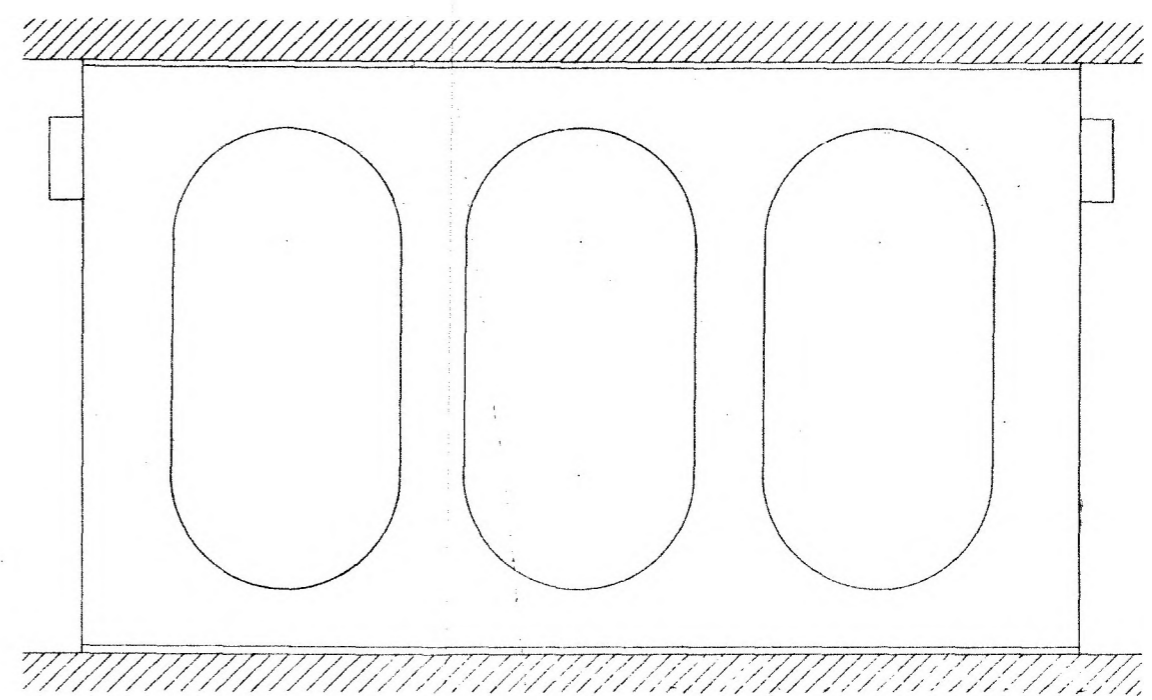
[Drawings—one sheet.]

*This is the Sheet of Drawings referred to in the annexed
Letters of Registration granted to John Alexander McDonald,
the sixth day of October, A.D. 1884.
Augustus Loftus.*

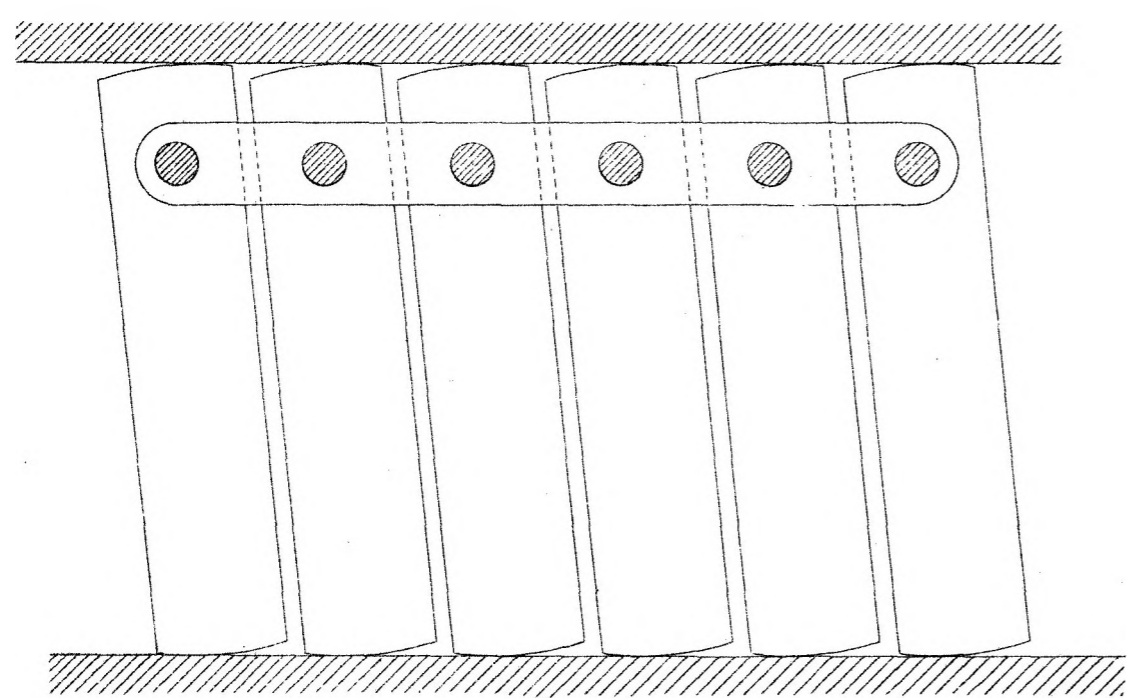
PLAN OF M^C DONALD'S EXPANSION ROLLER



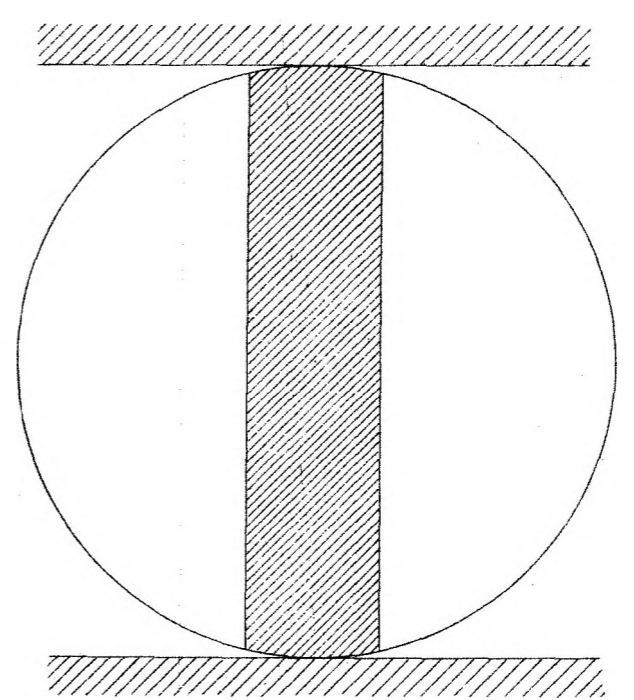
END ELEVATION SHOWING A GROUP OF SIX ROLLERS



SIDE ELEVATION OF ONE ROLLER



END ELEVATION SHOWING POSITION OF ROLLERS AT THEIR MAXIMUM ROLL



END ELEVATION OF ONE ROLLER

*John A. McDonald
Mech. Inst. Wash. Eng. London
Assoc. Mem. Inst. Civil Eng. London
Sydney, Aug. 11th 1884.*

McDonald's Expansion Rollers.

No. 1514.

[Assignment of No. 1325. See Letters of Registration for 1883, page 459.]

No. 1515.

[Assignment of No. 1461. See Letters of Registration for 1884, page 301.]

No. 1516.

[Assignment of No. 1461. See Letters of Registration for 1884, page 301.]



A.D. 1884, 14th October. No. 1517.

**IMPROVEMENTS IN APPARATUS FOR DRYING WASTE ANIMAL MATTERS, FISH,
AND OTHER MATERIALS.**

LETTERS OF REGISTRATION to John Forsyth Johnstone, for Improvements in apparatus for drying waste animal matters, fish, and other materials, applicable also to the concentration of liquids.

[Registered on the 15th day of October, 1884, in pursuance of the Act 16 Vic. No. 24.]

BY HIS EXCELLENCY THE RIGHT HONORABLE SIR AUGUSTUS WILLIAM FREDERICK SPENCER LOFTUS (commonly called LORD AUGUSTUS LOFTUS), Knight Grand Cross of the Most Honorable Order of the Bath, a Member of Her Majesty's Most Honorable Privy Council, Governor and Commander-in-Chief of the Colony of New South Wales and its Dependencies.

TO ALL TO WHOM THESE PRESENTS SHALL COME, greeting:

WHEREAS JOHN FORSYTH JOHNSTONE, of Brooksby Chemical Works, Boro Common Lane, Middlesex, England, hath by his Petition humbly represented to me that he is the author or designer of a certain invention or improvement in manufactures, that is to say, of an invention entitled "Improvements in apparatus for drying waste animal matters, fish, and other materials, applicable also to the concentration of liquids," which is more particularly described in the specification and the sheet of drawings which are hereunto annexed; and that he, the said Petitioner, hath deposited with the Honorable the Treasurer of the said Colony of New South Wales the sum of Twenty Pounds sterling, for defraying the expense of granting these Letters of Registration, as required by the Act of Council sixteenth Victoria, number twenty-four; and hath humbly prayed that I would be pleased to grant Letters of Registration, whereby the exclusive enjoyment and advantage of the said invention or improvement might be secured to him for a period of fourteen years: And I, being willing to give encouragement to all inventions and improvements in the arts or manufactures which may be for the public good, and having received a report favourable to the prayer of the said Petition, from competent persons appointed by me to examine and consider the matters stated therein and to report thereon for my information, am pleased, with the advice of the Executive Council, and in exercise of the power and authority given to me by the said Act of Council, to grant, and do by these Letters of Registration grant unto the said John Forsyth Johnstone, his executors, administrators, and assigns, the exclusive enjoyment and advantage of the said invention or improvement, for and during the term of fourteen years from the date hereof; to have, hold, and exercise unto the said John Forsyth Johnstone, his executors, administrators, and assigns, the exclusive enjoyment and advantage thereof, for and during and unto the full end and term of fourteen years from the date of these presents next and immediately ensuing, and fully to be complete and ended: Provided always, that if the said John Forsyth Johnstone shall not, within three days after the granting of these Letters of Registration, register the same in the proper office in the Supreme Court, at Sydney, in the said Colony of New South Wales, then these Letters of Registration, and all advantages whatsoever hereby granted, shall cease and become void.

In witness whereof, I have hereunto set my sign manual, and have caused the present Letters of Registration to be sealed with the seal of the said Colony of New South Wales, at Government House, Sydney, in New South Wales, this fourteenth day of October, in the year of our Lord one thousand eight hundred and eighty-four.

[L.S.]

AUGUSTUS LOFTUS.

Improvements in apparatus for drying waste animal matters, &c.

SPECIFICATION of JOHN FORSYTH JOHNSTONE, of Brooksby Chemical Works, Bow Common Lane, Middlesex, England, for an invention entitled "Improvements in apparatus for drying waste animal matter, fish, and other materials, applicable also to the concentration of liquids."

My improvements in apparatus for drying all kinds of waste animal matters, fish, or other matter, or for the concentration of liquids, relate to alterations in and additions to the machine known as "Johnstone's drying machine," for which a patent for New South Wales has been granted to me, dated the ninth day of May, one thousand eight hundred and eighty-four.

The object of my alterations in and additions to the abovementioned machine is to enable it to dry or concentrate the materials within it in vacuo.

I construct the steam-jacketed pan of the improved machine or apparatus, together with the agitators and their springs or scrapers and the vertical shaft supporting it, and actuating them all, substantially as described in the specification of the above-mentioned letters patent.

The cover of the machine has hitherto been made of very light material, not capable of withstanding any considerable pressure, and not so constructed and attached to the pan as to completely exclude the ingress or egress of air or vapour.

This light and imperfectly tight cover I replace by one made in one or more parts, securely jointed to the pan and to any brackets within the pan upon which it rests, and sufficiently strong to bear the atmospheric pressure when there is a vacuum within the pan. I prefer to make this cover domed in shape. The vertical shaft of the machine is supported vertically and laterally as heretofore, but where it passes through the cover of the latter is provided with a gland which is to be so packed as to form an air-tight joint. A sufficient space is left between the cover and the worm wheel or other apparatus by means of which the shaft is driven to permit of the withdrawal and packing of the gland. Around the upper part of this gland I provide a vessel or cup surrounding the gland and the shaft, which cup, at the same time, serves as a receptacle for oil or other lubricant and as a further means both of testing and securing the joint.

The cover of the machine is fitted with sight and light glasses and air cock, and is furnished with a man-hole, through which the interior of the pan may be inspected, and the material to be treated may be introduced where the character of this material renders this a convenient way of introducing it. This man-hole is provided with an easily adjusted air-tight lid.

When the material to be treated is of a liquid consistency, the machine is provided with a suitable pipe and cock or valve through which the material may flow into the machine by the action of gravity or otherwise, or be drawn into it by the action of the vacuum created within it.

The vapour generated within the machine is conveyed by a suitable pipe to a condenser, which may be either a surface condenser, a jet condenser, or of other construction. It will in some cases be advantageous to introduce a "save all" between the pan and the condenser. Any material which may boil over in the pan, and which would otherwise pass the condenser and pass away with the condensing water or through the air-pump, will be arrested in the "save-all," and may be returned to the machine.

In some cases an ejector condenser, or a Siemens or Kortings steam jet exhauster, or a jet condenser with Torricellian tube, so arranged and proportioned as to entangle and carry away air with the condensing water, may be used for producing the vacuum, but in most instances it is more convenient to employ a vacuum pump (which may be driven in any convenient way) for this purpose.

The discharge opening passing through the bottom of the pan and of its jacket, through which the finished material drops, has hitherto been closed by a door fitting loosely within it, the upper surface of the door being on the same level as the bottom of the pan, the spaces around the door, between it and the opening, quickly become filled with portions of the solid material contained in the pan, which speedily prevented any considerable leakage of the fluid matters. A door thus constructed could not be made sufficiently tight under vacuum, and accordingly, while retaining the arrangement which makes the upper surface of this door continuous, or nearly so, with the bottom of the pan, I make it tight with a flange joint closing preferably upon india-rubber.

In the drawing hereunto annexed, I have shown apparatus constructed as above described.

Figure 1 is a vertical section, and figure 2 a plan view of the apparatus. Figure 3 is a section taken crosswise through the discharge door which is at the bottom of the pan.

A is the pan of the apparatus surrounded by a steam-jacket B. C is a dome-shaped cover closing over the top of the pan. D is a vertical axis having arms E^r extending from it, which carry scrapers E to scrape over the bottom of the pan. F is a discharge door which closes the discharge outlet formed through the bottom of the pan and the steam-jacket.

The cover C, as above stated, is made sufficiently strong to withstand the pressure of the atmosphere where there is a vacuum within the pan. It is formed with a flange around its edge, to be bolted down on to a corresponding flange formed around the top edge of the pan, so that an air-tight joint may be formed between them. At the centre of the top of the cover is a gland or stuffing box G through which the axis D passes, and which is packed so as to form an air-tight joint around the axis. H is a cup or vessel surrounding the upper part of the gland, to contain oil or other liquid to lubricate the axis, and also indicate whether the packing of the gland is in or out of order.

I is a man-hole formed through the cover and which can be closed air-tight by a lid. The materials to be dried can be fed into the pan through this man-hole. When liquid matters are to be dried up or evaporated the cover might also have a pipe led off from it through which the liquid might be allowed to flow into the pan, JJ are outlet pipes passing from the cover to a "save-all," K, and from there to a condenser L in which a vacuum is maintained. In the drawing, the condensation is effected by a spray of cold water, and the vacuum is maintained in the condenser by means of an air-pump of ordinary construction, but, as before stated, any other ordinary means for maintaining a vacuum might be employed. K^l is a pipe by which any matters arrested in the "save-all" can pass back to the pan. MM are two sight holes formed through the cover; they are glazed with glass so that no air can enter through them. The discharge door F is, as shown at figures 1 and 3, formed with a projecting flange to come against the underside of the steam-jacket. When the door is closed it is pressed upwards by two screws N to force its

Improvements in apparatus for drying waste animal matters, &c.

its flange towards the bottom of the steam-jacket. O is elastic packing placed between the bottom of the steam-jacket and the flange to make an air-tight joint. The screws N screw through arms P, which can be turned on the same axis as the door F, but which are held up as shown at figure 3, when the door is closed. The door is made to turn very loosely upon its axis, so that when closed it may be pressed upwards by turning the screws. R is a worm-wheel fast on the axis D. It is driven continuously by a worm S on a driving shaft T, which is carried in bearings upon the top of the cover, as shown in figure 2, but other ways of giving a continuous revolving motion to the axis might be adopted if desired.

Having now particularly described and ascertained the nature of my said invention, and in what manner the same is to be performed, I declare that what I claim is—

The construction of apparatus such as is described in the specification of the patent already granted to me, and dated the ninth day of May, 1884, in such manner that the pan of the apparatus can be closed air-tight and a vacuum be maintained in it, substantially as described.

In witness whereof, I, the said John Forsyth Johnstone, have hereunto set my hand and seal, this eighteenth day of July, one thousand eight hundred and eighty-four.

JOHN FORSYTH JOHNSTONE.

This is the specification referred to in the annexed Letters of Registration granted to John Forsyth Johnstone, the fourteenth day of October, A.D. 1884.

AUGUSTUS LOFTUS.

REPORT.

Sir,

The application of Mr. John Forsyth Johnstone for Letters of Registration for "Improvements in apparatus for drying waste animal matters, &c.," having been referred to us, we have examined the specification and drawings accompanying the same, and have now the honor to report that we see no objection to the issue of Letters of Registration as prayed for.

Sydney, 5 September, 1884.

We have, &c.,
J. SMITH,
A. LEIBIUS.

The Under Secretary of Justice.

[Drawings—one sheet.]

No. 1518.

[Assignment of No. 991. See Letters of Registration for 1881, page 319.]

Fig. 1.

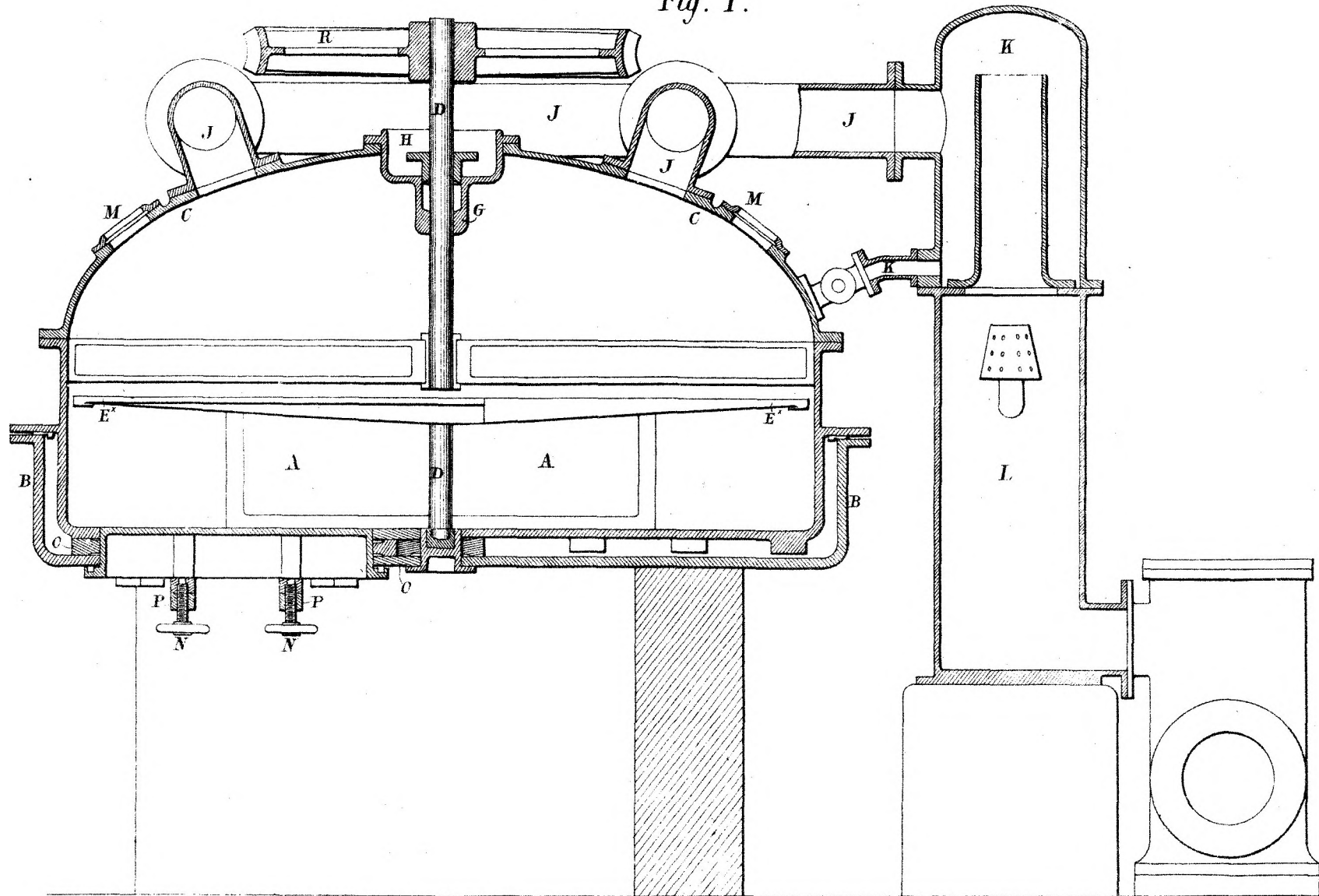


Fig. 2.

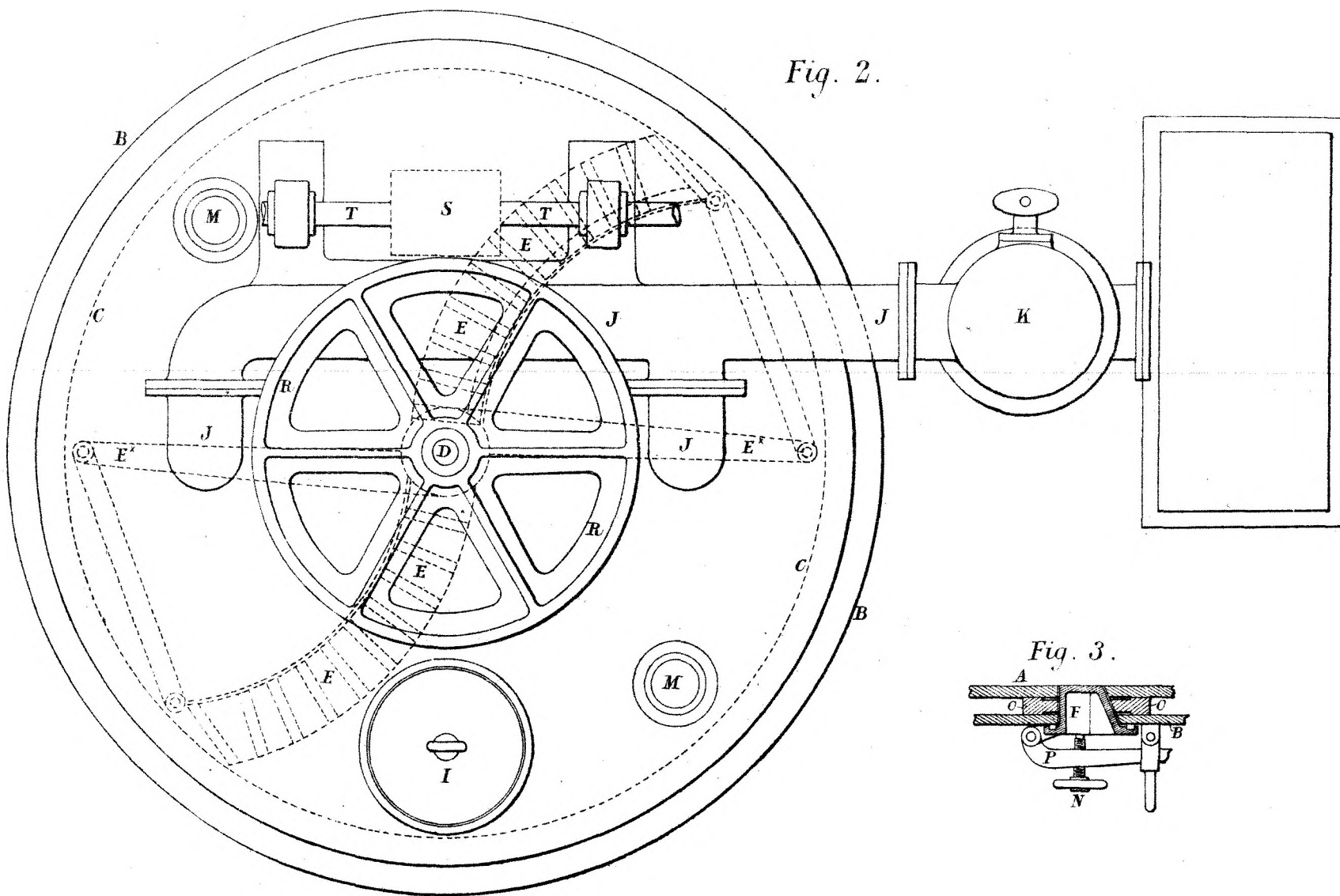
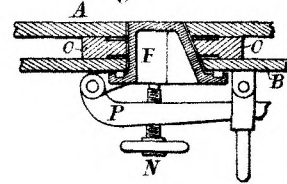


Fig. 3.



*This is the Sheet of Drawings referred to in the annexed
Letters of Registration, granted to John Forsyth Johnstone,
the fourteenth day of October, A.D. 1884.
Augustus Loftus.*



A.D. 1884, 17th October. No. 1519.

EAL'S MAIZE HUSKER AND SHELTER.

LETTERS OF REGISTRATION to John Eales, junior, for "Eales' Maize Husker and Sheller."

[Registered on the 18th day of October, 1884, in pursuance of the Act 16 Vic. No. 24.]

BY HIS EXCELLENCY THE RIGHT HONORABLE SIR AUGUSTUS WILLIAM FREDERICK SPENCER LOFTUS (commonly called LORD AUGUSTUS LOFTUS), Knight Grand Cross of the Most Honorable Order of the Bath, a Member of Her Majesty's Most Honorable Privy Council, Governor and Commander-in-Chief of the Colony of New South Wales and its Dependencies.

TO ALL TO WHOM THESE PRESENTS SHALL COME, greeting:

WHEREAS JOHN EAL'S, junior, of Duckenfield, Morpeth, in the Colony of New South Wales, engineer, hath by his Petition humbly represented to me that he is the author or designer of a certain invention or improvement in manufactures, that is to say, of an invention entitled "Eales' Maize Husker and Sheller," which is more particularly described in the specification marked A and the three sheets of drawings, marked B, C, and D respectively, which are hereunto annexed; and that he, the said Petitioner, hath deposited with the Honorable the Treasurer of the said Colony of New South Wales the sum of Twenty Pounds sterling, for defraying the expense of granting these Letters of Registration as required by the Act of Council, sixteenth Victoria number twenty-four; and hath humbly prayed that I would be pleased to grant Letters of Registration, whereby the exclusive enjoyment and advantage of the said invention or improvement might be secured to him for a period of fourteen years: And I, being willing to give encouragement to all inventions and improvements in the arts or manufactures which may be for the public good, and having received a report favourable to the prayer of the said Petition from competent persons appointed by me to examine and consider the matters stated therein and to report thereon for my information, am pleased, with the advice of the Executive Council, and in exercise of the power and authority given to me by the said Act of Council, to grant, and do by these Letters of Registration grant unto the said John Eales, his executors, administrators, and assigns, the exclusive enjoyment and advantage of the said invention or improvement for and during the term of fourteen years from the date hereof; to have, hold, and exercise unto the said John Eales, his executors, administrators, and assigns, the exclusive enjoyment and advantage thereof, for and during and unto the full end and term of fourteen years from the date of these presents next and immediately ensuing, and fully to be complete and ended: Provided always, that if the said John Eales shall not, within three days after the granting of these Letters of Registration, register the same in the proper office in the Supreme Court, at Sydney, in the said Colony of New South Wales, then these Letters of Registration, and all advantages whatsoever hereby granted, shall cease and become void.

In witness whereof, I have hereunto set my sign manual, and have caused the present Letters of Registration to be sealed with the seal of the said Colony of New South Wales, at Government House, Sydney, in New South Wales, this seventeenth day of October, in the year of our Lord one thousand eight hundred and eighty-four.

[L.S.]

AUGUSTUS LOFTUS.

Eales' Maize Husker and Sheller.

A.

TO ALL TO WHOM THESE PRESENTS SHALL COME, JOHN EALES, junior, of Duckenfield, Morpeth, in the Colony of New South Wales, engineer, send greeting :

WHEREAS I am desirous of obtaining Letters of Registration for securing unto me Her Majesty's Special License that I, my executors, administrators, and assigns, and such others that I or they shall at any time agree with, and no others, shall and lawfully may, from time to time, and at all times, during the term of fourteen years from the day on which this instrument shall be left at the office of the Minister of Justice, Sydney, make, use, exercise, and vend within the Colony of New South Wales an invention entitled "Eales' Maize Husker and Sheller," of improvements in maize huskers and shellers, as more particularly described in the following specification and accompanying drawings, viz. :—

SPECIFICATION.

THE object of my invention is the more perfect and rapid husking and shelling of maize or Indian corn almost simultaneously and without loss of the grain.

As is well known, the custom has hitherto been to husk maize by a machine which does its work very slowly and imperfectly, or by the hand. These methods are very objectionable, first, on account of the length of time required ; secondly, because of the loss of grain ; and thirdly, because of the number of times the cob is in hand. By my process the maize is husked and shelled almost at the same moment and swiftly.

My invention consists of a long cylinder (or drum) revolving within a concave (or apron), in the circumference of which are placed properly shaped teeth, that is to say, both in the inner circumference of the concave and the outer of the cylinder, to detach and strip the husk and grain from the cob. The cobs and husks, after having been dealt with by the cylinder and concave arrangement of teeth, are passed out at one end, the grain being passed over a number of riddles and exposed to a strong blast, by which it is effectually cleaned. Such is the process effected by my invention ; but I wish it to be clearly understood that it is for my cylinder and concave and the arrangement of teeth that I seek protection.

In order that my invention may be more clearly understood, drawings, which illustrate the same clearly, accompany this specification.

B is the cylinder or drum ; A is the concave or apron ; C shows the order of teeth in concave, and the reverse of the same shows that of the teeth in cylinder.

Sheet 1 shows the machine as fitted to clean, husk, and shell corn, and from which the working of the machine will be understood.

C' is the mouth through which the unhusked corn is fed as fast as the machine will take it.

Having thus described the nature of my invention and the manner in which it does its work, I wish it understood that I do not confine myself to the precise details herein set forth and explained, so long as the nature and principle of my invention be retained ; but that I do claim, especially—

First—Making the cylinder and teeth in a peculiar way as to shape.

Second—Making the teeth of a certain form.

Third—Making the cylinder and concave movable.

JOHN EALES, JUNIOR.

2, Wentworth Court, 30 August, 1884.

This is the specification marked "A" referred to in the annexed Letters of Registration granted to John Eales, junior, the seventeenth day of October, A.D. 1884.

AUGUSTUS LOFTUS.

REPORT.

Sir,

We do ourselves the honor to report, in reply to your blank cover of the 3rd instant, No. 9,324, transmitting Mr. John Eales, junior's, Petition for the registration of an invention for improvements in maize huskers and shellers, entitled "Eales' Maize Husker and Sheller," that we are of opinion the prayer of the Petitioner may be granted, in terms of his specification, drawings, and claims.

We have, &c.,

EDMUND FOSBERY.
GOTTLIEB K. MANN.

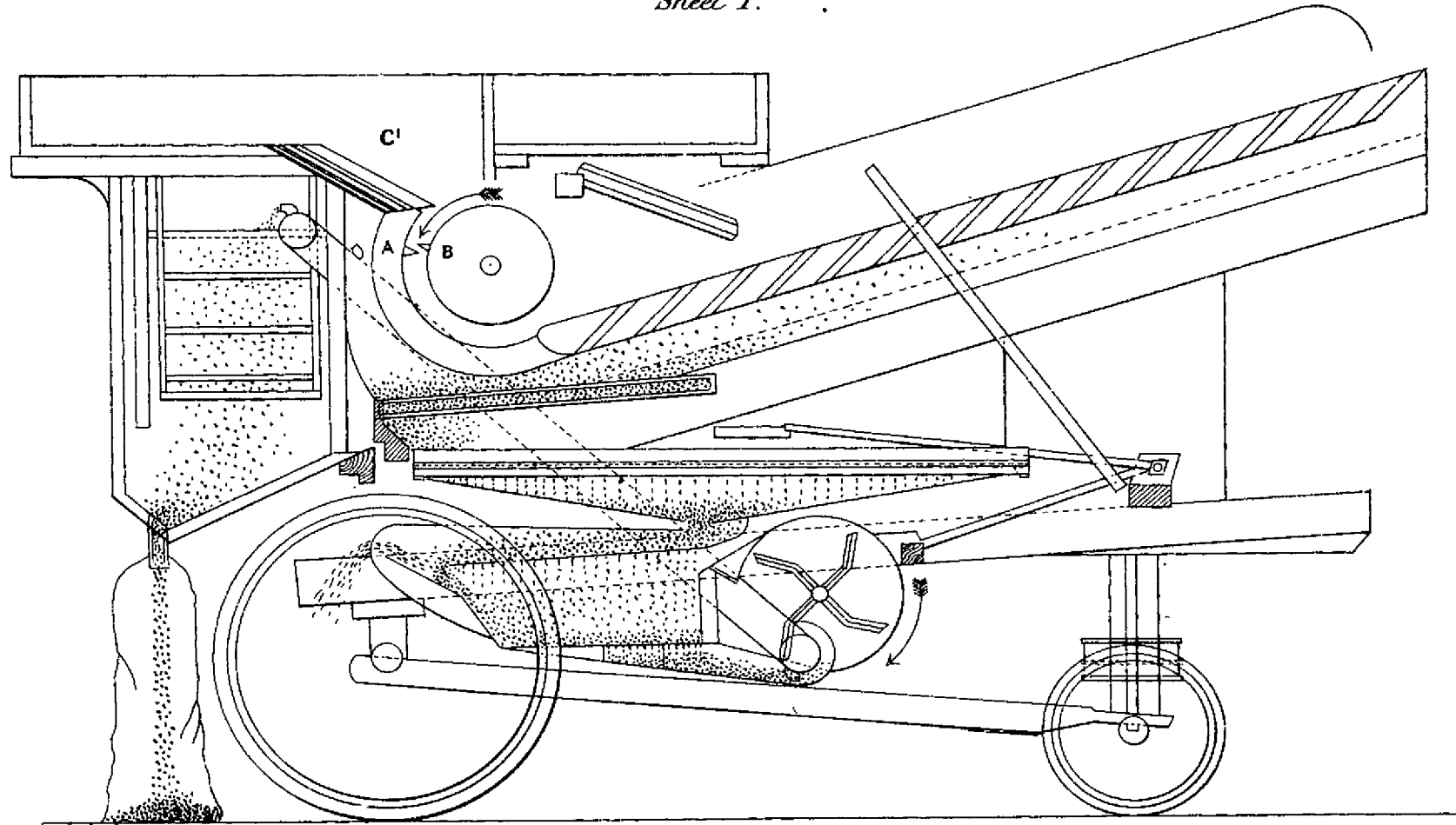
The Under Secretary of Justice.

[Drawings—three sheets.]

No. 1520.

[Assignment of No. 1175. See Letters of Registration for 1882, page 481.]

GENERAL PLAN OF INDIAN CORN SHELLER AND DRESSER.
Sheet 1.

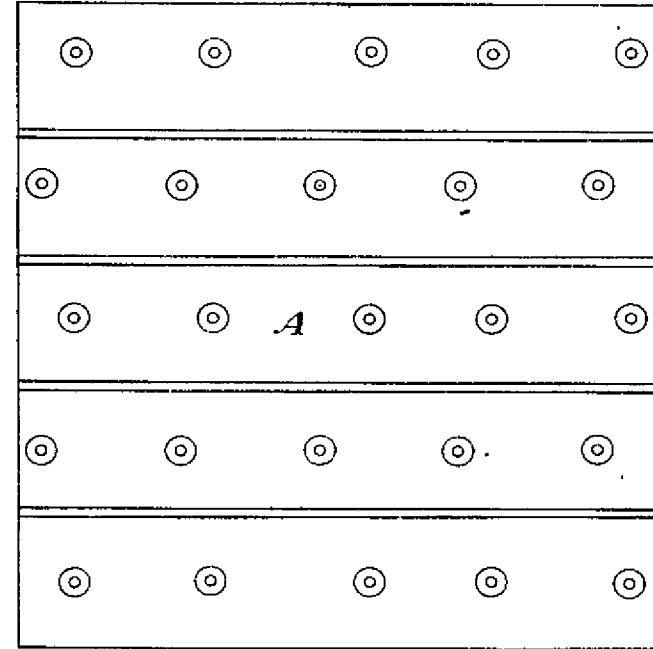
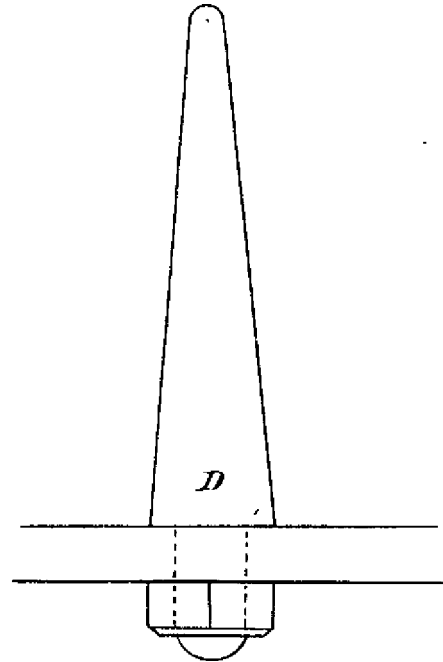
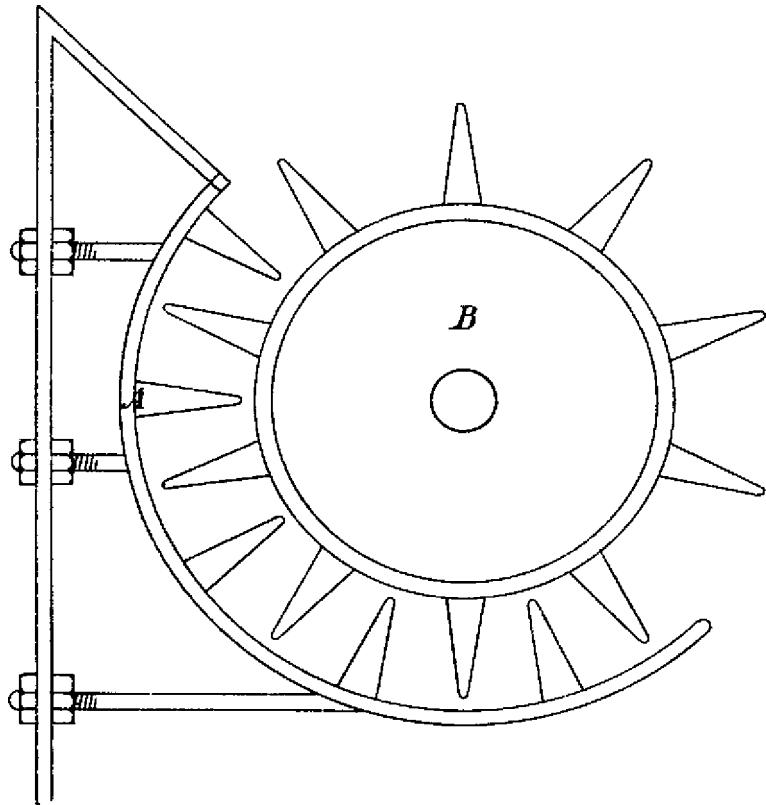


This is the Sheet of Drawings marked B referred to in the annexed Letters of Registration granted to John Eales, Junr, the seventeenth day of October, A., D. 1884.

Augustus Loftus.

DETAIL OF DRUM AND APRON.

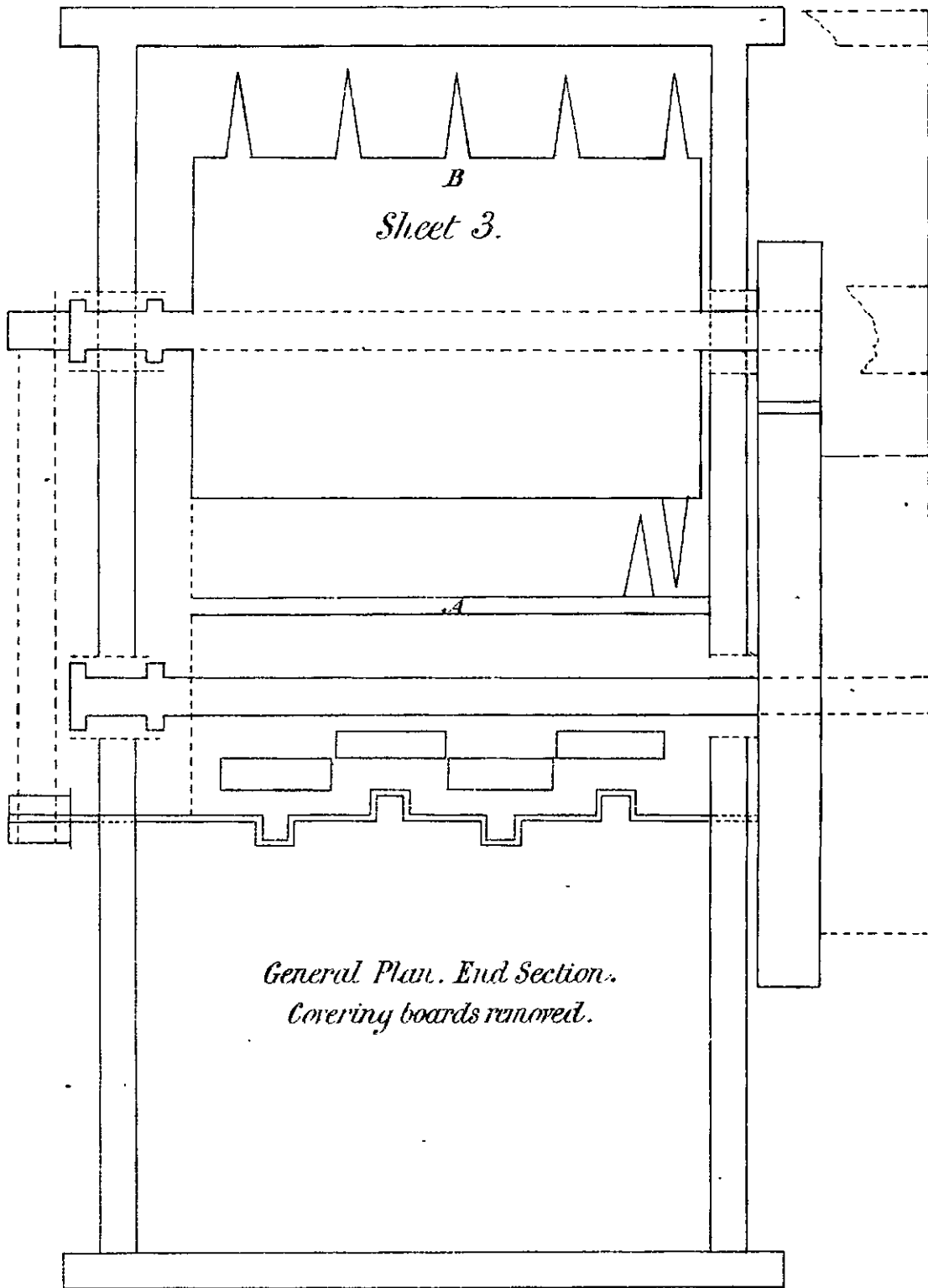
Sheet 2.



This is the Sheet of Drawings marked 'C' referred to in the annexed Letters of Registration, granted to John Eales Junr the seventeenth day of October AD 1884.

Augustus Loftus.

VERTICAL SECTION OF DRUM AND APRON.



*General Plan. End Section.
Covering boards removed.*

This is the Sheet of Drawings marked D, referred to in the annexed Letters of Registration, granted to John Eales, Junr the seventeenth day of October, A.D., 1884.

Augustus Loftus.

(Sig: 245)



A.D. 1884, 22nd October. No. 1521.

IMPROVEMENTS IN BORING MACHINES.

LETTERS OF REGISTRATION to Arthur Henderson Robinson, for Improvements in Apparatus or Machines for boring the ground for water or other purposes.

[Registered on the 22nd day of October, 1884, in pursuance of the Act 16 Vic. No. 24.]

BY HIS EXCELLENCY THE RIGHT HONORABLE SIR AUGUSTUS WILLIAM FREDERICK SPENCER LOFTUS, (commonly called LORD AUGUSTUS LOFTUS), Knight Grand Cross of the Most Honorable Order of the Bath, a Member of Her Majesty's Most Honorable Privy Council, Governor and Commander-in-Chief of the Colony of New South Wales and its Dependencies.

TO ALL TO WHOM THESE PRESENTS SHALL COME, greeting :

WHEREAS ARTHUR HENDERSON ROBINSON, of 30, Wynyard-square, Sydney, civil engineer, hath by his Petition humbly represented to me that he is the author or designer of a certain invention or improvement in manufactures, that is to say, of an invention entitled "Improvements in Apparatus or Machines for Boring the ground for water or other purposes," which is more particularly described in the specification marked "A" and the two sheets of drawings marked "B" and "C" respectively which are hereunto annexed; and that he, the said Petitioner, hath deposited with the Honorable the Treasurer of the said Colony of New South Wales the sum of Twenty Pounds sterling, for defraying the expense of granting these Letters of Registration, as required by the Act of Council, sixteenth Victoria, number twenty-four; and hath humbly prayed that I would be pleased to grant Letters of Registration, whereby the exclusive enjoyment and advantage of the said invention or improvement might be secured to him for a period of fourteen years: And I, being willing to give encouragement to all inventions and improvements in the arts or manufactures which may be for the public good, and having received a report favourable to the prayer of the said Petition from competent persons appointed by me to examine and consider the matters stated therein and to report thereon for my information, am pleased, with the advice of the Executive Council, and in exercise of the power and authority given to me by the said Act of Council, to grant, and do by these Letters of Registration grant unto the said Arthur Henderson Robinson, his executors, administrators, and assigns, the exclusive enjoyment and advantage of the said invention or improvement for and during the term of fourteen years from the date hereof; to have, hold, and exercise unto the said Arthur Henderson Robinson, his executors, administrators, and assigns, the exclusive enjoyment and advantage thereof, for and during and unto the full end and term of fourteen years from the date of these presents next and immediately ensuing, and fully to be complete and ended: Provided always, that if the said Arthur Henderson Robinson shall not, within three days after the granting of these Letters of Registration, register the same in the proper office of the Supreme Court, at Sydney, in the said Colony of New South Wales, then these Letters of Registration, and all advantages whatsoever hereby granted, shall cease and become void.

In witness whereof, I have hereunto set my sign manual, and have caused the present Letters of Registration to be sealed with the seal of the said Colony of New South Wales, at Government House, Sydney, in New South Wales, this twenty-second day of October, in the year of our Lord one thousand eight hundred and eighty-four.

[L.s.]

AUGUSTUS LOFTUS.

Improvements in Boring Machines.

"A."

TO ALL TO WHOM THESE PRESENTS SHALL COME, I, ARTHUR HENDERSON ROBINSON, of 36, Wynyard Square, in the city of Sydney, in the Colony of New South Wales, engineer, send greeting:

WHEREAS I am desirous of obtaining Letters of Registration for securing unto me Her Majesty's Special License that I, my executors, administrators, and assigns, and such others as I or they shall at any time agree with, and no others, shall and lawfully may, from time to time, and at all times, during the term of fourteen years, to be computed from the day on which this instrument shall be left at the office of the Minister of Justice, Sydney, make, use, exercise, and vend, within the Colony of New South Wales, "An Invention for Improvements in Apparatus or Machines for boring the ground for water or other purposes," to be called "The Conqueror," as more particularly described in the following specification:—

SPECIFICATION.

My invention has for its object the production of an effective and inexpensive apparatus or machine, capable of boring, in an expeditious manner, the earth or ground through any class of strata, whether through alluvial soil, sand-stone, conglomerate rock, or other strata whatsoever that may be met with, thereby combining in one apparatus or machine most valuable advantages not possessed to the same extent by any one machine heretofore introduced.

Figure 1, sheet 1, is a side elevation, partly in section, of my said apparatus or machine, showing the lower portion of the derrick. Pawl Z is not shown in this drawing.

Figure 2, also sheet 1, is a plan of the said apparatus or machine with the derrick removed.

Figure 3, sheet 2, is a side elevation of the said apparatus or machine with the derrick in position.

Figure 4, also sheet 2, is a plan of the derrick and the side frames and sole-plate of said apparatus or machine.

My said invention is constructed as follows, namely:—On a bed-plate A, which is provided at one end with a circular-flanged opening B, provided with a female screw, I mount, as shown in figure 1, sheet 1, a jacket of cylindrical form, which is provided internally with a screw or worm (as shown in part section at figure 1) for its entire length, save at the top or mouth of same, into which is fitted a guide-ring D. Within this jacket I place a ram or piston E, also shown in part section in figure 1, sheet 1. This ram or piston is of equal diameter to the opening at the mouth of the said jacket. It consists of a plain hollow cylinder, having at its lower end a base F of the diameter equal to that of the interior of the said jacket. This base is provided with a thread or worm corresponding to the thread or worm in the jacket previously referred to. The said ram or piston is also provided with a longitudinal slot G (hereinafter referred to) from the top to the surface of the base. The top of this ram or piston is provided with a neck H, also shown in part section in figure 1, sheet 1. On said neck I mount a loose ring K of equal diameter to the said ram or piston. This ring is likewise slotted, and forms a portion of the said ram or piston, and both may be rotated together as one piece, or the ring may be rotated separately as hereinafter explained. This ring is also provided with a key-way internally, explained further on. I also mount on the said ram or piston another ring or top-piece L, also shown in part section at figure 1, sheet 1, which rotates freely within the first-mentioned ring. This top-piece is provided with two key-ways m m^2 —one for coupling it to the first-mentioned ring, the second for coupling it to the ram or piston. The said top-piece is also provided with side-holes M M for the purpose of inserting therein levers or hand-spikes, for the purpose of working the said ram or piston up or down, independently of the other motion hereinafter referred to. Upon the top of the jacket I mount a worm-wheel N. This worm-wheel has for its centre bearing the ring K above referred to, and it is provided with a slot or key-way G internally, and corresponding to that in the ring K and ram or piston. This worm-wheel rotates as hereinafter explained, carrying with it the loose ring K or the ram or piston before-mentioned.

The top-piece L is screwed internally, and to it or the ring K I attach any well-gripping device, which may be of two or more forms, as, for instance, the one for rotating and pressing forward the rods or tubes when coupled with the feed-motion, such as a self-centering or adjusting lathe-chuck, which would take a rigid hold of anything clamped within it, and descend with the ram or piston. Another form would be used when the operation of rotating the drill-rods, tube, chain, or rope, without the feed-motion of the ram or piston, as, for instance, a similar device to the former, or any other well-known gripping device, which would impart to the rods, &c., a rotary motion, but at same time admit of their sliding downwards through it, of their own weight. This latter device would be attached to the loose ring K, and would merely rotate without descending. The said top-piece is removed when it is considered desirable to work either of the gripping devices direct off the ring K, in which case the opening through the ram or piston E is of a uniform size, and such diameter as will admit the passage through it of any earth-auger, drill, boring-tool, tubing, or other necessary device or tool that may be required.

In conjunction with the grippers hereinbefore mentioned (which will be centering pieces as well as grippers), a loose ring or disc-plate may be employed internally at the bottom of the ram or piston, as a further central guide for the rods or tubing hereinafter referred to. This ring or disc-plate would be free to rotate within the said ram or piston when the latter would be stationary, and would be so constructed as to open and be adjustable to suit any required size of rod or tubing. Said ring may be kept in position by three stud-pins projecting internally at the base of the ram or piston. While approving of the second guide, it is not absolutely necessary that such should be provided.

I further attach to the said bed-plate a winch or windlass, as shown at figures 1 and 2, sheet 1. This winch is constructed as follows:—The side cheeks or frames V¹ and V² form the bearings for the requisite shafting. These cheeks or frames are bound together by the sole-plate at the bottom, and at the top by the bolt 10. Shaft No. 1 carries a worm R (which is made fast to it by a pin or other suitable means), a small staked toothed wheel or pinion S, also a keyed treble cam or tipping device T, both hereinafter referred to. Shaft No. 2 carries a double-winding or hauling drum (one being fast and the other loose on the shaft), also a loose-toothed wheel V, and a fast-toothed wheel W, both of the same diameter and pitch. The wheel V and the pinion S are always in gear. Shaft No. 3 carries a small staked toothed wheel or pinion X. This shaft has a sliding motion, and the wheel or pinion on it may be placed at the will of the operator in either of three positions—Firstly, in gear with the loose wheel V on shaft

No.

Improvements in Boring Machines.

No. 2, for the purpose of actuating it, and thereby working the pinion or small wheel S on shaft No. 1, also the worm on same shaft, which in turn communicates motion to the worm-wheel N; secondly, the pinion X may be placed between the loose wheel V and the fast wheel W, in which position the winch would be out of gear with the driving power or motor hereinafter referred to; or thirdly, the pinion X may be geared with the fast-wheel W, and thereby be made to actuate the drum or drums. Shaft No. 1 also carries a check-pawl Y, for the purpose of retaining the pinion X in the desired position. It also carries a pawl Z for preventing back-action of the wheel W, or the drum-shaft, save at the will of the operator.

On shaft No. 2, I also mount a friction drum, marked No. 5, against which the friction lever 6, carried on shaft No. 3, impinges, at the will of the operator, whenever he desires to reverse the winding drum or drums at a slow or moderate speed.

Between the side frames of the winch, and also between shafts Nos. 1 and 3, I erect a derrick or crane 7, as shown in figures Nos. 1 and 3, the foot of which is carried in a recess formed in the sole-plate 8 of the winch. The standard or vertical pillar of the said derrick at the bottom is made the exact width of the space between the frames V¹ V² of the winch, and receives lateral support from them. It is also made fast by the straps 9, as shown in the drawings at figure 3, sheet 2, to the bolt 10. At the top of the said derrick I mount four sheaves, two at each side, as also shown at figures 3 and 4, sheet 2, over which I pass a rope or other suitable chain or cable, the ends of which are made fast to the drums U U, the loop end 11 being provided with a block or sheave 12, as shown at figure 3, sheet 2. I also mount on said derrick a further sheave or pulley 13 in such a position as that a rope or chain let fall from it shall command the centre of the ram or piston. Over this sheave or pulley I pass a rope or chain, making fast one end to the cleat on lever 14, shown at figure 2, sheet 1, the other end being free to be attached at any time to a jar-bar, drilling, or boring-rod, hereinafter referred to. This sheave and rope or chain is only required when the lever 14 is brought into action; said lever and rope and chain may be dormant, or the sheave and rope or chain may be dismantled until so required. Lever 14 is carried in a pillar 15 attached to the bed-plate, and is operated by the cams or tappets T carried on shaft No. 1, shown on the drawings at figures Nos. 1 and 2, sheet 1. A pawl No. 16, shown in figure 3, is carried on bolt 10. This pawl serves to hold the shaft No. 3 in the second position hereinbefore referred to, and pawl Y on shaft No. 1 to secure the pinion X in gear with either of the wheels V or W.

The ram or piston hereinbefore referred to is provided with a thread or worm, and the cylinder-jacket with a corresponding thread or worm; but it is obvious that I may adopt a thread or worm of any pitch considered most desirable. The said ram or piston is caused to ascend or descend by the rotation of the worm-wheel to which it is coupled when desired, by means of the key G and slot G, the latter sliding upon the key. There are two keys provided for this slot, a long and a short one. The long key prevents the possibility of the ram or piston being over-worked in either direction. It acts as follows: By it the ram and piston is coupled to the ring and worm-wheel, and it remains in position during the natural travel of the ram or piston; but before the said ram arrives at its full travel upwards, the tail or end of the said key is brought into contact with the top of the base of the ram, and as it advances it sends the key before it, and by the time the ram has reached its full travel the upper portion of the key which fills the slots in the worm-wheel has cleared the said worm-wheel, the tail end only remaining in the slot with which it is flush. No further action of the ram then takes place. On descent of the ram or piston, after travelling its full length, on further advance it withdraws itself from the key, which, by the head, is not permitted to pass further than the top of the worm-wheel. Thus, the ram or piston is brought to a state of rest at these particular points, and the possibility of breakage from over-working prevented.

The said ram or piston and cylinder-jacket may be constructed of any desired size, and the upper portion of the said cylinder may stand at any convenient height above the bed-plate. The travel of the feed-ram or piston is in proportion to the length of the jacket, and I propose to construct some of the earth-augers and twist-drills of a length approximate to that of the travel of the ram or piston. By so doing, I shall be enabled to advance the boring by considerable lengths at each operation, and thus avoid loss of time by more frequent drawing of the rods, &c. Another important feature in this method is, that the raising of the ram or piston for further operation performs also at the same time the lifting of the core or contents of the auger without the aid of core extractors, &c., on the complete ascent on the ram or piston. The further raising of the auger is performed by the winch in the more rapid manner hereinbefore referred to, or the auger may be so lifted from the start. In some cases it will be necessary to start the withdrawal of the auger by aid of the ram or piston, as, for instance, in boring through a strata of stiff clay. I propose in some cases to use a twist-auger proportionate to the length of the travel of the ram. This auger would be fed forward into the ground for its entire length, at the termination of which the gripping device hereinbefore described, which caused it to rotate with the ram, would be substituted for any well-known clamp or lifting device, which would be free to turn on the upper surface of the ram without rotating the twist auger, but merely drawing it and its core out of that portion of the ground penetrated, after which operation the further lifting may be performed in the more rapid manner.

By the aid of the said ram or piston, I propose inserting any tubing necessary for lining purposes, also to withdraw the same at pleasure, thereby dispensing with screw-jacks or other necessary gear for such purposes, the ram itself being equivalent to a screw-jack.

In the side of the said cylinder jacket I form openings for the purpose of screwing it into position. The guide ring D at the mouth of the jacket should be removed for the purpose of inserting the ram or piston, and be subsequently replaced. The worm-wheel N shown in drawings is provided with forty teeth, and makes one revolution for every forty of the worm by which it is rotated; but I do not confine myself to this particular number or pitch. I propose providing a set of worm-wheels, hereinafter called "change-wheels." These change-wheels may be of any desired speed or pitch, and I may mount any one of them on the top of the jacket by simply placing it over the ring K, in which position it will be in gear with the worm R, carried on shaft No. 1. This worm I also propose providing in sets to suit the worm-wheels. They may rapidly and readily be inserted on the said shaft, which is capable of being withdrawn for the purpose. By this arrangement I shall be enabled to feed forward the augers or drills at any speed that may be required to suit the class of ground being bored through or bit in use; or, in lieu of this method

Improvements in Boring Machines.

method of varying the speed, I may employ change-wheels on the winch instead. The drums U U, I couple together by a pin passed through the centre flanges. This enables the winding or hauling to be done in a more rapid manner, consequently, a great saving of time is effected in the raising or lowering of the rods, &c. The said drums may be disconnected at the will of the operator by the removal of the said pin, and the old method resorted to, if at any time desirable.

With the apparatus or machine hereinbefore described and illustrated, I employ, for the purpose of carrying out the boring or drilling, any well-known class of boring-rods, couplings, earth-augers, steel drills, and other well-known tools of a suitable nature; or I may employ with my said apparatus or machine a bit set with diamonds in the ordinary manner, the rotary and feed motion of said bit being furnished and regulated by the change-wheels hereinbefore referred to. The diamond bit I propose carrying in the ordinary well-known manner, and provided with the necessary and well-known tubing, &c., for the water supply, &c. I also may employ for the purpose of extracting the core, any well-known class of core-extractors or other well-known suitable tools. For the purpose of clearing the bore-hole of any debris or loose matter created by the jar-bar and drill, I employ the ordinary class of pump used for this purpose, or I may employ any other suitable and well-known class of pump for the purpose, as, for instance, I may lower a short force-pump to the bottom of the bore-hole attached to a length of tubing reaching to surface. Through this tubing I may operate a rod connected to the piston or plunger of said pump, and thus draw away the debris, water, or other matter through the said tubing. The manner of working the rod of the said pump would be similar to that for working the jar-bar hereinbefore described.

Shaft No. 3 may be provided with an eccentric, and operated by any well-known motor carried on the bed-plate or adjacent thereto, or it may be provided with a band wheel, and operated by any suitable horse-gear.

It is at times desirable to sight the interior of the bore, and for this purpose I employ, as shown in use at figure 3, the following electric apparatus lettered *o, il est*, an electric battery of well-known construction, and provided with suitable and well-known connections for illuminating an electric lamp or lamps of the incandescent class. The mode of carrying out this operation is as follows:—I lower the said lamp or lamps to the bottom of the bore-hole, or at suitable distances along the said cable, by means of a suitable cable for conducting the electric fluid to and from the said lamp or lamps. I also connect the wires in the usual way with the battery. This being done, the lamp or lamps become luminous, and thereby enables the operator to sight the interior of the bore, and thus discover the position and cause of any obstruction or deflection therein.

The manner of operating the said apparatus or machine is as follows:—A, the site selected for boring, I make an opening in the ground of (say) 3 or 4 feet in depth, and of a diameter sufficient to admit the lower portion of the cylinder-jacket. Over the opening I erect the said apparatus, as shown in the drawings hereto annexed. I then take a boring-rod of suitable length. I attach to it, in the ordinary manner, an earth-auger or other boring-tool. I couple the head of this boring-rod to the block or sheave suspended from the derrick. I elevate the said boring-rod by means of the winch and lower it into the ram or piston to the bottom of the opening above referred to. I then take the gripping device, also hereinbefore referred, pass it over the rod, and attach it to the head or top-piece of the said ram or piston, and, having rigidly clamped the boring-rod within it and inserted the keys hereinbefore described, the apparatus may be set in motion and the boring commenced, the ram or piston having been previously raised to the proper height to supply the necessary feed motion, which may be continued for the full travel of the ram or piston, or at the will of the operator stopped, and the boring carried out by the pressure of the rods on the auger, the rotary motion only imparted to the auger or drill. This change may be effected in a rapid and simple manner, by merely substituting the short key for the long one hereinbefore described, and by removing the gripping device and substituting for it the other form, which admits of the rod or rods descending through it of their own weight. Should rock or boulder stone be met with at any stage of the operation, I withdraw the auger or other tool by means of the winch, the lifting being performed in a rapid manner by the coiling on the double drum of both ends of the rope or chain at once. Having removed the rods, &c., then in use, I attach to the free end of the rope or chain, passing over the sheave or pulley 13 previously explained a jar-bar carrying a suitable drill, and having lowered said drill on the face of the rock or stone I set the apparatus again in motion, this time employing the lever 14, and thereby operating the said jar-bar or drill. This operation is continued until the rock or stone is pierced; or, in lieu of this method, a steel cutter connected with the drill-rod or rods may be operated in the same manner as the earth-auger previously described. A suitable gripping device, rotated by aid of the worm-wheel, which is also in action, gives a rotary motion to the jar-bar or drill. The rope or chain carrying the said jar-bar or drill may be of any required length, and be paid out as the drilling is proceeded with. Should soft ground be again met with, the boring as first described is resumed.

The facility and rapidity of adjusting my said apparatus or machine for any of the hereinbefore-mentioned operations is an important advantage attained by the novel combinations and arrangements of the parts also herein illustrated and described.

Having thus described and illustrated my said invention, and the method of carrying the same into effect, I would have it understood that I distinctly disclaim everything hereinbefore described except the improvements hereinafter set forth and specially claimed, thus—

I claim as the invention for which I am desirous of securing Letters of Registration—

Firstly.—The general construction, arrangement, and combination of the parts of the hereinbefore illustrated and described improved apparatus or machine, substantially as set forth.

Secondly.—In a boring apparatus or machine, the combination of a piston or ram working in a jacket or cylinder and operated by a worm-wheel, keyed as described, with a winch, constructed and arranged as illustrated and described, substantially as set forth.

Thirdly.—In a boring apparatus or machine, the combination of a piston or ram working in a jacket or cylinder and provided with loose rings, keyed as described, with a lever actuated by cams or a slipping device, constructed and arranged as illustrated and described, substantially as set forth.

Fourthly.—

Improvements in Boring Machines.

- Fourthly.—In a boring apparatus or machine, the combination of a piston or ram working in a jacket or cylinder with a double winding drum and derrick, constructed and arranged as illustrated and described, substantially as set forth.
- Fifthly.—In a boring apparatus or machine, provided with a set of change-wheels, the combination of a piston or ram working in a jacket or cylinder, with a winch or winding apparatus, constructed and arranged as illustrated and described, substantially as set forth.
- Sixthly.—In a boring apparatus or machine, the combination of a piston or ram working in a jacket or cylinder, operated by a worm-wheel and worm, with an electric apparatus or device as and for the purpose stated, and as illustrated and described, substantially as set forth.
- Seventhly.—In a boring apparatus, the combination of a double drum, as and for the purposes mentioned, with a piston and ram working in a jacket or cylinder carried in a bed-plate, and operated as illustrated and described, substantially as set forth.
- Eighthly.—In a boring apparatus, the combination of a derrick provided with four sheaves or pulleys, and a block for raising and lowering purposes, with a double-winding drum carried in a winch and described, substantially as set forth.
- Ninthly.—In a boring apparatus or machine, the combination of a lever operated by a tipping device or cams with a rope or chain carried in a sheave or pulley on the face of a derrick, said sheave being mounted over a ram or piston, carried in a jacket or cylinder, and operating in the manner described and illustrated, substantially as set forth.

ARTHUR HENDERSON ROBINSON.

2, Wentworth Court, Sydney, 21st July, 1884.

This is the specification marked "A," referred to in the annexed Letters of Registration granted to Arthur Henderson Robinson, the 22nd day of October, A.D. 1884.

AUGUSTUS LOFTUS.

REPORT.

Sir,

Sydney, 4 August, 1884.

We do ourselves the honor to report, in reply to your blank cover of the 22nd ultimo, transmitting Mr. Arthur Henderson Robinson's Petition for the registration of an invention entitled "Improvements in Apparatus or Machines for boring the ground for water or other purposes," that we are of opinion the prayer of the Petitioner may be granted, in terms of his specification, drawings, and claim.

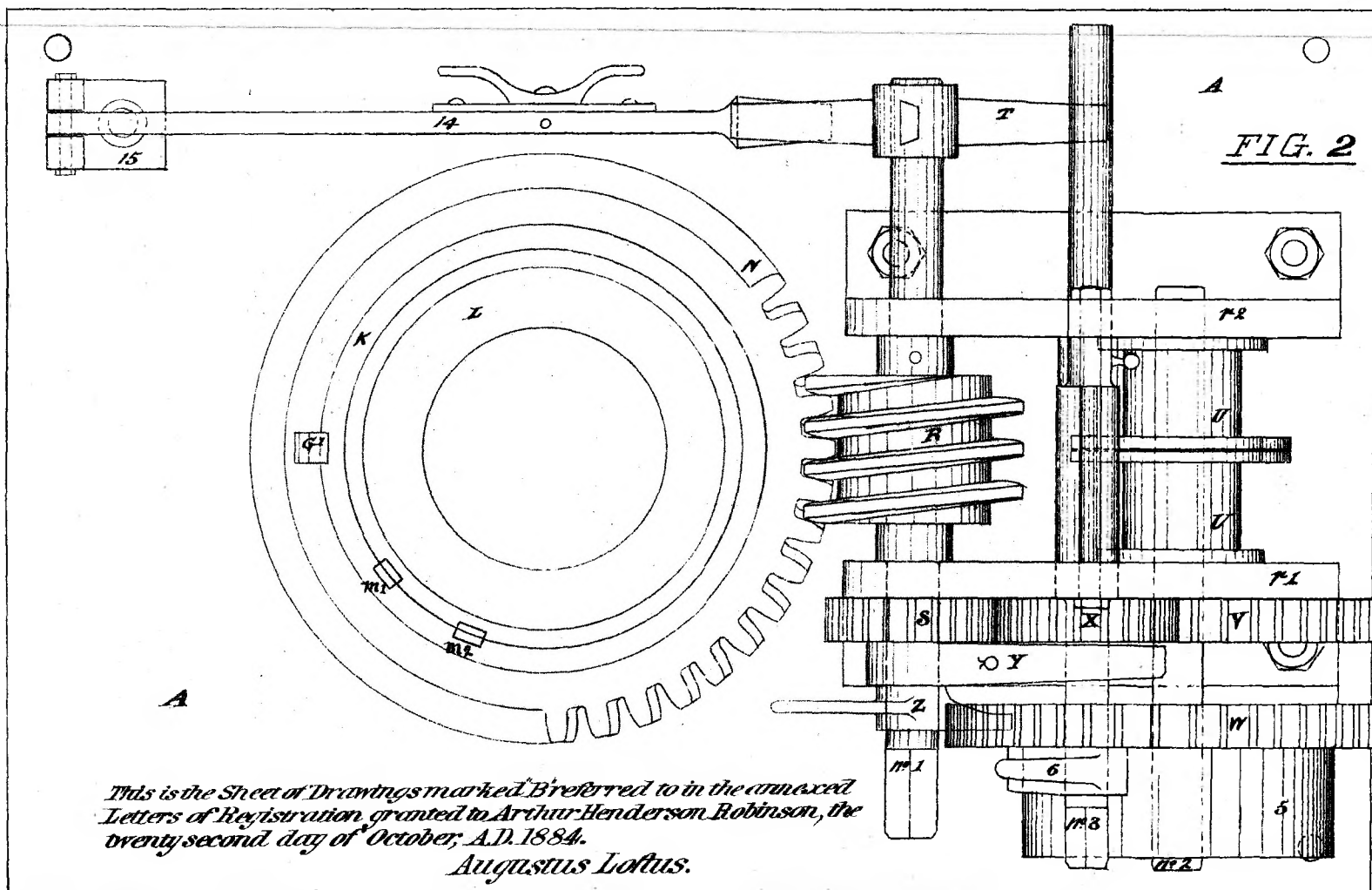
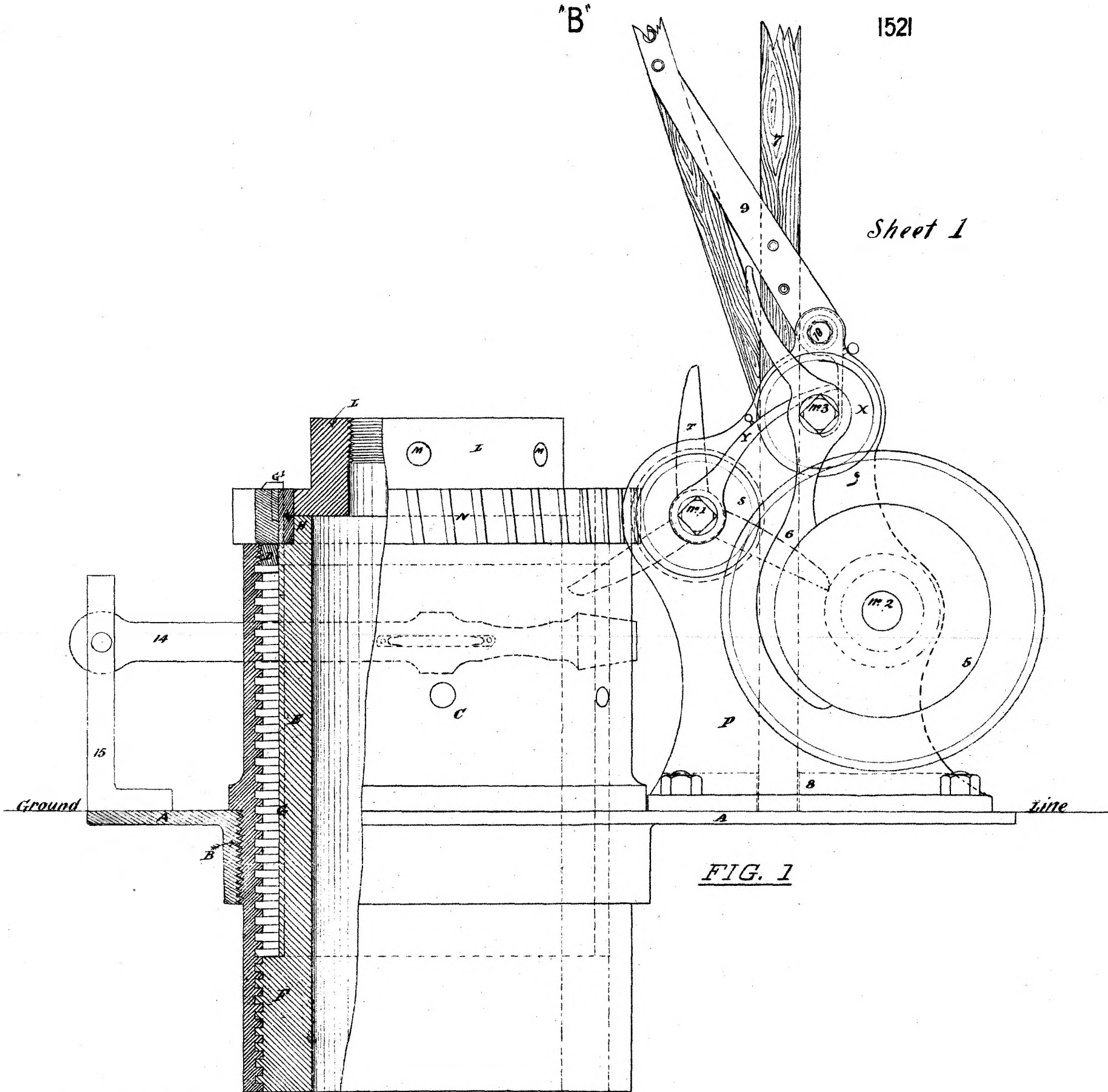
We have, &c.,

GOTHER K. MANN.
E. O. MORIARTY.

The Under Secretary of Justice.

[Drawings—two sheets.]

245—7 L



This is the Sheet of Drawings marked B referred to in the annexed Letters of Registration, granted to Arthur Henderson Robinson, the twenty-second day of October, A.D. 1884.
Augustus Loftus.

(Sig 245-)

Arthur Henderson Robinson
21 July 1884

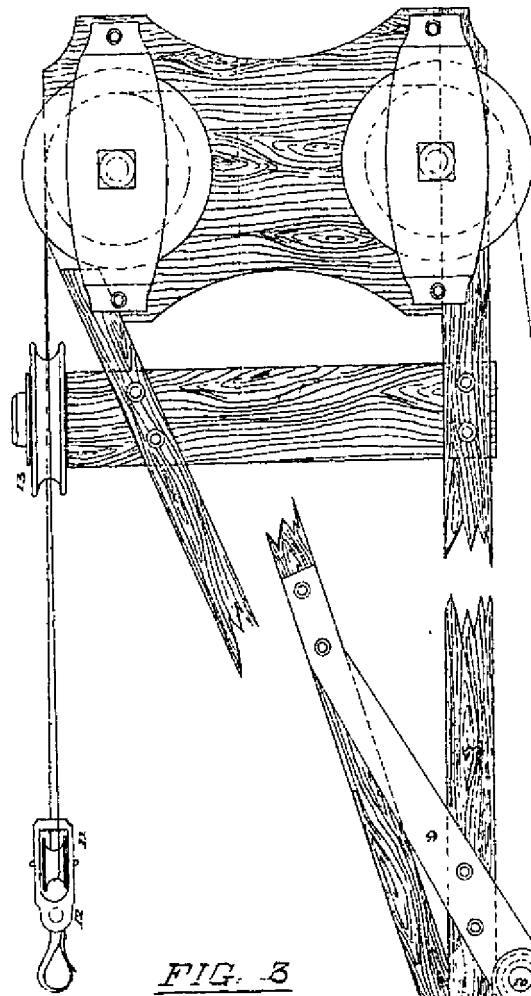


FIG. 3

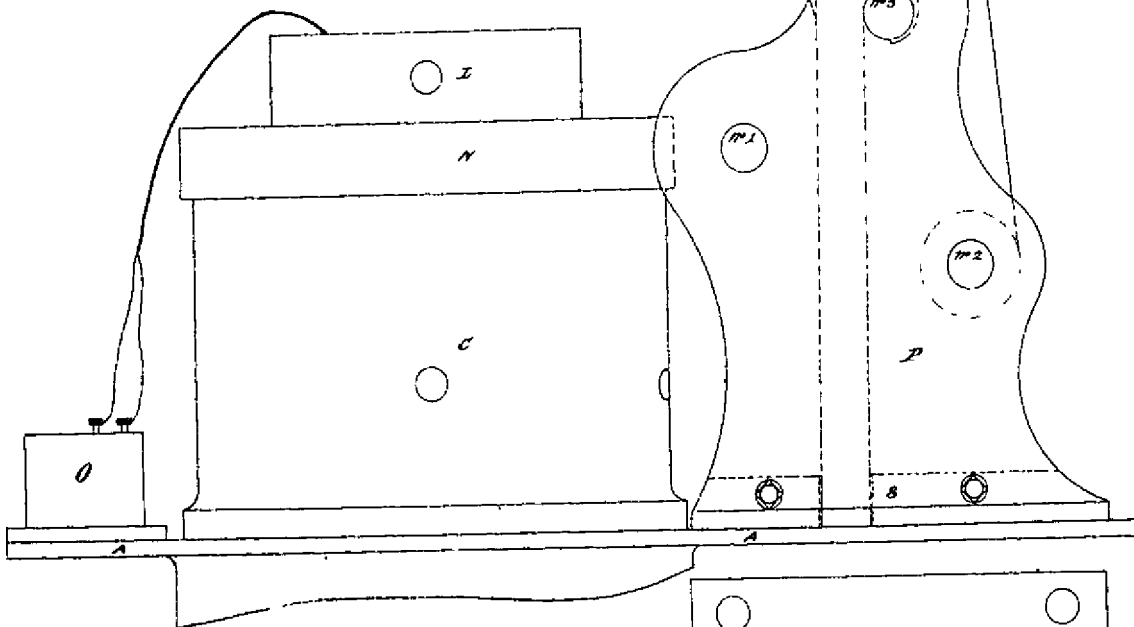
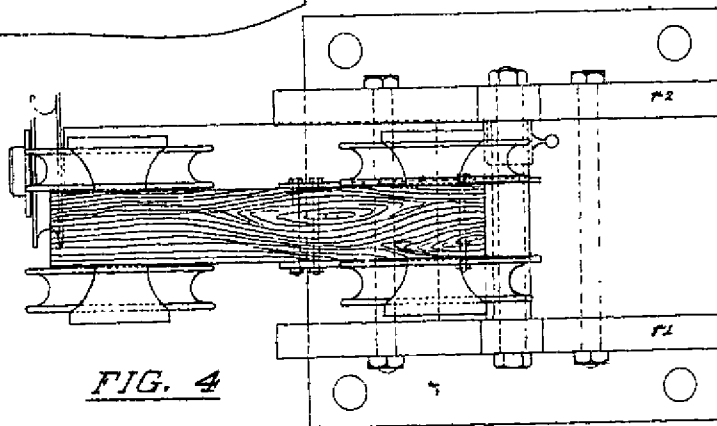


FIG. 4



(Sig 245-)

This is the Sheet of Drawings marked C referred to in the annexed Letters of Registration, granted to Arthur Henderson Robinson, the twenty-second day of October, A.D. 1884.

Augustus Loftus.

Arthur Henderson Robinson
25 July 1884



A.D. 1884, 22nd October. No. 1522.

AN IMPROVED WIRE STRAINER.

LETTERS OF REGISTRATION to Charles Osbern Ralph Walker, for an improved Wire Strainer.

[Registered on the 22nd day of October, 1884, in pursuance of the Act 16 Vic. No. 24.]

BY HIS EXCELLENCY THE RIGHT HONORABLE SIR AUGUSTUS WILLIAM FREDERICK SPENCER LOFTUS (commonly called LORD AUGUSTUS LOFTUS), Knight Grand Cross of the Most Honorable Order of the Bath, a Member of Her Majesty's Most Honorable Privy Council, Governor and Commander-in-Chief of the Colony of New South Wales and its Dependencies.

TO ALL TO WHOM THESE PRESENTS SHALL COME, greeting :

WHEREAS CHARLES OSBERN RALPH WALKER, of Coolart, Balnaring, in the Colony of Victoria, station manager, hath by his Petition humbly represented to me that he is the author or designer of a certain invention or improvement in manufactures, that is to say, of an invention entitled "An improved Wire Strainer," which is more particularly described in the specification, marked A, the addition to the specification, marked B, and the two sheets of drawings, marked C and D respectively, which are hereunto annexed; and that he, the said Petitioner, hath deposited with the Honorable the Treasurer of the said Colony of New South Wales the sum of Twenty Pounds sterling, for defraying the expense of granting these Letters of Registration, as required by the Act of Council, sixteenth Victoria, number twenty-four; and hath humbly prayed that I would be pleased to grant Letters of Registration, whereby the exclusive enjoyment and advantage of the said invention or improvement might be secured to him for a period of fourteen years: And I, being willing to give encouragement to all inventions and improvements in the arts or manufactures which may be for the public good, and having received a report favourable to the prayer of the said Petition, from competent persons appointed by me to examine and consider the matters stated therein and to report thereon for my information, am pleased, with the advice of the Executive Council, and in exercise of the power and authority given to me by the said Act of Council, to grant, and do by these Letters of Registration grant unto the said Charles Osbern Ralph Walker, his executors, administrators, and assigns, the exclusive enjoyment and advantage of the said invention or improvement, for and during the term of fourteen years from the date hereof; to have, hold, and exercise unto the said Charles Osbern Ralph Walker, his executors, administrators, and assigns, the exclusive enjoyment and advantage thereof, for and during and unto the full end and term of fourteen years from the date of these presents next and immediately ensuing, and fully to be complete and ended: Provided always, that if the said Charles Osbern Ralph Walker shall not, within three days after the granting of these Letters of Registration, register the same in the proper office in the Supreme Court, at Sydney, in the said Colony of New South Wales, then these Letters of Registration, and all advantages whatsoever hereby granted, shall cease and become void.

In witness whereof, I have hereunto set my sign manual, and have caused the present Letters of Registration to be sealed with the seal of the said Colony of New South Wales, at Government House, Sydney, in New South Wales, this twenty-second day of October, in the year of our Lord one thousand eight hundred and eighty-four.

[L.S.]

AUGUSTUS LOFTUS.

An improved Wire Strainer.

A.

SPECIFICATION of CHARLES OSBERN RALPH WALKER, of Coolart, Balnaring, in the Colony of Victoria, station manager, for an invention entitled "An improved Wire Strainer."

THIS invention has been devised for the purpose of producing a wire strainer so cheap that it may remain permanently affixed to the wire fencing, and so simple that it may be instantly used for tightening or slackening the wire at pleasure. It consists of a short roller, recessed in the centre for about one-third of its length, so that its ends are of a larger diameter than its centre. This central recess is the part on which the wire is wound or unwound, and has a hole made quite through it, for the purpose of receiving and fastening the end of the wire. Each of the two ends has two holes made quite through it, preferably at right angles to each other. These are for the purpose of receiving the ends of the levers by which the strain is put upon or released from the wire, and also for receiving a comparatively short retaining pin, which locks against the post through which the wire passes, and preserves the strain on the wire.

The method of using is as follows:—Supposing the fencing to be already erected, the end of the wire to be strained is unfastened and passed through the hole in the recessed part of my contrivance, so as to press it against the outer end of the post. The ends of two short levers are then placed in one of the holes on both of the enlarged ends of my roller, so as to revolve it, and are then removed from one to the other of such holes in succession, so as to wind the wire on the central recessed part. This is continued until the strain is sufficient, a short retaining pin is then placed in one of said holes, so as to press against the post, the levers are then removed and the contrivance allowed to remain there. If at any future time the wire requires to be again strained or slackened, it is only necessary to place either or both of said levers in the holes as before, remove the retaining pin, and either wind tighter or slacken at will.

My contrivance may be made either of metal or wood, as preferred; and of any size, although I prefer to make them of solid iron, about 5 inches long, $1\frac{1}{4}$ inch diameter at the ends, and 1 inch in the centre. I may make them tubular if I can obtain any material strong enough to bear the strain.

Referring to my drawings, figs. 1 and 2 show respectively face and end view of my contrivance, fig. 3 represents one of the levers for revolving it, and figure 4 one of the retaining pins, all full size, while fig. 5 shows on a smaller scale a perspective view of part of a post for wire fences representing the upper wire as having been strained, and the lower one as in the act of straining. AA are the enlarged ends of the roller, and B the recessed part. A' A' are the holes, which I prefer to make quite through the enlarged ends, although it is not absolutely necessary that they should go quite through. B' is the hole quite through the recessed part for the purpose of receiving and fastening the end of the wire to be strained. CC are the levers, and D the retaining pin.

On referring to the lower wire, it will be seen that its end has been passed through the hole B' and fastened, then the levers CC are placed alternately first in one hole, A', and then in the next, until the whole of the slack has been taken up, then one of the said levers is taken out, and a retaining-pin, D, inserted, as shown with respect to the upper wire, and so left until the tightened wire requires to be either slackened or re-tightened. When this is the case, the levers C must first be placed in the holes A', the retaining pin D removed, and the roller allowed or compelled to revolve in the required direction. After this object has been accomplished, and the wire re-strained, the retaining pin D is replaced as before. It will thus be seen that a boundary-rider simply needs to carry with him two of the levers C in order to adjust all the wire strainers on an estate.

If desired it may be so arranged that these rollers are fixed on opposite sides of the post, so as to equalize the strain, and it is to be noticed that unless the recess B is made in the rollers the wire will jamb between them and the post, and the ends of the rollers be forced away from them, so that without this recess the contrivance would be quite unworkable. I may also substitute cranked levers fitting in the ends of the rollers for the straight levers C, if I so desire.

Having thus described the nature of my invention, and the manner of performing same, I would have it understood that what I believe to be new, and therefore claim as of my invention, is—

Wire strainers consisting of a roller, hollow or solid, and having a recess in the centre, on which to wind the wire, and enlarged ends in which are holes to receive the ends of levers whereby to strain the wire, and afterwards to receive a retaining-pin, substantially as herein described and explained.

In witness whereof, I, the said Charles Osbern Ralph Walker, have hereto set my hand and seal, this twenty-eighth day of July, one thousand eight hundred and eighty-four.

Witness—

EDWD. WATERS,
Melbourne, Patent Agent.

CHARLES OSBERN RALPH WALKER.

This is the specification, marked A, referred to in the annexed Letters of Registration, granted to Charles Osbern Ralph Walker, the twenty-second day of October, A.D. 1884.

AUGUSTUS LOFTUS.

B.

ADDITION to the Specification of CHARLES OSBERN RALPH WALKER, of Coolart, Balnaring, in the Colony of Victoria, station manager, for an invention entitled "An improved Wire Strainer."

To the specification already deposited, I desire to add the sheet of drawing herewith, and the following description, in order that the nature and scope of my said invention may be more perfectly understood. Similar letters of reference to those used in my former drawing, denote similar parts upon the drawing now added thereto.

Figure 6 is a modification of the form of wire-straining contrivance shown in fig. 1, figs. 6^a and 6^b being sections on the lines *a a* and *b b* in fig. 6 respectively. As will be seen, this contrivance is hollow, and is provided with the holes A' for the turning lever, and in one or both ends, the hole B' joins or is a slot from a hole, A', and its hollow enlarged end and hollow body are so shaped that a crank handle might

be

An improved Wire Strainer.

be inserted through or partly through them, and the contrivance revolved thereby. Fig. 6^c shows the pin D when provided with a stop D¹ and a head D² the former for preventing its passage right through hole A¹, and the latter so that it may take a grip in the wood of the post.

Fig. 7 shows a further modification, and fig. 7^a a section of same on line *a a*, in fig. 7. In the enlarged ends A in this case I have square holes, A¹, one or more of which has a slot to hold end of the wire similarly to that in fig. 6, and I sometimes provide at one or both ends a slot B², shown by dotted lines through which the uncut end of a roll or coil of wire might be passed to enable the slack in it to be wound on the contrivance, the roll or coil being turned over to prevent twisting, the wire plugged, cut off when required length is ascertained, and then strained to finish, as before described. Fig. 7^b shows an alternate method of making one or both ends with a boss or head A², shaped for a spanner wrench or other turning contrivance. Fig. 7^c is an elevation of a lever C, for turning whose end will fit into whatever shaped hole A¹ is in enlarged end A, and in it is shown a "set off" C¹, to enable when used one way the hand of the workman to escape contact with a wire which might be above or below that one being strained, and when used at right angles to admit its insertion in the upper holes, when they are not perpendicular.

Fig. 8 shows the contrivance I have designed for use on iron standards and narrow posts, fig. 8^a being a section thereof on line *a a*, fig. 8, and fig. 8^b an elevation of a staple for holding it in place. In this case the holes A¹ are not made right through, being shown only to the depth of the head A, and on the inside of that head, but they may be right through, and they may be on the outside. The wire is fastened in hole B¹ and strained by the lever C in holes A¹, as before described, winding it on the barrel B, and the retaining staple D inserted in two of such holes from end to end of the contrivance, so that its bight or bend grasps while it bears against the post or standard, as shown in fig. 8^c.

The use of these contrivances is not confined to straining wires for fencing purposes, for they may be applied for wires for supporting vines, fruit trees, and other purposes, and among the advantages of such wire strainers is that no previous mechanical training is necessary to their proper use, and they are constructed so strong as to reduce the risk of breakage to a minimum; and my aim being to produce a simple and efficacious wire strainer to remain permanently affixed to the strained wire, I would have it understood that—

I further claim the modifications of said wire strainers, substantially as herein described and explained.

In witness whereof, I, the said Charles Osbern Ralph Walker, have hereto set my hand and seal, this fifteenth day of September, one thousand eight hundred and eighty-four.

Witness—

FRED. WALSH.

C. O. R. WALKER,
(By his Agent, J. E. BANKS).

This is the addition to the specification marked B, referred to in the annexed Letters of Registration, granted to Charles Osbern Ralph Walker, the twenty-second day of October, A.D. 1884.

AUGUSTUS LOFTUS.

REPORTS.

Sir,

Sydney, 18 August, 1884.

In reply to your blank cover of 31st July, transmitting Mr. Charles Osbern Walker's Petition for the registration of an "Improved Wire Strainer," we do ourselves the honor to report that we are unable to discover any novelty in the said invention that would justify us in recommending its registration.

We have, &c.,

E. C. CRACKNELL.
GOTHER K. MANN.

The Under Secretary of Justice.

Sir,

Sydney, 15 September, 1884.

In reply to your further blank cover of the 10th instant, *re* Mr. Charles Osbern Ralph Walker's Petition for the registration of an "Improved Wire Strainer," we do ourselves the honor to report that we are of opinion the prayer of the Petitioner may now be granted, in accordance with his revised drawings.

We have, &c.,

E. C. CRACKNELL.
GOTHER K. MANN.

The Under Secretary of Justice.

CHA^S WALKER'S PATENT.

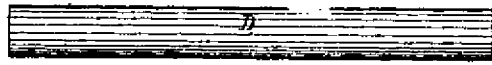


Fig. 4.

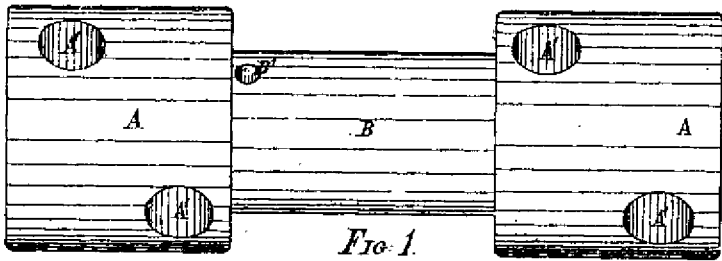


Fig. 1.

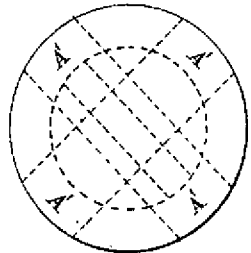


Fig. 2.



Fig. 3.

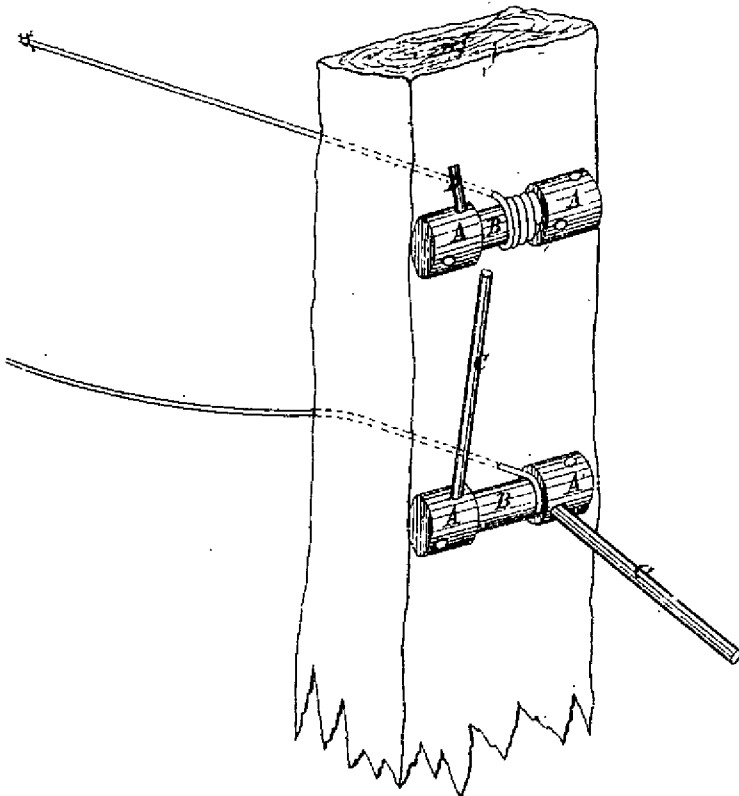


Fig. 5.

This is the Sheet of Drawings marked C referred to in the annexed Letters of Registration, granted to Charles Osborn, Ralph Walker, the twenty second day of October, A.D. 1884.

(Sig 245-)

Augustus Loftus.

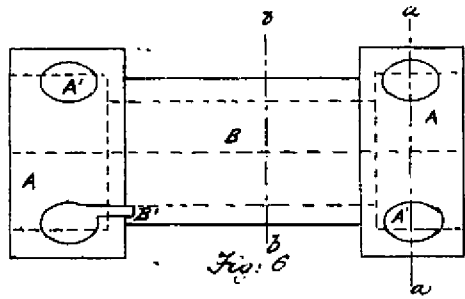


Fig. 6

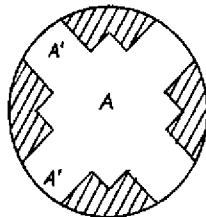


Fig. 6A

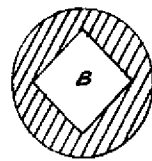


Fig. 6B

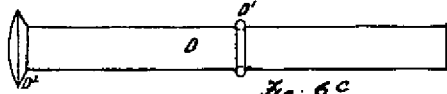


Fig. 6C

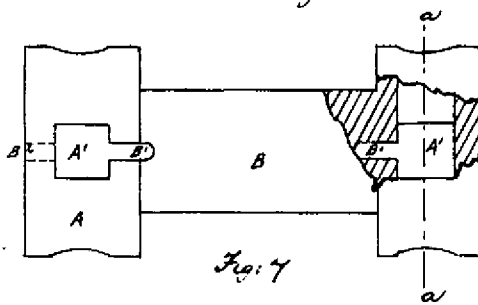


Fig. 7

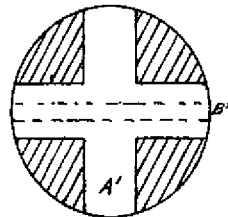


Fig. 7A

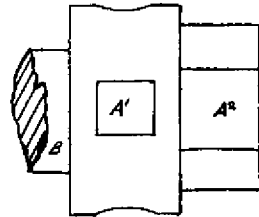


Fig. 7B

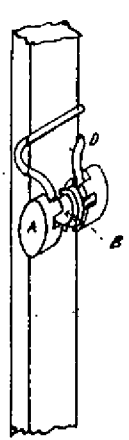


Fig. 8C

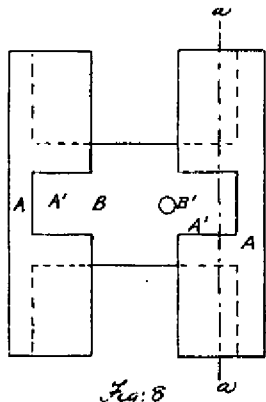


Fig. 8

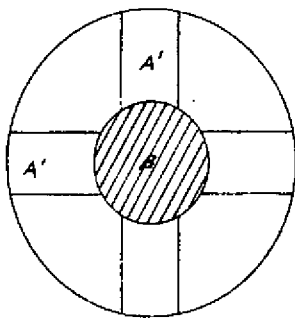


Fig. 8A

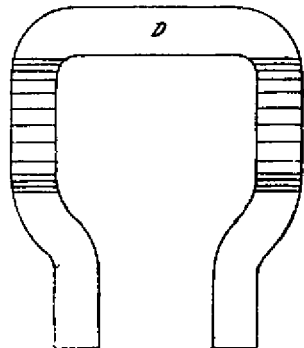


Fig. 8B

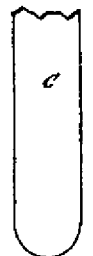


Fig. 7C

This is the Sheet of Drawings marked D referred to in the annexed Letters of Registration granted to Charles Osborn Ralph Walker, the twenty second day of October, A.D. 1884.

Augustus Loftus.



A.D. 1884, 23rd October. No. 1523.

A PROCESS CALLED "THE BERRYGRAPH."

LETTERS OF REGISTRATION to John Berry, for an invention entitled "A Process called the Berrygraph," for copying writings, plans, drawings, &c.

[Registered on the 24th day of October, 1884, in pursuance of the Act 16 Vic. No. 24.]

By HIS EXCELLENCY THE RIGHT HONORABLE SIR AUGUSTUS WILLIAM FREDERICK SPENCER LOFTUS (commonly called LORD AUGUSTUS LOFTUS), Knight Grand Cross of the Most Honorable Order of the Bath, a Member of Her Majesty's Most Honorable Privy Council, Governor and Commander-in-Chief of the Colony of New South Wales and its Dependencies.

TO ALL TO WHOM THESE PRESENTS SHALL COME, greeting :

WHEREAS JOHN BERRY, of Suva, Fiji, hath by his Petition humbly represented to me that he is the author or designer of a certain invention or improvement in manufactures, that is to say, of an invention entitled "A Process called 'The Berrygraph,'" for copying writings, plans, drawings, &c., which is more particularly described in the specification which is hereunto annexed ; and that he, the said Petitioner, hath deposited with the Honorable the Treasurer of the said Colony of New South Wales the sum of Twenty Pounds sterling, for defraying the expense of granting these Letters of Registration, as required by the Act of Council, sixteenth Victoria, number twenty-four ; and hath humbly prayed that I would be pleased to grant Letters of Registration, whereby the exclusive enjoyment and advantage of the said invention or improvement might be secured to him for a period of fourteen years : And I, being willing to give encouragement to all inventions and improvements in the arts or manufactures which may be for the public good, and having received a report favourable to the prayer of the said Petition, from competent persons appointed by me to examine and consider the matters stated therein and to report thereon for my information, am pleased, with the advice of the Executive Council, and in exercise of the power and authority given to me by the said Act of Council, to grant, and do by these Letters of Registration grant unto the said John Berry, his executors, administrators, and assigns, the exclusive enjoyment and advantage of the said invention or improvement, for and during the term of fourteen years from the date hereof ; to have, hold, and exercise unto the said John Berry, his executors, administrators, and assigns, the exclusive enjoyment and advantage thereof, for and during and unto the full end and term of fourteen years from the date of these presents next and immediately ensuing, and fully to be complete and ended : Provided always, that if the said John Berry shall not, within three days after the granting of these Letters of Registration, register the same in the proper office in the Supreme Court, at Sydney, in the said Colony of New South Wales, then these Letters of Registration, and all advantages whatsoever hereby granted, shall cease and become void.

In witness whereof, I have hereunto set my sign manual, and have caused the present Letters of Registration to be sealed with the seal of the said Colony of New South Wales, at Government House, Sydney, in New South Wales, this twenty-third day of October, in the year of our Lord, one thousand eight hundred and eighty-four.

[L.S.]

AUGUSTUS LOFTUS.

A Process called "The Berrygraph."

SPECIFICATION of John Berry, of Suva, Fiji, for a process entitled "Berrygraph."

THE object of my invention is to produce copies of writings, plans, designs, music, or drawings, with the accuracy of lithography, and at a lower cost of production than any other process of a similar kind now or heretofore in use.

My process is as follows:—

I take gelatine, glycerine, water, and bi-chromate of potash, and by the application of heat, I reduce these substances to a paste, which is then spread on the surface of paper or other suitable material. The proportions are one pound (1 lb.) each of glycerine, water, and gelatine, and one fluid ounce (1 oz.) of the bi-chromate of potash. These quantities may vary slightly.

For working, the following method is adopted:—The prepared paper, which will hereafter be called the Berrygraph, is soaked in cold water for a few minutes. It is then removed to a flat hard surface, after which, the original writing, drawing, &c., written in aniline or other suitable ink, is there to be placed face downwards on the prepared surface of the Berrygraph. The whole is then submitted to pressure in an ordinary letter or other press, by which a negative or reversed copy is produced on the face of the Berrygraph, from which a number of copies can be obtained.

The paper or other material to receive the copies should be damped to ensure a clear imprint from the Berrygraph, and to obtain perfect contact with the negative, a piece of felt, blanket, or other soft material, should be placed on the paper, and the whole then subjected to pressure in the same manner as original writing, drawing, &c.

Accompanying the Berrygraph is a portfolio designed for the purpose of (1) Providing a hard surface on which to place the Berrygraph; (2) Providing the soft material to give perfect contact.

Having described the nature of my invention, its manufacture, and mode of working, I will now proceed to enumerate the advantages it possesses. What I claim is—

1. That the Berrygraph process is superior in clearness, accuracy, and cheapness, to any other process of a similar kind now or heretofore in use.
2. That it produces in addition to copies of handwriting and music, copies of plans, designs, drawings, &c., to scale accuracy.
3. That its simplicity of working and low cost of production renders it available for all business purposes.
4. That it is cleanly in its working.
5. That it does not distort the plans, writings, drawings, &c., in any way, every copy being a *fac-simile* of the original.
6. That impressions can be taken directly from the Berrygraph into letter books, registers, &c., and on parchment, paper, leather, wood, or cloth.
7. That any alteration desired in the Berrygraph during the process of copying can be made by placing a negative of the required alteration on that portion of the Berrygraph to be altered.
8. That the writer or draughtsman has not to prepare the original in any special manner whereby the writing or drawing becomes altered from the natural way of writing or drawing.
9. That the original writing or drawing to be copied may be written on drawing, tracing, or writing paper, and tracing cloth, &c.
10. That the size of the plans, writings, &c., are limited only by the size of the press used.

In witness whereof, I, the said John Berry, have hereunto set my hand and seal, this —— day of August, one thousand eight hundred and eighty-four.

JOHN BERRY.

Witness—

GEO. DE C. REGO,
1, Koombanah Terrace,
Liberty-street, Enmore.

NOTE.—This specification is printed by the Berrygraph.

This is the specification referred to in the annexed Letters of Registration granted to John Berry, this twenty-third day of October, A.D., 1884.

AUGUSTUS LOFTUS.

REPORT.

Sir,

Sydney, 13 September, 1884.

The application of Mr. John Berry for Letters of Registration for an invention entitled "A process called the 'Berrygraph,'" for copying writings, plans, drawings, &c., having been referred to us, we have examined the specification and pattern accompanying the same, and have now the honor to report that we see no objection to the issue of Letters of Registration as applied for.

We have, &c.,
THOS. RICHARDS.
ARCH. C. FRAZER.

The Under Secretary of Justice.



A.D. 1884, 23rd October. No. 1524.

THE MAGIC CARPET AND WOOL CLEANER.

LETTERS OF REGISTRATION to Edward George Grace, for The Magic Carpet and Wool Cleaner.

[Registered on the 21th day of October, 1884, in pursuance of the Act 16 Vic. No. 24.]

BY HIS EXCELLENCY THE RIGHT HONORABLE SIR AUGUSTUS WILLIAM FREDERICK SPENCER LOFTUS (commonly called LORD AUGUSTUS LOFTUS), Knight Grand Cross of the Most Honorable Order of the Bath, a Member of Her Majesty's Most Honorable Privy Council, Governor and Commander-in-Chief of the Colony of New South Wales and its Dependencies.

TO ALL TO WHOM THESE PRESENTS SHALL COME, greeting:

WHEREAS EDWARD GEORGE GRACE, of the Sydney Carpet Grounds, Rushcutters' Bay, near Sydney, in the Colony of New South Wales, hath by his Petition humbly represented to me that he is the author or designer of a certain invention or improvement in manufactures, that is say, of an invention entitled "The Magic Carpet and Wool Cleaner," which is more particularly described in the specification which is herunto annexed; and that he, the said Petitioner, hath deposited with the Honorable the Treasurer of the said Colony of New South Wales the sum of Twenty Pounds sterling, for defraying the expense of granting these Letters of Registration, as required by the Act of Council, sixteenth Victoria, number twenty-four; and hath humbly prayed that I would be pleased to grant Letters of Registration, whereby the exclusive enjoyment and advantage of the said invention or improvement might be secured to him for a period of fourteen years: And I, being willing to give encouragement to all inventions and improvements in the arts or manufactures which may be for the public good, and having received a report favourable to the prayer of the said Petition, from competent persons appointed by me to examine and consider the matters stated therein and to report thereon for my information, am pleased, with the advice of the Executive Council, and in exercise of the power and authority given to me by the said Act of Council, to grant, and do by these Letters of Registration grant unto the said Edward George Grace, his executors, administrators, and assigns, the exclusive enjoyment and advantage of the said invention or improvement, for and during the term of fourteen years from the date hereof; to have, hold, and exercise unto the said Edward George Grace, his executors, administrators, and assigns, the exclusive enjoyment and advantage thereof, for and during and unto the full end and term of fourteen years from the date of these presents next and immediately ensuing, and fully to be complete and ended: Provided always, that if the said Edward George Grace shall not, within three days after the granting of these Letters of Registration, register the same in the proper office in the Supreme Court, at Sydney, in the said Colony of New South Wales, then these Letters of Registration, and all advantages whatsoever hereby granted, shall cease and become void.

In witness whereof, I have herunto set my sign manual, and have caused the present Letters of Registration to be sealed with the seal of the said Colony of New South Wales, at Government House, Sydney, in New South Wales, this twenty-third day of October, in the year of our Lord one thousand eight hundred and eighty-four.

[L.S.]

AUGUSTUS LOFTUS.

The Magic Carpet and Wool Cleaner.

SPECIFICATION of an application for Letters of Registration for the manufacture of a fluid to be known by the name of "Grace's Patent Magic Wool and Carpet Cleaner," which has been designed for the purpose of removing stains of every kind from silks, woollens, carpets, skins, rugs, mats, and wearing apparel, and for cleansing and polishing glass and silver, or plated articles, and to clean paint and furniture, also for use as a disinfectant, and with advantages as an addition to the bath, as it greatly tends to purify and soften the skin, thereby promoting health.

The articles required to be mixed together for the preparation of 20 gallons of the above-named fluid are as follows:—12 gallons of water; 3 lb. of soap; $\frac{1}{2}$ lb. of sal. soda; 1 oz. of blue; $\frac{1}{2}$ pint ether; 1 pint of benzine; 1 lb. borax; 6 ox galls; 3 grains arsenic; $\frac{1}{2}$ pint Condyl's fluid; $\frac{1}{2}$ pint spirits of ammonia; 1 oz. of salts of lemon, and so on in proportion for the manufacture of any larger quantity.

Directions for use:—Half a pint of the above fluid to one quart of water, applied with a sponge in the usual manner.

SPECIFICATION.

Articles for use of the Magic Carpet and Wool Cleaner.

Soap; sal. soda; blue; ether; benzine; borax; ox gall; arsenic; Condyl's liquid fluid; spirits of ammonia.

All to be used in equal parts with the exception of soap.

EDWARD GEORGE GRACE,
(By his Solicitor, G. ASHTON SHORTER).

This is the specification referred to in the annexed Letters of Registration, granted to Edward George Grace, the twenty-third day of October, A.D. 1884.

AUGUSTUS LOFTUS.

REPORT.

Sir,

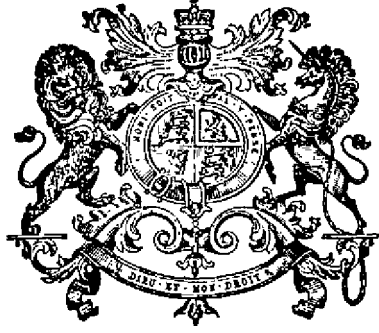
The application of Mr. Edward George Grace for Letters of Registration for an invention entitled "The Magic Carpet and Wool Cleaner," having been referred to us, we have examined the specification accompanying the same, and have now the honor to report that we see no objection to the issue of Letters of Registration as prayed for.

Sydney, 13 September, 1884.

We have, &c.,

JAMES BARNET.
CHARLES COWPER.

The Under Secretary of Justice.



A.D. 1884, 23rd October. No. 1525.

AN IMPROVED PORTABLE FLOATING APPARATUS FOR SLUICING ALLUVIAL
EARTHS.

LETTERS OF REGISTRATION to George Boulton Brown Elliott and Benjamin Poulton, for an Improved Portable Floating Apparatus for Sluicing Alluvial Earths.

[Registered on the 24th day of October, 1884, in pursuance of the Act 16 Vic. No. 24.]

BY HIS EXCELLENCY THE RIGHT HONORABLE SIR AUGUSTUS WILLIAM FREDERICK SPENCER LOFTUS (commonly called LORD AUGUSTUS LOFTUS), Knight Grand Cross of the Most Honorable Order of the Bath, a Member of Her Majesty's Most Honorable Privy Council, Governor and Commander-in-Chief of the Colony of New South Wales and its Dependencies.

TO ALL TO WHOM THESE PRESENTS SHALL COME, greeting :

WHEREAS GEORGE BOULTON BROWN ELLIOTT, of No. 2, Sydney Terrace, East Melbourne, in Colony of Victoria, timber merchant, and BENJAMIN POULTON, of Collins-street East, in the city of Melbourne aforesaid, homœopathic chemist, have by their Petition humbly represented to me that the Petitioner, the said George Boulton Brown Elliott, is the author or designer of a certain invention or improvement in manufactures, that is to say, of an invention entitled "An improved portable floating apparatus for sluicing alluvial earths," which is more particularly described in the specification and the sheet of drawings which are hereunto annexed; and that the Petitioner, the said Benjamin Poulton, is the assignee of three-fourths parts or shares of and in the said invention, so far as the Colony of New South Wales is concerned; and that they, the said Petitioners, have deposited with the Honorable the Treasurer of the said Colony of New South Wales the sum of Twenty Pounds sterling, for defraying the expense of granting these Letters of Registration, as required by the Act of Council, sixteenth Victoria, number twenty-four; and have humbly prayed that I would be pleased to grant Letters of Registration whereby the exclusive enjoyment and advantage of the said invention or improvement might be secured to them for a period of fourteen years: And I, being willing to give encouragement to all inventions and improvements in the arts or manufactures which may be for the public good, and having received a report favourable to the prayer of the said Petition from competent persons appointed by me to examine and consider the matters stated therein and to report thereon for my information, am pleased, with the advice of the Executive Council, and in exercise of the power and authority given to me by the said Act of Council, to grant, and do by these Letters of Registration grant unto the said George Boulton Brown Elliott and Benjamin Poulton, their executors, administrators, and assigns, the exclusive enjoyment and advantage of the said invention or improvement, for and during the term of fourteen years from the date hereof; to have, hold, and exercise unto the said George Boulton Brown Elliott and Benjamin Poulton, their executors, administrators, and assigns, the exclusive enjoyment and advantage thereof for and during and unto the full end and term of fourteen years from the date of these presents next and immediately ensuing, and fully to be complete and ended: Provided always, that if the said George Boulton Brown Elliott and Benjamin Poulton shall not, within three days after the granting of these Letters of Registration, register the same in the proper office in the Supreme Court, at Sydney, in the said Colony of New South Wales, then these Letters of Registration, and all advantages whatsoever hereby granted, shall cease and become void.

In witness whereof, I have hereunto set my sign manual, and have caused the present Letters of Registration to be sealed with the seal of the said Colony of New South Wales, at Government House, Sydney, in New South Wales, this twenty-third day of October, in the year of our Lord one thousand eight hundred and eighty-four.

[L.S.]

AUGUSTUS LOFTUS.

An Improved Portable Floating Apparatus for Sluicing Alluvial Earths.

SPECIFICATION of GEORGE BOULTON BROWN ELLIOTT, of No. 2, Sydney Terrace, East Melbourne, in the Colony of Victoria, timber merchant, and BENJAMIN POULTON, of Collins-street East, in the city of Melbourne, in the said Colony, homœopathic chemist, the said Benjamin Poulton being the assignee of three-fourths of an invention invented by the said George Boulton Brown Elliott, and entitled "An Improved Portable Floating Apparatus for Sluicing Alluvial Earths."

THIS invention has been designed for the purpose of providing a means for getting rid of the tailings where the alluvial earths to be treated are found in or by the side of the beds of creeks or rivers, and for enabling such means to be easily removed, so as to follow the course of the workings up stream.

We provide such means in the shape of a floating platform, floating sluice-boxes, and floating tail-races. The floating platform we set on an incline and support it on suitable framing from the deck of one or more punts. The floating sluice-boxes we attach to the lower end of the floating platform, and support them on floating buoys or punts, and the floating tail-races we attach to wells or troughs at the lower end of the floating sluices, and support them on buoys or punts also. The punts and buoys are of course anchored or moored. At the lower end of the inclined platform we erect a water-tank at a considerably higher level than the platform, and we balance this by an engine and its fuel at the opposite end of the punt or punts. We provide a centrifugal pump to raise the water from the river or creek into the elevated water-tank, and from it we conduct water-supply pipes, first, for conducting a supply to a series of perforated trays directly over perforated plates at the head of the sluice-boxes; second, for conducting a supply to the wells or troughs at the tail of the sluice-boxes and underneath a perforated false bottom therein; and thirdly, for conducting a supply to the head of each sluice. In the pipe leading to said troughs or wells we place a tap or cock, which we open and close alternately by suitable gearing, so as to give an intermittent flow to the water entering said wells or troughs in order to give a succession of pulsations to their contents.

Referring to our drawings, A is the inclined platform, B the sluice-boxes, and C the tail-races. A¹ is the framing for the platform, supported on punt D. E is the elevated water-tank, and F, G, and M the series of supply pipes therefrom. H is the centrifugal pump, and I the engine. The pipes F lead to perforated trays J, and the pipe G with its branches G¹ lead to the wells or troughs K, each of which has a perforated false bottom K¹, while the pipes M lead to the heads of the respective sluices, over each of which is a perforated plate L. B¹ and C¹ are the buoys or punts for the sluice-box and tail-race respectively. K² are hinged perforated plates for preventing large stones from falling into the wells or troughs K.

The mode of operation is as follows:—The alluvial earth to be treated is lifted and deposited on the platform A by any suitable means, but preferably we employ what are well known as Priestman's dredgers. This earth is then conveyed to the perforated plates L, either by shovelling or by means of a water jet playing upon it, and as it falls on to said plates it is subjected to the action of a shower of water from the upper trays J, which washes all the finer particles through the perforations in said plates L into the sluice-boxes B, which are of ordinary construction, the large stones remaining on said plates being then thrown out from time to time as required. The tailings from the sluice-boxes are subjected to a water pulsation or jigging in wells or troughs K, and the waste passes away through the tail-races C, which are made sufficiently long to prevent the tailings from returning back into the excavation being made by the dredger. When all the valuable alluvial earth has been excavated in one spot, the anchors or moorings are loosened and the whole apparatus floated farther up the stream and again moored, when operations are commenced afresh. By this means we are enabled to work river and creek beds, and to make artificial canals into alluvial flats on the banks of such rivers or creeks, where otherwise it would be impracticable, by reason of the almost impossibility of getting rid of the tailings at a sufficiently rapid rate.

We do not claim any novelty in any of the contrivances herein described and explained when taken separately and apart from each other, but what we believe to be new, and therefore claim as of our invention, is—

The construction of apparatus for sluicing alluvial earths on floating supports, in the manner and for the purpose substantially as herein described and explained.

In witness whereof, we, the said George Boulton Brown Elliott and Benjamin Poulton, have hereto set our hands and seals, this fourth day of September, one thousand eight hundred and eighty-four.

Witness—

EDWD. WATERS, Melbourne, Patent Agent.

GEO. B. B. ELLIOTT.
BENJN. POULTON.

This is the specification referred to in the annexed Letters of Registration granted to George Boulton Brown Elliott and Benjamin Poulton, the twenty-third day of October, A.D. 1884.

AUGUSTUS LOFTUS.

REPORT.

Sir,

In reply to your B.C. of 8th instant, forwarding a Petition for Letters of Registration from Messrs. Elliott and Poulton for an invention entitled "An improved portable floating apparatus for sluicing alluvial earth," we have the honor to inform you that having examined the drawings and specification accompanying the petition, we recommend that the prayer of the petitioners be acceded to.

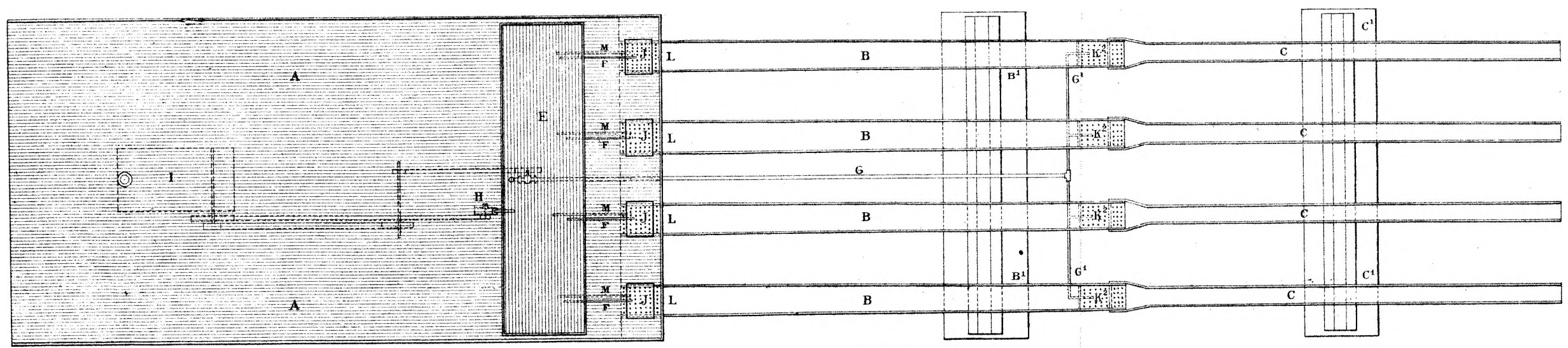
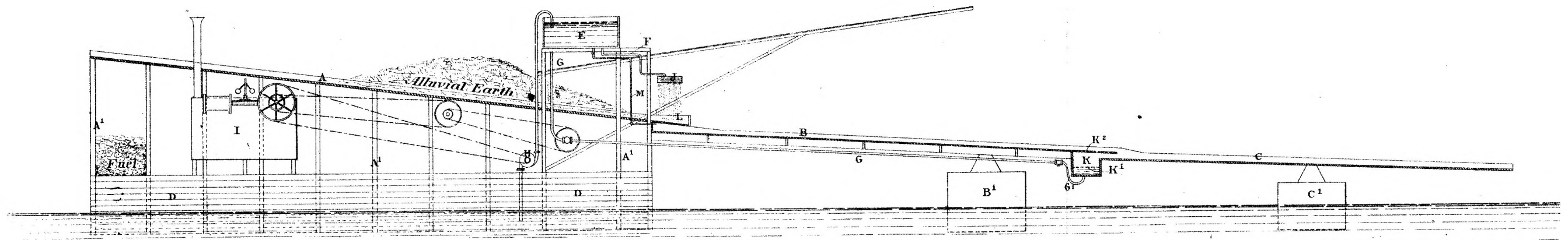
We have, &c.,

JOHN WHITTON.
E. O. MORIARTY.

The Under Secretary of Justice.

[Drawings—-one sheet.]

G. B. B. Elliott's Patent for
"An improved Portable Floating Apparatus for sluicing alluvial earths"



*This is the Sheet of Drawings referred to in the annexed
Letters of Registration granted to George Bolton Brown
Elliott, and Benjamin Poulton, the twenty third day of
October, A.D. 1884.
Augustus Loftus.*



A.D. 1884, 23rd October. No. 1526.

IMPROVEMENTS IN MACHINES FOR UPROOTING STUMPS AND TREES.

LETTERS OF REGISTRATION to John Walls, for an invention entitled
Improvements in Machines for Uprooting Stumps and Trees.

[Registered on the 24th day of October, 1884, in pursuance of the Act 16 Vic. No. 24.]

BY HIS EXCELLENCY THE RIGHT HONORABLE SIR AUGUSTUS WILLIAM FREDERICK SPENCER LOFTUS (commonly called LORD AUGUSTUS LOFTUS), Knight Grand Cross of the Most Honorable Order of the Bath, a Member of Her Majesty's Most Honorable Privy Council, Governor and Commander-in-Chief of the Colony of New South Wales and its Dependencies.

TO ALL TO WHOM THESE PRESENTS SHALL COME, greeting :

WHEREAS JOHN WALLS, of Camperdown, in the Colony of Victoria, blacksmith and carriage-builder, hath by his Petition humbly represented to me that he is the author or designer of a certain invention or improvement in manufactures, that is to say, of an invention entitled "Improvements in machines for uprooting stumps and trees," which is more particularly described in the specification and the sheet of drawings which are hereunto annexed ; and that he, the said Petitioner, hath deposited with the Honorable the Treasurer of the said Colony of New South Wales the sum of Twenty Pounds sterling, for defraying the expense of granting these Letters of Registration, as required by the Act of Council, sixteenth Victoria, number twenty-four ; and hath humbly prayed that I would be pleased to grant Letters of Registration, whereby the exclusive enjoyment and advantage of the said invention or improvement might be secured to him for a period of fourteen years : And I, being willing to give encouragement to all inventions and improvements in the arts or manufactures which may be for the public good, and having received a report favourable to the prayer of the said Petition, from competent persons appointed by me to examine and consider the matters stated therein and to report thereon for my information, am pleased, with the advice of the Executive Council, and in exercise of the power and authority given to me by the said Act of Council, to grant, and do by these Letters of Registration grant unto the said John Walls, his executors, administrators, and assigns, the exclusive enjoyment and advantage of the said invention or improvement, for and during the term of fourteen years from the date hereof ; to have, hold, and exercise unto the said John Walls, his executors, administrators, and assigns, the exclusive enjoyment and advantage thereof, for and during and unto the full end and term of fourteen years from the date of these presents next and immediately ensuing, and fully to be complete and ended : Provided always, that if the said John Walls shall not, within three days after the granting of these Letters of Registration, register the same in the proper office in the Supreme Court, at Sydney, in the said Colony of New South Wales, then these Letters of Registration, and all advantages whatsoever hereby granted, shall cease and become void.

In witness whereof, I have hereunto set my sign manual, and have caused the present Letters of Registration to be sealed with the seal of the said Colony of New South Wales, at Government House, Sydney, in New South Wales, this twenty-third day of October, in the year of our Lord one thousand eight hundred and eighty-four.

[L.S.]

AUGUSTUS LOFTUS.

Improvements in Machines for uprooting Stumps and Trees.

SPECIFICATION of JOHN WALLS, of Camperdown, in the Colony of Victoria, blacksmith and carriage-builder, for an invention entitled "Improvements in machines for uprooting stumps and trees."

THIS invention consists of a series of improvements on those kinds of machines for uprooting stumps and trees, in which the strain is obtained by means of a lever acting on movable pins in a perforated fulcrum or anchor-plate, and commonly known as "Forest Devils."

My first improvement consists in putting four rows of holes in the perforated fulcrum or anchor-plate, instead of two, so as to enable a more or less powerful purchase to be obtained, and a shorter or longer stroke. This is for the purpose of accommodating the machine to the work it has to perform, that is to say, if the resistance of the tree or stump is great, the shorter stroke and more powerful purchase can be used, but if the resistance is considerably less, the longer stroke and less powerful purchase can be used, and as either one or other can be used by simply changing the pins to the outer or inner holes, it follows that the greater power and the shorter stroke can be used until the stump or tree loosens its grip on the ground, and then the lesser power and the longer stroke can be used to finish off the work quickly, or the longer stroke may be used after the connections are completed, so as to take in the slack and bring the chain on the tree in about one third of the time occupied by the inner rows.

My second improvement consists in putting two holes, preferably oval, in the lever, in addition to the two ordinary open grips, so as to provide for the different purchases and strokes alluded to in the previous paragraph. In my machine the open grips are placed further apart than usual. By doing away with the open grips, and retaining the oval holes, my lever could be used with the ordinary "Forest Devils," and would be a great improvement to them, as the breaking of the double rod by overshooting the holes in the plate would be altogether prevented.

My third improvement consists of a jointed retaining rod, having hooks at either end, and another hook between them at one of the joints of the said rod, so as to enable the lever to be relieved of the strain when it has reached the butt end of the anchor-plate, and has to be returned to its starting place at the other end of said plate. The novelty consists in making it jointed with a hook at one of the joints, so as to enable the hauling chain to be gripped at any convenient point, while the lever is being slid back to its starting point.

Referring now to my drawings—Fig. 1 shows plan or top view of my improved tree and stump extractor in working position, and figures 2 and 3 side views of the haulage rod and lever. Fig. 4 shows views of the fulcrum pins, and fig. 5 shows the strain retaining rod D, which is an auxiliary to the tree extractor. Fig. 6 shows the shackle for attaching above to the fulcrum plate. Fig. 7 shows a general view of tree extractor, with the strain retaining rod in position between haulage chain and fulcrum plate.

In these figures, A is the metal fulcrum or anchor-plate, having four rows of holes formed lengthwise along it, the inner pair of rows A¹ being made to suit the two oval holes B¹, and the outer pair of rows A² to suit the two open grips B², which are provided in the cheeks of the lever B. The pins A³ fit in the holes A¹ and A², and form the pivot for the time being on which the lever works. At the outer ends of the fulcrum plate A are two oblong holes A⁴ and A⁵, which are for the purpose of attaching it to a suitable anchorage or otherwise. The lever B has pintles B³ projecting from its outer cheeks as a means for securing the double metal haulage rod C thereto.

The mode of operation is as follows:—Supposing the fulcrum plate A to be fixed to an anchorage, the haulage chain from the tree about to be pulled down being secured to the looped end of the double haulage rod C and the lever B in the position indicated by dotted lines in fig. 1, and full lines in fig. 7, which shows the inner rows of holes in use, and the fulcrum pin inserted in the upper hole through the lever B and the fulcrum plate A, then the lever is forced towards the anchor end until such time as the nearer hole B¹ in said lever is opposite to the next hole in fulcrum plate, when another pin is inserted and the other removed, and the lever is then forced towards the haulage end, and so on, backwards and forwards, until the fulcrum plate is traversed or the tree pulled down. When sufficient power is at hand, or when the strain is not so great, as for instance, after the tree has "started," or passed over its equilibrium, the outer rows of holes A² that correspond with the open grips B² in the lever may be used. This position is shown in full lines in fig. 1, and is worked similarly to the inner row above described, but in this case it will be noticed that the fulcrum plate is traversed in about one third of the time occupied by the inner rows. In cases where the strain is not sufficient to extract the tree by one traverse of the fulcrum plate, and it is required to shift the lever again back to the starting end, then to retain the strain during such time between the haulage chain and fulcrum plate, my strain retaining rod D, is used, as shown in fig. 7, when the most convenient of the small hooks D² are placed in the shackle A⁵, attached to the fulcrum plate A (or the hooks may be inserted in any of the end holes in said plate, if practicable), and the large hooks D¹ at the other end are placed in any convenient link in the haulage chain E, thereby retaining the strain until the lever has been shifted and the double haulage rod C again made fast to its chain, when the straining operation is again repeated and the strain retaining rod becomes relieved.

Having thus described the nature of my invention, and the manner of performing same, I would have it understood that what I claim as my improvements in machines for uprooting stumps and trees is—

First—Making four rows of holes lengthwise along the edge of the fulcrum or anchor-plate, substantially as and for the purpose herein described and explained.

Second—Making two holes in that end of the lever which travels over the fulcrum or anchor-plate, in addition to the two ordinary open grips, as and for the purpose herein described and explained.

Third—Making the strain retaining rod in joints with hooks at each end, and another or others at intervals between them, substantially as and for the purpose herein described and explained.

In witness whereof, I, the said John Walls, have hereto set my hand and seal, this eighth day of September, one thousand eight hundred and eighty-four.

Witness—

ARTHUR SPEED, Solicitor, Camperdown.

JOHN WALLS.

This is the specification referred to in the annexed Letters of Registration, granted to John Walls, the twenty-third day of October, A.D. 1884.

AUGUSTUS LOFTUS.

REPORT.

Improvements in Machines for uprooting Stumps and Trees.

REPORT.

Sir,

In reply to your B.C. of 13th instant, forwarding a petition from Mr. John Walls, for Letters of Registration for an invention entitled "Improvements in machines for uprooting stumps and trees," we have the honor, after examination of the drawings and specification accompanying the petition, to recommend that Letters of Registration be granted in accordance with the prayer of the petitioner.

Sydney, 20 September, 1884.

We have, &c.,

JOHN WHITTON.
E. O. MORIARTY.

The Under Secretary of Justice.

[Drawings—one sheet.]

John Walls' Patent

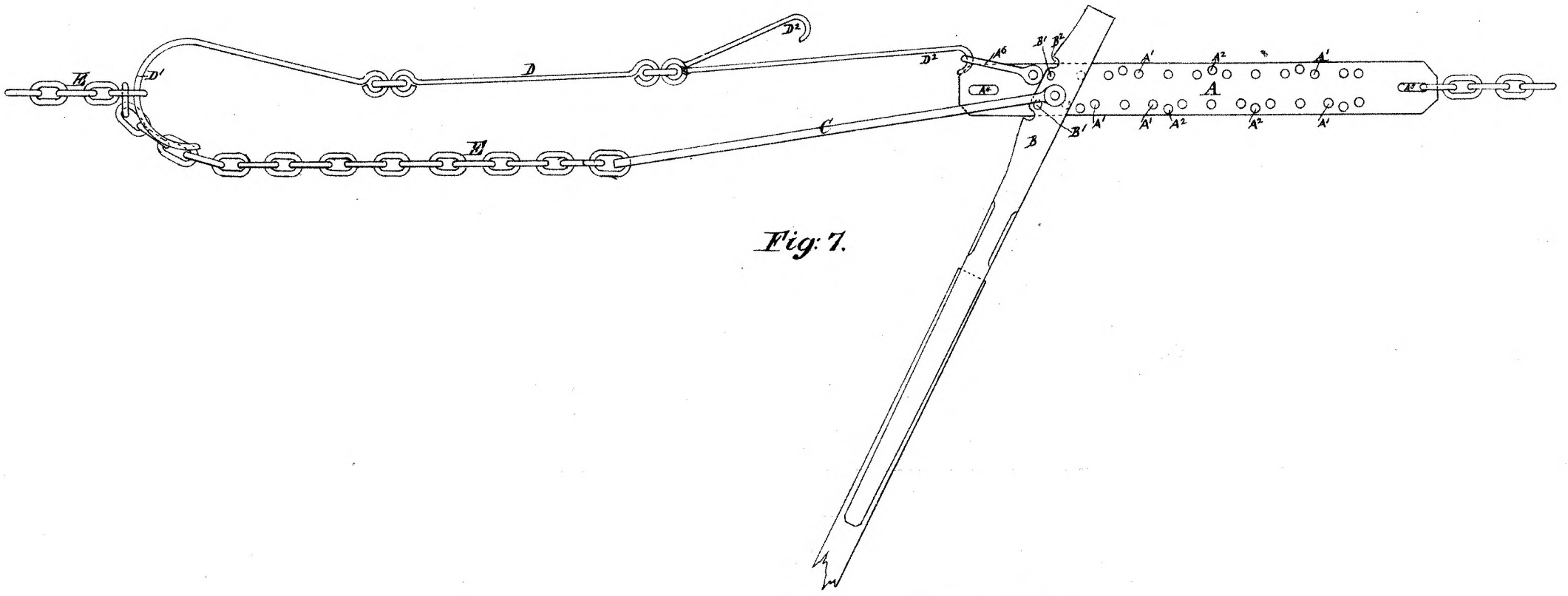


Fig. 7.

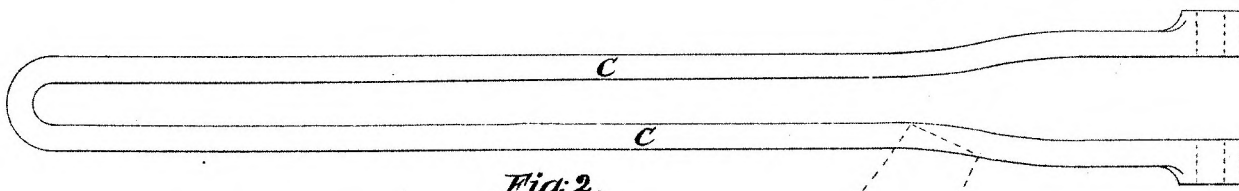


Fig. 2.

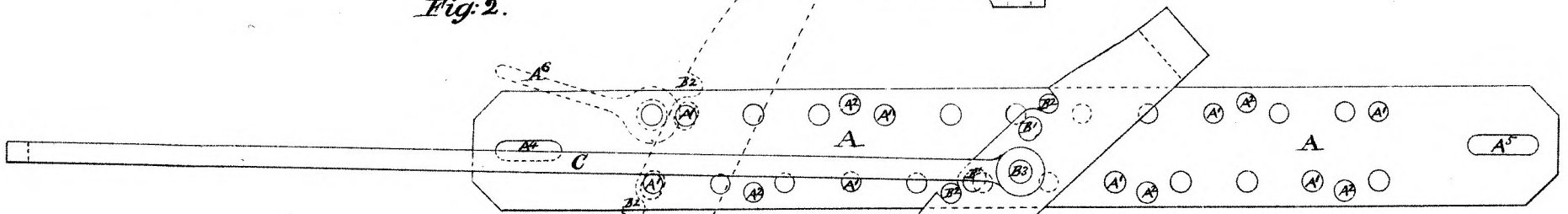


Fig. 1.

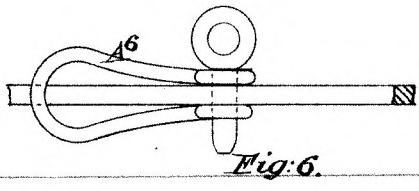


Fig. 6.

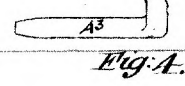


Fig. 4.

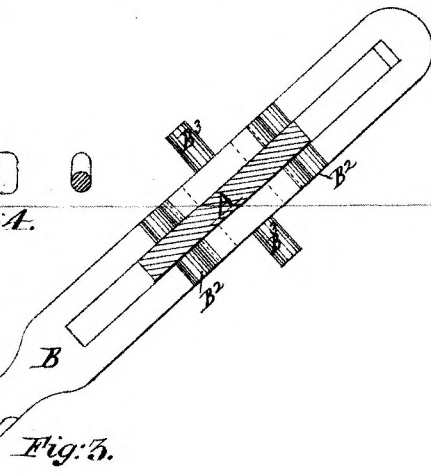


Fig. 3.

This is the Sheet of Drawings referred to in the annexed Letters of Registration granted to John Walls, the twenty third day of October, A.D. 1884.

Augustus Loftus.

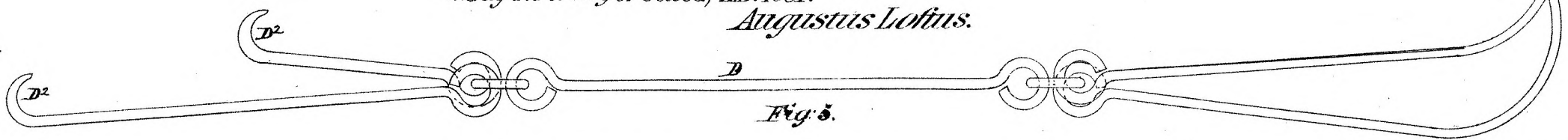


Fig. 5.



A.D. 1884, 23rd October. No. 1527.

AN IMPROVED TICKET-HOLDER.

LETTERS OF REGISTRATION to William Morton Stevenson, for an Improved Ticket-holder.

[Registered on the 24th day of October, 1884, in pursuance of the Act 16 Vic. No. 24.]

BY HIS EXCELLENCY THE RIGHT HONORABLE SIR AUGUSTUS WILLIAM FREDERICK SPENCER LOFTUS (commonly called LORD AUGUSTUS LOFTUS), Knight Grand Cross of the Most Honorable Order of the Bath, a Member of Her Majesty's Most Honorable Privy Council, Governor and Commander-in-Chief of the Colony of New South Wales and its Dependencies.

TO ALL TO WHOM THESE PRESENTS SHALL COME, greeting :

WHEREAS WILLIAM MORTON STEVENSON, of Rundle-street, Adelaide, hath by his Petition humbly represented to me that he is the author or designer of a certain invention or improvement in manufactures, that is to say, of an invention entitled "An Improved Ticket-holder," which is more particularly described in the specification and the sheet of drawings which are hereunto annexed; and that he, the said Petitioner, hath deposited with the Honorable the Treasurer of the said Colony of New South Wales the sum of Twenty Pounds sterling, for defraying the expense of granting these Letters of Registration, as required by the Act of Council, sixteenth Victoria, number twenty-four; and hath humbly prayed that I would be pleased to grant Letters of Registration, whereby the exclusive enjoyment and advantage of the said invention or improvement might be secured to him for a period of fourteen years: And I, being willing to give encouragement to all inventions and improvements in the arts or manufactures which may be for the public good, and having received a report favourable to the prayer of the said Petition, from competent persons appointed by me to examine and consider the matters stated therein and to report thereon for my information, am pleased, with the advice of the Executive Council, and in exercise of the power and authority given to me by the said Act of Council, to grant, and do by these Letters of Registration grant unto the said William Morton Stevenson, his executors, administrators, and assigns, the exclusive enjoyment and advantage of the said invention or improvement, for and during the term of fourteen years from the date hereof; to have, hold, and exercise unto the said William Morton Stevenson, his executors, administrators, and assigns, the exclusive enjoyment and advantage thereof, for and during and unto the full end and term of fourteen years from the date of these presents next and immediately ensuing, and fully to be complete and ended: Provided always, that if the said William Morton Stevenson shall not, within three days after the granting of these Letters of Registration, register the same in the proper office in the Supreme Court, at Sydney, in the said Colony of New South Wales, then these Letters of Registration, and all advantages whatsoever hereby granted, shall cease and become void.

In witness whereof, I have hereunto set my sign manual, and have caused the present Letters of Registration to be sealed with the seal of the said Colony of New South Wales, at Government House, Sydney, in New South Wales, this twenty-third day of October, in the year of our Lord one thousand eight hundred and eighty-four.

[L.S.]

AUGUSTUS LOFTUS.

Improved Ticket-holder.

TO ALL TO WHOM THESE PRESENTS SHALL COME: I, WILLIAM MORTON STEVENSON, of Rundle-street, Adelaide, watchmaker, send greeting:

WHEREAS I, the said William Morton Stevenson, am the inventor of certain improvements for "An Improved Ticket-holder": Now, know ye that I, the said William Morton Stevenson, do hereby declare the nature of my said improvements, and in what manner the same are to be performed, to be particularly described and ascertained in and by the following statement, that is to say, my invention consists of a simple contrivance for holding and delivering tramway, railway, or other tickets or cards, and its general construction and mode of working are clearly demonstrated in the drawing deposited herewith. I will, however, briefly describe it. My ticket-holder may be made of silver, gold, or any other metal, and also of wood, papier-mache, vulcanite, or similar material, and of course of variable dimensions, to suit the sizes of tickets or cards which it is desired to carry. It may also be worn by ladies and gentlemen as a piece of jewellery for personal adornment, or may be carried in the pocket like an ordinary match or ticket box. The principle of my invention, however, is clearly demonstrated in the drawing herewith, and that may be applied to holders of great variety in size and shape and general ornamentation. I make a case A, of the shape and size desired, and in the lower part I fix one or more springs B, to which I attach a stage C, which it will be seen moves up and down in the slots D, shown, and upon this stage the tickets intended to be used are placed. The lid or top E, it will be observed, is slotted, and on the under side I affix a piece of spring metal F, which, at the delivery end G, is notched with teeth, and this delivery spring is operated by one or more studs H, which work in the slot I. At the delivery end of the box is a small aperture J, and wide enough to admit the passage of one ticket at a time. The method of working my invention is as follows:—The tickets having been placed in the box, the lid is closed down, and fits tightly, or where the case is made in one piece, without a lid, the tickets or cards are deposited in the box, as shown in the drawing, through the end K, which is pulled down to admit them, and, by the pressure of the springs, automatically closes when the tickets or cards are in. When a ticket is wanted you press the stud or studs, and immediately the upper ticket is gripped by the toothed delivery spring and forced out of the aperture, and this operation may be repeated until the stock of tickets is exhausted.

CLAIM.

Having fully ascertained and described my invention, and the manner in which it is worked, I wish it to be understood that what I wish protected by Letters Patent as my invention is a box or case fitted with appliances and attachments, substantially as described and shown in the drawing deposited herewith, for the purpose of holding and delivering tramway, railway, or other tickets and cards. I do not confine myself to any exact sizes or shapes, as it will be evident that the exterior shape and design of the box may be varied considerably, while at the same time adhering to the internal mechanism therein described.

In witness hereof, I have hereunto set my hand and seal, this fifth day of September, in the year of our Lord one thousand eight hundred and eighty-four.

Witness—

JNO. FAIRFAX CONIGRAVE,
Licensed Patent Agent.

W. M. STEVENSON.

This is the specification referred to in the annexed Letters of Registration granted to William Morton Stevenson, the 23rd day of October, A.D. 1884.

AUGUSTUS LOFTUS.

To His Excellency the Governor of the Colony of New South Wales.

The humble Petition of William Morton Stevenson, of Rundle-street, Adelaide, watchmaker, respectfully sheweth,—

That I am in possession of an invention for "An Improved Ticket-holder," which I believe will be of great public utility.

That I am the true and first inventor thereof, and that the said invention is not in use by any other person or persons to the best of my knowledge or belief.

That I have paid into Her Majesty's Treasury, at Sydney, the sum of £20, as provided by the Patent Act.

I therefore humbly pray that Your Excellency will be pleased to grant unto me, my executors, and assigns, Letters of Registration for the sole use, benefit, and advantage of my said invention within the Colony of New South Wales, for the term of fourteen years, pursuant to an Act of Parliament of the said Colony in that case made and provided.

And your Petitioner, as in duty bound, will every pray.

In witness whereof, I have hereunto set my hand and seal, this fifth day of September, in the year of our Lord one thousand eight hundred and eighty-four.

Witness—

JNO. FAIRFAX CONIGRAVE,
Licensed Patent Agent.

W. M. STEVENSON.

REPORT.

Sir,

Sydney, 20 September, 1884.

In reply to your B.C. of the 12th instant, forwarding a petition from Mr. W. M. Stevenson for Letters of Registration for an invention entitled "An Improved Ticket-holder," we have the honor to recommend, having examined the drawings and description accompanying the Petition, that Letters of Registration be issued to the Petitioner, in terms of the prayer of the Petition.

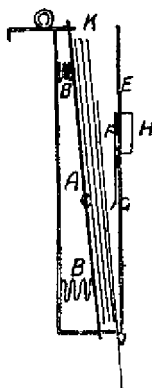
We have, &c.,

JOHN WHITTON.
E. O. MORIARTY.

The Under Secretary of Justice.

[Drawings—one sheet.]

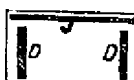
Sectional View.



Top view



End view



Natural size.

To hold ordinary Tram ticket.

(Sig 245-)

*This is the Sheet of Drawings referred to in the annexed
Letters of Registration, granted to William Morton
Stevenson, the twenty third day of October, A.D. 1884.
Augustus Loftus.*



A.D. 1884, 23rd October. No. 1528.

IMPROVEMENTS IN INTERLOCKING APPARATUS.

LETTERS OF REGISTRATION to Robert Archibald White, Arthur Lucas Harrold, and Walter Frampton, for Improvements in Interlocking Apparatus.

[Registered on the 24th day of October, 1884, in pursuance of the Act 16 Vic. No. 24.]

BY HIS EXCELLENCY THE RIGHT HONORABLE SIR AUGUSTUS WILLIAM FREDERICK SPENCER LOFTUS (commonly called LORD AUGUSTUS LOFTUS), Knight Grand Cross of the Most Honorable Order of the Bath, a Member of Her Majesty's Most Honorable Privy Council, Governor and Commander-in-Chief of the Colony of New South Wales and its Dependencies.

TO ALL TO WHOM THESE PRESENTS SHALL COME, greeting :

WHEREAS ROBERT ARCHIBALD WHITE, of Boulah Road, Norwood, in the province of South Australia, civil and mechanical engineer, ARTHUR LUCAS HARROLD, of Adelaide, in the said province, merchant, and WALTER FRAMPTON, of Adelaide aforesaid, gentleman, have by their Petition humbly represented to me that the petitioner, the said Robert Archibald White, is the author or designer of a certain invention or improvement in manufactures, that is to say, of an invention entitled "Improvements in Interlocking Apparatus," which is more particularly described in the specification and the sheet of drawings which are hereunto annexed ; and that the petitioners, the said Arthur Lucas Harrold and Walter Frampton, are each the assignee of one fourth part or share of and in the said invention so far as the Colony of New South Wales is concerned ; and that they, the said Petitioners, have deposited with the Honorable the Treasurer of the said Colony of New South Wales the sum of Twenty Pounds sterling, for defraying the expense of granting these Letters of Registration, as required by the Act of Council, sixteenth Victoria, number twenty-four ; and hath humbly prayed that I would be pleased to grant Letters of Registration, whereby the exclusive enjoyment and advantage of the said invention or improvement might be secured to them for a period of fourteen years ; And I, being willing to give encouragement to all inventions and improvements in the arts or manufactures which may be for the public good, and having received a report favourable to the prayer of the said Petition from competent persons appointed by me to examine and consider the matters stated therein and to report thereon for my information, am pleased, with the advice of the Executive Council, and in exercise of the power and authority given to me by the said Act of Council, to grant, and do by these Letters of Registration grant unto the said Robert Archibald White, Arthur Lucas Harrold, and Walter Frampton, their executors, administrators, and assigns, the exclusive enjoyment and advantage of the said invention or improvement, for and during the term of fourteen years from the date hereof ; to have, hold, and exercise unto the said Robert Archibald White, Arthur Lucas Harrold, and Walter Frampton, their executors, administrators, and assigns, the exclusive enjoyment and advantage thereof, for and during and unto the full end and term of fourteen years from the date of these presents next and immediately ensuing, and fully to be complete and ended : Provided always, that if the said Robert Archibald White, Arthur Lucas Harrold, and Walter Frampton, shall not, within three days after the granting of these Letters of Registration, register the same in the proper office in the Supreme Court, at Sydney, in the said Colony of New South Wales, then these Letters of Registration, and all advantages whatsoever hereby granted, shall cease and become void.

In witness whereof, I have hereunto set my sign manual, and have caused the present Letters of Registration to be sealed with the seal of the said Colony of New South Wales, at Government House, Sydney, in New South Wales, this twenty-third day of October, in the year of our Lord one thousand eight hundred and eighty-four.

[L.S.]

AUGUSTUS LOFTUS.

Improvements in Interlocking Apparatus.

SPECIFICATION of ROBERT ARCHIBALD WHITE, of Beulah Road, Norwood, in the province of South Australia, civil and mechanical engineer, ARTHUR LUCAS HARROLD, of Adelaide, in the said province, merchant, and WALTER FRAMPTON, of Adelaide aforesaid, gentleman, (the said Arthur Lucas Harrold and Walter Frampton) being each the assignee of one fourth part or share of and in an invention invented by the said Robert Archibald White, and entitled "Improvements in Interlocking Apparatus."

This invention consists of certain improvements in interlocking apparatus, for working points, switches, signals, and any other contrivances required to be similarly operated, by which improvements the motion is conveyed directly from the catch rods to the interlocking devices, instead of indirectly, as in all other apparatus of a similar character. It relates mainly to the catch rod, the quadrant, the slotted cylinder, and its actuating locks, and also to the slide bars, slide bar racks, and slide bar guides. The lower part of the catch rod is so constructed as to work in a slotted hole made at the proper place in the radial centre line of the operating lever, and both the lever and the lower part of the catch rod work in a slot formed in the operating or canting quadrant, which, together with its attached slotted cylinder, is caused to have a side canting motion by the action of said catch rod on the suitably formed surface of the slot at the ends of the quadrant, and which quadrant, when canted, blocks the operating lever at one or other of its ends. The parts of the canting quadrant which are used to block the lever at either end are made vertical, and not radial or perpendicular, to the pivot of the lever, and that part of the lever which travels through the quadrant is swelled out, so that its front when from the man is vertical, and its back when to the man is vertical. This is done because each and every vertical section of the quadrant revolves in a vertical line. The quadrants oscillate or cant in suitable bearings. The lower part of the catch rod has four projections, two on each side, the two on one side actuating the quadrant at the front, and the two on the other side actuating it at the back. The lower part of the catch rod is made to fit into the slot in the lever, and is kept in such slot by the two ribs on such catch rod, and also by the inner surfaces of the slot in the quadrant. The centre line of the catch rod is radial with the pivot of the operating lever, in order that its action, when raised or lowered, may be exactly radial to the pivot of the lever. The upper part of such catch rod has the well-known ordinary bent lever pivoted on the operating lever, and is attached to the lower part by two side bars, one on each side of the operating lever, and which two side bars may be made adjustable as regards their length. The catch rod is fitted with a pair of spiral springs at its lower end to return it to its normal position, and also may be fitted with a pedal lever to be used either with or without the ordinary bent lever at top, which pedal lever is also supplied with either a spring or weight to return it to its normal position. Firmly attached to the quadrants are slotted cylinders whose length will be determined by the number of slide bars and their width apart, and into such slotted cylinders are fitted toothed actuating locks which gear into racks fixed on the slide bars. Attached to the quadrant bearers are racks notched at top and bottom for carrying and guiding the slide bars. Each slide bar is preferably constructed of two thin bars with the locking and releasing locks, and slide bar guides between them, and which thin bars are firmly held together by such locks and slide bar guides and their bolts, set screws, or rivets. Instead of constructing each slide bar of two thin bars, it may be made of one solid bar with the locks bolted or riveted to it. The length of each slide bar will be determined by the number and distance apart of the levers it has to interlock. On each slide bar is attached all locking and releasing locks, and provided with the necessary number of slide bar guides. The combination of notched racks, slide bars, each constructed of two bars as aforesaid, and slide bar guides, enables any one slide bar to be removed either from the top or bottom rack without disturbing the remainder, and also enables any single lock to be removed, thus facilitating any necessary repairs or transposition of the interlocking. The actuating locks are prevented from getting out of gear by the slide bar guides. The locking and releasing locks are made of the necessary shape to travel into and out of the slotted cylinders, and in some cases such locking or releasing locks are constructed to act also as slide bar guides.

Referring to the drawings,—figure 1 illustrates a side elevation of my apparatus, showing the first lever with its catch rod up, and consequently the oscillating or canting quadrant in its vertical position ready to allow the lever to pass through or traverse the quadrant longitudinally, and the attached slotted cylinder released of its ordinary locks. In this figure the lever is shown in full lines in its normal position, or when from the man, and in dotted lines in its abnormal position, or when to the man; it shows the contrivance for working the catch rod by hand only.

Figure 2 shows a front view of five levers attached and pivoted in suitable framing, the first of which levers is complete. The cross-section of the quadrant here shown is taken on a line immediately in front of the lever, as at J K, figure 4, when the catch rod is down, and consequently canting said quadrant to the position shown, so blocking the lever from the man. The remaining levers are broken so as to illustrate the catch rod and quadrant in the following positions, viz. :—No. 2 shows a cross-section of the quadrant at the catch rod or immediately on the centre line of the lever, as at L M, figure 4, which lever with its catch rod and quadrant are in the same positions as described with reference to No. 1. No. 3 shows a cross-section through the quadrant at same position as No. 2, but in this case the catch rod is raised so as to bring the quadrant to its vertical position. Nos. 4 and 5 are similar views to 2 and 1, when the lever has been pulled to the man, or to its abnormal position, and the catch rod lowered, thereby canting said quadrant in a reverse direction, and consequently blocking the lever to the man, the former being a section at C D, and the latter at E F, figure 4.

Figure 3 is a plan showing the arrangement of the quadrants, slotted cylinders, and slide bars for five levers. The centre quadrant is in its vertical position, the two on the right-hand side are canted so as to block the lever to the man, and the two on the left canted so as to block the lever from the man.

Figures 4 and 5 are respectively a side view and plan of the quadrant in its vertical position, and slotted cylinder as fixed together in working position; and figure 6 shows a series of cross-sections of the same at the corresponding positions indicated by the letters *a*, *b*, *c*, *d*, *e*, *f*, and *g*. The respective cross sections of the quadrant as are follows, viz. :—*a* is at centre of lever when from man with catch rod down. *b* is at centre of lever when from man with catch rod up; *c* is at front of lever when from man with catch rod down and lever blocked; *d* is at centre of quadrant with catch rod up; *e* is at back of lever when to man with catch rod down; *f* is at centre of lever when to man with catch rod up; *g* is at centre of lever when to man with catch rod down.

Figure

Improvements in Interlocking Apparatus.

Figure 7 is a back view of the lever with its attachments, as shown in figure 1, and figures 8, 9, 10, and 11 are side views of the same, showing the four different methods for operating the catch rod. In figures 8 and 9 the catch rod is risen by the hand lever, but in figure 8 it is shown with spiral springs B^2 for pulling it back to its normal position, while in figure 9 the weighted lever C^1 accomplishes the same object. In figures 10 and 11 the hand lever A^2 is dispensed with, and the catch rod is lifted by the action of the foot lever C . In the former case, however, it is pulled down by the coiled springs B^2 , and in the latter by the weight C^2 on lever C^2 , which is a continuation of foot lever C .

Figures 12, 13, and 14 show to a larger scale transverse sections through the slotted cylinders 1^a , 2^b , 3^c , and 4^d in their positions between the slide bars H^1 H^2 . They also show the guide bars G^1 for supporting same, and the actuating racks K , and ordinary locks K^1 , which are fixed to the slide bars. Figure 12 shows the relative positions of the cylinders and actuating locks before they are partially revolved. Figure 13 shows them after they have been partially revolved, and figure 14 shows them after they have completed their full travel. Figures 12, 13, and 14 show that 1^a releases 4^d and locks 3^c , and also that 4^d locks 2^b . Raising the catch rod of 1^a causes the toothed rack K , the slide bar H^1 , and the lock K^1 to travel in the direction of the arrow head, thus partially releasing and locking 4^d and 3^c respectively, as shown in figure 13. Figure 14 shows that the lever of 1^a has been pulled to the man, and the catch-rod dropped, thus completing the releasing and locking of 4^d and 3^c respectively, and that subsequently the lever of 4^d has been pulled and consequently locked 2^b . Figure 15 is a side elevation of one of the slotted cylinders, showing also sections of slide bars and locks whose side views are shown in figures 12, 13, and 14.

Figure 16 is a cross-section, and figure 17 is a side view, showing method of fixing actuating pinions to the slotted cylinders.

Figures 18, 19, 20, and 21 show the method of enabling two levers to release one lever, when such two levers lock one another, as in the case of two home signal levers, which lock each other, releasing one distant signal lever. Figure 18 is a cross-section through the slotted cylinders showing the actuating and ordinary locks in their normal positions. Figure 19 is the same cross-section when the lever of 7^c has been pulled to the man, thus releasing 5^a and locking 8^d by the lock K^1 . It is evident that if 8^d had been pulled instead of 7^c , 7^c would have been locked by the lock K^1 and 5^a released. Figure 20 is a plan of slide bars and connecting bars in their normal positions. Figure 21 is a cross-section of figure 20, showing method of attaching lever and rod for actuating the releasing lock.

Figures 22, 23, and 24, show the method of enabling a facing-point lever to stand normally locked by the facing-point lock lever, and to also be locked in its abnormal position by such facing-point lock lever. Figure 22 shows the positions of the slotted cylinders of the facing-point lock and facing-point levers when in their normal positions. Figure 23 shows them in their relative positions when the facing-point lock lever 10^a has been pulled to the man, and thus released; the facing-point lever 11^b and figure 24 shows them in their relative positions when the facing-point lever has been pulled to the man, and the facing-point lock lever has been pushed from the man, and thus locked the facing-point lever to the man.

In my drawings the parts marked A are the operating levers, which are bolted at their lower ends into the bell crank casting A^1 , which also carries the horizontal lever A^2 , and which crank pieces work side by side on the horizontal shaft A^3 supported in suitable bearings A^4 , as shown. B is the catch rod having the four projections B^1 thereon which cant the quadrant D . This catch rod is attached at its upper end to the hand lever A^2 , which is pivoted to the lever A . Its lower part passes through the slot A^5 , in said lever A , and at this extremity I affix the spiral springs B^2 whose lower ends are connected to the lever A , as shown. When the foot lever C , which is pivoted at C^1 to the lever A is used, the catch rod is attached to its backward extension C^2 , on whose end is the weight C^3 , as shown. D is the oscillating or canting quadrant of the form, shown more particularly in figures 4 and 5, and between the checks D^2 of which the lever A and catch rod B traverse. This quadrant has journals D^1 formed on both its ends which are made long enough to allow it to be inserted and securely fitted by pin, key, or otherwise into the hole provided in the one end of the slotted cylinders E . The quadrant is so constructed that slotted cylinders may be fixed at either or both ends of it. These journals D^1 work in the bearings formed in the bracket pieces F , as shown. The slotted cylinder E has slots formed in it for nearly its whole length on opposite sides, as shown, and in the necessary positions in their length the actuating locks J (figures 16 and 17) are placed, as shown in figure 15. These toothed actuating locks J are fixed into the slotted cylinders E by bolts or set screws, and they gear into the racks K (figure 15), which are bolted or riveted to the sliding bars G (figure 15) which are supported in the guide bars G^1 bolted to the flanges F . K , figure 15, are the racks, and K^1 , figure 12, are the ordinary locks, also bolted or riveted to the slide bars H^1 and H^2 at the desired positions for effecting the interlocking.

The mode of operation is as follows:—In working the points or signals, the connections to and from which are attached to the lever A^2 of the lever A , and supposing the lever A to be in its normal position as shown in full lines in figure 1, and that the lever A does not require to be released by the previous movement of any other lever or catch rod in the series, then the catch rod must be raised either by the hand or foot lever, and thus so partially revolve the quadrant that its slot is presented to the lever to travel through, and this raising of the catch rod and partial revolution of the quadrant also partially revolves the slotted cylinder which is attached to it, and makes the slide bar with which it is in gear perform half its travel, and thus locking other levers and half releasing others in the series then the passage of the lever A through the slot of the quadrant actuates the point or signal, as the case may be; then the lowering of the catch rod still further revolves the quadrant and blocks the lever in its abnormal position, and at the same time completes the partial revolution of the slotted cylinder and the travel of the slide bar, and thus completes the locking and the releasing of other levers in the series. Thus the action of even partially raising the catch rod securely locks other levers, but it is necessary to pull over the lever and completely lower the catch rod before other levers in the series are released. The raising and lowering of the catch rod B operates the interlocking. The moment the catch rod is raised or partially raised the solid portion of the slotted cylinders is presented to the ordinary locks, thus preventing their movement, and consequently preventing the raising of the catch rod (on any lever) by which they are operated, as shown by the slotted cylinder in figures 13 and 14.

Improvements in Interlocking Apparatus.

If, after the catch rod has been raised, it should be allowed to drop before the lever is pulled, the slotted cylinder will return to its normal position, as shown in figure 12, and if the catch rod has been raised and the lever pulled even ever so slightly through the slot in the quadrant, such catch rod cannot drop, nor can the quadrant be turned. When the catch rod is down or partially down at either end, the lever is effectually blocked by the quadrant, and when the catch is up and the lever pulled, the quadrant is effectually blocked by the lever. The locking is effectively done by the slightest preliminary movement of the catch rod, but the releasing is not finished until the lever has been travelled, and the subsequent lowering of the catch rod completed. The catch is prevented from being raised too high by the inner surface of the quadrant slamming against the lever.

The method thus described provides for the interlocking of levers in which it is only necessary to simply lock or release, but provision has also to be made for the well-known case of a facing point lock lever which may be required to lock a point lever both in its normal and abnormal positions. In this case the facing-point lock lever is first pulled from its normal to its abnormal position, thus releasing the point lever; the point lever is then pulled to its abnormal position, and then the facing-point lock lever is pushed back to its normal position and locks the point lever in its abnormal position. To enable this to be done, a slightly narrower lock is used in conjunction with the facing-point lock lever, and this arrangement is clearly shown in figures 22, 23, and 24.

In the case of two levers (say X and Y) releasing one lever (say Z), when such two levers lock one another, the method of operation is as follows:—A connecting rod or lever is attached to both slide bars of the two levers X and Y, and in the centre of such connecting rod is attached a bar on which is a releasing lock, which releases Z. The connecting rod or lever is so arranged that if X should be first pulled it will lock Y and release Z, but if Y should be first pulled it will lock X and release Z. If the slide bar of X is travelled it will work the connecting rod or lever with the slide bar of Y as a fulcrum and release Z, but if the slide bar of Y is first travelled it will work the connecting rod with the slide bar of X as a fulcrum and release Z.

Having now described the nature of my invention and the manner of performing the same, I would have it understood that what I believe to be new, and therefore claim as my improvements in interlocking apparatus, are—

- First—The construction of the catchrod with four projections, as shown, for giving motion to the oscillating quadrant, and the construction of the quadrant, as shown, to enable such motion to be given by such projections.
- Second—The placing of the lower part of the catch rod in the slotted hole in the radial centre line of the operating lever, so that the centre line of the catch rod is radial with the pivot of the lever, thus obtaining a direct radial action of the catch rod.
- Third—The combination of the oscillating quadrant and slotted cylinder practically in one piece, and thus obtaining direct action by the catch rod on the slotted cylinder without the intervention of any cranks or other mechanism.
- Fourth—The combination of the suitably-shaped slotted cylinder E with the actuating segmental gearing J and rack K for operating the ordinary locks as described.
- Fifth—The construction of the slide bars of two thin bars with the locks and slide bar guides between them, as shown, and the construction of the locks, slide bar guides, and combined locks and slide bar guides and their combination, with the slotted cylinders, and also with the racks which support the slide bars.
- Sixth—The use of a pedal lever, in the manner shown, for working or assisting to work the catch rod in such apparatus.
- Seventh—The combination of the lever, catch rod, oscillating quadrant, and cylinder with their respective attachments, in the manner and for the purposes herein described and explained.

In witness whereof, we, the said Robert Archibald White, Arthur Lucas Harrold, and Walter Frampton, have hereto set our hands and seals, this third day of September, one thousand eight hundred and eighty four.

Witness—

CHARLES M. MUIRHEAD,
Solicitor, &c., Adelaide.

ROBT. A. WHITE.
ARTHUR LUCAS HARROLD.
WALTER FRAMPTON.

This is the specification referred to in the annexed Letters of Registration granted to Robert Archibald White, Arthur Lucas Harrold, and Walter Frampton, the 23rd day of October, A.D. 1884.

AUGUSTUS LOFTUS.

REPORT.

Sir,

In reply to your B.C. of the 16th instant, forwarding a Petition for Letters of Registration for an invention entitled "Improvements in Interlocking Apparatus," we have the honor, after having examined the drawing and specification accompanying the Petition, to recommend that its prayer be acceded to.

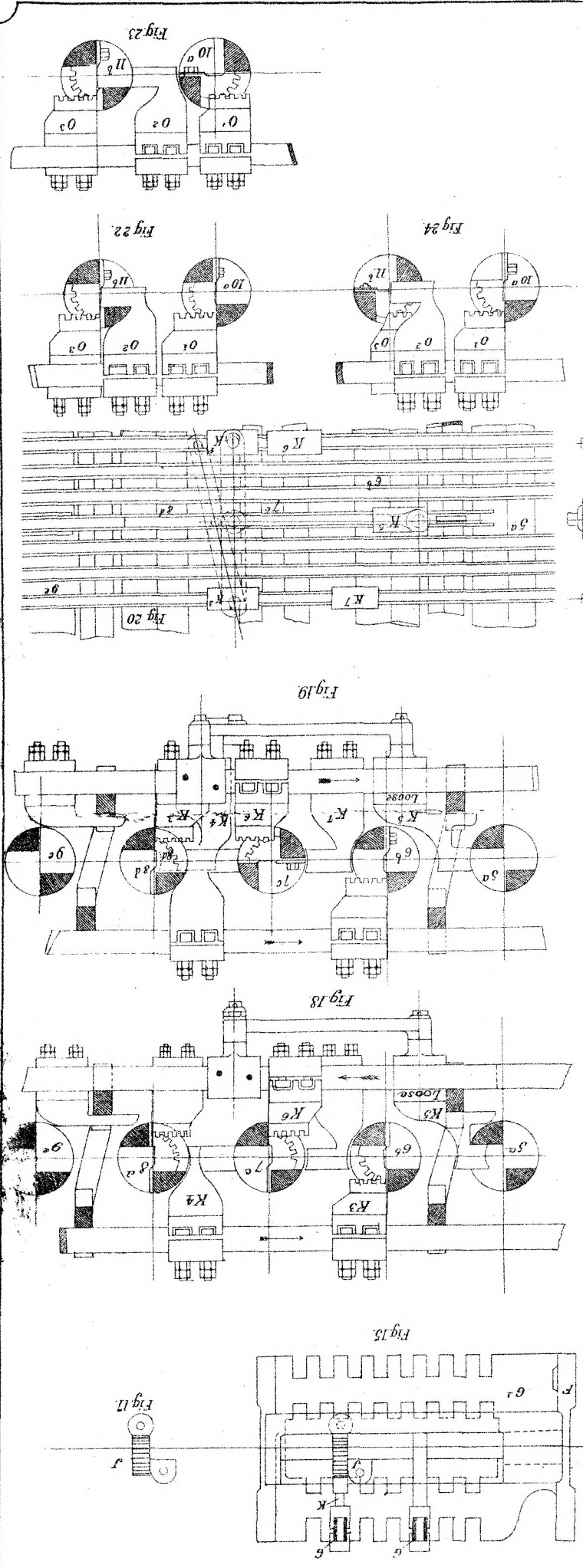
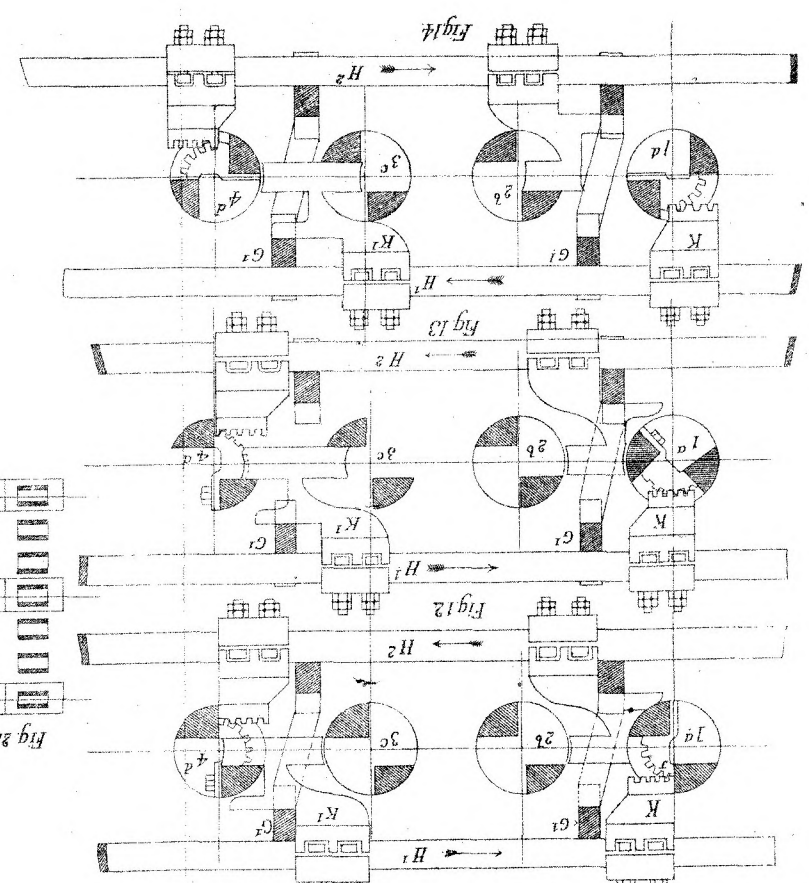
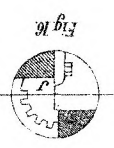
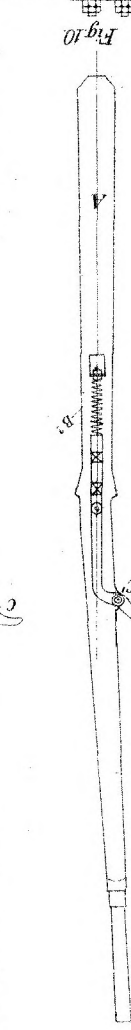
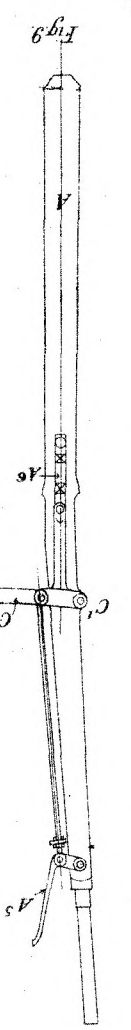
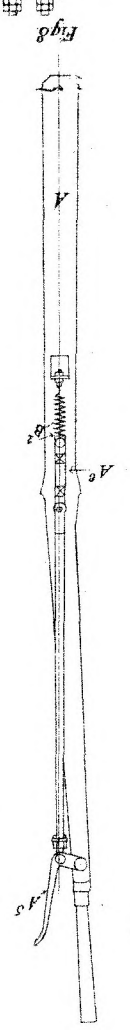
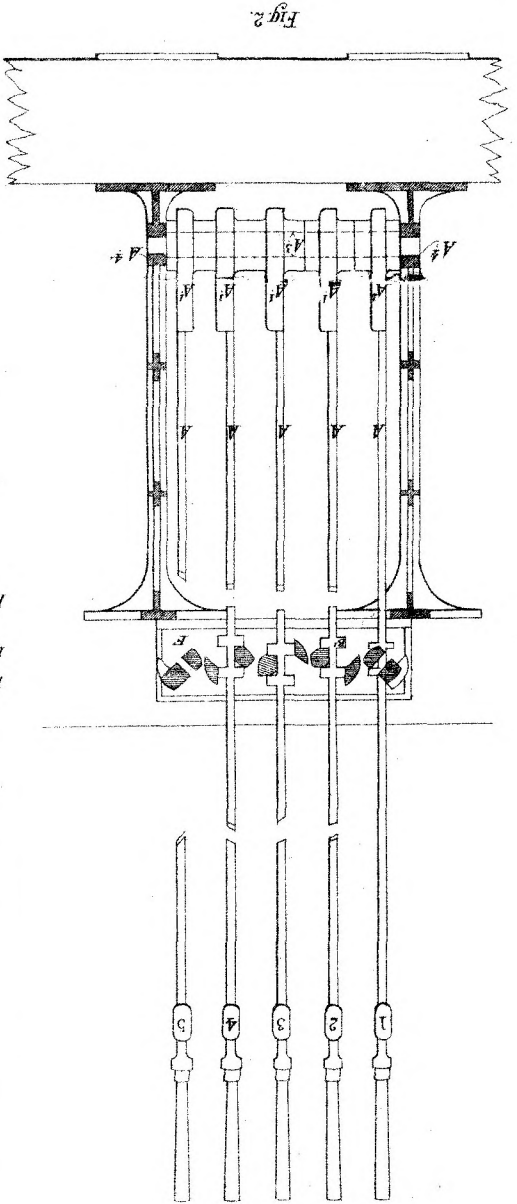
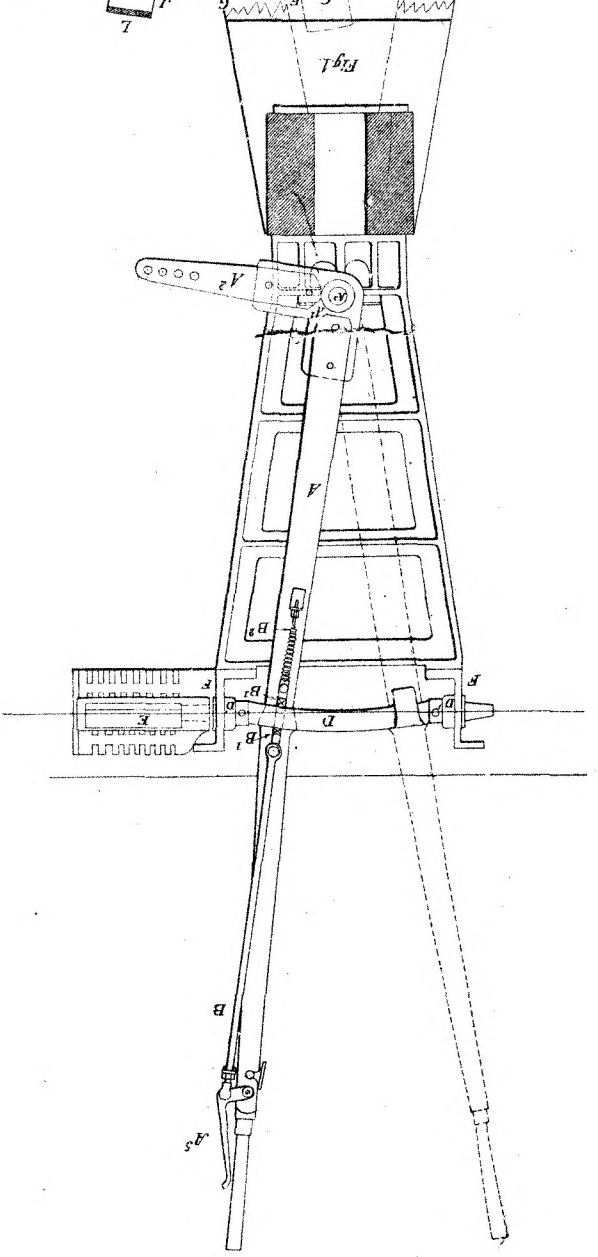
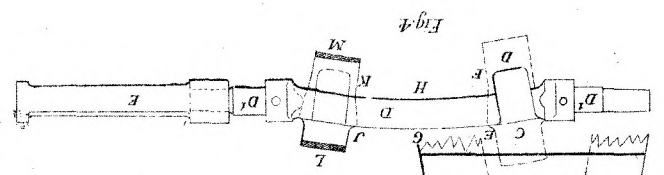
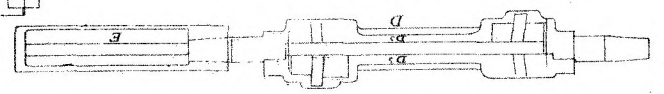
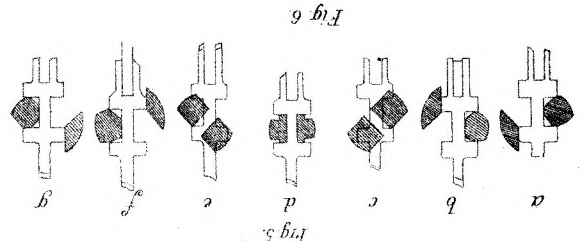
Sydney, 20 September, 1884.

We have, &c.,

JOHN WHITTON,
E. O. MORIARTY.

The Under Secretary of Justice.

This is the Sheet of Drawings referred to in the annexed Letters of Request given to Robert Arthur White, Arthur Lucas Harwood, and Walter Thompson, the Inventors of the Improved Letter-press of Augustus Loftus.





A.D. 1884, 15th November. No. 1529.

IMPROVED COATING FOR EXPLOSIVE COMPOUNDS AND CARTRIDGES.

LETTERS OF REGISTRATION to Michael Cock, for an Improved Coating for Explosive Compounds and Cartridges.

[Registered on the 15th day of November, 1884, in pursuance of the Act 16 Vic. No. 24.]

BY HIS EXCELLENCY THE RIGHT HONORABLE SIR AUGUSTUS WILLIAM FREDERICK SPENCER LOFTUS (commonly called LORD AUGUSTUS LOFTUS), Knight Grand Cross of the Most Honorable Order of the Bath, a Member of Her Majesty's Most Honorable Privy Council, Governor and Commander-in-Chief of the Colony of New South Wales and its Dependencies.

TO ALL TO WHOM THESE PRESENTS SHALL COME, greeting:

WHEREAS MICHAEL COCK, of Golden Square, Sandhurst, in the Colony of Victoria, mining engineer, hath by his Petition humbly represented to me that he is the author or designer of a certain invention or improvement in manufactures, that is to say, of an invention entitled "An Improved Coating for Explosive Compounds and Cartridges," which is more particularly described in the specification which is hereunto annexed; and that he, the said Petitioner, hath deposited with the Honorable the Treasurer of the said Colony of New South Wales the sum of Twenty Pounds sterling, for defraying the expense of granting these Letters of Registration, as required by the Act of Council, sixteenth Victoria, number twenty-four; and hath humbly prayed that I would be pleased to grant Letters of Registration, whereby the exclusive enjoyment and advantage of the said invention or improvement might be secured to him for a period of fourteen years: And I, being willing to give encouragement to all inventions and improvements in the arts or manufactures which may be for the public good, and having received a report favourable to the prayer of the said Petition, from competent persons appointed by me to examine and consider the matters stated therein and to report thereon for my information, am pleased, with the advice of the Executive Council, and in exercise of the power and authority given to me by the said Act of Council, to grant, and do by these Letters of Registration grant unto the said Michael Cock, his executors, administrators, and assigns, the exclusive enjoyment and advantage of the said invention or improvement, for and during the term of fourteen years from the date hereof; to have, hold, and exercise unto the said Michael Cock, his executors, administrators, and assigns, the exclusive enjoyment and advantage thereof, for and during and unto the full end and term of fourteen years from the date of these presents next and immediately ensuing, and fully to be complete and ended: Provided always, that if the said Michael Cock, shall not, within three days after the granting of these Letters of Registration, register the same in the proper office in the Supreme Court, at Sydney, in the said Colony of New South Wales, then these Letters of Registration, and all advantages whatsoever hereby granted, shall cease and become void.

In witness whereof, I have hereunto set my sign manual, and have caused the present Letters of Registration to be sealed with the seal of the said Colony of New South Wales, at Government House, Sydney, in New South Wales, this fifteenth day of November, in the year of our Lord one thousand eight hundred and eighty-four.

[L.S.]

AUGUSTUS LOFTUS.

An Improved Coating for Explosive Compounds and Cartridges.

SPECIFICATION of MICHAEL COCK, of Golden Square, Sandhurst, in the Colony of Victoria, mining manager, for an invention entitled "An Improved Coating for Explosive Compounds and Cartridges."

THIS invention has been designed principally for the purpose of providing cartridges with a waterproof coating which will not injuriously affect the ingredients of which such cartridges are composed, but rather assist them. This coating, however, is not only beneficial for its waterproof properties, but for the prevention or lessening of abrasion in use and transport; and, if preferred, it may be used simply for this purpose, or as a lining for other coatings. It is applicable to cartridges of all kinds, nitro-glycerine ones included, and to explosive compounds of all kinds; but it is not intended for use as a coating for the grains of finely powdered explosives, but only for those of coarser grain, such as are commonly known as pellet powders, although it may be used for explosives of finest powder if desired.

My coating consists of melted sulphur, or melted compounds or mixtures of sulphur, such, for instance, as black lead and sulphur, or iron and sulphur; but these mixtures and compounds can be multiplied almost indefinitely. My novelty consists in the sulphur, either alone or compounded, or mixed with any other ingredients, or forming part of any other natural product.

The cartridges or explosive compounds to be coated are simply warmed and then dipped into the melted sulphur or compounds or mixtures of sulphur, and then allowed to dry. The coating they are allowed to take up, may be of any desired thickness, and when dry may be painted, or varnished, or covered with another and outer coating.

One great advantage obtained by the use of my invention is that nitrate of soda can be substituted with safety for nitrate of potash in all explosives and cartridges, in which, said latter ingredient is now commonly used, and so greatly reduce their cost; and inasmuch as it will prevent the exudation of oil from cartridges made of dynamite or other nitro-glycerine compounds, it greatly lessens the danger arising from the use of such materials. It will thus be seen that by my invention, cheaper and safer cartridges can be made than by any other process, while grains of pellet and other powders can be made cheaper and rendered quite waterproof.

Having thus described the nature of my invention, and the manner of performing same, I would have it understood that I do not confine the application of my invention to any particular kind of explosive compound or cartridge, nor to the use of pure sulphur or of any particular mixture or compound of sulphur; but what I believe to be new, and therefore claim as my invention, is:—

The coating of cartridges and of explosive compounds with melted sulphur, or melted compounds, or mixtures of sulphur, substantially as and for the purposes herein described and explained.

In witness whereof, I, the said Michael Cock, have hereto set my hand and seal, this sixteenth day of September, one thousand eight hundred and eighty-four.

MICHAEL COCK.

Witness—

EDWD. WATERS, Melbourne,
Patent Agent.

This is the specification referred to in the annexed Letters of Registration granted to Michael Cock, the fifteenth day of November, A.D. 1884.

AUGUSTUS LOFTUS.

REPORT.

Sir,

In reply to your blank cover, 24th instant, transmitting Mr. Michael Cock's Petition for the registration of an invention, entitled "An Improved Coating for Explosive Compounds and Cartridges," we do ourselves the honor to report that we are of opinion the prayer of the Petitioner may be granted, in terms of his specification and claim.

Sydney, 29 September, 1884.

We have, &c.,

E. C. CRACKNELL.
GOTHER K. MANN.

The Under Secretary of Justice.



A.D. 1884, 15th November. No. 1530.

AN IMPROVED TIP BALLAST-WAGGON.

LETTERS OF REGISTRATION to William Thompson and Mary Ann Edwards,
for an Improved Tip Ballast-waggon.

[Registered on the 15th day of November, 1884, in pursuance of the Act 16 Vic. No. 24.]

BY HIS EXCELLENCY THE RIGHT HONORABLE SIR AUGUSTUS WILLIAM FREDERICK SPENCER LOFTUS
(commonly called LORD AUGUSTUS LOFTUS), Knight Grand Cross of the Most Honorable Order of the
Bath, a Member of Her Majesty's Most Honorable Privy Council, Governor and Commander-in-Chief
of the Colony of New South Wales and its Dependencies.

TO ALL TO WHOM THESE PRESENTS SHALL COME, greeting :

WHEREAS WILLIAM THOMPSON, of Commercial Road, Prahran, in the Colony of Victoria, gunsmitth, and Mary Ann Edwards, of Commercial Road aforesaid, have by their Petition humbly represented to me that the Petitioner, William Thompson, is the author or designer of a certain invention or improvement in manufactures, that is to say, of an invention entitled "An Improved Tip Ballast-waggon," which is more particularly described in the specification and the sheet of drawings which are hereunto annexed; and that the Petitioner, Mary Ann Edwards, is the assignee of one-half part or share of and in the said invention so far as the Colony of New South Wales is concerned; and that they, the said Petitioners, have deposited with the Honorable the Treasurer of the said Colony of New South Wales the sum of Twenty Pounds sterling, for defraying the expense of granting these Letters of Registration, as required by the Act of Council, sixteenth Victoria, number twenty-four; and have humbly prayed that I would be pleased to grant Letters of Registration, whereby the exclusive enjoyment and advantage of the said invention or improvement might be secured to them for a period of fourteen years: And I, being willing to give encouragement to all inventions and improvements in the arts or manufactures which may be for the public good, and having received a report favourable to the prayer of the said Petition from competent persons appointed by me to examine and consider the matters stated therein and to report thereon for my information, am pleased, with the advice of the Executive Council, and in exercise of the power and authority given to me by the said Act of Council, to grant, and do by these Letters of Registration grant unto the said William Thompson and Mary Ann Edwards, their executors, administrators, and assignis, the exclusive enjoyment and advantage of the said invention or improvement, for and during the term of fourteen years from the date hereof; to have, hold, and exercise unto the said William Thompson and Mary Ann Edwards, their executors, administrators, and assignis, the exclusive enjoyment and advantage thereof, for and during and unto the full end and term of fourteen years from the date of these presents next and immediately ensuing, and fully to be complete and ended: Provided always, that if the said William Thompson and Mary Ann Edwards shall not, within three days after the granting of these Letters of Registration, register the same in the proper office in the Supreme Court, at Sydney, in the said Colony of New South Wales, then these Letters of Registration, and all advantages whatsoever hereby granted, shall cease and become void.

In witness whereof, I have hereunto set my sign manual, and have caused the present Letters of Registration to be sealed with the seal of the said Colony of New South Wales, at Government House, Sydney, in New South Wales, this fifteenth day of November, in the year of our Lord one thousand eight hundred and eighty-four.

[L.S.]

AUGUSTUS LOFTUS.

An Improved Tip Ballast-waggon.

SPECIFICATION of WILLIAM THOMPSON, of Commercial Road, Prahran, in the Colony of Victoria, gunsmith, and MARY ANN EDWARDS, of Commercial Road aforesaid, the said Mary Ann Edwards being the assignee of one-half part or share of and in an invention invented by the said William Thompson, and entitled "An Improved Tip Ballast-waggon."

THIS invention consists of an improved tip ballast-waggon, which is capable of discharging on either side and at any angle within the limits of its construction.

The under-frame is somewhat similar to that of an ordinary ballast-waggon, and to this we attach several series of friction rollers set in the direction of the travel of the body when it is tipping. This is to let the body run and move easily. For giving the necessary side motion to the body when it is being tipped, we provide one or more winding drums, to each of which we attach one end of two chains, which we wind on the drum in opposite directions, so that when one is winding the other is unwinding. Each of these chains we pass around a pulley or roller at one side of the waggon frame and lead it to a shackle or fastening near the opposite side of the bottom of the tip-body. These drums are all on one spindle, which receives motion through the intervention of bevel and spur gearing from a cross spindle worked by a removable handle. To assist in the travel, and also to preserve the body of the waggon from being disconnected from the framing, we provide a series of friction rollers attached to the bottom of the tip-body and working in guides formed on the top of the framing. The angle at which the body is to tip is determined by the angle and position of the end angle-iron brackets, and also by the size and shape of projecting pieces on each side of the under-framing. The sides of the body are suspended on hinges at the top, and when in the act of tipping they open automatically by means of certain catches being released from holding the bottom of them so as to allow them to swing open. When being returned to position these catches automatically fasten themselves. Under one end of the body we provide a draw-bolt, which has to be released before it can be tipped, and which, when not held down, automatically refastens itself before the body can be retipped, so that it has to be released for this purpose at each tipping operation.

Referring to our drawings—Fig. 1 shows a plan of our waggon with the body tipped; fig. 2 sectional elevation of same on the line *a a* in fig. 1; fig. 3 longitudinal section and elevation looking from line *b b* in fig. 1; fig. 4 cross-section of the under-carriage with locking-gear and door-catch; fig. 5 side view of the locking-gear; and fig. 6 plan of the door catch. *A* is the under-carriage, supported on wheels *A*¹, and *B* is the body which tips. The sides of this body are suspended by arms *B*¹, terminating in an eye which pivots on studs or pins *B*², supported on standards *B*³, bolted to the end of the body. These standards are stayed by rods *B*⁴ bolted to the bottom of the body at *B*⁵. *B*⁶ *B*⁶ are catches which keep the sides closed until they are released in the act of tipping, those on one side being quite unconnected with those on the other side, but constructed identically alike. These catches are each centered on a pin *B*⁷, which has its bearings in the bracket *B*⁸, fastened to the under-side of the bottom of the body. Furthermore, these catches have slots on one side at *B*⁹, into which there fit spring pins *B*¹⁰. These catches are opened and closed by projections *A*² on the under-framing, which projections also regulate the angle at which the body is allowed to tip. *B*¹¹ *B*¹¹ are simply iron face plates on wooden stay beams, passing transversely across the under-side of the bottom of the body and forming a smooth surface for travelling over the friction rollers *A*³, supported in bearings in the under-carriage. *B*¹² *B*¹² are friction rollers supported by brackets *B*¹³ projecting from iron plates *B*¹⁴ securely fastened to the under-side of the bottom of the body. These rollers *B*¹² travel between guides *A*⁴ securely bolted to the under-carriage. *B*¹⁵ *B*¹⁵ are the anchorages on either side of the bottom of the body for chains *C* and *E*. *A*⁵ *A*⁵ are friction rollers, supported on one side of the under-carriage, and *A*⁶ *A*⁶ friction rollers, supported on the other side of the under-carriage by brackets *A*⁷ and *A*⁸, which form fulcra for such chains to work on. Chains *C* pass around friction rollers *A*⁵ to the winding drums *A*⁹, and chains *E* passing over friction rollers *A*⁶ and around friction rollers *A*⁶, also the winding drums *A*⁹. These winding drums are both on one shaft *A*¹⁰, on one end of which is bevel wheel *A*¹¹, driven by bevel pinion *A*¹² on shaft *A*¹³, on which also is toothed wheel *A*¹⁴ driven by spur pinion *A*¹⁵ on spindle *A*¹⁶, which is worked from either end, as required, by a removable handle or key *A*¹⁷. *D* is a vertical bolt or catch which slides up and down in a case *D*¹, and is kept up by a weight *D*², supported on a lever attached to the heel of the bolt. This lever is connected by a link or rod *D*³ to a second rod *D*⁴, which is rigidly connected to a cross spindle *D*⁵ resting in bearings *D*⁶ on the under-carriage. On each end of this spindle are levers *D*⁷ connecting said spindle to rods *D*⁸, each of which is connected to the inner end of another lever *D*⁹, pivoted at *D*¹⁰, and having a handle *D*¹¹ for withdrawing said bolt *D* when the body is required to be tipped. *D*¹² *D*¹² are two retaining catches, one on either side, for preserving the bolt *D* in its disconnected position after it has been thrown out of gear by one of the handles *D*¹¹. *D*¹³ is an iron plate, cranked in the centre, to form the recess *D*¹⁴ for the reception of the bolt *D* when it is in gear. *F* *F* are the end plates secured to the under-carriage, and to these are bolted the angular stay brackets *F*¹, which assist and prevent the over-tipping of the body, by the ends of its bottom resting against the flanges *F*² of said stay bracket.

In operation our waggon works as follows:—When about to be filled the body lies horizontally on its under-carriage, the catches *B*⁶ are fast, holding the sides firmly in position, and the bolt *D* is in the recess *D*¹⁴, the friction rollers *B*¹² being in the centre of their guides. When required to be tipped, the first thing to be done is to release the bolt *D*. This is done by simply moving the handle *D*¹¹. Then the handle or key *A*¹⁷ is placed on that end of the spindle *A*¹⁶ which is on the opposite side to the direction in which the body is to tip, and by winding which handle in the required direction the winding drum will revolve, winding up the chains and compelling the body to travel sideways, as required. Just as the body is tipped, the projections *A*² press against the tail of the catches *B*⁶ and open them, when the side immediately swings open, allowing the contents of the waggon to be slid out. When this is done the handle *A*¹⁷ must be re-wound in the opposite direction, when the body will resume its original position, and the projections *A*² will again come into play by pressing the heads of the catches into their original position, thus securely closing the sides. The bolt *D* must then be released, when it will spring into place and so lock the body and its under-carriage as before.

Having

An Improved Tip Ballast-waggon.

Having thus described the nature of our invention, and the manner of performing same, we would have it understood that what we believe to be new in our improved tip ballast-waggon, and therefore claim as of our invention, is—

First—The combination of the parts for giving the necessary side travel to the body, consisting of the cranked handle A¹, spindle A¹⁶, spur-wheel and pinion A¹³ and A¹⁴, shaft A¹³, bevel wheel and pinion A¹¹ and A¹², shaft A¹⁰, drums A⁹, chains C and E, rollers A⁵ and A⁶, brackets A⁷ and A⁸, fitted to the under-carriage, with the body having the fixings B¹⁰ thereon for securing the chains C and E, substantially as herein described and explained.

Second—The combination of the parts marked B⁵, B⁷, B⁸, B⁹, and B¹⁰ attached to the body, and forming the catches for its sides with their projections A² attached to the under-carriage, substantially as herein described and as illustrated in figs. 4 and 6 of our drawings.

Third—The combination of the parts marked from D to D¹³ attached to the under-carriage, with the plate D¹³ having recess D¹¹, and secured to the bottom of body and forming the lock for locking the body to the under-carriage, substantially as herein described and as illustrated in figs. 1, 3, 4, and 5 of our drawings.

Fourth—The combination and arrangement of the body secured to the guides A⁴ on its under-frame by the parts marked B¹², B¹³, B¹¹, with the friction rollers A³, and the parts marked F F¹ and F² forming the stay brackets, substantially as herein described and as illustrated in our drawings.

In witness whereof, we, the said William Thompson and Mary Ann Edwards, have hereto set our hands and seals, this twenty-seventh day of September, one thousand eight hundred and eighty-four.

Witness—

EDWARD WATERS,
Melbourne, Patent Agent.

WILLIAM THOMPSON.
M. A. EDWARDS.

This is the specification referred to in the annexed Letters of Registration granted to William Thompson and Mary Ann Edwards, the fifteenth day of November, A.D. 1884.

AUGUSTUS LOFTUS.

REPORT.

Sir,

In reply to your B.C. minute of the 2nd instant, forwarding plans and specification for an invention entitled "An Improved Tip Ballast-waggon," for which Letters of Registration are asked by W. Thompson and Mary Ann Edwards, we have the honor to report that we know of no reason why protection should not be granted.

The Under Secretary of Justice.

Sydney, 7 October, 1884.

We have, &c.,

JAMES BARNET.
WILLIAM C. BENNETT.

[Drawings—one sheet.]

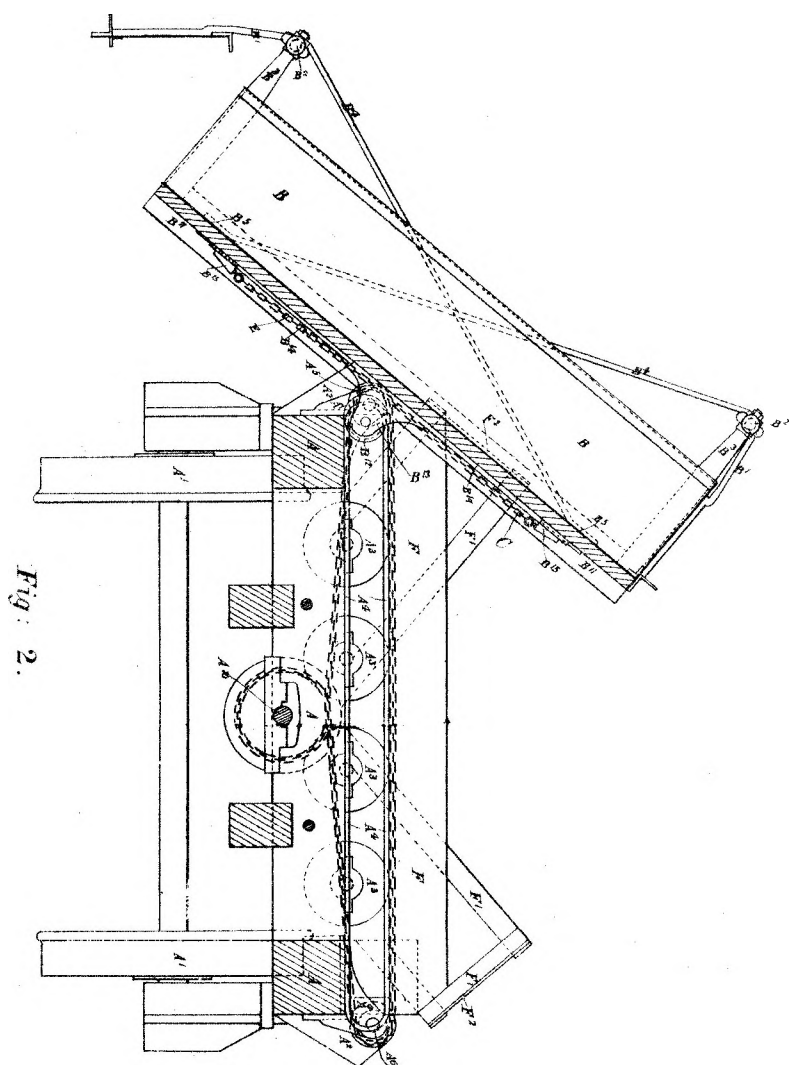


Fig. 2.

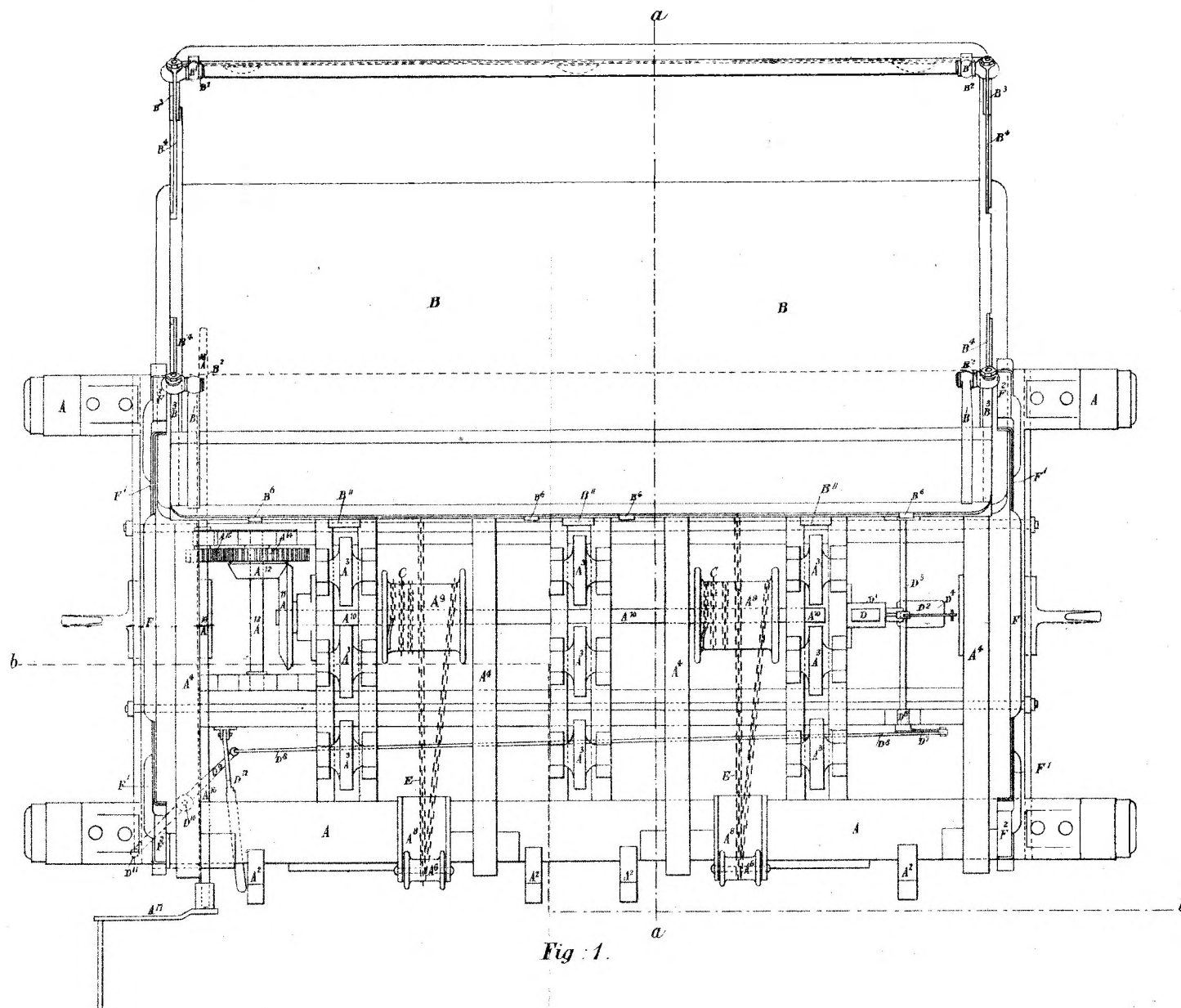


Fig. 1.

WILLIAM THOMPSON'S PATENT.

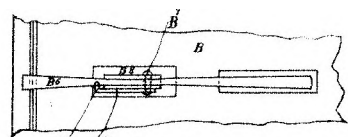


Fig. 6.

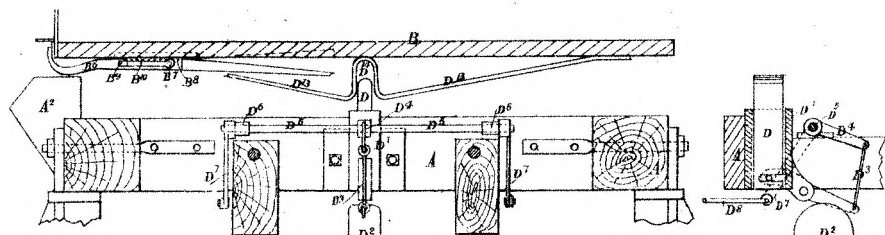


Fig. 4.

Fig. 5.

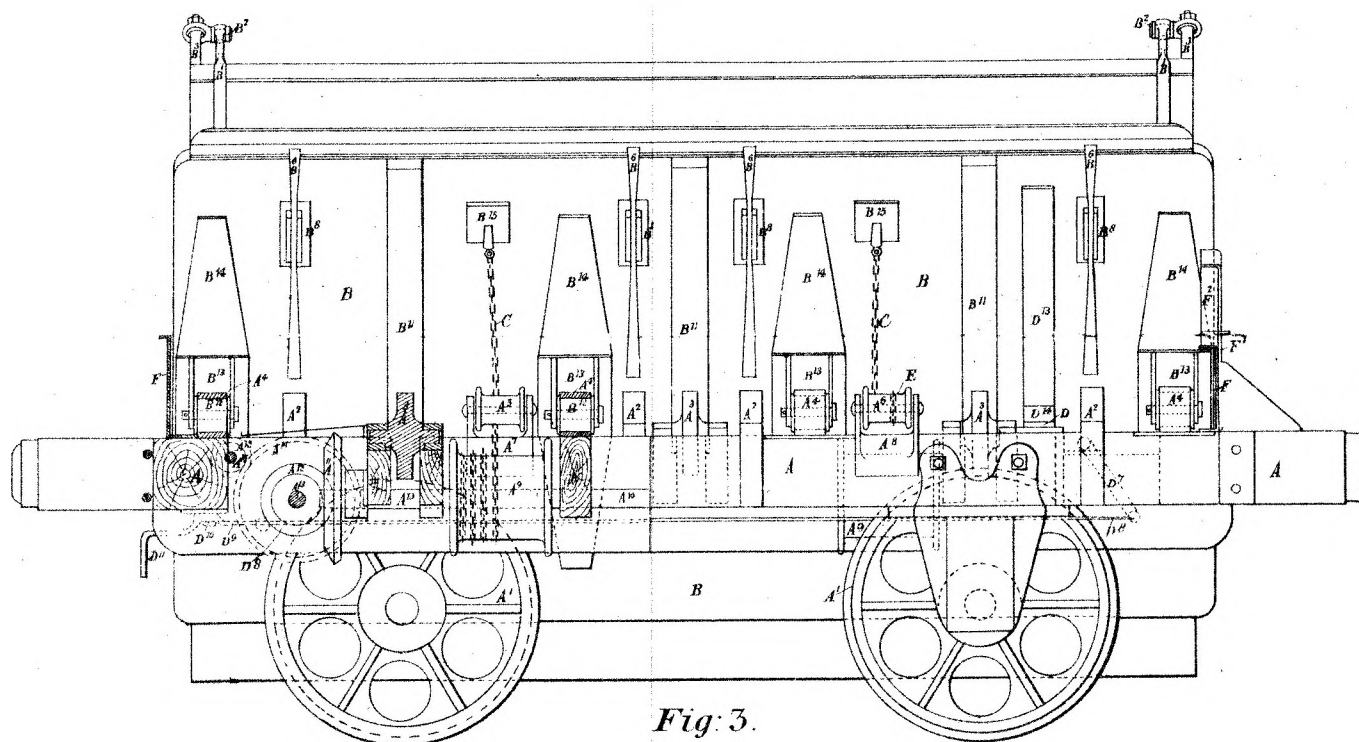


Fig. 3.

This is the Sheet of Drawings referred to in the annexed Letters of Registration, granted to William Thompson, and Mary Ann Edwards, the fifteenth day of November: A. D., 1884.
Augustus Loftus.

(Sig. 245~)



A.D. 1884, 15th November. No. 1531.

IMPROVEMENTS IN BLAST SMELTING FURNACES.

LETTERS OF REGISTRATION to Thomas Gillespie, for Improvements in Blast Smelting Furnaces.

[Registered on the 15th day of November, 1884, in pursuance of the Act 16 Vic. No. 24.]

BY HIS EXCELLENCY THE RIGHT HONORABLE SIR AUGUSTUS WILLIAM FREDERICK SPENCER LOFTUS (commonly called LORD AUGUSTUS LOFTUS), Knight Grand Cross of the Most Honorable Order of the Bath, a Member of Her Majesty's Most Honorable Privy Council, Governor and Commander-in-Chief of the Colony of New South Wales and its Dependencies.

TO ALL TO WHOM THESE PRESENTS SHALL COME, greeting :

WHEREAS THOMAS GILLESPIE, of Sydney, in the Colony of New South Wales, gentleman, hath by his Petition humbly represented to me that he is the author or designer of a certain invention or improvement in manufactures, that is to say, of an invention entitled "An Improvement in Blast Smelting Furnaces," which is more particularly described in the specification which is hereunto annexed; and that he, the said Petitioner, hath deposited with the Honorable the Treasurer of the said Colony of New South Wales the sum of Twenty Pounds sterling, for defraying the expense of granting these Letters of Registration, as required by the Act of Council, sixteenth Victoria, number twenty-four; and hath humbly prayed that I would be pleased to grant Letters of Registration, whereby the exclusive enjoyment and advantage of the said invention or improvement might be secured to him for a period of fourteen years; And I, being willing to give encouragement to all inventions and improvements in the arts or manufactures which may be for the public good, and having received a report favourable to the prayer of the said Petition from competent persons appointed by me to examine and consider the matters stated therein and to report thereon for my information, am pleased, with the advice of the Executive Council, and in exercise of the power and authority given to me by the said Act of Council, to grant, and do by these Letters of Registration grant unto the said Thomas Gillespie, his executors, administrators, and assigns, the exclusive enjoyment and advantage of the said invention or improvement, for and during the term of fourteen years from the date hereof; to have, hold, and exercise unto the said Thomas Gillespie, his executors, administrators, and assigns, the exclusive enjoyment and advantage thereof, for and during and unto the full end and term of fourteen years from the date of these presents next and immediately ensuing, and fully to be complete and ended: Provided always, that if the said Thomas Gillespie shall not, within three days after the granting of these Letters of Registration, register the same in the proper office in the Supreme Court, at Sydney, in the said Colony of New South Wales, then these Letters of Registration, and all advantages whatsoever hereby granted, shall cease and become void.

In witness whereof, I have hereunto set my sign manual, and have caused the present Letters of Registration to be sealed with the seal of the said Colony of New South Wales, at Government House, Sydney, in New South Wales, this fifteenth day of November, in the year of our Lord one thousand eight hundred and eighty-four.

[L.S.]

AUGUSTUS LOFTUS.

Improvements in Blast Smelting Furnaces.

SPECIFICATION of THOMAS GILLESPIE, of Sydney, in the Colony of New South Wales, gentleman, for an invention entitled "An Improvement in Blast Smelting Furnaces."

THIS invention has been designed for the purpose of preventing the lower end of blast smelting furnaces becoming choked or clogged by the accumulated slag arising from the smelting of successive charges of ore. At present this is a very serious difficulty, as it is no uncommon thing for a furnace to become entirely choked or "frozen," as it is sometimes called, in the course of a few weeks, necessitating an entire stoppage of work, and considerable trouble and expense in removing such slag, and recommencing operations. Now, I not only prevent the injury to the furnace which arises from this process of "freezing," but I enable it to work continuously (until it requires repair from other causes), thus effecting a great saving and affording a great convenience at one and the same time. My invention consists simply in adding a close chamber at or near, and at a lower level than the bottom of the furnace, and in providing a passage or tap-hole from said furnace into said chamber, so that as the ore melts it runs gradually through the tap-hole into the chamber without depositing any slag in the furnace. With the melted ore there also enters through the tap-hole a stream of flame, which, playing upon the surface of the material in said chamber, preserves it in a state of fusion. In one of the walls of said chamber, I provide two other tap-holes, the upper one being near the top, and the lower one on a level with the bottom. The lower one is closed until the charge is ready to be drawn off, but the upper one is kept open so as to allow of the escape of the slag until the chamber becomes so full that regulus instead of slag shows itself at the upper hole, then it is closed, and the lower one opened to allow of the escape of the regulus, which runs into suitable vessels provided to receive it. When this has all run out the lower hole is closed, and the upper one opened as before, the operations of the furnace being thus continuous and without interruption, except so far as is necessary to provide for the ordinary wear and tear. In order to enable the workman to close this upper hole it is necessary to make a temporary vent in the upper part of such chamber so as to direct the current of flame away from said upper hole. This vent may be made by simply removing a brick from the roof or top of the chamber, and placing thereon a short length of tubing for a flue.

I do not confine myself to any particular shape or size of my additional chamber, nor to any particular kind of blast smelting furnace to which it may be attached; but I prefer to make such chambers oblong in shape, and I think it is desirable that one or more of the tuyeres should be directed towards the tap-hole in the furnace which leads to my said chamber.

Having thus described the nature of my said invention, and the manner of performing same, I would have it understood that what I believe to be new, and therefore claim as of my invention, is—

The combination with blast smelting furnaces of an additional or subsidiary closed chamber for the reception of the fused ore from said furnace through a suitable passage so as to prevent the accumulation of slag in the furnace, and to admit of the separation of the regulus from the slag in said chamber, substantially as herein described and explained.

In witness whereof, I, the said Thomas Gillespie, have hereto set my hand and seal, this fifteenth day of September, one thousand eight hundred and eighty-four.

THOMAS GILLESPIE.

Witness—

FRED. WALSH,
Manager, Edwd. Waters' Patent Office, Sydney.

This is the specification referred to in the annexed Letters of Registration granted to Thomas Gillespie, the fifteenth day of November, A.D. 1884.

AUGUSTUS LOFTUS.

REPORT.

Sir,

Sydney, 24 September, 1884.

The application of Mr. Thomas Gillespie for Letters of Registration for "An Improvement in Blast Furnaces" having been referred to us, we have examined the specification accompanying the same, and have now the honor to report that we see no objection to the issue of Letters of Registration as prayed for.

We have, &c.,

J. SMITH.

A. LEIBIUS.

The Under Secretary of Justice.



A.D. 1884, 18th November. No. 1532.

IMPROVEMENTS IN CRADLES FOR RECEIVING AND DELIVERING CUT CROP
FROM HARVESTING MACHINES.

LETTERS OF REGISTRATION to James Hornsby, Frederick Charles Southwell,
and John Innocent, for Improvements in Cradles for receiving and delivering
cut crop from Harvesting Machines.

[Registered on the 18th day of November, 1884, in pursuance of the Act 16 Vic. No. 24.]

BY HIS EXCELLENCY THE RIGHT HONORABLE SIR AUGUSTUS WILLIAM FREDERICK SPENCER LOFTUS
(commonly called LORD AUGUSTUS LOFTUS), Knight Grand Cross of the Most Honorable Order of
the Bath, a Member of Her Majesty's Most Honorable Privy Council, Governor and Commander-in-
Chief of the Colony of New South Wales and its Dependencies.

TO ALL TO WHOM THESE PRESENTS SHALL COME, greeting :

WHEREAS JAMES HORNSBY, FREDERICK CHARLES SOUTHWELL, and JOHN INNOCENT, all of the
Spittlegate Iron Works, Grantham, in the county of Lincoln, England, engineers, have by their Petition
humbly represented to me that they are the authors or designers of a certain invention or improvement in
manufactures, that is to say, of an invention entitled "Improvements in Cradles for receiving and delivering
cut crop from Harvesting Machines," which is more particularly described in the specification, marked
A, and the three sheets of drawings, marked B, C, and D, respectively, which are hereunto
annexed; and that they, the said Petitioners, have deposited with the Honorable the Treasurer of
the said Colony of New South Wales the sum of Twenty Pounds sterling, for defraying the expense
of granting these Letters of Registration, as required by the Act of Council, sixteenth Victoria, number
twenty-four; and have humbly prayed that I would be pleased to grant Letters of Registration, whereby
the exclusive enjoyment and advantage of the said invention or improvement might be secured to
them for a period of fourteen years: And I, being willing to give encouragement to all inventions and
improvements in the arts or manufactures which may be for the public good, and having received a report
favourable to the prayer of the said Petition, from competent persons appointed by me to examine and
consider the matters stated therein and to report thereon for my information, am pleased, with the advice of
the Executive Council, and in exercise of the power and authority given to me by the said Act of Council,
to grant, and do by these Letters of Registration grant unto the said James Hornsby, Frederick Charles
Southwell, and John Innocent, their executors, administrators, and assigns, the exclusive enjoyment and
advantage of the said invention or improvement, for and during the term of fourteen years from the date
hereof; to have, hold, and exercise unto the said James Hornsby, Frederick Charles Southwell, and John
Innocent, their executors, administrators, and assigns, the exclusive enjoyment and advantage thereof, for
and during and unto the full end and term of fourteen years from the date of these presents next and
immediately ensuing, and fully to be complete and ended: Provided always, that if the said James Hornsby,
Frederick Charles Southwell, and John Innocent, shall not, within three days after the granting of these
Letters of Registration, register the same in the proper office in the Supreme Court, at Sydney, in the said
Colony of New South Wales, then these Letters of Registration, and all advantages whatsoever hereby
granted, shall cease and become void.

In witness whereof, I have hereunto set my sign manual, and have caused the present Letters
of Registration to be sealed with the seal of the said Colony of New South Wales, at
Government House, Sydney, in New South Wales, this eighteenth day of November, in the
year of our Lord one thousand eight hundred and eighty-four.

[L.S.]

AUGUSTUS LOFTUS.

Improvements in Cradles for receiving and delivering cut crop, &c.

A.

SPECIFICATION of JAMES HORNSBY, FREDERICK CHARLES SOUTHWELL, and JOHN INNOCENT, all of the Spittlegate Iron Works, Grantham, in the county of Lincoln, England, engineers, for an invention, entitled "Improvements in Cradles for receiving and delivering cut crop from Harvesting Machines."

It is often desirable to retain for a time the crop cut by the harvester on the machine, and only allow it to drop to the ground at intervals. This is especially the case with self binding reapers for, by collecting several sheaves on the machine, and dropping them at intervals so as to form rows across the field, the operation of stooking is performed in very much less time than when the sheaves are deposited all over the field as they are bound.

The apparatus by which we effect this consists of a cradle or carrier mounted alongside the sheaf-binder.

This cradle is made in two parts, that part furthest from the sheaf-binder consisting, by preference, of several metallic bars of wrought iron or steel. These bars are attached to an axis, and are free to vibrate on this axis. The lower part of these bars are ordinarily in a nearly horizontal position, the outer part of them being curved upwards, and attached to an axis mounted on suitable supports attached to any convenient part of the machine.

The other part of the cradle consists of (by preference) a board, or it may be laths or metallic prongs. That side of the board next to the sheaf-binder is jointed to suitable supports, while the other side of the board towards the middle of the cradle is free to fall when it is desired to deposit the sheaves on the ground.

The two parts of the cradle are connected by a rod, so that when the board falls the prongs are caused to turn backwards, and thus the cradle opens at about its centre, one part turning down towards the machine, and the other part turning down away from the machine. The sheaves are thus deposited on the ground, the cradle being so constructed that its own weight, and the weight of the sheaves, causes it when released to open sufficiently to leave the sheaves. When, by the forward motion of the machine, the cradle has passed clear of the sheaves, it is caused by a foot or hand lever to return to its original position, and is there held to receive other sheaves to be carried forward and dropped as may be desired.

Instead of forming the cradle in two halves as above described, it may be made in one. In this case it consists of a series of wood or iron bars by the side of, and a little below the sheaf-binder.

These bars lie in the direction that the machine travels when working, and are supported at or about their centre, or forward of the centre of their length, by a bar fixed to the framing of the machine, with or without projections between the bars to help to deliver the sheaves.

If desirable, this supporting bar may have friction pulleys attached to it, or the bar itself may be a roller, so as to allow the bars carrying the sheaf more easily to be drawn from under the sheaves.

The series of bars that carry the sheaves may all be connected at the front end to a lever to be operated by the driver.

When a sufficient number of sheaves have been bound, and laid upon these carrying bars, the attendant deposits the sheaves by moving the bars forward, thus drawing them from under the sheaves and allowing them to fall upon the ground.

If it is desirable the bars may have a rocking movement on their support, the front end of the bars rising, and the back end falling while they are being moved forward as above described, thus giving them a more effectual tendency to deliver the sheaves.

DESCRIPTION OF THE DRAWINGS.

Figures 1, 2, and 3, are a back view, a plan, and a front view of part of a Hornsby Self-binding Reaper, provided with a cradle constructed according to our invention. In these figures the cutting apparatus and platform are omitted. It is situated to the left of figures 1 and 2, and to the right of fig. 3.

a is the driver's seat, *b b* are the two endless bands or sheets, which carry the cut crop over the main driving wheel *c* and deliver it on to the inclined board *d*, down which it slides on to the arms *e*, which hold it whilst being tied by the binding apparatus, and which are then withdrawn to allow the sheaf to fall on to the ground when the machine is not provided with a cradle, or into the cradle in the present case. All this is old and well known, and requires no further description.

A is a board which forms one-half of the cradle, and the rod *B*, with its four arms *B' B' B' B'* is the other half. The bearings in which the rod *B* is free to turn are carried at the ends of the bars *CC'*, which are fixed to the frame of the machine. The bar *C*, at the back of the machine, inclines upwards, as shown, to insure its clearing as the machine moves forward, the sheaves which have been dropped on to the ground. The side of the board *A*, nearest to the machine, has fixed to it a bar *A'*, one end of which is carried in a bearing at the end of a bracket *D* fixed to the frame of the machine, the other end being carried by a bearing in the bar *C'*. The bar *A'* and rod *B* have fixed to them levers *EE'*, whose ends are coupled by the connecting rod *F*, so that the two halves of the cradle open and close together. It will be observed that the board *A*, and arms *B'* are so hung that the cradle tends to fly open unless restrained.

The drawings show three ways of holding the cradle closed. In fig. 1 the rod *B* has fixed to its back end a lever *G*, to the end of which is pivoted a rod *H*, having a handle *H'* within the reach of the driver. To close the cradle the driver pushes the rod *H* from him until a notch on its under-side catches on a pin *H''*, which prevents the rod from returning until it is released by the driver, when the weight of the sheaves and cradle again force it back towards the driver. Fig. 4 is a similar view to fig. 1. Here the cradle is closed by a cord *J* attached to the end of a lever *K*, fixed to the rod *B*. The cord *J* passes over a pulley on the frame of the machine, and down to a foot lever controlled by the driver. By raising his foot the driver allows the cradle to open and discharge the sheaves, and he then closes it by again pressing down his foot. This arrangement is also shown in plan in fig. 2. Fig. 3 shows a similar arrangement, but in this case the cord is at the front instead of at the back, being attached to the end of the lever *L* fixed to the bar *A'*. The cord passes over pulleys on the frame, and then back to the foot lever as shown.

In

Improvements in Cradles for receiving and delivering cut crop, &c.

In figures 1, 2, and 4, the cradle is shown closed and containing three sheaves, whilst a fourth has just been tied, and is about to be allowed to drop into the cradle. The positions of the parts when the cradle is open are shown in dotted lines. In fig. 3 the cradle is shown open, having just dropped four sheaves; the positions of the parts when the cradle is closed are shown in dotted lines.

Figures 5 and 6 show a modification of the cradle. Fig. 5 is a side elevation, and fig. 6 a plan. As before, *a* is the driver's seat; *c* is the main driving wheel. The machine moves in the direction of the arrows. In this arrangement the cradle consists of a bar *M*, provided with straight rods *N*, which rest on bars *OO* fixed to the frame of the machine. To discharge the sheaves the cradle is drawn forwards into the position shown by the dotted lines. This is done by means of the lever *P*, which is pivoted at *P'* to the frame of the machine, and having one end connected to the cradle and the other to the rod *Q*, which is provided with a handle *Q'* within the reach of the driver. By pulling the rod *Q* towards him the driver draws the cradle forward, thus discharging the sheaves, and he then replaces the cradle by pushing the rod *Q* away from him.

Having now described the nature of our said invention, and the manner of performing the same, we would have it understood that we do not confine ourselves to the exact details shown, but that what we claim is:—

First—A cradle made in two parts, and opening at about the centre to allow the cut crop to drop out, substantially as described.

Second—A cradle made, as above claimed, in which the two halves are so hung that their own weight, and the weight of the cut crop, tends to open the cradle when released, substantially as described.

Third—A cradle made so as to discharge the cut crop by being drawn forward, substantially as described.

In witness whereof, we, the said James Hornsby, Frederick Charles Southwell, and John Innocent, have hereunto set our hands and seals, this eighteenth day of August, 1884.

JAMES HORNSBY.
FREDERICK CHARLES SOUTHWELL.
JOHN INNOCENT.

This is the specification, marked A, referred to in the annexed Letters of Registration granted to James Hornsby, Frederick Charles Southwell, and John Innocent, the eighteenth day of November, A.D. 1884.

AUGUSTUS LOFTUS.

REPORT.

Sir,

Sydney, 13 October, 1884.

We do ourselves the honor to report, in reply to your blank cover of the 4th instant, transmitting Messrs. Hornsby, Southwell, and Innocent's petition for the registration of an invention, entitled "Improvements in Cradles for receiving and delivering cut crop from Harvesting Machines," that we are of opinion the prayer of the petitioners may be granted in terms of their specification, drawings, and claim.

We have, &c.,

EDMUND FOSBERY.
GOTHEK K. MANN.

The Under Secretary of Justice.

[Drawings—three sheets.]

Fig. 3.

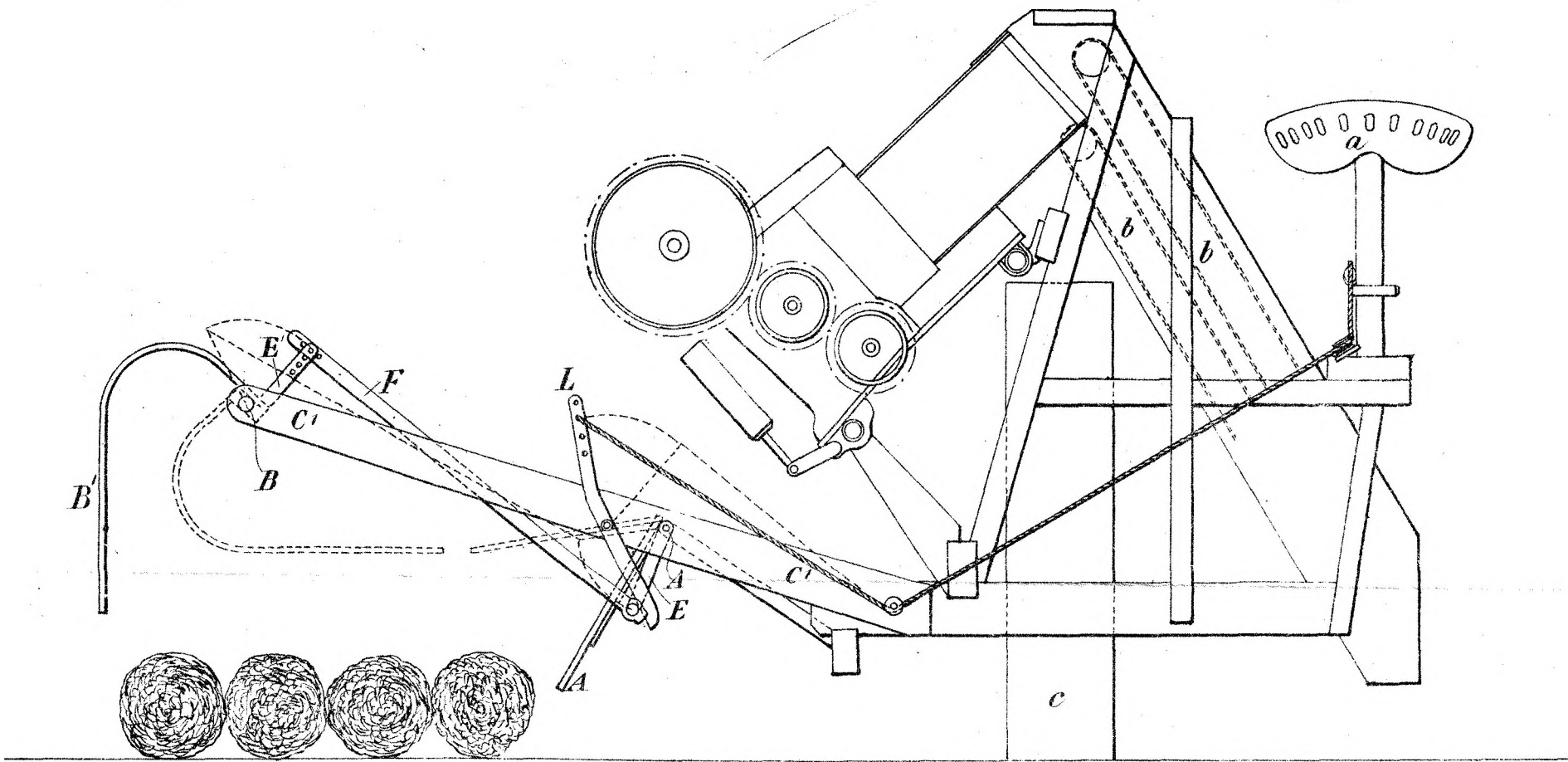
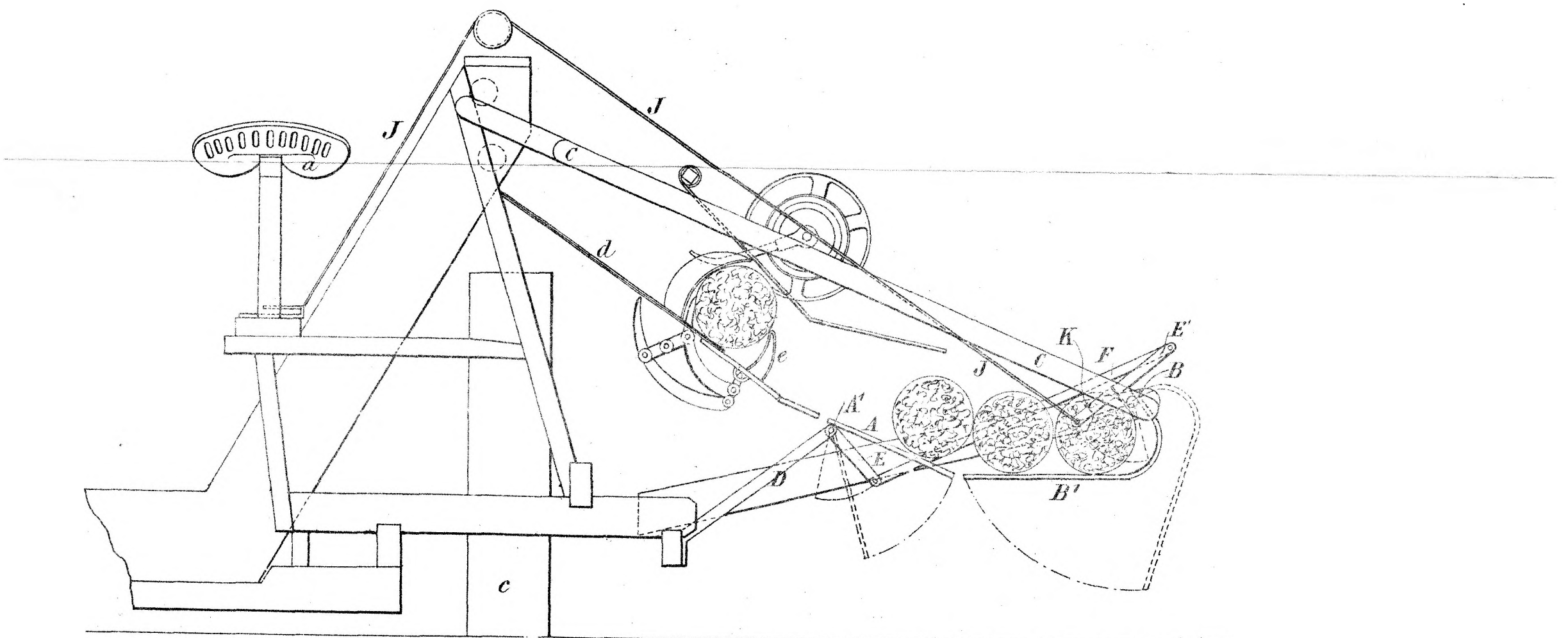


Fig. 4.



(Sig. 245~)

Fig. 1.

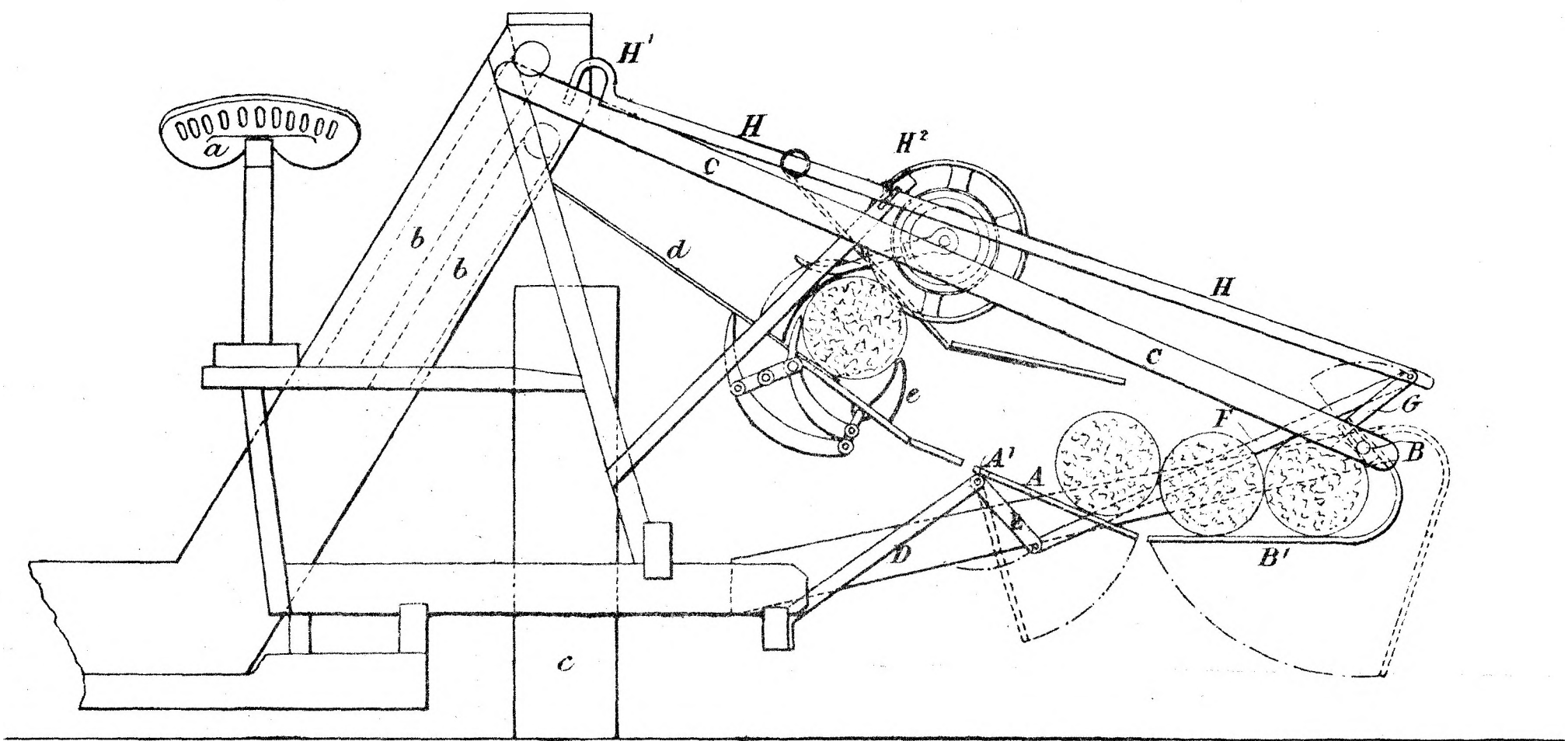
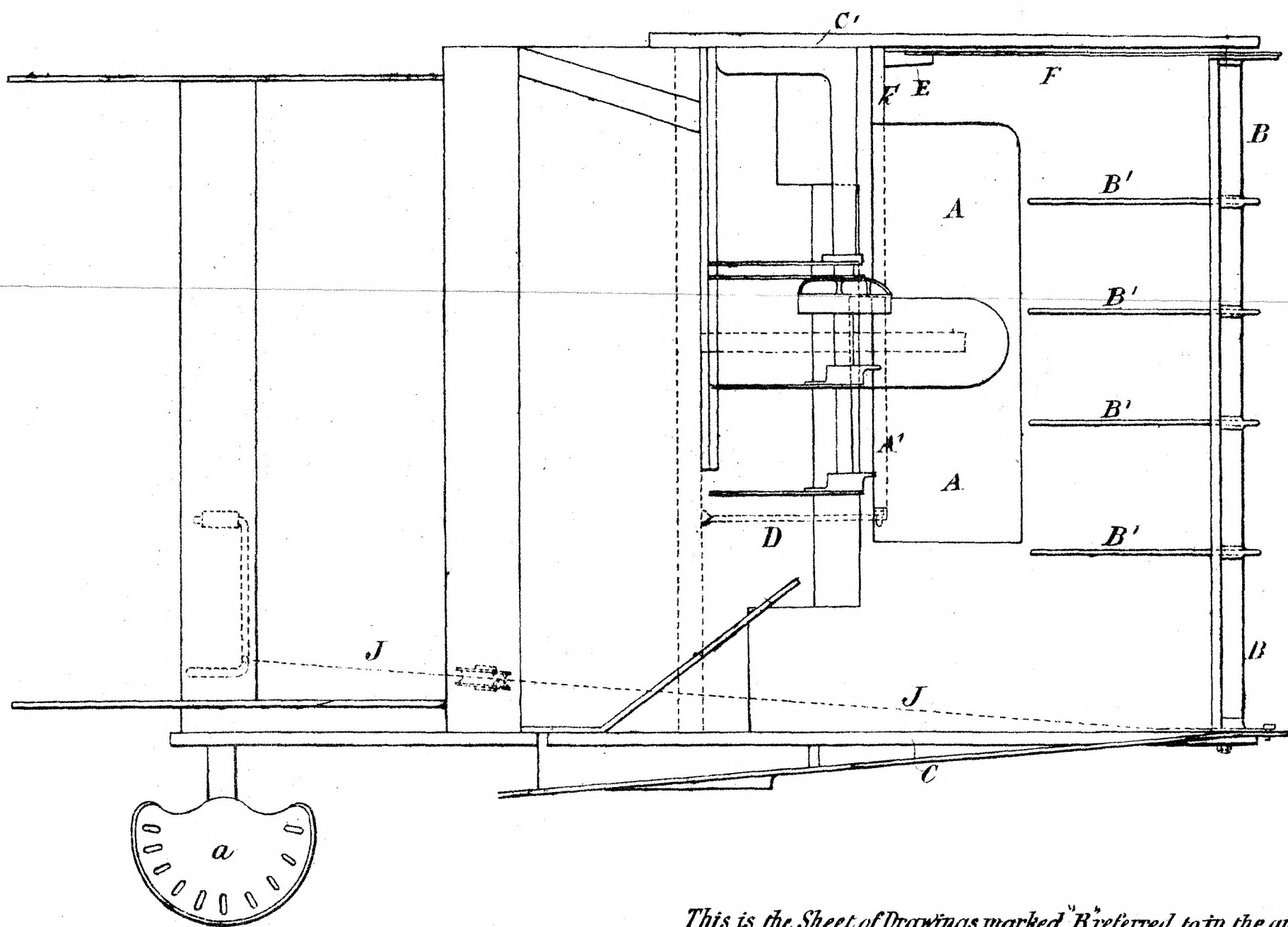


Fig. 2.



(Sig. 245-)

This is the Sheet of Drawings marked B, referred to in the annexed
 Letters of Registration granted to James Hornsby, Frederick Charles
 Southwell, and John Innocent the eighteenth day of November,
 A.D., 1884.
 Augustus Loftus.

Fig. 5.

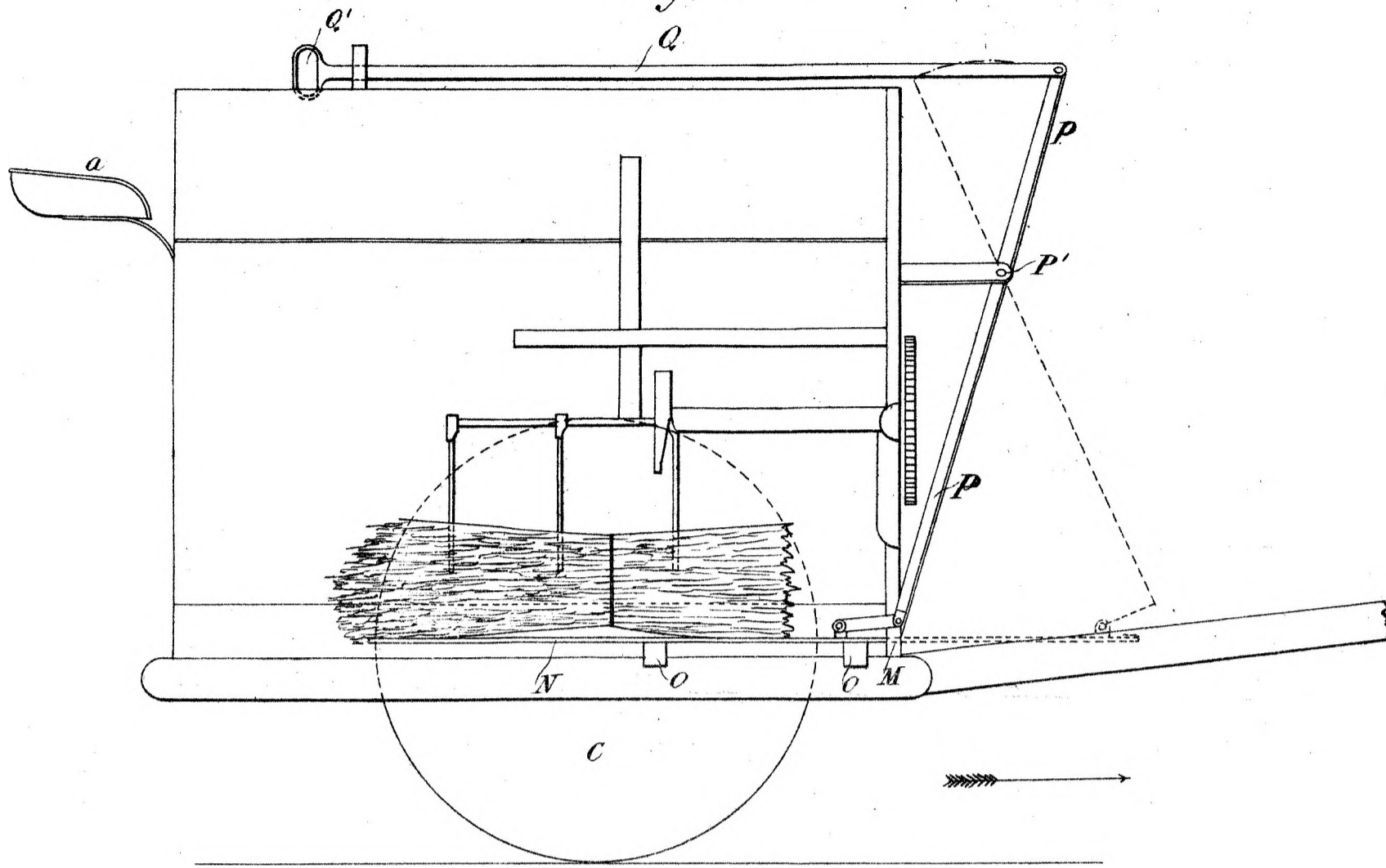
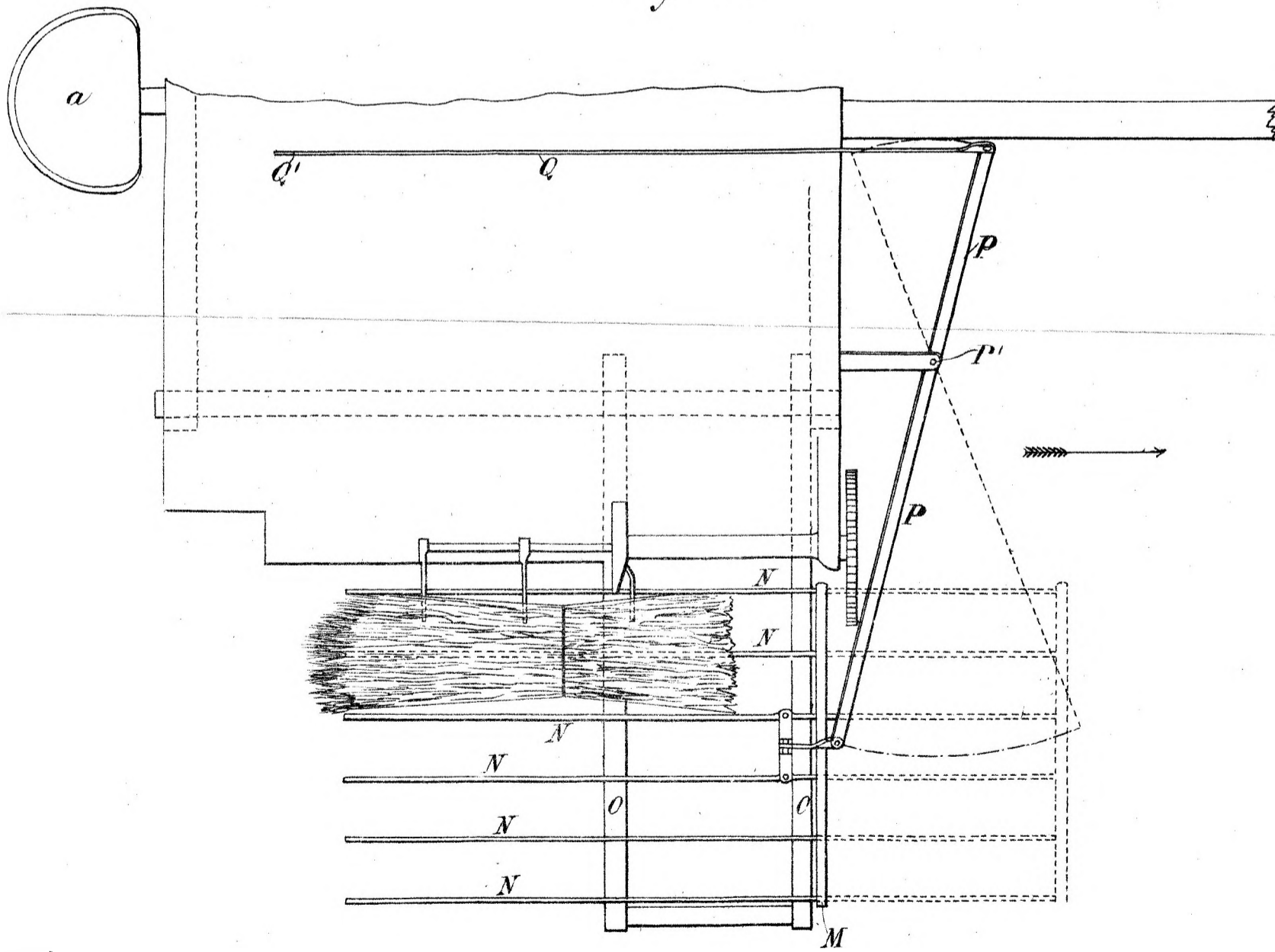


Fig. 6.



(Sig. 245-)

This is the Sheet of Drawings marked D, referred to in the annexed Letters of Registration, granted to James Hornsby, Frederick Charles Southwell, and John Innocent the eighteenth day of November, A. D., 1884. Augustus Loftus.



A.D. 1884, 18th November. No. 1533.

IMPROVEMENTS IN APPARATUS FOR SHEARING SHEEP.

LETTERS OF REGISTRATION to Frederick York Wolseley and Richard Pickup Park, for Improvements in Apparatus for Shearing Sheep.

[Registered on the 18th day of November, 1884, in pursuance of the Act 16 Vic. No. 24.]

BY HIS EXCELLENCY THE RIGHT HONORABLE SIR AUGUSTUS WILLIAM FREDERICK SPENCER LOFTUS (commonly called LORD AUGUSTUS LOFTUS), Knight Grand Cross of the Most Honorable Order of the Bath, a Member of Her Majesty's Most Honorable Privy Council, Governor and Commander-in-Chief of the Colony of New South Wales and its Dependencies.

TO ALL TO WHOM THESE PRESENTS SHALL COME, greeting :

WHEREAS FREDERICK YORK WOLSELEY, of Walgett, in the Colony of New South Wales, gentleman, and RICHARD PICKUP PARK, of Yarra Bank, Melbourne, in the Colony of Victoria, engineer, have by their Petition humbly represented to me that they are the authors or designers of a certain invention or improvement in manufactures, that is to say, of an invention entitled, "Improvements in Apparatus for Shearing Sheep," which is more particularly described in the specification and the sheet of drawings which are hereunto annexed; and that they, the said Petitioners, have deposited with the Honorable the Treasurer of the said Colony of New South Wales the sum of Twenty Pounds sterling, for defraying the expense of granting these Letters of Registration, as required by the Act of Council, sixteenth Victoria, number twenty-four; and have humbly prayed that I would be pleased to grant Letters of Registration whereby the exclusive enjoyment and advantage of the said invention or improvement might be secured to them for a period of fourteen years: And I, being willing to give encouragement to all inventions and improvements in the arts or manufactures which may be for the public good, and having received a report favourable to the prayer of the said Petition from competent persons appointed by me to examine and consider the matters stated therein and to report thereon for my information, am pleased, with the advice of the Executive Council, and in exercise of the power and authority given to me by the said Act of Council, to grant, and do by these Letters of Registration grant unto the said Frederick York Wolseley and Richard Pickup Park, their executors, administrators, and assigns, the exclusive enjoyment and advantage of the said invention or improvement, for and during the term of fourteen years from the date hereof; to have, hold, and exercise unto the said Frederick York Wolseley and Richard Pickup Park, their executors, administrators, and assigns, the exclusive enjoyment and advantage thereof, for and during and unto the full end and term of fourteen years from the date of these presents next and immediately ensuing, and fully to be complete and ended: Provided always, that if the said Frederick York Wolseley and Richard Pickup Park shall not, within three days after the granting of these Letters of Registration, register the same in the proper office in the Supreme Court, at Sydney, in the said Colony of New South Wales, then these Letters of Registration, and all advantages whatsoever hereby granted, shall cease and become void.

In witness whereof, I have hereunto set my sign manual, and have caused the present Letters of Registration to be sealed with the seal of the said Colony of New South Wales, at Government House, Sydney, in New South Wales, this eighteenth day of November, in the year of our Lord one thousand eight hundred and eighty-four.

[L.S.]

AUGUSTUS LOFTUS.

Improvements in Apparatus for Shearing Sheep.

SPECIFICATION of FREDERICK YORK WOLSELEY, of Walgett, in the Colony of New South Wales, gentleman, and RICHARD PICKUP PARK, of Yarra Bank, Melbourne, in the Colony of Victoria, engineer, for an invention entitled "Improvements in Apparatus for Shearing Sheep."

OUR invention of improvements in apparatus for shearing sheep relates mainly to the contrivances for communicating motion to the cutter from a flexible driving gear—the particular kind of such flexible driving gear which we prefer forming the subject matter of another invention which we intend to patent. Our shearing apparatus is nearly all contained in a suitable casing, which is made in two parts, a top and a bottom one, to the latter of which the apparatus is connected at various points. The former is connected to the latter by spring catches, but can be readily disconnected whenever so required. The upper part is again divided into two unequal parts, hinged on one common centre, but the foremost is the smaller part, while the latter forms the top of that part of the casing which is held by the hand.

Referring to our drawing, figure 1 shows a plan of the top side of a sheep-shearing apparatus constructed according to our invention, but having the covers at both ends broken off, in order to show more clearly the contained operating mechanism. Figure 2 is a longitudinal sectional elevation, and figure 3 a plan of the underside of our apparatus. Figure 4 is a vertical section at line *a a*, figure 1; figure 5 a plan of the reciprocating crank D^2 , and figure 6 a plan of the cross-head D^9 .

In these figures, A is the upper and A^1 the lower half of the casing, the upper half being in two parts, hinged together at A^2 . At the end of the foremost part are slotted projections A^3 , which fit between the sides of the lower half, and are held there by the catch A^4 , which is actuated by the spiral springs A^5 . A^6 A^6 are guide pieces, and A^7 the spring catch at the back end, for connecting the upper part to the lower. B is a neck projecting from the back end of said casing, and having the bush B^1 screwed therein, which, together with the hole provided in the neck, form a bearing for the spindle B^2 , on which is screwed the mitre wheel B^3 . Screwed on to its hinder end is the one half of the radiating gear C , which is within the swivel C^1 , centred and connected by pins C^2 with its outward half C^3 , in which is the inner bush C^4 , to provide a bearing for the spindle C^5 , carrying the outer half of the gearing C . These parts from C to C^5 form a universal joint or connection between the shearing apparatus and the driving spindle C^5 , so as to allow of it being operated at any angle within the range of such universal joint. B^4 is a horizontal mitre wheel, working on a pin B^5 , which is screwed into the lower casing A^1 , and is provided with the jamb nut B^6 . B^7 is a crank pin, secured to the top of said mitre wheel, on which to attach the eye of the connecting rod B^8 , whose eye at its other end works on the pin D , secured to the arm D^1 of the reciprocating crank piece D^2 , which is centred, and works on the vertical pin D^3 , secured to the lower casing by the nut D^4 , as shown. The crank piece D^2 has another arm or tail piece D^5 , bent upwards, which supports the pin D^6 of the forked operating arm D^7 , which is attached to the shear-cutter or knife E by the pins D^8 D^8 . D^9 is a cross-head, which fits around the upper boss D^{10} of the crank piece D^2 , and rests in the semicircular recesses formed in the arms of said operating piece D^7 . D^{11} is a washer fitting on the square on the pin D^3 , which is screwed at its uppermost end to receive the nut D^{12} , the outer periphery of which is toothed as shown, so as to admit of its being locked at any desired position by the pin D^{13} , projecting downwards from the inner face of the upper casing A . An oil-cup is formed in the upper part of nut D^{12} , and oil-cups are also formed as shown on the eyes of the connecting rod B^8 . E^1 is the comb or lower half of the cutting appliance, formed with a number of teeth E^2 , as shown, and having the oblong holes E^3 in it, through which pass the screws E^4 , for securing it to the lower outer face of the casing A^1 .

The mode of operation is as follows:—Motion being imparted to the spindle C^5 , causes the whole of the encased mechanism to be set in motion, thereby giving to the upper shear or cutter B a to-and-fro reciprocating motion across the face of the teeth D^2 of the lower fixed cutter or comb E^1 , so that when the operator brings it into contact with the wool on the sheep the said wool is sheared or clipped off as fast as it is brought within the spaces of the teeth of the comb.

Having thus described the nature of our invention, and the manner of performing same, we would have it understood that we specially disclaim the invention of knives or cutters reciprocating over a comb for shearing sheep, but what we believe to be new, and therefore claim as our improvements in apparatus for shearing sheep, is—

First—The combination of the parts marked from D to D^{13} with the cutter E and the fixed comb E^1 , substantially as herein described and explained, and as illustrated in our drawings.

Second—The combination of the parts marked from A^1 to B^5 for communicating motion to the shearing mechanism, substantially as herein described and explained, and as illustrated in our drawings.

In witness whereof, we, the said Frederick York Wolseley and Richard Pickup Park, have hereto set our hands and seals, this sixth day of October, one thousand eight hundred and eighty-four.

F. Y. WOLSELEY.
R. P. PARK.

Witness to the signature of Frederick York Wolseley—
LANGTON PARKER, J.P., Bangate.

Witness to the signature of Richard Pickup Park—
EDWD. WATERS, Melbourne, Patent Agent.

This is the specification referred to in the annexed Letters of Registration granted to Frederick York Wolseley and Richard Pickup Park, the eighteenth day of November, A.D. 1884.

AUGUSTUS LOFTUS.

REPORT.

Sir,

Sydney, 13 October, 1884.

We do ourselves the honor to report, in reply to your blank cover of the 9th instant, transmitting Messrs. Wolseley and Park's petition for the registration of an invention entitled "Improvements in Apparatus for Shearing Sheep," that we are of opinion the prayer of the Petitioners may be granted in terms of their specification, drawings, and claim.

We have, &c.,
GOTHER K. MANN.
EDMUND FOSBERY.

The Under Secretary of Justice.

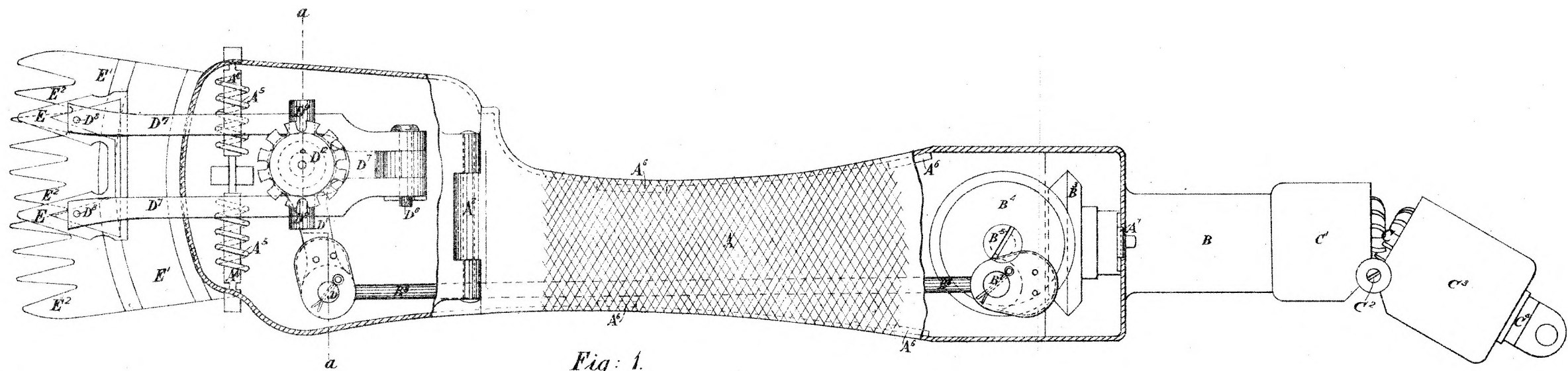


Fig: 1.

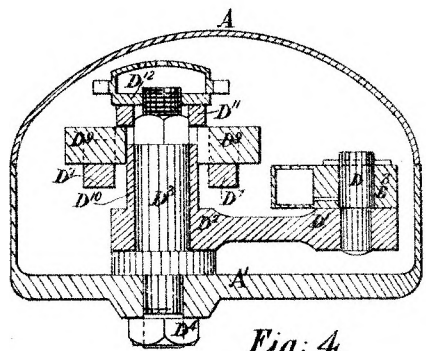


Fig: 4.

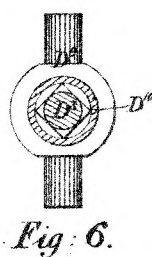


Fig: 6.

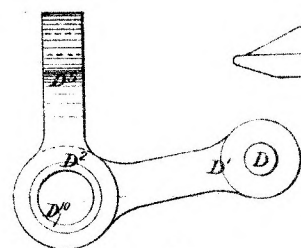


Fig: 5.

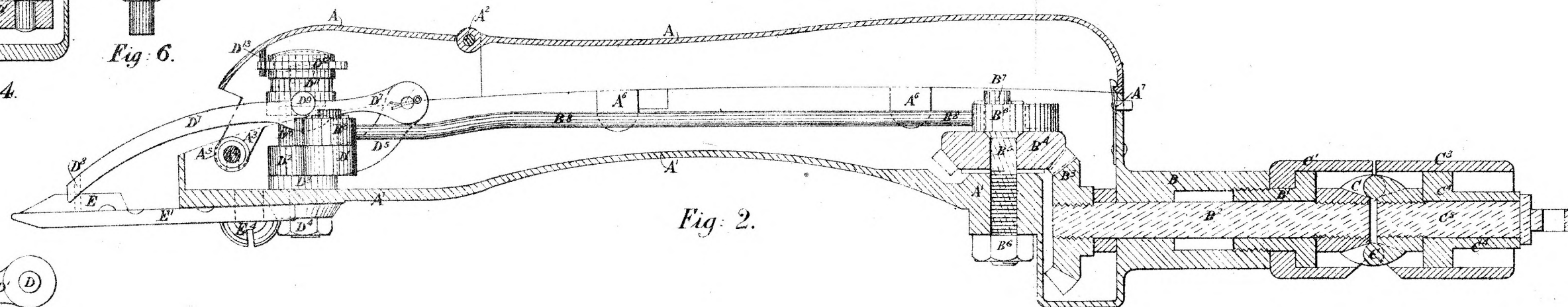


Fig: 2.

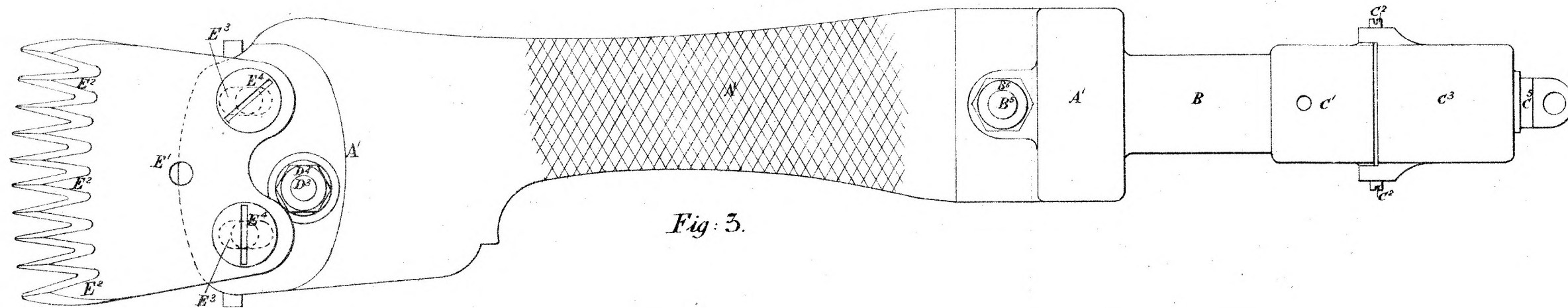


Fig: 3.

(Sig 245)

PHOTO-LITHOGRAPHED AT THE GOVT. PRINTING OFFICE, SYDNEY, NEW SOUTH WALES.

This is the Sheet of Drawings referred to in the annexed Letters of Registration, granted to Frederick York Wolseley, and Richard Pickup Part: 2, the Eighteenth day of November, A. D., 1884.

Augustus Loftus.



A.D. 1884, 18th November. No. 1534.

IMPROVEMENTS IN MACHINERY FOR DRYING WOOL OR OTHER SUBSTANCES.

LETTERS OF REGISTRATION to George Burnell, for Improvements in Machinery for drying Wool or other substances.

[Registered on the 18th day of November, 1884, in pursuance of the Act 16 Vic. No. 24.]

BY HIS EXCELLENCY THE RIGHT HONORABLE SIR AUGUSTUS WILLIAM FREDERICK SPENCER LOFTUS (commonly called LORD AUGUSTUS LOFTUS), Knight Grand Cross of the Most Honorable Order of the Bath, a Member of Her Majesty's Most Honorable Privy Council, Governor and Commander-in-Chief of the Colony of New South Wales and its Dependencies.

TO ALL TO WHOM THESE PRESENTS SHALL COME, greeting :

WHEREAS GEORGE BURNELL, of Hindmarsh, in the Province of South Australia, woolstapler, hath by his Petition humbly represented to me that he is the author or designer of a certain invention or improvement in manufactures, that is to say, of an invention entitled "Improvements in Machinery for drying Wool or other substances," which is more particularly described in the specification and the sheet of drawings which are hereunto annexed ; and that he, the said Petitioner, hath deposited with the Honorable the Treasurer of the said Colony of New South Wales the sum of Twenty Pounds sterling, for defraying the expense of granting these Letters of Registration, as required by the Act of Council, sixteenth Victoria, number twenty-four ; and hath humbly prayed that I would be pleased to grant Letters of Registration, whereby the exclusive enjoyment and advantage of the said invention or improvement might be secured to him for a period of fourteen years : And I, being willing to give encouragement to all inventions and improvements in the arts or manufactures which may be for the public good, and having received a report favourable to the prayer of the said Petition from competent persons appointed by me to examine and consider the matters stated therein, and to report thereon for my information, am pleased, with the advice of the Executive Council, and in exercise of the power and authority given to me by the said Act of Council, to grant, and do by these Letters of Registration grant unto the said George Burnell, his executors, administrators, and assigns, the exclusive enjoyment and advantage of the said invention or improvement, for and during the term of fourteen years from the date hereof ; to have, hold, and exercise unto the said George Burnell, his executors, administrators, and assigns, the exclusive enjoyment and advantage thereof, for and during and unto the full end and term of fourteen years from the date of these presents next and immediately ensuing, and fully to be complete and ended : Provided always, that if the said George Burnell shall not, within three days after the granting of these Letters of Registration, register the same in the proper office in the Supreme Court, at Sydney, in the said Colony of New South Wales, then these Letters of Registration, and all advantages whatsoever hereby granted, shall cease and become void.

In witness whereof, I have hereunto set my sign manual, and have caused the present Letters of Registration to be sealed with the seal of the said Colony of New South Wales, at Government House, Sydney, in New South Wales, this eighteenth day of November, in the year of our Lord one thousand eight hundred and eighty-four.

[L.s.]

AUGUSTUS LOFTUS.

Improvements in Machinery for drying Wool or other substances.

TO ALL TO WHOM THESE PRESENTS SHALL COME: I, GEORGE BURNELL, of Hindmarsh, in the Province of South Australia, woolstapler, send greeting:

WHEREAS, I, the said George Burnell, am the inventor of certain improvements for "Improvements in Machinery for drying Wool or other substances." Now know ye that I, the said George Burnell, do hereby declare the nature of my said improvements, and in what manner the same are to be performed, to be particularly described and ascertained in and by the following statement, that is to say:—My invention consists of an apparatus for more expeditiously drying wool than by the methods at present in use, and is fully explained and described in the following statement, reference being made by letters to the drawings deposited herewith. I take several iron rings A, and fixed on the inside of such rings longitudinal piece or ribs of timber B, thus forming a skeleton cylinder, which cylinder is then covered with wire or wire netting C. The number of rings required depends on the length of the cylinder. The ribs are triangular pieces of timber, and to these I fix on upper side metal shelves D. These shelves are curved upwards and terminate in a serrated edge, the sharp pointed teeth being curved still further back. The whole cylinder rests on a number of grooved rollers E, in which the iron rings above referred to run, and it is revolved by means of a small toothed pinion F or pinions gearing into a toothed ring or rings. The whole machine is mounted on a framework G & G, which is fixed higher at the feeding end than the back end, the object of this is to cause the wool or other material to travel downwards and thus make the action of the apparatus continuous.

DESCRIPTION OF DRAWINGS.

Fig. 1 is a perspective view of skeleton cylinder.

Fig. 2 is an end view looking through cylinder.

Fig. 3 is a side view showing the wirework and the mode of fixing it. When wire netting is used, it is put on in strips and the ends are brought together on one of the longitudinal ribs and fixed with staples.

METHOD OF WORKING.

I will now describe how my invention is worked. The cylinder is made to revolve in the direction in which the shelves point by the pinion F being operated, and the wool or other material is fed in and falls on the ribs and shelves. In the course of the revolution the wool is thrown off the shelves, and is caught, or a portion of it, by the sharp pointed teeth, and is thus suspended and exposed to the action of the atmosphere. The frame being tilted, the wool as it is discharged from the shelves or becomes disengaged from the teeth, falls to the bottom, and in doing so, goes a few inches further into the cylinder; and thus continuously until it arrives at the lower end, where it is discharged dry. The cylinder is mounted in such a way and placed in such a position as to enable the wind to pass through it in all directions. As a rule this will be sufficient to secure the thorough drying of the wool in its passage through the cylinder, but if the cylinder is short or a more rapid process of drying is required, the cylinder may be heated by means of a furnace and flues; or steam pipes may be applied when the weather is damp and wet.

CLAIM.

Having fully described my invention, and the manner in which it is worked, I wish it to be distinctly understood that what I claim as my invention and wish to be protected is:—

First—A cylindrical apparatus, substantially as described, with iron rings A, timber or metal ribs B, and metal-edged shelves D, for the purpose of drying wool or other material.

Second—Several series of grooved friction rollers E to facilitate the revolution of the cylinder.

Third—The pinion or pinions F, with accompanying gearing, as applied to wool-drying apparatus, for the purpose of revolving the cylinder. I do not confine myself to the exact sizes or dimensions of the various parts shown; but those indicated in the drawings are those likely to be most generally in use. The sizes of the apparatus will vary according to the amount of work to be accomplished.

In witness whereof, I have hereunto set my hand and seal, this second day of October, in the year of our Lord one thousand eight hundred and eighty-four.

Witness—

JNO. FAIRFAX CONIGRAVE, Licensed Patent Agent.

CHARLES N. COLLISON, Licensed Land Broker.

GEORGE BURNELL.

This is the specification referred to in the annexed Letters of Registration granted to George Burnell, the 18th day of November, A.D. 1884.

AUGUSTUS LOFTUS.

REPORT.

Sir,

Sydney, 13 October, 1884.

We do ourselves the honor to report, in reply to your blank cover of the 9th instant, transmitting Mr. George Burnell's petition for the registration of an invention entitled "Improvements in Machinery for drying Wool and other substances," that we are of opinion the prayer of the petitioner may be granted in terms of his specification and drawings.

We have, &c.,

GOTHER K. MANN.
EDMUND FOSBERY.

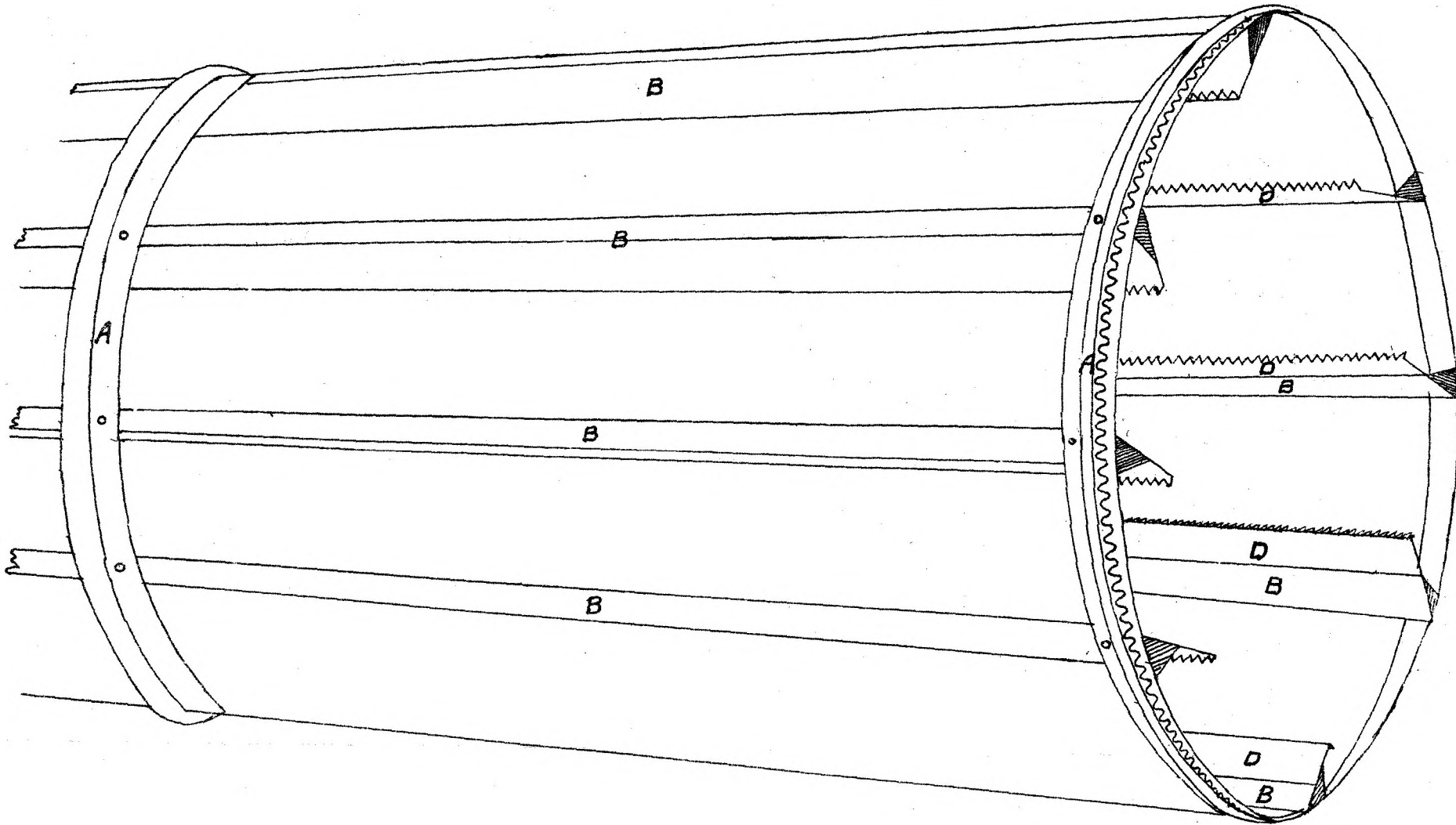
The Under Secretary of Justice.

[Drawings—one sheet.]

No. 1535.

[Assignment of No. 1384. See Letters of Registration for 1884, page 113.]

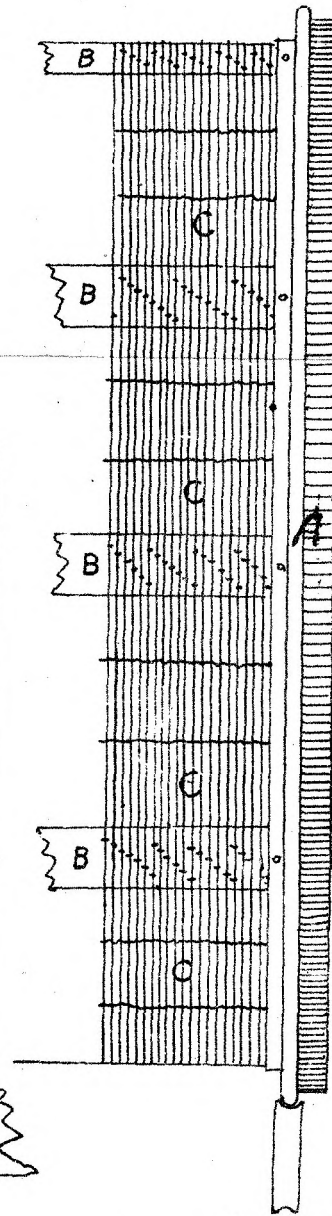
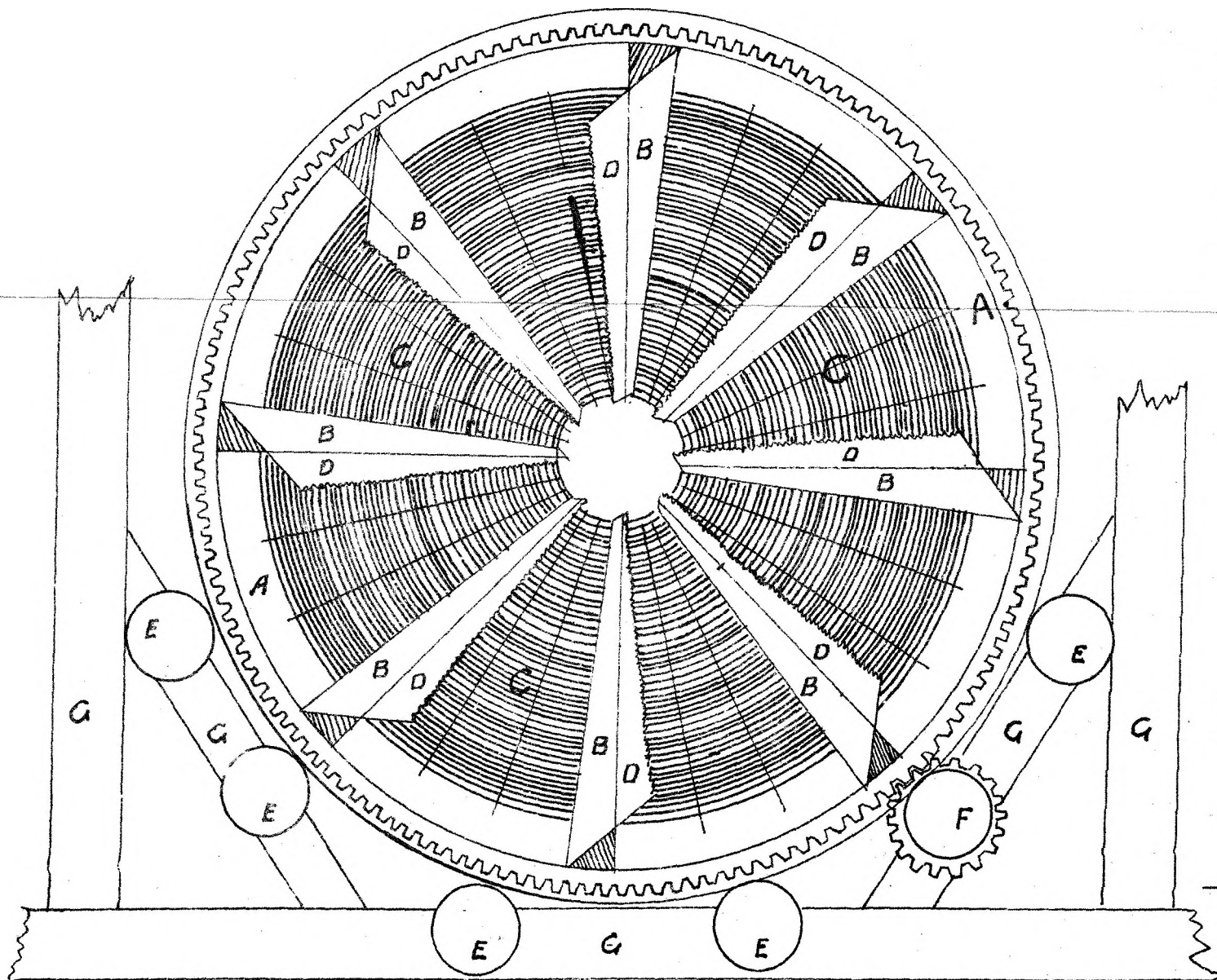
FIG. 1.



SCALE. 1 INCH TO A FOOT.

FIG. 2.

FIG. 3.



This is the Sheet of Drawings referred to in the annexed Letters of Registration, granted to George Burnell, the eighteenth day of November, A.D. 1884.

Augustus Loftus.

(Sig 245-)



A.D. 1884, 1st December. No. 1536.

IMPROVEMENTS IN THE EXTRACTION OF COBALT, NICKEL, AND MANGANESE
FROM THEIR ORES.

LETTERS OF REGISTRATION to Henri Herrenschmidt for Improvements in
the extraction of cobalt, nickel, and manganese from their ores.

[Registered on the 2nd day of December, 1884, in pursuance of the Act 16 Vic. No. 24.]

BY HIS EXCELLENCY THE RIGHT HONORABLE SIR AUGUSTUS WILLIAM FREDERICK SPENCER LOFTUS
(commonly called LORD AUGUSTUS LOFTUS), Knight Grand Cross of the Most Honorable Order of
the Bath, a Member of Her Majesty's Most Honorable Privy Council, Governor and Commander-in-
Chief of the Colony of New South Wales and its Dependencies.

TO ALL TO WHOM THESE PRESENTS SHALL COME, greeting :

WHEREAS HENRI HERRENSCHMIDT, of Bondi, near Sydney, in the Colony of New South Wales, metallurgist, hath by his Petition humbly represented to me that he is the author or designer of a certain invention or improvement in manufactures, that is to say, of an invention entitled "Improvements in the extraction of cobalt, nickel, and manganese from their ores," which is more particularly described in the amended specification which is hereunto annexed; and that he, the said Petitioner, hath deposited with the Honorable the Treasurer of the said Colony of New South Wales the sum of Twenty Pounds sterling, for defraying the expense of granting these Letters of Registration, as required by the Act of Council, sixteenth Victoria, number twenty-four; and hath humbly prayed that I would be pleased to grant Letters of Registration, whereby the exclusive enjoyment and advantage of the said invention or improvement might be secured to him for a period of fourteen years: And I, being willing to give encouragement to all inventions and improvements in the arts or manufactures which may be for the public good, and having received a report favourable to the prayer of the said Petition, from competent persons appointed by me to examine and consider the matters stated therein and to report thereon for my information, am pleased, with the advice of the Executive Council, and in exercise of the power and authority given to me by the said Act of Council, to grant, and do by these Letters of Registration grant unto the said Henri Herrenschmidt, his executors, administrators, and assigns, the exclusive enjoyment and advantage of the said invention or improvement, for and during the term of fourteen years from the date hereof; to have, hold, and exercise unto the said Henri Herrenschmidt, his executors, administrators, and assigns, the exclusive enjoyment and advantage thereof, for and during and unto the full end and term of fourteen years from the date of these presents next and immediately ensuing, and fully to be complete and ended: Provided always, that if the said Henri Herrenschmidt shall not, within three days after the granting of these Letters of Registration, register the same in the proper office in the Supreme Court, at Sydney, in the said Colony of New South Wales, then these Letters of Registration, and all advantages whatsoever hereby granted, shall cease and become void.

In witness whereof, I have hereunto set my sign manual, and have caused the present Letters of Registration to be sealed with the seal of the said Colony of New South Wales, at Government House, Sydney, in New South Wales, this first day of December, in the year of our Lord one thousand eight hundred and eighty-four.

[L.S.]

AUGUSTUS LOFTUS.

Improvements in the extraction of cobalt, nickel, and manganese from their ores.

SPECIFICATION of HENRI HERRENSCHMIDT, of Bondi, near Sydney, in the Colony of New South Wales, metallurgist, for an invention entitled "Improvements in the extraction of cobalt, nickel, and manganese from their ores."

THIS invention consists of improvements upon my "Improvements in the extraction of cobalt, nickel, and manganese from their ores, and nickel from its ores, when such ores are found in a similar condition to those of New Caledonia," for which I applied in conjunction with others, for Letters of Registration for New South Wales, on the sixteenth day of July, one thousand eight hundred and eighty-four, but its scope is not confined to those ores similar to New Caledonian ores.

These improvements consist essentially in the production of a proto-chloride of iron from cobalt nickel, manganese, and iron ore, and particularly from such of those ores as are found in Australia.

I take these ores and dissolve them in hydro-chloric acid or sulphuric acid and salt. The chlorine gas produced by the reaction may be used with advantage to separate the nickel from the cobalt, and the liquor which contains cobalt, nickel, manganese, and iron, I protoxidize by passing it over iron, or over any compound containing iron, which would protoxidize the liquor, such as copper either in pyrites or regulus, or iron pyrites, or a regulus produced by smelting gold or silver bearing pyrites, or otherwise. If copper is used in pyrites or regulus the copper is separated from the solution in the ordinary way by precipitating with iron. If pyrites or regulus obtained from auriferous pyrites are used the precious metals are recovered from the residue by any well known process. By this means I am enabled to produce the proto-chloride of iron without using metallic iron.

I claim—

First—The use of copper ores or regulus to protoxidize the metals contained in the liquor in which the ore has been dissolved, substantially as herein described and explained.

Second—The use of regulus containing gold and silver to protoxidize the metals contained in the liquor in which the ore has been dissolved, substantially as herein described and explained.

In witness whereof, I, the said Henri Herrenschnidmt, have hereto set my hand and seal, this fifteenth day of August, one thousand eight hundred and eighty-four.

H. HERRENSCHMIDT.

Witness—

FRED. WALSH,

Manager, E. Waters' Patent Office, Sydney.

This is the amended specification referred to in the annexed Letters of Registration granted to Henri Herrenschnidmt, the first day of December, A.D. 1884.

AUGUSTUS LOFTUS.

REPORTS.

Sir,

Sydney, 22 August, 1884.

The application of Mr. Herrenschnidmt for Letters of Registration for "Improvements in the extraction of cobalt, nickel, and manganese from their ores," having been referred to us, we have examined the specification accompanying the same, and have now the honor to report as follows:—Mr. Herrenschnidmt proposes to produce chloride of iron by boiling ores containing iron with hydro-chloric acid, but this process is included in a patent granted to John Clarke, 24th June, 1884, and the first claim must therefore be rejected. He then proposes to reduce the per-chloride to the condition of proto-chloride by passing it over iron. The reducing action of iron is well known and cannot in our view be protected. But the second and third claims do not include the use of iron, but only of "copper ore or regulus," and regulus containing gold and silver. We doubt if these compounds would have the effect intended, but as we are not aware that they have hitherto been used in this manner, we will offer no objection to Letters of Registration being granted for claims 2 and 3.

We have, &c.,

J. SMITH.

A. LEIBIUS.

The Under Secretary of Justice.

Sir,

Sydney, 24 September, 1884.

In the matter of the application of Mr. Herrenschnidmt for Letters of Registration for "Improvements in the extraction of cobalt, nickel, and manganese from their ores," in which we reported under date 22nd August, and which Mr. Herrenschnidmt has requested to be reconsidered, so far as the rejection of his first claim is concerned, we have carefully reviewed the question, and must adhere to our former decision.

The alteration of the word proto-chloride to per-chloride, which Mr. Herrenschnidmt desires to make, in no way affects the merits of the case.

We have, &c.,

J. SMITH,

A. LEIBIUS.

The Under Secretary of Justice.



A.D. 1884, 1st December. No. 1537.

THE CUP-HEADED SELF-ADJUSTING WIRE ROOFING NAIL.

LETTERS OF REGISTRATION to Alfred Robb and William Stokes for an invention entitled the "Cup-headed Self-adjusting Wire Roofing Nail, requiring no washer."

[Registered on the 2nd day of December, 1884, in pursuance of the Act 16 Vic. No. 24.]

BY HIS EXCELLENCY THE RIGHT HONORABLE SIR AUGUSTUS WILLIAM FREDERICK SPENCER LOFTUS (commonly called LORD AUGUSTUS LOFTUS), Knight Grand Cross of the Most Honorable Order of the Bath, a Member of Her Majesty's Most Honorable Privy Council, Governor and Commander-in-Chief of the Colony of New South Wales and its Dependencies.

TO ALL TO WHOM THESE PRESENTS SHALL COME, greeting :

WHEREAS ALFRED ROBB and WILLIAM STOKES, both of Wilson's Road, Christchurch, in the Colony of New Zealand, carpenters, have by their Petition humbly represented to me that they are the authors or designers of a certain invention or improvement in manufactures, that is to say, of an invention entitled "The Cup-headed Self-adjusting Wire Roofing Nail, requiring no washer," which is more particularly described in the specification which is hereunto annexed; and that they, the said Petitioners, have deposited with the Honorable the Treasurer of the said Colony of New South Wales the sum of Twenty Pounds sterling, for defraying the expense of granting these Letters of Registration, as required by the Act of Council, sixteenth Victoria number twenty-four; and have humbly prayed that I would be pleased to grant Letters of Registration, whereby the exclusive enjoyment and advantage of the said invention or improvement might be secured to them for a period of fourteen years: And I, being willing to give encouragement to all inventions and improvements in the arts or manufactures which may be for the public good, and having received a report favourable to the prayer of the said Petition, from competent persons appointed by me to examine and consider the matters stated therein and to report thereon for my information, am pleased, with the advice of the Executive Council, and in exercise of the power and authority given to me by the said Act of Council, to grant, and do by these Letters of Registration grant unto the said Alfred Robb and William Stokes, their executors, administrators, and assigns, the exclusive enjoyment and advantage of the said invention or improvement, for and during the term of fourteen years from the date hereof; to have, hold, and exercise unto the said Alfred Robb and William Stokes, their executors, administrators, and assigns, the exclusive enjoyment and advantage thereof, for and during and unto the full end and term of fourteen years from the date of these presents next and immediately ensuing, and fully to be complete and ended: Provided always, that if the said Alfred Robb and William Stokes shall not, within three days after the granting of these Letters of Registration, register the same in the proper office in the Supreme Court, at Sydney, in the said Colony of New South Wales, then these Letters of Registration, and all advantages whatsoever hereby granted, shall cease and become void.

In witness whereof, I have hereunto set my sign manual, and have caused the present Letters of Registration to be sealed with the seal of the said Colony of New South Wales, at Government House, Sydney, in New South Wales, this first day of December, in the year of our Lord one thousand eight hundred and eighty-four.

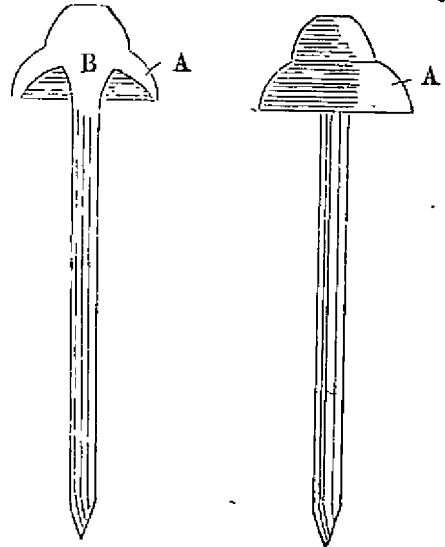
[L.S.]

AUGUSTUS LOFTUS.

The Cup-headed Self-adjusting Wire Roofing Nail.

SPECIFICATION of ALFRED ROBB and WILLIAM STOKES, both of Wilson's Road, Christchurch, in the Colony of New Zealand, carpenters, for an Invention intituled "The Cup-headed Self-adjusting Wire Roofing Nail, requiring no washer."

THE nail is constructed by moulding a soft metal head on to a wire nail in various sizes, the underneath of which is hollow or cupped, which causes it to adjust itself to the corrugated iron. There is a small cone formed in the hollow part of the head round the wire nail, as shown on section , which strengthens the head, and, when driven in, fills up the indent made in the iron when the point of the nails enter, thereby making a perfect fit, and leakage is impossible. It also saves the time and trouble of dressing down the heads or washers, which is required by all other roofing nails in use at present, which, if left undone (as is often the case with slovenly or inexperienced workmen), is sure to result in a leaky roof. The mode of using them is very simple, as the adjustment is the same whichever way they are driven, and on flat iron as well as corrugated. These nails may be made by first moulding a flat head and then cupping them by means of stamping or other processes, or moulding as aforesaid.



What we claim as the special novelty in our wire roofing nail is—

First—The cup or hollow head, marked A (by whatever process it may be formed), which causes the self-adjustment of the nail and saves the time of dressing down the heads or washers.

Second—The cone round the neck inside the cup or hollow head, as shown at B, which, when driven, fills in the indent made in the iron by the point of the nail.

In witness whereof, we, the said Alfred Robb and William Stokes, have hereto set our hands and seals, this sixth day of October, one thousand eight hundred and eighty-four.

ALFRED ROBB.

WILLIAM STOKES.

(By their Attorney, EDWD. WATERS.)

Witness—

W. S. BAYSTON,

Patent Law Clerk, Melbourne.

This is the specification referred to in the annexed Letters of Registration granted to Alfred Robb and William Stokes, the 1st day of December, A.D. 1884.

AUGUSTUS LOFTUS.

REPORT.

Sir,

The application of Messrs. Robb and Stokes for Letters of Registration for an invention entitled "The Cup-headed Self-adjusting Wire Roofing Nail, requiring no washer," having been referred to us, we have examined the specification and drawing accompanying the same, and have now the honor to report that we see no objection to the issue of Letters of Registration as prayed for.

We have, &c.,

JAMES BARNET.

EDMUND FOSBERY.

The Under Secretary of Justice.



A.D. 1884, 3rd December. No. 1538.

IMPROVEMENTS IN DOUBLE-ACTION PUMPS.

LETTERS OF REGISTRATION to Charles Frederick Amos and Henry Wilson Ringrose Smith, for Improvements in Double-action Pumps.

[Registered on the 3rd day of December, 1884, in pursuance of the Act 16 Vic. No. 24.]

BY HIS EXCELLENCY THE RIGHT HONORABLE SIR AUGUSTUS WILLIAM FREDERICK SPENCER LOFTUS (commonly called LORD AUGUSTUS LOFTUS), Knight Grand Cross of the Most Honorable Order of the Bath, a Member of Her Majesty's Most Honorable Privy Council, Governor and Commander-in-Chief of the Colony of New South Wales and its Dependencies.

TO ALL TO WHOM THESE PRESENTS SHALL COME, greeting :

WHEREAS CHARLES FREDERICK AMOS and HENRY WILSON RINGROSE SMITH, both of Kingston-upon-Hull, in the county of York, England, engineers, have by their Petition humbly represented to me that they are the authors or designers of a certain invention or improvement in manufactures, that is to say, of an invention entitled "Improvements in Double-action Pumps," which is more particularly described in the specification and the sheet of drawings which are hereunto annexed ; and that they the said Petitioners have deposited with the Honorable the Treasurer of the said Colony of New South Wales the sum of Twenty Pounds sterling, for defraying the expense of granting these Letters of Registration, as required by the Act of Council, sixteenth Victoria, number twenty-four ; and hath humbly prayed that I would be pleased to grant Letters of Registration, whereby the exclusive enjoyment and advantage of the said invention or improvement might be secured to them for a period of fourteen years : And I, being willing to give encouragement to all inventions and improvements in the arts or manufactures which may be for the public good, and having received a report favourable to the prayer of the said Petition, from competent persons appointed by me to examine and consider the matters stated therein and to report thereon for my information, am pleased, with the advice of the Executive Council, and in exercise of the power and authority given to me by the said Act of Council, to grant, and do by these Letters of Registration grant unto the said Charles Frederick Amos and Henry Wilson Ringrose Smith, their executors, administrators, and assigns, the exclusive enjoyment and advantage of the said invention or improvement, for and during the term of fourteen years from the date hereof ; to have, hold, and exercise unto the said Charles Frederick Amos and Henry Wilson Ringrose Smith, their executors, administrators, and assigns, the exclusive enjoyment and advantage thereof, for and during and unto the full end and term of fourteen years from the date of these presents next and immediately ensuing, and fully to be complete and ended : Provided always, that if the said Charles Frederick Amos and Henry Wilson Ringrose Smith shall not, within three days after the granting of these Letters of Registration, register the same in the proper office in the Supreme Court, at Sydney, in the said Colony of New South Wales, then these Letters of Registration, and all advantages whatsoever hereby granted, shall cease and become void.

In witness whereof, I have hereunto set my sign manual, and have caused the present Letters of Registration to be sealed with the seal of the said Colony of New South Wales, at Government House, Sydney, in New South Wales, this third day of December, in the year of our Lord one thousand eight hundred and eighty-four.

[L.S.]

AUGUSTUS LOFTUS.

Improvements in Double-action Pumps.

SPECIFICATION of CHARLES FREDERICK AMOS and HENRY WILSON RINGROSE SMITH, both of Kingston-upon-Hull, in the County of York, England, engineers, for an invention entitled "Improvements in Double-action Pumps."

THE object of this invention is so to construct double-action pumps as to render access to the valves easy, without necessitating the displacement or disarrangement of the pump-gear. To this end we so arrange the valves in the pump cylinder or cylinders that they shall open outwards or towards doors or covers which close the ends of the cylinders. Thus, when the valves require renewing, or when any obstruction occurs to interfere with their efficient action, by simply removing the doors or cover the interior of the pump may be brought to view; thus any defect or obstruction may be readily removed.

In carrying out the invention we may use one cylinder, divided into two by a transverse partition to receive the valved pistons, or two cylinders may be used set parallel to each other.

In the accompanying drawing both these plans for carrying out our invention are illustrated.

Fig. 1 is a longitudinal sectional elevation of a double-action pump with its cylinders set in line; fig. 2 is a sectional plan of the same taken in the line 1 2 of fig. 1; and fig. 3 is a vertical section taken in the line 3 4 of fig. 1.

This form of pump is intended to be bolted to a wall, and for this purpose it is cast with lugs to receive the supporting bolts.

The pump is made preferably of a single casting A, the cylindrical ends A¹, A², for receiving the pistons BB, being closed by swing covers or doors *a*, and the central portion A³ having an open side to admit the gear within the pump. This open side is closed by a plate or cover *a'*, which carries a stuffing box for receiving the spindle C of the pump. The inner end of this crank spindle works in a socket provided to receive it on the inner face of the chamber A³. Pendant from the spindle C is an arm C¹, which enters a slot formed near the middle of the rod B¹, which carries at its opposite ends the pistons BB. This arm C¹ serves as the spindle C is rocked to impart a reciprocating motion to the rod and its pistons. These pistons are made hollow, and are fitted with clack valves, which open outwards. The inner end of the pump cylinder A² is closed by a partition *a''*, which forms part of the casting A, and is fitted with a stuffing box, through which the piston-rod B¹ slides. The inner end of the other cylinder A¹ is open to the central chamber A³, in which the spindle C and arm C¹ are situate, and in communication with this central chamber is the feed passage D¹, which thus brings the discharging end of the one cylinder into communication with the receiving end of the other cylinder. D² is the discharge passage from the cylinder A², it being for convenience led back from the end to the centre of the casting A. The spindle C is fitted externally with a hand lever C², by the working of which the pump is kept in action.

As a reciprocating motion is imparted to the pistons, water or other liquid entering by the passage D will flow into the central chamber, thence through the piston of the cylinder A¹, and by the passage D¹ to the back of the piston in the cylinder A². The water passed through the piston of this cylinder will at the next forward stroke of the piston be forced up the passage D² and discharged from the pump.

It will now be understood that if the pump leathers require renewing, or if the pump has become clogged, access may be obtained to the interior of the pump by simply uncovering the ends of the cylinders, which may be readily done by unshipping the eye bolt, fig. 1, and turning the cover on the remaining bolt, which will act as a pivot-pin, and thus by our arrangement all necessity for unshipping the pump gear is avoided.

Fig. 4 is a sectional elevation of a pump with its cylinders set parallel to each other, and arranged to secure the advantages of renewing the pump leathers, and removing any obstruction to the free action of the pump by the simple uncovering of the cylinder ends.

As similar letters of reference for like parts are used in this and the abovementioned figures, no detailed description of this pump will be required.

The piston-rods, it will be seen, work through stuffing-boxes in the ends of their respective cylinders, and are connected by links to a beam B², which receives a rocking motion from a connecting-rod B³, leading from gearing which may be actuated by manual or steam power.

The covers *a* of the cylinders will in this arrangement be held in place by a series of bolts and nuts, the removal of which will be required to give access to the interior of the pump.

Having now set forth the nature of our invention of "Improvements in Double-action Pumps," and explained the manner of carrying the same into effect, we wish it to be understood that we claim:—

The arrangement of double-action pumps, as above described, whereby access is gained to the valves without displacing or disarranging the pump-gear.

In witness whereof, we, the said Charles Frederick Amos and Henry Wilson Ringrose Smith, have hereunto set our hands and seals, this _____ day of _____, in the year of our Lord one thousand eight hundred and eighty-four.

CHAS. F. AMOS.

H. W. RINGROSE SMITH.

This is the specification referred to in the annexed Letters of Registration granted to Charles Frederick Amos and Henry Wilson Ringrose Smith, the third day of December, A.D. 1884.

AUGUSTUS LOFTUS.

REPORT.

Sir,

Sydney, 22 October, 1884.

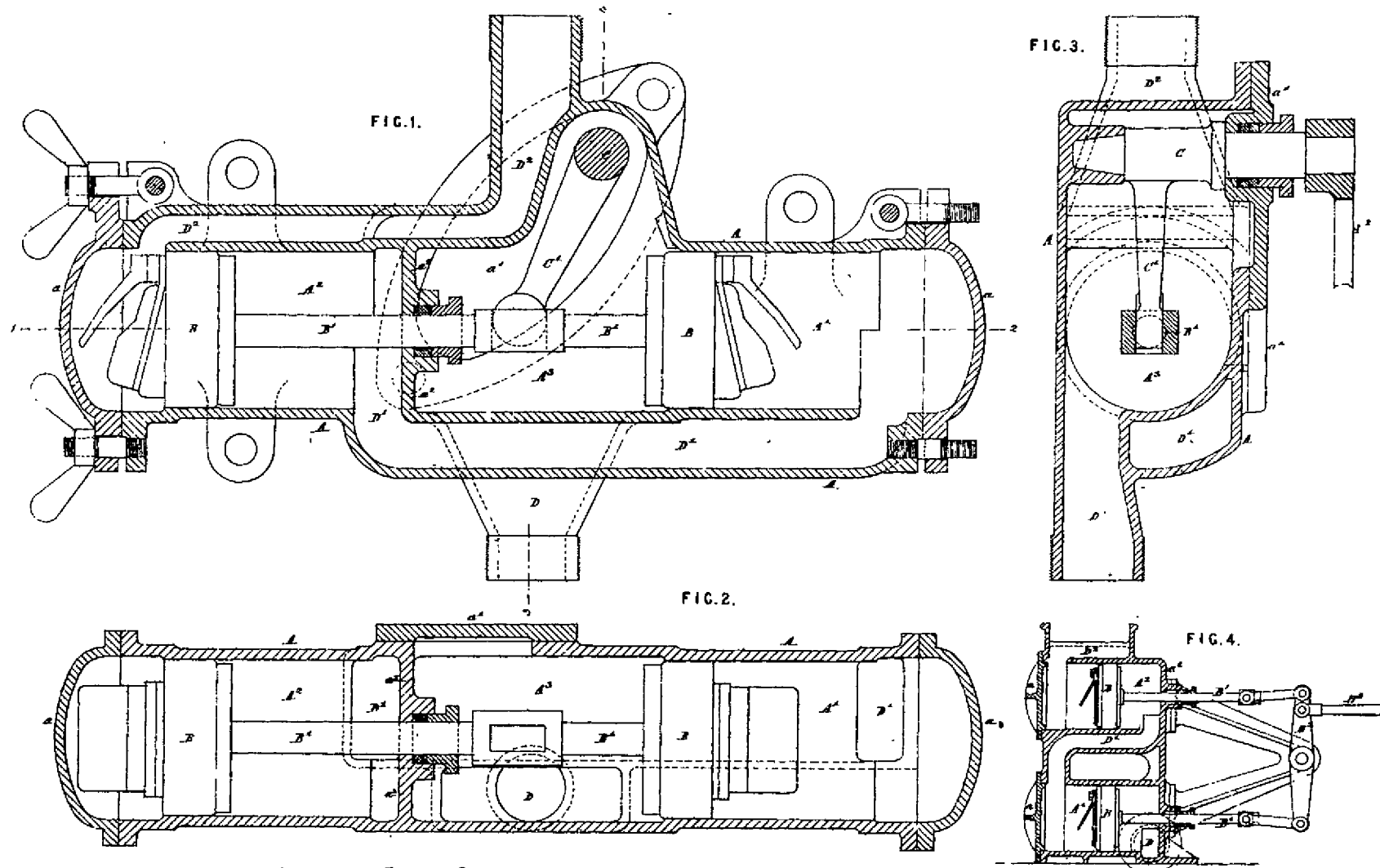
We do ourselves the honor to report, in reply to your blank cover, 15th instant, transmitting Messrs. C. F. Amos and H. W. R. Smith's petition for the registration of an invention entitled "Improvements in Double-action Pumps," that we are of opinion the prayer of the Petitioners may be granted in terms of their specification, drawings, and claim.

We have, &c.,

GOTHER K. MANN.

EDMUND FOSBERY.

The Under Secretary of Justice.



*This is the Sheet of Drawings referred to in the annexed Letters of Registration, granted to Charles Frederick Amos, and Henry Wilson Ringrose Smith, the third day of December, A. D., 1884.
Augustus Loftus.*



A.D. 1884, 13th December. No. 1539.

IMPROVEMENTS IN OR APPLICABLE TO SIMPLE AND AUTOMATIC VACUUM BRAKES.

LETTERS OF REGISTRATION to James Gresham, for Improvements in or applicable to Simple and Automatic Vacuum Brakes.

[Registered on the 15th day of December, 1884, in pursuance of the Act 16 Vic. No. 24.]

BY HIS EXCELLENCY THE RIGHT HONORABLE SIR AUGUSTUS WILLIAM FREDERICK SPENCER LOFTUS (commonly called LORD AUGUSTUS LOFTUS), Knight Grand Cross of the Most Honorable Order of the Bath, a Member of Her Majesty's Most Honorable Privy Council, Governor and Commander-in-Chief of the Colony of New South Wales and its Dependencies.

TO ALL TO WHOM THESE PRESENTS SHALL COME, greeting :

WHEREAS JAMES GRESHAM, of the firm of Gresham & Craven, of Craven Iron Works, Salford, in the county of Lancaster, England, engineers and machinists, hath by his Petition humbly represented to me that he is the author or designer of a certain invention or improvement in manufactures, that is to say, of an invention entitled "Improvements in or Applicable to Simple and Automatic Vacuum Brakes," which is more particularly described in the specification marked A, and the five sheets of drawings marked B, C, D, E, and F, which are hereunto annexed; and that he, the said Petitioner, hath deposited with the Honorable the Treasurer of the said Colony of New South Wales the sum of Twenty Pounds sterling, for defraying the expense of granting these Letters of Registration, as required by the Act of Council, sixteenth Victoria, number twenty-four; and hath humbly prayed that I would be pleased to grant Letters of Registration, whereby the exclusive enjoyment and advantage of the said invention or improvement might be secured to him for a period of fourteen years: And I, being willing to give encouragement to all inventions and improvements in the arts or manufactures which may be for the public good, and having received a report favourable to the prayer of the said Petition, from competent persons appointed by me to examine and consider the matters stated therein and to report thereon for my information, am pleased, with the advice of the Executive Council, and in exercise of the power and authority given to me by the said Act of Council, to grant, and do by these Letters of Registration grant unto the said James Gresham, his executors, administrators, and assigns, the exclusive enjoyment and advantage of the said invention or improvement, for and during the term of fourteen years from the date hereof; to have, hold, and exercise unto the said James Gresham, his executors, administrators, and assigns, the exclusive enjoyment and advantage thereof, for and during and unto the full end and term of fourteen years from the date of these presents next and immediately ensuing, and fully to be complete and ended: Provided always, that if the said James Gresham shall not, within three days after the granting of these Letters of Registration, register the same in the proper office in the Supreme Court, at Sydney, in the said Colony of New South Wales, then these Letters of Registration, and all advantages whatsoever hereby granted, shall cease and become void.

In witness whereof, I have hereunto set my sign manual, and have caused the present Letters of Registration to be sealed with the seal of the said Colony of New South Wales, at Government House, Sydney, in New South Wales, this thirteenth day of December, in the year of our Lord one thousand eight hundred and eighty-four.

[L.S.]

AUGUSTUS LOFTUS.

Improvements in or applicable to Simple and Automatic Vacuum Brakes.

A.

SPECIFICATION of JAMES GRESHAM, of the firm of Gresham & Craven, of Craven Iron Works, Salford, in the county of Lancaster, England, for an invention of "Improvements in or applicable to Simple and Automatic Vacuum Brakes."

FIRSTLY, my invention relates to and consists in an improved combination of ejector apparatus for producing the partial vacuum (hereinafter called the vacuum) required for actuating vacuum brakes for railway trains, with mechanism for bringing the ejectors into and out of action, and for admitting air to and excluding it from the pipes communicating with diaphragms, pistons, or other apparatus (hereinafter referred to) giving movement to the mechanism which applies and withdraws the brakes from the wheels of the train. The object of this part of my invention is to combine all the apparatus for actuating and controlling the brakes in one connected apparatus operated by one handle.

My improved mechanism is applicable for either simple or automatic vacuum brakes. By simple vacuum brakes (hereinafter referred to) is meant those in which the vacuum is formed in the pipe, passing along the train commonly termed the "train pipe," when the brakes are to be applied to, and in which the vacuum is destroyed in the train pipe, when the brakes are to be withdrawn from the wheels of the train, and by automatic vacuum brakes (hereinafter referred to) is meant those in which a vacuum is maintained in the train pipe when the brakes are withdrawn from the wheels, and in which the brakes are applied when such vacuum is destroyed by the severance of the train or otherwise, or by admitting air into the train pipe when the brakes are to be applied.

For both the simple and automatic brakes a small ejector is used within a large ejector, but the small ejector in each case is proportioned in capacity to the work it has to perform.

For simple vacuum brakes the large ejector is for forming the vacuum to apply the brakes, and the small ejector is in constant use for test purposes or as a "tell-tale" to show that the simple vacuum brakes are in order, and this small ejector only requires to be of a capacity to produce a partial vacuum equal to a few ounces per square inch. The manner in which this small ejector acts as a tell-tale will be hereinafter described. For automatic brakes the large ejector is for quickly forming a vacuum in the train-pipe, and the small ejector is in constant use (except as hereinafter explained) for maintaining the vacuum when formed by the large or the joint action of both ejectors. The small ejector has power enough to form the vacuum alone, as well as maintain it, but not to do it quickly enough.

Small and large ejectors are used, because there would be a waste of steam if the ejectors were not proportioned in capacity to the steam to be used and the work to be done.

Fig. 1 is a longitudinal section in a line 1-2, fig. 3, with the disc valve and handle shown in long and short dotted line.

Fig. 2 is a longitudinal section on the line 3-4, fig. 3, but showing an outside view of the internal parts of the ejector, and the handle for operating the disc valve (cut away by the section) is shown in peculiar dotted line.

Fig. 3 is a section on the line A-B, fig. 1, and fig. 4 a section on the line C-D-E, fig. 1.

Fig. 5 is a longitudinal section on an enlarged scale of an internal part of the ejectors which screws into the main casing.

Fig. 6 is a longitudinal section of internal parts that screw into the part shown by fig. 5.

Fig. 7 is a half section on the line F-G, fig. 5, the other half of the section being a duplicate on the opposite side.

Fig. 8 is a longitudinal section of the cone nozzle that screws into the part shown by fig. 5.

Fig. 9 is a section on the line H-I, fig. 2, looking towards the seating of the disc valve of the apparatus when used for automatic vacuum brakes, and fig. 10 is a similar view when used for simple vacuum brakes.

Fig. 11 is the face view of the disc valve, and fig. 12 the face view of the disc valve seating for automatic brakes.

Fig. 13 is the face view of the disc valve, and fig. 14 the face view of the disc valve seating for the simple vacuum brakes.

a is the main external casing, which may be secured by bolts passing through a flange a^1 to any convenient part of the locomotive, a pipe P being connected by a union coupling with the casing (a) to convey the steam and air to the smoke-box or blast-pipe of the locomotive.

In some cases the casing is or may be secured to the fire-box end plate w of the locomotive boiler, part of the casing passing inside the boiler, and the pipe P from it thus goes through the boiler to the smoke-box or blast-pipe. This arrangement, with a long pipe between the ejector and the smoke-box, deadens the noise caused by the ejectors when working.

The part a^1 is the contracting cone where the steam and air combine, a^2 is a parallel part, and a^3 is the expanding cone of the large ejector.

The casing has a branch a^4 , to which the steam supply pipe q is connected by a union joint. The casing has also another branch a^5 , to which a pipe r communicating with the train pipe is connected.

This branch a^5 has a seating formed in it for a valve e faced with leather or India-rubber, secured to the valve by a screw, this valve being hinged or jointed on a pin e^1 carried in the two arms of a lid e^2 , which is secured to and made to cover a hole air-tight in the casing through which the valve is inserted (see figs. 1, 3, and 4).

In the cover a screw-tapped hole e^3 is made, in which the end of a small pipe is screwed, and the outlet end of this small pipe is in any convenient position, and has a small hole constantly open to allow any moisture formed in the ejectors to drain away.

The valve e acts to prevent air passing from the ejectors to the train pipe, but allows air to pass from the train pipe to the large ejector.

From the chamber of the valve e there is a passage leading to annular cavity t formed round the part c and between it and the interior of the casing.

The part c , shown by fig. 5, is mainly the casing in which the cones for the small ejector are formed, but on the exterior of the part c there is a cylindrical part c^1 connected with the part c by hollow radiating ribs (see fig. 7), leaving spaces between them by which the air can pass from the cavity t to the cone b , which is screwed into the cylindrical part c^1 , as shown best in fig. 1. This

Improvements in or applicable to Simple and Automatic Vacuum Brakes.

This cone *b* has two flats formed upon it on opposite sides, seen best in fig. 3, for a screw key to screw it in, and unscrew it from the part *c*.

There is an annular space left between the exterior of the cone *b* and the interior of the casing *a* for steam to pass which comes from the cavity *a* formed in the casing round the cone *b*.

This cavity *a* communicates with ports in a disc valve seating (see fig. 3) formed in the casing, and the space outside this disc valve *f* communicates with the branch for the steam pipe *a*, as seen best in fig. 3.

The disc valve *f* is partly sunk and fitted in and ground to the seating so as to partly rotate, and there are two ports in the seating and two corresponding ports in the disc valve (hereinafter referred to), so that when the latter is moved to one position the ports come opposite and steam can pass, and when moved into another position the ports in the seating are covered, and the steam is shut off from the large ejector. The screw plug *f*, fig. 3, is for oiling the valve *f*.

Into the interior of the part *c* the central part *d* is screwed for the small ejector. This part *d* is tubular closed at one end and formed with a screw head, and it is prepared in its interior with a seating for a small cone valve *d* having ordinary guiding wings on both sides, and when the valve is in its place the cone nozzle *e* is screwed in, as shown.

When the part *d* is screwed in its place it fits air and steam tight where it comes in contact with the interior of the part *c*. There is space formed in the interior of the part *c* which forms an annular cavity *d* round the exterior of the part *d*, and small holes *d* are formed through the sides of the part *d* so as to allow air to pass from the cavity *d* on the exterior to the interior of the part *d* above the small valve *d*.

The internal annular cavity *d* communicates by small holes *e* with a groove *e* round the exterior of the part *c*, thus forming an annular cavity between it and the interior of the casing *a*, and this cavity communicates by a passage *i* with the valve seating for the air disc valve, as shown best in fig. 2, hereinafter further referred to.

The part *c*, where its exterior comes in contact with the interior of the casing *a*, fits air and steam tight, and there is an annular cavity *e* in the interior of the casing round the cylindrical part *c*, and there are holes *e* in the ribs connecting the cylindrical part *c* and the interior part to allow the steam to pass to a cavity *e* to supply steam to the exterior of the nozzle *e* for the small ejector which escapes through a small annular space left between the exterior of the nozzle and the interior of the part *c*.

The annular cavity *e* is connected by a passage with the steam branch *a* (see fig. 1), a seating being formed in the casing for a valve *h* that has a stem that can slide freely in a hole in the axis of a spindle *h* that screws into the casing, a packing gland being formed round the spindle *h* to keep it steam tight.

By means of a handle *h* on the end of the spindle *h* it can be screwed in or out. When screwed in, the valve *h* is shut and steam cannot pass, but when screwed outwards the steam can pass to the small ejector.

In ordinary working this valve *h* is constantly open to supply steam to the small ejector. The casing is formed with passages or cavities *a* covered by a disc having ports in it. This disc *i* has an inner central boss screwed on its exterior, which screws into a boss formed in the casing (see figs. 2 and 3), and when screwed tight an air and steam joint is formed between the disc *i* and casing.

The inner side of the disc *i* is formed with a cone seating for a spindle *f* with a cone upon it, and on the inner end of the spindle a flat part is formed to fit easily a slot in the disc valve *f* for steam.

A helical spring *f* is placed round the boss of the valve *f* and between it and the shoulder at the inner side or back of the cone on the spindle *f* to keep the steam disc valve *f* against its seating.

The spindle *f* passes through a boss in the disc seating *i*, which boss also acts as a packing gland, and the disc valve *f* has a cavity that fits on the exterior of the boss, and the boss of the disc valve *f* has a square hole to fit squares formed upon the outer end of the spindle *f*, and is secured by a screw, as shown (see figs. 2 and 3).

The disc valve *f* has a handle *g* by which it is oscillated along with the spindle *f*, which thus gives motion at the same time to the disc valve *f* for supplying to and shutting steam from the large ejector.

The handle *g* has a flat steel spring *g* secured to it by a screw, and the end of the spring has a pin *g* rivetted in it which passes through a hole in the handle *g*, the end of the pin being cone pointed, so that when the handle is moved from one extreme position to another the cone pointed pin *g* will enter or pass over, as required, a hole *i* in the face of the disc seating. The object of this arrangement is to enable the operator to feel when the handle *g* is in what is termed the running position, and to hold it in that position when required. There are also projections *i* and *i* in the disc seating, which limit the two extreme movements of the handle.

The disc valve *f* is formed by two discs connected at their edges with a cavity or space between them (see fig. 2), and through the inner disc there are port holes which correspond with ports in the disc seating, and there is also a cavity port in the disc. The outside disc of the disc valve is perforated with small holes *g* to admit air freely into the cavity between the two discs of the disc valve.

In fig. 9 the handle *g* (for automatic vacuum brakes) is shown in the running position *x*, that is in the position when the train is travelling and the brakes are not acting on the wheels. In this position of the handle the steam ports *f* in the disc valve for steam are not opposite the ports *a* in the casing, consequently no steam is passing to the large ejector. The three ports *g* in the disc valve *f* are not, when the handle *g* is in the position *x*, opposite the three ports *i* in the seating, which communicate with the cavity *a* in the casing which is in connection with the train pipe through the passage *a*, fig. 3, consequently no air is admitted to the train pipe.

The cavity port *g* corresponds and communicates with one of the ports *i* and with the ports *i* and *i* in the disc seating *i*, one of which *i* communicates with the passage *i* leading to the small ejector, the other *i* with a passage *a*, to which a pipe is coupled, leading to the upper side of the sacks or cylinders on the locomotive and tender to keep those brakes applied if those of the train should leak off.

In the position *x*, in which the handle *g* is shown, the cavity port *g* is in communication with the port *i* and the nearest of the ports *i*, but not with the port *i*, therefore the small ejector is then acting to draw air from the train pipe through the passage *a*, cavity port *g*, port *i*, and passage *i*.

In the position *x* of the handle *g* the port *i* is closed.

When

Improvements in or applicable to Simple and Automatic Vacuum Brakes.

When the handle g^1 is in the position x^2 to apply the brakes, the steam ports f^3 are shut, the ports g^4 and i^2 to admit air into the train pipe are open, the communication between the cavity port g^5 and one of the ports i^2 is closed, but it is open to the port i^1 , communicating with the top side of the sack or cylinder of the engine or tender brakes, the small ejector thus acting to keep those brakes against the wheels of the engine and tender. When the handle g^1 is in the position x^1 to take the brakes off quickly, the air ports g^4 and i^2 are closed, and the steam ports f^3 and a^2 to the large ejector are open, and both the large and small ejector are then acting together to take off the brakes from the wheels, the port i^1 being then closed, and the cavity port g^5 is then in communication with one of the ports i^2 .

The cavity port g^5 is in every position of the handle g^1 in communication with the small ejector through the port i^1 , so that it is either exhausting air from the train pipe or from the upper side of the sacks or cylinders for the engine or tender. The same handle g^1 , disc valves g and f , and arrangement of ports and passages, which are used for automatic brakes, will also answer for simple vacuum brakes, the passage a^{10} being closed and the handle g^1 moved in the reverse directions for applying and removing the brakes; but when the apparatus is intended to be used for actuating and controlling simple vacuum brakes only, the ports are more simple when arranged, as shown in figs. 10, 13, and 14, as the cavity port g^5 , and connected ports and passages are not then required. In the running position x of the handle g^1 , fig. 10, the small ejector for test or tell-tale purposes, which is constantly working being supplied by steam by the valve h^2 , the air ports g^4 and i^2 are closed, and there is only a small partial test vacuum formed in the train pipe, consequently the brakes are all withdrawn from the wheels of the train. When the handle (fig. 10) is in the position x^2 to apply the brakes, the air ports g^4 and i^2 are closed, and the steam ports f^3 and a^2 to the large ejector are open and a strong vacuum is formed in the train pipes to apply the brakes.

When the handle is in the position x^1 (fig. 10) to take off the brakes, the steam ports f^3 and a^2 to the large ejector are shut, and the air ports g^4 and i^2 are open to admit air freely to take off the brakes.

For the last described arrangement the passage i^2 is dispensed with, and the cavity c^5 is made to communicate directly with the cavity a^9 .

Secondly, my invention relates to the brake arrangements and apparatus for simple vacuum brakes and to a tell-tale gauge and alarm for showing a word or signal or sounding a bell or gong, or both showing a word or signal and sounding a gong or bell when the vacuum apparatus of a train is not in order.

Fig. 15 is a sectional elevation showing part of the frames of two railway vehicles and brake apparatus; a the framing; b the train pipe, which passes from end to end of the train of vehicles having the apparatus applied; the pipes b , secured to the carriage, are metal pipes, and at each end of the vehicle a length of flexible tubing b^1 is joined up to the metal pipe b , and the end of the flexible tube b has a coupling b^2 , which is of such size and construction as to couple with any other similar coupling.

These couplings are well known.

When the couplings of the train pipe of two adjoining vehicles are not connected they are coupled with a dummy block or coupling b^3 attached to the vehicle, as shown in dotted line b^3 , this closes the end of the train pipe to the admission of air, and also keeps the end of the flexible tube from swinging about when the vehicle is in motion.

The partial vacuum (hereinafter called the vacuum) formed in the train pipe causes pressure of the external atmosphere to press and helps to retain the couplings together or upon their dummy blocks or couplings b^3 .

The train pipe b is a continuation from the apparatus on the locomotive described under the first head of my invention, when such apparatus is arranged for actuating simple vacuum brakes. In each vehicle, where the brakes are to be operated, there is a cylinder constructed in two parts with both ends closed when put together. The lower part of this cylinder c has trunnions c^2 , which are carried in bearings on the framing of the carriage.

The upper part of the cylinder c^1 is turned to fit the lower part c to make a joint, and the two parts are or may be secured together by bolts passing through lugs.

The upper part of the cylinder c^1 has a short tube connected by a flexible tube c^3 with a branch from the train pipe b , this branch ascending from the train pipe, so that moisture from the latter will fall back and not be liable to enter the cylinder. In the cylinder c there is a piston d , and the space between it and the cylinder is made tight by a rolling India-rubber packing ring d^1 .

The piston rod d^2 passes through a hole in the lower end of the cylinder c , and is jointed with an arm e from a shaft or fulcrum e^1 in suitable bearings on the vehicle. This shaft has an arm e^2 to which a cross-piece e^3 is jointed, to the ends of which rods e^4 are jointed, which are connected with the levers and rods of the brake-blocks, which are to act upon the wheels of the vehicle.

Thus arranged, the cylinder c can oscillate on its trunnions to suit the arc of the lever or arm e , to which the piston rod is connected. There are small holes c^4 in the lower end of the cylinder to allow air to pass to and from the under side of the piston.

When the brakes are to be applied a vacuum is formed by the ejector apparatus upon the engine forming the subject of the first part of my invention, and this causes air to be drawn from the train pipe b and from the cylinder c , at the upper side of the piston d , the atmosphere enters the cylinder c through the holes c^4 to the underside of the piston d and forces it upwards, and thus actuates the brakes, and when the vacuum is destroyed the atmosphere enters the train pipe and the cylinders through the pipe c^3 acting upon the upper side of the piston d , which is then in equilibrium, and the weight of the piston and connected parts causes it to fall and take off the brakes.

The tell-tale acts by the forming of a small partial vacuum in the train pipe by the small central ejector (hereinbefore described under the first head of my invention); such small vacuum has not power enough alone to apply the brakes, but it has power when all the train pipes are properly coupled, and there is no improper leakage to form such a partial vacuum, as will be indicated by the gauge and tell-tale or gong; but if this small vacuum cannot be made to show on the tell-tale it is known that the pipes are not properly coupled or that there is a leakage that would prevent the brakes from acting when required.

These tell-tales, gauges, or gongs, or both, are used on the locomotive and in the guard's van or other vehicles of a train if required.

Improvements in or applicable to Simple and Automatic Vacuum Brakes.

A tell-tale and vacuum gauge is shown on the left of fig. 15, and is supposed to be on the locomotive or tender. This gauge is connected by a branch pipe b' with the train pipe b .

It is drawn in the position to show the vacuum in the train pipe at zero and a plate in the face of the gauge with the word "wrong."

On the right of fig. 15, a gong and tell-tale is shown, which is, or may be, in the guard's van. A detached and enlarged section of the tell-tale gauge is shown by fig. 16; b' is a part of the branch pipe, communicating with a passage leading to the interior of a "Bourdon's" flat vacuum pressure tube f , which is arranged in the ordinary manner to act on an indicator hand coming to the face of the gauge (which is covered with glass), and pointing to an index in inches of mercury. From the passage leading to the "Bourdon's" tube f , there is a lateral passage leading to a cavity formed on one side by the casing g of the gauge, and on the other side by a flexible diaphragm g^1 , the centre of which is jointed with one end of a rod g^2 , the other end of which is jointed with an angle plate g^3 having two faces.

This angle plate has a fulcrum g^4 in the inside of the case, and it can oscillate to bring either one or the other of its two faces opposite a slot in the face of the gauge or tell-tale, and the angle plate g^3 is drawn (when the small vacuum is not operative) by a weak spring, so that that face upon which the word "wrong" is printed is opposite the slot, and as drawn in fig. 16 the parts are in the position exhibiting the word "wrong."

But when the small vacuum is properly operative upon the train pipe the diaphragm g^1 is drawn towards the back of the case, and the angle plate is oscillated to show the word "right."

Fig. 17 illustrates a combined tell-tale signal and bell or gong alarm.

The casing is formed in two parts.

One side of the lower part g forms the face of the tell-tale, and is glazed.

It has a slot g^2 in the face to show the word "wrong" and "right," the plate g^3 , having the two words in this case, being flat, carried on an arm g^5 , as hereinafter described. The upper part g^6 of the casing is screwed to the lower part by means of a flange and bolts, the edges of the diaphragm g^1 being first placed between the flanges as well as a dish or mid-feather g^7 , which forms a limit to the movement of the diaphragm and a guide to the stem g^2 passing from it.

The stem g^2 is secured to the diaphragm g^1 with a weight g^8 on its upper side, and the lower part of the stem g^2 has a square-threaded screw formed upon it that acts as a toothed rack, which gears with a small wheel h fast on a shaft h^1 carried in a bearing from the mid-feather dish g^7 .

This shaft h^1 has also a ratchet wheel fast upon it, into the teeth of which a pawl h^2 works that is jointed to the side of an escapement wheel h^3 , the teeth of which act upon the two arms of a pallet h^4 , having its oscillating fulcrum h^5 on a part from the mid-feather dish. The pallet has an arm and small hammer h^6 , which is arranged when oscillated to strike against a bell h^7 secured to the lower part of the casing g .

There is an arm g^5 from the rack or stem g^2 , which carries the plate g^3 with the words "wrong" and "right" upon it, and in the position in which the parts are shown in fig. 17 the word "wrong" is exhibited at the slot in the face of the tell-tale.

b' is a part of the branch pipe connecting with the train-pipe b .

When the small vacuum is properly operative upon the train pipe the diaphragm g^1 is lifted, as well as the weight g^8 and its rack stem, to its highest position, showing the word "right." In lifting, the rack rotates the wheel h in gear with it, and the ratchet wheel passes under the pawl h^2 on the pallet wheel h^3 , but when the small vacuum becomes inoperative the diaphragm g^1 , weight g^8 , and rack g^2 descend, and this rotates the shaft h^1 as the pawl enters the teeth of the ratchet, the pallet wheel h^3 is also rotated, and this causes the bell h^7 to be sounded during the descent of the weight and rack and the arm g^5 to bring the plate g^3 into the position to show the word "wrong."

In the guard's van there is or may be a handle b^5 actuating a valve on the branch from the train pipe b , the opening of which by the guard will render the small vacuum inoperative or ineffective, and will thus cause the tell-tale to show "wrong." By means of this handle b^5 the guard can thus signal to the driver and call his attention, and by a pre-arranged code information may be given from one to the other.

Thirdly, my invention relates to automatic vacuum brakes, and one modification will be illustrated by fig. 18. The train pipes and mode of coupling between the vehicles are the same as already explained for simple vacuum brakes, but in automatic brakes there is a constant vacuum kept in the train pipes and connected apparatus, while the brakes are not to be applied, and when they are to be applied the vacuum in the train pipes is destroyed by admitting the atmosphere, and this is done automatically when the parts of a train become severed.

j is an air-tight chamber or vessel secured to the vehicle. The train pipe is connected with this vessel, termed a vacuum chamber, by an ascending branch pipe j^1 passing through a valve arrangement, hereinafter described. The vacuum chamber j is also connected by a pipe j^2 with the upper side of a diaphragm cylinder c made in two parts secured together by flanges and screws, when the edges of the diaphragm d are secured between them.

The lower side of the cylinder c is also connected by a branch pipe j^3 with the train pipe b , the branch first ascending from the train pipe, as shown.

The diaphragm d comes between two discs, which are secured to a stem d^2 , the outer end of which is jointed with the arm e actuating the brakes. The stem d^2 can move freely through the hole in the bottom of the diaphragm cylinder, which is made air-tight by an elastic contracting and expanding sleeve d^3 secured by a clip to the boss upon the exterior of the bottom of the cylinder and to the joint part of the end of the stem, as shown.

The valve arrangement is shown on an enlarged scale by fig. 19; a longitudinal section k is a casing, one side connected by a pipe j^1 with the train pipe b , the other by a pipe j^2 with a vacuum chamber j .

There is an ascending passage from a pipe j^1 , and a descending passage to the vacuum chamber, and a seating for a ball valve k^1 is formed at the upper end of the descending passage, the ball valve being inserted through a hole in the top side of the casing, which is then closed by a screw plug k^2 , as shown.

The ball valve k^1 is free in a hole formed in a stem k^3 that is arranged to slide, one end being guided in a hole in the casing, the other end in a disc k^4 screwing into the casing, which acts to secure the edges

Improvements in or applicable to Simple and Automatic Vacuum Brakes.

edges of a diaphragm k^5 between the disc and casing, the central part of the diaphragm being connected with the sliding stem k^3 by a shoulder upon the latter and a screw nut upon it.

When a vacuum is formed in the train pipe b it withdraws the air from the underside of the brake diaphragm d , it also draws the air from the vacuum chamber j , and thus from the upper side of the brake diaphragm d , because the ball valve k^1 lifts to allow any air to pass, and as the brake diaphragm d is then in equilibrium it descends, and the brakes are taken off.

The vacuum also acts upon the small diaphragm k^5 upon the stem k^3 for the ball valve k^1 , and keeps the stem in the position shown in fig. 19.

When the vacuum in the train pipe is destroyed the atmosphere enters it and passes freely to the underside of the large diaphragm d for actuating the brakes, and as the ball valve k^1 prevents the entrance of the atmosphere into the vacuum chamber j the vacuum is maintained in the cylinder at the upper side of the large diaphragm d , and the pressure of the atmosphere thus acting on the underside applies the brakes.

When the carriages are detached the brakes are applied, and to release them by admitting air to the vacuum chamber j a T lever k^3 is jointed to the end of the ball valve stem k^3 , and then by a rod or wire connected with the end of this T lever, one rod or wire passing to one, the other to the other side of the vehicle, the lever may be oscillated one way or the other to bring one arm or the other of the T lever against the edge of the disc k^4 , which thus forms a fulcrum for drawing the stem k^3 outwards and the ball valve k^1 from its seating, thus allowing air to pass inwards.

Figs. 20 and 21 illustrate a modification coming under this head of my invention where the vacuum cylinder and chamber are combined together.

The brake cylinder may be considered a double one, the outer one c closed and forming the vacuum chamber, the inner cylinder c^1 (forming the piston cylinder) closed at its lower end and open to the vacuum chamber at its upper end into the cylinder c .

The cylinder c is arranged on trunnions c^2 so as to swivel to the arc of the lever e , with which the end of its piston rod d^2 is connected, as in the simple vacuum brakes described under the second head of my invention. The piston d is one with a rolling India-rubber packing ring d^1 between it and its cylinder c^1 .

The piston rod d^2 , from the piston d , passes through a gland packing of India-rubber composition. The valve casing k is attached to the underside of the cylinder c , and is connected with the train pipe by a flexible tube c^3 connected with a branch bend first ascending from the train pipe b .

Fig. 21 shows detached and on an enlarged scale the section of a valve casing k and passages. The ball valve k^1 , stem k^3 , and diaphragm k^5 for moving the ball valve from its seating, is substantially the same as that hereinbefore described and shown by fig. 19, and the stem may be actuated by a T lever in the same manner, but in the illustration, fig. 21, a straight lever k^6 is shown to be moved either way to actuate the stem in the lengthway of the vehicle.

The passages of the casing are modified, as one passage ascends above the ball valve and communicates with the cylinder c^1 on the underside of the piston d , and the passage from the ball valve first descends then goes horizontally, and then ascends and communicates with the cylinder or vacuum chamber c at the upper side of the piston d .

There is a hole in the side of the casing for the ball valve to be passed through, which hole is then secured by a screw plug k^2 . When a vacuum is formed in the train pipe the cylinder on both sides of the piston d is exhausted through the passages in the valve casing, but when air is admitted it is prevented from entering the upper side of the piston by the ball valve k^1 , but is free to pass up the passage above the ball valve to the underside of the piston d .

Fourthly, my invention relates to means by which brakes arranged to be worked automatically can be made to work as simple vacuum brakes, which is an advantage when trains are to be made up of vehicles having brakes worked on both systems, and the brakes can also be put out of action when not intended to be worked either by automatic or simple vacuum without obstructing the train pipe.

Fig. 22 is a side elevation; fig. 23 is a detached plan of the valve casing and mechanism; and fig. 24 is a detached sectional elevation of the cock and valve casing on an enlarged scale. The cylinder and connected parts and vacuum chamber are the same as that hereinbefore described and shown by fig. 18, except that the valve, mechanism, and passage or pipes are differently arranged. The cock and valve casing has junctions for four pipes, one c^3 for the short ascending branch from the train pipe, another j^1 for the pipe to the vacuum chamber j , another j^2 for the pipe to the cylinder c at the underside, and one j^3 for the cylinder at the upper side of the brake diaphragm d . The cock k^7 , which fits the casing, has three passages 1, 2, and 3, and in the position A, in which it is shown in fig. 24, the brake would work automatically, as it will be seen that the train pipe b is in that position of the cock open to communicate through the passage 1 with the cylinder c on the lower side, also with the cylinder through the ball valve k^1 and passages j^3 with the upper side of the diaphragm d , and with the vacuum chamber j through the passage 2 in the cock. When the cock is turned to the position C to work by simple vacuum, the vacuum chamber j is shut off from the train pipe, and the train pipe is open directly through the passage 1 in the plug to the cylinder at the upper side of the diaphragm d , and the cylinder c on the lower side of the diaphragm is in communication with the atmosphere through the chamber (3) in the cock and holes k^8 (see fig. 23) in one end of the plug k^7 , which is made hollow at that end. In the middle position B the cock k^7 shuts off all communication between itself and train pipe b , which is left free for communication between vehicles in its front and rear.

The cock k^7 can be turned by a handle from either side of the vehicle, the handle being arranged to be locked in any required position, the handle on each side being on the end of a shaft k^9 , one on each side in suitable bearings, the inner ends of the shafts each fitting on a square on the ends of the plug of the cock k^7 , as shown in fig. 23.

The ball valve k^1 is arranged to be actuated from either side of the carriage by wires k^4 connected with a T lever k^6 , as hereinbefore described and illustrated by fig. 23.

Having thus described my invention, what I claim as new, is—

- 1.—The combination of a small and large ejector with steam and air valves, the steam valve for the large ejector, and air valve for the train pipe, being both simultaneously actuated by the same handle, substantially as and for the purpose specified.

Improvements in or applicable to Simple and Automatic Vacuum Brakes.

- 2.—The combination of a small ejector within a large ejector, having steam valves with a disc valve for steam for the large ejector, and a disc valve for air to the train pipe, both actuated by the same handle, substantially as and for the purpose specified.
- 3.—In apparatus for actuating and controlling vacuum brakes, the combination of the following parts; a small ejector within a large ejector, a valve for controlling steam to the small ejector, a disc valve for controlling steam to the large ejector, a disc valve for controlling air to the train pipe, the disc valves for steam and air, being connected and actuated by the same handle, substantially as and for the purpose specified.
- 4.—In apparatus for actuating and controlling vacuum brakes, the combination of an ejector with a steam valve for the ejector and air valve for the train pipe, both simultaneously actuated by the same handle.
- 5.—In simple vacuum brakes, the construction, combination, and arrangement of brake cylinders, as hereinbefore described and illustrated by the drawings.
- 6.—The construction, combination, and arrangement of tell-tale gauges, substantially as hereinbefore described and illustrated by figs. 15 and 16 of the drawings.
- 7.—The construction, combination, and arrangement of tell-tale indicator and gong or bell alarm, substantially as hereinbefore described and illustrated by figs. 15 and 17 of the drawings.
- 8.—The combination and arrangement of simple vacuum brake cylinders, with indicator or tell-tale and gong arrangements, and arrangements for signalling by means of the handle, substantially as hereinbefore described and illustrated by figs. 15, 16, and 17 of the drawings.
- 9.—The construction, combination, and arrangement of automatic brake cylinders and connected valve pipes and mechanism, substantially as hereinbefore described and illustrated by figs. 18, 19, 20, and 21 of the drawings.
- 10.—The combination and arrangement of valve mechanism, substantially as hereinbefore described and illustrated by figs. 19 and 21 of the drawings.
- 11.—The combination and arrangement by which automatic vacuum brake mechanism can be made to work by automatic or simple vacuum or shut off from the train pipe, substantially as hereinbefore described and illustrated by figs. 22, 23, and 24 of the drawings.

In witness whereof, I have hereunto set my hand and seal, this twenty-sixth day of July, 1884.

JAMES GRESHAM.

Witness—

PETER J. LIVSEY,
24 and 25, Queen's Chambers,
5, Market-street, Manchester.

This is the specification marked A referred to in the annexed Letters of Registration granted to James Gresham, the thirteenth day of December, A.D. 1884.

AUGUSTUS LOFTUS.

REPORT.

Sir,

In reference to your B.C. memo. of 27th ultimo, forwarding petition from Mr. James Gresham for Letters of Registration for an invention entitled "Improvements in or applicable to Simple and Automatic Vacuum Brakes," we have the honor to inform you that, having examined the drawings and specification accompanying the petition, we are of opinion that the prayer of the Petitioner may be acceded to.

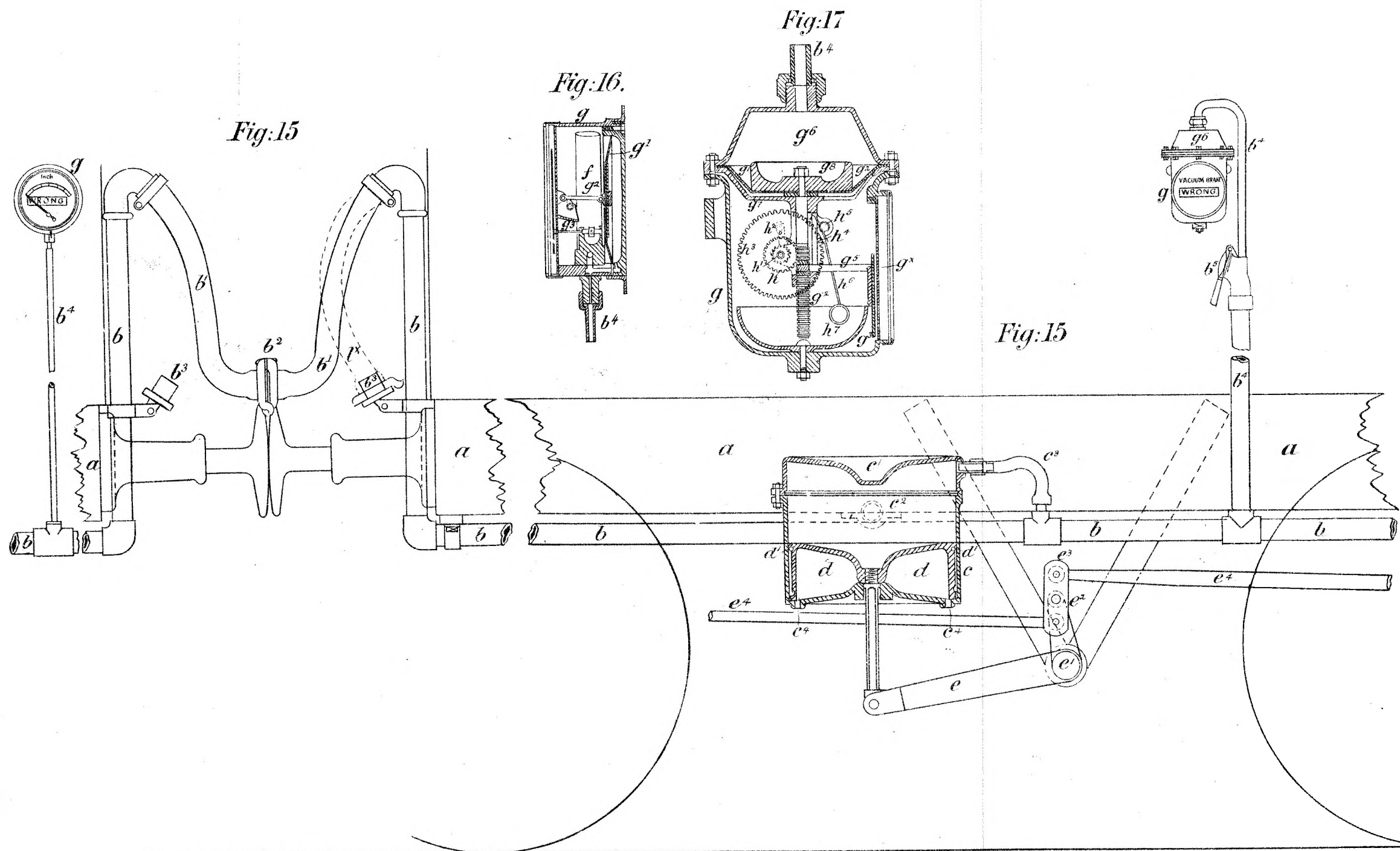
The Under Secretary of Justice.

Sydney, 30 October, 1884.

We have, &c.,

JOHN WHITTON.
E. O. MORIARTY.

[Drawings—five sheets.]



This is the Sheet of Drawings marked C, referred to in the annexed Letters of Registration, granted to James Gresham, the thirteenth day of December, A. D. 1884.

Augustus Loftus.

(Sig: 215)

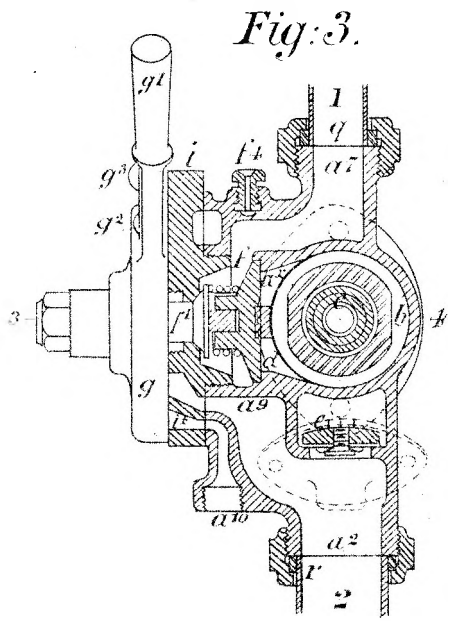


Fig. 3.

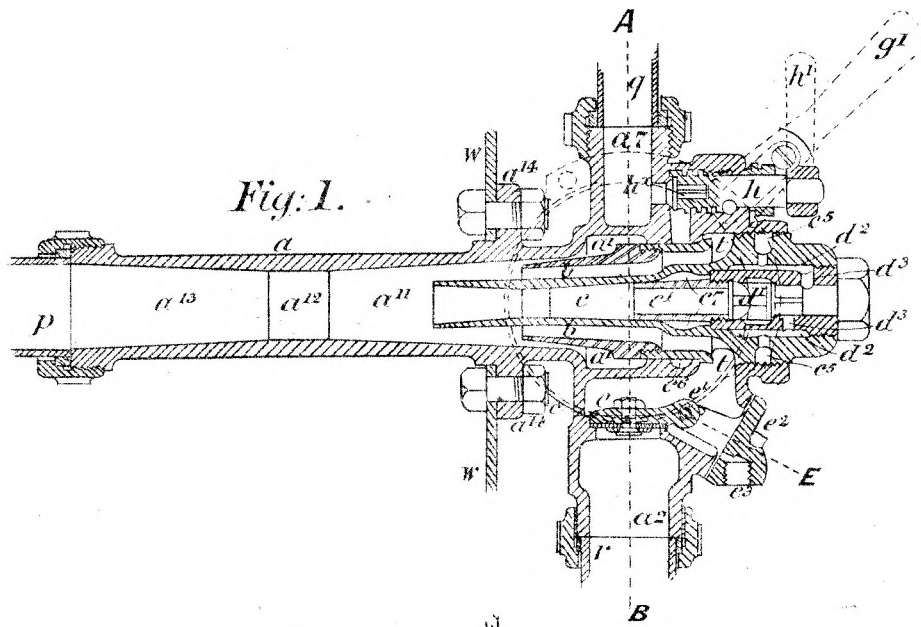


Fig. 1.

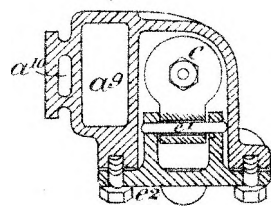


Fig. 4.

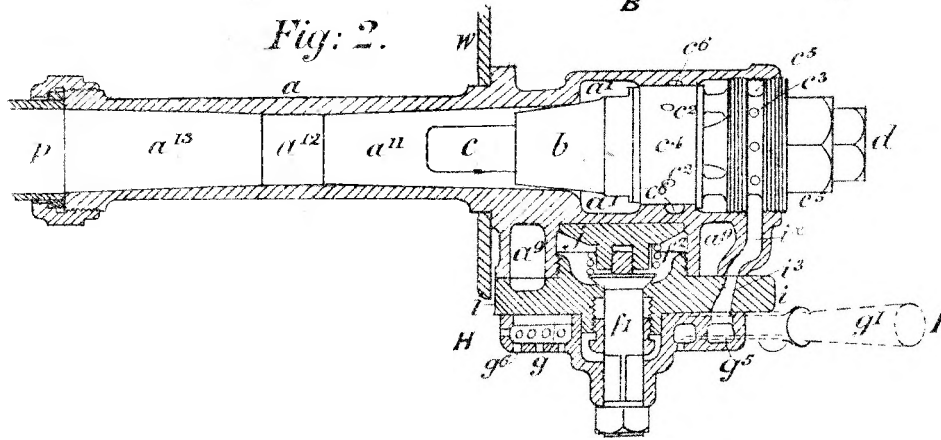


Fig. 2.

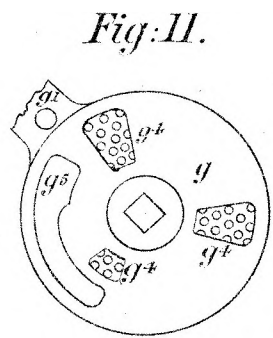


Fig. 11.

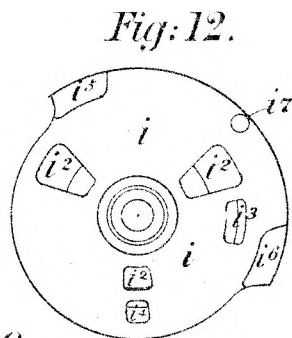


Fig. 12.

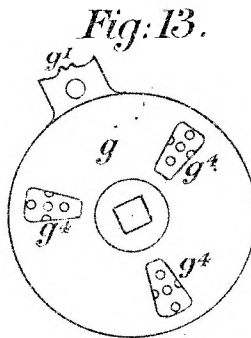


Fig. 13.

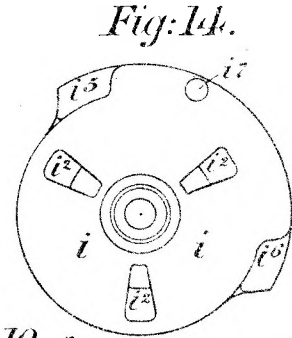


Fig. 14.

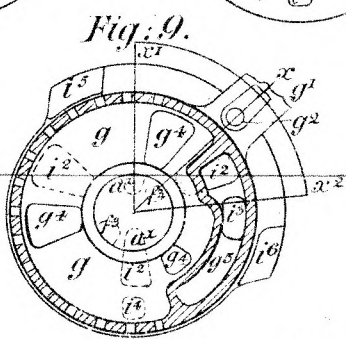


Fig. 9.

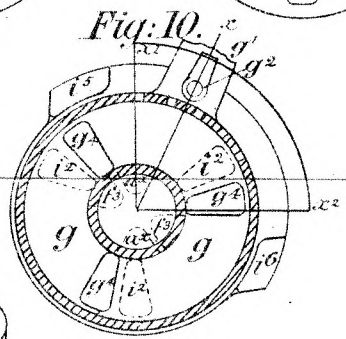


Fig. 10.

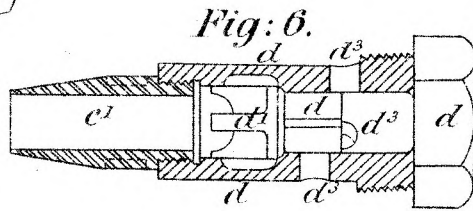


Fig. 6.

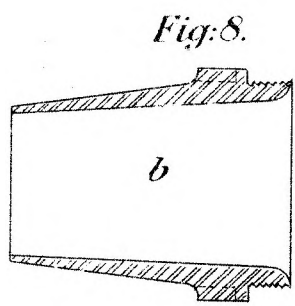


Fig. 8.

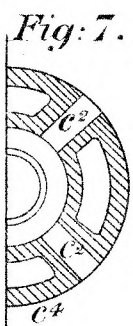


Fig. 7.

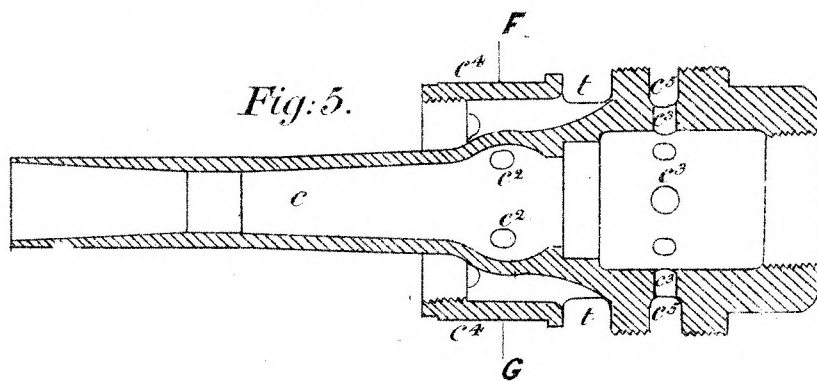


Fig. 5.

This is the Sheet of Drawings marked B, referred to in the annexed Letters of Registration, granted to James Gresham, the thirteenth day of December, A.D. 1884.
Augustus Loftus.

Gresham's Specification.

(5 Sheets)
Sheet 3.

Fig 19.

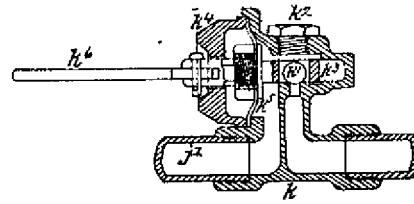
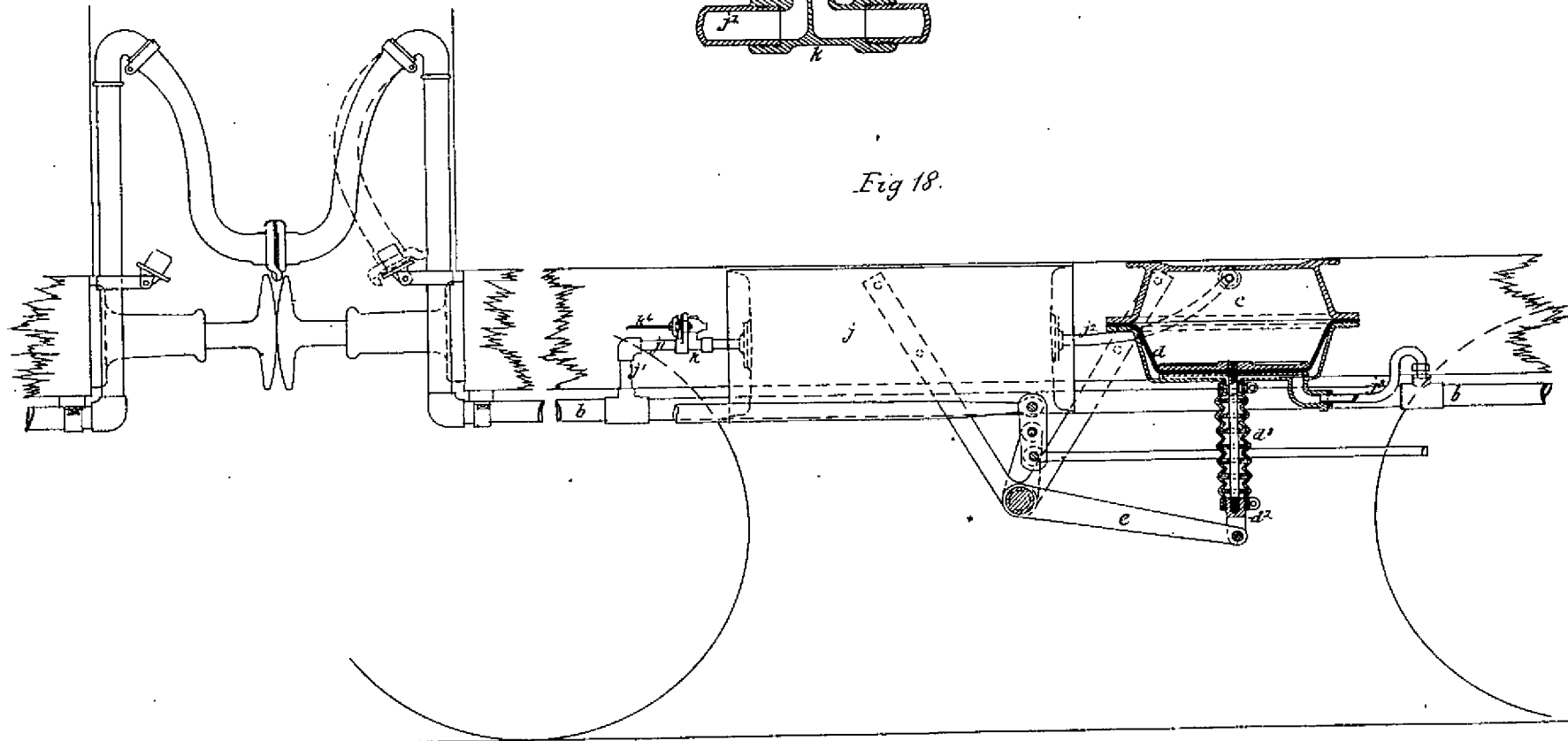


Fig 18.



This is the Sheet of Drawings marked D, referred to in the annexed
 Letters of Registration, granted to James Gresham, the thir-
 teenth day of December, A. D., 1884.

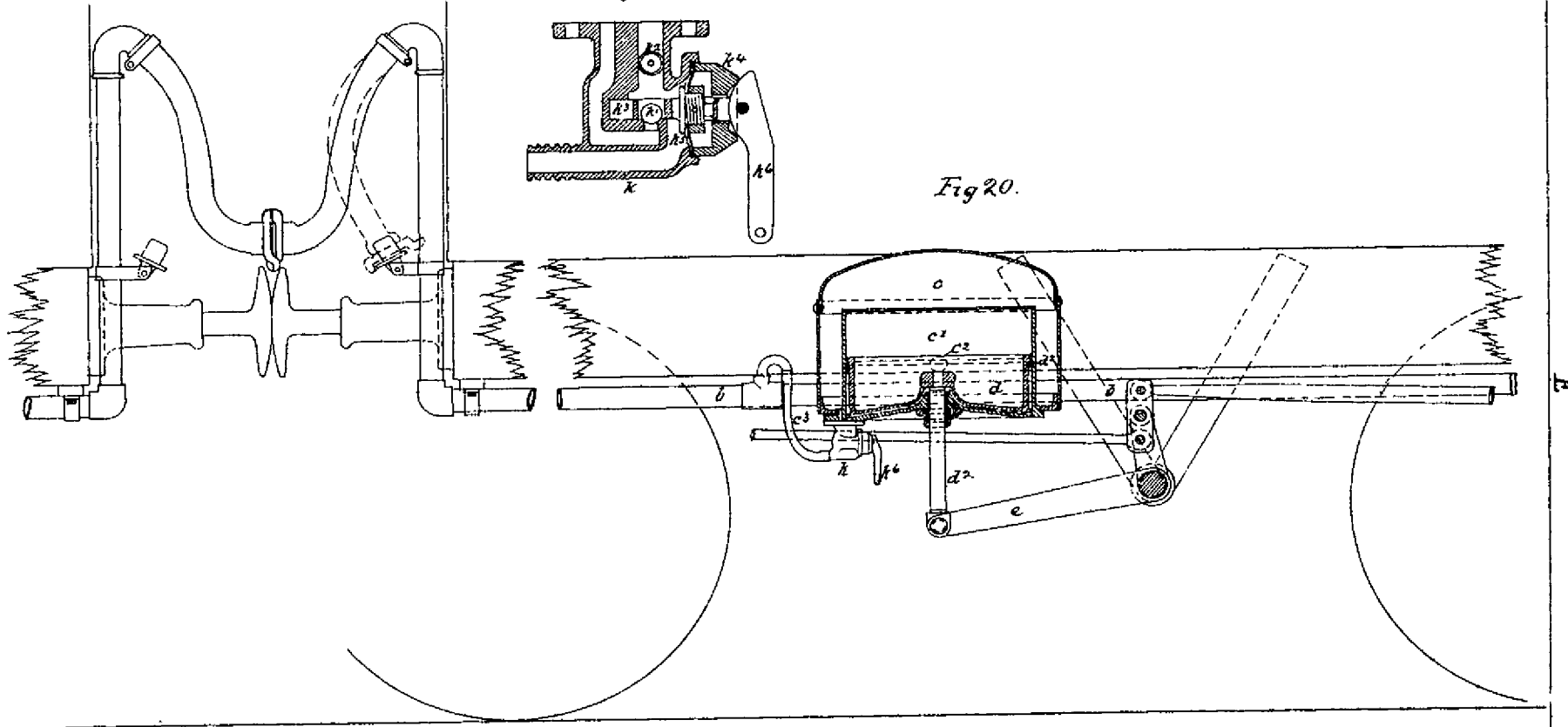
Augustus Loftus.

Gresham's Specification.

(5 Sheets)
Sheet 4.

Fig 20

Fig 21



This is the Sheet of Drawings marked E referred to in the
 annexed Letters of Registration, granted to James
 Gresham, the thirteenth day of December, A. D. 1884.
 Augustus Loftus.

(Sig. 245-)



A.D. 1884, 13th December. No. 1540.

AMALGAMATING APPARATUS.

LETTERS OF REGISTRATION to Adam Miller, for Amalgamating Apparatus.

[Registered on the 15th day of December, 1884, in pursuance of the Act 16 Vic. No. 24.]

BY HIS EXCELLENCY THE RIGHT HONORABLE SIR AUGUSTUS WILLIAM FREDERICK SPENCER LOFTUS (commonly called LORD AUGUSTUS LOFTUS), Knight Grand Cross of the Most Honorable Order of the Bath, a Member of Her Majesty's Most Honorable Privy Council, Governor and Commander-in-Chief of the Colony of New South Wales and its Dependencies.

TO ALL TO WHOM THESE PRESENTS SHALL COME, greeting :

WHEREAS ADAM MILLER, of Lime-street, in the city of London, England, engineer, hath by his Petition humbly represented to me that he is the author or designer of a certain invention or improvement in manufactures, that is to say, of an invention entitled "Amalgamating Apparatus," which is more particularly described in the specification, marked A, and the two sheets of drawings, marked B and C respectively, which are herewith annexed; and that he, the said Petitioner, hath deposited with the Honorable the Treasurer of the said Colony of New South Wales the sum of Twenty Pounds sterling, for defraying the expense of granting these Letters of Registration, as required by the Act of Council, sixteenth Victoria, number twenty-four; and hath humbly prayed that I would be pleased to grant Letters of Registration, whereby the exclusive enjoyment and advantage of the said invention or improvement might be secured to him for a period of fourteen years: And I, being willing to give encouragement to all inventions and improvements in the arts or manufactures which may be for the public good, and having received a report favourable to the prayer of the said Petition, from competent persons appointed by me to examine and consider the matters stated therein and to report thereon for my information, am pleased, with the advice of the Executive Council, and in exercise of the power and authority given to me by the said Act of Council, to grant, and do by these Letters of Registration grant unto the said Adam Miller, his executors, administrators, and assigns, the exclusive enjoyment and advantage of the said invention or improvement, for and during the term of fourteen years from the date hereof; to have, hold, and exercise unto the said Adam Miller, his executors, administrators, and assigns, the exclusive enjoyment and advantage thereof, for and during and unto the full end and term of fourteen years from the date of these presents next and immediately ensuing, and fully to be complete and ended: Provided always, that if the said Adam Miller shall not, within three days after the granting of these Letters of Registration, register the same in the proper office in the Supreme Court, at Sydney, in the said Colony of New South Wales, then these Letters of Registration, and all advantages whatsoever hereby granted, shall cease and become void.

In witness whereof, I have herewith set my sign manual, and have caused the present Letters of Registration to be sealed with the seal of the said Colony of New South Wales, at Government House, Sydney, in New South Wales, this thirteenth day of December, in the year of our Lord one thousand eight hundred and eighty-four.

[L.S.]

AUGUSTUS LOFTUS.

Amalgamating Apparatus.

A.

SPECIFICATION of ADAM MILLER, of Lime-street, in the city of London, England, engineer, for an invention entitled "Amalgamating Apparatus."

My invention relates to apparatus for extracting by amalgamation precious metals from pulverized ores, tailings, or other material containing them. The object which I have in view is to provide for thorough exposure of the metallic particles to the action of the amalgamating metal, and for conducting the operation in a continuous manner. I will describe my invention, referring to the accompanying drawings, which represent an apparatus suitable for amalgamating by mercury. When molten metal, such as molten lead or alloy, is used instead of mercury, the apparatus is generally similar to that shown, but it is placed over a fire or in a heated flue to keep the amalgamating metal in a fluid condition; and in order to prevent oxidation of the molten metal, I keep the apparatus above its level supplied with combustible gas, such as that obtained from a gas producer.

Referring to the drawings, fig. 1 is a vertical section of amalgamating apparatus according to my invention; fig. 2 is a sectional plan on X X; and fig. 3 is a plan on Y Y. The apparatus consists of a vessel in the form of an inverted siphon or U, having one limb A, preferably smaller in diameter than the other limb B. Both limbs are closed at the tops, and have mounted centrally within them vertical shafts C and D, carrying several sets of inclined or helical blades E and F. In the limb A there are several grids G; and at the bottom of the limb B there is also a grid H. In this limb also are fixed inclined or helical blades K to prevent the contents from acquiring rotation from the movement of the blades F. At the top of the limb A there is a lateral passage in which a plunger L is made to reciprocate to and fro under the mouth of a feed hopper M. At the top of the limb B there is a lateral opening N for discharge of the spent material. Also from the bottom bend there is a passage O for drawing off the amalgam. The vessel being charged with mercury, and the shafts C and D being caused to revolve, and the plunger L being caused to reciprocate by connection to any suitable motor, the ore, tailings, or other material to be treated is fed into the hopper M, and is acted on as follows:—At every back stroke of the plunger L a portion of the material descends from the hopper. By the forward stroke of L this is forced into the upper part of the limb A, and partly by the pressure due to the stroke of the plunger, and partly by the action of the revolving blades E, the material is made to descend through the mercury, the grids G sub-dividing and distributing it as it descends. From the bottom bend of the apparatus the material ascends through the mercury in the limb B, and is finally discharged by the opening N, having in its course through the mercury left a large portion of the precious metal which it contained amalgamated with the mercury. Should farther amalgamation be required, the material discharged at N may be led to the hopper of another similar apparatus to be operated on a second time, and from this it may be led to a third or to several successive amalgamators arranged so that the process may go on continuously. The amalgam or the mercury can when required be withdrawn by opening a valve in the outlet pipe O.

Figs. 5, 6, and 7 show respectively a vertical section and cross-sections at, and Y Y of a modified arrangement, in which a screw L is employed in place of the plunger in the foregoing arrangement for forcing the material from the hopper into the amalgamating vessel, which, instead of being of a U shape, consists of the central part A, with shaft C, blades F, and grids G, through which the material is caused to descend, and which is supported by feet H on the bottom of the outer vessel B, into which the material issues from the bottom of A, in a finely-divided state. In this outer vessel, which is filled with mercury, the material ascends, giving off the precious metals contained therein to the mercury, and escaping through the opening N.

Figs. 8, 9, and 10 show the same views of a modification of the last-described arrangement, in which the hopper M is arranged directly over the central vessel A, the screw L which forces the material down into A being fixed on the same shaft C that drives the blades F.

In the arrangement shown at figs. 11, 12, and 13, the hopper M is made of such a depth that the weight of the column of material contained therein will be sufficient to force it down into the vessel A without the aid of a screw or plunger.

Having thus described the nature of my said invention, and in what manner the same is to be performed, I claim—

First—The construction of amalgamating apparatus, consisting of a vertical vessel or chamber charged with mercury or other liquid amalgamating metal, into the upper end of which vessel the ore or material to be operated upon enters, and in which it is caused to descend by the action of revolving helical blades, so as to issue at bottom into a second vertical vessel also charged with mercury or other metal in which the material is caused to ascend, transverse grids being provided in the first-named vessel for dividing and distributing the material as it descends, so as to bring it into intimate contact with the mercury, substantially as herein described.

Second—In combination with amalgamating apparatus constructed and operating as set forth in the preceding claim, the use of a plunger or equivalent device for forcing the material from the charging hopper into the amalgamating vessels, substantially as herein described.

Third—In amalgamating apparatus, the combination of the vessels A and B with grids G, H, shafts C, D, blades E, F, hopper M, and charging device L, arranged and operating, substantially as herein described with reference to figs. 1 to 4 of the drawings.

Fourth—In amalgamating apparatus the combination of the concentric vessels A B with grids G, shaft C, blades F, and hopper M, arranged and operating, substantially as herein described with reference to figs. 5 to 13 of the drawings.

In witness whereof, I, the said Adam Miller, have hereunto set my hand and seal, this twelfth day of September, in the year of our Lord one thousand eight hundred and eighty-four.

Witness—

ADAM MILLER.

OLIVER IMRAY, Patent Agent, 28, Southampton Buildings, London, W.C.

This is the specification, marked A, referred to in the annexed Letters of Registration granted to Adam Miller, the thirteenth day of December, A.D. 1884.

AUGUSTUS LOFTUS.

REPORT

Amalgamating Apparatus.

REPORT.

Sir,

Sydney, 29 October, 1884.

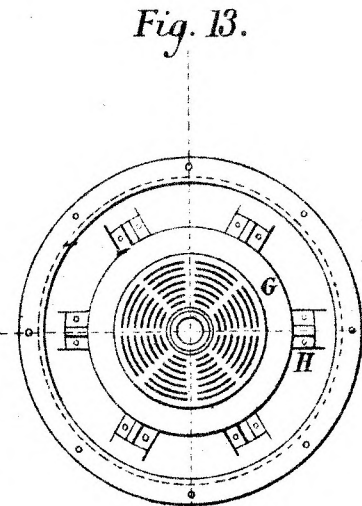
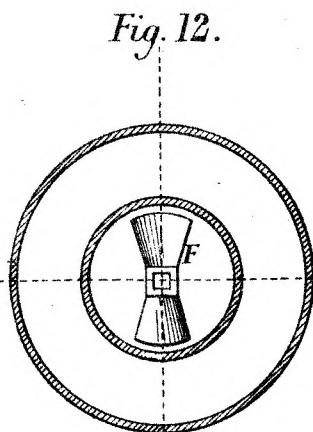
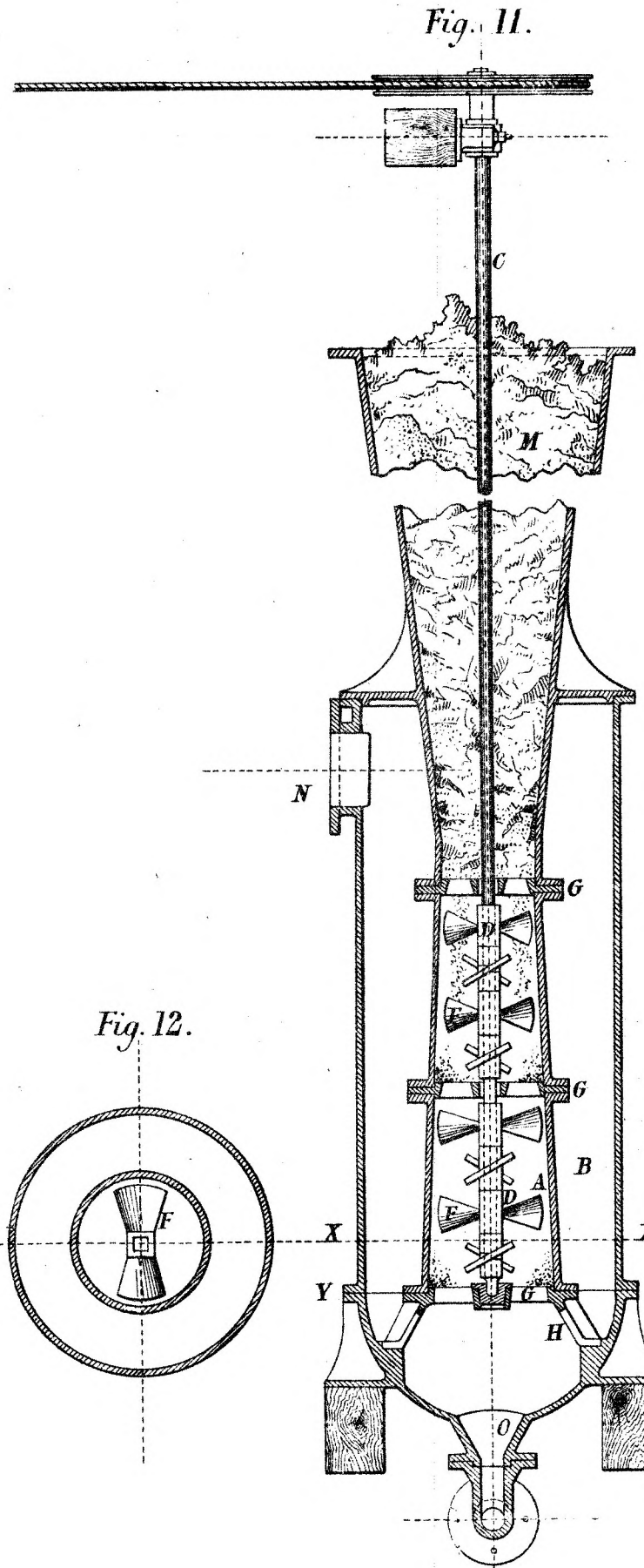
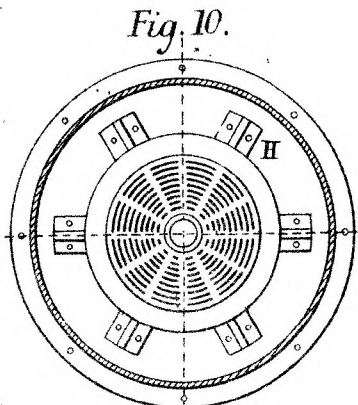
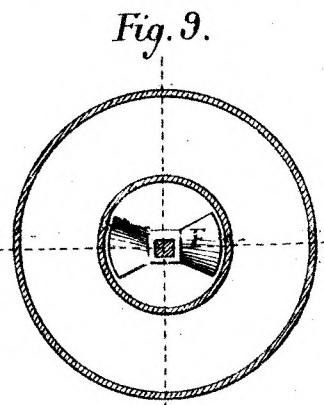
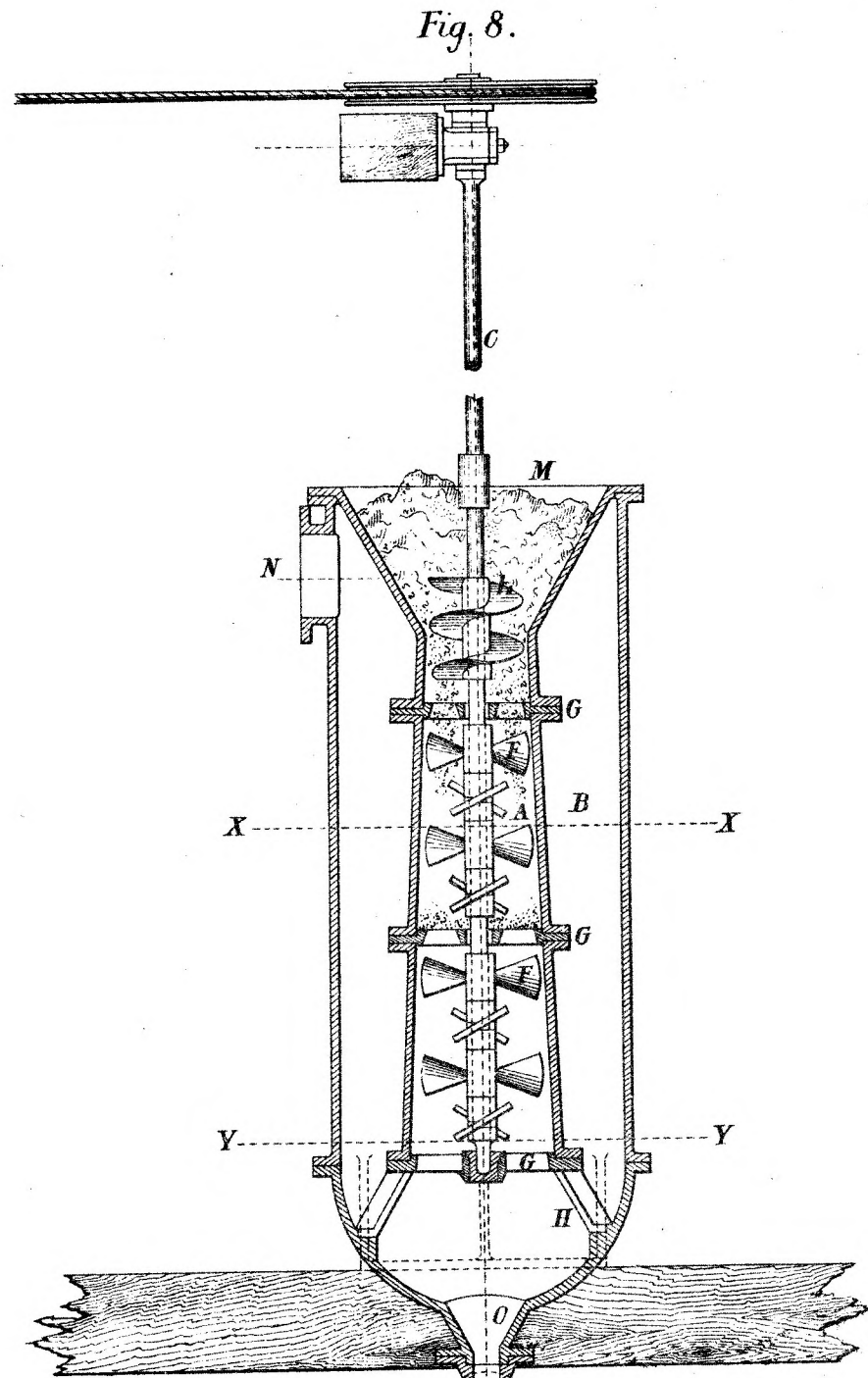
The application of Mr. Adam Miller for Letters of Registration for "An Amalgamating Apparatus" having been referred to us, we have examined the specification and drawings accompanying the same, and have now the honor to report that we see no objection to the issue of Letters of Registration as prayed for.

We have, &c.,

J. SMITH,
A. LEIBIUS.

The Under Secretary of Justice.

[Drawings—two sheets.



(Sig. 245.)

This is the Sheet of Drawings marked C, referred to in the annexed Letters of Registration, granted to Adam Miller, the thirteenth day of December, A. D., 1884.

Augustus Loftus.

PHOTO-LITHOGRAPHED AT THE GOVT. PRINTING OFFICE, SYDNEY, NEW SOUTH WALES.

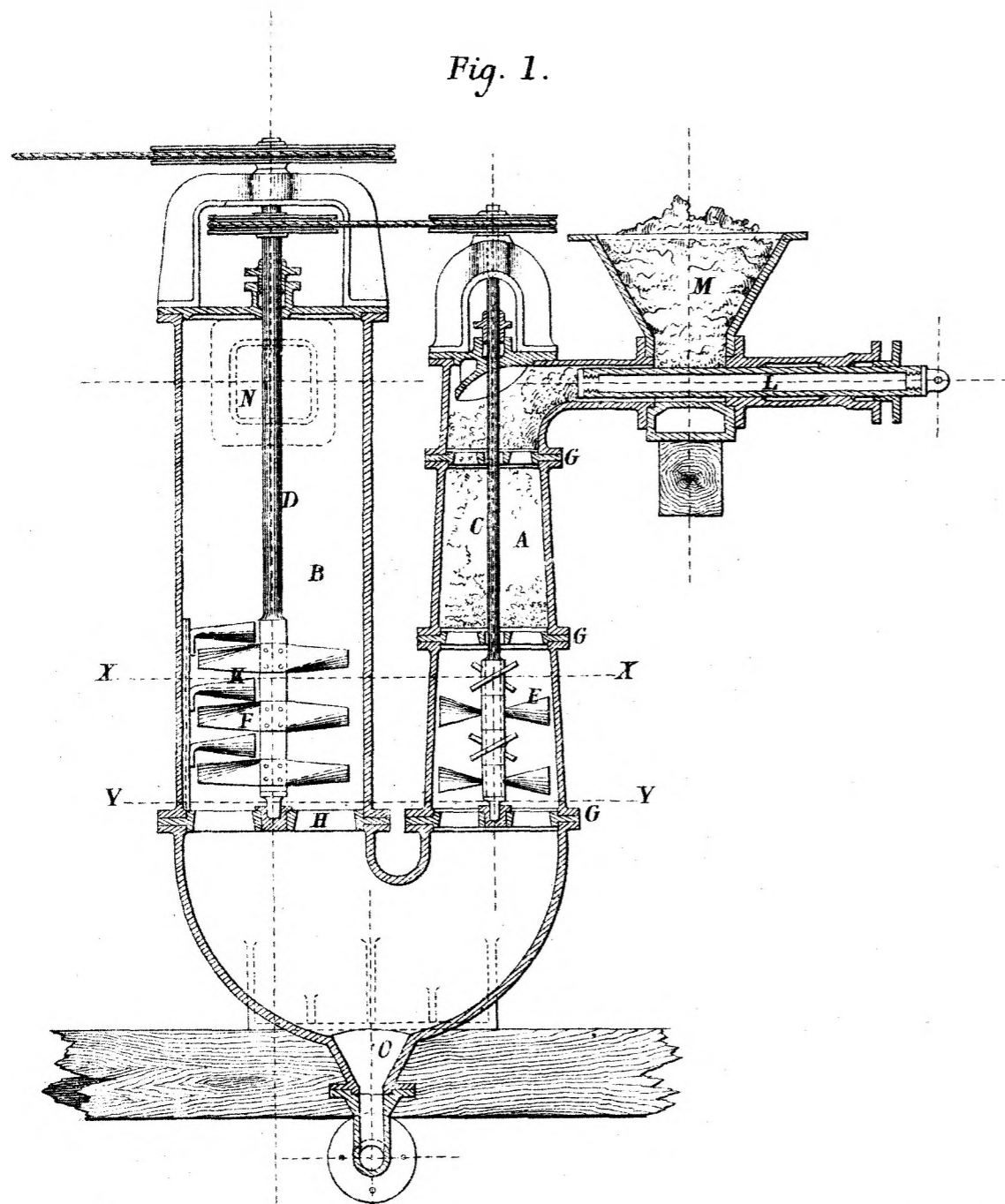


Fig. 1.

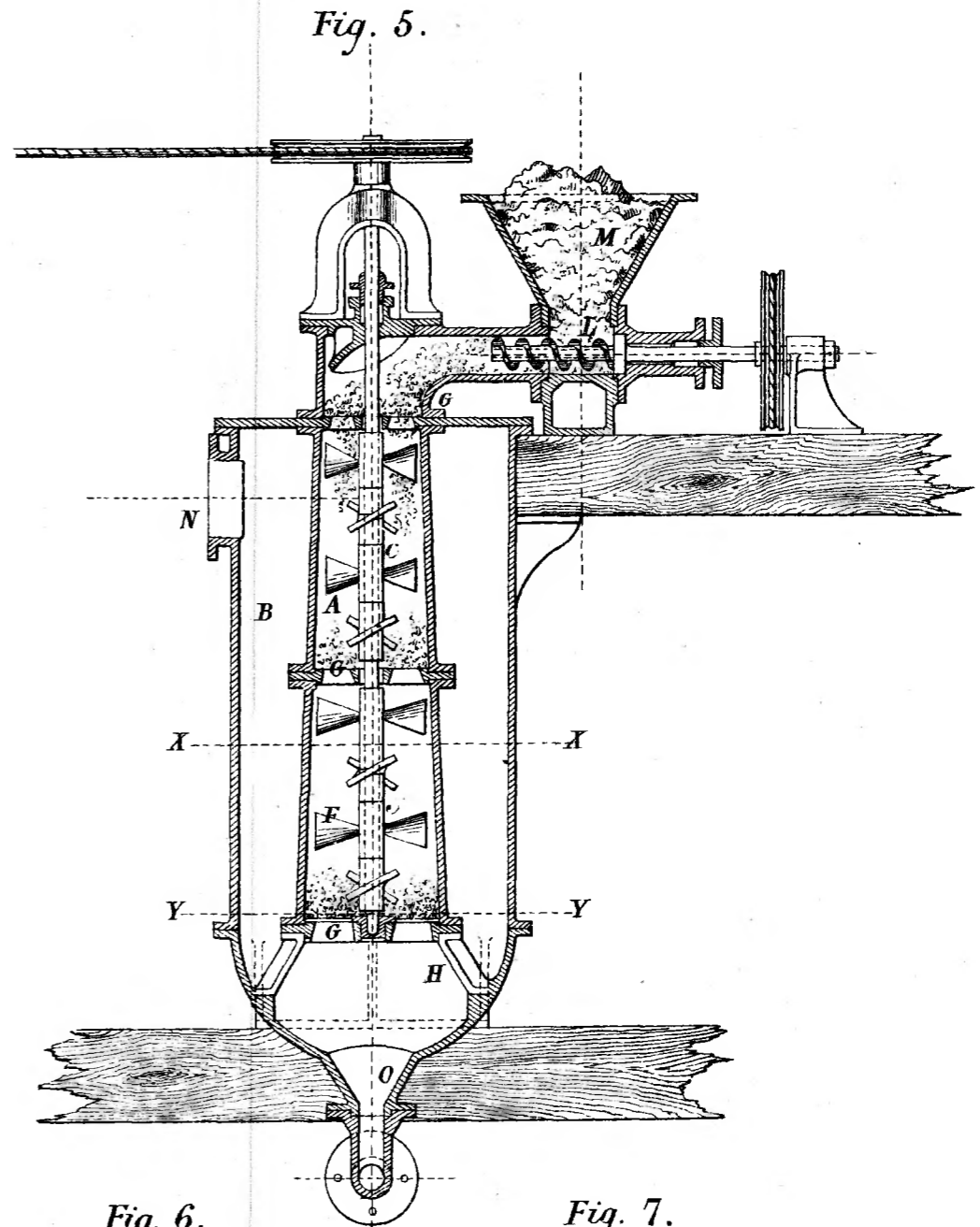


Fig. 5.

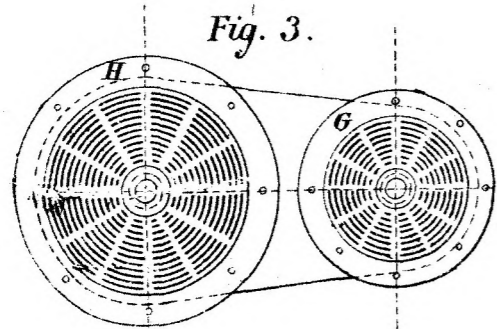


Fig. 3.

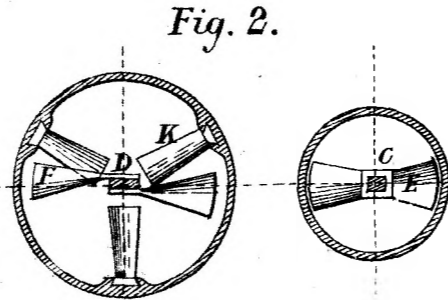


Fig. 2.

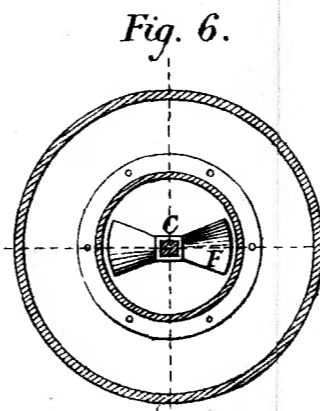


Fig. 6.

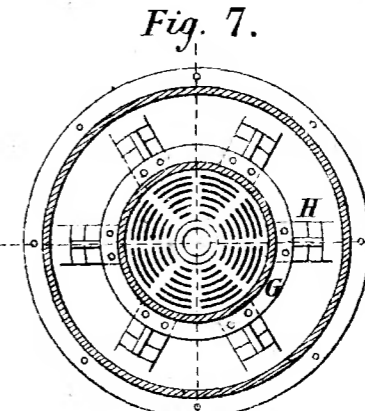


Fig. 7.

(Sig. 245)

This is the Sheet of Drawings marked B, referred to in the annexed Letters of Registration, granted to Adam Miller, the thirteenth day of December, A.D. 1884. Augustus Loftus.



A.D. 1884, 13th December. No. 1541.

IMPROVEMENTS IN VERTICAL REVOLVING STANDS.

LETTERS OF REGISTRATION to Hugh Thomas Smith, for Improvements in Vertical Revolving Stands, suitable for exhibiting wares and other articles.

[Registered on the 15th day of December, 1884, in pursuance of the Act 16 Vic. No. 24.]

BY HIS EXCELLENCY THE RIGHT HONORABLE SIR AUGUSTUS WILLIAM FREDERICK SPENCER LOFTUS (commonly called LORD AUGUSTUS LOFTUS), Knight Grand Cross of the Most Honorable Order of the Bath, a Member of Her Majesty's Most Honorable Privy Council, Governor and Commander-in-Chief of the Colony of New South Wales and its Dependencies.

TO ALL TO WHOM THESE PRESENTS SHALL COME, greeting:

WHEREAS HUGH THOMAS SMITH, of No. 43, Sussex-street, in the city of Sydney, and Colony of New South Wales, engineer, hath by his Petition humbly represented to me that he is the author or designer of a certain invention or improvement in manufactures, that is to say, of an invention entitled "Improvements in Vertical Revolving Stands, suitable for exhibiting wares and other articles," which is more particularly described in the specification and the sheet of drawings which are hereunto annexed; and that he, the said Petitioner, hath deposited with the Honorable the Treasurer of the said Colony of New South Wales the sum of Twenty Pounds sterling, for defraying the expense of granting these Letters of Registration, as required by the Act of Council, sixteenth Victoria, number twenty-four; and hath humbly prayed that I would be pleased to grant Letters of Registration, whereby the exclusive enjoyment and advantage of the said invention or improvement might be secured to him for a period of fourteen years: And I, being willing to give encouragement to all inventions and improvements in the arts or manufactures which may be for the public good, and having received a report favourable to the prayer of the said Petition, from competent persons appointed by me to examine and consider the matters stated therein and to report thereon for my information, am pleased, with the advice of the Executive Council, and in exercise of the power and authority given to me by the said Act of Council, to grant, and do by these Letters of Registration grant unto the said Hugh Thomas Smith, his executors, administrators, and assigns, the exclusive enjoyment and advantage of the said invention or improvement, for and during the term of fourteen years from the date hereof; to have, hold, and exercise unto the said Hugh Thomas Smith, his executors, administrators, and assigns, the exclusive enjoyment and advantage thereof, for and during and unto the full end and term of fourteen years from the date of these presents next and immediately ensuing, and fully to be complete and ended: Provided always, that if the said Hugh Thomas Smith shall not, within three days after the granting of these Letters of Registration, register the same in the proper office in the Supreme Court, at Sydney, in the said Colony of New South Wales, then these Letters of Registration, and all advantages whatsoever hereby granted, shall cease and become void.

In witness whereof, I have hereunto set my sign manual, and have caused the present Letters of Registration to be sealed with the seal of the said Colony of New South Wales, at Government House, Sydney, in New South Wales, this thirteenth day of December, in the year of our Lord one thousand eight hundred and eighty-four.

[L.S.]

AUGUSTUS LOFTUS.

Improvements in Vertical Revolving Stands.

SPECIFICATION of HUGH THOMAS SMITH, of No. 43, Sussex-street, in the city of Sydney, and Colony of New South Wales, engineer, for an invention entitled "Improvements in Vertical Revolving Stands, suitable for exhibiting wares and other articles."

THIS invention relates to vertical structures or stands on which wares and other articles are exhibited, and which may be continuously revolved; and it has been devised so that a greater weight than has hitherto been possible may be supported and exhibited by or upon such "revolving show-stands" (as they are called), and so that there is practically no limit to their size.

My improvements in vertical revolving stands for exhibiting wares and other articles consist essentially in supporting or floating the superincumbent weight of said stands and the exhibits thereon by or upon a body of water or other fluid; and, secondly, in their peculiar construction.

My improved vertical revolving show-stand consists of three main parts—a tank, tub, or bucket for holding a body of water or other fluid to support or float the superincumbent weight; a floatation vessel which fits within said tank, tub, or bucket, and on which the stand proper or shelf structure sits or rests; and a vertical spindle for imparting the motion. The shape of said first two parts is preferably cylindrical, the tank, tub, or bucket having no top or cover, and its bottom being flat, except a central portion which rises in the shape of a cone, whose apex reaches to or is above the maximum water-level in said tank, tub, or bucket. The bottom of the floatation vessel has also a cone in the centre, which will fit over the said central cone in the tank. The vertical spindle passes up from a foot-step or other bearing through each apex of said two cones, and engages in a socket-hole, which may slide vertically upon said spindle, and which is attached to the cone of the floatation vessel or to the base of the shelf structure.

But, in order that my invention may be clearly understood, I will now describe the same with reference to the drawings herewith, in which fig. 1 shows a sectional elevation of a vertical revolving show-stand constructed according thereto; and fig. 2 a plan of the underside of same; fig. 3 is a sectional elevation of the parts which comprise my invention; and figs. 4 and 5 show, in sectional elevation, modifications of the manner in which the vertical spindle is supported. Similar letters of reference indicate similar parts wherever they occur.

A is the water-tank; B the floatation vessel (both preferably constructed of galvanized iron); C the vertical spindle; and D the stand proper or shelf structure; A¹ and B¹ are central cones on bottom of tank A and vessel B respectively; A² is water or other fluid, A³ marking its level; C¹ is foot-step or bottom bearing; C² upper part (preferably square) of spindle C; and C³ its engaging socket, attached to cone B¹ or base D; D¹, D², and D³ are shelves. In figs. 1 and 2, E are legs to the floor or other support; F is falling weight; F¹ governing mechanism; and F² pulley or spindle C. The spindle C may pass through hole in plate C³ attached to base D and be supported by footstep C¹ and cone A¹ (see fig. 3), or be supported by sleeve-bearing C¹ (see fig. 4); or, again, it may pass through socket C³ on cone B¹, and itself be attached by means of flange C¹ to base D and slide in bearing C¹ and through and engaging (say) bevel wheel F (see fig. 5), or be protected from the fluid and be supported in various other ways that may suggest themselves in practice.

In operation, motion is imparted to the stand D by means of spindle C, which is revolved by mechanism in any well-known manner. In figs. 1 and 2 I have shown a falling-weight and cord with a hair-spring governing mechanism, as is well understood for this purpose. As weight is added to or upon the stand, the vessel B will sink deeper in the water or fluid A² in the tank A, the socket C³ sliding downwards upon the spindle C, or said spindle C sliding through its bearings (see fig. 5); and such addition of weight will not add any weight to that which the spindle C supports, but will be supported by the body of water in the tank A. It will be seen also that the cones A¹ and B¹ might be of any other shape so long as the spindle C is protected from the fluid—for instance, they might be telescopic cylinders; but I prefer to make them conical, as I consider that shape to be the strongest.

Having thus particularly described and ascertained the nature of this invention, and the manner in which the same is to be performed, I would have it understood that I do not confine myself to any form, size, or material of which my improved stands may be constructed, nor to any particular means of revolving same, so long as the nature thereof be retained; but what I believe to be novel, and therefore claim as of my invention, is—

First—Supporting or floating the superincumbent weight of revolving stands and the exhibits thereon by or upon a body of water or other fluid, substantially as herein described and explained.

Second—Enclosing the vertical spindle of such stands by telescopic cones or other protectors, substantially as herein described and explained, and as illustrated in the drawings.

Third—The combination and arrangement of parts, substantially as herein described and explained, and as illustrated in figs. 3, 4, and 5 respectively of the drawings.

In witness whereof, I, the said Hugh Thomas Smith, have hereunto set my hand and seal, this thirteenth day of October, one thousand eight hundred and eighty-four.

Witness—

FRED. WALSH,

Manager, Edwd. Waters' Patent Office, Sydney.

H. T. SMITH.

This is the specification referred to in the annexed Letters of Registration granted to Hugh Thomas Smith, the thirteenth day of December, A.D. 1884.

AUGUSTUS LOFTUS.

H. T. SMITH'S PATENT

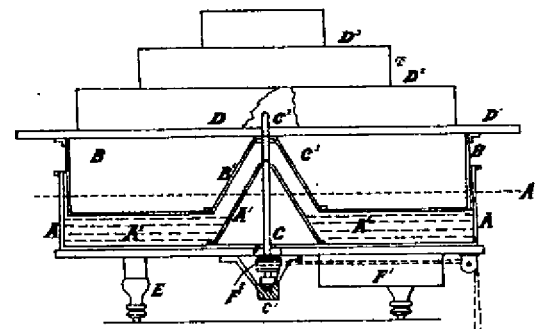


Fig 1.

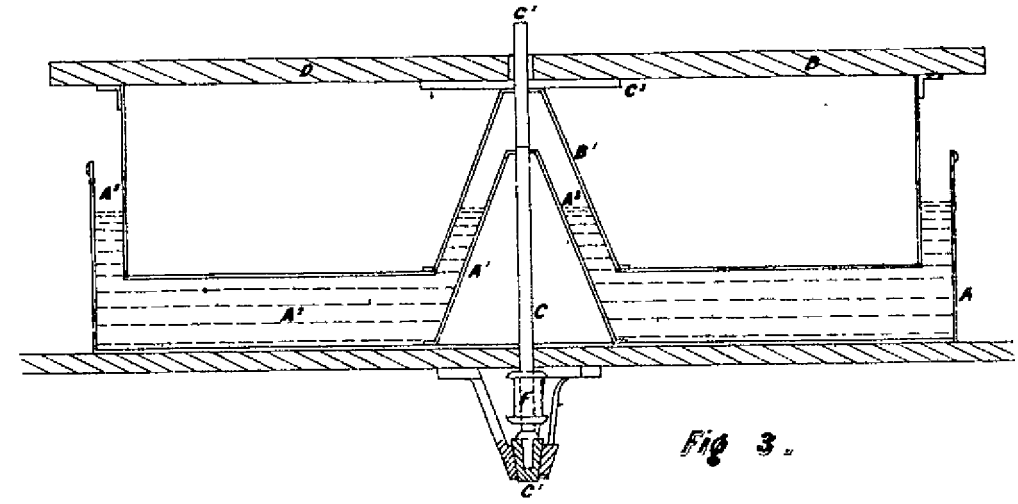


Fig 3.

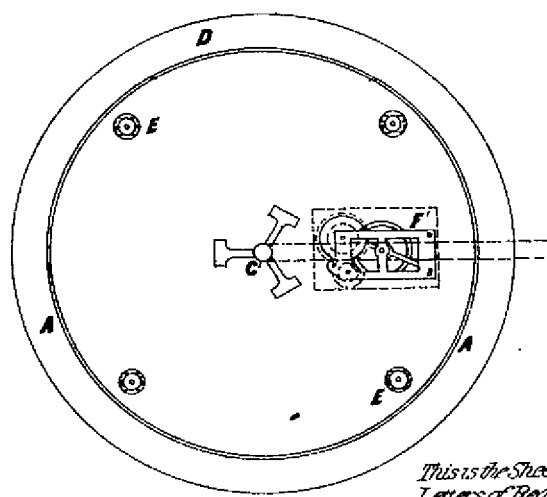


Fig 2.

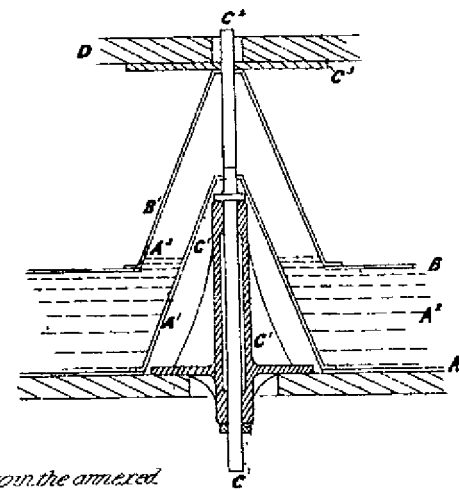


Fig 4.

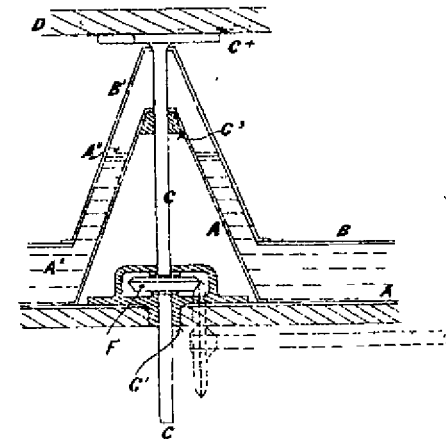
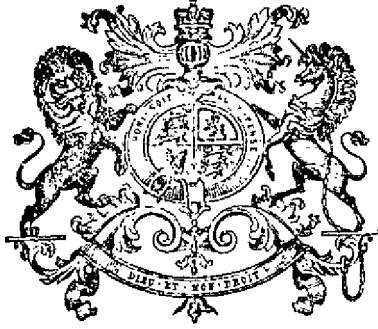


Fig 5.

*This is the Sheet of Drawings referred to in the annexed
 Letters of Registration granted to Hugh Thomas
 Smith, the thirteenth day of December, AD. 1884.
 Augustus Loftus.*



A.D. 1884, 13th December. No. 1542.

IMPROVEMENTS IN FLEXIBLE DRIVING GEAR.

LETTERS OF REGISTRATION to Frederick York Wolseley and Richard Pickup Park, for Improvements in Flexible Driving Gear.

[Registered on the 15th day of December, 1884, in pursuance of the Act 16 Vic. No. 24.]

BY HIS EXCELLENCY THE RIGHT HONORABLE SIR AUGUSTUS WILLIAM FREDERICK SPENCER LOFTUS (commonly called LORD AUGUSTUS LOFTUS), Knight Grand Cross of the Most Honorable Order of the Bath, a Member of Her Majesty's Most Honorable Privy Council, Governor and Commander-in-Chief of the Colony of New South Wales and its Dependencies.

TO ALL TO WHOM THESE PRESENTS SHALL COME, greeting :

WHEREAS FREDERICK YORK WOLSELEY, of Walgett, in the Colony of New South Wales, gentleman, and RICHARD PICKUP PARK, of Yarra Bank, Melbourne, in the Colony of Victoria, engineer, have by their Petition humbly represented to me that they are the authors or designers of a certain invention or improvement in manufactures, that is to say, of an invention entitled "Improvements in Flexible Driving Gear," which is more particularly described in the specification and the sheet of drawings which are hereunto annexed; and that they, the said Petitioners, have deposited with the Honorable the Treasurer of the said Colony of New South Wales the sum of Twenty Pounds sterling, for defraying the expense of granting these Letters of Registration, as required by the Act of Council, sixteenth Victoria, number twenty-four; and have humbly prayed that I would be pleased to grant Letters of Registration, whereby the exclusive enjoyment and advantage of the said invention or improvement might be secured to them for a period of fourteen years: And I, being willing to give encouragement to all inventions and improvements in the arts or manufactures which may be for the public good, and having received a report favourable to the prayer of the said Petition, from competent persons appointed by me to examine and consider the matters stated therein and to report thereon for my information, am pleased, with the advice of the Executive Council, and in exercise of the power and authority given to me by the said Act of Council, to grant, and do by these Letters of Registration grant unto the said Frederick York Wolseley and Richard Pickup Park, their executors, administrators, and assigns, the exclusive enjoyment and advantage of the said invention or improvement, for and during the term of fourteen years from the date hereof; to have, hold, and exercise unto the said Frederick York Wolseley and Richard Pickup Park, their executors, administrators, and assigns, the exclusive enjoyment and advantage thereof, for and during and unto the full end and term of fourteen years from the date of these presents next and immediately ensuing, and fully to be complete and ended: Provided always, that if the said Frederick York Wolseley and Richard Pickup Park shall not, within three days after the granting of these Letters of Registration, register the same in the proper office of the Supreme Court, at Sydney, in the said Colony of New South Wales, then these Letters of Registration, and all advantages whatsoever hereby granted, shall cease and become void.

In witness whereof, I have hereunto set my sign manual, and have caused the present Letters of Registration to be sealed with the seal of the said Colony of New South Wales, at Government House, Sydney, in New South Wales, this thirteenth day of December, in the year of our Lord one thousand eight hundred and eighty-four.

[L.S.]

AUGUSTUS LOFTUS.

Improvements in Flexible Driving Gear.

SPECIFICATION of **FREDERICK YORK WOLSELEY**, of Walgett, in the Colony of New South Wales, gentleman, and **RICHARD PICKUP PARK**, of Yarra Bank, Melbourne, in the Colony of Victoria, engineer, for an invention entitled "Improvements in Flexible Driving Gear."

OUR invention relates to that kind of driving gear which is suitable for working machines that have to be moved about while they are at work, such as sheep-shearing machines, and it consists in a novel construction of such gear. In our gear there are three main parts, viz., an inner core of wire-cord or rope, a surrounding coil of spiral wire, and an outer casing or covering of cloth, or indiarubber, or other flexible material. This wire-cord is the actuating part of our gear, the other parts simply forming a vehicle for containing it, and by which it can be used. Accordingly, the one end of said wire-cord is hooked on to or otherwise attached to a solid rod, to which rotary motion is given by any approved means, and the other end is hooked on to or otherwise attached to the end of a spindle, to which motion has to be imparted. This spindle may convey its motion to the operative parts of a machine in any approved way, although we have shown the best way known to us of conveying such motion to the cutter of sheep-shearing machines in a specification which we have deposited at the office of the Minister for Justice on the eighth day of October, one thousand eight hundred and eighty-four. Our flexible gear may also receive its motion from any suitable contrivance, but in the drawings hereto attached we have shown the best arrangement for the purpose which is known to us. In them, figure 1 shows plan, and figure 2 elevation of such an arrangement; figure 3 shows a section, on an enlarged scale, of the friction gear hereinafter referred to; whilst figure 4 shows exactly how our flexible gear is constructed, parts being broken away in order to show the construction more clearly. A is an ordinary framing and B the main shaft working in suitable bearings B¹, and having keyed on it the belt pulley B², to which motion is imparted, and also the rope pulley B³ for communicating motion by means of the driving belt C, which passes between guide pulleys C¹ and C², and around the pulley D formed on the lower half of the friction gearing, which lower half revolves freely on the hollow spindle E, whilst the upper half D¹ works freely up and down on the key E¹, but revolves with said spindle E; D² is a leather friction-piece fitted to D¹; F is the central spindle screwed at its top, and provided with nuts F and formed square at its lower end, so as to fit in a corresponding hole in the hollow spindle E; F² is a hook at its lower end, which is the point of connection between said spindle F and the flexible gear G, whilst H is the connection between said gear and the driving spindle of the shearing or other machine to which it is to be attached; G¹ is the wire cord, G² the spiral wire, and G³ the flexible outer casing. The upper half D¹ of the friction gearing is kept down and in gear with the lower half by the pressure of spiral spring J, and K is a lever, by means of which said upper half may be released from said lower half. At the end of this lever is a cord K¹, by pulling which such disconnection is effected, and when said lever is pulled down sufficiently to allow of its passing under spring catch L it will remain disconnected until released by cord L¹ pulling back such spring catch L so as to offer no resistance to the pressure of spring J on the upper half of the friction gear.

Having thus described the nature of our invention and the manner of performing same, we would have it understood that we do not claim the friction gear as our invention, but only show and describe it in order that the method of using our flexible gear may be clearly understood. We also wish it to be understood that we are aware that flexible gearing, having an outer covering of flexible material on a spiral wire is not a novelty; but what we believe to be new, and therefore claim as our invention, is—

The central core of wire-cord or rope G¹, in combination with the spiral wire G² and outer flexible casing G³, as and for a flexible driving gear, substantially as herein described and explained

In witness whereof we, the said Frederick York Wolseley and Richard Pickup Park, have hereto sets our hands and seals this fifteenth day of October, one thousand eight hundred and eighty-four.

F. Y. WOLSELEY.
R. P. PARK.

Witness to the signature of Frederick York Wolseley—
ROBT. B. WILKINSON, Sydney,
Stock and Station Agent.

Witness to the signature of Richard Pickup Park—
W. S. BAYSTON,
Clerk to Edwd. Waters,
Patent Agent, Melbourne.

This is the specification referred to in the annexed Letters of Registration granted to Frederick York Wolseley and Richard Pickup Park, the thirteenth day of December, A.D. 1884.

AUGUSTUS LOFTUS.

REPORT.

Sir,

We do ourselves the honor to report, in reply to your blank cover, Sydney, 31 October, 1884. opinion the prayer of the Petitioners, Messrs. Frederick York Wolseley and Richard Pickup Park, for the registration of an invention entitled "Improvements in Flexible Driving Gear," may be granted, in terms of their specification, drawings, and claim.

We have, &c.,
GOTHER K. MANN.
EDMUND FOSBERY.

The Under Secretary of Justice.

WOLSELEY & PARK'S PATENT

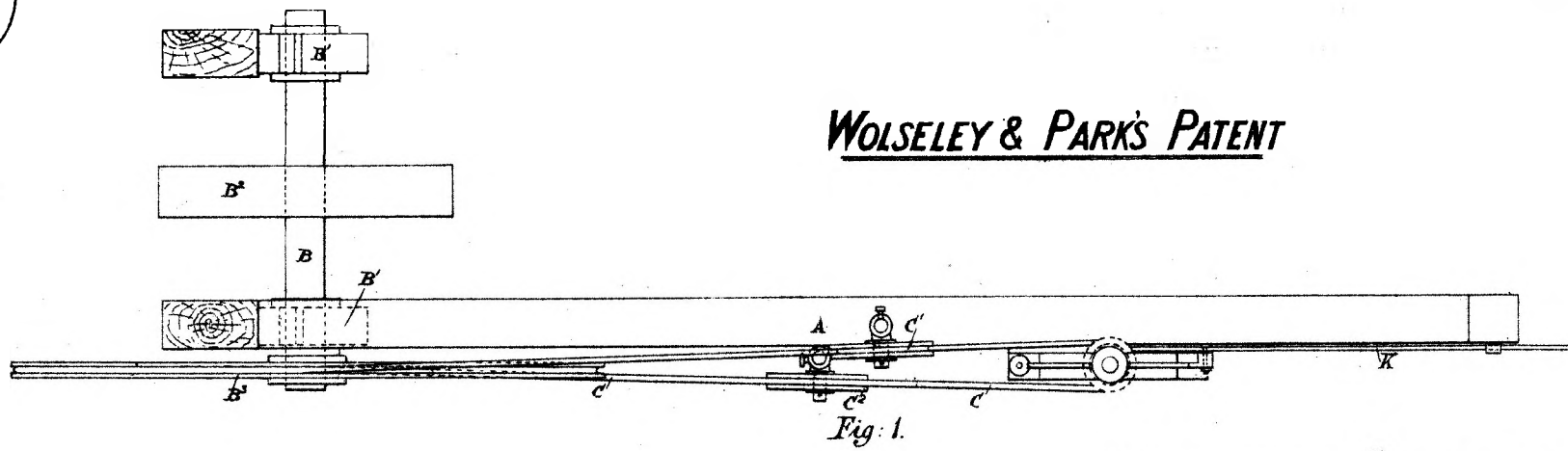


Fig. 1.

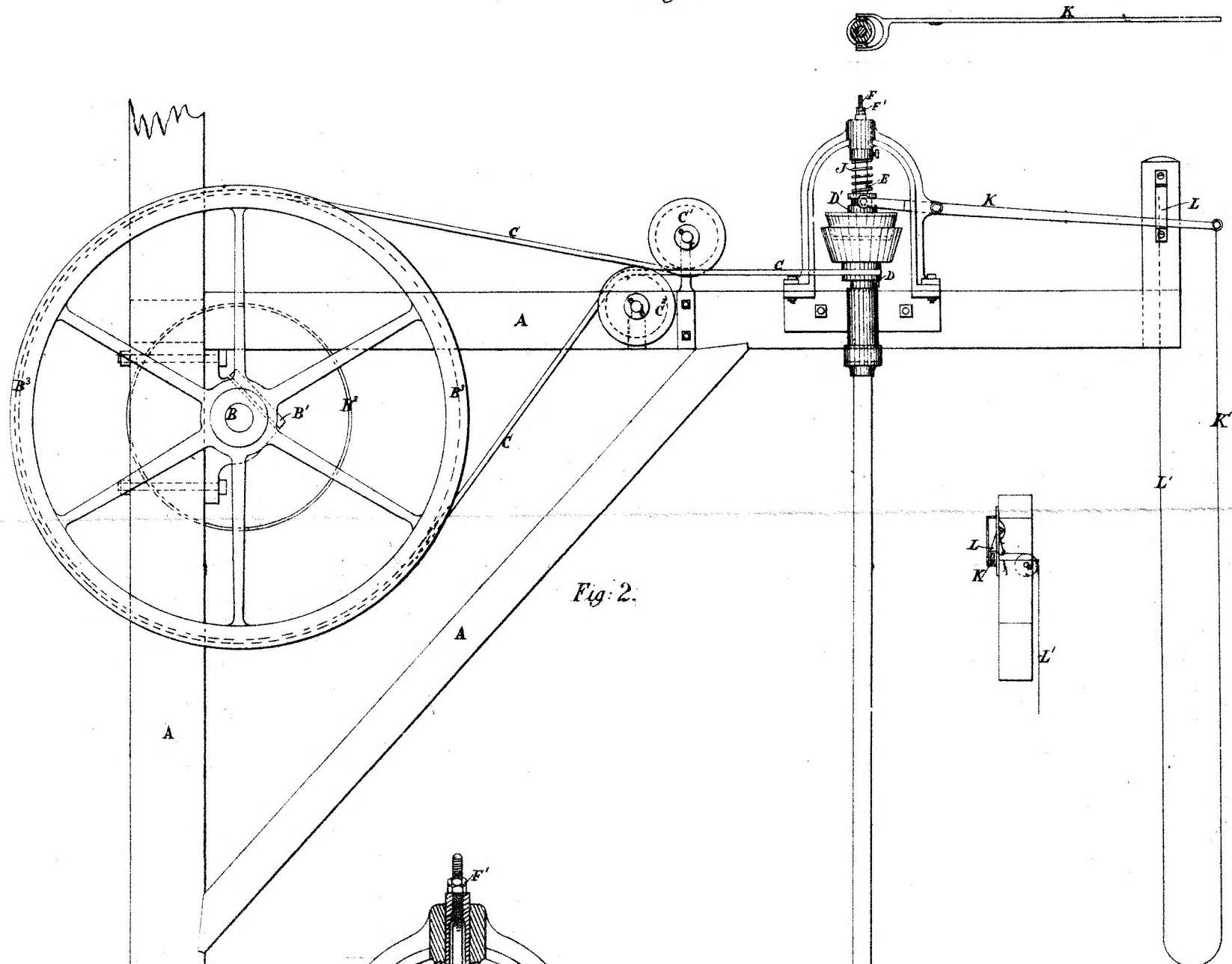


Fig. 2.

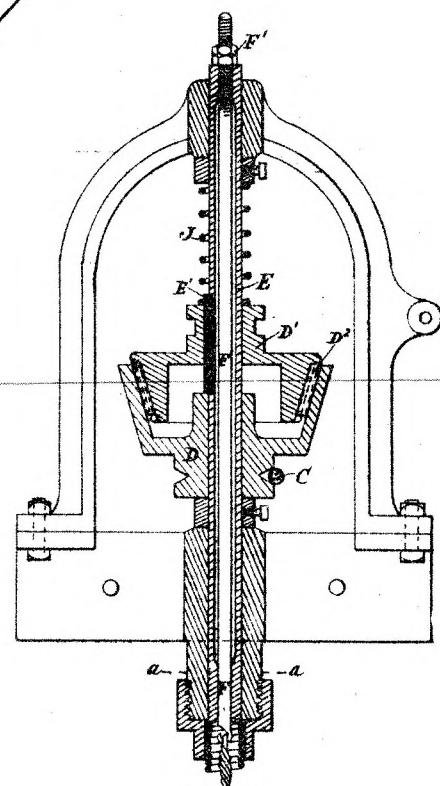
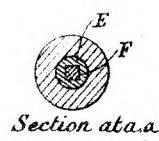
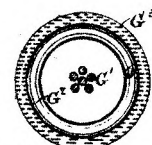


Fig. 3.



Section at a a



Section at b b

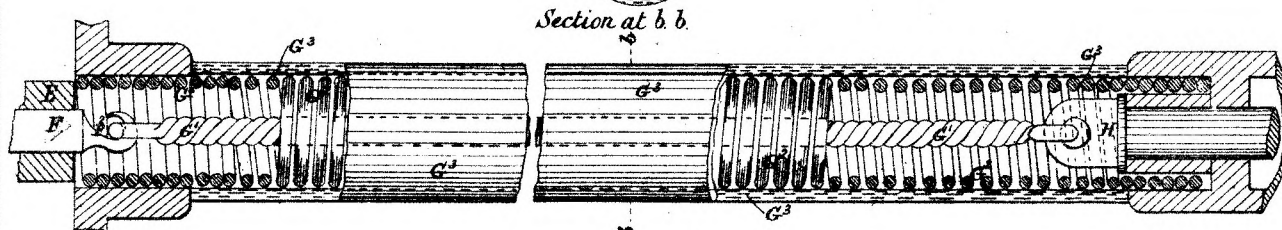


Fig. 4.

*This is the Sheet of Drawings referred to in the
annexed Letters of Registration granted to
Frederick Kirk Wolseley the thirteenth day of
December A.D. 1884. Augustus Lottis.*



A.D. 1884, 17th December. No. 1543.

IMPROVEMENTS IN REAPING AND BINDING MACHINES.

LETTERS OF REGISTRATION to Lewis Miller for Improvements in Reaping and Binding Machines.

[Registered on the 18th day of December, 1884, in pursuance of the Act 16 Vic. No. 24.]

BY HIS EXCELLENCY THE RIGHT HONORABLE SIR AUGUSTUS WILLIAM FREDERICK SPENCER LOFTUS (commonly called LORD AUGUSTUS LOFTUS), Knight Grand Cross of the Most Honorable Order of the Bath, a Member of Her Majesty's Most Honorable Privy Council, Governor and Commander-in-Chief of the Colony of New South Wales and its Dependencies.

TO ALL TO WHOM THESE PRESENTS SHALL COME, greeting :

WHEREAS LEWIS MILLER, of Akron, in the State of Ohio, one of the United States of America, hath by his Petition humbly represented to me that he is the author or designer of a certain invention or improvement in manufactures, that is to say, of an invention entitled "Improvements in Reaping and Binding Machines," which is more particularly described in the amended specification marked A, and the three sheets of drawings, marked B, C, and D, respectively, which are hereunto annexed ; and that he, the said Petitioner, hath deposited with the Honorable the Treasurer of the said Colony of New South Wales the sum of Twenty Pounds sterling, for defraying the expense of granting these Letters of Registration, as required by the Act of Council, sixteenth Victoria, number twenty-four ; and hath humbly prayed that I would be pleased to grant Letters of Registration, whereby the exclusive enjoyment and advantage of the said invention or improvement might be secured to him for a period of fourteen years : And I, being willing to give encouragement to all inventions and improvements in the arts or manufactures which may be for the public good, and having received a report favourable to the prayer of the said Petition, from competent persons appointed by me to examine and consider the matters stated therein and to report thereon for my information, am pleased, with the advice of the Executive Council, and in exercise of the power and authority given to me by the said Act of Council, to grant, and do by these Letters of Registration grant unto the said Lewis Miller, his executors, administrators, and assigns, the exclusive enjoyment and advantage of the said invention or improvement, for and during the term of fourteen years from the date hereof ; to have, hold, and exercise unto the said Lewis Miller, his executors, administrators, and assigns, the exclusive enjoyment and advantage thereof, for and during and unto the full end and term of fourteen years from the date of these presents next and immediately ensuing, and fully to be complete and ended : Provided always, that if the said Lewis Miller shall not, within three days after the granting of these Letters of Registration, register the same in the proper office in the Supreme Court, at Sydney, in the said Colony of New South Wales, then these Letters of Registration, and all advantages whatsoever hereby granted, shall cease and become void.

In witness whereof, I have hereunto set my sign manual, and have caused the present Letters of Registration to be sealed with the seal of the said Colony of New South Wales, at Government House, Sydney, in New South Wales, this seventeenth day of December, in the year of our Lord one thousand eight hundred and eighty-four.

[L.S.]

AUGUSTUS LOFTUS.

Improvements in Reaping and Binding Machines.

A

SPECIFICATION of LEWIS MILLER, of Akron, in the State of Ohio, one of the United States of America, for an invention entitled "Improvements in Reaping and Binding Machines."

My invention relates in general terms to improved connections and arrangements of parts wherein the frame of the machine is supported and adjusted upon wheels screwed to the grain and stubble ends, upon and between which the grain is cut, raked, bound, and elevated from a lower cutting or ground platform, over an inclined binder platform, and discharged upon the stubble side of the driving wheel, and out of the way of the team in its succeeding round.

My invention further relates to certain improvements in the frame-work of the machine, and to means for connecting the frame to, and for effecting the adjustment of said frame and its attachments on the driving and grain wheels.

My invention further relates to an improved construction and arrangement of mechanism for picking or gathering, and for packing and binding the grain during its passage over the inclined binder table, and for ejecting the bundle therefrom over the wheel, and to an improved butting mechanism, arranged upon said inclined binder table, and to means for adjusting same.

My invention further relates to an improved organization relative to the machine frame-work, of devices by which the binding arm or needle and packers, and also by which the cutting apparatus and reel are operated from the binder mechanism instead of having the binder made as a removable attachment to the harvester, and with its driving mechanism taking motion from the cutter and reel driving mechanism of the harvester as has heretofore been usual in machines of this class.

My invention further relates to an improved manner of arranging the gear standard and to supporting the pickers or gatherers from said gear standard, to supporting the driver's seat and foot-board upon the gear standard, and to the manner of arranging, supporting, and adjusting the reel.

My invention further relates to the manner of connecting the driving-wheel and the main binder-gear shaft, and of connecting the main binder-gear shaft with the cutter bar, and also with the reel, butter, and picker or packer shaft, and to improvements in the tripping mechanism for throwing the knottor mechanism in gear with the main binder-gear shaft.

My invention further relates to the peculiar construction of the driving and supporting wheels, to a hinged board for supporting the heads of long grain that may overhang the carrier and binder platforms, and to certain other details of construction and arrangement of parts hereinafter explained.

In the accompanying drawings, figure 1 is a plan view of the machine with the platform, reel, and finger bar broken away. Figure 2 a front elevation of the parts shown in figure 1, and also showing the grain wheel, the platform being broken away and removed to contract the length of the figure. Figure 3 a rear elevation of the parts shown in figure 2. Figure 4 a view in elevation of the grain side of the machine. Figure 5 a similar view of the stubble side of the machine. Figure 6 a plan view of the part of the binder frame and mechanism shown by removing the inclined binder table. Figure 7 a perspective view of the butter and its connections (showing the gearing for operating it, and also for operating the picker and reel). Figure 8 a vertical section in the line X X of figure 1, showing the end of the conveyor, the inclined binder table, the packers, pickers, needle arm, compressors, and ejectors to illustrate the action of said parts as the grain is delivered to be elevated and bound, and the bound bundles ejected from the machine. Figure 9 a perspective view of the packers, needle arm, upper compressor, and ejector, as seen when looking from the front stubble corner to the rear grain corner of the machine. Figure 10 a perspective view of the pickers detached. Figure 11 a side elevation of the brackets for supporting the raised end of the inclined binder table and the gearing for connecting the driving-wheel chain and main binder-gear shaft. Figure 12 is a plan view of the main and binder frame, with the gearing, binding, cutting, and reel mechanism and platform removed, and showing the devices for supporting and adjusting the height of the frame. Figure 13 is a perspective view of the drive-wheel and a portion of the frame, looking from a point on the inner side of, and behind the driving wheel, showing said wheel, the manner of its attachment to the frame, and the means in part for effecting the adjustment of the latter.

The main platform frame is formed of the front and rear transverse sills A A¹, connected at the grain end by a longitudinal sill A², and at the stubble end by a floor brace A³, and also by a iron bar A⁴, connecting brackets secured to the ends of the sills A A¹, as will hereinafter appear.

The brackets above referred to consist of a segmental bracket B, to which a sliding stud axle C¹ for the drive-wheel C may be secured and adjusted, and also in pillow block brackets B¹ B², that support in an elevated position the upper longitudinal tubular bar D of an inclined binder frame. A similar tubular bar D¹, arranged parallel to the bar D, is secured at a lower elevation, and upon the platform side of said bar, by bolting it to the front and rear sills A A¹ in suitable mortises, so as to be approximately upon a level with the grain platform. Transverse bars D² D³ are secured to the tubular bars D D¹, and together with them constitute the binder framework, which it will be seen is secured to the platform frame in an inclined position, extending from the platform to the top of the drive-wheel.

The transverse bar D⁴ is of plate metal, and has its outer end bent downward into a vertical position, and is curved to form the segment of a circle D¹, and forms a support upon which the sleeve C² of the stud axle C¹ may be adjusted. The main drive-wheel C is journalled upon the axle C¹ and supports the stubble end of the machine, and is made adjustable on the segmental bracket D⁴ to raise or lower the frame and cutter bar to any required distance from the ground, as will hereinafter appear. The bracket B¹ forms a stirrup to receive the end of the tongue B³, attached thereto by a bolt b, and the bracket B² is cast with suitable bearings for the gear shafts and a journal b¹, to which the rear end bar A⁴, above referred to, of the frame is attached, the front end of the said bar A⁴ being bolted to a projection from the segment bracket B, the bar A⁴ being thus inclined from the front to the rear of the machine, and in a radial line from the lower end of the segment bracket B to the main sprocket wheel shaft C³, that is supported in a transverse position upon bracket B² secured to the rear sill A¹ of the machine, and is driven directly by a chain J from the main drive-wheel. The bar A⁴ will not only hold the ends of the sills A A¹ securely together, but will secure fixed relationship between the hub sprocket C⁴ of the drive-wheel C when adjusted upon the segment
with

Improvements in Reaping and Binding Machines.

with the centre of the sprocket wheel shaft C³, as said segment is made radial with the sprocket shaft, in order that motion may be transmitted from the hub of the drive-wheel to the sprocket C³ on shaft C³, without varying the distance between them as the wheel is adjusted.

In suitable bearings on the inner face of the segmental bracket D¹, or the inner end of the transverse sill A, the last named parts being secured together, is mounted a longitudinal shaft E, provided on its forward end with a worm wheel E¹.

An upright shaft E² is stepped at its lower end in a suitable bearing *e*, secured to the end of the transverse sill A, and a boxing *e*¹, forming a part of said bearing serves to enclose the worm wheel E¹. The lower end of shaft E² is formed with a worm or screw *e*², which engages with the worm wheel E¹ for actuating it and the shaft E. The shaft E² extends upward through the eye-bearing attached to the driver's foot-board or seat support, either or both, in a suitable manner, and is provided at its upper end with a crank or hand wheel E³, arranged within convenient reach of the driver's seat, on the machine for enabling him to operate said shaft.

The shaft E has one end of a chain E⁴ attached to and wrapping it, and the other end of said chain extends up to and is connected with an eye or hook formed in or attached to the axle sleeve or bracket B at or near its upper end.

By operating the shaft E², and through it the shaft E for winding the chain upon the latter, said shaft E, with the binder frame, in which it has its bearings, will be drawn upwards, the segmental bracket D¹ moving in the sleeve B, until the desired height of adjustment of the frame at its inner end is obtained, while by rotating the shaft E² in a reverse direction, the weight of the frame serves to unwind the chain E⁴, allowing the frame to descend as required. The grain wheel F is connected by a stud axle *f*, with a quadrant lever or arm F¹ pivoted at its upper end to the outer face of the divider or outer end of the platform frame, and a chain F² extending from the upper end of the curved face of the quadrant F¹ down through a groove therein, and underneath a guiding roller on the bevel face of the platform frame, at its outer end, and thence transversely underneath said frame is connected with the shaft E in such a manner as to be wrapped thereon when said shaft is rotated for wrapping the chain E⁴ upon it, and to unwind therefrom when the chain E⁴ is unwound. By this arrangement the outer end of the platform frame is adjusted simultaneously with and to the same extent as the inner end, thus preserving the parallel relation of the platform to the ground. A finger bar F³ is secured to the front sill A, and supports a cutter bar F⁴ to be reciprocated thereon by means of a vibrating lever F⁵ pivoted midway of its length upon a longitudinal brace F⁶, connecting the front and rear sills A A¹ of the frame. The rear end of the lever F⁵ is connected by a ball and socket joint *f*¹, with the end of a pitman F⁷ arranged transversely to the machine in rear of the frame sill A¹. The other end of the pitman F⁷ is connected to a crank arm *f*² upon the end of a longitudinal shaft F⁸ that extends from the front to the rear of the frame, and is journaled upon the front and rear sills A A¹. A conveyer roller G is secured upon shaft F⁸, and a similar roller G¹ is arranged parallel thereto, upon the grain end of the frame, and is also supported at its ends upon bearings upon the sills A A¹; an endless conveyer or carrier belt G² passes around the rollers G G¹, and also above and beneath the longitudinal brace F⁶ and lever F⁵, and is provided with longitudinal strips *g g*, in a well known manner, to form a movable grain platform in rear of the cutter bar upon which the grain may be deposited and delivered to the foot of the inclined binder platform H arranged between the end of the carrier G² and the top of the drive-wheel. The binder platform H rests upon the transverse bars D² D³, and forms an inclined plane surface over which the grain may be freely carried. The packing ejector, compressor, and needle arms are arranged in the triangular space beneath the platform H, and suitable transverse slots in said platform permit the said arms to be vibrated up through the slots of said table to act upon the grain and bundle during their operation movements, and fall below the same to admit of the unobstructed movement of the grain and bundle over the surface of said platform.

The various instrumentalities constituting the binder mechanism are actuated by four shafts, I, K, L, M, arranged longitudinally of the machine, two above and two below the binder platform. One of said shafts I is supported in a bearing *b*² upon the bracket B², secured to the rear transverse sill A¹, and also by hangers *i* secured respectively to the transverse binder frame bars D² D³ D³, and extends longitudinally from the front to the rear of the machine. The front end of shaft I is provided with a sprocket pinion I¹, from which the reel, butter, and picker shafts are driven, as hereinafter described, and the rear end of said shaft I is provided with a sprocket wheel I², connected by a chain I³ with a sprocket wheel F⁹ secured to the end of a shaft F⁸ that serves to operate the carrier and the cutter bar, as above described.

The main binder shaft I is connected with and driven from the sprocket wheel shaft C³ by a bevelled pinion I¹ and bevelled gear I², shaft C³ being connected by a chain with the driving wheel axle, as above described.

The forward transverse binder-frame bar D² is firmly secured to the front end of the tubular bars D D¹, and upon its upper surface is firmly bolted to the tubular binder gear standard H¹, upon which the binding mechanism is mounted. This standard is made in an angular shape, the upright portion connecting the two arms, made by preference in the form of a hollow flattened half cylinder, or of a longitudinally flattened frustum of a cone, and from the upright portion two sleeves *h h*¹ extend horizontally, the former above the binder table and the latter below or underneath it, and secured to the bars D² D³ of the binder frame, said sleeve *h*¹ serving as the bearing for the shaft K, to the end of which the needle arm K¹ is attached, and the upper sleeve *h* serving as the bearing for the shaft M for actuating the knotting or band-uniting devices. A foot-board N, and picker rail J¹ are bolted together at right angles, one with the other, and are suspended from the main-gear standard by tie rods *n n l l*, in such manner that the foot-board will be arranged transversely, and the picker rail longitudinally of the machine, the rear end of the picker rail L¹ being upheld by a tie rod *l*¹ connecting it with the end of the knoter shaft M. A strut *n*¹ also connects the stubble end of the foot-board with the front sill A, or other portion of the main frame of the machine.

A reel post O is pivoted to the picker bar, near its point of union with the foot-board, by means of a stud pin *o*, and is adjustably connected by a bolt *o*¹ with a notched segment plate O², by which means said post may be swung so that a reel shaft O¹, suspended from its upper end, may be adjusted or placed at any desired position over, in front of, or in rear of the cutter bar. The reel shaft O¹ is journaled in a bearing

Improvements in Reaping and Binding Machines.

bearing o^2 , secured to a swinging strap o^3 pivoted at o^4 to the upper end of the reel post, and a worm actuated by a crank handle and journalled to the said strap o^3 engages with a segment rack plate o^5 , secured to the upper end of the reel post in such manner that the strap o^3 and shaft O^1 may be raised or lowered, and the reel or beaters secured to revolve at any required distance above the ground.

The reel shaft O^1 is revolved by a tumbling shaft O^6 , its ends being connected by an universal joint O^3 , and a gear wheel O^4 on said reel shaft is grooved or feathered to engage a bevel pinion O^5 on the upper end of the tumbling shaft, so that the pinion may slide upon and turn with said shaft, and the upper end of the tumbling shaft O^6 slides in a tubular bearing o^6 journalled by a sleeve upon the reel shaft O^1 , and the bearing o^6 is cast into a socket to enclose the pinion O^5 , and cause it to slide upon the shaft longitudinally when the shaft is adjusted. The teeth of the pinion O^5 and gear wheel O^4 are formed tangentially to an inner circle instead of radially to their respective shafts, in order that the tumbling shaft O^6 may cross the reel shaft O^1 at one side of its central line. By this arrangement of mechanism the reel is adapted to be driven in any of the various positions to which it may be adjusted, as above described.

The tumbling shaft O^6 is driven at its lower end by bevelled mitred gears $p^1 p^2$, connecting it with a short shaft P , which also drives the picker shaft L by gears $p^3 p^4$, and the butter shaft R^1 by gears $p^5 p^6$. To the end of shaft P is secured a sprocket wheel P^1 , connected by a chain P^2 with and driven from the main binder shaft I . By this means the pickers, butter, and reel shafts are driven by gearing, in advance of the binder gear and the line of cut, and are arranged above the moving grain.

The picker rail L^1 is supported horizontally above the lower end of the inclined binder table, as described, and has a series of brackets L^2 secured to and suspended from it. The picker shaft L is journalled in bearings in the above described brackets to revolve freely, and is provided with a number of crank arms $l^1 l^2$ set opposite each other, upon which are pivoted pendent picker teeth $L^3 L^4$, having their heel ends extended above the shaft L , and connected by links $l^3 l^4$ with lugs l^5 on the bar or rail L^1 . By this arrangement of pickers a movement in an elliptical path is given to the points of the pickers, and being operated in sets by cranks arranged for the purpose, one set is made to quickly follow another, and the grain is taken from the delivery end of the platform-carrier as rapidly as it reaches said end, and is pushed upward on the binder table, effectually preventing its dropping off the end of or following the return movement of the carrier. The picker teeth $L^3 L^4$ may be made flexible by placing a spiral spring l^6 around the links l^3 , to press against a collar l^7 arranged to slide upon the links l^3 , to which the upper end of the picker teeth may be pivoted. The yielding picker teeth will then be suited to tangled grain, and will not be obstructed in their movement by the grain becoming packed against the needle guard, while the bundle is being bound, as will hereinafter appear.

The butter mechanism is formed of an endless slatted apron R , that passes around rollers $R^1 R^2$, the lower one of which R^1 is journalled in bearings in the binder table, and is connected with the upper roller R^2 by frame pieces r at their upper and lower ends, so that the butter may be vibrated upon the roller at its lower end, to adjust the butter at any desired angle across the binder table, and across the line of movement of the grain. The upper end of the butter may thus be moved across the binder table, to approach more nearly to the centre line of movement of the grain upon the binder table, or away from said central line of movement, and thereby made to present the grain to the needle arm intermediately of its length, and can be readily adjusted to suit grain of various lengths. The adjustment of the vibrating butter frame is effected by means of the foot lever R^3 pivoted to the binder frame, and provided with toothed rack r^1 , that engages with a pin or strap r^2 secured to the foot-board, so that the bent or forward end of the lever is within convenient reach of the driver from his seat. The butter above described not only serves to even up the butts and present the grain properly to the binder arm, but materially aids in raising the butt ends of the grain up the inclined binder table within reach of the packers.

The needle arm K^1 is secured to its shaft K , and is oscillated at suitable intervals, as hereinafter described, and is provided with a guard K^2 that extends from the point of the needle to the lower part of the binder platform, and serves to cut off the grain from the action of the packers when the needle is raised and while the bundle is being bound.

The main binder gear shaft I is provided with arms s s about the centre of its length, through which motion is imparted to the packers S S , which are suspended by links $s^1 s^2$ from the transverse binder frame pieces. The packers receive a continuous motion from the main binder shaft, and their points pass through elliptical paths in the direction of the upward inclination of the table, and arranged so that their direct or upward movement shall be above the plane of the table, and their retracting movement will be in a path underneath the said binder table. Transverse slots in said table permit the pickers to move freely through them. The position of the cranks upon the main binder shaft is such, with relation to each other, that while one packer is moving above the table to raise the grain the other packer is moved back beneath the table to reach the grain near the foot of the incline, and thus raise and pack it against a compressor T pivoted to a lug upon the hub of a needle arm K^1 , and arranged to be raised above the binder table to intercept the flow of the grain. The compressor T is both raised above the table and drawn beneath the same by a bell crank lever t , secured to a rock shaft T^1 supported in bearings upon the binder frame. The lever t is connected by a link t^1 with the compressor T , and the shaft T^1 is formed with a crank arm t^2 upon its forward end that is connected by a flexible link T^2 with a rocking lever t^3 pivoted to the gear standard H . The rocking lever t^3 is provided with a friction roller upon its free end, which moves in a groove in the face of the gear wheel on the forward end of the knotter shaft M , and rocks the lever t^3 by drawing its free end towards and forcing it away from said shaft M . The groove has an inner and an outer still or concentric portion, which gives a period of rest to the compressor, both in its raised and in its depressed position, which is required during the revolution of the knotter shaft, while the knot is being tied, and subsequently while the bundle is being delivered and ejected.

The flexible link is formed by rods coupled with a spiral spring interposed between them of sufficient strength to hold the rock shaft T^1 under the ordinary pressure of the compressor, but which will yield when strain is brought upon it and permit the compressor to give away to accommodate itself to a larger bundle. It will be seen that the compressor T is supported in its raised position by the link t^1 , and when the needle arm is raised to its full height, the lug k of the needle arm will tilt its compressor, and give

Improvements in Reaping and Binding Machines.

give to it a final pressure upon the gavel, while the knot is being tied. A trigger T^3 is pivoted to the compressor T , to project in front of it and intercept the grain before it is forced against the compressor. The trigger is provided with an arm t^2 , formed with an eye in its end, through which an arm t^1 of a rock shaft T^1 passes. The rock shaft T^1 is supported in bearings beneath the binder table, and extends longitudinally of the machine to the front of the binder-gear standard, at which end is secured a short arm t^1 that presses against a detent lever k^2 journalled upon the forward end of the binder arm shaft, and lifts it out of contact with a clutch lever k^3 that connects the continuously revolving main binder shaft I with the train of gears U, U^1, U^2, U^3 , which set in motion the binder mechanism. The detent lever k^2 is connected to an arm K^3 on the forward end of the needle shaft by a spring link k^4 , which holds the lever k^2 in position to trip the clutch lever k^3 ordinarily, and release the lower gear pinion U from the main binder shaft, so that said shaft may revolve independently of the binder gearing, until a sufficient quantity of grain has been packed against the trigger T^3 to force it back and start the binder mechanism, as above described. The rock shaft T^1 has secured to its forward end a rod or foot lever T^5 within reach of the driver from his seat, by which means the rock shaft T^1 with its arm t^1 may be operated from the driver's seat to start the binder mechanism, should the trigger and automatic trip fail to operate.

The binder gearing and knotter mechanism is similar to the well known Appleby binder, and besides the tripping mechanism above described, consists of a rock arm K , secured to the forward end of the needle bar shaft that is connected by a rod k^5 with a pin on the face of the gear wheel U^3 upon the forward end of the knotter shaft M , by which means one complete revolution of the knotter shaft will cause a single oscillation of the needle arm and its shaft.

The rear end of the knotter shaft is provided with delivery arms M^2 , that revolve with it and serve to raise the bundle after it has been bound to within reach of an ejector arm W , pivoted to the upper end of and beneath the inclined binder platform. The ejector arm W is connected by a link w , with the bell-crank lever t or rock shaft T^1 , in such manner that the ejector is raised to lift the bundle over the wheel when the compressor and binding mechanism are brought to their position of rest. A breast-plate V is secured by braces v , in brackets v^1 to the overhung arm h of the gear standard, and extends down and is secured to the picker rail L^1 to form a shield above the grain to hold it down upon the binder table while being elevated and bound.

An apron W^1 , composed of metal plate, curved above the drive wheel, and an inclined board w^2 secured to the upper end of the inclined binder table, serves to protect the wheel and driving gear, and facilitates the discharge of the bundle over the wheel. A shield W^2 of sheet metal covers the ends of the shafts and gearings for operating the butter, reel, and pickers, and is secured to the stubble side divider W^3 and also to the picker rail.

A leaf or head-board X is hinged to the rear transverse rail A^1 , and may be held in an upright position by hook x , connecting it with the grain board or frame, and metal hinge brackets x^1 , secured to the transverse rail A^1 , will serve to hold the head-board in an inclined position at the rear of the machine, upon which the heads of long grain may be supported as they are carried across the platform of the machine. The driver's seat Y is supported above the drive wheel on the stubble side of the binder platform upon an inclined arm secured to the upper arm h^1 of the main gear standard, and also to the picker rail.

The tongue is pivoted to the bracket B^1 , as described, and is connected by a link z with the short arm of a hand lever Z pivoted to a segment rack plate Z^1 , bolted to the foot-board of the machine. A spring bolt z^2 connects the lever and rack, by which means the lever may be adjusted upon it to raise or lower the tongue and tilt the machine.

The drive wheel and grain wheel are constructed in a peculiar manner, whereby said wheels may be detachable from the rim or fellics, and made adjustable thereon, so that when from any cause it becomes necessary to remove the hub and its spokes from such rim, or to tighten the attachment of the spokes to said rim, it may be easily and quickly accomplished. The hub and spokes are cast in one piece. Clips c are secured to the inner surface of the rim, and are formed with parallel flanges $c^1 c^1$, united by a cross web c^2 , and the base of the clips between the flanges and the web is an incline c^3 extending from the edge of the clip and rising towards the transverse web. The spokes c^4 of the wheel are bevelled on their outer ends to conform to the inclination of the inclined floor of the clip, so that they may ride up said incline as the wheel is revolved and tighten themselves within the tire. Bolts c^5 pass through the ends of the spokes and also through the web of the clips, and hold the spokes securely to the clip, and also to the rim of the wheel.

By tightening the bolts and nuts the spokes may be forced closely into their seats upon the clips, and all looseness taken up between the rim and its spokes.

By the general arrangement of parts above described the machine is brought into compact form, utilizing the space required for elevating the grain over the wheel, for binding the same, and saving the space ordinarily occupied by binding mechanism outside of said wheel. The various instrumentalities, viz., the pickers, packers, and needle arm, not only serve to gather and compress and bind the grain, but elevate it progressively until the bundle is completely bound and ejected over the drive wheel and away from the machine.

The needle arm not only serves to gather the grain into a compact gavel for binding it, but in doing so carries it up the inclined binder table towards its point of discharge.

By arranging the main binder gear standard at the front end of the machine, and supporting the binder gearings and framing arranged above the platform from its front end only, the grain and bundle will have a free and unobstructed path over the binder platform.

By the several arrangements of adjusting devices above described the height of the frame, the angle of inclination of the same, and of the platform and cutters, and the position of the reel and butter are all placed under the control of the driver in his seat, and he is enabled to adapt the machine easily and quickly to the conditions of the grain to be operated upon, while the binder tripping mechanism is equally well under command of the driver to be operated upon by his foot, should the automatic mechanism fail to work from any cause.

Having

Improvements in Reaping and Binding Machines.

Having now described my invention, what I claim as new is, viz. :—

- First—The inclined binder frame interposed between the main drive wheel and the cutting apparatus and platform, one of the inclined transverse bars of said frame being provided with a pendent arm supporting the main drive wheel axle.
- Second—The combination with the platform sill or frame of the brackets B B', the inclined binder frame secured to said sill and brackets, the angular axle bracket B⁴ and the brace A⁴, all substantially as described.
- Third—The combination of the packers S, suspended by links s¹ from the transverse frame, and operated by the cranks s on the shaft I, with the inclined binder table and its supporting frame, substantially as herein described and explained, and as illustrated in the drawings.
- Fourth—The combination of the needle arm K¹ having guard K² thereon, and secured to shaft K working in lower sleeve h¹, with the inclined binder table and its supporting frame, substantially as herein described and explained, and as herein illustrated in the drawings.
- Fifth—The combination of the compressor arm T with the trigger T³, and operating mechanism with the inclined binder table and its supporting frame, substantially as herein described and explained, and as illustrated in the drawings.
- Sixth—The combination of the pivoted ejector arm W and its operating mechanism with the inclined binder table, and its supporting frame, substantially as herein described and explained, and as illustrated in the drawings.
- Seventh—The combination of the standard H, its horizontal sleeve h for supporting knotting shaft M, at the desired position with the inclined binder table, and its supporting frame, substantially as herein described and explained, and as illustrated in the drawings.
- Eighth—The combination of the pickers L³, shaft L, brackets L², picker rail L¹, and the picker operating mechanism with the inclined binder table and its supporting frame, substantially as herein described and explained, and as illustrated in the drawings.
- Ninth—The combination of the adjustable butter and its locking mechanism, formed of the parts marked R, R¹, R², R³, r, r¹, r², and operated by the bevel gear p⁴ and p⁵ on shaft P, with inclined binder table and its supporting frame, substantially as herein described and explained, and as illustrated in the drawings.
- Tenth—The combination of the parts marked O to O⁶, and o to o⁶, forming the adjustable reel-post and its tumbler shaft, substantially as herein described and explained, and as illustrated in the drawings.
- Eleventh—The combination of the parts for adjustably attaching the drive wheel C to the frame of the machine, consisting of the segmental slotted bracket B, its sleeve C², and the curved extension for the transverse bar D³, substantially as herein described, and as illustrated in the drawings.
- Twelfth—The combination of the parts for adjustably attaching the grain wheel F to the frame of the machine, consisting of the quadrant lever T¹, and its stud axle f, substantially as herein described and explained, and as illustrated in the drawings.
- Thirteenth—The mechanism attached to the machine, and employed for raising and lowering its height from the ground, and consisting of the parts marked E to E⁴, e to e², and chain F², in combination with the parts mentioned in the two preceding claims, as and for the purposes herein described and explained, and as illustrated in the drawings.
- Fourteenth—The combination of parts transmitting motion to the main binder shaft I from the drive wheel C, consisting of the sprocket wheel C¹, chain J, sprocket wheel C³, shaft C³, and bevel gear I² and I⁴, substantially as herein described and explained, and as illustrated in the drawings.
- Fifteenth—The combination of parts for transmitting motion to the cutter bar F¹ and travelling table G² from said shaft I, consisting of the sprocket wheel I², chain I³, sprocket wheel F⁴, shaft F, the crank arm f², pitman F⁵, joint f¹, swing lever F⁶, and its longitudinal support F⁶, substantially as herein described and explained, and as illustrated in the drawings.
- Sixteenth—The combination of the mechanical parts for conveying motion to the reel butter and picker shafts from said shaft I, consisting of the sprocket wheel I¹, chain P², sprocket wheel P¹, shaft P, bevel gear p and p¹, and gear wheels p³ and p³, substantially as herein described and explained, and as illustrated in the drawings.
- Seventeenth—The combination of the mechanical parts for conveying motion to the knotted shaft M from said shaft I, consisting mainly of the train of wheels U to U³ with the connecting rod K⁴, for oscillating the needle arm and its shaft K, substantially as herein described and explained, and as illustrated in the drawings.
- Eighteenth—The combination of the shaft M and its delivery arm M³ with the ejector arm W and the inclined binder platform, substantially as and for the purpose herein described and explained.
- Nineteenth—The combination of the mechanical parts for giving the rocking motion to the rock shaft T from the upper gear wheel U, and from thence to the compressor T and the ejector arm W, substantially as herein described and explained, and as illustrated in the drawings.
- Twentieth—The continuation of the mechanical parts for giving the necessary motion to the shaft T¹, which operates the trigger gear T³, pivoted to the compressor arm T, substantially as herein described and explained, and as illustrated in the drawings.

Twenty-first—

Improvements in Reaping and Binding Machines.

Twenty-first—The special construction of the arm and grain wheels, the spokes and hub of which are made in one part, and are affixed to the rim by the devices marked from C to C^s, substantially as herein described and explained, and as illustrated more particularly in figures 5 to 13 of the drawings.

In witness whereof, I, the said Lewis Miller, have hereto set my hand and seal.

LEWIS MILLER.

(By his Agent, EDWARD WATERS.)

Witness—

FRED WALSH.

This is the amended specification marked A referred to in the annexed Letters of Registration granted to Lewis Miller, the seventeenth day of December, A.D. 1884.

AUGUSTUS LOFTUS.

REPORTS.

Sir,

Sydney, 11 September, 1884.

With reference to your B.C. communication, dated the 30th ultimo, covering a petition from Mr. Lewis Miller for Letters of Registration for an invention entitled "Improvements in Reaping and Binding Machines," we do ourselves the honor to report that, having examined the plans, specification, and claims, we are unable to recommend the prayer of the Petitioner, owing to the diffuse and prolix nature of his claim, which includes ordinary appliances not entitled to registration.

We have, &c.,

EDMUND FOSBERY.
GOTHEK K. MANN.

The Under Secretary of Justice.

Sir,

Sydney, 31 October, 1884.

We do ourselves the honor to report, in reply to your B.C. of the 15th instant, that as Mr. Lewis Miller's revised specification for the registration of "Improvements in Reaping and Binding Machines" now explicitly confines his claim to combination and general arrangement, and does not include any of its component parts, all of which appear to be more or less appliances already in use, we are of opinion that the prayer of the petition may now be granted.

We have, &c.,

EDMUND FOSBERY.
GOTHEK K. MANN.

The Under Secretary of Justice.

[Drawings—three sheets.]

This is the Sheet of Drawings marked D entered in the
Mines, the seventh day of December, A. D. 1884.
Augustus Lukius.

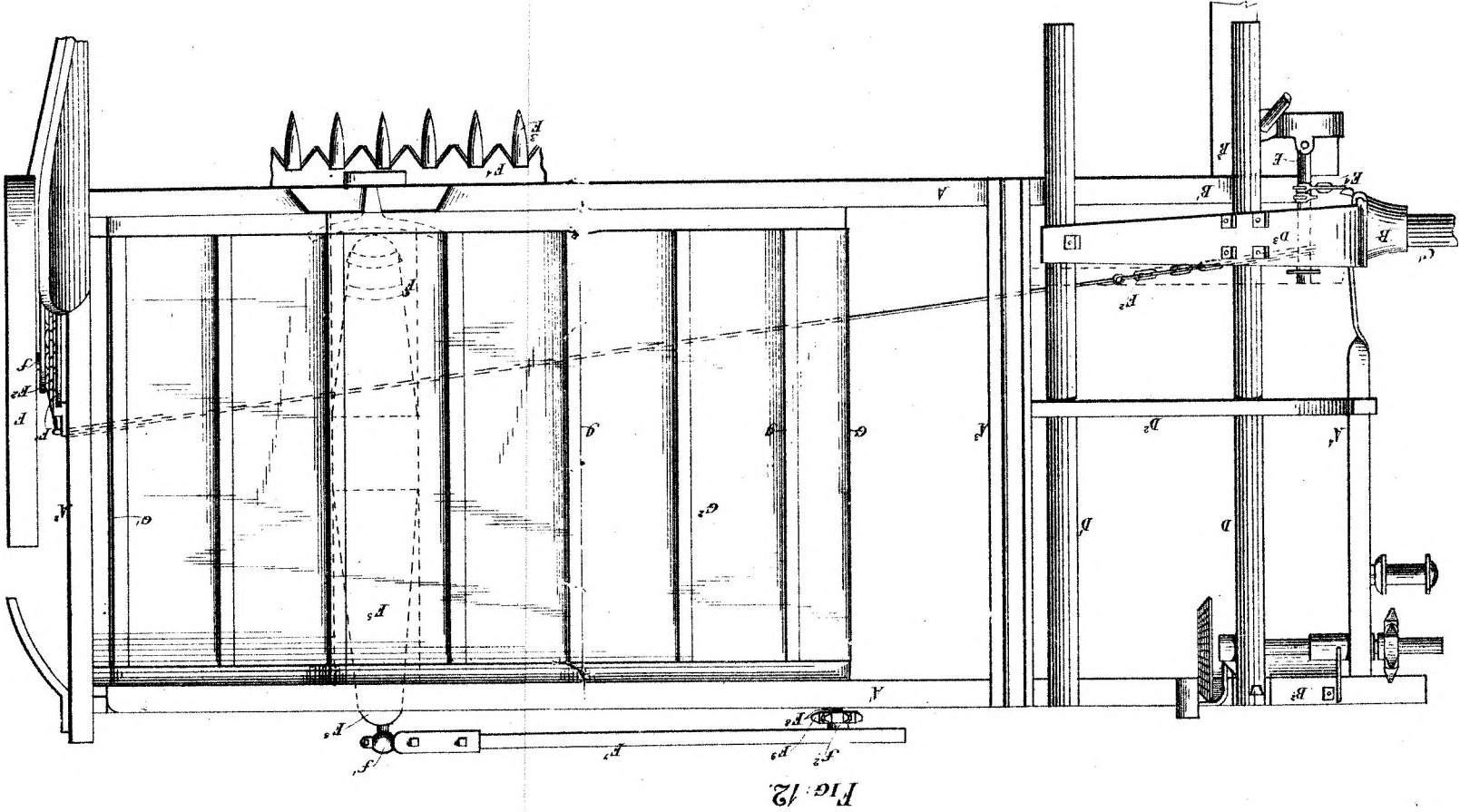
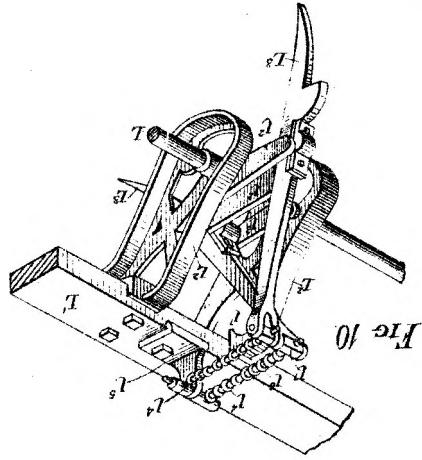
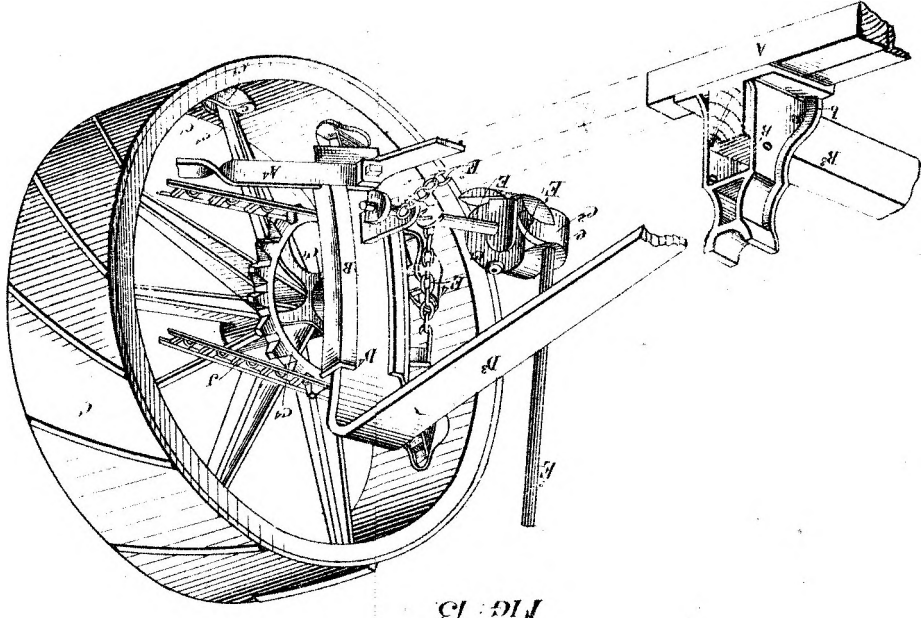
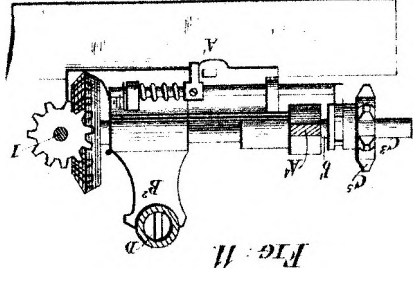


Fig. 12

Fig. 13



A.D. 1884, 17th December. No. 1544.

AN IMPROVED APPARATUS FOR HEATING WATER.

LETTERS OF REGISTRATION to Edward Joseph Douglas, for an Improved Apparatus for Heating Water.

[Registered on the 18th day of December, 1884, in pursuance of the Act 16 Vic: No. 24.]

BY HIS EXCELLENCY THE RIGHT HONORABLE SIR AUGUSTUS WILLIAM FREDERICK SPENCER LOFTUS (commonly called LORD AUGUSTUS LOFTUS), Knight Grand Cross of the Most Honorable Order of the Bath, a Member of Her Majesty's Most Honorable Privy Council, Governor and Commander-in-Chief of the Colony of New South Wales and its Dependencies.

TO ALL TO WHOM THESE PRESENTS SHALL COME, greeting :

WHEREAS EDWARD JOSEPH DOUGLAS, of 100, Collins-street East, in the city of Melbourne and Colony of Victoria, brassfounder, hath by his Petition humbly represented to me that he is the author or designer of a certain invention or improvement in manufactures, that is to say, of an invention entitled "An Improved Apparatus for Heating Water," which is more particularly described in the specification and the sheet of drawings which are hereunto annexed ; and that he, the said Petitioner, hath deposited with the Honorable the Treasurer of the said Colony of New South Wales the sum of Twenty Pounds sterling, for defraying the expense of granting these Letters of Registration, as required by the Act of Council, sixteenth Victoria, number twenty-four ; and hath humbly prayed that I would be pleased to grant Letters of Registration whereby the exclusive enjoyment and advantage of the said invention or improvement might be secured to him for a period of fourteen years : And I, being willing to give encouragement to all inventions and improvements in the arts or manufactures which may be for the public good, and having received a report favourable to the prayer of the said Petition, from competent persons appointed by me to examine and consider the matters stated therein and to report thereon for my information, am pleased, with the advice of the Executive Council, and in exercise of the power and authority given to me by the said Act of Council, to grant, and do by these Letters of Registration grant unto the said Edward Joseph Douglas, his executors, administrators, and assigns, the exclusive enjoyment and advantage of the said invention or improvement for and during the term of fourteen years from the date hereof ; to have, hold, and exercise unto the said Edward Joseph Douglas, his executors, administrators, and assigns, the exclusive enjoyment and advantage thereof, for and during and unto the full end and term of fourteen years from the date of these presents next and immediately ensuing, and fully to be complete and ended : Provided always, that if the said Edward Joseph Douglas shall not, within three days after the granting of these Letters of Registration, register the same in the proper office in the Supreme Court, at Sydney, in the said Colony of New South Wales, then these Letters of Registration, and all advantages whatsoever hereby granted, shall cease and become void.

In witness whereof, I have hereunto set my sign manual, and have caused the present Letters of Registration to be sealed with the seal of the said Colony of New South Wales, at Government House, Sydney, in New South Wales, this seventeenth day of December, in the year of our Lord one thousand eight hundred and eighty-four.

[L.S.]

AUGUSTUS LOFTUS.

An Improved Apparatus for Heating Water.

SPECIFICATION.

TO ALL TO WHOM THESE PRESENTS SHALL COME, I, EDWARD JOSEPH DOUGLAS, of 100, Collins-street East, in the city of Melbourne and colony of Victoria, brassfounder, send greeting :

WHEREAS I am desirous of obtaining Royal Letters Patent for securing unto me Her Majesty's special license, that I, my executors, administrators, and assigns, and such others as I or they should at any time agree with, and no others, should and lawfully, might from time to time, and at all times during the term of fourteen years (to be computed from the day on which the original specification in this matter was deposited at the office of the Registrar-General, namely, the third day of November, one thousand eight hundred and eighty-four, make, use, exercise, and vend within the Colony of New South Wales and its dependencies an invention for an improved apparatus for heating water, and in order to obtain the said Letters Patent, I must, by an instrument in writing under my hand and seal, particularly describe and ascertain the nature of the said invention, and in what manner the same is to be performed, and must also enter into the covenant hereinafter contained. Now know ye that the nature of the said invention, and the manner in which the same is to be performed, is particularly described and ascertained in and by the following statement, that is to say—

My improved apparatus for heating water, mainly of an inner and an outer casing, the latter approximately in shape to that of the former.

The space enclosed by the inner casing forms a heat-chamber, the heat in which is produced by the combustion of gas ; the water is heated by passing in a thin sheet or layer over the outer surface of this heat-chamber ; the bottom of this inner chamber is enlarged very considerably, and by preference is circular in plan, the bottom of it being formed by a main gas-pipe, supplying smaller cross gas-pipes, from the perforations in which issue gas jets ; from the centre of the top of this enlarged part there proceeds a tapering continuation into a large chamber, from whence proceeds a flue to convey away the foul gasses.

The water to be heated is carried by a copper pipe into the inner chamber, and ascends about 12 inches ; the tube is then bent into a coil, which forms a rest for the asbestos ; it then ascends to the top of the flue, where a perforated ring is screwed on to convey the water down the outside of the flue into the top and enlarged chamber, around which it is conducted and conveyed to the top of the tapering continuation, down the sides of which it passes over the top of the enlargement, and is finally discharged at the bottom heated for use. I place a thermometer at the point of discharge by which I am enabled to tell not only the temperature of the water discharged, but also whether the flame is too great or too little.

Referring to my drawings, fig. 1, 2, and 3 show respectively vertical section elevation and plan of top portion of my improved apparatus for heating water, fig. 4, section at *a . . . a . . .*, figs. 1 and 2 and fig. 5 section at *b . . . b . . .*, figs. 1 and 2 showing plan and arrangement of gas jets. The dotted lines in drawing shows the water descending from the perforated ring. A is the outer casing of my machine, E is the cold-water supply pipe, and D the hot-water discharge pipe.

E is the main gas-pipe. The top of the inner casing B terminates in a neck, B¹, leading into an enlarged chamber B², from which proceeds flue B³ ; the bottom B⁴ of the inner casing is also enlarged as shown. B⁵ is the copper pipe bent into a coil, on which is placed asbestos or other incombustible material. B⁶ is a dish, D is a thermometer, E¹ are branches from the main gas-pipe, and E² is a small pipe attached to tap E³, and having a burner ; at the end E⁴ is a slit in outer casing for such pipe to pass in and light the other jets.

The mode of operation is as follows :—The jet at end of pipe E² is first lighted and then swung through the slit E⁴ in close proximity with the inside jets, which it lights ; the cold water is then turned on, and as it passes through the inner chamber, as shown in drawing, it obtains a partial heat before discharging itself down the flue on to the crown of enlarged chamber B² ; it is then conducted by dish B⁶ to bottom of neck B¹, from whence it passes in a thin film over the whole of the outer surface of inner casing B, being gradually heated as it descends, and is finally discharged through the hot-water pipe D. The asbestos fire has the effect of retaining the heat and preserving a higher temperature in the upper portion of inner casing B than would be otherwise obtainable with the same expenditure of gas.

The object of enlarging the bottom of the inner casing B is to increase the heating surface where the heat is greatest, so as to cause the water to pass over this part in a thinner film, and so to enable it the more readily to increase in temperature ; this I find of great advantage.

Having thus described the nature of my invention and the manner of performing same, I would have it understood that I do not claim broadly the heating of water in thin films over heated surfaces, nor the use of gas for the purpose, nor the making of such contrivances portable, but what I believe to be new in my improved apparatus for heating water is :—

First—The introduction of a fire of incombustible materials, such as asbestos, into a chamber heated by gas, and substantially in the form and manner shown.

Second—The arrangement of burners in the manner shown in fig. 5.

Third—The enlargement of the bottom of the inner casing B at B¹ for the purpose of increasing the heating surface, where the greatest heat is being given out, substantially as herein described and explained.

Fourth—The manner in which the water is carried through the inner casing by the copper pipe in the shape of a coil, which forms a rest for the asbestos, and then ascends to the perforated ring ; by this manner the water is partially heated in ascending, and also in descending the outside of flue before it is brought into contact with heated surfaces of the inner chamber.

And

An Improved Apparatus for Heating Water.

And I do hereby for myself, my heirs, executors, and administrators, covenant with Her Majesty, her heirs and successors, that I believe the same invention to be a new invention as to the public use and exercise thereof, and that I do not know or believe that any other person than myself is the true and first inventor of the said invention, and that I will not deposit these presents at the office of the Registrar-General with any such knowledge or belief as last aforesaid.

In witness whereof, I, the said Edward Joseph Douglas, have hereto set my hand and seal.

E. J. DOUGLAS.

This is the specification referred to in the annexed Letters of Registration granted to Edward Joseph Douglas, the 17th day of December, A.D. 1884.

AUGUSTUS LOFTUS.

REPORT.

Sir,

In the matter of the application of Mr. Edward J. Douglas for Letters of Registration for an "Improved Apparatus for Heating Water," which has been referred to us, we have examined the specification and drawings accompanying the same, and have now the honor to report that we see no objection to the issue of Letters of Registration as prayed for.

Sydney, 8 November, 1884.

We have, &c.,
J. SMITH.
A. LEIBIUS.

The Under Secretary of Justice.

[Drawings—one sheet.]

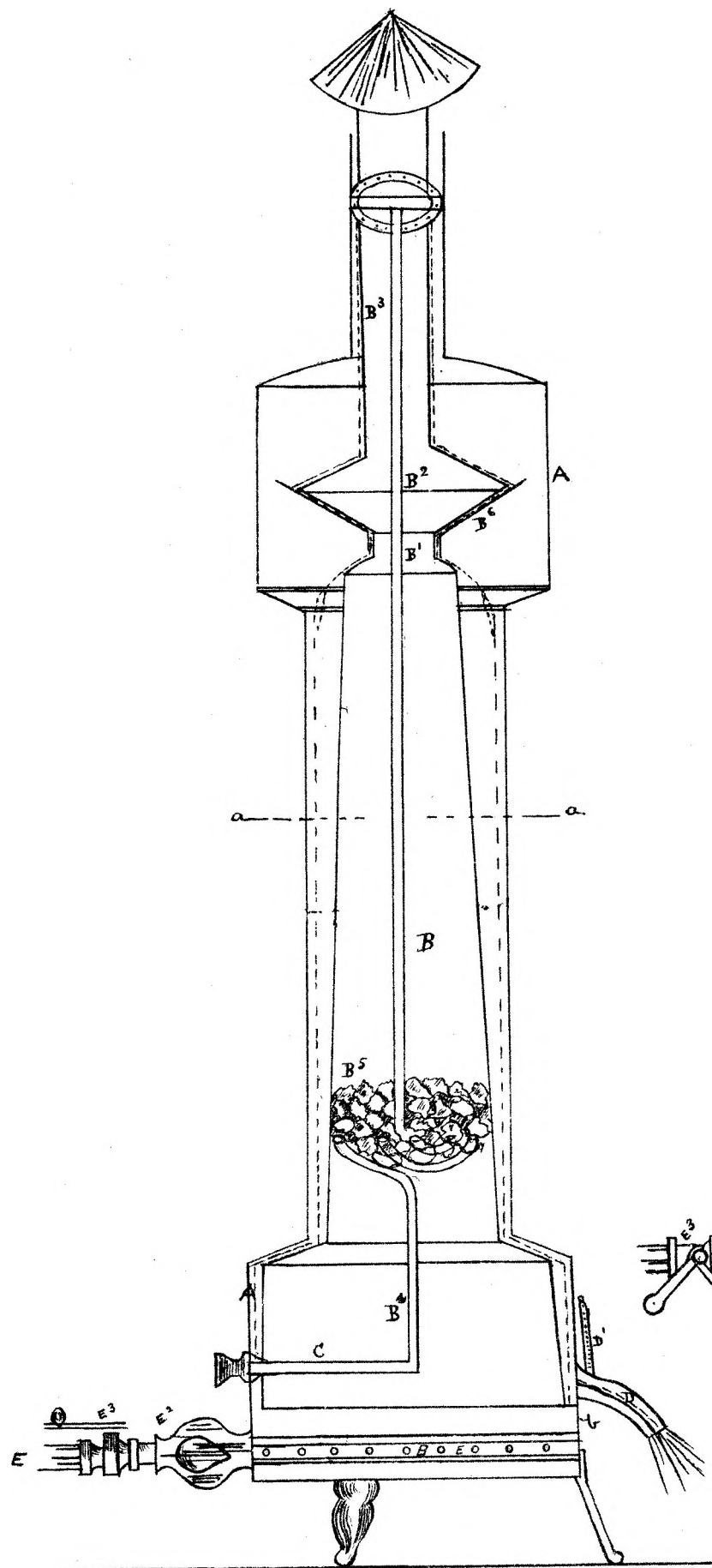


FIG. 1

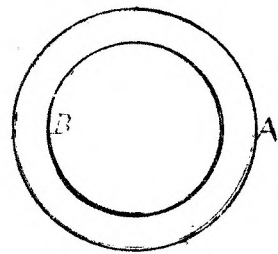


FIG. 4

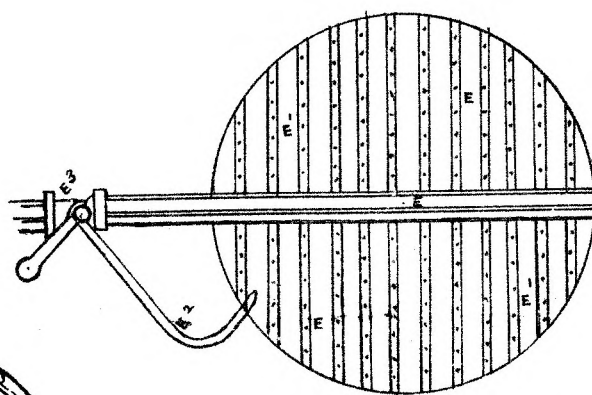


FIG. 5.

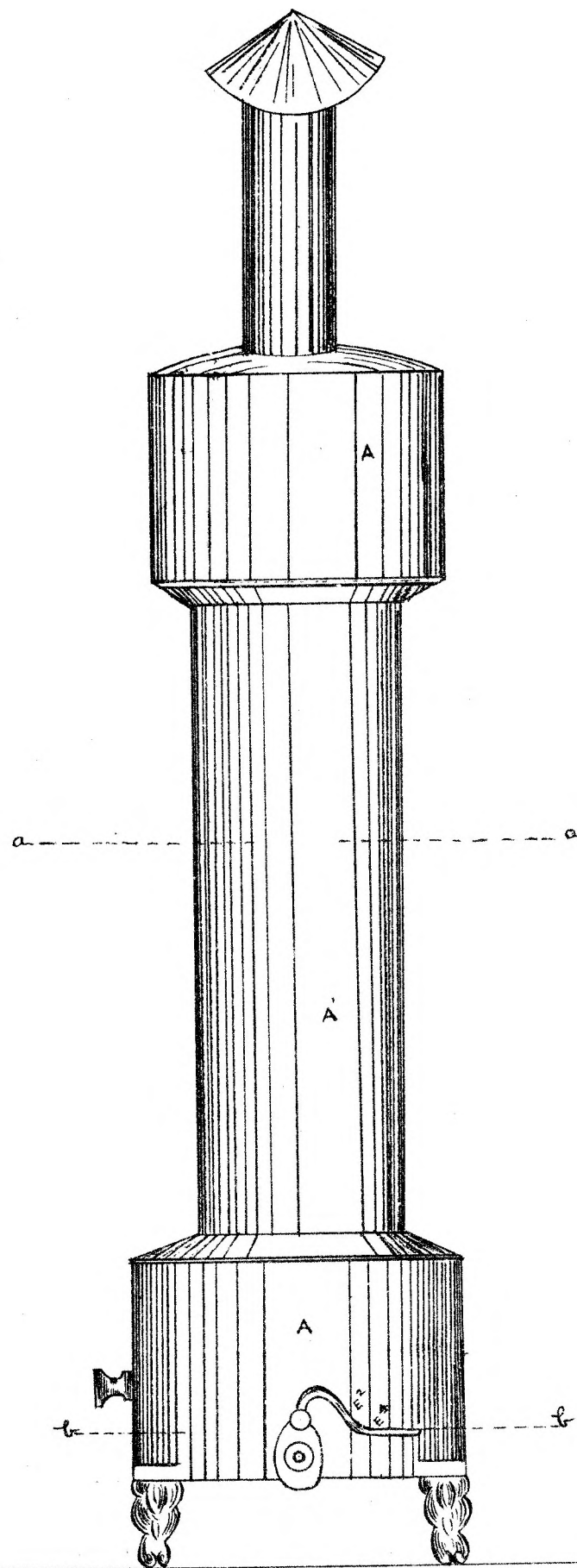


FIG. 2

(Sig 245~)

*This is the Sheet of Drawings referred to in the annexed
 Letters of Registration granted to Edward Joseph
 Douglas, the seventeenth day of December AD. 1884.
 Augustus Loftus.*

PHOTO-LITHOGRAPHED AT THE GOVT. PRINTING OFFICE,
 SYDNEY, NEW SOUTH WALES.



A.D. 1884, 17th December. No. 1545.

IMPROVEMENTS IN THE USE OF CHLORIDE OF LIME FOR THE PURPOSES OF
DISINFECTION AND DEODORIZATION.

LETTERS OF REGISTRATION to Josiah Vincent Lavers, for Improvements in
the use of Chloride of Lime for the purposes of Disinfection and Deodorization.

[Registered on the 18th day of December, 1884, in pursuance of the Act 16 Vic. No. 24.]

BY HIS EXCELLENCY THE RIGHT HONORABLE SIR AUGUSTUS WILLIAM FREDERICK SPENCER LOFTUS
(commonly called LORD AUGUSTUS LOFTUS), Knight Grand Cross of the Most Honorable Order of
the Bath, a Member of Her Majesty's Most Honorable Privy Council, Governor and Commander-in-
Chief of the Colony of New South Wales and its Dependencies.

TO ALL TO WHOM THESE PRESENTS SHALL COME, greeting :

WHEREAS JOSIAH VINCENT LAVERS, of 117, Redfern-street, Redfern, in the Colony of New South Wales, hath by his Petition humbly represented to me that he is the author or designer of a certain invention or improvement in manufactures, that is to say, of an invention entitled "Improvements in the use of Chloride of Lime for the purposes of Disinfection and Deodorization," which is more particularly described in the specification which is hereunto annexed; and that he, the said Petitioner, hath deposited with the Honorable the Treasurer of the said Colony of New South Wales the sum of Twenty Pounds sterling, for defraying the expense of granting these Letters of Registration, as required by the Act of Council, sixteenth Victoria, number twenty-four; and hath humbly prayed that I would be pleased to grant Letters of Registration, whereby the exclusive enjoyment and advantage of the said invention or improvement might be secured to him for a period of fourteen years: And I, being willing to give encouragement to all inventions and improvements in the arts or manufactures which may be for the public good, and having received a report favourable to the prayer of the said Petition, from competent persons appointed by me to examine and consider the matters stated therein, and to report thereon for my information, am pleased, with the advice of the Executive Council, and in exercise of the power and authority given to me by the said Act of Council, to grant, and do by these Letters of Registration grant unto the said Josiah Vincent Lavers, his executors, administrators, and assigns, the exclusive enjoyment and advantage of the said invention or improvement, for and during the term of fourteen years from the date hereof; to have, hold, and exercise unto the said Josiah Vincent Lavers, his executors, administrators, and assigns, the exclusive enjoyment and advantage thereof, for and during and unto the full end and term of fourteen years from the date of these presents next and immediately ensuing, and fully to be complete and ended: Provided always, that if the said Josiah Vincent Lavers shall not, within three days after the granting of these Letters of Registration, register the same in the proper office in the Supreme Court, at Sydney, in the said Colony of New South Wales, then these Letters of Registration, and all advantages whatsoever hereby granted, shall cease and become void.

In witness whereof, I have hereunto set my sign manual, and have caused the present Letters of Registration to be sealed with the seal of the said Colony of New South Wales, at Government House, Sydney, in New South Wales, this seventeenth day of December, in the year of our Lord one thousand eight hundred and eighty-four.

[L.S.]

AUGUSTUS LOFTUS.

Improvements in the use of Chloride of Lime, &c.

SPECIFICATION of JOSIAH VINCENT LAYERS, of 117, Redfern-street, Redfern, in the Colony of New South Wales, gentleman, of an invention entitled, "Improvements in the use of Chloride of Lime for the purposes of Disinfection and Deodorization."

THE object of this invention is to facilitate the elimination of chlorine gas from chloride of lime, by means of desiccated powders added to it, thereby rendering it friable, and capable of being shaken out of vessels containing perforated holes or otherwise.

I take the chloride of lime in as dry a state as possible, and mix it with about one-fourth of its weight of powdered alum, to which mixture I add sand or other silicious powder, in the proportion of about one-half the weight of the latter materials to the combined weight of chloride of lime and alum. The powder so mixed is placed in vessels containing perforated holes, and hermetically sealed to prevent deliquescence.

I claim as my invention—

1st—The addition to chloride of lime of alum, or any other powder which will disengage the chlorine gas; and

2nd—The addition of silicate or other friable matter to render chloride of lime capable of being freely discharged or shaken out as aforesaid, but I do not confine myself to any exact proportions of the ingredients named.

Redfern, 24th October, 1884.

J. V. LAYERS.

This is the specification referred to in the annexed Letters of Registration granted to Josiah Vincent Lavers the seventeenth day of December, A.D. 1884.

AUGUSTUS LOFTUS.

REPORT.

Sir,

Sydney, 6 November, 1884.

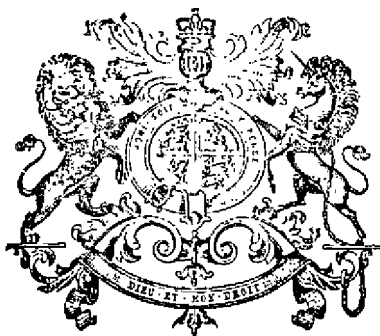
The application of Mr. J. Lavers for Letters of Registration for "Improvements in the use of Chloride of Lime for the purpose of disinfection, &c.," having been referred to us, we have examined the specification accompanying the same, and have now the honor to report that we see no objection to the issue of Letters of Registration as prayed for.

We have, &c.,

J. SMITH.

A. LEIBIUS.

The Under Secretary of Justice.



A.D. 1884, 17th December. No. 1546.

IMPROVED COMPOSITION OF MATERIALS CALLED "TERRA-COTTA TIMBER."

LETTERS OF REGISTRATION to Charles Carroll Gilman, for an invention entitled "An improved Composition of Materials called 'Terra-cotta Timber.'"

[Registered on the 18th day of December, 1884, in pursuance of the Act 16 Vic. No. 24.]

BY HIS EXCELLENCY THE RIGHT HONORABLE SIR AUGUSTUS WILLIAM FREDERICK SPENCER LOFTUS (commonly called LORD AUGUSTUS LOFTUS), Knight Grand Cross of the Most Honorable Order of the Bath, a Member of Her Majesty's Most Honorable Privy Council, Governor and Commander-in-Chief of the Colony of New South Wales and its Dependencies.

TO ALL TO WHOM THESE PRESENTS SHALL COME, greeting :

WHEREAS CHARLES CARROLL GILMAN, of Eldora, in the State of Iowa, one of the United States of America, hath by his Petition humbly represented to me that he is the author or designer of a certain invention or improvement in manufactures, that is to say, of an invention entitled "An improved composition of materials called 'Terra-cotta Timber,'" which is more particularly described in the specification which is hereunto annexed; and that he, the said Petitioner, hath deposited with the Honorable the Treasurer of the said Colony of New South Wales the sum of Twenty Pounds sterling, for defraying the expense of granting these Letters of Registration, as required by the Act of Council, sixteenth Victoria, number twenty-four; and hath humbly prayed that I would be pleased to grant Letters of Registration, whereby the exclusive enjoyment and advantage of the said invention or improvement might be secured to him for a period of fourteen years: And I, being willing to give encouragement to all inventions and improvements in the arts or manufactures which may be for the public good, and having received a report favourable to the prayer of the said Petition, from competent persons appointed by me to examine and consider the matters stated therein and to report thereon for my information, am pleased, with the advice of the Executive Council, and in exercise of the power and authority given to me by the said Act of Council, to grant, and do by these Letters of Registration grant unto the said Charles Carroll Gilman, his executors, administrators, and assigns, the exclusive enjoyment and advantage of the said invention or improvement, for and during the term of fourteen years from the date hereof; to have, hold, and exercise unto the said Charles Carroll Gilman, his executors, administrators, and assigns, the exclusive enjoyment and advantage thereof, for and during and unto the full end and term of fourteen years from the date of these presents next and immediately ensuing, and fully to be complete and ended: Provided always, that if the said Charles Carroll Gilman shall not, within three days after the granting of these Letters of Registration, register the same in the proper office in the Supreme Court, at Sydney, in the said Colony of New South Wales, then these Letters of Registration, and all advantages whatsoever hereby granted, shall cease and become void.

In witness whereof, I have hereunto set my sign manual, and have caused the present Letters of Registration to be sealed with the seal of the said Colony of New South Wales, at Government House, Sydney, in New South Wales, this seventeenth day of December, in the year of our Lord one thousand eight hundred and eighty-four.

[L.S.]

AUGUSTUS LOFTUS.

Improved Composition of Materials called "Terra-cotta Timber."

SPECIFICATION of CHARLES CARROLL GILMAN, of Eldora, in the State of Iowa, one of the United States of America, for an invention entitled "An improved composition of materials called 'Terra-cotta Timber.'"

THIS invention consists of an improved composition of materials called "Terra cotta Timber," and is intended to be used as a substitute, and sometimes simply as a protection, for wood and metal, while at other times it can be used as a coating for boilers, a material for making grain bins, a lining for fire-proof safes, &c., &c.; indeed the invention does not consist in the use of the composition for certain purposes, but in the preparation or manufacture of the composition no matter for what purpose it may be used. My composition then consists of a combination of kaolinite (or clay without grit) and sawdust mixed with water, so as to make it into a homogeneous mass, and then pressed, dried, and burnt.

Kaolinite is the top clay which commonly overlies fire-brick clay. The sawdust may be of any kind. The proportions of these ingredients may vary with the strength of composition required, but there shall not be more than two parts, nor less than one part, of sawdust to one part of clay.

The clay and sawdust should then be thoroughly ground and mixed in a common clay-grinding mill, sufficient water, say a pailful to 500 or 600 pounds weight, being added to make the whole plastic. From this mill the plastic mixture must be forced through a compressing and forming machine, constructed on the same principles as a cartridge or sausage machine, only that when discharged therefrom it should be in the shape of a thick plank, which can be cut off in any convenient lengths. These lengths are then dried by sun and wind for from four to six days, and afterwards burnt in an ordinary kiln, the heat being increased gradually so as to drive out the moisture, and ultimately to consume the sawdust. When this has been accomplished, the contents of the kiln can be rapidly cooled, and in about thirty hours it is ready for removal and use. "Terra-cotta Timber" so produced can be sawn, planed, tongued, and grooved; bevelled, tenoned, and turned with comparative ease, in fact it can be worked with edged tools into almost any form or shape desired. It is about half the weight of building brick, and tightly retains plastering without lathing. It is a very bad conductor of, and will neither swell nor contract with, either heat or cold. It is a very poor conductor of dampness, sound, or electricity, and is not affected by acids, gases, or age. These peculiar properties enable it to be used for all the purposes I have enumerated at the commencement of this description, and for many others not specifically named.

Having thus described the nature of this invention, and the manner of performing same, I would have it understood that I do not confine myself to the precise proportions of the ingredients used in forming my composition, neither do I confine myself to the use of kaolinite, as any clay free from grit will answer the purpose, but what I claim as a new article of manufacture, for which I am desirous of securing Letters of Registration, is—

My improved composition of materials called "Terra-cotta Timber," consisting of a mixture of kaolinite, or other clay free from grit, and sawdust, both being mixed with water, crushed, pressed into shape, dried, and burnt, substantially as herein described and explained.

In witness whereof, I, the said Charles Carroll Gilman, have hereto set my hand and seal, this twentieth day of October, one thousand eight hundred and eighty-four.

Witness—

W. S. BAYSTON,
Clerk to Edwd. Waters,
Patent Agent, Melbourne.

CHARLES CARROLL GILMAN,
(By his Attorney, J. B. CARTER).

This is the specification referred to in the annexed Letters of Registration granted to Charles Carroll Gilman, this seventeenth day of December, A.D. 1884.

AUGUSTUS LOFTUS.

REPORT.

Sir,

The application of Mr. C. C. Gilman for Letters of Registration for an invention termed "Terra-cotta Timber," having been referred to us, we have examined the specification accompanying the same, and have now the honor to report that we see no objection to the issue of Letters of Registration as prayed for.

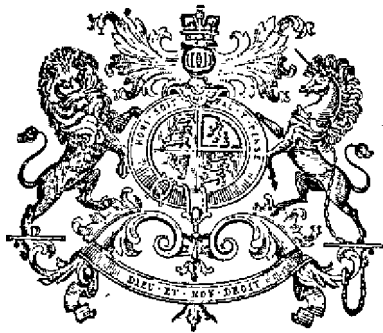
Sydney, 6 November, 1884.

We have, &c.,

J. SMITH.

A. LEIBIUS.

The Under Secretary of Justice.



A.D. 1884, 17th December. No. 1547.

IMPROVEMENT IN THE METHOD OF TANNING, BAITING, SUMACHING, AND
WASHING HIDES, &c.

LETTERS OF REGISTRATION to Messrs. Alderson & Sons, for an Improvement
in the method of Tanning, Baiting, Sumaching, and Washing Hides, Sides, and
Skins of all descriptions by means of a Paddle-wheel and Drum.

[Registered on the 18th day of December, 1884, in pursuance of the Act 16 Vic. No. 24.]

BY HIS EXCELLENCY THE RIGHT HONORABLE SIR AUGUSTUS WILLIAM FREDERICK SPENCER LOFTUS
(commonly called LORD AUGUSTUS LOFTUS), Knight Grand Cross of the Most Honorable Order of
the Bath, a Member of Her Majesty's Most Honorable Privy Council, Governor and Commander-in-
Chief of the Colony of New South Wales and its Dependencies.

TO ALL TO WHOM THESE PRESENTS SHALL COME, greeting :

WHEREAS THOMAS ALDERSON and LAUNCELOT ALDERSON, trading as Alderson & Sons, of
101, York-street, Sydney, in the Colony of New South Wales, leather merchants, have by their Petition
humbly represented to me that they are the authors or designers of a certain invention or improvement
in manufactures, that is to say, of an invention entitled "Improvement in the method of Tanning,
Baiting, Sumaching, and Washing Hides, Sides, and Skins of all descriptions by means of a Paddle-wheel
and Drum," which is more particularly described in the specification and the sheet of drawings which are
hereunto annexed; and that they, the said Petitioners, have deposited with the Honorable the Treasurer of
the said Colony of New South Wales the sum of Twenty Pounds sterling, for defraying the expense of
granting these Letters of Registration, as required by the Act of Council, sixteenth Victoria, number
twenty-four; and have humbly prayed that I would be pleased to grant Letters of Registration, whereby
the exclusive enjoyment and advantage of the said invention or improvement might be secured to them
for a period of fourteen years: And I, being willing to give encouragement to all inventions and improve-
ments in the arts or manufactures which may be for the public good, and having received a report
favourable to the prayer of the said Petition, from competent persons appointed by me to examine
and consider the matters stated therein and to report thereon for my information, am pleased, with the
advice of the Executive Council, and in exercise of the power and authority given to me by the said Act
of Council, to grant, and do by these Letters of Registration grant unto the said Thomas Alderson and
Launcelot Alderson, their executors, administrators, and assigns, the exclusive enjoyment and advantage
of the said invention or improvement for and during the term of fourteen years from the date hereof;
to have, hold, and exercise unto the said Thomas Alderson and Launcelot Alderson, their executors,
administrators, and assigns, the exclusive enjoyment and advantage thereof, for and during and unto
the full end and term of fourteen years from the date of these presents next and immediately ensuing,
and fully to be complete and ended: Provided always, that if the said Thomas Alderson and Launcelot
Alderson shall not, within three days after the granting of these Letters of Registration, register the
same in the proper office in the Supreme Court, at Sydney, in the said Colony of New South Wales, then
these Letters of Registration, and all advantages whatsoever hereby granted, shall cease and become void.

In witness whereof, I have hereunto set my sign manual, and have caused the present Letters of
Registration to be sealed with the seal of the said Colony of New South Wales, at Govern-
ment House, Sydney, in New South Wales, this seventeenth day of December, in the year of
our Lord one thousand eight hundred and eighty-four.

[L.s.]

AUGUSTUS LOFTUS.

Improvement in the method of Tanning, Baiting, Sumaching, and Washing Hides, &c.

SPECIFICATION of MESSRS. ALDERSON & SONS' invention entitled "Improvement in the method of Tanning, Baiting, Sumaching, and Washing Hides, Sides, and Skins of all descriptions by means of a Paddle-wheel and Drum."

THE advantage of our invention is that, by the peculiar construction of a paddle and drum, the goods being treated are kept constantly in motion, and in such a way that there is a tendency to spread each hide and skin out and avoid the knotting or folding together in a ball or lump, thereby allowing every hide and skin to get their proper and equal share of the liquor they may be in.

The drum is constructed exactly as shown, to a curve which has been arrived at after repeated experiment. On it depends the turning of the goods properly as before described.

The accompanying drawing represents in fig. 1 an end elevation of the apparatus; fig. 2 a front elevation; and fig. 3 a section on the line A B.

The ends of the drum are formed of timber tongued and grooved on the horizontal joints, and so cut on the ends that when put together they will give the correct curve on which to construct the "bilge."

The horizontal planks as shown in fig. 2 are set or bevelled on the edge to form a watertight joint and the necessary curve. Grooves at either end are cut, into which the end timbers are fitted. They are strengthened on the outside by wrought-iron bands as shown.

The vessel is open on top for the whole of its length and width. One vertical piece of timber to strengthen the vertical joints, and another to carry the bearing for the shaft, are fixed at either end.

The outside pieces are supported by bolts passing through the ends, and are slotted to admit of the level of the axle being altered.

The paddle-wheel consists of a wooden shaft, octagon in section, having at either end a wrought gudgeon fitted into it and secured by a pin as shown, the rest of the gudgeon to consist of a wrought-iron collar and an overlength of turned shaft to fit the bearings and carry the driving pulleys. The timber shaft is hooped at either end with iron. The bearings are of gun metal fitted into the vertical timbers, and secured by screws through the flange, and are bored to take the shaft.

Two pulleys are provided, one keyed on shaft, and the other running loose.

Into the octagon shaft are mortised and fitted eight wooden arms, each of them tapered on three sides, their horizontal relative position being as follows:—

The first is a distance C from the inner side of the end of the vessel. The second, third, fourth, and fifth are each successively a distance equal to D nearer to the centre of the vessel, each being on a separate face of the shaft. The sixth, seventh, and eighth are on faces exactly opposite, and the same distance from the centre as the second, the third, and the fourth respectively.

The paddles are eight flat boards which, being attached to the extremities of the arms, form a complete paddle-wheel.

A suitable timber wood to prevent the splashing of the liquor completes the arrangement.

Having thus described our invention and the peculiarity of the action of the apparatus, we do not confine ourselves to the precise details herein laid down or shown in the drawing herewith as to sizes, as the same may be modified without departing from the character of our invention.

This construction being an improvement on all other drums, we claim it as our invention, and are desirous of obtaining Letters of Registration for the same.

THOMAS ALDERSON.
L. ALDERSON.

This is the specification referred to in the annexed Letters of Registration, granted to Thomas Alderson and Launcelot Alderson, the seventeenth day of December, A.D. 1884.

AUGUSTUS LOFTUS.

REPORT.

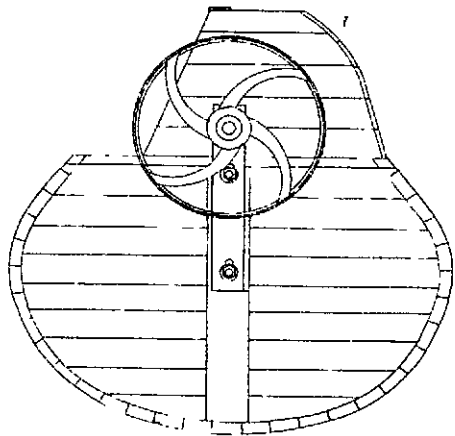
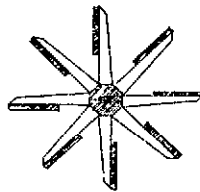
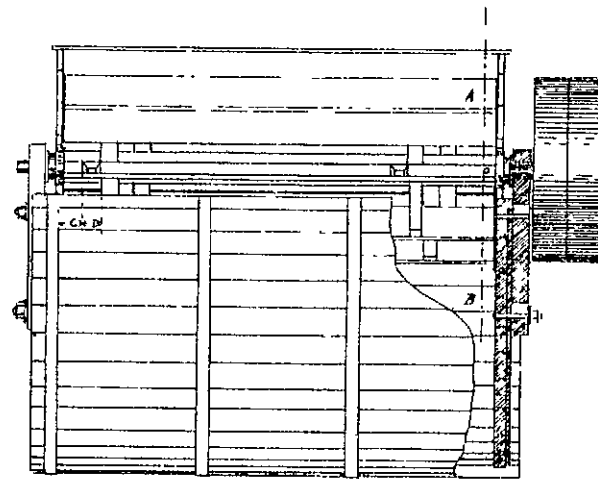
Sir,

Sydney, 6 November, 1884.

In the matter of the application of Messrs. Alderson and Sons, for Letters of Registration for an "Improvement in the method of Tanning, &c.," which has been referred to us, we have examined the specification and drawings accompanying the same, and have the honor to report that we see no objection to the issue of Letters of Registration as prayed for.

The Under Secretary of Justice.

We have, &c.,
J. SMITH.
A. LEIBIUS.

FIG 1FIG 3FIG 2

*This is the Sheet of Drawings referred to in the annexed
Letters of Registration granted to Thomas Aiterson, and
Launcelet Aiterson on the seventeenth day of December, A.D. 1884.
Augustus Loftus.*

(Sig. 245-)



A.D. 1884, 22nd December. No. 1548.

AN IMPROVEMENT IN PACKAGES FOR TEA AND OTHER PURPOSES.

LETTERS OF REGISTRATION to William Harper, Robert Harper, and John Harper, for an Improvement in Packages for Tea and other purposes.

[Registered on the 23rd day of December, 1884, in pursuance of the Act 16 Vic. No. 24.]

BY HIS EXCELLENCY THE RIGHT HONORABLE SIR AUGUSTUS WILLIAM FREDERICK SPENCER LOFTUS (commonly called LORD AUGUSTUS LOFTUS), Knight Grand Cross of the Most Honorable Order of the Bath, a Member of Her Majesty's Most Honorable Privy Council, Governor and Commander-in-Chief of the Colony of New South Wales and its Dependencies.

TO ALL TO WHOM THESE PRESENTS SHALL COME, greeting :

WHEREAS WILLIAM HARPER and ROBERT HARPER, both of No. 12, Flinders Lane East, in the City of Melbourne and Colony of Victoria, merchants, and JOHN HARPER, of Sydney, in the Colony of New South Wales, merchant, have by their Petition humbly represented to me that the Petitioner, the said William Harper, is the author or designer of a certain invention or improvement in manufactures, that is to say, of an invention entitled "An Improvement in Packages for Tea and other purposes," which is more particularly described in the specification, with drawings therein, which is herunto annexed; and that the Petitioners, the said Robert Harper and John Harper, are the assignees of the said William Harper of and in the said invention jointly with the said William Harper, so far as the said Colony of New South Wales is concerned; and that they, the said Petitioners, have deposited with the Honorable the Treasurer of the said Colony of New South Wales the sum of Twenty Pounds sterling, for defraying the expense of granting these Letters of Registration, as required by the Act of Council, sixteenth Victoria, number twenty-four; and have humbly prayed that I would be pleased to grant Letters of Registration, whereby the exclusive enjoyment and advantage of the said invention or improvement might be secured to them for a period of fourteen years: And I, being willing to give encouragement to all inventions and improvements in the arts or manufactures which may be for the public good, and having received a report favourable to the prayer of the said Petition from competent persons appointed by me to examine and consider the matters stated therein and to report thereon for my information, am pleased, with the advice of the Executive Council, and in exercise of the power and authority given to me by the said Act of Council, to grant, and do by these Letters of Registration grant unto the said William Harper, Robert Harper, and John Harper, their executors, administrators, and assigns, the exclusive enjoyment and advantage of the said invention or improvement, for and during the term of fourteen years from the date hereof; to have, hold, and exercise unto the said William Harper, Robert Harper, and John Harper, their executors, administrators, and assigns, the exclusive enjoyment and advantage thereof, for and during and unto the full end and term of fourteen years from the date of these presents next and immediately ensuing, and fully to be complete and ended: Provided always, that if the said William Harper, Robert Harper, and John Harper shall not, within three days after the granting of these Letters of Registration, register the same in the proper office in the Supreme Court, at Sydney, in the said Colony of New South Wales, then these Letters of Registration, and all advantages whatsoever hereby granted, shall cease and become void.

In witness whereof, I have herunto set my sign manual, and have caused the present Letters of Registration to be sealed with the seal of the said Colony of New South Wales, at Government House, Sydney, in New South Wales, this 22nd day of December, in the year of our Lord one thousand eight hundred and eighty-four.

[L.S.]

AUGUSTUS LOFTUS.

An Improvement in Packages for Tea and other purposes.

SPECIFICATION of WILLIAM HARPER and ROBERT HARPER, both of No. 12, Flinders Lane East, in the City of Melbourne and Colony of Victoria, merchants, and JOHN HARPER, of Sydney, in the Colony of New South Wales, merchant, the assignees of the said William Harper, for an invention entitled "An Improvement in Packages for Tea and other purposes."

THIS invention has been designed for the purpose of providing the metallic cans, canisters, or packages used for holding tea, coffee, spices, confectionery, or any other description of grocers' or other merchandise, with a hinged cover, which is affixed over an aperture in one corner of the top of the package; this cover has a wing formed at its one side equal in size and similar in shape to it, so that when the cover is opened out to its full extent it serves the purpose of a shoot in emptying the can or package. Our improvement may also be applied to packages or boxes made from papier-mache card-board, or other such-like material, used for holding merchandise similar to that above stated.

In order that our invention may be better understood, we will now describe it with reference to the sketches in the margin hereof, where figure 1 shows the cover closed, and figure 2 shows it open; figure 3 shows it partially open, and attached to a package of a different shape; while figure 4 represents our improvement by itself. In these figures A is the cover, hinged at A' to the top of the box, so as to cover, when closed, the opening B therein. C is the wing formed on and standing at right angles to the plane of the cover, and this wing passes down into the package or case, and its outermost edge works in a slit or guide, C', formed in the top of the case, and at its lower extremity inside of the case I form a stud or projection, C², which prevents it from passing through said guide C', and also holds it in its proper position when acting as a shoot.

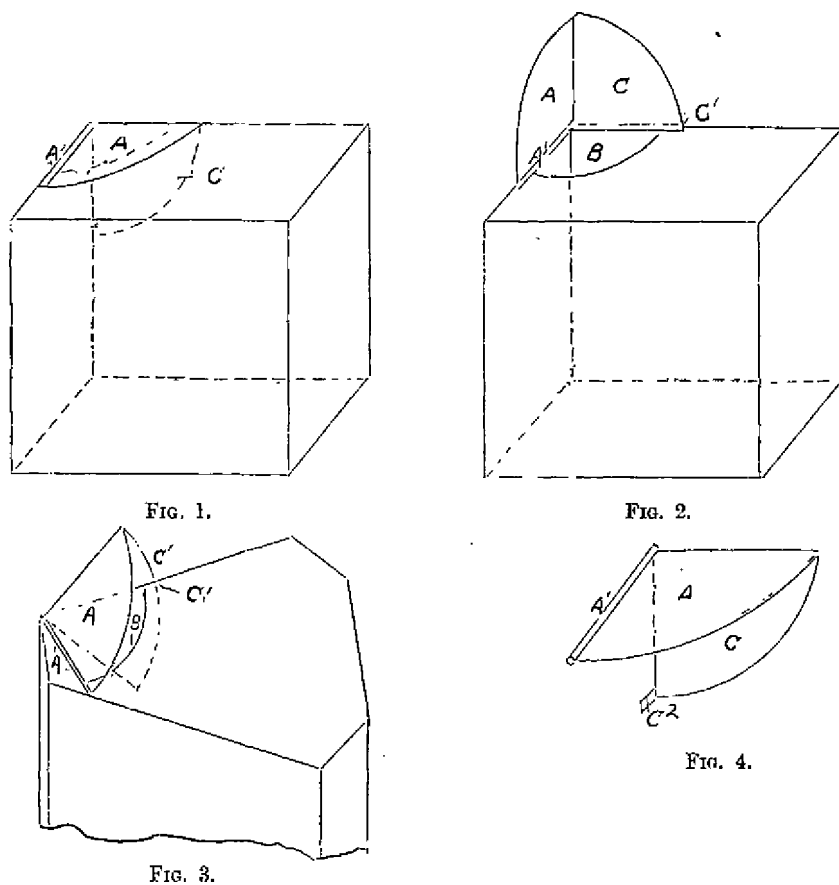


FIG. 1.

FIG. 2.

FIG. 3.

FIG. 4.

Having thus described the nature and object of our invention, what we believe to be new, and therefore claim as our improvement in packages for tea and other purposes, is—

The hinged cover A having a wing B formed on it, which descends into the case or package when the door is closed, and opens out with the cover as it is opened so as to form a shoot for convenience in emptying the case or package of its contents, substantially as and for the purposes herein described and explained, and as illustrated by the sketches in the margin hereof.

In witness whereof we, the said William Harper, Robert Harper, and John Harper, have hereto set our hands and seals this third day of November, one thousand eight hundred and eighty-four.

W. HARPER.
ROBERT HARPER.

Witness to the signature of William Harper and Robert Harper,—
P. J. BROWNELL, 3, Anderson-street, S.M.

Witness to the signature of John Harper,
P. J. BROWNELL, 3, Anderson-street, S.M.

EDWARD WATERS, Agent.

JOHN HARPER,
(By his Agent, W. HARPER).

This is the specification, with drawings therein, referred to in annexed Letters of Registration, granted to William Harper, Robert Harper, and John Harper, the twenty-second day of December, A.D. 1884.

AUGUSTUS LOFTUS.

REPORT.

An improvement in Packages for Tea and other purposes.

REPORT.

Sir,

We do ourselves the honor to return the papers referred to us by your B.C. communication, dated the 5th instant, containing an application from Messrs. W. Harper, R. Harper, and J. Harper, for Letters of Registration for an invention entitled, "An improvement in Packages for Tea and other purposes." Having examined the specification and drawings, we beg to report that we see no objection to the issue of the Letters of Registration applied for.

Sydney, 8 November, 1884.

We have, &c.,

EDMUND FOSBERY.
E. C. CRACKNELL.The Under Secretary of Justice.



A.D. 1884, 22nd December. No. 1549.

RELIEF BLOCKS FOR PRINTING BY A PHOTOGRAPHIC ENGRAVING PROCESS.

LETTERS OF REGISTRATION to Camfield Baker, for an Invention for making Relief Blocks for Printing by a Photographic Engraving Process.

[Registered on the 23rd day of December, 1884, in pursuance of the Act 16 Vic. No. 24.]

By HIS EXCELLENCY THE RIGHT HONORABLE SIR AUGUSTUS WILLIAM FREDERICK SPENCER LOFTUS (commonly called LORD AUGUSTUS LOFTUS), Knight Grand Cross of the Most Honorable Order of the Bath, a Member of Her Majesty's Most Honorable Privy Council, Governor and Commander-in-Chief of the Colony of New South Wales and its Dependencies.

TO ALL TO WHOM THESE PRESENTS SHALL COME, greeting :

WHEREAS CAMFIELD BAKER, of 87, Clarence street, Sydney, hath by his Petition humbly represented to me that he is the author or designer of a certain invention or improvement in manufactures, that is to say, of an invention "For making Relief Blocks for Printing by a Photographic Engraving Process," which is more particularly described in the specification which is hereunto annexed; and that he, the said Petitioner, hath deposited with the Honorable the Treasurer of the said Colony of New South Wales the sum of Twenty Pounds sterling, for defraying the expense of granting these Letters of Registration, as required by the Act of Council, sixteenth Victoria, number twenty-four; and hath humbly prayed that I would be pleased to grant Letters of Registration, whereby the exclusive enjoyment and advantage of the said invention or improvement might be secured to him for a period of fourteen years: And I, being willing to give encouragement to all inventions and improvements in the arts or manufactures which may be for the public good, and having received a report favourable to the prayer of the said Petition, from competent persons appointed by me to examine and consider the matters stated therein and to report thereon for my information, am pleased, with the advice of the Executive Council, and in exercise of the power and authority given to me by the said Act of Council, to grant, and do by these Letters of Registration grant unto the said Camfield Baker, his executors, administrators, and assigns, the exclusive enjoyment and advantage of the said invention or improvement, for and during the term of fourteen years from the date hereof; to have, hold, and exercise unto the said Camfield Baker, his executors, administrators, and assigns, the exclusive enjoyment and advantage thereof, for and during and unto the full end and term of fourteen years from the date of these presents next and immediately ensuing, and fully to be complete and ended: Provided always, that if the said Camfield Baker shall not, within three days after the granting of these Letters of Registration, register the same in the proper office in the Supreme Court, at Sydney, in the said Colony of New South Wales, then these Letters of Registration, and all advantages whatsoever hereby granted, shall cease and become void.

In witness whereof, I have hereunto set my sign manual, and have caused the present Letters of Registration to be sealed with the seal of the said Colony of New South Wales, at Government House, Sydney, in New South Wales, this twenty-second day of December, in the year of our Lord one thousand eight hundred and eighty-four.

AUGUSTUS LOFTUS.

Invention for making Relief Blocks for Printing by a Photographic Engraving Process.

SPECIFICATION of patent for making Relief Blocks for Printing by a Photographic Engraving Process.

I, CAMFIELD BAKER, do hereby declare the nature of the said invention for making relief blocks, as electrotypes, stereotypes, or otherwise, for printing purposes, to be as follows :—

1st—I first coat or cover a sheet of glass, in a darkened room, the required size of block or otherwise, with a thin stratum of bitumen, mineral pitch, asphaltum, or jew's pitch. When dry, expose the same under photographic or other negative, as in paper photographic processes, the sensitized bitumen glass plate taking the place of the sensitized paper, sufficiently long to the influence of the solar electric or other actinic light, from ten to thirty minutes or more, according to strength of same light; when sufficiently exposed, clean off the bitumen, mineral pitch, asphaltum, or jew's pitch, unaffected by the actinic light, with turpentine, benzine, or any other suitable solvent.

2nd—I now "ink up" the glass plate in same manner as lithographing on zinc, till sufficient body of ink is deposited on the bitumen acted on by the actinic light, the glass face, where the unaltered bitumen was cleared away by solvent, remaining perfectly bright and clear.

3rd—I now powder over the surface finely pulverized resin, seedlac, sticklac, shellac, damar, copal, or sandarac; after well dusting in I carefully brush off all superfluous resin, seedlac, sticklac, shellac, damar, copal, or sandarac, and raise the temperature of plate to 250 degrees Fah. or thereabout.

4th—When sufficiently cool treat the plate with fluoric acid, which dissolves away the face of the glass unprotected by the bitumen and resin; when sufficient depth is obtained, well wash, dry, and thoroughly clean with turpentine, benzine, or other suitable material, after which the block can be mounted for printing, or electrotyped or stereotyped from in the usual manner.

Having described the process of my invention, I hereunder claim as new, original, and of my own invention—

1st—I claim as new and original the applying the photographic process as a means for producing on the glass any design suitable for printing from, in a pigment sufficient to resist the action of fluoric acid, in lieu of the more laborious method of drafting direct on the glass by hand.

2nd— I claim by this process to be able to complete a block for printing in less time than it can be done by any other practical process, as a block can easily be produced ready for the press in three hours, which will be a great boon to the press and the public generally.

CAMFIELD BAKER.

This is the specification referred to in the annexed Letters of Registration granted to Camfield Baker, the twenty-second day of December, A.D. 1884.

AUGUSTUS LOFTUS.

REPORT.

Sir,

Sydney, 12 November, 1884.

The application of Mr. Camfield Baker for Letters of Registration for an invention entitled "Making Relief Blocks for Printing by a Photographic Engraving Process," having been referred to us, we have examined the plan and specification accompanying the same, and have now the honor to report that we see no objection to the issue of Letters of Registration as applied for.

We have, &c.,
 ARCH. C. FRASER.
 THOS. RICHARDS.

The Under Secretary of Justice.



A.D. 1884, 22nd December. No. 1550.

IMPROVEMENTS IN STREET RAILWAYS.

LETTERS OF REGISTRATION to Henry Hudson and Norman Selfe for
Improvements in Street Railways.

[Registered on the 23rd day of December, 1884, in pursuance of the Act 16 Vic. No. 24.]

BY HIS EXCELLENCY THE RIGHT HONORABLE SIR AUGUSTUS WILLIAM FREDERICK SPENCER LOFTUS (commonly called LORD AUGUSTUS LOFTUS), Knight Grand Cross of the Most Honorable Order of the Bath, a Member of Her Majesty's Most Honorable Privy Council, Governor and Commander-in-Chief of the Colony of New South Wales and its Dependencies.

TO ALL TO WHOM THESE PRESENTS SHALL COME, greeting :

WHEREAS HENRY HUDSON and NORMAN SELFE, both of Sydney, in the Colony of New South Wales, have by their Petition humbly represented to me that they are the assignees of George Pardy, of San Francisco, California, one of the United States of America, who is the author or designer of a certain invention or improvement in manufactures, that is to say, of an invention entitled "Improvements in Street Railways," which is more particularly described in the specification and the sheet of drawings which are hereunto annexed; and that they, the said Petitioners, have deposited with the Honorable the Treasurer of the said Colony of New South Wales the sum of Twenty Pounds sterling, for defraying the expense of granting these Letters of Registration, as required by the Act of Council, sixteenth Victoria, number twenty-four; and have humbly prayed that I would be pleased to grant Letters of Registration, whereby the exclusive enjoyment and advantage of the said invention or improvement might be secured to them for a period of fourteen years: And I, being willing to give encouragement to all inventions and improvements in the arts or manufactures which may be for the public good, and having received a report favourable to the prayer of the said Petition from competent persons appointed by me to examine and consider the matters stated therein and to report thereon for my information, am pleased, with the advice of the Executive Council, and in exercise of the power and authority given to me by the said Act of Council, to grant, and do by these Letters of Registration grant unto the said Henry Hudson and Norman Selfe, their executors, administrators, and assigns, the exclusive enjoyment and advantage of the said invention or improvement, for and during the term of fourteen years from the date hereof; to have, hold, and exercise unto the said Henry Hudson and Norman Selfe, their executors, administrators, and assigns, the exclusive enjoyment and advantage thereof, for and during and unto the full end and term of fourteen years from the date of these presents next and immediately ensuing, and fully to be complete and ended: Provided always, that if the said Henry Hudson and Norman Selfe shall not, within three days after the granting of these Letters of Registration, register the same in the proper office in the Supreme Court, at Sydney, in the said Colony of New South Wales, then these Letters of Registration, and all advantages whatsoever hereby granted, shall cease and become void.

In witness whereof, I have hereunto set my sign manual, and have caused the present Letters of Registration to be sealed with the seal of the said Colony of New South Wales, at Government House, Sydney, in New South Wales, this twenty-second day of December, in the year of our Lord one thousand eight hundred and eighty-four.

[L.S.]

AUGUSTUS LOFTUS.

Improvements in Street Railways.

SPECIFICATION of HENRY HUDSON and NORMAN SELLE, both of Sydney, in the Colony of New South Wales, the assignees of George Pardy, of San Francisco, California, one of the United States of America, who is the author or designer of an invention for "Improvements in Street Railways."

My invention relates to a new and useful system of operating street railroads with compressed air, and has for its object:—

First—To provide a practical method by which the air may be used at lower pressure than heretofore, so as to acquire all the advantages of economy, safety, convenience, the non-formation of ice in exhausting, and increased efficiency generally.

Second—To provide for the reduction of the weight and bulkiness of the motor, so as to make practical the application of compressed air as a motive power to operate roads having light traffic but frequent trips, and which could not be run with profit with such heavy and cumbersome machinery as is required when the motors are charged to run long distances.

My invention consists mainly in the application of a storage and charging pipe which carries the air below the surface of the road-bed all along the route contiguous to the track, and which, through a system of valves attached to this pipe closely set together within the track, is made practically (and absolutely if needed) available for tapping to take a supply therefrom to replenish the receivers upon the car at any and all points in the route, or, in other words, the system is so arranged that the car is never removed from its source of supply, and has no determined distance to travel with each charge, and may, therefore, be constructed so as to have the minimum capacity both as to storage room and pressure of the air, instead of the maximum, as when the length of the journey to the charge is absolute and fixed.

Compressed-air motors have been run a definite distance without replenishing, as from end to end of the route and back; and suggestions have been made to run from station to station, using a pipe connection between, but in all cases provisions had to be made for carrying the heaviest possible load of passengers under the most adverse circumstances likely to occur, such as those arising from very frequent stoppages, bad condition of the track, accidental delays, &c. The definite points could not be passed without refilling the receivers, and either the engineer had to go, or the motor itself had to be taken to the station off from the main line in the act of refilling, this system of operation leading to all the difficulties which has heretofore surrounded the use of compressed air as a motive power for street roads.

No practical system has ever been devised, so far as I am aware, by which the motor could be resupplied with air at any and all points in the route.

In the present invention the maximum weight of the load and the contingencies of the trip do not control, but have only the effect of limiting the distance the motor will be capable of travelling without having recourse to the supply pipe constantly at hand; no definite stopping places are ordinarily necessary, in fact, those stoppages only which are of necessity caused by taking on and letting off passengers are the only ones which I propose to make, it being calculated that these will be ample in most cases to give the required opportunity to replenish the receivers.

Of course where under this system the great reductions of the weight of the motor brings us into the difficulty of not having sufficient adhesion to the track to give the machine, when the carrying wheels are used as drivers, sufficient power to go up grades, or to haul other cars behind it, some provision must be made to overcome the difficulty, otherwise much of the usefulness of the plan would be destroyed; therefore, whenever the conditions demand it, I shall provide a central slotted track between the rails, on top of which I will run driving wheels, and below this track in a channel way other wheels to be drawn up tightly by levers in such manner as that the track itself will be gripped with more or less force between the faces of the upper and lower wheels, thus acquiring all the adhesion that may be necessary.

In the accompanying drawing, forming part of my specification, fig. 1 is a side elevation of my motor, with the rear wheels removed so as to show the engine cylinders, and including a sectional view of the channel way and supply pipe below the track. Fig. 2 is a cross-section of the channel way, driving wheels, and a part of the motor, so as to show its relation to the other parts. Fig. 3 is an enlarged sectional view of the valvular outlet from the main pipe, and the valvular end of the refilling nozzle, both coupled together, as in the act of refilling. Fig. 4 is an enlarged side view of the driving and gripping wheels. Fig. 5 is a sectional elevation of the same.

In all the figures like letters of reference represent like parts.

A, fig. 1, is a motor constructed as an open car, after the style of the cable-road dummies. The air receivers B are placed under the seats C, and are indicated by circles in fig. 2, and dotted lines, fig. 1.

From these receivers, which are connected together by a pipe D, a hose connection E is made, which terminates in a metal nozzle F, in the end of which is fitted a valve G, opening inwardly; and closed by a spring and the pressure in the receivers B. (See fig. 3.)

H is a pipe, preferably laid underground near the track, large enough to have in itself storage capacity sufficient to insure that the drawing off of each charge for the motors will not greatly decrease the pressure; 5 to 6 inches diameter for roads running cars five minutes apart, whilst it should never be less than 4 inches diameter; the larger the pipe within the limits the better. This pipe is provided with right-angle branches, say every 300 feet, more or less, which lead to the centre of the track, and terminate in valvular outlets, I, having an inwardly opening valve similar to the one on the end of the nozzle, also held closed by the pressure behind it and a spring. When the nozzle is coupled to the outlet of the pipe, the stems of the two valves meet, and are pressed apart by the operator, and the air passes through from the main into the receivers on the motor. In the act of uncoupling the nozzle the two valves spring together again, and both the nozzle and outlet from the main are tightly closed.

The nozzle is subject to an upward pressure, tending to blow it out of the chamber I, as soon as the valve of the main opens, and to prevent this the nozzle must be locked down when filling. I show a projection L in dotted lines in fig. 3, attached to the nozzle. This inserts under a lip M on the outlet of the main, which lip is slightly inclined, so that by giving the nozzle a slight turn, just before the end of the nozzle becomes seated, the valves will be spread apart by the action.

There is nothing, however, absolutely material and indispensable in the construction of the nozzle or underground valve. In the operation of this system various devices may be used; all that is necessary is that the connection with the main shall be quickly made in a convenient manner. In

Improvements in Street Railways.

In figures 3^A, 3^B, and 3^C, are shown in sectional elevation, alternative arrangements of the underground valve and connection to the motor reservoir. In fig. 3^A, upon the insertion of the nozzle F the pin F¹ forces back lever F² against the stem of the valve G¹, and opens it, and the air under pressure passing through and opening the valve G passes through into the reservoir B, and on the withdrawal of said nozzle the pressure closes both valves. The pin F¹ is inserted in place through a screw plug not shown. If preferred the lever F² may be dispensed with by using dropping-down valves, and operating direct on the stem. In fig. 3^B on a partial revolution of the nozzle F when inserted, the lips L catch under lugs M, and the stem opens valves G and G¹, leaving a free passage on the withdrawal of said nozzle, the pressure again closes the valves. In fig. 3^C the nozzle F forms the plug of an intermediate plug G in the cock G¹, and upon the insertion of the nozzle the openings in both said plugs are coincident by reason of projection L fitting into recess M, and upon a partial revolution projection L in recess M insures the revolution of plug G, and thus opens the cock and makes a free passage through to the reservoir; the cock is closed by a partial revolution in the opposite direction, when the nozzle F may be withdrawn. Fig. 6 shows a section of roadway with one of these latter connections in position.

Where these valvular outlets occur in the main I propose, if found necessary or desirable, to place reservoirs K so that a great volume of air may be immediately at hand to draw from, and a quicker operation in replenishing the receivers will be effected.

When the route is a long one, and it is desirable to avoid stopping the entire line, when the service pipe gets out of order, there may be compressing engines at both ends of the line, so that a leaking portion of the pipe may be cut out by stop valves until the repairs are done. With this arrangement two pressures may be used, as, for instance, if the grades are heavy at one end of the route the pressure may be, say, 100 lb. per square inch, whilst at the other end, if the grades be lighter, it may be sufficient to carry 60 lb. pressure. A stop valve will intervene between the two pressures. Stop valves should be placed at frequent intervals on the pipe to give facilities for locating leakages.

N N are the air-engine cylinders. They connect in ordinary manner with the driving wheels O O (when these are used, otherwise they will connect directly with the carrying wheels or their axles). The wheels O O are supported on a strong axle P, which is borne in boxes Q, supported on the hanger R, which in turn is carried on the axles of the carrying wheels. Under these driving wheels are the grip wheels S, which run in a channel-way T, made of channel irons set edge to edge with a space between at top. (See figures 2 and 5). On the axle of the grip wheels and between them is a lever U, which is forked at its upper end, and straddles the axle of the drivers, so as to connect above to the hand lever V. This hand lever has its fulcrum on the axle of the driving wheels as shown, and its forward and backward movement effects through the lever U a gripping of or releasing of the wheels S from the channel irons. The ordinary notched quadrant and pawl, shown at W, is used to hold the lever V when set. In front of the drivers may be a wire brush X to keep the track clean, for obstructions of any size would cause damage. It may be necessary to provide for some spring in the drivers when obstructions occur, as, for instance, let the drivers have a rubber ring between periphery and hub. This construction is not shown, for it is not thought to be necessary. If proper attention is paid to obtaining even thickness of channel iron all along the route no difficulty will occur.

The system of operating is as follows:—The storage and supply pipe being filled with air, say at a pressure of 100 lb. per square inch, the motor's receivers are filled therefrom at the depot at full pressure on starting out; as it proceeds on its trip the air is used in the engines either at full pressure direct from the receivers, or may be reduced to say 30 lb. by passing it through the commonly known reducing valves. When the conductor strikes the bell to stop for a passenger to get on or off the car, the engineer stops at just where the next valve of the supply pipe is located, or at least within a few feet thereof. He then takes down his feeding nozzle and inserts it into the hole in the street, and connects, previously removing its cover. (The cover may be made to move automatically if preferred.) The air rushes through the pipe to fill the receivers until the bell sounds again to start, when the nozzle is taken up and replaced on its stand. The engineer need not wait to get the final few pounds of pressure, but may start again with such pressure as he has obtained; in this way no unnecessary delay occurs.

The car or motor need not be required to travel over six or eight blocks, or even a less distance, where stops are frequent. Usually the ordinances of cities and towns require the cars to stop only at crossings; in such cases the valves need only be placed there, though they may be placed every 100 feet, more or less, if the cars are permitted to stop between crossings, for it is desirable to be able to refill the receivers during every stop, so as to have great pressure when starting.

Several suggestions have been made to operate streets railroads with compressed air carried in a pipe near the track. Some of these have been totally impracticable, and none have included within their scope the system herein proposed.

What I claim as my invention is—

First—In pneumatic railroads, the combination with a storage and supply pipe conveying the compressed air along the road, contiguous to the track, of underground valves connected with said pipe, and placed as to be accessible to refill the receivers on the motor at any and all desired points on the route, substantially as and for the purpose herein described.

Second—In pneumatic railroads, the combination with a storage and supply pipe passing along the route contiguous to the track of a series of valvular outlets, placed at such frequent intervals and accessible for refilling the receivers by the engineer from his stand upon the motor, that he may utilize the time the motor is stayed for passengers (but without additional delay), in re-supplying said receivers, substantially as and for the purposes described.

Third—In pneumatic street railroads, the combination of a storage and supply pipe, conveying compressed air along the route contiguous to the track, a series of underground valvular outlets attached thereto, and a flexible pipe connection with the receivers on the motor, arranged so as to be coupled with the valvular outlets, substantially as and for the purpose described.

Fourth—

Improvements in Street Railways.

Fourth—In pneumatic street railroads, the combination of a storage and supply pipe, conveying compressed air along the route, a series of valvular outlets therefrom, and suitable mechanism, substantially as described, to connect said outlets with the receivers on the motor without obstructing the street, as and for the purpose described.

Fifth—The method herein described of operating with compressed air as a motive power for street railroads, by which the motors may be reduced in size and storage capacity, and the air may be used at lower initial pressure than heretofore, consisting of re-supplying said motors from a storage and supply pipe, having valvular outlets at indefinite intervals, determined by the stoppages made for passengers, and the actual requirements of each trip, substantially as and for the purpose set forth.

Sixth—In pneumatic railroads, the combination with a supply and storage pipe, having valvular outlets at intervals, to supply the receivers on the motor, of enlarged receptacles for the air, at near these outlets, and from which the supply for the receivers may be the more quickly drawn, substantially as set forth.

Seventh—In railway motors, the combination of the driving wheels O, suitably connected with and rotated by an engine, under grip wheels S, track T, and suitable mechanism to raise and lower the wheels S, arranged and operating substantially as described, and for the purpose set forth.

Eighth—In railway motors, the combination of the driving wheels O, suitably connected with and rotated by an engine, under grip wheels S, track T, and levers U and V, arranged and operating substantially as and for the purpose described.

Ninth—In pneumatic railways, in combination with a supply and storage pipe, as described, and a motor having storage tanks, the flexible connection between the two, consisting of the rubber hose and metal nozzle with check valve therein, as and for the purpose described.

In witness whereof, we, the said Henry Hudson and Norman Selfe, have hereto set our hands and seals, this twenty-first day of July, one thousand eight hundred and eighty-four.

Witness—

FRED. WALSH,
Manager, E. Waters' Patent Office, Sydney.

HENRY HUDSON.
NORMAN SELFE.
(By his Agent, HENRY HUDSON.)

This is the specification referred to in the annexed Letters of Registration granted to Henry Hudson and Norman Selfe, the twenty-second day of December, A.D. 1884.

AUGUSTUS LOFTUS.

REPORT.

Sir,

Referring to your B.C. memo. of the 22nd ultimo, forwarding a petition from Messrs. Hudson and Selfe for Letters of Registration for an invention entitled "Improvements in Street Railways," we have the honor to state that, having examined the plan and specification accompanying the same, we are of opinion that the prayer of the petitioner for the issue of Letters of Registration for the invention in question may be granted.

We have, &c.,

The Under Secretary of Justice.

JOHN WHITTON.
E. O. MORIARTY.

[Drawings—one sheet.]

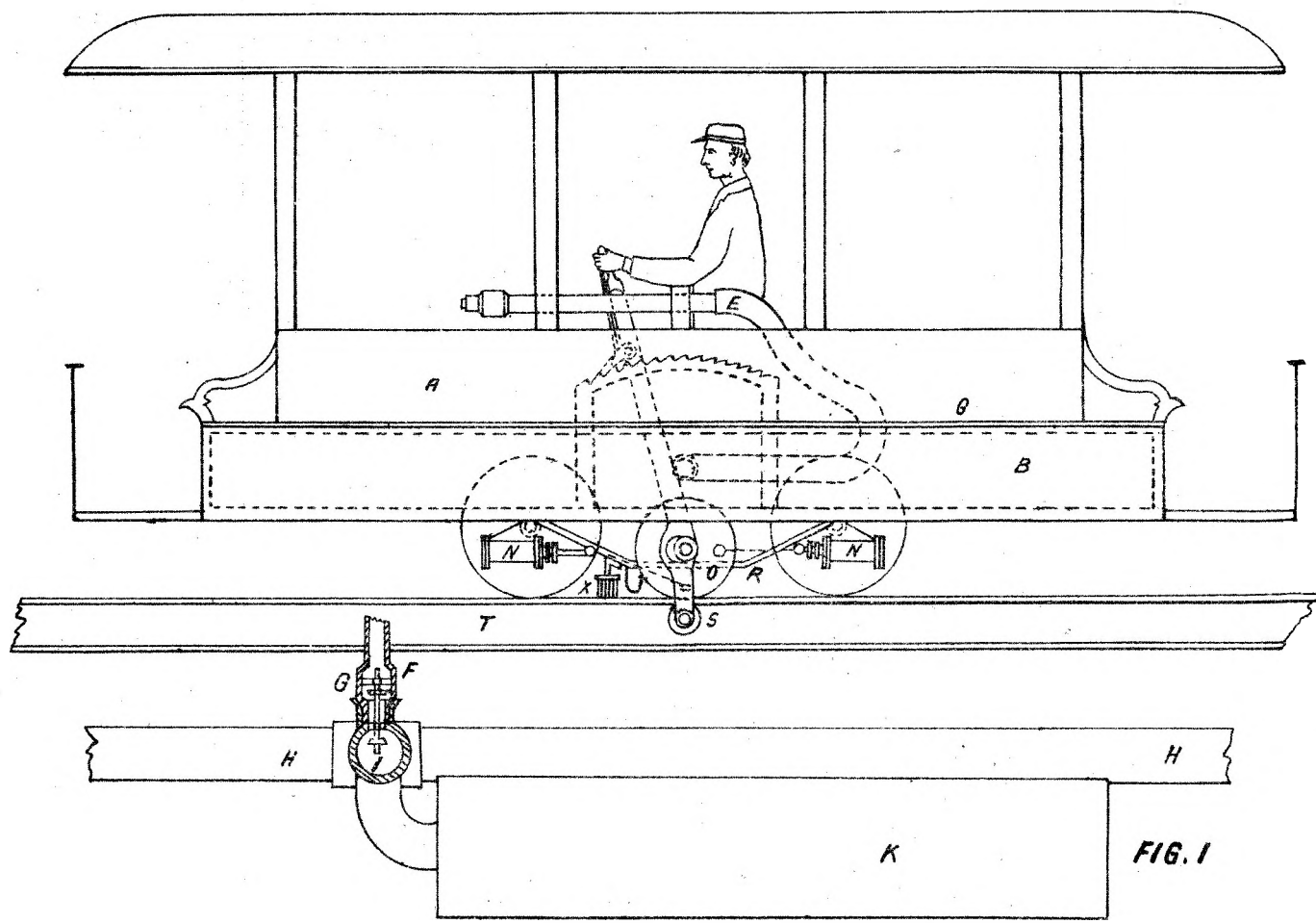


FIG. 1

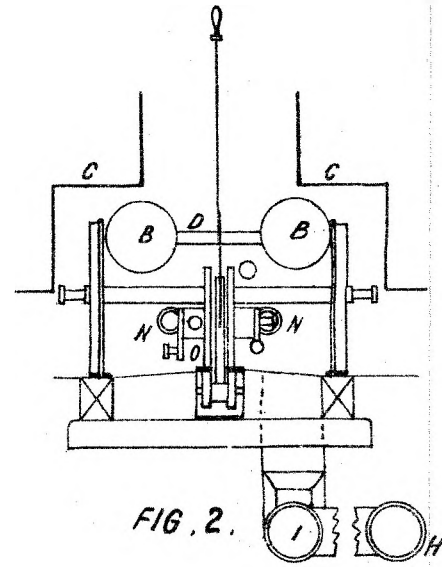


FIG. 2.

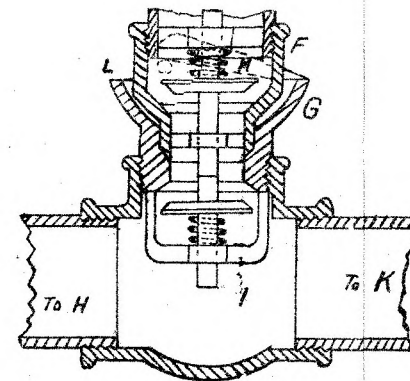


FIG. 3.

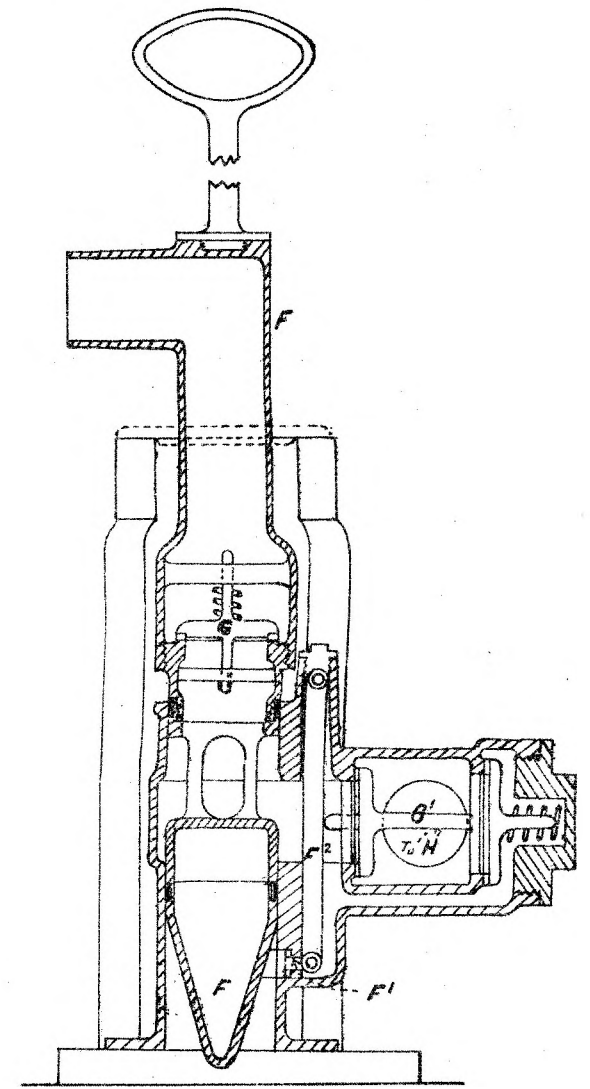


FIG. 3^A

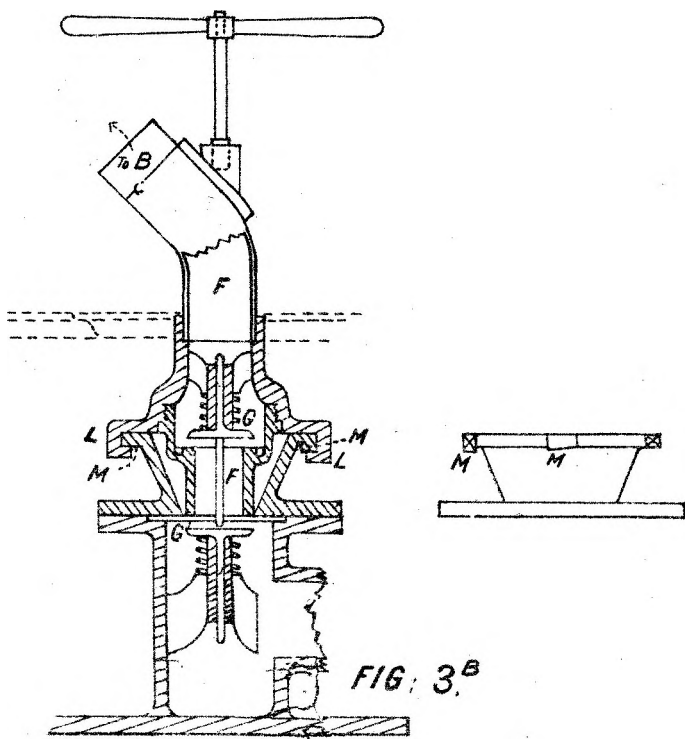


FIG. 3^B

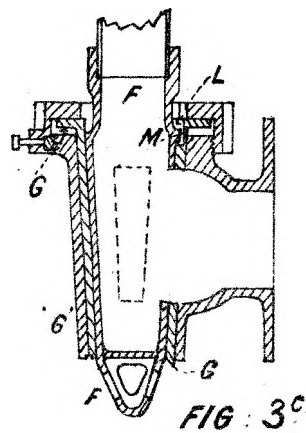


FIG. 3^C

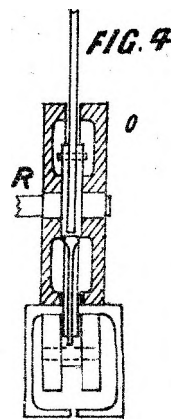


FIG. 4

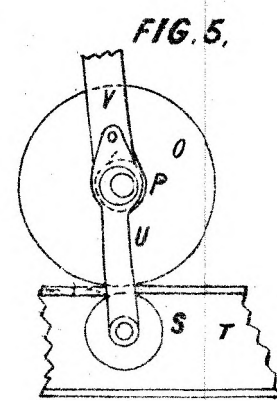


FIG. 5.

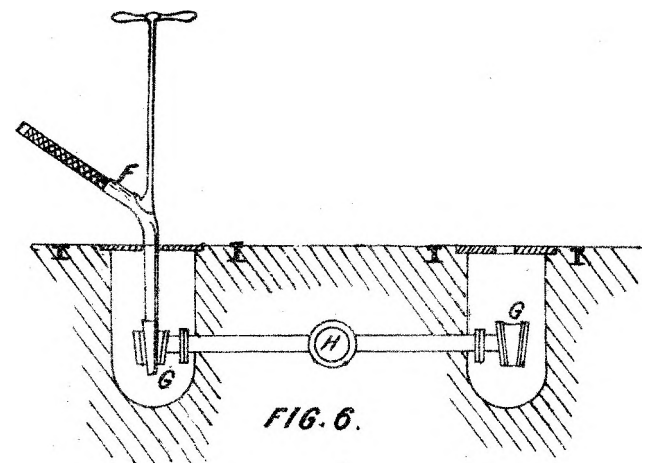


FIG. 6.

(Sig. 245~)

*This is the Sheet of Drawings referred to in the annexed
 Letters of Registration, granted to Henry Hudson, and Norman
 Sells, the twenty second day of December. A. D., 1884.
 Augustus Loftus.*

PHOTO-LITHOGRAPHED AT THE GOVT. PRINTING OFFICE,
 SYDNEY, NEW SOUTH WALES.



A.D. 1884, 30th December. No. 1551.

IMPROVEMENTS IN THE GLAZING OF ROOFS AND OTHER STRUCTURES.

LETTERS OF REGISTRATION to Joseph Duke Mackenzie and William Atchison, for Improvements in, and relating to, the Glazing of Roofs and other structures.

[Registered on the 30th day of December, 1884, in pursuance of the Act 16 Vic. No. 24.]

BY HIS EXCELLENCY THE RIGHT HONORABLE SIR AUGUSTUS WILLIAM FREDERICK SPENCER LOFTUS (commonly called LORD AUGUSTUS LOFTUS), Knight Grand Cross of the Most Honorable Order of the Bath, a Member of Her Majesty's Most Honorable Privy Council, Governor and Commander-in-Chief of the Colony of New South Wales and its Dependencies.

TO ALL TO WHOM THESE PRESENTS SHALL COME, greeting :

WHEREAS JOSEPH DUKE MACKENZIE and WILLIAM ATCHISON, both of London, England, have by their Petition humbly represented to me that they are the authors or designers of a certain invention or improvement in manufactures, that is to say, of an invention entitled "Improvements in, and relating to, the Glazing of Roofs and other structures," which is more particularly described in the amended specification and the sheet of drawings which are hereunto annexed; and that they, the said Petitioners, have deposited with the Honorable the Treasurer of the said Colony of New South Wales the sum of Twenty Pounds sterling, for defraying the expense of granting these Letters of Registration, as required by the Act of Council, sixteenth Victoria, number twenty-four; and have humbly prayed that I would be pleased to grant Letters of Registration, whereby the exclusive enjoyment and advantage of the said invention or improvement might be secured to them for a period of fourteen years: And I, being willing to give encouragement to all inventions and improvements in the arts or manufactures which may be for the public good, and having received a report favourable to the prayer of the said Petition, from competent persons appointed by me to examine and consider the matters stated therein and to report thereon for my information, am pleased, with the advice of the Executive Council, and in exercise of the power and authority given to me by the said Act of Council, to grant, and do by these Letters of Registration grant unto the said Joseph Duke Mackenzie and William Atchison, their executors, administrators, and assigns, the exclusive enjoyment and advantage of the said invention or improvement, for and during the term of fourteen years from the date hereof; to have, hold, and exercise unto the said Joseph Duke Mackenzie and William Atchison, their executors, administrators, and assigns, the exclusive enjoyment and advantage thereof, for and during and unto the full end and term of fourteen years from the date of these presents next and immediately ensuing, and fully to be complete and ended: Provided always, that if the said Joseph Duke Mackenzie and William Atchison shall not, within three days after the granting of these Letters of Registration, register the same in the proper office in the Supreme Court, at Sydney, in the said Colony of New South Wales, then these Letters of Registration, and all advantages whatsoever hereby granted, shall cease and become void.

In witness whereof, I have hereunto set my sign manual, and have caused the present Letters of Registration to be sealed with the seal of the said Colony of New South Wales, at Government House, Sydney, in New South Wales, this thirteenth day of December, in the year of our Lord one thousand eight hundred and eighty-four.

[L.S.]

AUGUSTUS LOFTUS.

Improvements in Glazing of Roofs and other Structures.

SPECIFICATION of JOSEPH DUKE MACKENZIE and WILLIAM ATCHISON, both of London, England for an invention entitled "Improvements in and relating to the Glazing of Roofs and other structures."

OUR invention relates to the glazing of roofs, conservatories, and other structures, and is designed to enable this operation to be performed without the use of putty or like material.

According to the first part of our improvements we construct a sash-bar with a core of iron or steel, consisting of a central vertical web and lateral grooved or channelled flanges, and with a protective sheath or covering of thin sheet lead, copper, or other ductile metal not subject to corrosion; and apply over this protective covering an outer covering of sheet metal or other glazing material. The non-corrosive covering is applied by rolling or otherwise to the central web or feather of the iron or steel core of the sash-bar and to the groove or channel on each side of the said central web. And the outer covering is formed to overlap the edges of the glass when the same are placed on the flanges of the bar.

According to the second part of our invention, instead of covering the central web (which forms part of our improved sash-bar) entirely with this metal covering or packing, we apply to the same, as hereinafter specified, a cap, which may be formed of sheet-lead, zinc, or other metal, or of vulcanite, wood, papier-mache, or the like, but which we prefer to form either entirely or partially of asbestos. In some cases, instead of forming the cap of asbestos, we line it or pack the flanges thereof with asbestos, as we have found this material especially advantageous for the purposes of our invention, as it enables us to use our improved sash-bar in such a manner as to ensure permanently tight joints between the framework and the sheets of glass used in glazed roofs or other structures. In some instances we extend the asbestos or other non-metallic packing from the lower surface of the said cap to the parts of the frame below the glass instead of employing the ductile metal packing.

The cap of the sash-bar is designed to be placed over the upper part of the central web after the glass has been placed on the upper edges of the flanges of the said bar, and we form such cap or covering with lateral wings or flanges to extend over the edges or portions of the glass lying on the bar. In this case we secure the cap by a screw or stud, which may be fitted in a dovetailed notch in the web of the bar, the said screw being passed through the cap and secured by a nut or by riveting. In some cases we secure the cap of the sash-bar by pins or projections, as hereinafter described. The cap or covering then serves not only to protect the iron or steel core and prevent the access of water or moisture thereto, but also retains the glass in its place, when it would otherwise be liable in stormy weather to vibrate and loosen the asbestos or other glazing-strips employed. As the cap or covering thus serves to secure the glass, it is obvious that when we use, in combination therewith, the sheet metal covering for the lateral wings and lower part of the core, this covering may be carried up the sides of the central web without being turned over upon the edges of the glass sheets, the whole forming a modification of our improved sash-bar, which we have found very efficient.

We may employ the asbestos for roofing or similar purposes otherwise than in connection with a cap, and either alone or in combination with other materials (for example, India-rubber, cotton, or the like), and either in the form of woven fabric, cord, or mill-board, or otherwise. We apply the asbestos or the compound containing the same as packing between the glass and the frame, sash-bar, or other adjunct, such as a cap or cover for the frame or bar. The said frame, sash-bar, or the like may be of metal, wood, or other suitable material.

The manner of carrying our invention into practice is illustrated in the accompanying drawing, which shows in transverse section parts of a roof constructed according to our improvements.

A is the core of the sash-bar. The aforesaid non-corrosive and protective sheath or covering B and the lead or other ductile glazing material B', forming the subject of the first part of our invention, are applied to the said sash-bar, as shown in fig. 1.

The cap C, which is used as above described, according to the second part of our invention, as shown in fig. 2, is secured at intervals by means of screws or other suitable means to the core A.

This cap, as above stated, may be formed of zinc, lead, iron, or other metal, or partly of metal and partly of other material, or entirely of non-metallic material, such as asbestos, vulcanite, papier-mache, or the like.

When we employ asbestos, vulcanite, or like material, in combination with metal, such material, in some instances, forms a structural portion of the cap, and in other instances is placed between the cap or the bar and the glass D, in such a manner as to effect the purpose above stated, viz., the making of a secure and tight joint between the glass and the frame. In cases where a non-metallic packing, such as asbestos or vulcanite, is used above and below, or above or below the glass in conjunction with the cap C, we can entirely dispense with the soft ductile sheet metal covering B'.

In fig. 2 we have shown the cap constructed of metal and faced or packed with asbestos, vulcanite, or the like, on the surfaces *c* where the joints have to be made tight.

The cap shown in fig. 3 is preferably formed of sheet zinc, iron, or steel, or similar flexible material, and has its lower edge turned inward; this lower or inner edge bears against a pin or projection at E, which prevents the rising or displacement of the cap. This cap, instead of being constructed of metal, may be formed of, or partially of, asbestos, vulcanite, or the like, or used with the asbestos or similar packing, as described with reference to fig. 2, and with or without the protective non-corrosive covering shown in fig. 1.

It will be understood that we do not limit ourselves to the use of the particular sectional form of the sash-bars shown in the drawing, but may make the same of any suitable or convenient form in transverse section.

According to another method we take a sash-bar, having a groove in one or both sides to receive the glass, which bar may be of cast-iron or wood, or it may be a hollow bar of sheet-zinc. In the lower part of the groove we place a piece of asbestos, mill-board, tape, or the like, upon which we lay the glass. We then force asbestos fibre, either alone or in combination with other materials, into the groove above the glass so as to hold the same firmly in place.

We can, moreover, employ the asbestos, or a compound thereof, for the purposes of our invention in other manners than those above described. The

Improvements in Glazing of Roofs and other Structures.

The employment of asbestos, in addition to rendering the roofs or other glazed parts of a building waterproof, and providing a cushion for the glass to diminish the liability to breakage of the same by shocks or jars, enables us to make a joint which will permit the expansion and contraction of the metal or the glass, or both, without causing leakage of the said joint.

What we claim is—

First—The modification of our improved sash-bar, consisting of a solid core of any section and a protective cap or covering enveloping the web or ridge of the bar, and formed of, or partially of, or combined with, vulcanite, asbestos, or a compound thereof, or other suitable packing material, substantially as described and illustrated in figs. 2 and 3, and used for the purposes set forth.

Second—The employment of asbestos, or a compound thereof, in glazed roofs or other structures, substantially as and for the purposes specified.

In witness whereof, we, the said Joseph Duke Mackenzie and William Atchison, have hereunto set our hands and seals, this 25th day of August, 1884.

JOS. D. MACKENZIE.
WILLIAM ATCHISON.

Witness—

HENRY H. LARE.

This is the amended specification referred to in the annexed Letters of Registration granted to Joseph Duke Mackenzie and William Atchison, the 30th day of December, A.D. 1884.

AUGUSTUS LOFTUS.

REPORTS.

Sir,

Sydney, 15 October, 1884.

The application of Messrs. Mackenzie and Atchison, for Letters of Registration for an invention entitled "Improvements in, and relating to, the Glazing of Roofs and other structures," having been referred to us, we have examined the plans and specification accompanying the same, and have now the honor to report that we see no objection to the issue of Letters of Registration to the second and third claims, but that we consider the first claim is similar to that granted to Mr. W. P. Lester, in September last, and therefore should not be allowed.

We have, &c.,

JAMES BARNET.
EDMUND FOSBERY.

The Under Secretary of Justice.

Sir,

Sydney, 21 November, 1884.

The amended application of Messrs. Mackenzie and Atchison, for Letters of Registration for an invention entitled "Improvements in, and relating to, the Glazing of Roofs and other structures," having been referred to us for report, we now see no objection to the issue of Letters of Registration as prayed for.

We have, &c.,

JAMES BARNET.
EDMUND FOSBERY.

The Under Secretary of Justice.

[Drawings—one sheet.]

Fig. 1.

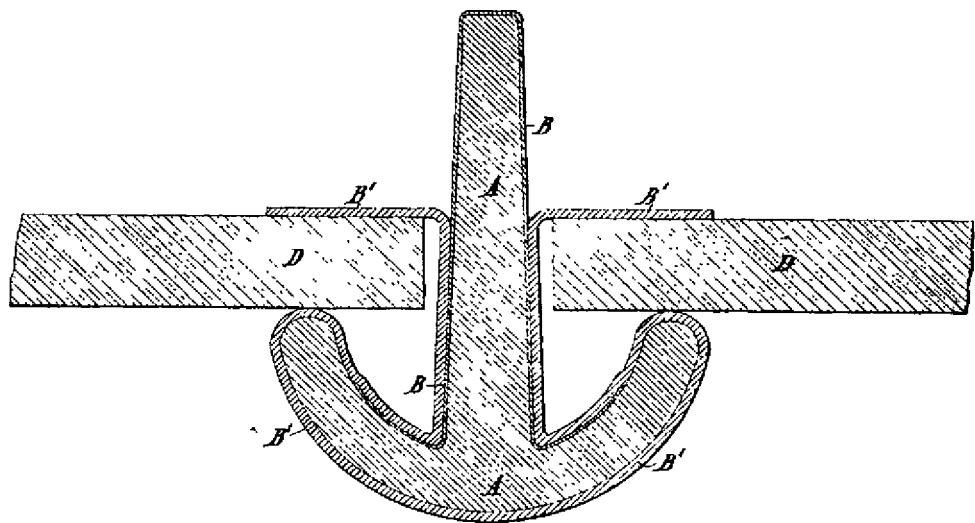


Fig 2

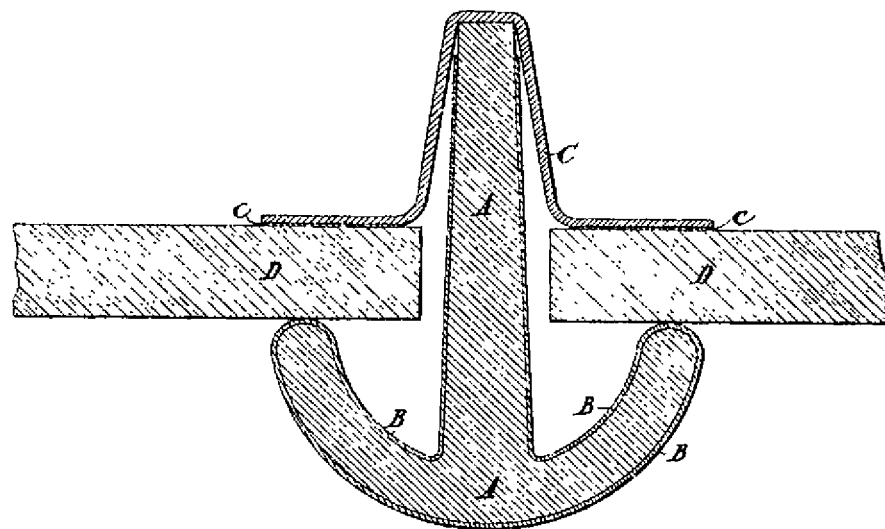
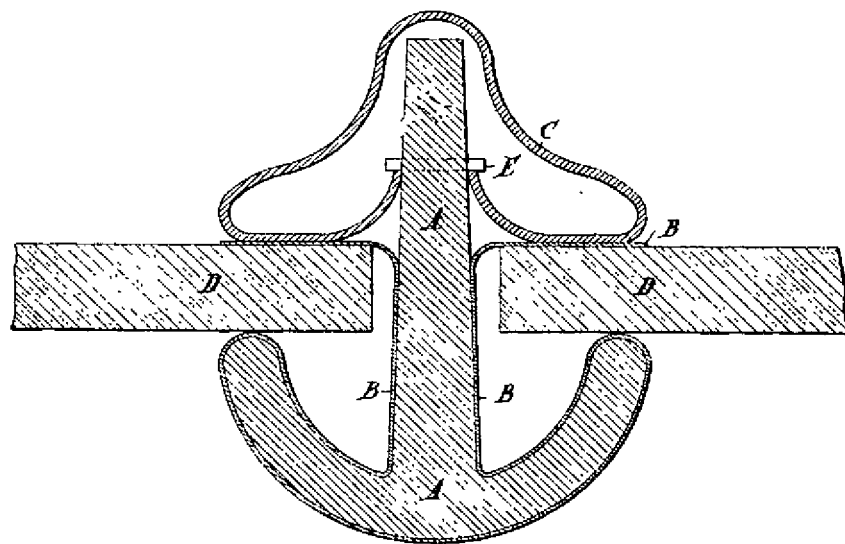


Fig. 3



*This is the Sheet of Drawings referred to in the annexed
Letters of Registration, granted to Joseph Duke Mackenzie,
and William Atchison, the thirtieth day of December, A.D. 1884.*

Augustus Loftus.

PHOTO-LITHOGRAPHED AT THE GOVT. PRINTING OFFICE,
SYDNEY, NEW SOUTH WALES.

(Sig 245-)



A.D. 1884, 30th December. No. 1552.

IMPROVEMENTS IN SURFACE CONDENSERS AND HEATERS, &c.

LETTERS OF REGISTRATION to John Kirkaldy, for Improvements in Surface Condensers and Heaters, and apparatus for supplying heated feed-water to the boilers of steam-engines.

[Registered on the 30th day of December, 1884, in pursuance of the Act 16 Vic. No. 24.]

BY HIS EXCELLENCY THE RIGHT HONORABLE SIR AUGUSTUS WILLIAM FREDERICK SPENCER LOFTUS (commonly called LORD AUGUSTUS LOFTUS), Knight Grand Cross of the Most Honorable Order of the Bath, a Member of Her Majesty's Most Honorable Privy Council, Governor and Commander-in-Chief of the Colony of New South Wales and its Dependencies.

TO ALL TO WHOM THESE PRESENTS SHALL COME, greeting :

WHEREAS JOHN KIRKALDY, of 40, West India Dock Road, Poplar, in the county of Middlesex, England, engineer, hath by his Petition humbly represented to me that he is the author or designer of a certain invention or improvement in manufactures, that is to say, of an invention entitled "Improvements in Surface Condensers and heaters, and apparatus for supplying heated feed-water to the boilers of steam-engines," which is more particularly described in the specification, marked "A," and the two sheets of drawings marked "B" and "C" respectively, which are hereunto annexed ; and that he, the said Petitioner, hath deposited with the Honorable the Treasurer of the said Colony of New South Wales the sum of Twenty Pounds sterling, for defraying the expense of granting these Letters of Registration, as required by the Act of Council, sixteenth Victoria, number twenty-four ; and hath humbly prayed that I would be pleased to grant Letters of Registration, whereby the exclusive enjoyment and advantage of the said invention or improvement might be secured to him for a period of fourteen years : And I, being willing to give encouragement to all inventions and improvements in the arts or manufactures which may be for the public good, and having received a report favourable to the prayer of the said Petition, from competent persons appointed by me to examine and consider the matters stated therein and to report thereon for my information, am pleased, with the advice of the Executive Council, and in exercise of the power and authority given to me by the said Act of Council, to grant, and do by these Letters of Registration grant unto the said John Kirkaldy, his executors, administrators, and assigns, the exclusive enjoyment and advantage of the said invention or improvement for and during the term of fourteen years from the date hereof ; to have, hold, and exercise unto the said John Kirkaldy, his executors, administrators, and assigns, the exclusive enjoyment and advantage thereof, for and during and unto the full end and term of fourteen years from the date of these presents next and immediately ensuing, and fully to be complete and ended : Provided always, that if the said John Kirkaldy shall not, within three days after the granting of these Letters of Registration, register the same in the proper office in the Supreme Court, at Sydney, in the said Colony of New South Wales, then these letters of Registration, and all advantages whatsoever hereby granted, shall cease and become void.

In witness whereof, I have hereunto set my sign manual, and have caused the present Letters of Registration to be sealed with the seal of the said Colony of New South Wales, at Government House, Sydney, in New South Wales, this thirtieth day of December, in the year of our Lord one thousand eight hundred and eighty-four.

[L.S.]

AUGUSTUS LOFTUS.

Improvements in Surface Condensers and Heaters, &c.

A.

SPECIFICATION of JOHN KIRKALDY, of 40, West India Dock Road, Poplar, in the county of Middlesex, England, engineer, for an invention entitled "Improvements in Surface Condensers and Heaters, and apparatus for supplying heated feed-water to the boilers of steam-engines."

In surface condensers for obtaining fresh water by distillation, I form the condenser of a cylindrical case closed at the top with a suitable cover; a steam pipe fitted with a cock is led down through the centre of the cover, and below the cover any desired number of nozzles are made to branch out radially from it. To each nozzle I attach the upper end of an upright helical worm.

The several worms at their lower ends are made to open into a compartment at the bottom of the case in which a filter-bed is contained. Cooling water is passed into the bottom of the upper compartment, and is allowed to flow off from it at the top.

Steam is admitted to the upper ends of the coils by the steam-cock, and fresh water passes from the lower ends of the coils on to the top of the filter-bed.

Preferably I make each tubular coil from a solid drawn tube of copper, having longitudinal corrugations formed in it, but the tubes might be of other section and be either brazed or solid drawn.

Figures 1, 2, 3, and 4 of the drawings show the way in which I prefer to construct the condenser.

Figure 1 is a vertical section, and

Figure 2 a side elevation of the condenser.

Figure 3 is a plan view, partly in section of the top of the condenser, and

Figure 4 a horizontal cross-section, taken on the line 11, of figure 1.

Figure 5 is a cross-section on a larger scale of one of the tubes from which the tubular coils are formed.

AA is the upper compartment of the casing, B the lower compartment, C is the steam-pipe led down through the cover of the upper compartment A, and has nozzles projecting radially from it, to each of which is connected the upper end of a tubular coil D.

In the arrangement shown, the coils are arranged in pairs, one within the other, in order that a greater extent of cooling surface may be contained in a condenser of given size.

The lower ends of the several coils are led separately through the bottom of the compartment A, and open directly into the compartment B.

F is a pipe by which a stream of water can be admitted to the lower end of the compartment A, and G is a pipe by which water can flow off from the upper end of this compartment.

In order also to ensure that each of the several coils grouped around the central steam-pipe C shall have a uniform stream of water brought into contact with it, the central portion of the compartment A is composed of separate tubular columns, each containing one pair of tubular coils. At the bottom of the compartment below these tubular coils are divisions arranged in the way shown at figure 4, to ensure that an equal supply of water from the water inlet F shall be supplied to the lower end of each column.

H is a filter-bed resting on a perforated arched plate at the bottom of the compartment B.

I is a perforated plate placed above the top of the filter-bed.

J is an outlet pipe for carrying off filtered water from below the filter-bed.

When the condenser is to be used for condensing exhaust steam from a steam engine, I prefer to form the condenser in the manner shown at figures 6, 7, 8 and 9.

In this construction the tubular coils are made, as will be seen by the drawings, alternately right and left handed, so that they may interlock one with the other, and admit of as many tubular coils as practicable being enclosed within a casing of given dimensions, whilst at the same time the spaces between the parts of the several coils are kept uniform so that the water used for cooling the exterior of the tubes can have ready access to all parts of the exterior of each tube.

Figure 6 is a vertical elevation, one-half in section of the outer casing of the condenser.

Figure 7 is a vertical elevation of the condenser with the outer case in section.

Figure 8 is a plan view of the cover of the casing, and

Figure 9 is a plan view of the condenser with the top cover and tube plate removed.

A is the outer casing within which the several tubular coils are contained, B is a steam chamber above the top of the casing A, C is a chamber for condensed water below the bottom of the casing A, D are spiral worms passing at their upper ends through the top of the tube-plate E, and at their lower ends, through the bottom of the tube-plate F.

It will be seen that the coils are alternately right and left handed, and that the coils of one worm pass into the spaces between the coils of the worms which are on either side of it.

G is an inlet pipe for admitting water to the lower part of the casing A through holes G¹ formed in it, as shown at figure 6.

H is an outlet by which water can pass away from the upper part of the casing A. A side outlet is also formed from the chamber C to allow of condensed water being drawn off from it. This side outlet is not shown in the drawings.

For condensers of larger dimensions a greater number of circles of tubular coils may be arranged concentrically, one within the other, as illustrated at figures 10 and 11.

In these figures the same letters of reference are used as in figures 6, 7, 8, and 9.

For condensing steam from high-pressure steam-engines so as to obtain a supply of heated feed-water, or to avoid the discharge of steam into the air, I form the condenser in the manner shown at figures 12 and 13. In this case the tubular coils are cooled by water being passed through them, instead of on their exterior, whilst the steam to be condensed is admitted to the interior of the outer casing.

Figure 12 is a vertical section of the casing of the condenser. The tubular worms are not shown in this figure.

Figure 13 is a plan view of the condenser partly in section.

A is the cylindrical casing closed at each end by a cover B.

On the exterior of each cover B is another cover C, arched, so as to form a water chamber. To the lower

Improvements in Surface Condensers and Heaters, &c.

lower chamber water is admitted through an inlet C¹, and after passing through the several coils and into the upper water chamber is allowed to pass away through the outlet C².

Each cover B has a cylindrical neck at the centre projecting from either side of it. The ends of the necks which extend inwards into the chamber A are closed, and side openings are made to allow steam to pass to or from them. The end of each neck, which extends outwards from the cover B, passes through the cover C, and has a screw thread cut upon it, as shown at figure 12. A flanged nut D is made to screw on to this screw thread and bear against the top of the cover C, so as to form a tight joint.

The flanged nut D at the lower end of the condenser is connected to the exhaust pipe from the steam-engine, so that steam enters by it into the casing A.

Any steam uncondensed in the casing A can pass off through the tubular neck at the top of the condenser to a pipe open to the air.

An outlet F for condensed water is provided from the lower part of the casing A, by which water obtained by the condensation of the steam can pass to the feed-water tank.

When the apparatus is to be used only for heating the feed-water supplied to a steam-boiler, I form it as shown at figures 14 and 15. This construction varies but little from the construction shown at figures 12 and 13, except that the tubular necks extending from the interior of the casing A are done away with, and that, instead of water being passed through the tubular coils, I cause the coils to be heated by passing steam through them, whilst the feed-water to be heated is passed through the outer casing A, in its passage from the feed-pump of the engine to the boiler.

By constructing the heater in the above-described manner it can be applied to the feed-pipe to any boiler or set of boilers simply by cutting out a length of the feed-pipe and inserting the heater in its place.

In cases also where, as in marine engines, the main engines are not always in use, and where a donkey engine is employed for pumping and effecting other work, I so arrange the connections to and from the feed heater that all water supplied to the boilers of the main engines must of necessity be passed through the heater, so that the boilers may be supplied with heated water, not only during the time that the main engines are running, but also at the time when the boilers are being filled by pumps worked by the donkey engine when the main engines are not at work.

For this purpose I lead a branch pipe from the pump worked by the donkey engine into the feed-pipe passing from the feed-pump of the main engines to the heater, and I provide cocks, or it may be a single three-way cock, at the junction of the pipes, by means of which the water supplied by the donkey pump may be admitted to the feed-heater, and shut off from the feed-pump of the main engine, or may be opened from the feed-pump of the main engine and closed to the donkey pump.

Into the steam-pipe for supplying steam to one end of the heater from the main boilers I also lead a branch pipe from the boiler of the donkey engine, and provide cocks or a single three-way cock at the junction of the pipes, so that steam may be supplied to the heater, either from the boiler by which the donkey engine is supplied with steam, or from the main boilers which supply steam to the main engines. From the other end of the heater a pipe is led away to the hot well of the main engines. Any steam which may pass through the heater uncondensed, and any water produced by the condensation of the steam, will so be brought into the hot well.

At figure 16 I have shown a plan view of a marine engine having a feed-heater supplied to the feed-pipe of its boilers in the above manner.

A is the feed-heater, B the feed-pipe from the main engines, C the feed-pipe from the donkey engines, D a three-way cock at the junction of the pipes, E the feed-pipe passing from the heater to the main boilers, F a steam-pipe passing from the main boilers to the donkey engine and to one end of the feed-heater, G a steam-pipe leading from the boiler of the donkey engine into the steam-pipe F, H is a pipe leading from the opposite end of the feed-heater to the hot well of the main engines to convey to it any water produced by the condensation of steam in the tubular coils of the heater.

Having now described my invention, and the manner in which the same is to be performed, I declare that what I claim is:—

- First—The construction of apparatus for obtaining fresh water by distillation, substantially in the manner hereinbefore described, with reference to figures 1, 2, 3, and 4 of the drawings annexed.
 - Second—The construction of coolers or condensers and heaters, substantially in the manner hereinbefore described, with reference to figures 6, 7, 8, and 9.
 - Third—The construction of coolers or condensers and heaters with the cooling or heating surface, composed of alternately right and left handed spiral worms erected parallel with one another, and with the coils of each worm passing into the spaces between the coils of the worms on either side of it, substantially as described.
 - Fourth—The construction of coolers or condensers and heaters, substantially in the manner hereinbefore described, with reference to figures 10 and 11.
 - Fifth—The construction of heaters and condensers for condensing exhaust steam from high pressure steam-engines, substantially in the manner hereinbefore described, with reference to figures 12 and 13.
 - Sixth—The construction of feed-water heaters for supplying heated feed-water to the boilers of steam-engines, substantially in the manner hereinbefore described, with reference to figures 14 and 15.
 - Seventh—The combination or arrangement of parts, substantially in the manner hereinbefore described, with reference to figure 16, whereby the feed-water supplied to the boilers of steam-engines may not only be heated when the feed-water is fed to the boilers by the feed-pump of the engines, but also when it is fed to the boilers from a pump worked by a donkey engine.
- In witness whereof, I, the said John Kirkaldy, have hereunto set my hand and seal, this twenty-sixth day of September, one thousand eight hundred and eighty-four.

JNO. KIRKALDY.

This is the specification, marked A, referred to in the annexed Letters of Registration granted to John Kirkaldy, the thirtieth day of December, A.D. 1884.

AUGUSTUS LOFTUS.
REPORT.

Improvements in Surface Condensers and Heaters, &c.

REPORT.

Sir,

In reply to your communication of the 3rd instant, we have the honor to report that we have examined Mr. John Kirkaldy's application for Letters of Registration, also specification and drawings of an invention entitled "Improvements in Surface Condensers and Heaters, and apparatus for supplying feed-water to the boilers of steam-engines," and see no reason why it should not be granted.

Sydney, 28 November, 1884.

We have, &c.,
FRANCIS HIXSON.
H. BRODERICK.

The Under Secretary of Justice.

[Drawings—two sheets.]

Fig. 13.

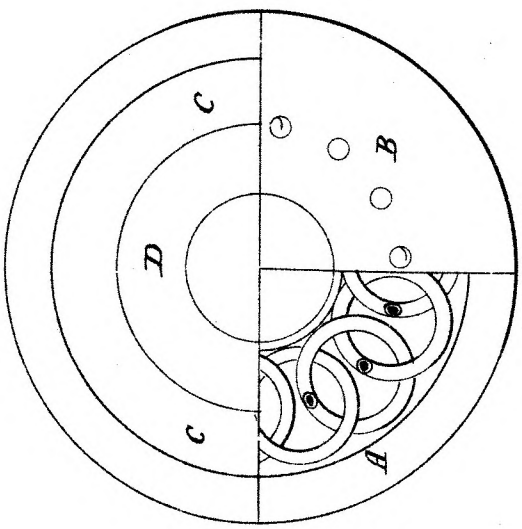


Fig. 15.

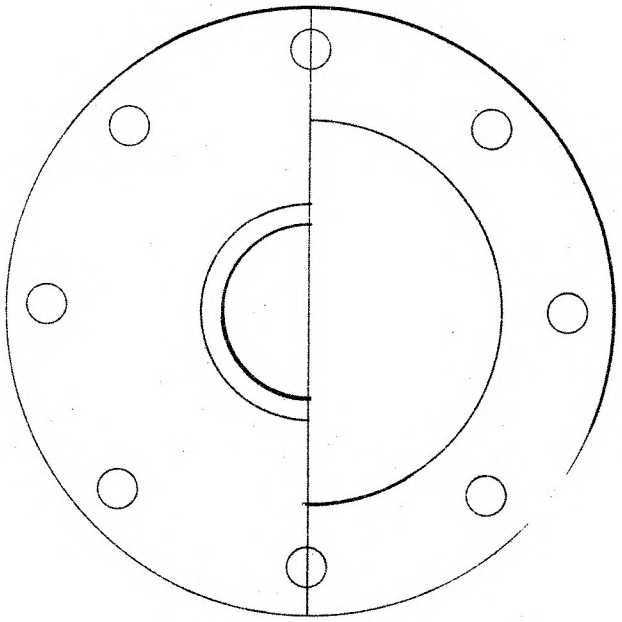


Fig. 12.

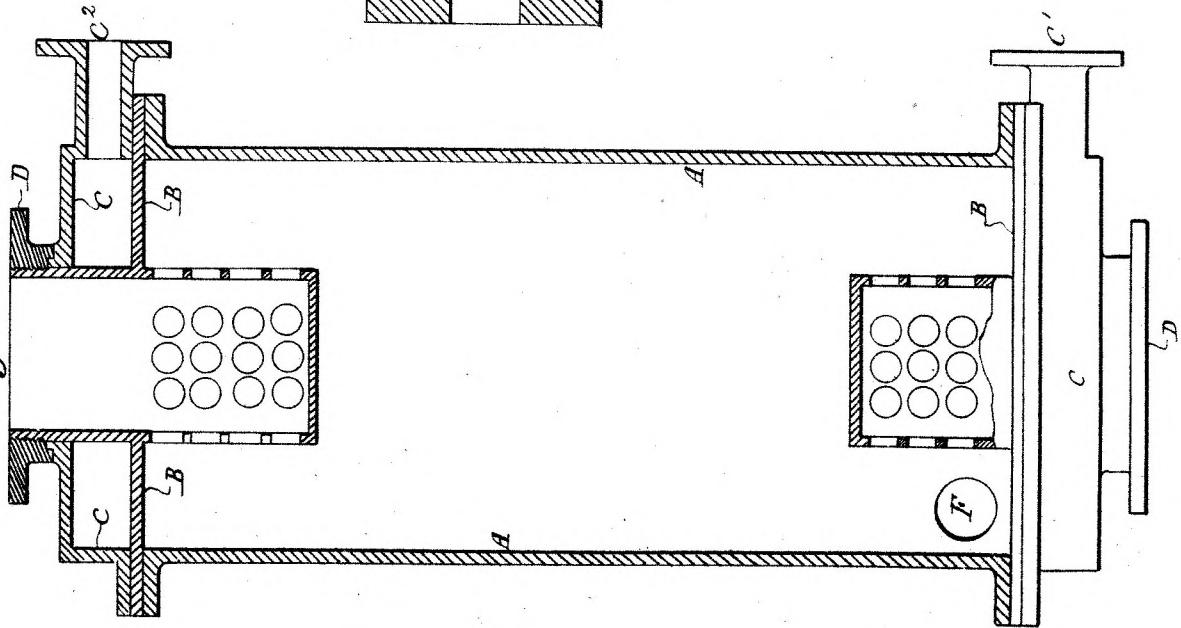


Fig. 1A.

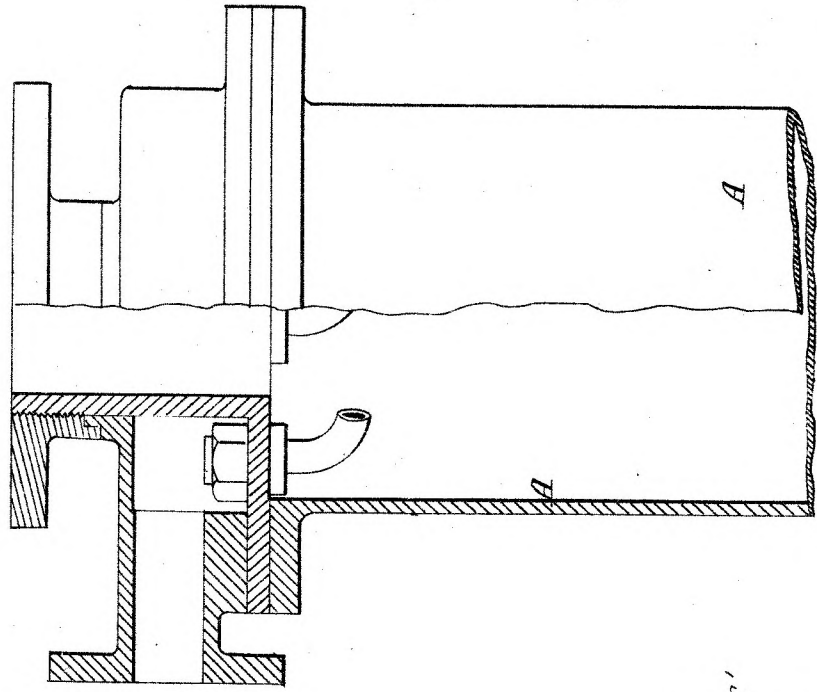
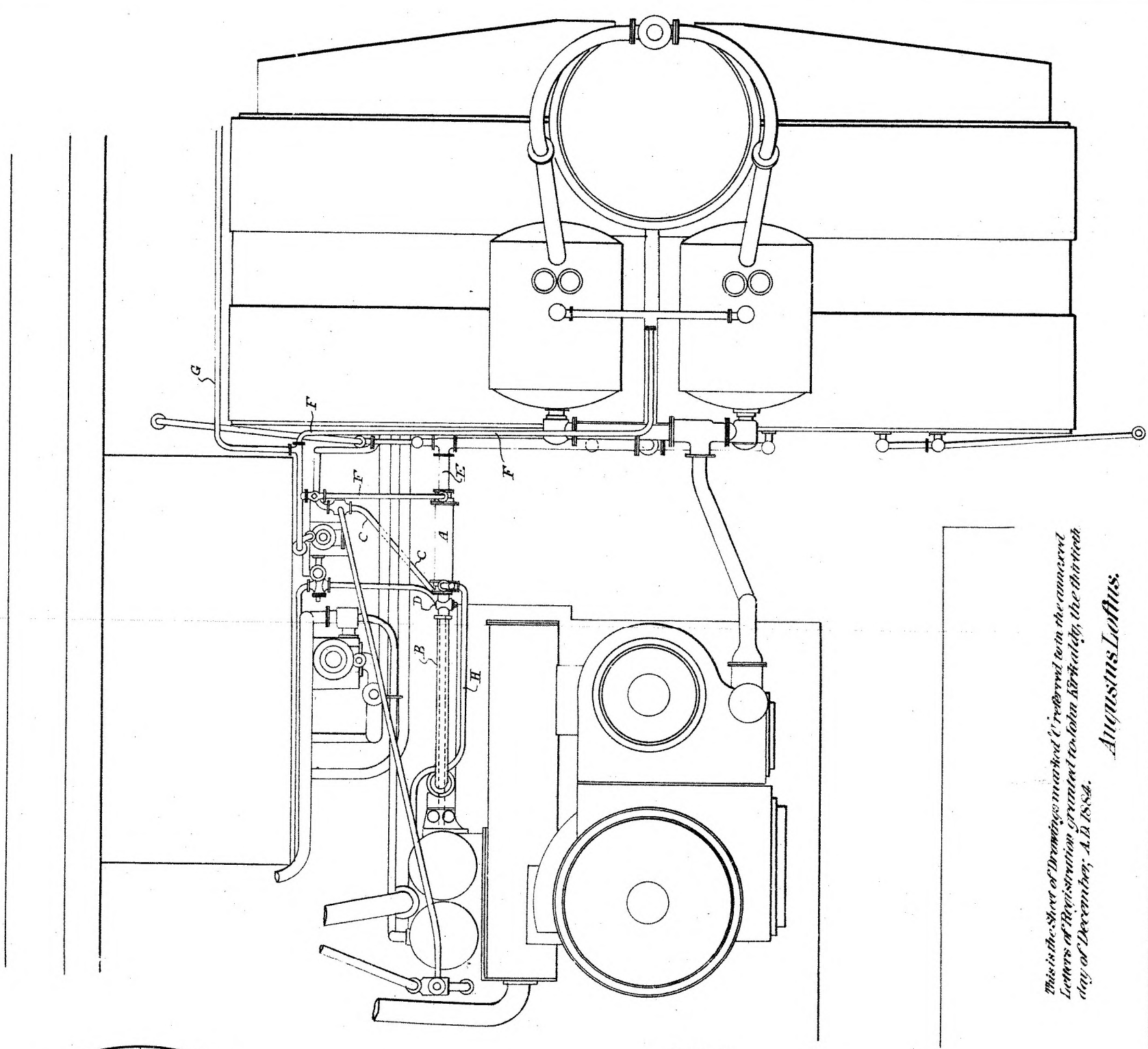
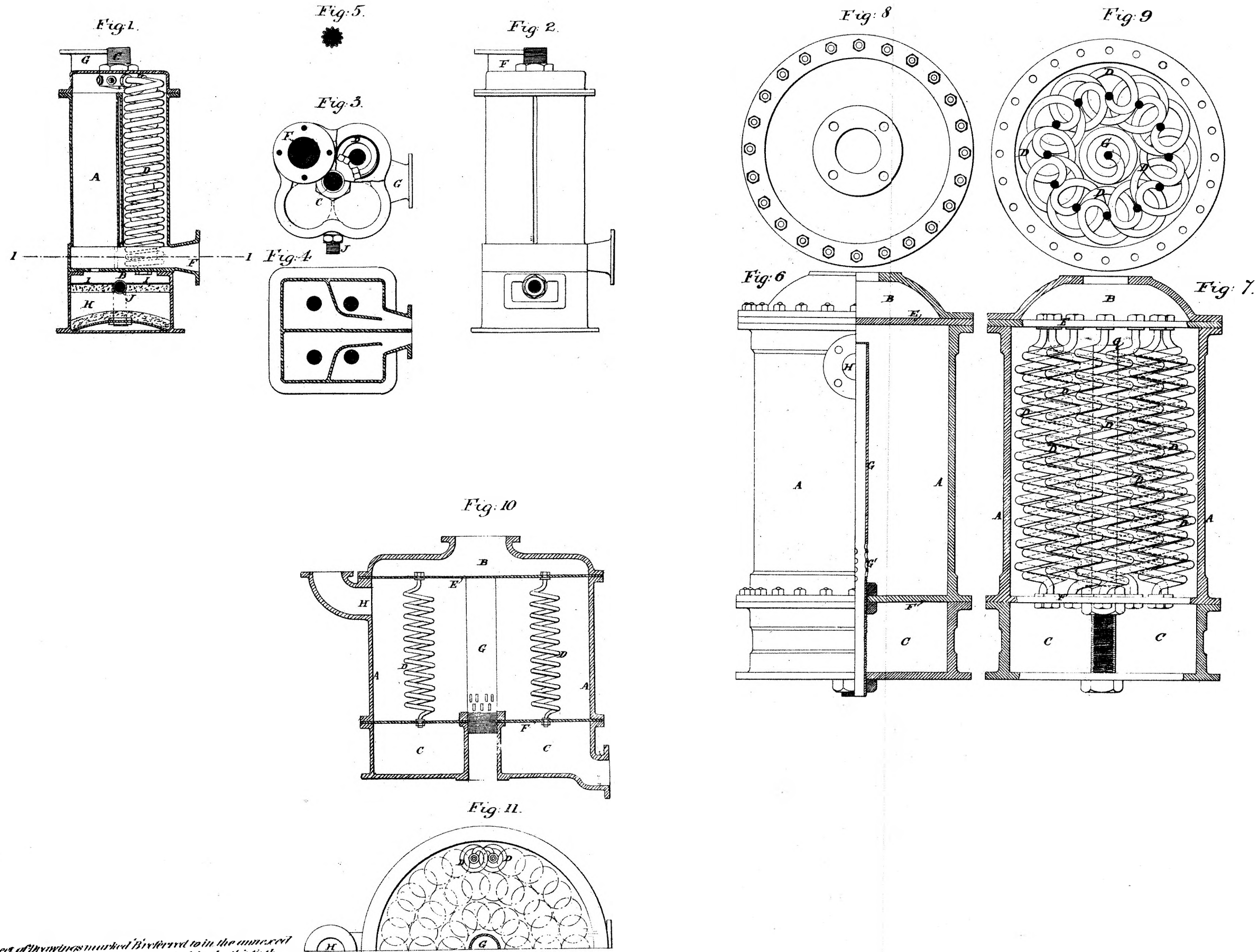


Fig. 16.



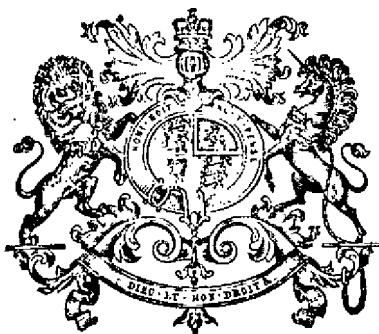
This is the best of Drawings marked C referred to in the amended Letters of Registration granted to John B. H. Kelly, the inventor, on the 10th day of December, A.D. 1884.

Augustus Loftis.



This is the Sheet of Drawings marked B, referred to in the annexed Letters of Registration granted to John Kirkaldy, the thirtieth day of December, A.D. 1884.

Augustus Loftus.



A.D. 1884, 30th December. No. 1553.

AN IMPROVED FURNACE FOR SMELTING ORES.

LETTERS OF REGISTRATION to John B.-Gafford, for an Improved Furnace for smelting Ores.

[Registered on the 30th day of December, 1884, in pursuance of the Act 16 Vic. No. 24.]

BY HIS EXCELLENCY THE RIGHT HONORABLE SIR AUGUSTUS WILLIAM FREDERICK SPENCER LOFTUS (commonly called LORD AUGUSTUS LOFTUS), Knight Grand Cross of the Most Honorable Order of the Bath, a Member of Her Majesty's Most Honorable Privy Council, Governor and Commander-in-Chief of the Colony of New South Wales and its Dependencies.

TO ALL TO WHOM THESE PRESENTS SHALL COME, greeting :

WHEREAS JOHN B.-GAFFORD, of 129, Pitt-street, Sydney, in the Colony of New South Wales, smelter and refiner, hath by his Petition humbly represented to me that he is the author or designer of a certain invention or improvement in manufactures, that is to say, of an invention entitled "The Improved Furnace for smelting Ores," which is more particularly described in the specification and sheet of drawings which are hereunto annexed; and that he, the said Petitioner, hath deposited with the Honorable the Treasurer of the said Colony of New South Wales the sum of Twenty Pounds sterling, for defraying the expense of granting these Letters of Registration, as required by the Act of Council, sixteenth Victoria, number twenty-four; and hath humbly prayed that I would be pleased to grant Letters of Registration, whereby the exclusive enjoyment and advantage of the said invention or improvement might be secured to him for a period of fourteen years; and I, being willing to give encouragement to all inventions and improvements in the arts or manufactures which may be for the public good, and having received a report favourable to the prayer of the said Petition, from competent persons appointed by me to examine and consider the matters stated therein and to report thereon for my information, am pleased, with the advice of the Executive Council, and in exercise of the power and authority given to me by the said Act of Council, to grant, and do by these Letters of Registration grant unto the said John B.-Gafford, his executors, administrators, and assigns, the exclusive enjoyment and advantage of the said invention or improvement, for and during the term of fourteen years from the date hereof; to have, hold, and exercise unto the said John B.-Gafford, his executors, administrators, and assigns, the exclusive enjoyment and advantage thereof, for and during and unto the full end and term of fourteen years from the date of these presents next and immediately ensuing, and fully to be complete and ended: Provided always, that if the said John B.-Gafford shall not, within three days after the granting of these Letters of Registration, register the same in the proper office in the Supreme Court, at Sydney, in the said Colony of New South Wales, then these Letters of Registration, and all advantages whatsoever hereby granted, shall cease and become void.

In witness whereof, I have hereunto set my sign manual, and have caused the present Letters of Registration to be sealed with the seal of the said Colony of New South Wales, at Government House, Sydney, in New South Wales, this thirtieth day of December, in the year of our Lord one thousand eight hundred and eighty-four.

[L.S.]

AUGUSTUS LOFTUS.

Improved Furnace for smelting Ores.

I, JOHN B.-GAFFORD, of Sydney, smelter and refiner, being the inventor of an "Improved Furnace for smelting gold, silver, copper, lead, and other ores," do hereby declare and specify the particulars of my invention to be as follows:—

THIS invention consists of an improved water-jacket which is constructed to carry a steam pressure up to 60 lb. to the square inch, causing a saving of fuel from 12 to 15 per cent., thereby rendering the charges of ores less liable to cake or crust.

1st. The jacket consists of a casing of iron, steel, or any suitable metal, surrounding the body of the furnace shown at A, fig. 1, from the crucible to the feed doors; the upper portion of the jacket is supplied with four or more spring valves for receiving the pressure if over 60 lb. to the square inch, marked B, fig. 1.

2nd. There are also four or more perforated sprays marked C, fig. 1, for the purpose of condensing the fumes or to arrest the escape of any portion of the metals in finely-divided particles.

Having now described my invention, I claim—

First—The improved jacket as shown in figs. 1 and 2 in the accompanying drawings.

Second—The sprays for condensing the fumes, and arresting fine particles of metals passing up the condensing flue.

In witness thereof, I have hereunto set my hand, this twenty-seventh day of October, one thousand eight hundred and eighty-four.

J. B.-GAFFORD.

Witness—

GEO. M. MARSH.

This is the specification referred to in the annexed Letters of Registration granted to John B.-Gafford, the 30th day of December, A.D. 1884.

AUGUSTUS LOFTUS.

REPORT.

Sir, We do ourselves the honor to report, in reply to your blank cover of the 1st instant, transmitting Mr. John B.-Gafford's Petition for the registration of an invention entitled "The Improved Furnace for smelting Ores," that we are of opinion the prayer of the petitioner may be granted in terms of his specification, drawings, and claim.

Sydney, 21 November, 1884.

We have, &c.,

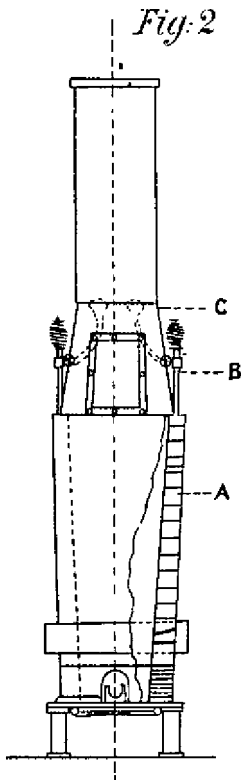
E. C. CRACKNELL.
GOTHER K. MANN.

The Under Secretary of Justice.

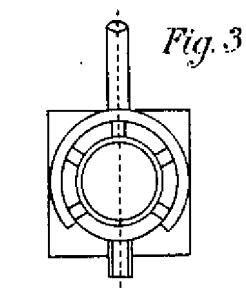
[Drawings—one sheet.]

No. 1554.

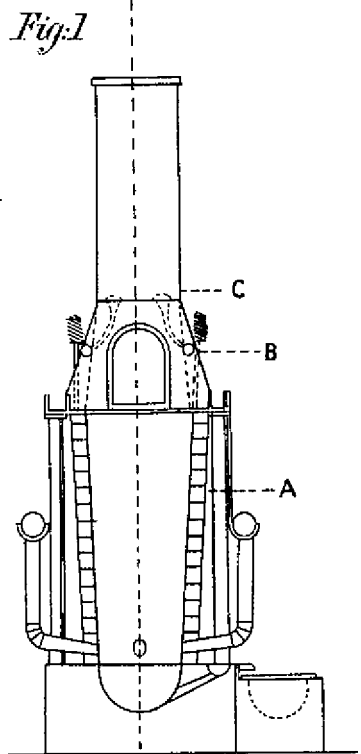
[Assignment of No. 818. See Letters of Registration for 1880, page 91.]



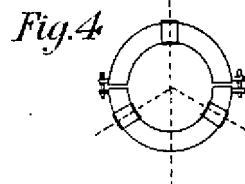
GAFFORD'S
Steam Water Jacket Smelting
FURNACE



for Copper Ore.



GAFFORD'S
Steam Water Jacket Smelting
FURNACE



for Gold, Silver, and Lead Ores.

This is the Sheet of Drawings referred to in the annexed Letters of Registration, granted to John B. Gifford, the thirtieth day of December: A. D. 1884.

Augustus Loftus.



A.D. 1884, 30th December. No. 1555.

THE IMPROVED ROASTING FURNACE.

LETTERS OF REGISTRATION to John B.-Gafford, for The Improved Roasting Furnace.

[Registered on the 31st day of December, 1884, in pursuance of the Act 16 Vic. No. 24.]

BY HIS EXCELLENCY THE RIGHT HONORABLE SIR AUGUSTUS WILLIAM FREDERICK SPENCER LOFTUS (commonly called LORD AUGUSTUS LOFTUS), Knight Grand Cross of the Most Honorable Order of the Bath, a Member of Her Majesty's Most Honorable Privy Council, Governor and Commander-in-Chief of the Colony of New South Wales and its Dependencies.

TO ALL TO WHOM THESE PRESENTS SHALL COME, greeting :

WHEREAS JOHN B.-GAFFORD, of 129, Pitt-street, Sydney, in the Colony of New South Wales, smelter and refiner, hath by his Petition humbly represented to me that he is the author or designer of a certain invention or improvement in manufactures, that is to say, of an invention entitled "The Improved Roasting Furnace," which is more particularly described in the specification and the sheet of drawings which are hereunto annexed; and that he, the said Petitioner, hath deposited with the Honorable the Treasurer of the said Colony of New South Wales the sum of Twenty Pounds sterling, for defraying the expense of granting these Letters of Registration, as required by the Act of Council, sixteenth Victoria, number twenty-four; and hath humbly prayed that I would be pleased to grant Letters of Registration, whereby the exclusive enjoyment and advantage of the said invention or improvement might be secured to him for a period of fourteen years: And I, being willing to give encouragement to all inventions and improvements in the arts or manufactures which may be for the public good, and having received a report favourable to the prayer of the said Petition, from competent persons appointed by me to examine and consider the matters stated therein and to report thereon for my information, am pleased, with the advice of the Executive Council, and in exercise of the power and authority given to me by the said Act of Council, to grant, and do by these Letters of Registration grant unto the said John B.-Gafford, his executors, administrators, and assigns, the exclusive enjoyment and advantage of the said invention or improvement, for and during the term of fourteen years from the date hereof; to have, hold, and exercise unto the said John B.-Gafford, his executors, administrators, and assigns, the exclusive enjoyment and advantage thereof, for and during and unto the full end and term of fourteen years from the date of these presents next and immediately ensuing, and fully to be complete and ended: Provided always, that if the said John B.-Gafford shall not, within three days after the granting of these Letters of Registration, register the same in the proper office in the Supreme Court, at Sydney, in the said Colony of New South Wales, then these Letters of Registration, and all advantages whatsoever hereby granted, shall cease and become void.

In witness whereof, I have hereunto set my sign manual, and have caused the present Letters of Registration to be sealed with the seal of the said Colony of New South Wales, at Government House, Sydney, in New South Wales, this thirtieth day of December, in the year of our Lord one thousand eight hundred and eighty-four.

[L.S.]

AUGUSTUS LOFTUS.

The Improved Roasting Furnace.

SPECIFICATION.

I, JOHN B.-GAFFORD, of Sydney, smelter and refiner, being the inventor of an improved furnace for smelting gold, silver, copper, lead, and other ores, do hereby declare and specify the particulars of my invention to be as follows :—

AN improved roasting furnace, consisting of one or more fire-clay chambers, marked A A A A ; fig. 1, for protecting the ores from direct contact with the fire, and each chamber is provided with a number of perforations, marked B B, fig 2, to admit of the escape of water gasses, and is also supplied with hoppers, marked C, figs. 1 and 2, for the supply of the crushed ores D ; figs. 1 and 2 represent a metal trough, to form a bath, into which the ores are precipitated, to render them suitable for extraction of the metals.

Having now described my invention, I claim the fire-clay chambers as described in fig. 1, marked A A A A, provided with perforated crowns and suitable hoppers for the introduction of the ores to be treated.

In witness whereof I heroby set my hand, this twenty-seventh day of October, 1884.

J B.-GAFFORD.

Witness—

GEO. M. MARSH.

This is the specification referred to in the annexed Letters of Registration granted to John B.-Gafford, the 30th day of December, A.D., 1884.

AUGUSTUS LOFTUS.

REPORT.

Sir,

We do ourselves the honor to report, in reply to your blank cover, 1st instant, transmitting Mr. J. B.-Gafford's Petition for the registration of an invention entitled "The Improved Roasting Furnace," that we are of opinion the prayer of the Petitioner may be granted in terms of his specification, drawings, and claim.

The Under Secretary of Justice.

Sydney, 21 November, 1884.

We have, &c.,

E. C. CRACKNELL.
GOTHER K. MANN.

[Drawings—one sheet.]

Fig. 2.

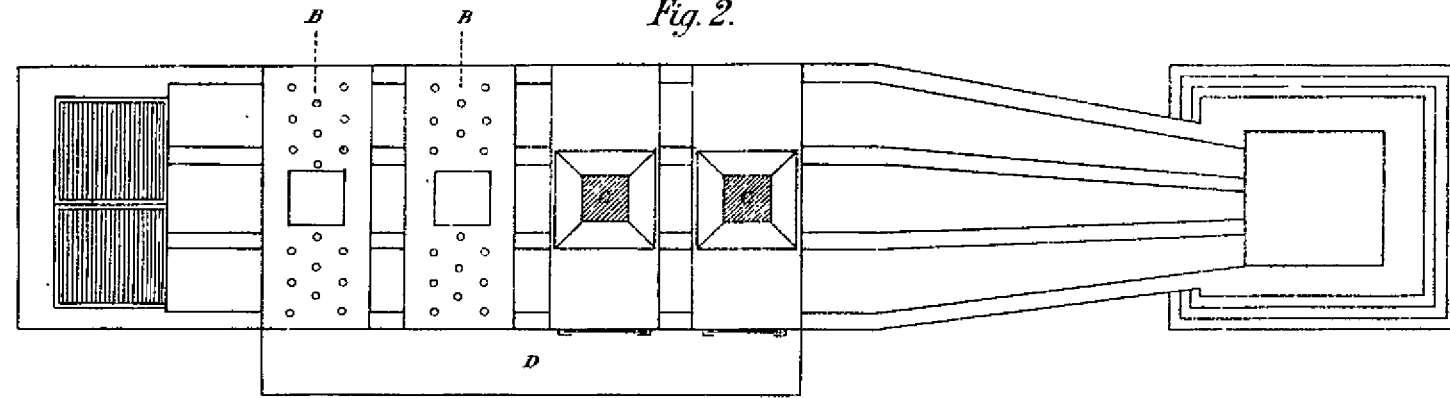
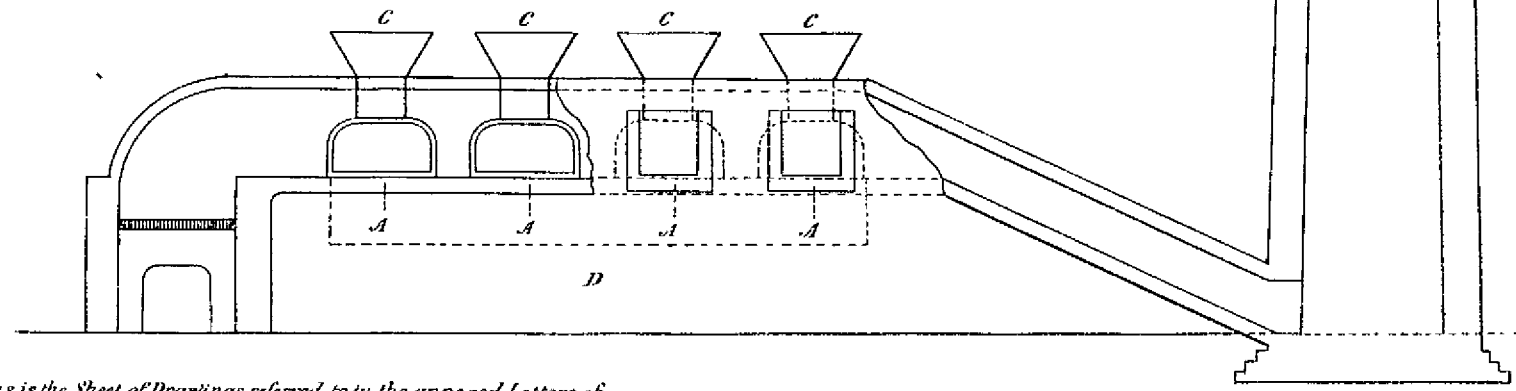
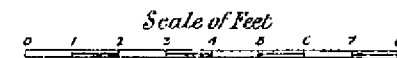


Fig. 1.



This is the Sheet of Drawings referred to in the annexed Letters of
 Registration, granted to John B. Gafford, the thirtieth day of
 December, A. D., 1884.

Augustus Lofius.



(Sig. 245~)



A.D. 1884, 30th December. No. 1556.

AN IMPROVED SCORING OR REGISTERING MACHINE,

LETTERS OF REGISTRATION to Thomas Clarke Jenkins, for an Improved Scoring or Registering Machine.

[Registered on the 31st day of December, 1884, in pursuance of the Act 16 Vic. No. 24.]

BY HIS EXCELLENCY THE RIGHT HONORABLE SIR AUGUSTUS WILLIAM FREDERICK SPENCER LOFTUS (commonly called LORD AUGUSTUS LOFTUS), Knight Grand Cross of the Most Honorable Order of the Bath, a Member of Her Majesty's Most Honorable Privy Council, Governor and Commander-in-Chief of the Colony of New South Wales and its Dependencies.

TO ALL TO WHOM THESE PRESENTS SHALL COME, greeting :

WHEREAS THOMAS CLARKE JENKINS, of Wellington, in the Colony of New Zealand, hath by his Petition humbly represented to me that he is the author or designer of a certain invention or improvement in manufactures, that is to say, of an invention entitled "An Improved Scoring or Registering Machine," which is more particularly described in the specification and the sheet of drawings which are hereunto annexed ; and that he, the said Petitioner, hath deposited with the Honorable the Treasurer of the said Colony of New South Wales the sum of Twenty Pounds sterling, for defraying the expense of granting these Letters of Registration, as required by the Act of Council, sixteenth Victoria, number twenty-four ; and hath humbly prayed that I would be pleased to grant Letters of Registration, whereby the exclusive enjoyment and advantage of the said invention or improvement might be secured to him for a period of fourteen years : And I, being willing to give encouragement to all inventions and improvements in the arts or manufactures which may be for the public good, and having received a report favourable to the prayer of the said Petition, from competent persons appointed by me to examine and consider the matters stated therein and to report thereon for my information, am pleased, with the advice of the Executive Council, and in exercise of the power and authority given to me by the said Act of Council, to grant, and do by these Letters of Registration grant unto the said Thomas Clarke Jenkins, his executors, administrators, and assigns, the exclusive enjoyment and advantage of the said invention or improvement, for and during the term of fourteen years from the date hereof ; to have, hold, and exercise unto the said Thomas Clarke Jenkins, his executors, administrators, and assigns, the exclusive enjoyment and advantage thereof, for and during and unto the full end and term of fourteen years from the date of these presents next and immediately ensuing, and fully to be complete and ended : Provided always, that if the said Thomas Clarke Jenkins shall not, within three days after the granting of these Letters of Registration, register the same in the proper office in the Supreme Court, at Sydney, in the said Colony of New South Wales, then these Letters of Registration, and all advantages whatsoever hereby granted, shall cease and become void.

In witness whereof, I have hereunto set my sign manual, and have caused the present Letters of Registration to be sealed with the seal of the said Colony of New South Wales, at Government House, Sydney, in New South Wales, this thirtieth day of December, in the year of our Lord one thousand eight hundred and eighty-four.

[L.S.]

AUGUSTUS LOFTUS.

An Improved Scoring or Registering Machine.

SPECIFICATION of THOMAS CLARKE JENKINS, of Wellington, in the Colony of New Zealand, for an invention entitled "An Improved Scoring or Registering Machine."

THIS invention has been designed for the purpose of providing a new and improved device for registering purposes, as, for instance, the scores in a game of cricket, where it is desired to register the individual score of each player, and, at the same time, to show above them a register of the total or aggregate sum of all the individual scores, which device is to be known as a multiplex register; and it consists of the special mechanism for actuating a number of sets of decagonal discs, on the outer surface of the rim of which numerals are arranged to register independently of each other; and it also consists in the mechanism for communicating motion to an additional set of discs placed above them, to register simultaneously with any of the lower sets, and show the total number registered on all of them. The whole are enclosed in a wooden case, provided with apertures in the front, opposite each set of discs, and through which the numbers on each respective set are seen. Each of the lower sets contains three discs, or may contain more, if necessary, on each of which numerals are arranged from 0 to 9 inclusive to register units, tens, and hundreds; and the top set for registering the total contains four discs, or may contain more, if necessary, numbered in the same manner, to register up to thousands.

The invention further consists in various parts and details and numerous combinations of the same, as will be fully described and set forth hereinafter.

Reference is to be had to the accompanying drawings forming part of this specification, in which similar letters of reference indicate corresponding parts in all the figures.

Fig. 1 is a front elevation of my improved multiplex register.

Fig. 2 is a plan of one set of discs looking down from the line BB (fig. 10), but on a larger scale, and with the outer rim, on which the numbers are written, removed.

Fig. 3 is a face view of the inner or left-hand side of each disc, excepting the disc on the extreme left of each set, which is simply provided with a plain plate without pins or catch.

Fig. 4 is a face view of the outer or right-hand side of each disc.

Fig. 5 is a cross-sectional view on the line XX, fig. 2, with parts broken away.

Fig. 6 is a face view of the outer or right-hand side of the plate H, fig. 2.

Fig. 7 is a cross-sectional view on the line YY, fig. 2, parts being broken away.

Fig. 8 is a face view of the outer or right-hand side of the plate G, fig. 2.

Fig. 9 is a back elevation, drawn to a larger scale, between the lines WW and W¹W¹, fig. 1; and

Fig. 10 is a cross-sectional elevation on the line W¹W¹, fig. 1, also drawn to a larger scale.

The case A is provided in its front with openings, numbered from 1 upwards to as many as there are sets of discs in the case. These openings are covered with glass, and behind each a set of discs is journaled on a shaft parallel with it, on each of which discs numerals are arranged from 0 to 9 inclusive. Above these openings a larger one is also formed in the case A, over which the word "total" is written, and behind which an additional set of discs is journaled in the same manner as the lower ones, which set is connected to each of the lower sets in such a manner, to be hereinafter described, that it will register simultaneously with any of them.

Each set of discs is firmly screwed to a frame C, figs. 9 and 10, in the interior of the case A, by means of wing pieces *c*. Attached to each end of their respective shafts, and underneath each of the lower sets, at its units or right-hand side, a shaft D is journaled in two bearings *dd*, terminating at its interior end in a crank D¹, and extending, at the other end, to the outside of the case A, where it is provided with a crank-handle D², by means of which the registering discs are actuated.

The manner in which the discs of each set are arranged to register, and the mechanism by which they are actuated, and actuate each other, is described as follows, viz. :—

Three (or more, if necessary) rollers or discs of wood EEE, on each of which an outer rim formed into ten flat equal faces is fixed, shown at fig. 10, and these discs are mounted loosely on a shaft *e*, shown by two dotted lines running through the centres of said rollers. Each roller is provided on its outer or right-hand face with a ten-tooth ratchet-wheel F, and on its inner or left-hand face with a circular plate *f*; these are screwed to the said rollers, as shown at figs. 3 and 4. On the plate *f* is pivoted a pawl *f*¹, which is provided at one end with a pin *f*², adapted to pass into the notches between the teeth of the ratchet-wheel F of the next disc to its left, and at the other end is provided with a spring *f*³, which presses against a pin *f*⁴ in the plate *f*, and keeps the pin *f*² in the other end of the pawl *f*¹ always pressed towards the ratchet-wheel. The plate *f* is also provided with a pin *f*⁵, which projects a short distance from its surface, and which, at a certain point in its revolution, presses the stop-catch G¹ on the plate G out from the ratchet-wheel of the next disc. Between the first and second and second and third discs a circular plate G, fig. 8, is fixed rigidly on the shaft *e*, by means of a screw which passes through a projection on its outer face, and into the shaft. The plate G is cut away at the top for the space of two notches of the ratchet-wheel F, as shown at fig. 8, and is slightly larger in diameter than the ratchet-wheel F, so that the pin *f*² of the pawl *f*¹ on the plate *f*, which travels on its periphery, will not engage the ratchet-wheel F excepting at that part of its revolution when it comes over the cut-away portion at the top. On the plate G is pivoted a stop-catch G¹, formed with a projecting flange G², and having a pin *g* at one end, which enters the notches in the ratchet-wheel F of the next disc to the left. The other end of the catch G¹ is provided with a spring *g*¹ of the form shown at fig. 8, which spring presses against the projection on the outer face of the plate G, and always keeps the pin *g* on the catch G¹ pressed into a notch on the ratchet-wheel of the next disc to the left. The plate G is provided with another catch *g*², pivoted like the catch G¹, but turned the opposite way, and having a pin *g*³ projecting over and into a notch on the ratchet-wheel F. The catch *g*² is provided with a spring at its opposite extremity, fitted in all respects like the spring *g*¹ on the catch G¹. The edge of the plate G has a small portion cut out under the pin of each catch, to allow the pins to drop into the notches of the ratchet-wheel.

To the right of the units disc, at a short distance from it, a plate H, fig. 6, is fixed firmly to the shaft *e*, in the same manner as the plate G. The plate H is similar to the plate G in every respect, but provided with slightly different catches, and need not necessarily be cut away at the top like the plate G. To the plate H is pivoted a catch *h*, having a pin *h*¹ at one end, adapted to pass into the notches between the teeth of the ratchet-wheel of the units disc, and at the other end is provided with a spring *h*², which presses

An Improved Scoring or Registering Machine.

presses at its extremity against a pin h^3 in the plate H, and always keeps the end in which the pin h^1 is fixed pressed towards the teeth of the ratchet-wheel of the units disc. The plate H is also provided with a catch i , similar in all respects to the catch g^2 on the plate G.

Between the plate H and the ratchet-wheel F of the units disc a lever K is loosely mounted on the shaft a , which lever is provided at its outer end with a pawl K¹, which is pressed against the teeth of the ratchet-wheel F of the units disc by a spring K². The upper edge of the lever K is formed with a horn-shaped projection K³, by means of which the pin h^1 on the catch h is pressed out from between the teeth of the ratchet-wheel F, when the crank-handle D² is in its position of rest.

To the right of the plate II a lever L, fig. 2, is loosely mounted on the shaft e and slotted or forked at its outer end to receive a connecting rod, by means of which its connection with the "total" set of discs is established. The lever L is rigidly fastened near its outer end to the lever K by means of a pin L¹, shown by the dotted lines at fig. 2, whose central part is thicker than the ends for a distance corresponding to a little more than the greatest thickness of the plate II, so that when the ends are riveted into the levers L and K respectively the said levers will work freely, but rigidly, together with the plate II between them. Between the levers L and K a piece of metal M is loosely mounted on the pin L¹, and provided with a slot in its lower end to receive a connecting-rod from the crank D¹.

Directly underneath the levers L and K of each of the lower sets of discs, and in a vertical line with the piece M, a crank shaft D is journaled in two bearings dd , screwed to the frame C. The shaft D is provided at its inner end with a crank D¹, and extends at the other end to the outside of the case A, where it is provided with a crank-handle D². The crank D¹ is provided with a pin D³, on which a piece of metal D⁴, slotted at its upper end, is loosely mounted. A connection M¹ is arranged between the crank D¹ and the levers L and K, formed of two pieces of metal m and m^1 . m is a flat piece of metal, pinned loosely at its upper end in the slot formed in the piece M, and bent at its lower in a right angle, into which the upper extremity of the piece m^1 is screwed, and fastened by a jamb nut m^2 . The lower end of the piece m^1 is flattened to fit the slot in the piece D⁴ on the crank D¹, where it is loosely pinned. The ring-piece d , nearest the crank of each set of discs, in which the crank-shaft D is journaled, is provided with a spring N, fastened to a flange or projection on its inner surface, which spring presses against a circular boss N¹ fixed to the shaft D. The boss N¹ is flattened on its edge in a line with the handle D² in the form of a ratchet-tooth, which the spring N presses into when the handle D² comes to the end of each revolution, and prevents the handle from being moved backwards.

The manner in which connection is made between the lower sets of discs and the "total" set is as follows, viz. :—

A transverse shaft O, running the full width of the frame C, is journaled loosely in bearings P, firmly screwed to the top of the frame C. The shaft O is provided, immediately over the levers L of each of the lower sets of discs, with a piece of metal P¹, rigidly fixed to it, which piece is cut away from the inner end, that is, the end where it is attached to the shaft O, to within a short distance of its outer extremity, forming three equal slots, in each of which a lever p works loosely on the shaft O, corresponding to the levers L, of the three rows of sets of discs immediately below, as shown at fig. 9. On the shaft O a lever R is also rigidly fixed directly under the piece M, between the levers L and R of the "total" set of discs, and is connected to the piece M of the "total" set by a connecting rod V, formed in the same manner as the connecting-rod M¹ between the pieces M of the lower sets of discs and the cranks.

The levers L of each of the lower sets of discs are connected to the levers p on the shaft O by means of connecting-rods S, the ends of which enter the slots or forks in the ends of the levers L and p respectively, and are there loosely pinned. The lever L of the "total" set of discs is provided with a spiral spring T, which extends to a catch at the top of the case, and which draws the mechanism back to its original position after each turn of the handle. A bell, not shown in drawing, is also connected with the shaft O by means of a lever, similar to R, which rings one stroke for each turn of the handle D².

The manner in which the aforesaid parts perform the object of this invention is as follows, viz. :—

The handle D² on the shaft D being turned through one-half of a revolution, the crank D¹ on the same shaft, by means of the connecting-rod M¹ draws the lever R, to which the pawl K¹ is pivoted, a sufficient distance to move the ratchet-wheel of the units disc the space of one tooth. As the lever K is moved the horn-shaped projection K³ at its top edge recedes from under the pin h^1 of the stop-catch h , which is pivoted on the plate H, and the catch h being pressed by the spring h^2 the pin h^1 engages the next notch in the ratchet-wheel and prevents the disc from moving more than one-tenth of a revolution, and as the handle D² completes its revolution the lever K returns to its original position, and in so doing the horn-shaped projection presses the pin h^1 of the catch h out from the notch in the ratchet-wheel, and the pawl K¹ engaging another tooth at the same time permits of the ratchet-wheel and the disc to which it is attached being moved another tenth of a revolution at the next turn of the handle. The catch i on the plate H is pivoted at such an angle to the direction of motion of the teeth of the ratchet-wheel F that the pin in its end is pressed out from between the teeth of the ratchet-wheel by the latter's own motion as it revolves, but keeps the disc from moving while the stop-catch h is pressed out from the ratchet F, as above described, and will not allow it to turn backwards.

When the units disc has made nine-tenths of a revolution the pin f^2 of the pawl f^1 on the plate f , attached to the inner side of the units disc, comes directly over the cut-away portion of the circular plate G, which is fixed to the shaft e , between the units and tens discs, and drops into a notch between the teeth of the ratchet-wheel of the tens disc; at the same time the pin f^3 on the plate f has come under the flange G², formed on the catch G¹ on the plate G, and forced the pin g in its end out from the ratchet-wheel of the tens disc, so that at the next movement of the units disc the pawl f^1 , by means of the pin f^2 , draws the ratchet-wheel of the tens disc one-tenth of a revolution, and the pin f^3 moving from under the catch G¹, at the same time, allows the pin g in its end to fall into the next notch, which, in so doing, stops the ratchet-wheel from moving more than one tooth, and, at the same time, rises at the other end and forces the pin f^2 out from the ratchet-wheel, so that it cannot again engage it until the units disc has made another nine-tenths of a revolution. The catch g^2 on the plate G serves the same purpose as the catch i on the plate H, which has been described.

The

An Improved Scoring or Registering Machine.

The hundreds disc is actuated by a similar plate *f* with the same pawl and pins as above described, fixed to the left side of the tens disc, and so on in like manner, no matter how many discs there may be in a set.

The simultaneous action of the "total" set of discs with any of the lower sets is effected by connecting-rods *S* from the levers *L* of each of the lower sets to the levers *p* on the shaft *O*, and by a connecting-rod *V* from the lever *R* on the shaft *O* to the piece *M*, between the levers *L* and *K* of the "total" set.

The piece *P*¹ on the shaft *O*, as before described, being solid at its outer extremity and rigidly fixed to the shaft *O*, it will be seen that when a handle belonging to any one of the lower sets of discs is turned the lever *L* of that set is drawn downwards, and that being connected to one of the levers *p* on the shaft *O* causes the lever *p*, to which it is connected, to move downwards also, and the lever *p* coming into contact with the solid extremity of the piece *P*¹ causes that, and also the shaft *O*, to which it is attached, to move with it, and the lever *R*, being also rigidly fixed to the shaft *O*, is moved downwards with it, and by means of the connecting-rod *V* between it and the "total" set of discs causes the latter to register in the same manner and at the same moment as the lower one.

It will further be seen, from the arrangement of the levers on the shaft *O* and the aforesaid connections, that any one of the handles may be turned and registration will be effected simultaneously on the lower set of discs to which the handle belongs and the "total" set without in any way affecting the others until their respective handles are turned, and any one or more sets may, in fact, be broken without affecting the correct registration of the others. The lower handle at figs. 9 and 10 is shown turned half round, from which the action of the various connections may be clearly seen.

Having thus described the nature of my said invention, and the manner of performing the same, I would have it understood that what I claim is—

First—The combination of the following parts, viz. :—The levers *L* and *K*, the plates *H* and *G*, the plate *f*, ratchet *F*, pawls *K*¹ and *f*¹, and the catches *h*, *i*, *G*¹, *g*², arranged to actuate discs, carrying numbers in such a manner that each successive disc is revolved one-tenth of a revolution after the preceding one has made nine-tenths of a revolution, substantially as herein described and explained, and as illustrated in figs. 2 to 8 of the drawings.

Second—The combination with the foregoing of the crank-handle operating mechanism consisting of the handle *D*², the shaft *D*, crank *D*¹, piece *D*⁴, and connecting-rod *M* (arranged to take up wear), the boss *N*¹, and the spring *N*, by means of which the units disc of each of the lower sets is caused to revolve one-tenth of a revolution for each turn of the crank-handle *D*², substantially as herein described and explained, and as illustrated on the drawings.

Third—The combination with the first claim of the shaft *O* and its piece *P*¹, the levers *p*, the lever *R*, and the connecting-rods *S* and *V*, by the combined action of which the "total" set of discs is caused to register simultaneously with any of the lower sets, as herein described and explained, and as illustrated on the drawings.

In witness whereof, I, the said Thomas Clarke Jenkins, have hereto set my hand and seal, this twenty-seventh day of October, one thousand eight hundred and eighty-four.

THOMAS CLARKE JENKINS,
(By his Attorney, EDWD. WATERS).

Witness—

FRED. WALSH,

This is the specification referred to in the annexed Letters of Registration granted to Thomas Clarke Jenkins, the thirtieth day of December, A.D. 1884.

AUGUSTUS LOFTUS.

REPORT.

Sir,

Sydney, 20 November, 1884.

We have the honor to state that we have carefully investigated the accompanying application by Mr. Thomas Clarke Jenkins for Letters of Registration for an invention entitled "An Improved Scoring or Registering Machine," and have had some difficulty in arriving at a conclusion.

We think, however, that there is sufficient novelty in the general combination of the parts of this machine to justify us in recommending that Letters of Registration be granted.

We have, &c.,
ARCH. C. FRASER.
THOS. RICHARDS.

The Under Secretary of Justice.



A.D. 1884, 30th *December*. No. 1557.

A SELF-ACTING CINDER-SIFTING ASH CLOSET.

LETTERS OF REGISTRATION to William John M'Ilwraith, for an invention entitled "A Self-acting Cinder-sifting Ash Closet."

[Registered on the 31st day of December, 1884, in pursuance of the Act 16 Vic. No. 24.]

BY HIS EXCELLENCY THE RIGHT HONORABLE SIR AUGUSTUS WILLIAM FREDERICK SPENCER LOFTUS (commonly called LORD AUGUSTUS LOFTUS), Knight Grand Cross of the Most Honorable Order of the Bath, a Member of Her Majesty's Most Honorable Privy Council, Governor and Commander-in-Chief of the Colony of New South Wales and its Dependencies.

TO ALL TO WHOM THESE PRESENTS SHALL COME, greeting :

WHEREAS WILLIAM JOHN M'ILWRAITH, of Elizabeth-street, Ashfield, in the county of Cumberland, in the Colony of New South Wales, hath by his Petition humbly represented to me that he is the assignee and purchaser of a certain invention or improvement in manufactures, that is to say, of an invention entitled "A Self-acting Cinder-sifting Ash Closet," which is more particularly described in the specification and the sheet of drawings which are hereunto annexed ; and that he the said Petitioner hath deposited with the Honorable the Treasurer of the said Colony of New South Wales the sum of Twenty Pounds sterling, for defraying the expense of granting these Letters of Registration, as required by the Act of Council, sixteenth Victoria, number twenty-four ; and hath humbly prayed that I would be pleased to grant Letters of Registration, whereby the exclusive enjoyment and advantage of the said invention or improvement might be secured to him for a period of fourteen years : And I, being willing to give encouragement to all inventions and improvements in the arts or manufactures which may be for the public good, and having received a report favourable to the prayer of the said Petition, from competent persons appointed by me to examine and consider the matters stated therein and to report thereon for my information, am pleased, with the advice of the Executive Council, and in exercise of the power and authority given to me by the said Act of Council, to grant, and do by these Letters of Registration grant unto the said William John M'Ilwraith, his executors, administrators, and assigns, the exclusive enjoyment and advantage of the said invention or improvement, for and during the term of fourteen years from the date hereof ; to have, hold, and exercise unto the said William John M'Ilwraith, his executors, administrators, and assigns, the exclusive enjoyment and advantage thereof, for and during and unto the full end and term of fourteen years from the date of these presents next and immediately ensuing, and fully to be complete and ended : Provided always, that if the said William John M'Ilwraith shall not, within three days after the granting of these Letters of Registration, register the same in the proper office in the Supreme Court, at Sydney, in the said Colony of New South Wales, then these Letters of Registration, and all advantages whatsoever hereby granted, shall cease and become void.

In witness whereof, I have hereunto set my sign manual, and have caused the present Letters of Registration to be sealed with the seal of the said Colony of New South Wales, at Government House, Sydney, in New South Wales, this thirtieth day of December, in the year of our Lord one thousand eight hundred and eighty-four.

[L.S.]

AUGUSTUS LOFTUS.

A Self-acting Cinder-sifting Ash Closet.

SPECIFICATION of WILLIAM JOHN McILWRAITH, of Elizabeth-street, Ashfield, in the county of Cumberland, in the Colony of New South Wales, gentleman, the purchaser and assignee of an invention entitled "A Self-acting Cinder Ash Closet."

THIS invention, which is patented and known in New Zealand as "Green's patent cinder ash closet," was the invention of a Mr. W. C. Green, of Manchester, England, who some time ago sold his right and interest therein to Messrs. Herbert Matthews and Frederick William Thomas Grant, of Sydney, and was by them resold to me, the said William John McIlwraith.

The sifting cinder ash closet is intended to supersede the common form of closet now in use. It is a self-acting deodorizer. The seat is so arranged on a pivot at each side with the short ends of two iron levers to the front fixed under the seat at each side. The levers have an iron jointed on to each of them and attached to each side of a hopper which receives the ashes and cinders on a sloped screen sifting the ashes and cinders, casting the latter into a small box, which is so placed to receive them. Attached to the hopper is a spout which conducts the dry ashes on to the excreta each time the closet is used. There is a box on the top of the closet to receive ashes, with a sloping bottom, and opening so as to let the ashes fall on to the grating. Where a pit is not used a large galvanized pan is used, if preferred; this, with the cinder box, can be taken out as convenient, either in front, the side, or back. This form of closet, which is preferred to all others in New Zealand for the great reform it has wrought as a sanitary measure of vast importance, lessens the evils which are often traced to accumulated filth. That which is such a source of danger to all now is rendered quite harmless and inoffensive by the proper use of these ingeniously and well-constructed machines.

The advantages of these closets are twofold:—(1) That the soil can be used immediately as a fine manure, and that manure is rendered quite harmless and inoffensive to the least possible degree. (2) The dry ashes tend to diminish and reduce to powder what is of an opposite nature; and another advantage can be claimed, and that is, that it can be used in a sick-room. It is especially useful where there is no sewerage, and where there is not likely to be any for many years. The restoration to the soil of that which is now cast away is another of the advantages to be derived from this form of closet.

Your Petitioner therefore humbly prays that Letters of Registration may be granted to him in respect of the abovementioned invention.

And your Petitioner will ever pray, &c.

Dated at Sydney, the sixteenth day of August, in the year of our Lord one thousand eight hundred and eighty-four.

W. J. McILWRAITH.

Witness—

G. C. WARLTON, Solicitor, Sydney.

This is the specification referred to in the annexed Letters of Registration granted to William John McIlwraith, the thirtieth day of December, A.D. 1884.

AUGUSTUS LOFTUS.

REPORT.

Sir,

Sydney, 22 September, 1884.

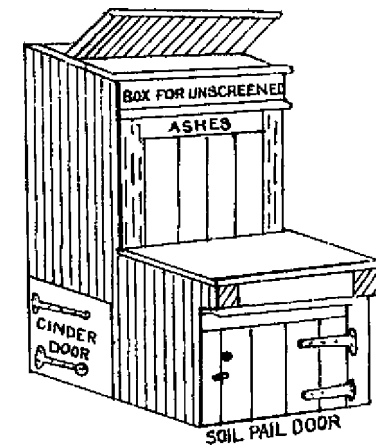
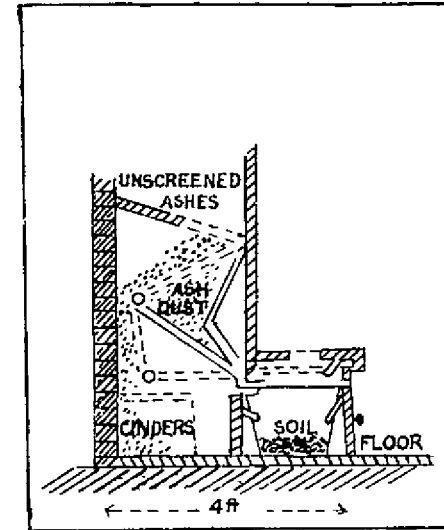
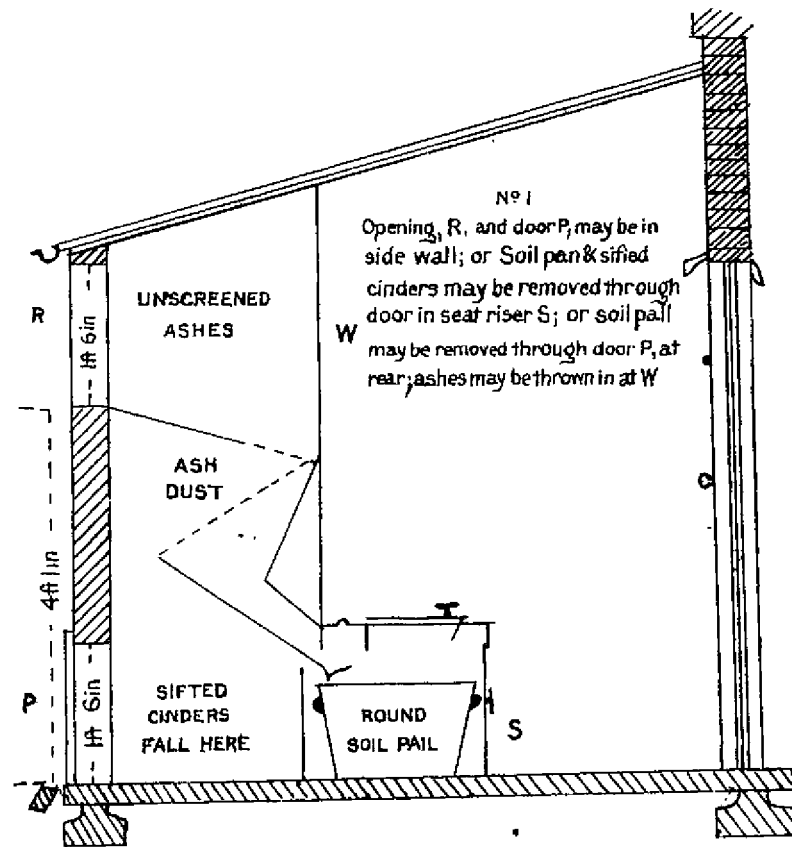
The application of William John McIlwraith for Letters of Registration for an invention entitled "A Self-acting Cinder-sifting Ash Closet" having been referred to us, we have to report that no Patent has been taken out in the Colony for such invention, but beg to point out that it is precisely the same in every respect as is shown in one of the volumes of the reports on the Royal Commissions on Improvement in Privies in England, for the last six or eight years in the Parliamentary Library; under such circumstances we consider it a legal question as to whether protection should be given or not.

We have, &c.,

JAMES BARNET.

WILLIAM C. BENNETT.

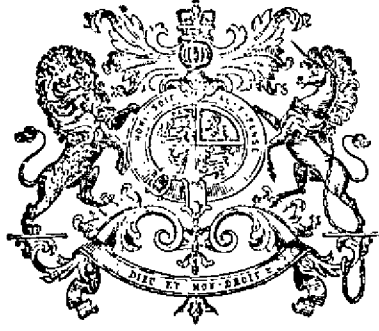
The Under Secretary of Justice.



*This is the Sheet of Drawings referred to in the annexed
Letters of Registration granted to William John
McTearnaith, the thirtieth day of December A.D. 1884.*

Augustus Loftus.

(sig 245-)



A.D. 1884, 30th December. No. 1558.

EXCELSIOR POTATO PLOUGH.

LETTERS OF REGISTRATION to George Taylor and Frederick Reid, for an invention entitled "Excelsior Potato Plough."

[Registered on the 31st day of December, 1884, in pursuance of the Act 16 Vic. No. 24.]

BY HIS EXCELLENCY THE RIGHT HONORABLE SIR AUGUSTUS WILLIAM FREDERICK SPENCER LOFTUS (commonly called LORD AUGUSTUS LOFTUS), Knight Grand Cross of the Most Honorable Order of the Bath, a Member of Her Majesty's Most Honorable Privy Council, Governor and Commander-in-Chief of the Colony of New South Wales and its Dependencies.

TO ALL TO WHOM THESE PRESENTS SHALL COME, greeting :

WHEREAS GEORGE TAYLOR and FREDERICK REID, of Granville, Sydney, New South Wales, have, by their Petition, humbly represented to me that they are the authors or designers of a certain invention or improvement in manufactures, that is to say, of an invention entitled "Excelsior Potato Plough," which is more particularly described in the specification, marked A, and the two sheets of drawings, marked B and C respectively, which are herunto annexed; and that they, the said Petitioners, have deposited with the Honorable the Treasurer of the said Colony of New South Wales the sum of Twenty Pounds sterling, for defraying the expense of granting these Letters of Registration, as required by the Act of Council, sixteenth Victoria, number twenty-four; and have humbly prayed that I would be pleased to grant Letters of Registration, whereby the exclusive enjoyment and advantage of the said invention or improvement might be secured to them for a period of fourteen years: And I, being willing to give encouragement to all inventions and improvements in the arts or manufactures which may be for the public good, and having received a report favourable to the prayer of the said Petition, from competent persons appointed by me to examine and consider the matters stated therein and to report thereon for my information, am pleased, with the advice of the Executive Council, and in exercise of the power and authority given to me by the said Act of Council, to grant, and do by these Letters of Registration grant unto the said George Taylor and Frederick Reid, their executors, administrators, and assigns, the exclusive enjoyment and advantage of the said invention or improvement, for and during the term of fourteen years from the date hereof; to have, hold, and exercise unto the said George Taylor and Frederick Reid, their executors, administrators, and assigns, the exclusive enjoyment and advantage thereof, for and during and unto the full end and term of fourteen years from the date of these presents next and immediately ensuing, and fully to be complete and ended: Provided always, that if the said George Taylor and Frederick Reid shall not, within three days after the granting of these Letters of Registration, register the same in the proper office in the Supreme Court, at Sydney, in the said Colony of New South Wales, then these Letters of Registration, and all advantages whatsoever hereby granted, shall cease and become void.

In witness whereof, I have herunto set my sign manual, and have caused the present Letters of Registration to be sealed with the seal of the said Colony of New South Wales, at Government House, Sydney, in New South Wales, this thirtieth day of December, in the year of our Lord one thousand eight hundred and eighty-four.

[L.S.]

AUGUSTUS LOFTUS.

Excelsior Potato Plough.

EXCELSIOR POTATO PLOUGH.

THE invention consists in the use of a grate fastened back of the share of the plough, this share being of a peculiar shape, and might be named gatherer.

The soil gathered by the share drops upon the grate behind it, which is shaken upwards and downwards by a quick motion; this motion is produced by cog-wheel and tappet cam.

The aim of the grate is to force the soil adhering to the potatoes to separate, and to leave the latter in the furrow of the plough, clean and ready to be bagged.

The motion of the grate is so arranged as to vary in its oscillations and rapidity of fall within the same time. These variations are necessary according to the nature and humidity of the soil.

The changes necessary to obtain these variations can be made by the ploughman himself.

Two horses and one man will be required to work the plough; and in accordance with our estimate can raise from $3\frac{1}{2}$ acres upwards per diem.

It is to be constructed of iron and steel.

TAYLOR & REID.

PORTIONS to be constructed of wrought-steel are:—Share, shaker, front part of the foot, spiral spring, axle, and belting chain.

The sole-plate and all the wheels excepting the travelling wheel are to be constructed of cast-steel. The travelling-wheel of cast-iron.

All the remaining portions to be made of wrought-iron.

TAYLOR & REID.

This is the specification marked "A" referred to in the annexed Letters of Registration granted to George Taylor and Frederick Reid, the 30th day of December, A.D. 1884.

AUGUSTUS LOFTUS.

REPORT.

Sir,

Sydney, 28 November, 1884.

In acknowledging the receipt of your B.C. communication, dated the 21st instant, covering a Petition from Messrs. Taylor & Reid for Letters of Registration for an invention entitled "The Excelsior Potato Plough," we have the honor to report that, having examined the plans and specification accompanying the above Petition, we are of opinion that the prayer thereof may be granted.

We have, &c.,

GOTHER K. MANN.
EDMUND FOSBERY.

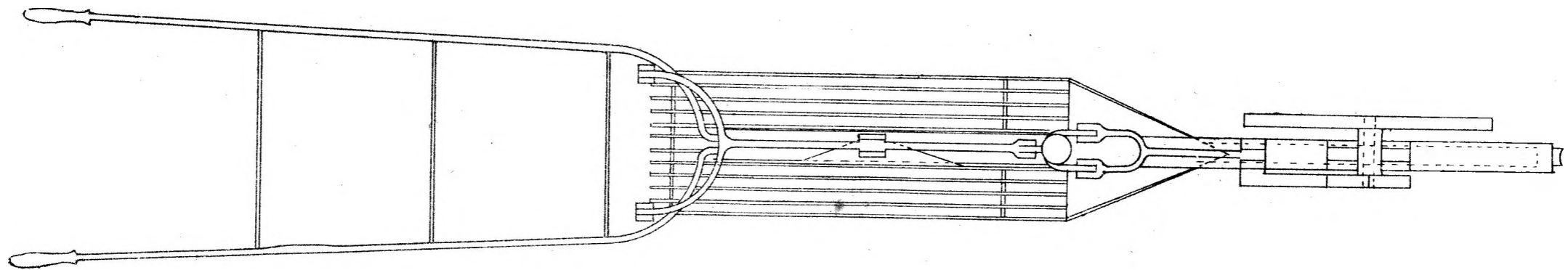
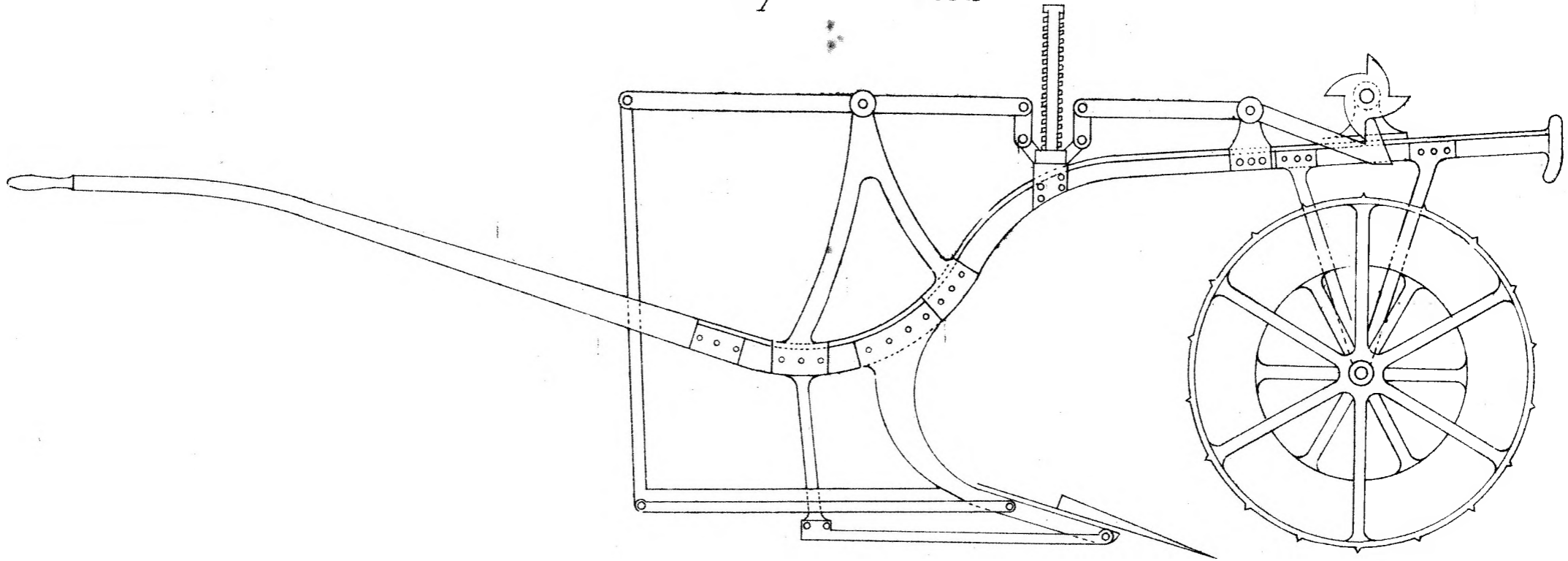
The Under Secretary of Justice.

[Drawings—two sheets.]

B

Excelsior Potato Plough
Taylor & Reid

1558



(Sig. 245-) *This is the Sheet of Drawings marked B referred to in the annexed Letters of Registration, granted to George Taylor, and Frederick Reid, the thirtieth day of December, A. D., 1884.*
Augustus Loftus.

PHOTO-LITHOGRAPHED AT THE GOVT. PRINTING OFFICE,
SYDNEY, NEW SOUTH WALES.



A.D. 1884, 30th *December*. No. 1559.

APPARATUS FOR VENTILATING RAILWAY CARRIAGES OR OTHER RAPIDLY-MOVING VEHICLES.

LETTERS OF REGISTRATION to Adam Miller, for improvements in Apparatus for Ventilating Railway Carriages or other rapidly-moving vehicles.

[Registered on the 31st day of December, 1884, in pursuance of the Act 16 Vic. No. 24.]

BY HIS EXCELLENCY THE RIGHT HONORABLE SIR AUGUSTUS WILLIAM FREDERICK SPENCER LOFTUS (commonly called LORD AUGUSTUS LOFTUS), Knight Grand Cross of the Most Honorable Order of the Bath, a Member of Her Majesty's Most Honorable Privy Council, Governor and Commander-in-Chief of the Colony of New South Wales and its Dependencies.

TO ALL TO WHOM THESE PRESENTS SHALL COME, greeting :

WHEREAS ADAM MILLER, of Lime-street, in the City of London, England, engineer, hath by his Petition humbly represented to me that he is the author or designer of a certain invention or improvement in manufactures, that is to say, of an invention entitled "Apparatus for Ventilating Railway Carriages or other rapidly-moving vehicles," which is more particularly described in the specification and the sheet of drawings which are hereunto annexed; and that he, the said Petitioner, hath deposited with the Honorable the Treasurer of the said Colony of New South Wales the sum of Twenty Pounds sterling, for defraying the expense of granting these Letters of Registration, as required by the Act of Council, sixteenth Victoria, number twenty-four; and hath humbly prayed that I would be pleased to grant Letters of Registration, whereby the exclusive enjoyment and advantage of the said invention or improvement might be secured to him for a period of fourteen years: And I, being willing to give encouragement to all inventions and improvements in the arts or manufactures which may be for the public good, and having received a report favourable to the prayer of the said Petition, from competent persons appointed by me to examine and consider the matters stated therein and to report thereon for my information, am pleased, with the advice of the Executive Council, and in exercise of the power and authority given to me by the said Act of Council, to grant, and do by these Letters of Registration grant unto the said Adam Miller, his executors, administrators, and assigns, the exclusive enjoyment and advantage of the said invention or improvement, for and during the term of fourteen years from the date hereof; to have, hold, and exercise unto the said Adam Miller, his executors, administrators, and assigns, the exclusive enjoyment and advantage thereof, for and during and unto the full end and term of fourteen years from the date of these presents next and immediately ensuing, and fully to be complete and ended: Provided always, that if the said Adam Miller shall not, within three days after the granting of these Letters of Registration, register the same in the proper office in the Supreme Court, at Sydney, in the said Colony of New South Wales, then these Letters of Registration, and all advantages whatsoever hereby granted, shall cease and become void.

In witness whereof, I have hereunto set my sign manual, and have caused the present Letters of Registration to be sealed with the seal of the said Colony of New South Wales, at Government House, Sydney, in New South Wales, this thirtieth day of December, in the year of our Lord one thousand eight hundred and eighty-four.

[L.s.]

AUGUSTUS LOFTUS.

Apparatus for Ventilating Railway Carriages.

SPECIFICATION of ADAM MILLER, of Lime-street, in the City of London, England, engineer, for an invention entitled "Apparatus for Ventilating Railway Carriages or other rapidly-moving vehicles."

My invention relates to means of withdrawing the hot foul air from railway carriages or other rapidly moving vehicles, utilising for that purpose the current of air caused by the motion of the vehicle, as I will describe, referring to the accompanying drawings. Fig. 1 is a longitudinal section, and fig. 2 a transverse section of a railway carriage having a single roof, with apparatus according to my invention applied thereto. Fig. 3 is a longitudinal section, and fig. 4 is a transverse section of a double-roofed railway carriage, in which the spaces between the roof and ceiling are utilised for carrying out my invention. Fig. 5 is a part longitudinal section of the ventilating channel and one of the openings into it, as I will now describe. Along the roof of the carriage I form a tube or channel, A, or several such channels, which may be put on outside the roof, as shown in figs. 1 and 2, or which may occupy the spaces between the roof and ceiling, as shown in figs. 3 and 4. I prefer to make these channels with trumpet or expanded mouths, as indicated at B. Through the ceiling of the carriage or its compartments I make apertures, C, into the channels A, each of these apertures having inclined cheeks, D, sloping down from it on each side of its upper mouth. The apertures may be provided with adjustable slides or valves. As the carriage passes rapidly through the air in either direction, there is a current along each of the channels A, and this current as it passes over the sloped mouth of the aperture C causes currents of air to rise through them, thus withdrawing the hot foul air next the ceiling of the carriage.

Having thus described the nature of my invention, and in what manner the same is to be performed, I claim—

For ventilating railway or other carriages, the construction in or along their roofs of longitudinal air channels, open at the ends, and communicating with the compartments by apertures through their ceiling, substantially as herein described.

In witness whereof, I, the said Adam Miller, have hereunto set my hand and seal, this twenty-fifth day of September, in the year of our Lord one thousand eight hundred and eighty-four.

ADAM MILLER.

Witness—

JNO. P. M. MILLARD.

This is the specification referred to in the annexed Letters of Registration granted to Adam Miller, the thirtieth day of December, A.D. 1884.

AUGUSTUS LOFTUS.

REPORT.

Sir,

Referring to your B.C. of the 3rd instant, forwarding a Petition from Mr. Adam Miller for Letters of Registration for an invention entitled "Apparatus for Ventilating Railway Carriages or other rapidly-moving vehicles," we have the honor to state that, having examined the drawings and specification accompanying the Petition, we are of opinion that Letters of Registration should be issued to the Petitioner in terms of the prayer of the Petition.

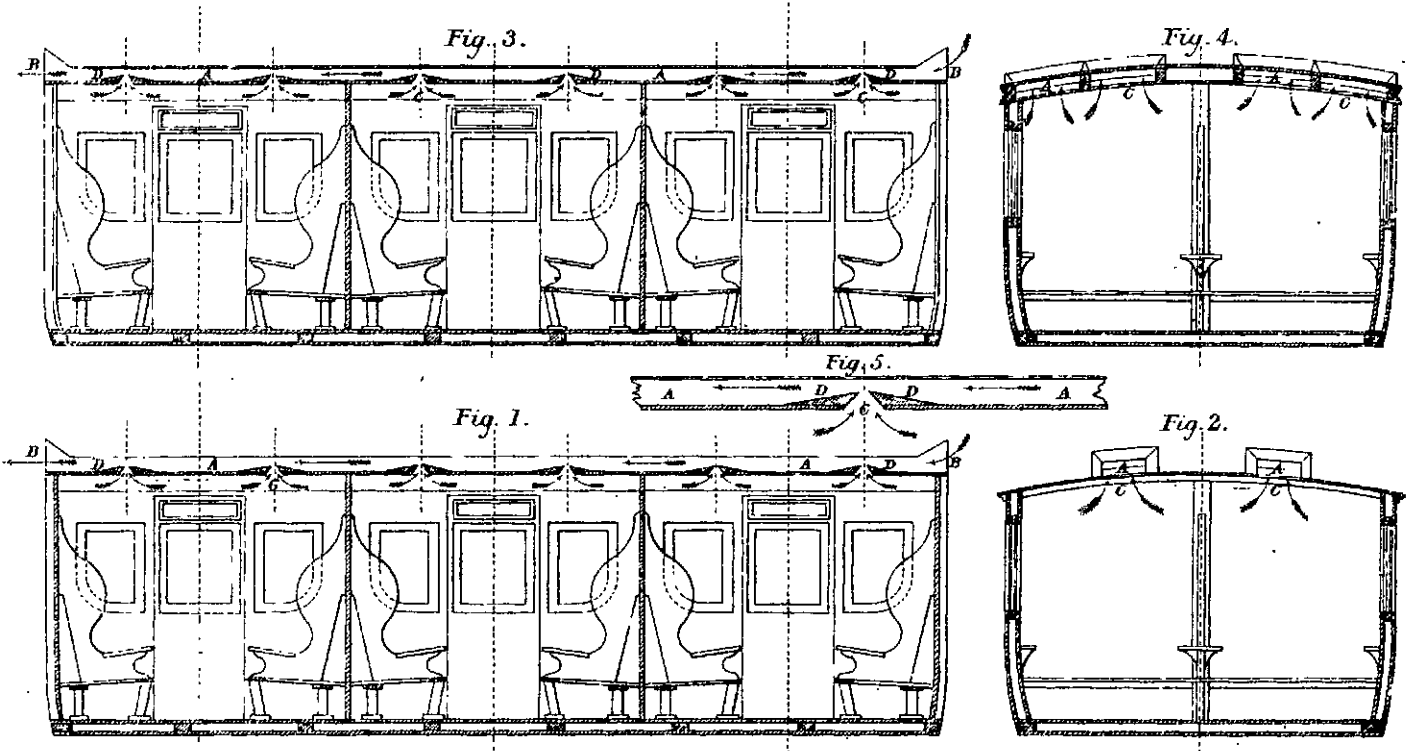
We have, &c.,

JOHN WHITTON.

E. O. MORIARTY.

The Under Secretary of Justice.

[Drawings—one sheet.]



*This is the Sheet of Drawings, referred to in the annexed
 Letters of Registration granted to Adam Miller, the thirtieth
 day of December A. D., 1884. Augustus Loftus.*

(Sig. 245~)



A.D. 1884, 30th December. No. 1560.

A DRILLING, DROPPING, AND PLANTING PLOUGH COMBINED.

LETTERS OF REGISTRATION to George Parkins, for a Drilling, Dropping, and Planting Plough combined.

[Registered on the 31st day of December, 1884, in pursuance of Act 16 Vic. No. 24.]

BY HIS EXCELLENCY THE RIGHT HONORABLE SIR AUGUSTUS WILLIAM FREDERICK SPENCER LOFTUS (commonly called LORD AUGUSTUS LOFTUS), Knight Grand Cross of the Most Honorable Order of the Bath, a Member of Her Majesty's Most Honorable Privy Council, Governor and Commander-in-Chief of the Colony of New South Wales and its Dependencies.

TO ALL TO WHOM THESE PRESENTS SHALL COME, greeting :

WHEREAS GEORGE PARKINS, of Frederickton, Macleay River, in the Colony of New South Wales, wheelwright and blacksmith, hath by his Petition humbly represented to me that he is the author or designer of a certain invention or improvement in manufactures, that is to say, of an invention entitled "A Drilling, Dropping, and Planting Plough combined," which is more particularly described in the amended specification and the sheet of drawings which are herewith annexed ; and that he, the said Petitioner, hath deposited with the Honorable the Treasurer of the said Colony of New South Wales the sum of Twenty Pounds sterling, for defraying the expense of granting these Letters of Registration, as required by the Act of Council, sixteenth Victoria, number twenty-four ; and hath humbly prayed that I would be pleased to grant Letters of Registration, whereby the exclusive enjoyment and advantage of the said invention or improvement might be secured to him for a period of fourteen years : And I, being willing to give encouragement to all inventions and improvements in the arts or manufactures which may be for the public good, and having received a report favourable to the prayer of the said Petition, from competent persons appointed by me to examine and consider the matters stated therein and to report thereon for my information, am pleased, with the advice of the Executive Council, and in exercise of the power and authority given to me by the said Act of Council, to grant, and do by these Letters of Registration grant unto the said George Parkins, his executors, administrators, and assigns, the exclusive enjoyment and advantage of the said invention or improvement, for and during the term of fourteen years from the date hereof ; to have, hold, and exercise unto the said George Parkins, his executors, administrators, and assigns, the exclusive enjoyment and advantage thereof, for and during and unto the full end and term of fourteen years from the date of these presents next and immediately ensuing, and fully to be complete and ended : Provided always, that if the said George Parkins shall not, within three days after the granting of these Letters of Registration, register the same in the proper office in the Supreme Court, at Sydney, in the said Colony of New South Wales, then these Letters of Registration, and all advantages whatsoever hereby granted, shall cease and become void.

In witness whereof, I have herewith set my sign manual, and have caused the present Letters of Registration to be sealed with the seal of the said Colony of New South Wales, at Government House, Sydney, in New South Wales, this thirtieth day of December, in the year of our Lord one thousand eight hundred and eighty-four.

[L.S.]

AUGUSTUS LOFTUS.

A Drilling, Dropping, and Planting Plough combined.

SPECIFICATION.

DESCRIPTION of plough (as per plan annexed).—A the plough; B the shear; C one of the mould-boards; D the seed-box; E the driving wheel, to drop seed; F the shears, to cover seed; G lever, to lift planter while going round the ends or from field to field; H hopper, where seeds fall.

Description of planter (as per plan annexed).—A the crank shafts; B the seed slide; C the connecting bolt; D the seed box; E the driving wheel; F the shears to cover the seed; G the lever; H the seed hoppers; J bottom of seed-box; K outside bottom of seed-box.

The plough is made of wrought iron, and both the planter and the plough are portable, so that the plough can be used without the planter.

The plough is worked by one man and a pair of horses for drilling, dropping, and planting maize and pumpkins, and the plough can be used without the planter for the purpose of middling corn and drilling potatoes and sweet turnips. It will also drop and cover, as required, from four to seven grains at 3 feet apart, and pumpkins, from one up to three grains, 6 feet apart.

The difference between this and the old plough is, that the old plough requires one man and two horses to drill the land first, and then two extra men to drop the seed, and three extra men to cover it; whereas the present implement saves the labour of six men in all in dropping and covering alone, and at the same time it does double the quantity of work in the same space of time with one man and two horses as the old implement did with six men, two horses, and two ploughs.

The explanation of the double amount of work is, that the old plough has to run through the same furrow or drill three times, namely, once to open one side, and then *vice versá*, and once up the centre to remove the weeds, &c.; whereas the present implement only traverses the furrow or drill once, because the mould-boards, marked C, when opened out, perform this work equally on both sides and in the centre, and in one trip only, and one man and two horses do this, in lieu of two horses and six men, as by the old plough.

The novelty of the invention is therefore distinctly as follows:—

That there is no other plough made or working on the same principle within the district or elsewhere to the applicant's knowledge and belief, and it accomplishes the work of six men and two horses with one man and two horses in half the time as by the old implement, as explained above. And therefore the applicant, as stated in the Petition, claims the novelty of the invention, and is desirous of having Letters of Registration granted to him, in accordance with the Act set forth and mentioned in the Petition made and signed in this matter.

This is the amended specification referred to in the annexed Letters of Registration granted to George Parkins, the 30th day of December, A.D. 1884.

AUGUSTUS LOFTUS.

REPORTS.

Sir,

In reply to your blank cover, 16th instant, we do ourselves the honor to state that as Mr. George Parkins' specification of "Drilling, Dropping, and Planting Plough," does not set forth the novelty of his invention, and, moreover, does not conclude with any distinct claim for registration; we are of opinion that it is necessary his application should be returned to him for rectification.

We have, &c.,

GOTHER K. MANN.
EDMUND FOSBERY.

The Under Secretary of Justice.

Sir,

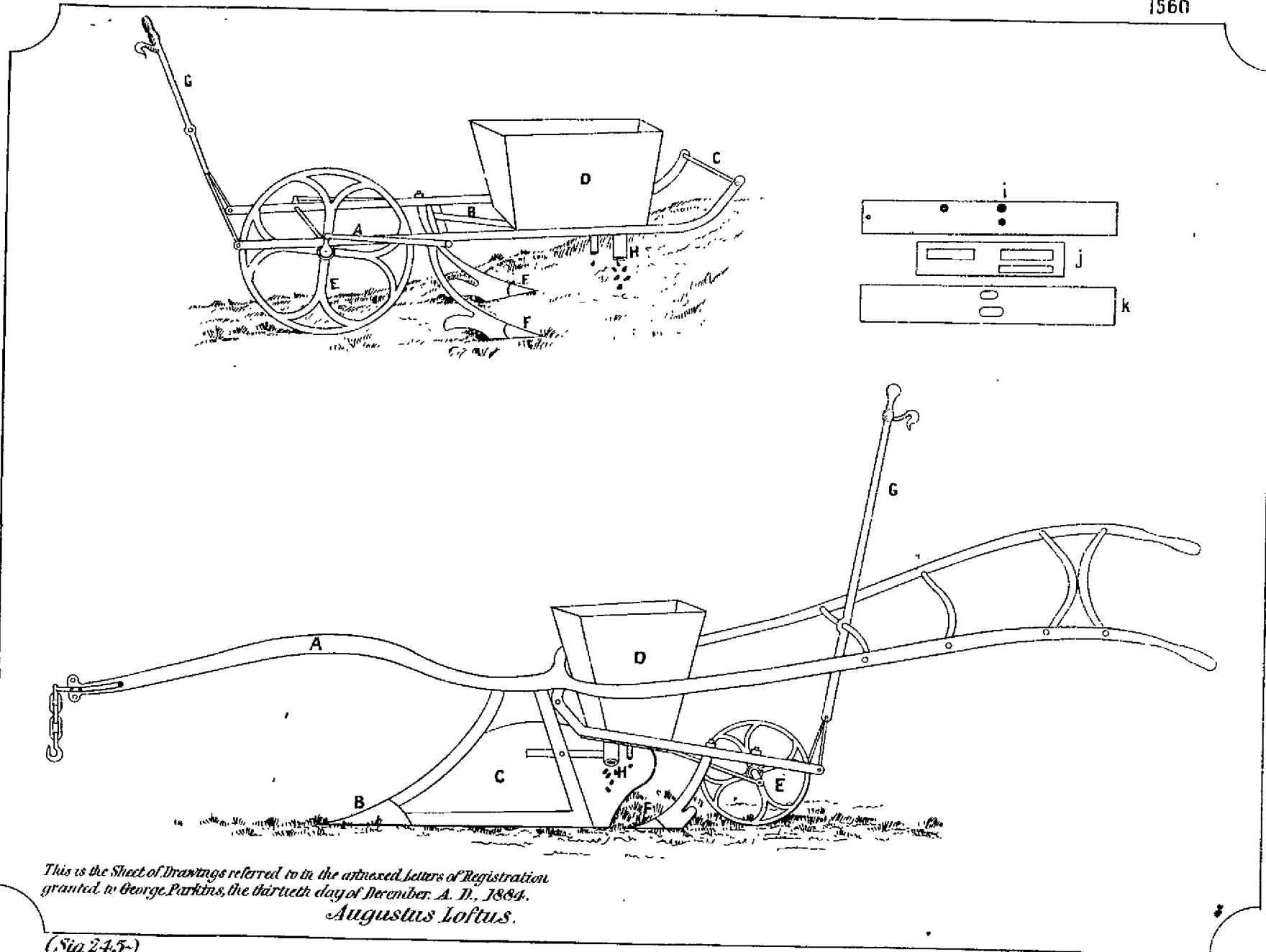
In acknowledging the receipt of your letter, dated the 22nd instant, covering amended specification for an invention by Mr. G. Parkins, entitled "A Drilling, Dropping, and Planting Plough," we do ourselves the honor to report that we are of opinion that the prayer of the Petitioner may now be granted.

We have, &c.,

GOTHER K. MANN.
EDMUND FOSBERY.

The Under Secretary of Justice.

[Drawings—one sheet.]



This is the Sheet of Drawings referred to in the annexed Letters of Registration granted to George Parkins, the thirtieth day of December, A. D. 1864.

Augustus Loftus.

(Sig. 24.5-)

Handwritten notes at the top of the page, including the word "SOL" and other illegible characters.

Handwritten signature or initials in the bottom right corner.